



**44" Mower**

**Groundsmaster® 120 Attachment**

Model No. 30546—21000001 and Up

**Operator's Manual**

# Contents

	Page
Introduction .....	2
Slope Chart .....	3
Safety and Instruction Decals .....	5
Assembly .....	6
Loose Parts .....	6
Installing the Castor Wheels .....	6
Installing the Carrier Frame and Deck to the Traction Unit .....	7
Installing the Drive Belt .....	7
Installing the Cutting Deck .....	8
Operation .....	8
Operating the Power Take Off (PTO) .....	8
Implement Lift Lever .....	8
Side Discharge or Mulch Grass .....	9
Adjusting the Height-of-Cut .....	9
Tips for Mowing Grass .....	9
Maintenance .....	11
Recommended Maintenance Schedule .....	11
Cutting Blade Service .....	11
Correcting Cutting Unit Mismatch .....	13
Setting the Front-to-Rear Pitch .....	13
Setting the Side-to-Side Leveling .....	14
Greasing the Bearings and Bushings .....	15
Servicing the Gearbox .....	15
Replacing the Deck Belt .....	16
Replacing the Drive Belt .....	17
Adjusting the Deck Idler Pulley Tension .....	17
Replacing the Castor Wheel Fork Bushings .....	18
Servicing the Castor Wheels and Bearings .....	19
Replacing the Grass Deflector .....	19
Storage .....	20
Troubleshooting .....	20

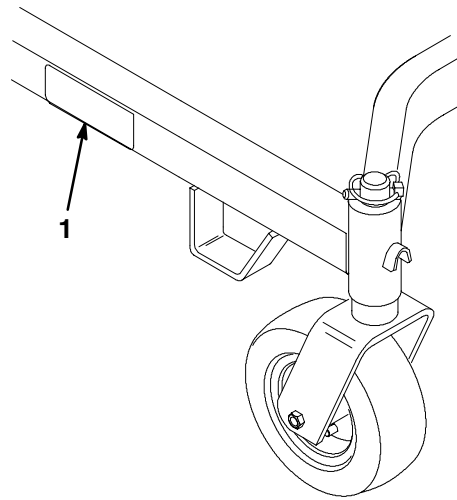

m-2571

**Figure 1**

1. Location of the model and serial numbers

Write the product model and serial numbers in the space below:

<b>Model No.</b> _____
<b>Serial No.</b> _____

This manual identifies potential hazards and has special safety messages that help you and others avoid personal injury and even death. **Danger, Warning, and Caution** are signal words used to identify the level of hazard. However, regardless of the hazard, be extremely careful.

**Danger** signals an extreme hazard that *will* cause serious injury or death if you do not follow the recommended precautions.

**Warning** signals a hazard that *may* cause serious injury or death if you do not follow the recommended precautions.

**Caution** signals a hazard that may cause minor or moderate injury if you do not follow the recommended precautions.

This manual uses two other words to highlight information. **Important** calls attention to special mechanical information and **Note:** emphasizes general information worthy of special attention.

## Introduction

Read this manual carefully to learn how to operate and maintain your product properly. The information in this manual can help you and others avoid injury and product damage. Although Toro designs and produces safe products, you are responsible for operating the product properly and safely.

Whenever you need service, genuine Toro parts, or additional information, contact an Authorized Service Dealer or Toro Customer Service and have the model and serial numbers of your product ready. Figure 1 illustrates the location of the model and serial numbers on the product.

# Slope Chart

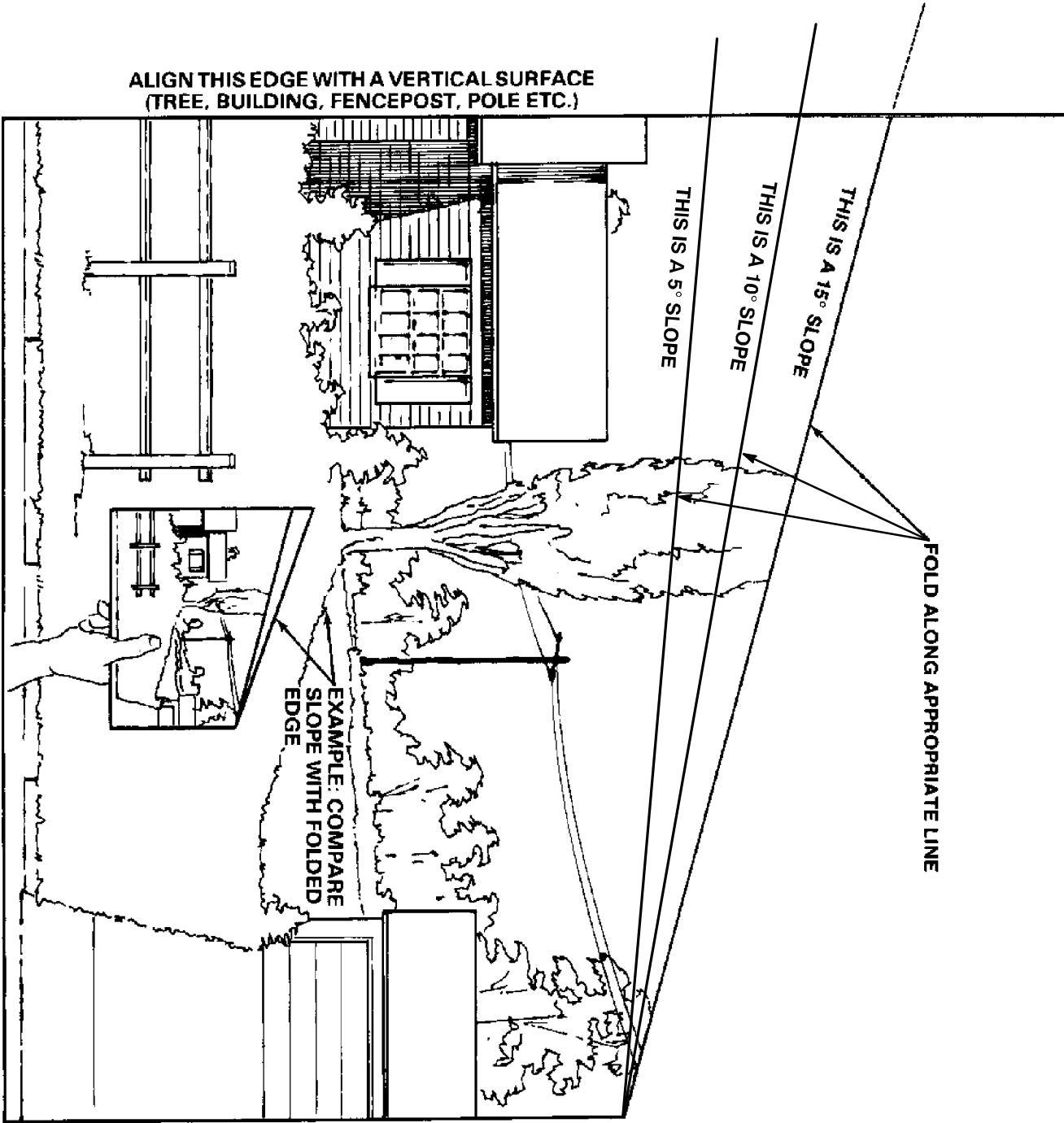



# Safety and Instruction Decals



Safety decals and instructions are easily visible to the operator and are located near any area of potential danger. Replace any decal that is damaged or lost.

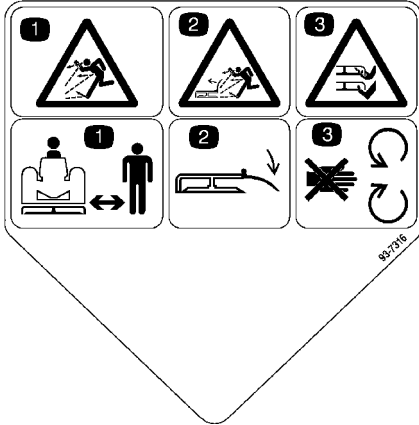

**Part No. 93-7316**

- |  |   |
|--|---|
| <ol style="list-style-type: none"> <li>1. Thrown object hazard—keep bystanders away.</li> <li>2. Thrown object hazard—keep grass deflector in place</li> </ol> | <ol style="list-style-type: none"> <li>3. Cutting/dismemberment hazard of hands or feet—stay away from rotating blades and moving parts.</li> </ol> |
|--|---|

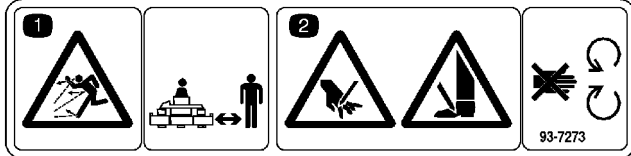

**Part No. 93-7273**

- |   |   |
|---|---|
| <ol style="list-style-type: none"> <li>1. Thrown object hazard—keep bystanders away.</li> </ol> | <ol style="list-style-type: none"> <li>2. Cutting/dismemberment hazard of hands or feet—stay away from rotating blades and moving parts.</li> </ol> |
|---|---|



**Part No. 93-7824**

- |  |   |
|--|---|
| <ol style="list-style-type: none"> <li>1. Thrown object hazard—keep bystanders away.</li> <li>2. Thrown object hazard—keep grass deflector in place</li> </ol> | <ol style="list-style-type: none"> <li>3. Cutting/dismemberment hazard of hands or feet—stay away from rotating blades and moving parts.</li> </ol> |
|--|---|

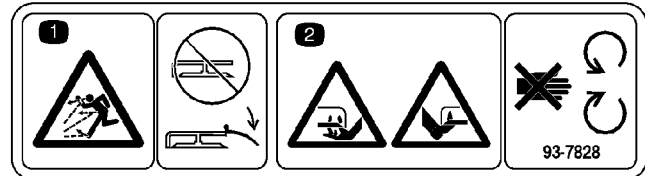

**Part No. 93-7828**

- |   |   |
|---|---|
| <ol style="list-style-type: none"> <li>1. Thrown object hazard—keep grass deflector in place</li> </ol> | <ol style="list-style-type: none"> <li>2. Cutting/dismemberment hazard of hands or feet—stay away from rotating blades and moving parts.</li> </ol> |
|---|---|

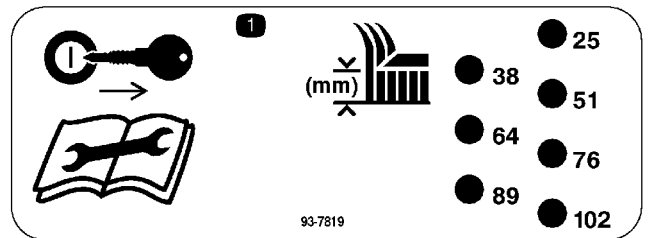

**Part No. 93-7819**

1. Remove key before changing height-of-cut or performing maintenance.

# Assembly

**Note:** Determine the left and right sides of the machine from the normal operating position.

## Loose Parts

**Note:** Use the chart below to identify parts used for assembly.

DESCRIPTION	QTY.	USE
Castor Wheel Assembly	2	Install castor wheels to carrier frame
Thrust Washer	8	
Linchpin	2	
Cap Screw, 3/8 in. x 1-3/4 in. (44 mm)	4	Install carrier frame to traction unit
Locknut, 3/8 in.	4	
Shim	2	
Flange Bolt, 3/8 in. x 7/8 in. (22 mm)	4	
Flat Washer	4	
Drive Belt	1	Mount to cutting unit and traction unit
Operator's Manual	1	Read before operating
Parts Catalog	1	Ordering parts

## Installing the Castor Wheels

1. Place two thrust washers onto the castor wheel forks (Fig. 2).
2. Insert the castor wheel forks into the carrier frame mounting tubes (Fig. 2).
3. Install two thrust washers onto the castor wheel forks, then secure with linchpins (Fig. 2).

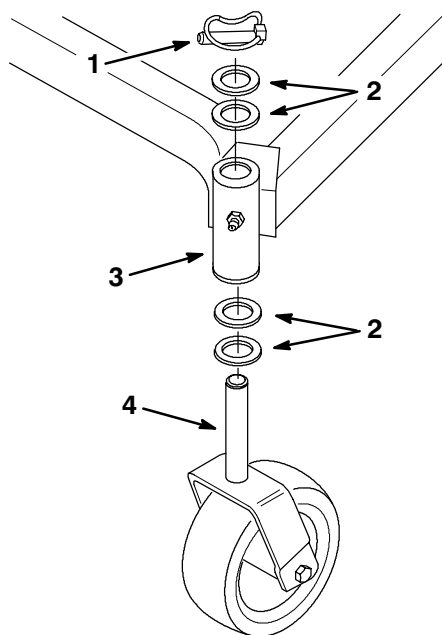
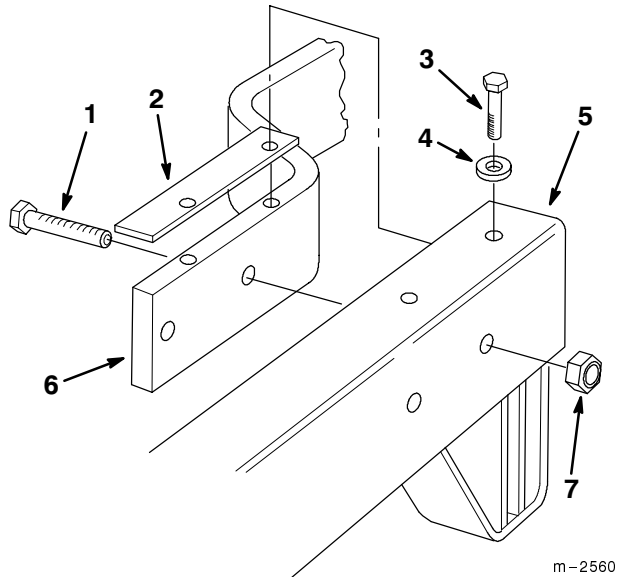

**Figure 2**

- |                  |                                |
|------------------|--------------------------------|
| 1. Linchpin      | 3. Carrier Frame Mounting Tube |
| 2. Thrust Washer | 4. Castor Wheel Fork           |

# Installing the Carrier Frame and Deck to the Traction Unit

1. Attach the carrier frame to the traction unit frame with the 4 (3/8 in. x 1-3/4 in. (44 mm)) cap screws and locknuts. Note that the locknuts must be on the outside of the carrier frame. Leave the locknuts loose to allow movement between the carrier and traction unit frames (Fig. 3).
2. Install the shims between the carrier frame and traction unit frame. Align the holes in the shims with the top holes in the traction unit and carrier frames (Fig. 3).
3. Install the 4 (3/8 in. x 7/8 in. (22 mm)) flange bolts with flat washers through the carrier frame and shims, and into the threaded holes in the top of the traction unit frame. Torque the flange bolts to 27-33 ft.-lb (37-45 N•m) (Fig. 3).
4. Torque the 4 (3/8 in. x 1-3/4 in. (44 mm)) cap screws and locknuts to 27-33 ft.-lb. (37-45 N•m) (Fig. 3).

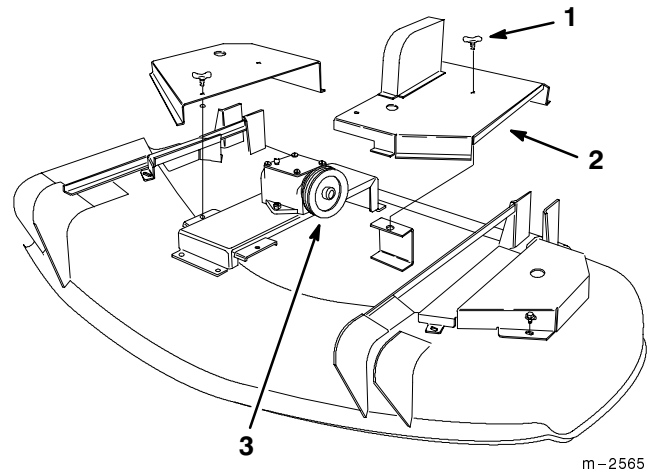

**Figure 3**

- |  |                        |
|--|------------------------|
| 1. 3/8 in. x 1-3/4 in. (44 mm) Cap Screw | 4. Flat Washer         |
| 2. Shim                                  | 5. Carrier Frame       |
| 3. 3/8 in. x 7/8 in. (22 mm) Flange Bolt | 6. Traction Unit Frame |
|  | 7. 3/8 in. Locknut     |

# Installing the Drive Belt

1. Rotate the two wing head studs on the left center deck cover 1/4 turn counterclockwise. Remove the left center deck cover to expose the gearbox input pulley (Fig. 4).



**Figure 4**

- |                             |                         |
|-----------------------------|-------------------------|
| 1. Wing Head Stud (typical) | 3. Gearbox Input Pulley |
| 2. Left Center Deck Cover   |                         |

2. Lift the idler pulley and install the drive belt onto the traction unit output pulley and gearbox input pulley (Fig. 5).
3. Release the idler pulley to allow the pulley to spring back on top of the drive belt (Fig. 5).

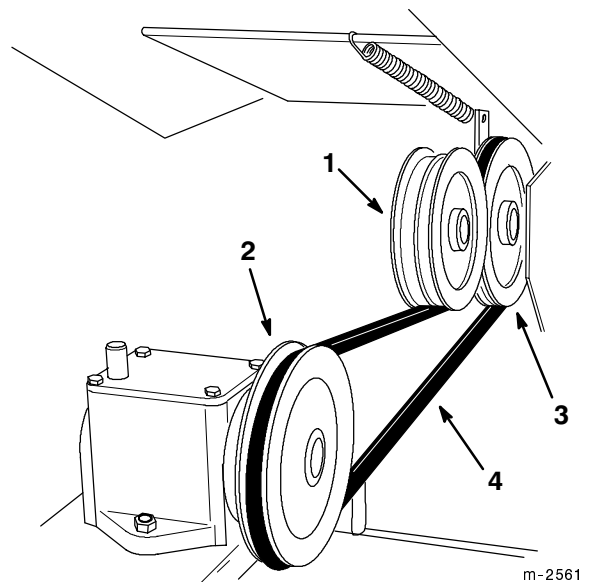

**Figure 5**

- |                         |                                |
|-------------------------|--------------------------------|
| 1. Idler Pulley         | 3. Traction Unit Output Pulley |
| 2. Gearbox Input Pulley | 4. Drive Belt                  |

4. Reinstall the left center deck cover onto the deck, then rotate the two wing head studs 1/4 turn clockwise to secure the cover to the deck (Fig. 4 on page 7).
5. Check the front-to-rear blade pitch. Refer to Setting the Front-to-Rear Pitch in the Maintenance section.

## Installing the Cutting Deck

1. Position the cutting deck under the carrier frame.
2. Mount the cutting deck to the carrier frame with four (4) clevis pins and hairpin cotters (Fig. 6).

**Note:** All four pins must be in the same hole locations to prevent uneven cutting.

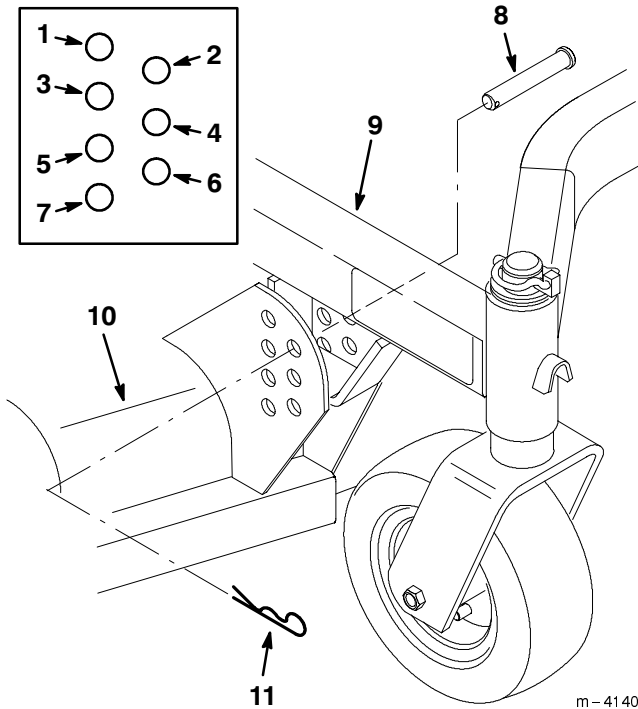

**Figure 6**

- |                                |                                |
|--------------------------------|--------------------------------|
| 1. 1in. (25 mm) Cut Height     | 6. 3-1/2in. (89 mm) Cut Height |
| 2. 1-1/2in. (38 mm) Cut Height | 7. 4in. (102 mm) Cut Height    |
| 3. 2in. (51 mm) Cut Height     | 8. Clevis Pin                  |
| 4. 2-1/2in. (64 mm) Cut Height | 9. Carrier Frame               |
| 5. 3in. (76 mm) Cut Height     | 10. Cutting Deck               |
|                                | 11. Hairpin Cotter             |

## Operation

**Note:** Determine the left and right sides of the machine from the normal operating position.

### Operating the Power Take Off (PTO)

The power take off (PTO) switch engages and disengages power to the electric clutch.

### Engaging the PTO

1. Release the parking brake.
2. Release pressure on the traction pedal to stop movement.
3. To engage lift cover and move the PTO switch to the “ON” position (Fig. 7).

### Disengaging the PTO

1. Closing the cover moves the PTO switch to the “OFF” position (Fig. 7).

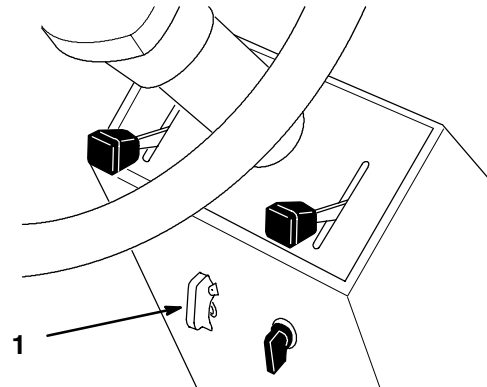

**Figure 7**

1. PTO switch

## Implement Lift Lever

The implement lift lever (Fig. 8) is used to raise and lower various attachments.

### Raising Attachments

1. Remove pressure from traction pedal to stop the machine.
2. Pull implement lift lever (Fig. 8) rearward to raise attachment to the desired height.

### Lowering Attachments

1. Remove pressure from traction pedal to stop the machine.
2. Push implement lift lever (Fig. 8) forward to lower attachment.

**Note:** Hold lift lever in down position 1-2 seconds after attachment in down to extend lift cylinder allowing attachment to float with changes in ground contour.

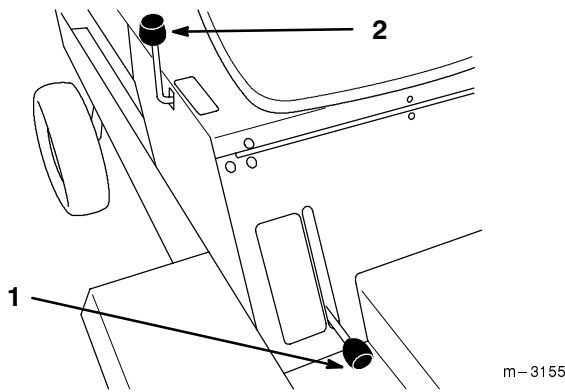

**Figure 8**

1. Parking brake                      2. Implement lift lever

## Side Discharge or Mulch Grass

The mower has a hinged grass deflector that disperses clippings to the side and down toward the turf.

!      **Danger**      !

**Without the grass deflector, discharge cover, or complete grass catcher assembly mounted in place, you and others are exposed to blade contact and thrown debris. Contact with rotating mower blade(s) and thrown debris will cause injury or death.**

- **Never remove the grass deflector from the mower because the grass deflector routes material down toward the turf. If the grass deflector is ever damaged, replace it immediately.**
- **Never put your hands or feet under the mower.**
- **Never try to clear discharge area or mower blades unless you move the power take off (PTO) to “OFF” and rotate the ignition key to “OFF.” Also remove the key and pull the wire off the spark plug(s).**

## Adjusting the Height-of-Cut

The height-of-cut is adjustable from 1 in. to 4 in. (25 to 102 mm) in 1/2-inch (13 mm) increments by relocating the clevis pins in different hole locations in brackets at each corner of the cutting unit (Fig. 9).

Stop the engine before adjusting the height-of-cut.

**Note:** All four pins must be in the same hole location for even cutting.

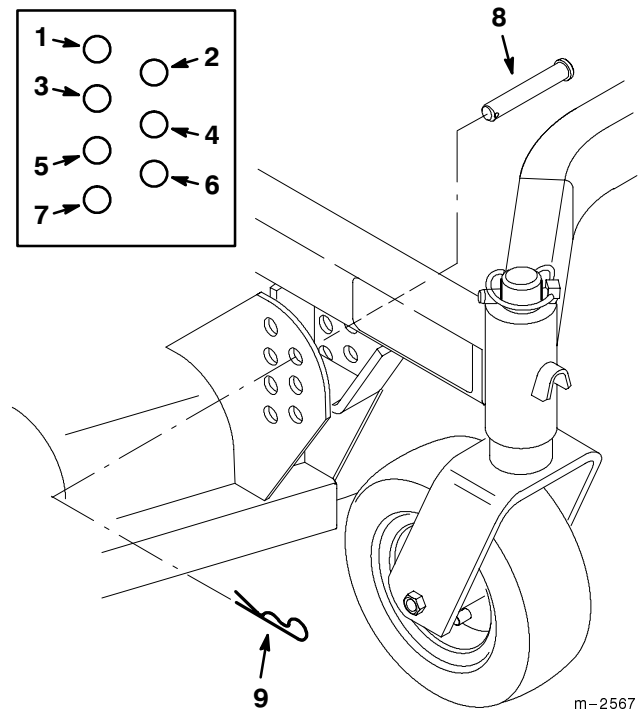

**Figure 9**

- |                                 |                                 |
|---------------------------------|---------------------------------|
| 1. 1 in. (25 mm) Cut Height     | 5. 3 in. (76 mm) Cut Height     |
| 2. 1-1/2 in. (38 mm) Cut Height | 6. 3-1/2 in. (89 mm) Cut Height |
| 3. 2 in. (51 mm) Cut Height     | 7. 4 in. (102 mm) Cut Height    |
| 4. 2-1/2 in. (64 mm) Cut Height | 8. Clevis Pin                   |
|                                 | 9. Hairpin Cotter               |

## Tips for Mowing Grass

### Fast Throttle Setting

For best mowing and maximum air circulation, operate the engine at “FAST.” Air is required to thoroughly cut grass clippings, so do not set the height-of-cut so low as to totally surround the mower by uncut grass. Always try to have one side of the mower free from uncut grass, which allows air to be drawn into the mower.

### Cutting a Lawn for the First Time

Cut grass slightly longer than normal to ensure the cutting height of the mower does not scalp any uneven ground. However, the cutting height used in the past is generally the best one to use. When cutting grass longer than six inches tall, you may want to cut the lawn twice to ensure an acceptable quality of cut.

### Cut 1/3 of the Grass Blade

It is best to cut only about 1/3 of the grass blade. Cutting more than that is not recommended unless grass is sparse, or it is late fall when grass grows more slowly.

## **Mowing Direction**

Alternate mowing direction to keep the grass standing straight. This also helps disperse clippings which enhances decomposition and fertilization.

## **Mow at Correct Intervals**

Normally, mow every four days. But remember, grass grows at different rates at different times. So to maintain the same cutting height, which is a good practice, mow more often in early spring. As the grass growth rate slows in mid summer, mow less frequently. If you cannot mow for an extended period, first mow at a high cutting height; then mow again two days later at a lower height setting.

## **Cutting Speed**

To improve cut quality, use a slower ground speed.

## **Avoid Cutting Too Low**

If the cutting width of the mower is wider than the mower you previously used, raise the cutting height to ensure that uneven turf is not cut too short.

## **Long Grass**

If the grass is ever allowed to grow slightly longer than normal, or if it contains a high degree of moisture, raise the cutting height higher than usual and cut the grass at this setting. Then cut the grass again using the lower, normal setting.

## **When Stopping**

If the machine's forward motion must be stopped while mowing, a clump of grass clippings may drop onto your lawn. To avoid this, move onto a previously cut area with the blades "ENGAGED".

## **Keep the Underside of the Mower Clean**

Clean clippings and dirt from the underside of the mower after each use. If grass and dirt build up inside the mower, cutting quality will eventually become unsatisfactory.

## **Blade Maintenance**

Maintain a sharp blade throughout the cutting season because a sharp blade cuts cleanly without tearing or shredding the grass blades. Tearing and shredding turns grass brown at the edges, which slows growth and increases the chance of disease. Check the cutter blades daily for sharpness, and for any wear or damage. File down any nicks and sharpen the blades as necessary. If a blade is damaged or worn, replace it immediately with a genuine TORO replacement blade.

# Maintenance

**Note:** Determine the left and right sides of the machine from the normal operating position.

## Recommended Maintenance Schedule

Maintenance Service Interval	Maintenance Procedure
Each Use	<ul style="list-style-type: none"> <li>Mower housing—clean</li> </ul>
5 hours	<ul style="list-style-type: none"> <li>Mower housing—clean</li> <li>Cutting blades—check</li> <li>Blade spindle bearings—grease</li> </ul>
25 hours	<ul style="list-style-type: none"> <li>Belts—check for wear/cracks</li> <li>Idler arm—oil</li> <li>Castor wheels—grease</li> </ul>
50 hours	<ul style="list-style-type: none"> <li>Mower housing—clean</li> <li>Cutting blades—check</li> <li>Gearbox—check level of lubricant</li> </ul>
At Storage	<ul style="list-style-type: none"> <li>Chipped surfaces—paint</li> <li>Perform all maintenance procedures listed above before storage</li> </ul>

**Important** Refer to your engine operator’s manual for additional maintenance procedures.

**Caution**

**If you leave the key in the ignition switch, someone could accidentally start the engine and seriously injure you or other bystanders.**

**Remove the key from the ignition and disconnect the wire from the spark plug(s) before you do any maintenance. Set the wire aside so that it does not accidentally contact the spark plug.**

## Cutting Blade Service

To ensure a superior quality of cut, keep the blades sharp. For convenient sharpening and replacement, you may want to keep extra blades on hand.

**Danger**

**A worn or damaged blade can break, and a piece of the blade could be thrown into the operator’s or bystander’s area, resulting in serious personal injury or death.**

- Inspect the blade periodically for wear or damage.**
- Replace a worn or damaged blade.**

## Before Inspecting or Servicing the Blades

Park the machine on a level surface, move the PTO ENGAGEMENT switch to “DISENGAGED” and set the parking brake. Turn the ignition key to “OFF” to stop the engine. Remove the key and disconnect the spark plug wire(s) from the spark plug(s).

## Inspecting the Blades

1. Inspect the cutting edges (Fig 10). If the edges are not sharp or have nicks, remove and sharpen the blades. Refer to Sharpening the Blades on page 13.
2. Inspect the blades, especially the curved area (Fig. 10). If you notice any damage, wear, or a slot forming in this area (Fig. 10), immediately install a new blade.

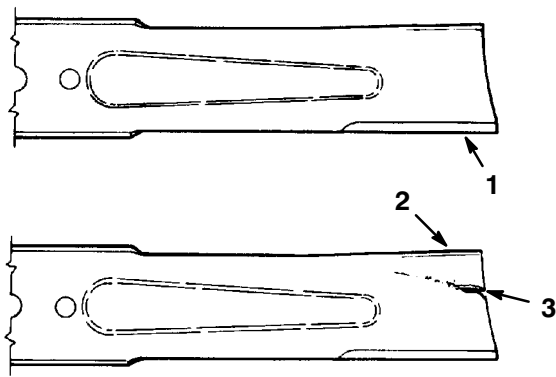

**Figure 10**

m-151

1. Cutting Edge
2. Curved Area
3. Wear/slot Forming

## Checking for Bent Blades



### Warning



**A blade that is bent or damaged could break apart and could seriously injure or kill you or bystanders.**

- **Always replace bent or damaged blade with a new blade.**
- **Never file or create sharp notches in the edges or surfaces of blade.**

1. Rotate the blades until the ends face forward and backward (Fig. 11). Measure from a level surface to the cutting edge of the blades (Fig. 12). Note this dimension.

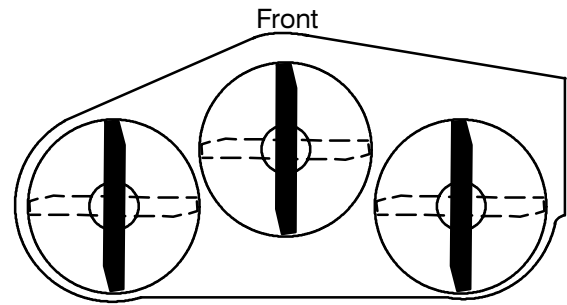

m-1078

**Figure 11**

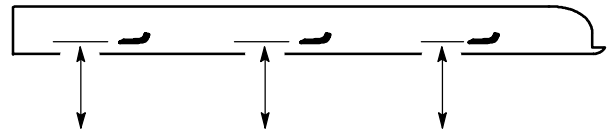

**MEASURE FROM  
CUTTING EDGE TO A  
LEVEL SURFACE**

m-2539

**Figure 12**

2. Rotate the opposite ends of the blades forward. Measure from a level surface to the cutting edge of the blades at the same position as in step 1 above. The difference between the dimensions obtained in steps 1 and 2 must not exceed 1/8 in. (3 mm). If this dimension exceeds 1/8 in. (3 mm), the blade is bent and must be replaced. Refer to Removing the Blades, and Installing the Blades on page 13.

## Removing the Blades

Blades must be replaced if a solid object is hit, if the blade is out of balance or is bent. To ensure optimum performance and continued safety conformance of the machine, use genuine TORO replacement blades. Replacement blades made by other manufacturers may result in non-conformance with safety standards.

Hold the blade end using a rag or thickly-padded glove. Remove the blade bolt, lock washer, anti-scalp cup and blade from the spindle shaft (Fig. 13).

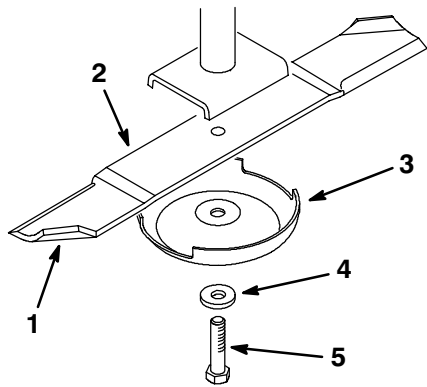

1082

**Figure 13**

- |                       |                |
|-----------------------|----------------|
| 1. Sail Area of Blade | 4. Lock Washer |
| 2. Blade              | 5. Blade Bolt  |
| 3. Anti-scalp Cup     |                |

## Sharpening the Blades

1. Use a file to sharpen the cutting edge at both ends of the blade (Fig. 14). Maintain the original angle. The blade retains its balance if the same amount of material is removed from both cutting edges.

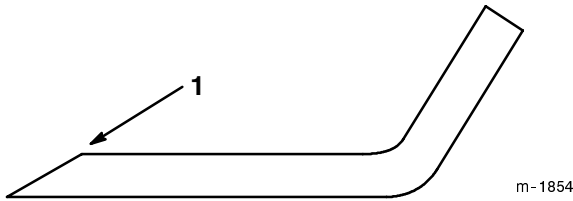

m-1854

**Figure 14**

1. Sharpen at original angle

2. Check the balance of the blade by putting it on a blade balancer (Fig. 15). If the blade stays in a horizontal position, the blade is balanced and can be used. If the blade is not balanced, file some metal off the end of the sail area only (Fig. 13). Repeat this procedure until the blade is balanced.

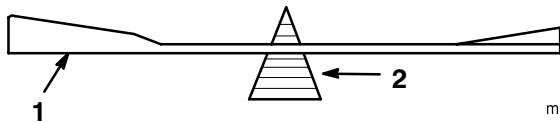

m-1855

**Figure 15**

- |          |             |
|----------|-------------|
| 1. Blade | 2. Balancer |
|----------|-------------|

## Installing the Blades

1. Install the blade and anti-scalp cup onto the spindle shaft (Fig. 13).

**Important** The curved part of the blade must be pointing upward toward the inside of the mower to ensure proper cutting.

2. Install the lock washer and blade bolt (Fig. 13). Torque the blade bolt to 85-110 ft.-lb (115-149 N•m).

## Correcting Cutting Unit Mismatch

If one cutter blade cuts lower than the other, correct as follows:

1. Stop the engine, remove the key and disconnect the spark plug wire(s) from the spark plug(s).
2. Adjust the tire pressure in all tires to specifications and check that the blades are not bent. Refer to Checking for Bent Blades on page 12.
3. Set the height-of-cut to the 3-1/2 in. (89 mm) or 4 in. (102 mm) position. Refer to Adjusting the Height-Of-Cut in the Operation section. Make sure the clevis pins are resting on the frame cushions.
4. Rotate the blades so the tips line up with one another. The blade tips must be within 1/8 in. (3 mm) of each other. If the blade tips are not within 1/8 in. (3 mm) of each other, add shim washers (Part No. 3256-24) between the appropriate spindle housing and the bottom of the cutting unit to align the blades.

## Setting the Front-to-Rear Pitch

1. Check the tire pressure.
2. Position the blades front-to-rear (Fig. 16). Measure at "C" and "D" locations (Fig. 16) from a level surface to the cutting edge of the blades (Fig. 17).
3. The mower should be 1/8 in.-5/8 in. (3-16 mm) lower in front "C" than in the rear "D".

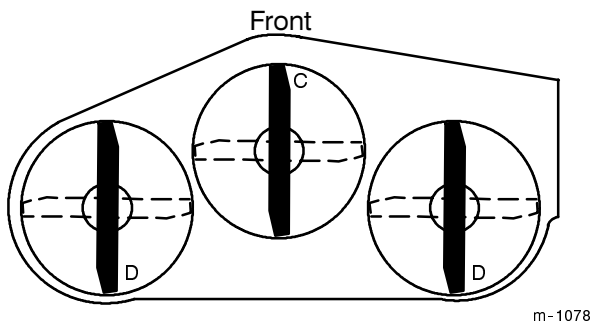
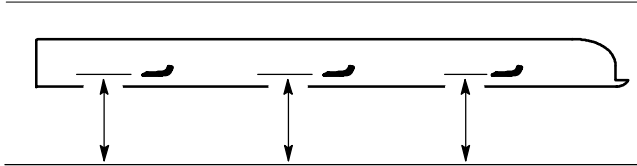

Figure 16

m-1078



MEASURE FROM  
CUTTING EDGE TO A  
LEVEL SURFACE

m-2539

Figure 17

4. To change the front-to-rear pitch, move an equal number of thrust washers on both castor wheel forks. Move the thrust washers from the top of the carrier frame mounting tube to the bottom to raise the front of the mower. Move the thrust washers from the bottom of the mounting tube to the top to lower the front of the mower. (Fig. 18).

5. Check the side-to-side leveling of the cutting unit.

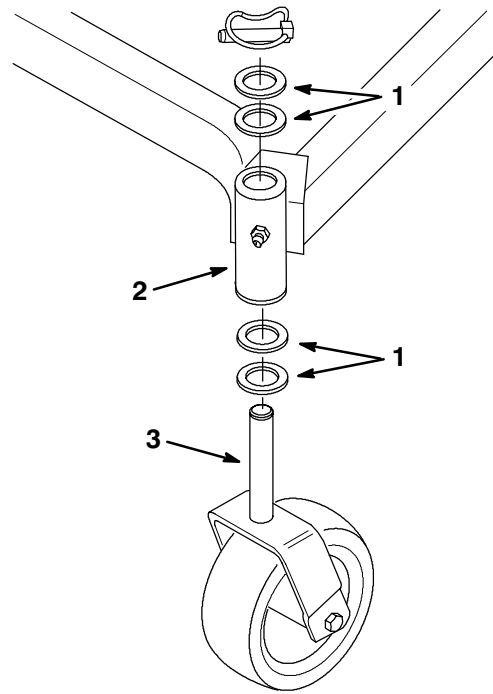

Figure 18

m-2559

1. Thrust Washer
2. Carrier Frame Mounting Tube
3. Castor Wheel Fork

### Setting the Side-to-Side Leveling

1. Check the tire pressure.
2. Position the blades side-to-side (Fig. 19). Measure at "A" and "B" locations (Fig. 19) from a level surface to the cutting edge of blades (Fig. 20).
3. The difference between measurements "A" and "B" should be no more than 1/4 in. (6 mm).

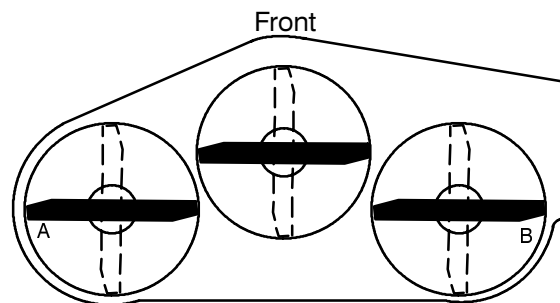
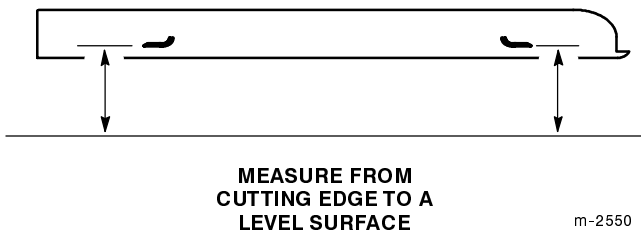

Figure 19

m-1078



**Figure 20**

4. To change the side-to-side leveling, move the thrust washers on one castor wheel fork only. Move the thrust washers from the top of the carrier frame mounting tube to the bottom to raise the corresponding side of the mower. Move the thrust washers from the bottom of the mounting tube to the top to lower the corresponding side of the mower. (Fig. 18).
5. Recheck the front-to-rear pitch of the cutting unit.

## Greasing the Bearings and Bushings

The cutting unit must be lubricated regularly. Refer to the Recommended Maintenance Schedule on page 11. Grease with No. 2 general purpose lithium base or molybdenum base grease.

1. Grease the fittings on the three spindle pulley bearings (Fig. 21).

**Note:** You can access the spindle grease fittings through the holes in the deck covers.

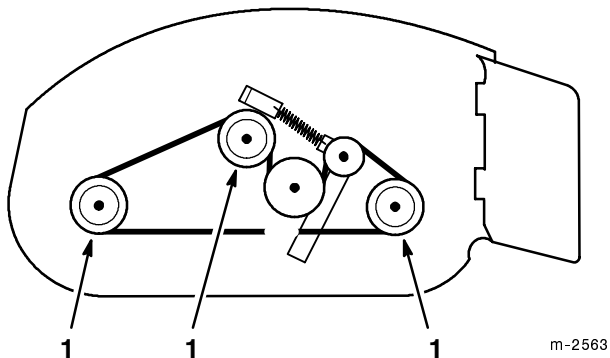

**Figure 21**  
Top View

1. Spindle Pulley

2. Grease the fittings on the carrier frame mounting tubes and castor wheels (Fig. 22).

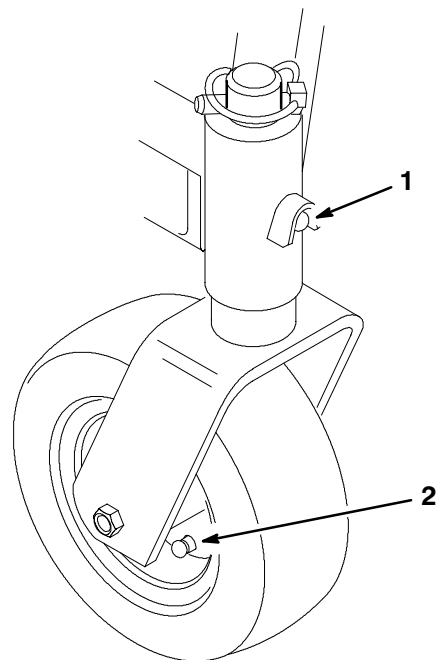
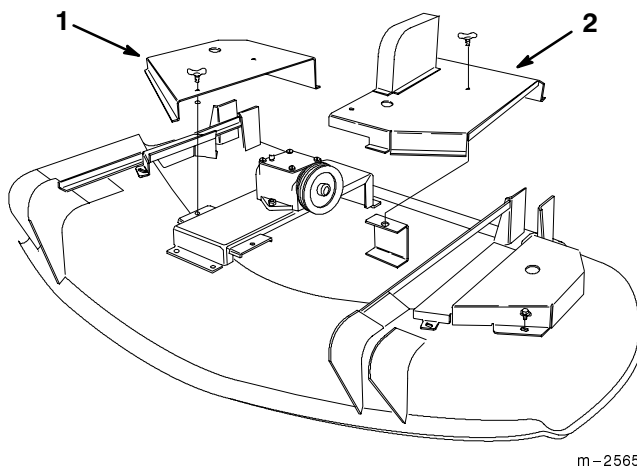

**Figure 22**

1. Carrier Frame Mounting Tube Grease Fitting
2. Castor Wheel Grease Fitting

## Servicing the Gearbox

1. Turn the wing head studs holding the left and right center deck covers 1/4 turn counterclockwise and remove both center deck covers (Fig. 23).

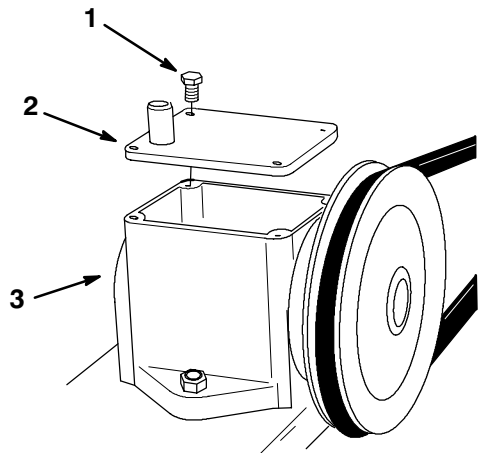

**Figure 23**

1. Right Center Deck Cover
2. Left Center Deck Cover

2. Remove the gearbox cover screws and remove the gearbox cover (Fig 24).

3. Check the oil level in the gearbox. Add SAE E.P. 90 wt. gear oil if necessary until the oil level reaches the horizontal input shaft.
4. Check the gearbox cover gasket and replace if damaged or worn.
5. Reinstall the gearbox cover, then reinstall and tighten the gearbox cover screws (Fig 24).



m-2564

**Figure 24**

1. Gearbox Cover Screw (4)
2. Gearbox Cover
3. Gearbox

6. Reinstall both center deck covers, then turn the wing head studs 1/4 turn clockwise to secure the center covers to the deck (Fig. 23).

## Replacing the Deck Belt

Squealing when the belt is rotating, blades slipping when cutting grass, frayed belt edges, burn marks and cracks are signs of a worn deck belt. Replace the deck belt if any of these conditions are evident.

1. Turn the wing head studs holding the left and right center deck covers 1/4 turn counterclockwise and remove both center deck covers (Fig. 25).
2. Remove the flange screws holding the left and right covers to the deck and remove both covers (Fig. 25).

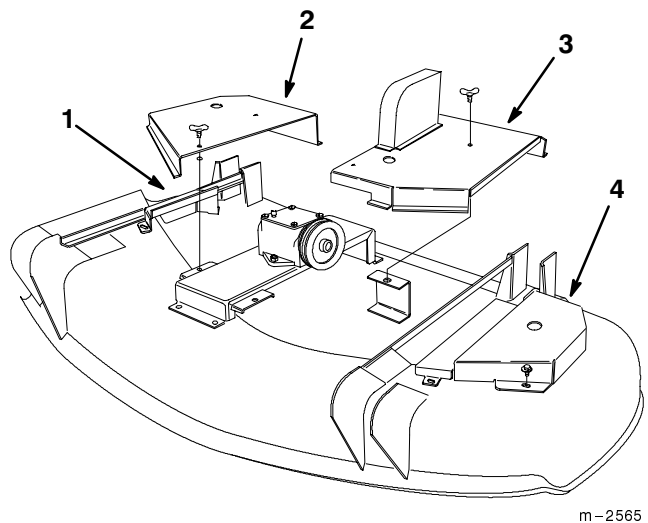

m-2565

**Figure 25**

1. Right Deck Cover
2. Right Center Deck Cover
3. Left Center Deck Cover
4. Left Deck Cover

3. Lift the idler pulley and remove the drive belt. Refer to Replacing the Drive Belt on page 17.

4. Install the new deck belt around the three spindle pulleys, gearbox output pulley and deck idler pulley (Fig. 26).

5. Reconnect the deck idler arm spring (Fig. 26).

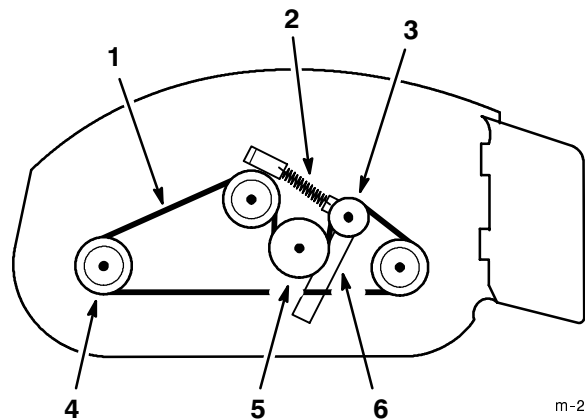

m-2563

**Figure 26**

Top View

1. Deck Belt
2. Deck Idler Arm Spring
3. Deck Idler Pulley
4. Spindle Pulley (3)
5. Gearbox Output Pulley
6. Idler Arm

6. Reinstall the drive belt. Refer to Replacing the Drive Belt, steps 3 and 4 on page 17.

7. Reinstall the four deck covers onto the cutting unit (Fig. 25).

## Replacing the Drive Belt

Squealing when the belt is rotating, blades slipping when cutting grass, frayed belt edges, burn marks and cracks are signs of a worn drive belt. Replace the drive belt if any of these conditions are evident.

1. Rotate the two wing head studs on the left center deck cover 1/4 turn counterclockwise. Remove the left center deck cover to expose the gearbox input pulley (Fig. 27).

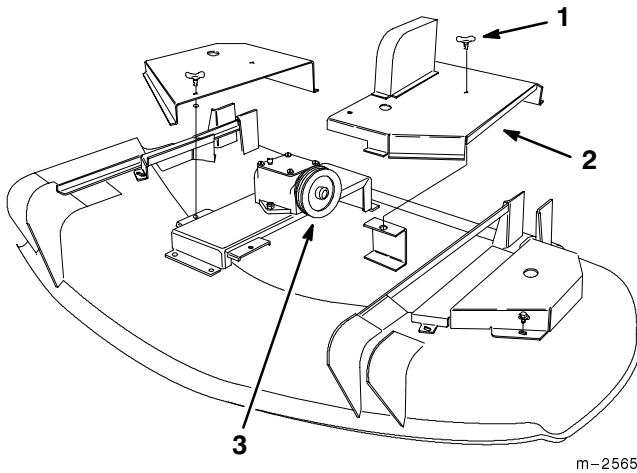

**Figure 27**

- |                             |                         |
|-----------------------------|-------------------------|
| 1. Wing Head Stud (typical) | 3. Gearbox Input Pulley |
| 2. Left Center Deck Cover   |                         |

2. Hold the idler pulley up and install the new drive belt onto the traction unit output pulley and gearbox input pulley (Fig. 28).
3. Release the idler pulley to allow it to spring back on top of the drive belt (Fig. 28).

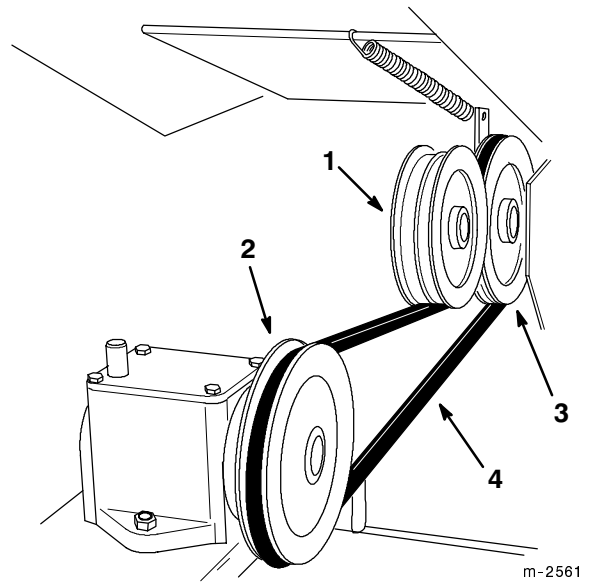

**Figure 28**

- |                         |                                |
|-------------------------|--------------------------------|
| 1. Idler Pulley         | 3. Traction Unit Output Pulley |
| 2. Gearbox Input Pulley | 4. Drive Belt                  |

4. Reinstall the left center deck cover onto the deck, then rotate the two wing head studs 1/4 turn clockwise to secure the cover to the deck (Fig. 27).

## Adjusting the Deck Idler Pulley Tension

1. Turn the wing head studs holding the left and right center deck covers 1/4 turn counterclockwise and remove both center deck covers (Fig. 29).

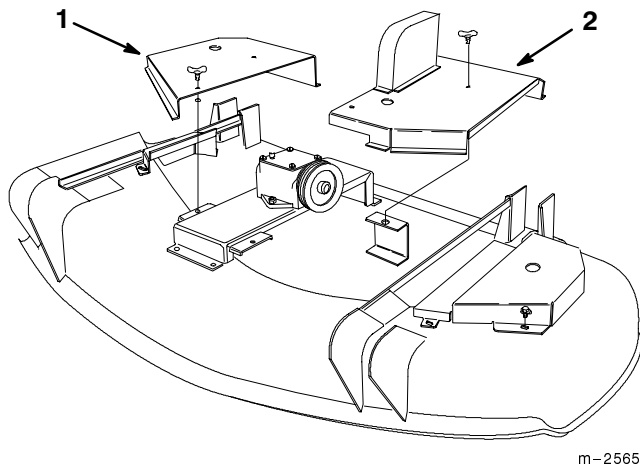

m-2565

**Figure 29**

- 1. Right Center Deck Cover
- 2. Left Center Deck Cover

- 2. Lift the spring anchor up and off of the cap screw (Fig. 30).
- 3. Reinstall the appropriate hole in the spring anchor onto the cap screw to increase the idler pulley spring pressure on the deck idler pulley (Fig. 30).

**Note:** The ideal deck idler pulley tension is between 30 and 40 pounds of force.

- 4. Reinstall and tighten the nut onto the cap screw (Fig. 30).

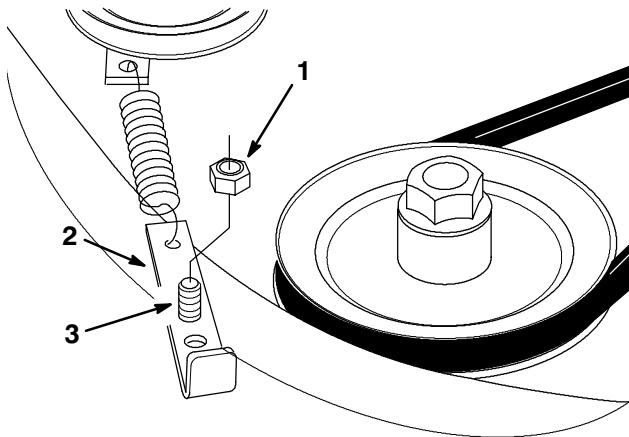

**Figure 30**

- 1. Nut
- 2. Spring Anchor
- 3. Cap Screw

- 5. Reinstall both center deck covers, then turn the wing head studs 1/4 turn clockwise to secure the covers to the deck (Fig. 29).

## Replacing the Castor Wheel Fork Bushings

The castor wheel forks are mounted in bushings pressed into the top and bottom of the carrier frame mounting tubes. To check the bushings, move the castor forks back and forth and side-to-side. If a castor fork is loose, the bushings are worn and must be replaced.

- 1. Raise the cutting unit so the castor wheels are off the floor, then block up the front of the mower with jack stands.
- 2. Remove the linchpin and thrust washer(s) from the top of the castor wheel fork (Fig. 31).
- 3. Pull the castor wheel fork out of the mounting tube, leaving the thrust washer(s) on the bottom of the fork. Remember the location of the thrust washers on each fork to ensure correct installation, and to maintain a level deck.

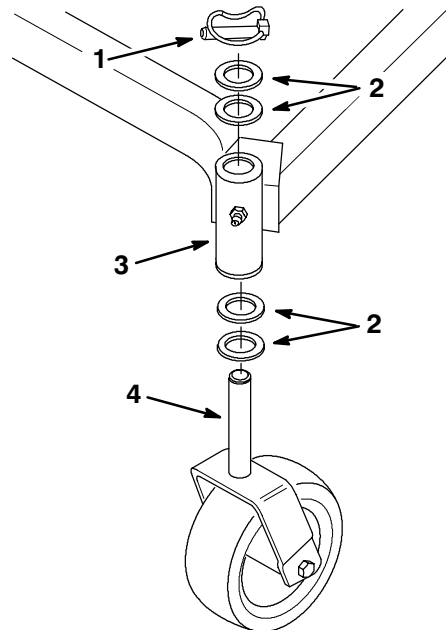

m-2559

**Figure 31**

- 1. Linchpin
- 2. Thrust Washer
- 3. Carrier Frame Mounting Tube
- 4. Castor Wheel Fork

- 4. Grease the inside and outside of the new bushings. Use a hammer and flat plate to carefully drive the bushings into the mounting tube.
- 5. Inspect the castor wheel fork for wear and replace if necessary (Fig. 31).
- 6. Slide the castor wheel fork through the bushings in the mounting tube. Replace the thrust washer(s) onto the fork and secure with the linchpin (Fig. 31).

**Important** The inside diameter of the bushings may collapse slightly when installed. If the castor wheel fork does not slide into the new bushings, ream both bushings to an inside diameter of 1.126 in. (28.6mm).

- Grease the fitting on the carrier frame mounting tube using No. 2 general purpose lithium base or molybdenum base grease.

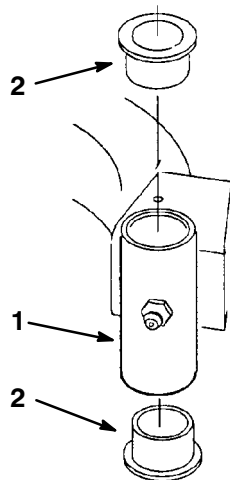

m-1076

**Figure 32**

- |                                |            |
|--------------------------------|------------|
| 1. Carrier Frame Mounting Tube | 2. Bushing |
|--------------------------------|------------|

## Servicing the Castor Wheels and Bearings

The castor wheels rotate on a roller bearing supported by a spanner bushing. If the bearing is kept well lubricated, wear will be minimal. Failure to keep the bearing well lubricated will cause rapid wear. A wobbly castor wheel usually indicates a worn bearing.

- Remove the locknut and wheel bolt holding the castor wheel to the castor fork (Fig. 33).
- Remove the washer and bushing, then pull the spanner bushing and roller bearing out of the wheel hub (Fig. 33).
- Remove the other washer and bushing from the wheel hub and clean any grease and dirt from the wheel hub (Fig. 33).
- Inspect the roller bearing, bushings, spanner bushing and inside of the wheel hub for wear. Replace any defective or worn parts (Fig. 33).

- Install the washers on the outsides of the bushings, then install the castor wheel into the castor fork and secure with the wheel bolt and locknut. Tighten the locknut until the spanner bushing bottoms against the inside of the castor fork (Fig. 33).
- Grease the fitting on the castor wheel.

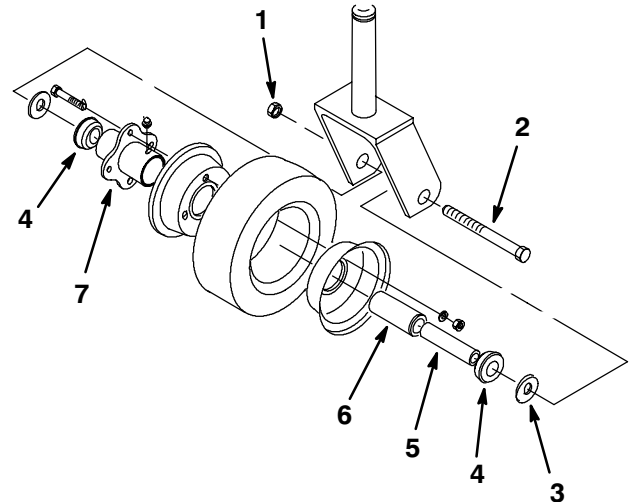

m-1090

**Figure 33**

- |               |                    |
|---------------|--------------------|
| 1. Locknut    | 5. Spanner Bushing |
| 2. Wheel Bolt | 6. Roller Bearing  |
| 3. Washer     | 7. Wheel Hub       |
| 4. Bushing    |                    |

## Replacing the Grass Deflector

- Remove the locknuts, bolts and springs holding the deflector mounts to the pivot brackets (Fig. 34).
- If the pivot brackets need to be replaced, remove the carriage bolts and cone locknuts holding the old brackets to the top of the discharge opening, then install the replacement pivot brackets. Make sure the carriage bolt heads are on the inside of the cutting unit (Fig. 34).
- Install the deflector mounts between the pivot brackets with the bolts, springs and locknuts. Make sure the straight ends of the springs are positioned between the deflector mounts and the grass deflector (Fig. 34).
- Tighten the locknuts until they contact the pivot brackets (Fig. 34).

**Important** The grass deflector must be spring-loaded in the down position. Lift the deflector up to test that it snaps to the full down position.

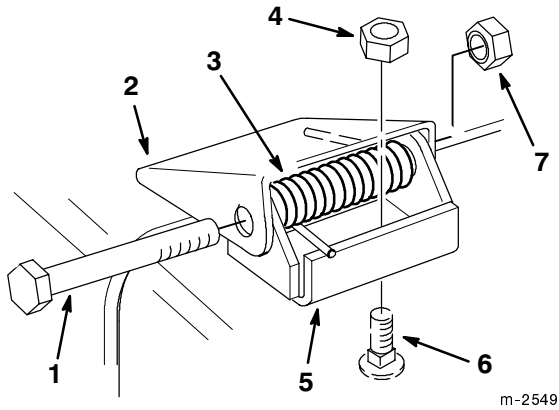

**Figure 34**

- |                    |                  |
|--------------------|------------------|
| 1. Bolt            | 5. Pivot Bracket |
| 2. Deflector Mount | 6. Carriage Bolt |
| 3. Spring          | 7. Locknut       |
| 4. Cone Locknut    |                  |

## Storage

1. Clean any dirt and chaff from the top of the mower.
2. Scrape any heavy buildup of grass and dirt from the underside of the mower, then wash the mower with a garden hose.
3. Check the condition of the blades. Refer to Cutting Blades on page 11.
4. Check the condition of the drive and deck belts.
5. Check and tighten all bolts, nuts and screws. Repair or replace any part that is damaged or defective.
6. Paint all scratched or bare metal surfaces. Paint is available from your Authorized Service Dealer.
7. Store the machine in a clean, dry garage or storage area. Cover the machine to protect it and keep it clean.

## Troubleshooting

PROBLEM	POSSIBLE CAUSES	CORRECTIVE ACTION
Abnormal vibration.	<ol style="list-style-type: none"> <li>1. Cutting blade(s) is/are bent or unbalanced.</li> <li>2. Blade mounting bolt is loose.</li> <li>3. Engine mounting bolts are loose.</li> <li>4. Loose engine pulley, idler pulley, or blade pulley.</li> <li>5. Engine pulley is damaged.</li> <li>6. Blade spindle bent.</li> </ol>	<ol style="list-style-type: none"> <li>1. Install new cutting blade(s).</li> <li>2. Tighten blade mounting bolt.</li> <li>3. Tighten engine mounting bolts.</li> <li>4. Tighten the appropriate pulley.</li> <li>5. Contact Authorized Service Dealer.</li> <li>6. Contact Authorized Service Dealer.</li> </ol>
Uneven cutting height.	<ol style="list-style-type: none"> <li>1. Blade(s) not sharp.</li> <li>2. Cutting blade(s) is/are bent.</li> <li>3. Mower is not level.</li> <li>4. Underside of mower is dirty.</li> <li>5. Tire pressure is incorrect.</li> <li>6. Blade spindle bent.</li> </ol>	<ol style="list-style-type: none"> <li>1. Sharpen blade(s).</li> <li>2. Install new cutting blade(s).</li> <li>3. Level mower from side-to-side and front-to-rear.</li> <li>4. Clean the underside of the mower.</li> <li>5. Adjust tire pressure.</li> <li>6. Contact Authorized Service Dealer.</li> </ol>

PROBLEM	POSSIBLE CAUSES	CORRECTIVE ACTION
Blades do not rotate.	<ol style="list-style-type: none"> <li>1. Drive belt is worn, loose or broken.</li> <li>2. Drive belt is off pulley.</li> <li>3. Deck belt is worn, loose or broken.</li> <li>4. Deck idler pulley tension is too loose.</li> <li>5. Deck belt is off pulley.</li> </ol>	<ol style="list-style-type: none"> <li>1. Install new drive belt.</li> <li>2. Install drive belt and check traction unit idler pulley, idler arm and spring for correct position and function.</li> <li>3. Install new deck belt.</li> <li>4. Reposition the spring anchor on the deck.</li> <li>5. Install deck pulley and check the idler pulley, idler arm and spring for correct position and function.</li> </ol>





