



**Groundsmaster® 120**  
**Groundsmaster Traction Unit**  
Model No. 30611-21000001 & Up

**Operator's Manual**



## Warning



**The engine exhaust from this product contains chemicals known to the State of California to cause cancer, birth defects, or other reproductive harm.**

**Important** This engine is not equipped with a spark arrester muffler. It is a violation of California Public Resource Code Section 4442 to use or operate this engine on any forest-covered, brush-covered or grass-covered land. Other states or federal areas may have similar laws.

This spark ignition system complies with Canadian ICES-002.

Ce système d'allumage par étincelle de véhicule est conforme à la norme NMB-002 du Canada.

**The enclosed Engine Owner's Manual is supplied for information regarding The U.S. Environmental Protection Agency (EPA) and the California Emission Control Regulation of emission systems, maintenance and warranty.**

**Keep this engine Owner's Manual with your unit. Should this engine Owner's Manual become damaged or illegible, replace immediately. Replacements may be ordered through the engine manufacturer.**

# Contents

	Page
Introduction .....	2
Safety .....	3
Safe Operation Practices for Ride-on (riding)	
Rotary Lawnmower Machines .....	3
Slope Chart .....	7
Safety and Instruction Decals .....	9
Gasoline and Oil .....	12
Recommended Gasoline .....	12
Using Stabilizer/Conditioner .....	12
Filling the Fuel Tank .....	12
Check Engine Oil Level .....	12
Assembly .....	13
Loose Parts .....	13
Install Seat .....	13
Install Steering Wheel .....	14
Install Rear Weights .....	14
Activate the Battery .....	14
Install the Battery .....	15
Check Engine Oil .....	15
Check Hydraulic System Fluid .....	15
Operation .....	15

	Page
Think Safety First .....	15
Starting and Stopping the Engine .....	16
Operating the Power Take Off (PTO) .....	16
Driving Forward or Backward .....	17
Parking Brake .....	17
Implement Lift Lever .....	18
The Safety Interlock System .....	18
Positioning the Seat .....	19
Pushing or Towing the Machine .....	19
Maintenance .....	20
Recommended Maintenance Schedule .....	20
Belt Guard .....	21
Air Cleaner Service .....	21
Engine Oil Service .....	22
Spark Plug .....	23
Greasing and Lubrication .....	24
Brake .....	25
Fuel Filter .....	26
Tire Pressure .....	26
Cleaning the Cooling System .....	27
Adjust Belts .....	27
Replace Belts .....	27
Adjust Lift Cylinder and Counterbalance Springs .....	28
Adjust Transmission Neutral .....	28
Adjust Electric Clutch .....	29
Check Hydraulic System Fluid .....	30
Change Hydraulic System Oil .....	30
Change Hydraulic Oil Filter .....	31
Adjust Steering .....	31
Hydraulic Schematic .....	32
Change Front Axle Oil .....	32
Battery Service .....	33
Wire Harness Service .....	34
Waste Disposal .....	34
Transporting Machines .....	34
Wiring Diagram .....	35
Cleaning and Storage .....	36
Troubleshooting .....	36

# Introduction

Read this manual carefully to learn how to operate and maintain your product properly. The information in this manual can help you and others avoid injury and product damage. Although Toro designs and produces safe products, you are responsible for operating the product properly and safely.

Whenever you need service, genuine Toro parts, or additional information, contact an Authorized Service Dealer or Toro Customer Service and have the model and

serial numbers of your product ready. Figure 1 illustrates the location of the model and serial numbers on the product.

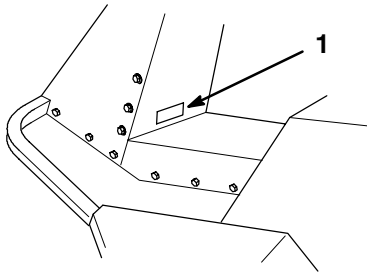

m-2196

**Figure 1**

1. Location of the model and serial numbers

Write the product model and serial numbers in the space below:

<b>Model No.</b> _____
<b>Serial No.</b> _____

This manual identifies potential hazards and has special safety messages that help you and others avoid personal injury and even death. **Danger**, **Warning**, and **Caution** are signal words used to identify the level of hazard. However, regardless of the hazard, be extremely careful.

**Danger** signals an extreme hazard that *will* cause serious injury or death if you do not follow the recommended precautions.

**Warning** signals a hazard that *may* cause serious injury or death if you do not follow the recommended precautions.

**Caution** signals a hazard that may cause minor or moderate injury if you do not follow the recommended precautions.

This manual uses two other words to highlight information. **Important** calls attention to special mechanical information and **Note**: emphasizes general information worthy of special attention.

# Safety

## Safe Operation Practices for Ride-on (riding) Rotary Lawnmower Machines

This machine meets or exceeds European Standards in effect at the time of production. However, improper use or maintenance by the operator or owner can result in injury. To reduce the potential for injury, comply with these safety instructions and always pay attention to the safety alert  symbol, which means CAUTION, WARNING, or DANGER—"personal safety instruction." Failure to comply with the instruction may result in personal injury or death.

## Safe Operating Practices

The following instructions are from the CEN standard EN 836:1997.

This product is capable of amputating hands and feet and throwing objects. Always follow all safety instructions to avoid serious injury or death.

## Training

- Read the instructions carefully. Be familiar with the controls and the proper use of the equipment.
- Never allow children or people unfamiliar with these instructions to use the lawnmower. Local regulations can restrict the age of the operator.
- Never mow while people, especially children, or pets are nearby.
- Keep in mind that the operator or user is responsible for accidents or hazards occurring to other people or their property.
- Do not carry passengers.
- All drivers should seek and obtain professional and practical instruction. Such instruction should emphasize:

- the need for care and concentration when working with ride-on machines;
- control of a ride-on machine sliding on a slope will not be regained by the application of the brake. The main reasons for loss of control are:
  - insufficient wheel grip;
  - being driven too fast;
  - inadequate braking;
  - the type of machine is unsuitable for its task;
  - lack of awareness of the effect of ground conditions, especially slopes;
  - incorrect hitching and load distribution.

## Preparation

- While mowing, always wear substantial footwear and long trousers. Do not operate the equipment when barefoot or wearing open sandals.
- Thoroughly inspect the area where the equipment is to be used and remove all objects which may be thrown by the machine.
- **WARNING** - Fuel is highly flammable.
  - Store fuel in containers specifically designed for this purpose.
  - Refuel outdoors only and do not smoke while refuelling.
  - Add fuel before starting the engine. Never remove the cap of the fuel tank or add fuel while the engine is running or when the engine is hot.
  - If fuel is spilled, do not attempt to start the engine but move the machine away from the area of spillage and avoid creating any source of ignition until fuel vapors have dissipated.
  - Replace all fuel tanks and container caps securely.
- Replace faulty silencers.
- Before using, always visually inspect to see that the blades, blade bolts and cutter assembly are not worn or damaged. Replace worn or damaged blades and bolts in sets to preserve balance.
- On multi-bladed machines, take care as rotating one blade can cause other blades to rotate.

## Operation

- Do not operate the engine in a confined space where dangerous carbon monoxide fumes can collect.
- Mow only in daylight or in good artificial light.
- Before attempting to start the engine, disengage all blade attachment clutches and shift into neutral.
- Do not use on slopes of more than
  - 5° when mowing on side hills;
  - 10° when mowing uphill;
  - 15° when mowing downhill.
- Remember there is no such thing as a “safe” slope. Travel on grass slopes requires particular care. To guard against overturning:
  - do not stop or start suddenly when going up or downhill;
    - engage clutch slowly, always keep machine in gear, especially when travelling downhill;
  - machine speeds should be kept low on slopes and during tight turns;
  - stay alert for humps and hollows and other hidden hazards;
  - never mow across the face of the slope, unless the lawnmower is designed for this purpose.
- Use care when pulling loads or using heavy equipment.
  - Use only approved drawbar hitch points.
  - Limit loads to those you can safely control.
  - Do not turn sharply. Use care when reversing.
  - Use counterweight(s) or wheel weights when suggested in the instruction handbook.
- Watch out for traffic when crossing or near roadways.
- Stop the blades rotating before crossing surfaces other than grass.

- When using any attachments, never direct discharge of material toward bystanders nor allow anyone near the machine while in operation.
- Never operate the machine with defective guards or without safety protective devices in place.
- Do not change the engine governor settings or overspeed the engine. Operating the engine at excessive speed can increase the hazard of personal injury.
- Before leaving the operator's position:
  - disengage the power take-off and lower the attachments;
  - change into neutral and set the parking brake;
  - stop the engine and remove the key.
- Disengage drive to attachments, stop the engine, and disconnect the spark plug wire(s) or remove the ignition key
  - before clearing blockages or unclogging chute;
  - before checking, cleaning or working on the lawnmower;
  - after striking a foreign object. Inspect the lawnmower for damage and make repairs before restarting and operating the equipment;
  - if the machine starts to vibrate abnormally (check immediately).
- Disengage drive to attachments when transporting or not in use.
- Stop the engine and disengage drive to attachment
  - before refuelling;
  - before removing the grass catcher;
  - before making height adjustment unless adjustment can be made from the operator's position.
- Reduce the throttle setting during engine run-out and, if the engine is provided with a shut-off valve, turn the fuel off at the conclusion of mowing.

## Maintenance and Storage

- Keep all nuts, bolts and screws tight to be sure the equipment is in safe working condition.
- Never store the equipment with fuel in the tank inside a building where fumes can reach an open flame or spark.
- Allow the engine to cool before storing in any enclosure.
- To reduce the fire hazard, keep the engine, silencer, battery compartment and fuel storage area free of grass, leaves, or excessive grease.
- Check the grass catcher frequently for wear or deterioration.
- Replace worn or damaged parts for safety.
- If the fuel tank has to be drained, this should be done outdoors.
- On multi-bladed machines, take care as rotating one blade can cause other blades to rotate.
- When machine is to be parked, stored or left unattended, lower the cutting means unless a positive mechanical lock is used.

## Sound Pressure

This unit has an equivalent continuous A-weighted sound pressure at the operator ear of: 88 dB(A), based on measurements of identical machines per ANSI B71.5-1984 procedure.

## Sound Power

This unit has a power level of: 104 dB(A)/1pW, based on measurements of identical machines per Directive 84/538/EEC and amendments.

## Vibration Level

This unit has a maximum hand-arm vibration level of 6.1 m/s<sup>2</sup>, and whole body vibration level of 0.16 m/s<sup>2</sup>, based on measurements of identical machines per ISO 5349.

## **Toro Riding Mower Safety**

The following list contains safety information specific to Toro products or other safety information that you must know that is not included in the CEN standard.

- Use only Toro-approved attachments. Warranty may be voided if used with unapproved attachments.

# Slope Chart

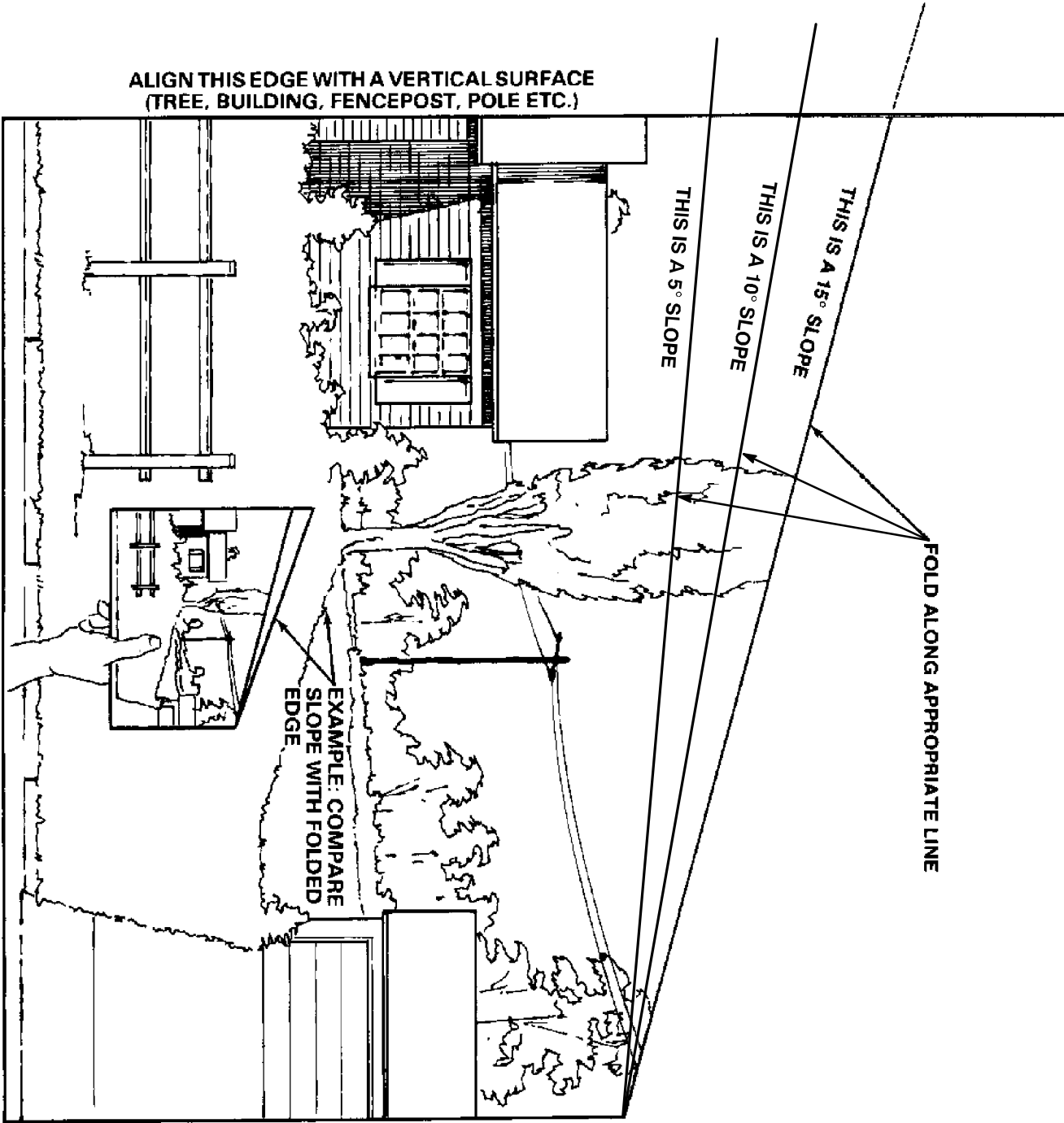



# Safety and Instruction Decals



Safety decals and instructions are easily visible to the operator and are located near any area of potential danger. Replace any decal that is damaged or lost.

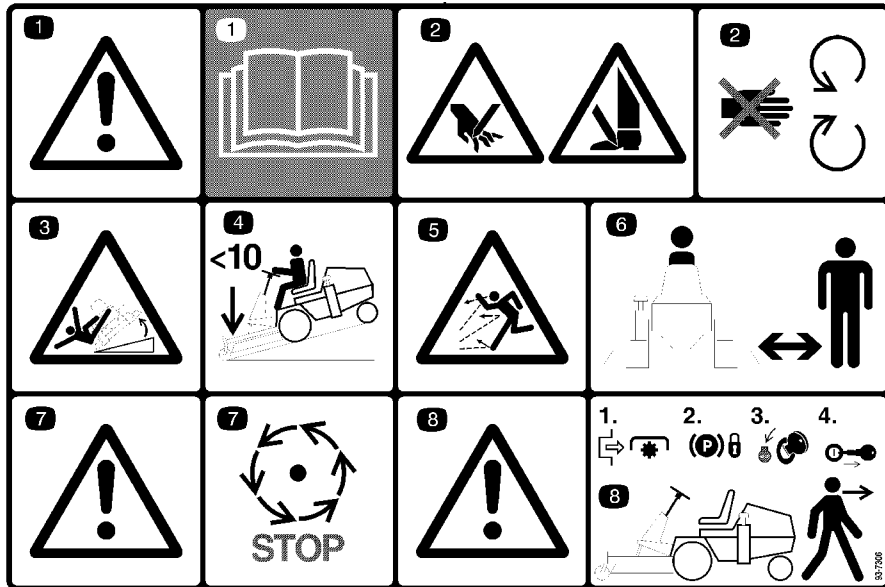

**Part No. 92-6288**

- |   |   |   |   |
|---|---|---|---|
| 1. Danger—read and understand the operator's manual.  | 3. Tipping hazard   | 6. Thrown object hazard—keep bystanders away.       | 8. Danger—disengage PTO, set parking brake, shut off engine and remove key before leaving operator position |
| 2. Cutting/dismemberment hazard of hands or feet—stay away from rotating blades and moving parts. | 4. Tipping hazard—do not go down slopes greater than 10 degrees | 7. Danger—let all moving parts stop before touching |   |
|   | 5. Thrown object hazard—keep bystanders away.                   |   |   |

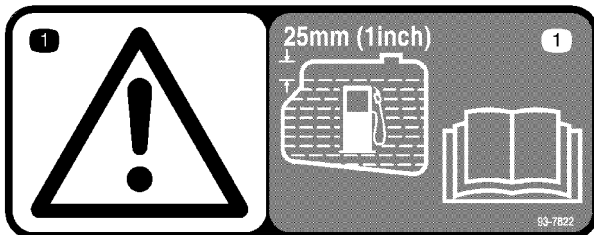

**Part No. 93-7822**

1. Danger—read and understand the operator's manual for filling fuel

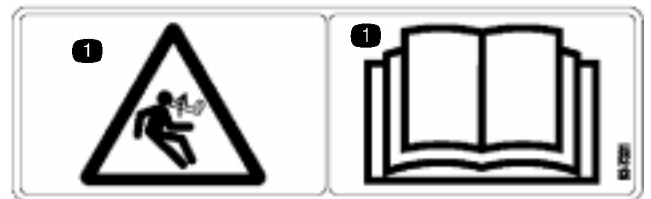

**Part No. 93-7331**

1. Danger—machine can release without intention, read and understand the operator's manual for filling fuel



**Part No. 93-7276**

- 1. Explosion hazard
- 2. Caustic liquid hazard—burns to hand and damage to items
- 3. No sparks, flame, or smoking
- 4. Caution—toxic
- 5. Wear eye protection
- 6. First Aid—flush with water
- 7. No sparks, flame, or smoking
- 8. Keep bystanders away

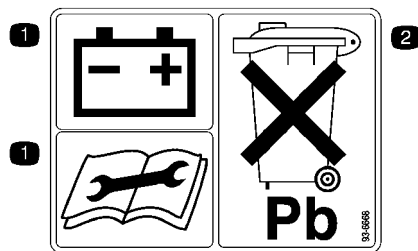

**Part No. 93-6668**

- 1. Battery charging—read operator manual for maintenance
- 2. Do not throw through battery in trash

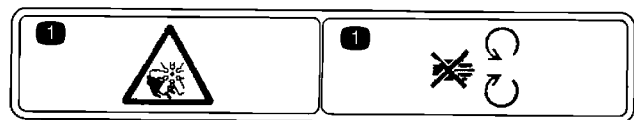

**Part No. 93-7272**

- 1. Cutting/dismemberment hazard of hands or feet—stay away from rotating blades and moving parts.

**PROLINE 120 QUICK REFERENCE AID**

**CHECK/SERVICE**

1. OIL LEVELS (ENGINE/TRANS)
2. AXLE OIL
3. TIRE PRESSURE
4. BELT TENSION (TRANS, PTO)
5. FUEL-GAS ONLY
6. BATTERY
7. GREASE, LUBE POINTS
8. ADJUST PARKING BRAKE
9. AIR CLEANER
10. ELECTRIC CLUTCH GAP .012-.018
11. DEBRIS UNDER HOOD & SEAT PLATE & ENGINE COOLING FINS

FLUID SPECIFICATION \* SEE OPERATOR'S MANUAL FOR INITIAL CHANGE

A. ENGINE OIL*	TYPE >32*	TYPE <32*	CAPACITY	CHANGE INTERVALS	FILTER PART NO.
	SAE 10W-30 OR 10W-40 SF OR SG	SAE 5W-20 OR 5W-30 SF OR SG	4 PT.	50 HRS.	FILTER 100 HRS KOHLER 12-350-01
B. TRANS OIL	SAE 10W-30 SF-CC-CD	TYPE F OR FA TRANS FLUID	5 QT.	250 HRS.	FILTER 250 HRS 54-0110
C. FUEL	UNLEADED FUEL		5 GAL.	—	FILTER 400 HRS 38-8000
D. AXLE OIL	SAE E.R 90 WT.		44 OZ.	500 HRS	
E. AIR FILTER	STANDARD				33-1300

**Part No. 92-6288**

- 1. Read and understand the operator's manual.

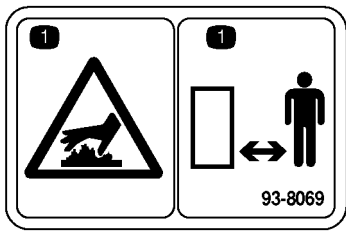

**Part No. 93-8069**

1. Caution hot—stay away

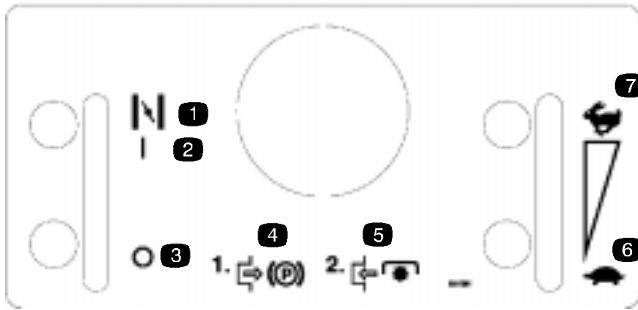

**Part No. 93-7281**

- |                |                  |
|----------------|------------------|
| 1. Fast        | 2. On            |
| 2. Slow        | 3. Stop          |
| 3. Stop engine | 4. Disengage PTO |
| 4. Lights      | 5. Engage PTO    |
| 5. On/Run      | 6. Fast          |
| 6. Start       | 7. Slow          |
1. Choke

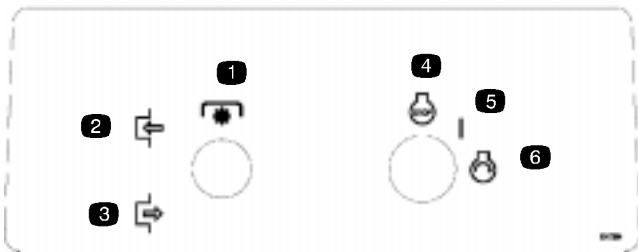

**Part No. 93-7284**

- |                  |                |
|------------------|----------------|
| 1. PTO           | 4. Stop engine |
| 2. Engage PTO    | 5. On/Run      |
| 3. Disengage PTO | 6. Start       |

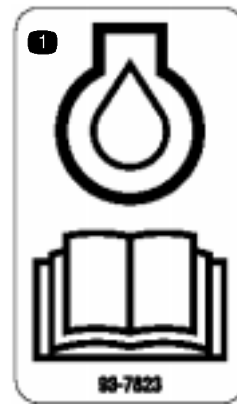

**Part No. 93-7823**

1. Engine Oil—read operator manual

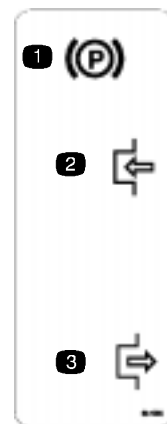

**Part No. 93-7296**

- |                         |                            |
|-------------------------|----------------------------|
| 1. Parking brake        | 3. Disengage parking brake |
| 2. Engage parking brake |                            |

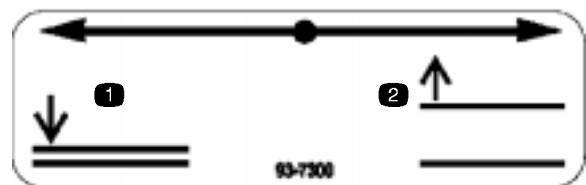

**Part No. 93-7300**

- |                     |                     |
|---------------------|---------------------|
| 1. Lower attachment | 2. Raise attachment |
|---------------------|---------------------|



**Part No. 98-4387**



1. Danger—wear hearing protection

# Gasoline and Oil

## Recommended Gasoline



Use UNLEADED Regular Gasoline suitable for automotive use (85 pump octane minimum). Leaded regular gasoline may be used if unleaded regular is not available.

**Important** Never use methanol, gasoline containing methanol, or gasohol containing more than 10% ethanol because the fuel system could be damaged. Do not mix oil with gasoline.

 **Danger** 

**In certain conditions, gasoline is extremely flammable and highly explosive. A fire or explosion from gasoline can burn you and others and can damage property.**

- **Fill the fuel tank outdoors, in an open area, when the engine is cold. Wipe up any gasoline that spills.**
- **Do not fill the fuel tank completely full. Add gasoline to the fuel tank until the level is 1/4" to 1/2" (6 mm to 13 mm) below the bottom of the filler neck. This empty space in the tank allows gasoline to expand.**
- **Never smoke when handling gasoline, and stay away from an open flame or where gasoline fumes may be ignited by a spark.**
- **Store gasoline in an approved container and keep it out of the reach of children. Never buy more than a 30-day supply of gasoline.**
- **Always place gasoline containers on the ground away from your vehicle before filling.**
- **Do not fill gasoline containers inside a vehicle or on a truck or trailer bed because interior carpets or plastic truck bed liners may insulate the container and slow the loss of any static charge.**
- **When practical, remove gas-powered equipment from the truck or trailer and refuel the equipment with its wheels on the ground.**
- **If this is not possible, then refuel such equipment on a truck or trailer from a portable container, rather than from a gasoline dispenser nozzle.**
- **If a gasoline dispenser nozzle must be used, keep the nozzle in contact with the rim of the fuel tank or container opening at all times until fueling is complete.**

 **Warning** 

**Gasoline is harmful or fatal if swallowed. Long-term exposure to vapors can cause serious injury and illness.**

- **Avoid prolonged breathing of vapors.**
- **Keep face away from nozzle and gas tank or conditioner opening.**
- **Keep gas away from eyes and skin.**

## Using Stabilizer/Conditioner

Use a fuel stabilizer/conditioner in the machine to provide the following benefits:

- Keeps gasoline fresh during storage of 90 days or less. For longer storage it is recommended that the fuel tank be drained.
- Cleans the engine while it runs
- Eliminates gum-like varnish buildup in the fuel system, which causes hard starting

**Important** Do not use fuel additives containing methanol or ethanol.

Add the correct amount of gas stabilizer/conditioner to the gas.

**Note:** A fuel stabilizer/conditioner is most effective when mixed with fresh gasoline. To minimize the chance of varnish deposits in the fuel system, use fuel stabilizer at all times.

## Filling the Fuel Tank

1. Shut the engine off and set the parking brake.
2. Clean around each fuel tank cap and remove the cap. Add unleaded regular gasoline to both fuel tanks, until the level is 1/4 to 1/2 inch (6 mm to 13 mm) below the bottom of the filler neck. This space in the tank allows gasoline to expand. Do not fill the fuel tanks completely full.
3. Install fuel tank caps securely. Wipe up any gasoline that may have spilled.

## Check Engine Oil Level

Before you start the engine and use the machine, check the oil level in the engine crankcase; refer to Checking Oil Level, page 22.

# Assembly

**Note:** Determine the left and right sides of the machine from the normal operating position.

## Loose Parts

**Note:** Use the chart below to verify all parts have been shipped.

DESCRIPTION	QTY.	USE
Spacer	1	Install steering wheel
Steering wheel	1	
Roll pin 1/4 x 2-1/2 in.(64 mm)	1	
Seat	1	Install seat
Bolt 5/16-18 x 1 in. (25 mm)	4	
Lock nut 5/16-18	4	
R-clamp	1	
Weight	2	Install on rear weight
Bolt 1/2-13 x 3-1/2 in. (89 mm)	4	
Washer 1/2 in. (13 mm)	4	
Lock washer 1/2 in. (13 mm)	4	
Nut 1/2"	4	
Carriage bolt 1/4-20 x 3/4 in. (19 mm)	2	Install battery cables
Wing nut 1/4-20	2	
Operator's Manual	1	Read before operating machine
Parts catalog	1	
Registration card	1	Fill out and return to Toro

## Install Seat

1. Position seat assembly onto seat plate aligning mounting holes (Fig. 1).
2. Slide wire clamp over seat switch wire (Fig. 1).
3. Using left front hole, loosely secure wire clamp and seat to seat base with capscrews and lock nuts (Fig. 1).
4. Mount seat to seat base with (3) remaining bolts and lock nuts.
5. Rout seat switch wire thru slot in seat plate and plug connector onto seat switch (Fig. 1).
6. Tighten all lock nuts and check operation of seat.
7. Make sure wire harness is clear of lift arm and all moving parts.

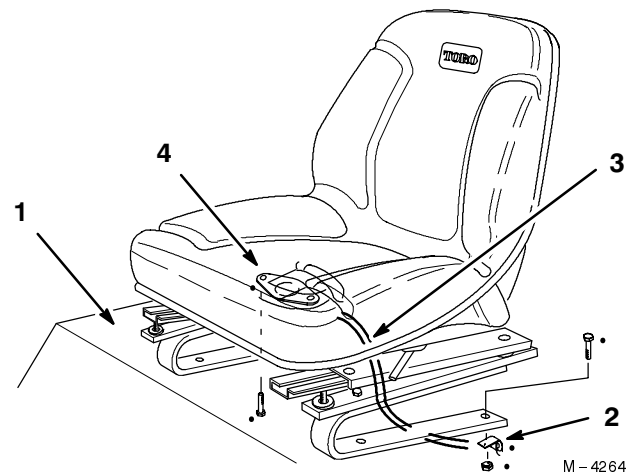

**Figure 1**

- |               |                          |
|---------------|--------------------------|
| 1. Seat plate | 3. Seat switch wire      |
| 2. R-clamp    | 4. Seat switch connector |

M-4264

## Install Steering Wheel

1. Move rear wheels so they point straight ahead.
2. Slide spacer and steering wheel onto steering shaft aligning mounting holes. Check that logo on steering cap points forward.
3. Secure steering wheel to shaft with roll pin (Fig. 2).

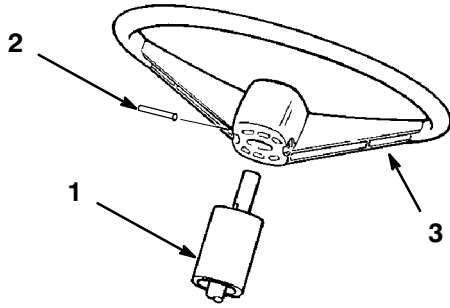

M-4263

Figure 2

- |             |                   |
|-------------|-------------------|
| 1. Spacer   | 3. Steering Wheel |
| 2. Roll pin |                   |

## Install Rear Weights

1. Attach two (2) weights onto existing weight with (4) 1/2 x 3-1/2" (89 mm) bolts, (4 ea.) 1/2" washers, 1/2" lock washers and 1/2" nuts (Fig. 3).

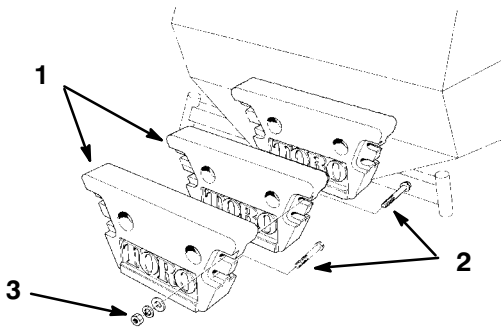

m-2907

Figure 3

- |                                 |                                |
|---------------------------------|--------------------------------|
| 1. Weight                       | 3. Washer, lock washer and nut |
| 2. Bolt 1/2 x 3-1/2 in. (89 mm) |                                |

## Activate the Battery

Bulk electrolyte with 1.260 specific gravity must be purchased from a local battery supply outlet.

1. If already installed, remove the battery from the holder.



**Danger**



**Battery electrolyte contains sulfuric acid which is a deadly poison and causes severe burns.**

- Do not drink electrolyte and avoid contact with skin, eyes or clothing. Wear safety glasses to shield your eyes and rubber gloves to protect your hands.
- Fill the battery where clean water is always available for flushing the skin.
- Follow all instructions and comply with all safety messages on the electrolyte container.

2. Remove filler caps from the battery. Slowly pour electrolyte into each cell until the electrolyte level is up to the lower part of the tube (Fig. 4).

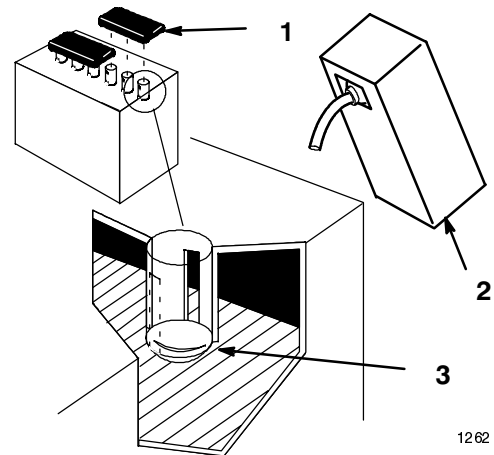

1262

Figure 4

- |                |                           |
|----------------|---------------------------|
| 1. Filler caps | 3. Lower part of the tube |
| 2. Electrolyte |                           |

3. Leave the covers off and connect a 3 to 4 amp battery charger to the battery posts (Fig. 5). Charge the battery at a rate of 4 amperes or less for 4 hours (12 volts).

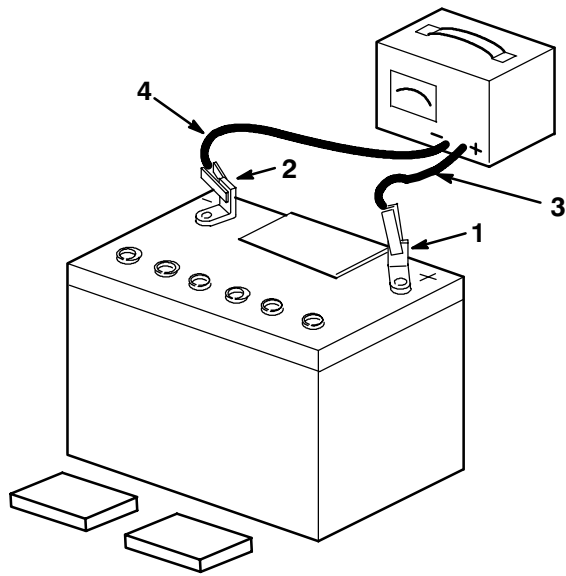

1254

**Figure 5**

- |                  |                           |
|------------------|---------------------------|
| 1. Positive post | 3. Charger red (+) wire   |
| 2. Negative post | 4. Charger black (-) wire |

! **Warning** !

**Charging battery produces gasses that can explode and cause serious injury.**

- **Keep cigarettes, sparks and flames away from battery.**
- **Make sure the ignition switch is off.**
- **Ventilate when charging or using battery in an enclosed space.**

4. When the battery is fully charged, disconnect the charger from the electrical outlet then from the negative and positive battery posts (Fig. 5).
5. Slowly pour electrolyte into each cell until the level is up to the lower part of the tube (Fig. 4) and install covers.
6. Install the battery into the holder.

## Install the Battery

**Important** Activate battery with electrolyte and charge before installing.

1. Mount battery on battery support with terminal posts toward gas tank (Fig. 6).
2. Secure battery with clamp, support rod and wing nut (Fig. 6).

**Note:** Do Not Over tighten.

3. Slide the red terminal boot onto the red battery cable (Fig. 6).
4. Install the positive battery cable to positive (+) battery terminal and the negative battery cable to the negative (-) battery terminal and secure with carriage bolts and lock nuts (Fig. 6).

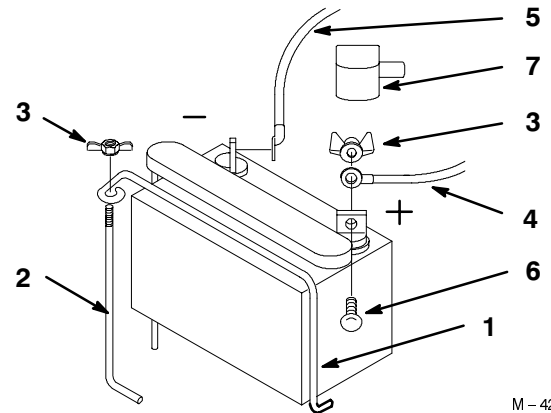

M-4282

**Figure 6**

- |                           |                           |
|---------------------------|---------------------------|
| 1. Clamp                  | 5. Negative battery cable |
| 2. Support rod            | 6. Carriage Bolt          |
| 3. Wing nut               | 7. Terminal Boot          |
| 4. Positive battery cable |                           |

## Check Engine Oil

The engine is shipped with 4 pints of oil in the crankcase; however, oil level must be checked before and after the engine is first started. Check oil level; refer to Checking Oil Level, page 22.

## Check Hydraulic System Fluid

The hydraulic system is shipped with approximately 5 quarts of 10W-30 engine oil; however, oil level must be checked before the engine is first started. Check oil level; refer to Check Hydraulic System Fluid, page 30.

## Operation

**Note:** Determine the left and right sides of the machine from the normal operating position.

## Think Safety First

Please carefully read all the safety instructions and decals in the safety section. Knowing this information could help you, your family, pets or bystanders avoid injury.

Become familiar with all the controls before you start the engine and operate the machine.

The use of protective equipment, such as but not limited to, for eyes, ears, feet and head is recommended.

Caution

**This machine produces sound levels in excess of 85dBA at the operator's ear and can cause hearing loss through extended periods of exposure.**

**Wear hearing protection when operating this machine.**

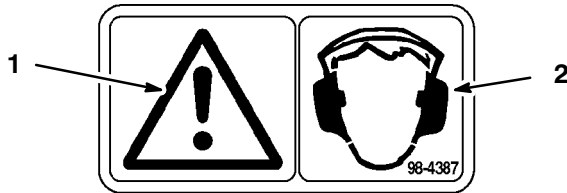

Figure 7

1. Caution                      2. Wear hearing protection

## Starting and Stopping the Engine

### Starting

1. Make sure spark plug wire(s) are installed on spark plug(s).
2. Move the traction pedal to neutral, set the parking brake and move the PTO switch to "OFF."
3. Move the choke control to the "CHOKE" position before starting a cold engine.

**Note:** A warm or hot engine may not require any choking.

4. Rotate ignition key to "START." When engine starts, release key, gradually move choke to run and regulate throttle to desired speed.

**Important** To prevent overheating of the starter motor, do not engage starter longer than 10 seconds. After 10 seconds of continuous cranking, wait 60 seconds before engaging starter motor again.

### Stopping

1. Move the throttle lever to "SLOW" (Fig. 8).

**Note:** If the engine has been working hard or is hot, let it idle for a minute before turning the ignition key "OFF." This helps cool the engine before it is stopped. In an emergency, the engine may be stopped by turning the ignition key to "OFF."

2. Turn the ignition key to "OFF" (Fig. 8).
3. Set the parking brake.
4. Pull wire off spark plug(s) to prevent possibility of accidental starting before storing machine.

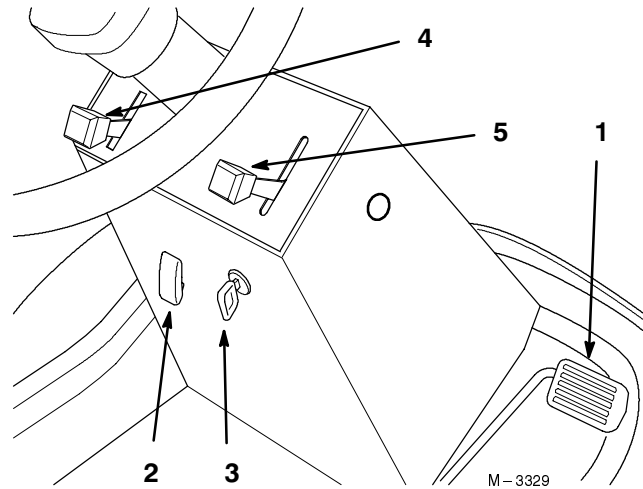

Figure 8

- |                    |             |
|--------------------|-------------|
| 1. Traction pedal  | 4. Choke    |
| 2. PTO switch      | 5. Throttle |
| 3. Ignition switch |             |

## Operating the Power Take Off (PTO)

The power take off (PTO) switch engages and disengages power to the electric clutch.

### Engaging the PTO

1. Release pressure on the traction pedal to stop movement. (Fig. 9).
2. To engage lift cover and move the PTO switch to the "ON" position (Fig. 9).

### Disengaging the PTO

1. Closing the cover moves the PTO switch to the "OFF" position (Fig. 9).

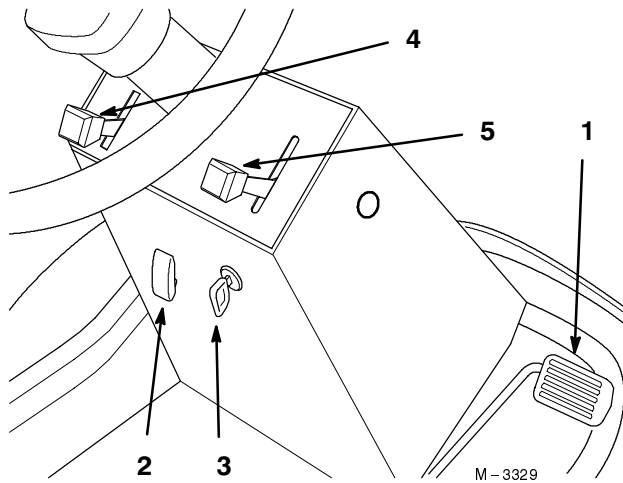

**Figure 9**

- |                    |             |
|--------------------|-------------|
| 1. Traction pedal  | 4. Choke    |
| 2. PTO switch      | 5. Throttle |
| 3. Ignition switch |             |

## Driving Forward or Backward

The throttle control regulates the engine speed as measured in rpm (revolutions per minute). Move the throttle control to the “FAST” position for best performance.

### Forward

1. To go forward, place your foot on the traction pedal (Fig. 9).
2. Release the parking brake.
3. Slowly press on the upper pad of the traction pedal to move forward (Fig. 9).

### Backward

1. To go backward, place your foot on the traction pedal (Fig. 9).
2. Release the parking brake.
3. Slowly press on the lower pad of the traction pedal to move rearward (Fig. 9).

## Stopping the Machine

To stop the machine, release pressure on the traction pedal, move the PTO switch to “OFF” and turn the ignition key to “OFF” to stop the engine and remove the key. Also set the parking brake if you leave the machine unattended; refer to Setting the Parking Brake, page 17.

⚠
**Caution**
⚠

**Children or bystanders may be injured if they move or attempt to operate the tractor while it is unattended.**

**Always remove the ignition and set the parking brake when leaving the machine unattended, even if just for a few minutes.**

## Parking Brake

Always set the parking brake when you stop the machine or leave it unattended.

### Setting the Parking Brake

1. Release pressure on the traction pedal to stop movement.
2. Lift the parking brake lever up to apply the parking brake (Fig. 10).

### Releasing the Parking Brake

1. Move the parking brake lever down to the released the parking brake (Fig. 10).

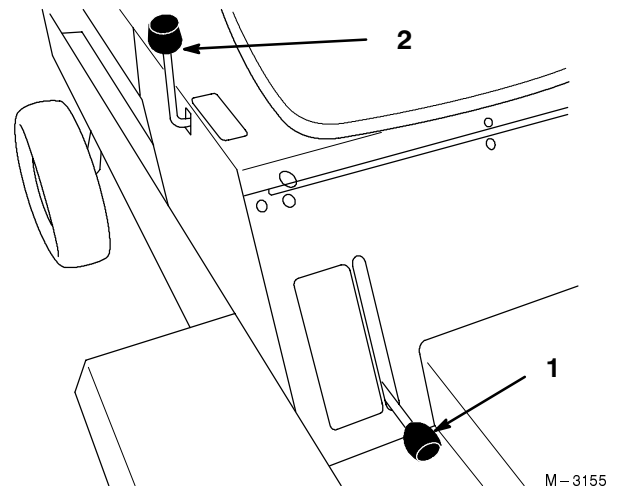

**Figure 10**

- |                  |                         |
|------------------|-------------------------|
| 1. Parking brake | 2. Implement lift lever |
|------------------|-------------------------|

## Implement Lift Lever

The implement lift lever is used to raise and lower various attachments (Fig. 10).

**Note:** When done using implement engage lock bracket and tighten knob.

## Raising Attachments

1. Remove pressure from traction pedal to stop the machine.
2. Loosen the lock bracket knob. Move bracket back and tighten knob (Fig. 11).
3. Pull implement lift lever rearward to raise attachment to the desired height (Fig. 10).

## Lowering Attachments

1. Remove pressure from traction pedal to stop the machine.
2. Loosen the lock bracket knob. Move bracket back and tighten knob (Fig. 11).
3. Push implement lift lever forward to lower attachment (Fig. 10).

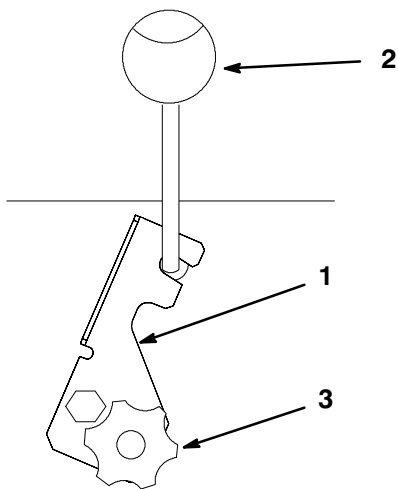

M-4304

**Figure 11**

1. Lock Bracket
2. Implement lift lever
3. Knob

## The Safety Interlock System



### Caution



**If safety interlock switches are disconnected or damaged the machine could operate unexpectedly causing personal injury.**

- **Do not tamper with the interlock switches.**
- **Check the operation of the interlock switches daily and replace any damaged switches before operating the machine.**

## Understanding the Safety Interlock System

The safety interlock system is designed to prevent the engine from rotating or starting unless:

- The traction pedal is in neutral
- The power take off (PTO) is disengaged

The safety interlock system is designed to stop the engine if you rise from the seat when the power take off (PTO) is engaged or the motion control is not in neutral.

## Testing the Safety Interlock System

Test the safety interlock system before you use the machine each time. If the safety system does not operate as described below, have an Authorized Service Dealer repair the safety system immediately.

1. Switch the power take off (PTO) "ON". Now turn the key to "START"; the engine should not rotate.
2. Turn the power take off (PTO) "OFF" and move the motion control (forward or reverse). Now turn the ignition key to "START"; the engine should not rotate.
3. Set the parking brake, move the power take off (PTO) to disengaged, motion control to neutral and start the engine. While the engine is running, engage the power take off (PTO) and rise slightly from the seat; the engine should stop.
4. Set the parking brake, move the power take off (PTO) to disengaged, motion control to neutral and start the engine. While the engine is running, slowly move the motion control (forward or reverse); the engine should stop.

**Important** The unit can be started when all controls are in a safe position, without the operator in the seat, for servicing.

## Positioning the Seat

The seat can move forward and backward. Position the seat where you have the best control of the machine and are most comfortable.

1. To adjust the seat move lever on left side of seat rearward (Fig. 12).
2. Slide seat to desired position and release lever to lock seat into position.

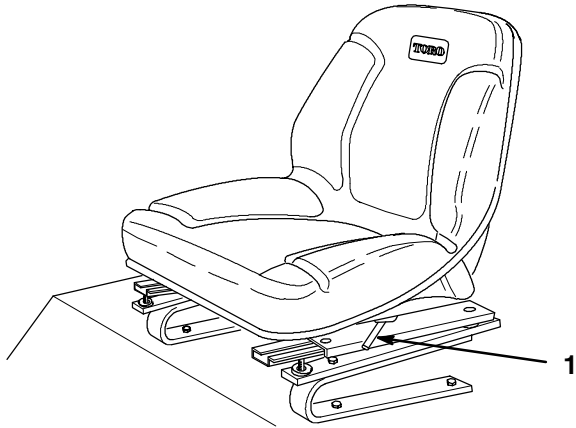

M-4283

**Figure 12**

1. Seat adjustment lever
- 

## Pushing or Towing the Machine

In an emergency, the traction unit can be pushed or towed for a very short distance. Toro does not recommend this as standard procedure.

**Important** Do not push or tow the traction unit faster than 2 to 3 mph because transmission may be damaged. If traction unit must be moved a considerable distance, transport on a truck or trailer.

1. To push or tow forward, the traction pedal must be fully depressed forward.
2. To push or tow in reverse, the traction pedal must be fully depressed in reverse.

# Maintenance



**Note:** Determine the left and right sides of the machine from the normal operating position.

## Recommended Maintenance Schedule

Maintenance Service Interval	Maintenance Procedure
After first 5 Hours	<ul style="list-style-type: none"> <li>• Oil—change</li> </ul>
Each Use	<ul style="list-style-type: none"> <li>• Oil—check level</li> <li>• Safety System—check</li> <li>• Brake—check</li> <li>• Engine—clean outside and cooling fins</li> </ul>
5 hours	<ul style="list-style-type: none"> <li>• Brake—check</li> </ul>
25 hours	<ul style="list-style-type: none"> <li>• Bearings and Bushings—grease<sup>1</sup></li> <li>• Foam Air Cleaner—clean<sup>1</sup></li> <li>• Paper Air Cleaner—clean<sup>1</sup></li> </ul>
50 hours	<ul style="list-style-type: none"> <li>• Oil—change<sup>1</sup></li> <li>• Belts—check for wear/cracks</li> <li>• Tires—check pressure</li> <li>• Battery—check electrolyte level</li> </ul>
100 hours	<ul style="list-style-type: none"> <li>• Oil Filter—change<sup>1</sup> (Every other oil change)</li> <li>• Engine—clean outside and cooling fins</li> <li>• Paper Air Cleaner—replace<sup>1</sup></li> <li>• Fuel Filter—replace</li> </ul>
200 hours	<ul style="list-style-type: none"> <li>• Spark Plug(s)—check</li> </ul>
250 hours	<ul style="list-style-type: none"> <li>• Hydraulic System—change oil</li> <li>• Hydraulic System—change filter</li> </ul>
500 hours	<ul style="list-style-type: none"> <li>• Front Axle—change oil</li> </ul>
At Storage	<ul style="list-style-type: none"> <li>• Chipped Surfaces—paint</li> <li>• Perform all maintenance procedures listed above before storage</li> </ul>

<sup>1</sup>More often in dusty, dirty conditions

**Important** Refer to your engine operator's manual for additional maintenance procedures.

 <span style="font-size: 1.2em; font-weight: bold; margin: 0 20px;">Caution</span> 
<p><b>If you leave the key in the ignition switch, someone could accidentally start the engine and seriously injure you or other bystanders.</b></p> <p><b>Remove the key from the ignition and disconnect the wire from the spark plug(s) before you do any maintenance. Set the wire aside so that it does not accidentally contact the spark plug.</b></p>

## Belt Guard

You will have to remove the belt guard to perform maintenance under seat and engine cover.

### Removing Belt Guard

1. Raise seat and remove center bolt (Fig. 13).
2. Remove guard from interlock rear lip in rear of opening (Fig. 13).
3. Lift guard out (Fig. 13).

### Installing Belt Guard

1. Raise seat.
2. Interlock rear lip of belt guard into rear of opening (Fig. 13).
3. Secure center bolt into speed nut and belt guard (Fig. 13).

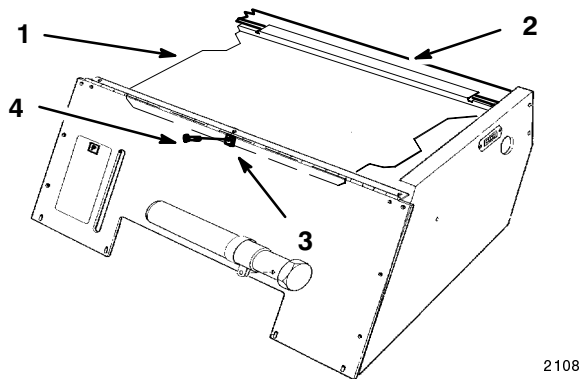

Figure 13

- |               |   |
|---------------|---|
| 1. Belt guard | 4. Center Bolt 1/4-20 x 7/8"<br>(22 mm) |
| 2. Rear lip   |   |
| 3. Speed nut  |   |

## Air Cleaner Service

Foam Element: Clean and re-oil after every 25 operating hours.

Paper Element: Replace after every 100 operating hours.

**Note:** Service the air cleaner more frequently (every few hours) if operating conditions are extremely dusty or sandy.

### Removing the Foam and Paper Elements

1. Raise seat and remove belt guard. See Removing Belt Guard on page 21.

2. Disengage the power take off (PTO), set the parking brake, and turn the ignition key to "OFF" to stop the engine. Remove the key.
3. Clean around the air cleaner to prevent dirt from getting into the engine and causing damage. Unscrew the knob and remove the air cleaner cover (Fig. 14).

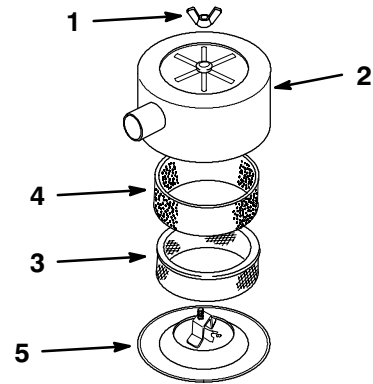

Figure 14

- |             |                |
|-------------|----------------|
| 1. Wing nut | 4. Pre-filter  |
| 2. Cover    | 5. Filter Base |
| 3. Filter   |                |

4. Carefully slide the foam element off the paper element (Fig. 14).
5. Unscrew the cover nut and remove the cover and paper element (Fig. 14).

### Cleaning the Foam and Paper Elements

#### 1. Foam Element

- A. Wash the foam element in liquid soap and warm water. When the element is clean, rinse it thoroughly.
- B. Dry the element by squeezing it in a clean cloth (do not wring).
- C. Put one or two ounces of oil on the element (Fig. 15). Squeeze the element to distribute the oil.

**Important** Replace the foam element if it is torn or worn.

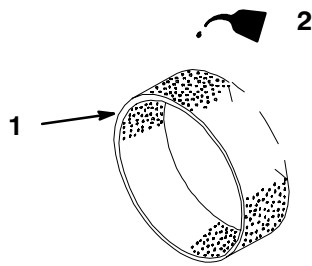

m-1213

**Figure 15**

1. Foam element                      2. Oil

**2. Paper Element**

- A. Lightly tap the element on a flat surface to remove dust and dirt (Fig. 16).
- B. Inspect the element for tears, an oily film, and damage to the rubber seal.

**Important** Never clean the paper element with pressurized air or liquids, such as solvent, gas, or kerosene. Replace the paper element if it is damaged, or cannot be cleaned thoroughly.

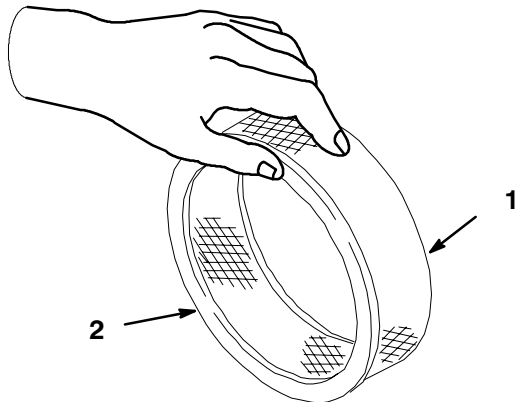

m-1213

**Figure 16**

1. Paper element                      2. Rubber seal

**Installing the Foam and Paper Elements**

**1. Installing the Foam and Paper Elements**

**Important** To prevent engine damage, always operate the engine with the complete foam and paper air cleaner assembly installed.

1. Carefully slide the foam element onto the paper air cleaner element (Fig. 14).
2. Place the air cleaner assembly onto the air cleaner base (Fig. 14).
3. Install the air cleaner cover and secure with cover nut (Fig. 14).

4. Reinstall belt guard. See Installing Belt Guard on page 21.

**Engine Oil Service**

**Service Interval/Specification**

Change oil:

- After the first 8 operating hours.
- After every 50 operating hours.

**Note:** Change oil more frequently when operating conditions are extremely dusty or sandy.

Oil Type: Detergent oil (API service SF, SE/CC, CD or SE)

Crankcase Capacity: w/filter, 1.9 l (4 pints)

Viscosity: See table below

**USE THESE SAE VISCOSITY OILS**

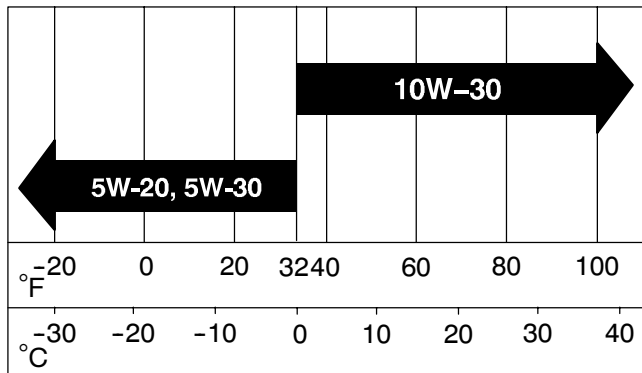

**Checking Oil Level**

1. Raise seat and remove belt guard. See Removing Belt Guard on page 21.
2. Park the machine on a level surface, disengage the power take off (PTO), set the parking brake, and turn the ignition key to “OFF” to stop the engine. Remove the key.
3. Clean around the oil dipstick and oil fill (Fig. 17) so dirt cannot fall into the filler hole and damage the engine.
4. Pull the oil dipstick out and wipe the metal end clean (Fig. 17).
5. Slide the oil dipstick fully into the dipstick tube (Fig. 17). Pull the dipstick out and look at the metal end. If oil level is low, slowly pour only enough oil into the filler hole to raise the level to the “FULL” mark.

**Important** Do not overfill the crankcase with oil because the engine may be damaged.

- Reinstall belt guard. See Installing Belt Guard on page 21.

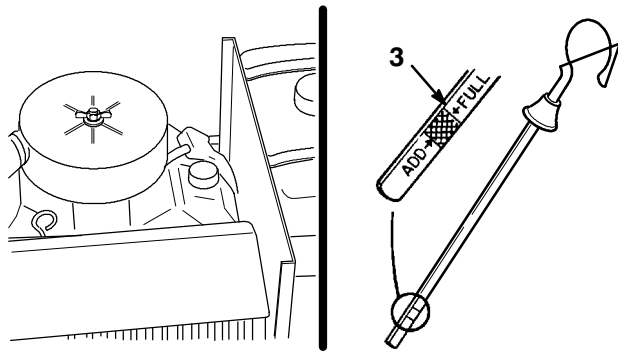

**Figure 17**

- Oil dipstick
- Oil fill
- Metal end

## Changing/Draining Oil

- Start the engine and let it run five minutes. This warms the oil so it drains better.
- Park the machine so that the drain side is slightly lower than the opposite side to assure the oil drains completely. Then disengage the power take off (PTO), set the parking brake, and turn the ignition key to "OFF" to stop the engine. Remove the key.
- Place a pan below the oil drain. Remove the oil drain plug (Fig. 18).
- When oil has drained completely, install the oil drain plug.

**Note:** Dispose of the used oil at a certified recycling center.

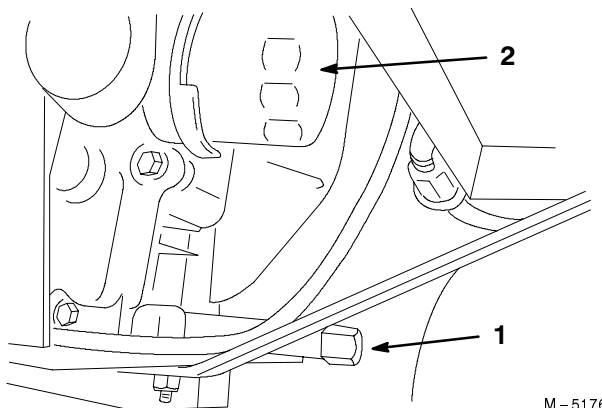

**Figure 18**

- Oil drain plug
- Oil filter

- Slowly pour approximately 80% of the specified amount of oil into the filler tube (Fig. 17). Now check the oil level; refer to Checking Oil Level, page 23. Slowly add additional oil to bring to "FULL" mark on dipstick.

## Change Oil Filter

### Service Interval/Specification

Replace the oil filter every 100 hours or every other oil change.

**Note:** Change oil filter more frequently when operating conditions are extremely dusty or sandy.

- Drain the oil from the engine; refer to Changing/Draining Oil, page 23.
- Remove the old filter and wipe the filter adapter (Fig. 18 and 19) gasket surface.
- Apply a thin coat of new oil to the rubber gasket on the replacement filter (Fig. 19).

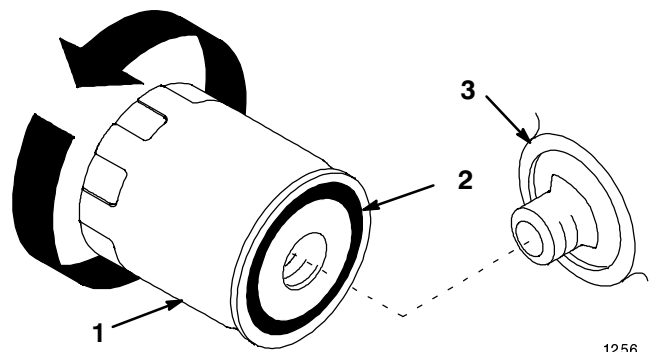

**Figure 19**

- Oil filter
- Gasket
- Adapter

- Install the replacement oil filter to the filter adapter. Turn the oil filter clockwise until the rubber gasket contacts the filter adapter, then tighten the filter an additional 1/2 turn (Fig. 19).
- Fill the crankcase with the proper type of new oil; refer to Changing/Draining Oil, page 23.

## Spark Plug

### Service Interval/Specification

Check the spark plug(s) after every 200 operating hours. Make sure the air gap between the center and side electrodes is correct before installing the spark plug. Use a spark plug wrench for removing and installing the spark plug(s) and a gapping tool/feeler gauge to check and adjust the air gap. Install a new spark plug(s) if necessary.

Type: Champion RC 12YC (or equivalent)  
Air Gap: 0.040 in. (1 mm)

## Removing the Spark Plug(s)

1. Disengage the power take off (PTO), set the parking brake, and turn the ignition key to "OFF" to stop the engine. Remove the key.
2. Raise seat and remove belt guard. See Removing Belt Guard on page 21.
3. To gain access to the rear spark plug the gas tank must be removed (Fig. 20).

**Danger**

**In certain conditions, gasoline is extremely flammable and highly explosive. A fire or explosion from gasoline can burn you and others and can damage property.**

- Drain gasoline from the fuel tank when the engine is cold. Do this outdoors in an open area. Wipe up any gasoline that spills.
- Never smoke when draining gasoline, and stay away from an open flame or where a spark may ignite the gasoline fumes.

4. Rotate tank and set in hood to prevent fuel spilling.
5. Push out plastic cover from access hole in plate between engine and gas tank.
6. Pull the wire(s) off the spark plug(s). Now clean around the spark plug(s) to prevent dirt from falling into the engine and potentially causing damage.
7. Remove the spark plug(s) and metal washer.

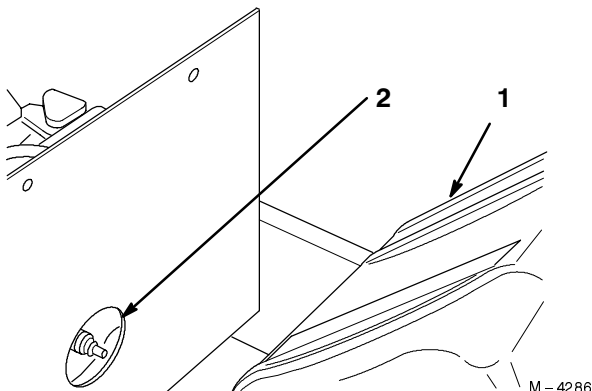

Figure 20

1. Fuel tank
2. Opening for access

## Checking the Spark Plug

1. Look at the center of the spark plug(s) (Fig. 21). If you see light brown or gray on the insulator, the engine is operating properly. A black coating on the insulator usually means the air cleaner is dirty.

**Important** Never clean the spark plug(s). Always replace the spark plug(s) when it has: a black coating, worn electrodes, an oily film, or cracks.

2. Check the gap between the center and side electrodes (Fig. 21). Bend the side electrode (Fig. 21) if the gap is not correct.

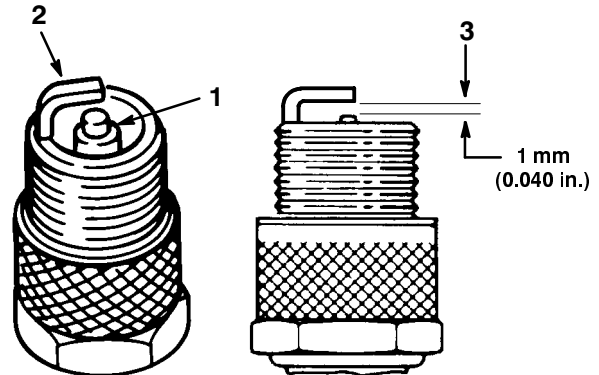

Figure 21

1. Center electrode insulator
2. Side electrode
3. Air gap (not to scale)

## Installing the Spark Plug(s)

1. Install the spark plug(s) and metal washer. Make sure the air gap is set correctly.
2. Tighten the spark plug(s) to 17 N m (12 ft. lb).
3. Push the wire(s) onto the spark plug(s) (Fig. 20).
4. Push plastic cover into access hole in plate between engine and gas tank.
5. Lift fuel tank and attach fuel hose, secure with hose clamp.
6. Rotate fuel tank into position, hook straps into lower bracket and secure with capscrews and lock nuts.
7. Reinstall belt guard. See Installing Belt Guard on page 21.

## Greasing and Lubrication

### Service Interval/Specification

Grease all bearings and bushings every 25 operating hours. Grease more frequently (daily) when operating conditions are extremely dusty or sandy.

Grease Type: General-purpose lithium base grease.

## How to Grease

1. Disengage the power take off (PTO), set the parking brake, and turn the ignition key to “OFF” to stop the engine. Remove the key.
2. Clean the grease fittings with a rag. Make sure to scrape any paint off the front of the fitting(s).
3. Connect a grease gun to the fitting. Pump grease into the fittings until grease begins to ooze out of the bearings.
4. Wipe up any excess grease.

## Where to Add Grease

1. Lubricate the wheel bearings (Fig. 22).

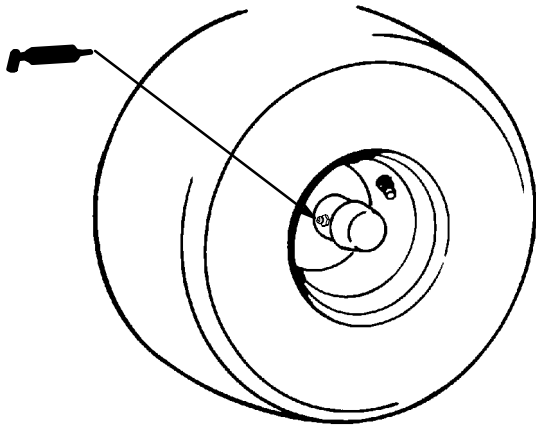

M-4287

Figure 22

2. Lubricate spindles, steering shaft and pivot (Fig. 23).

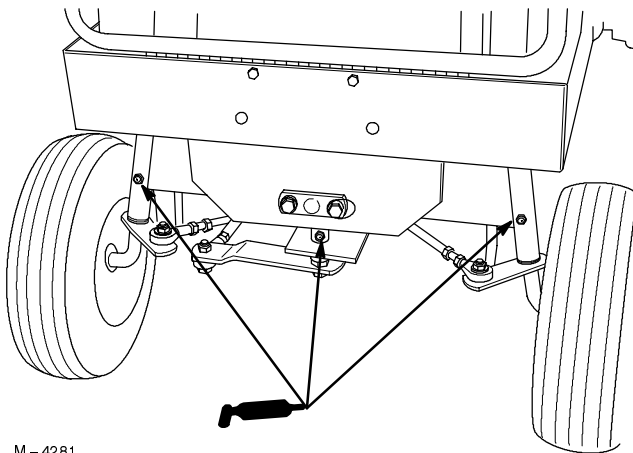

M-4281

Figure 23

3. Lubricate the axle bearings (Fig. 24).

Once a year, grease front wheel hub to prevent the formation of rust and to simplify future wheel removal.

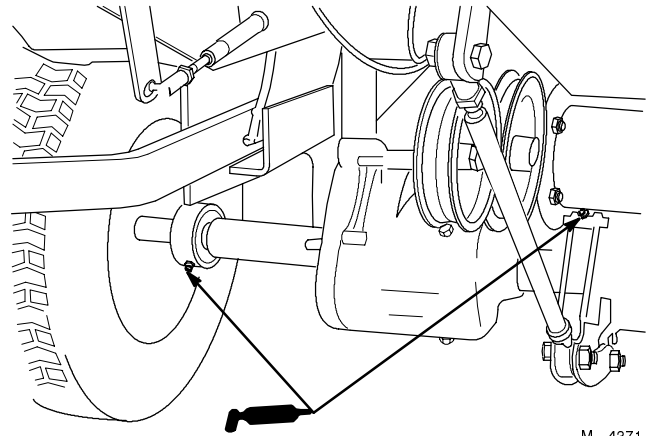

M-4371

Figure 24

4. Lubricate the traction pedal bushings with a few drops of SAE 10W-30 oil or dry spray lube and the steering shaft (Fig. 25).

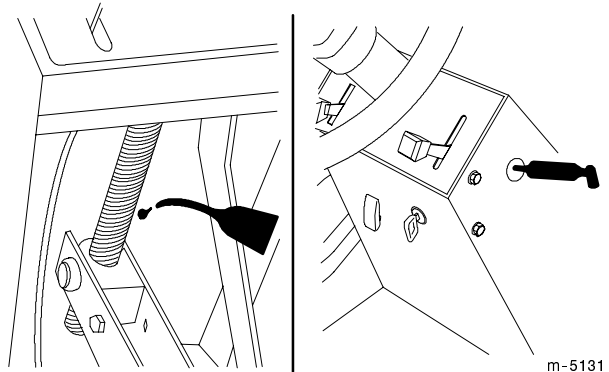

m-5131

Figure 25

## Brake

Always set the parking brake when you stop the machine or leave it unattended. If the parking brake does not hold securely, an adjustment is required.

### Checking the Brake

1. Park the machine on a level surface, disengage the power take off (PTO), set the parking brake, and turn the ignition key to “OFF” to stop the engine. Remove the key.
2. Drive wheels must lock when the brake is applied. Adjustment is required if the wheels turn and do not lock; refer to Adjusting the Brake, page 26.
3. Release the brake, wheels should rotate freely.
4. If both conditions are met no adjustment is required.

**Important** With the parking brake released, the drive wheels must rotate freely. If brake action and free wheel rotation cannot be achieved contact your service dealer immediately.

## Adjust the Brake

If drive wheels do not rotate freely when brake lever is in the OFF position, or brake does not hold when lever is in the ON position, an adjustment is required.

1. Move brake lever to the ON position.
2. Measure distance between disc brake actuating arm and stop pin on axle bracket assembly (Fig. 26). Distance should be less than 1/4 inch (6 mm).
3. If distance is greater than 1/4 inch (6 mm), tighten locknut to decrease distance between actuating arm and stop pin (Fig. 26).
4. With the brake lever OFF, check clearance between brake pads and disc with a feeler gauge (Fig. 26). Proper clearance is approximately .010 inch (.25 mm).
5. The actuating arm should be no more than 3/8 inch (10 mm) away from stop with brake lever in the ON position.
6. Check the brake operation again; refer to Checking the Brake, page 25.
7. Check adjustment. Drive wheels should rotate freely when brake lever is in the OFF position.

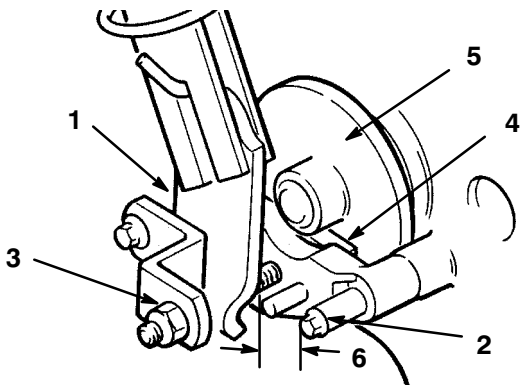

Figure 26

- |                        |                   |
|------------------------|-------------------|
| 1. Brake actuating arm | 4. Brake pad (2)  |
| 2. Stop pin            | 5. Disc           |
| 3. Lock nut            | 6. 1/4 inch (6mm) |

2183

## Fuel Filter

### Service Interval/Specification

Replace the fuel filter after every 100 operating hours or yearly, whichever occurs first.

### Replacing the Fuel Filter

Never install a dirty filter if it is removed from the fuel line.

1. Disengage the power take off (PTO), set the parking brake, and turn the ignition key to "OFF" to stop the engine. Remove the key.
2. Have a container ready to drain fuel from the tank. It is best to change fuel filter when fuel tank is almost empty.
3. Loosen hose clamps and slide them up the hose, away from the filter (Fig. 27).
4. Remove the filter from the fuel lines (Fig. 27).
5. Install a new filter, if the filter has an arrow, install with arrow pointing toward the carburetor.
6. Move the hose clamps close to the filter and tighten.

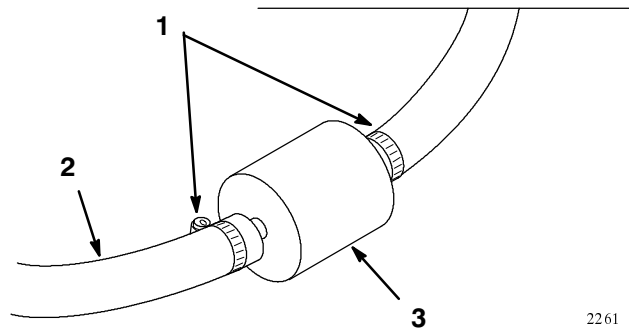

2261

Figure 27

- |               |           |
|---------------|-----------|
| 1. Hose clamp | 3. Filter |
| 2. Fuel line  |           |

## Tire Pressure

### Service Interval/Specification

Maintain the air pressure in the front and rear tires as specified. Check the pressure at the valve stem after every 50 operating hours or monthly, whichever occurs first (Fig. 28). Check the tires when they are cold to get the most accurate pressure reading.

Pressure: 103 kPa (15 psi) front and rear

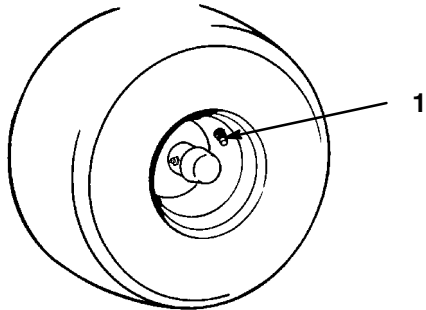

M-4287

**Figure 28**

1. Valve stem

## Cleaning the Cooling System

### Service Interval/Specification

Before each use, remove grass clippings, dirt and grime from the entire machine, muffler and engine air intake screen. Every 100 operating hours clean dirt and chaff from the engine cylinder head fins and blower housing. This will help insure adequate cooling and reduce the possibility of overheating and mechanical damage to the engine.

1. Raise seat and remove belt guard. See Removing Belt Guard on page 21.
2. Open hood and pull spark plug wire(s) off.
3. To avoid overheating and possible engine damage clean, grass, dust, dirt and oil from outside of engine, air intake screen and muffler.
4. To clean cylinder head fins, remove engine from chassis and remove cooling shrouds. Make sure cooling shrouds are re-installed before operating engine.
5. Reinstall belt guard. See Installing Belt Guard on page 21.

## Adjust Belts

If belt slippage occurs, idler pulleys must be adjusted to increase belt tension.

1. Disengage the power take off (PTO), set the parking brake, and turn the ignition key to "OFF" to stop the engine. Remove the key.
2. Raise seat and remove belt guard. See Removing Belt Guard on page 21.

3. Measure distance from bottom of spacer on pulley mounting screw to bottom of slot in idler adjustment link. Distance should be 1/4 inch (6 mm) or less (Fig. 29).
4. To adjust, remove cotter hair pin and washer securing to mounting pin (Fig. 29).
5. Slide tension bracket off mounting pin. Adjust and select new hole until bottom of spacer is within 1/4 inch from bottom of slot (Fig. 29).
6. Secure tension bracket with washer and cotter pin (Fig. 29).
7. Reinstall belt guard. See Installing Belt Guard on page 21.

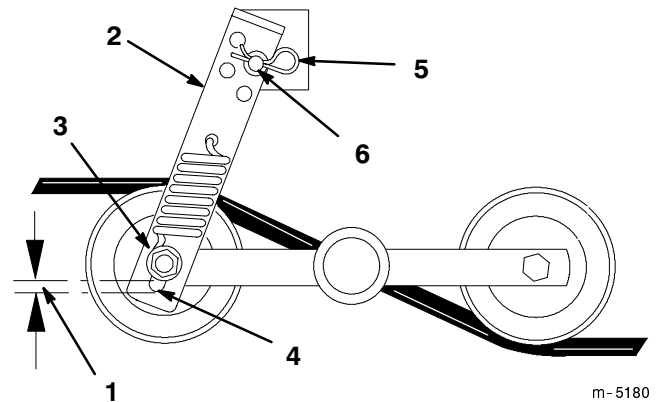

m-5180

**Figure 29**

1. 1/4 in. (6 mm) space
2. Tension bracket
3. Pulley mounting screw
4. Bottom of slot
5. Hair pin cotter
6. Mounting pin

## Replace Belts

To replace traction or jackshaft belt, use the following procedures and belt routing diagram (Fig. 30).

1. Disengage the power take off (PTO), set the parking brake, and turn the ignition key to "OFF" to stop the engine. Remove the key.
2. Raise seat and remove belt guard. See Removing Belt Guard on page 21.
3. Clutch anchor bolt must be removed, and clutch unplugged from wire harness before traction belts can be removed.
4. Release tension in idler pulleys before removing or installing belts (Fig. 29).
5. Install belts, route traction belt over transmission as shown (Fig. 30).
6. Install clutch anchor bolt and plug in connector.

**Important** To avoid damage reinstall clutch anchor bolt before connecting wire.

7. Adjust belt tension; refer to Adjust Belts page 27.
8. Reinstall belt guard. See Installing Belt Guard on page 21.

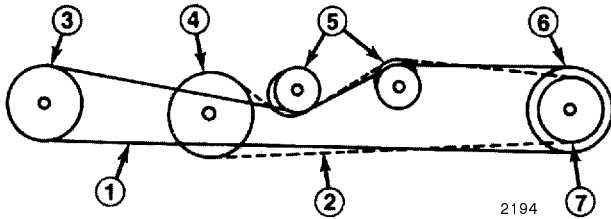

**Figure 30**

- |                        |                  |
|------------------------|------------------|
| 1. Jackshaft belt      | 5. Idler pulley  |
| 2. Traction belt       | 6. Clutch pulley |
| 3. Jackshaft pulley    | 7. Engine pulley |
| 4. transmission pulley |                  |

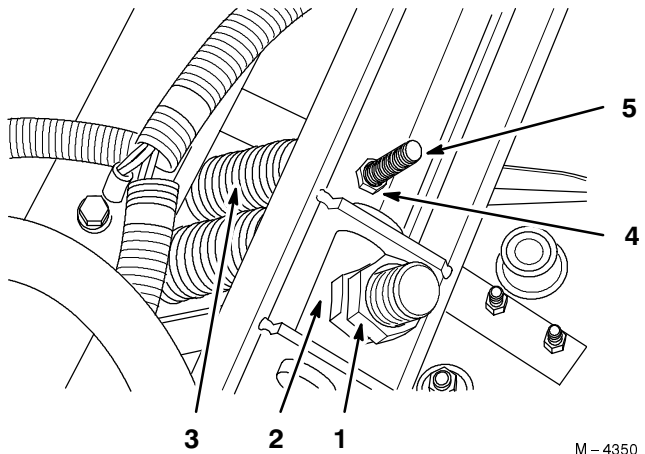

**Figure 31**

- |                          |                      |
|--------------------------|----------------------|
| 1. Jam nut               | 4. Adjustment nut    |
| 2. Cylinder pivot pin    | 5. Lift arm "T" hook |
| 3. Counterbalance spring |                      |

## Adjust Lift Cylinder and Counterbalance Springs

1. Raise seat and remove belt guard. See Removing Belt Guard on page 21.
2. Start engine and lower lift arms (cutting unit) until lift cylinder is fully extended and lift (cutting unit) is fully lowered.
3. Measure distance between cylinder jam nuts and cylinder pivot pin (Fig. 31). Distance should be approximately 2-1/4 inch.
4. Loosen jam nuts and adjust, if necessary, to attain needed clearance.

5. Start engine and raise lift arms (cutting unit) until lift cylinder is fully retracted and lift (cutting unit) is fully raised.
6. Check distance between clevis pin and bottom hooks of springs (Fig. 29). Distance should be 1/4 inch or less.
7. Adjust nut on lift arm "T" hook to obtain required distance.
8. Reinstall belt guard. See Installing Belt Guard on page 21.

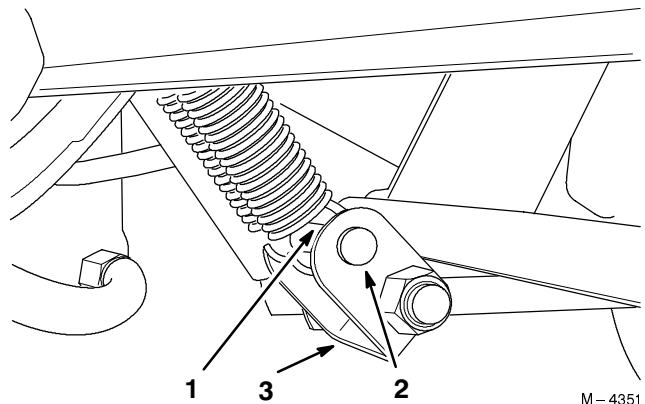

**Figure 32**

- |                              |                 |
|------------------------------|-----------------|
| 1. 1/4 inch (6 mm) clearance | 3. Lift bracket |
| 2. Clevis pin & cotter pin   |                 |

## Adjust Transmission Neutral

The machine must not creep when traction pedal is released. If it does creep, an adjustment is required.

1. Park machine on a level surface, lower cutting unit and shut engine off. Disengage the PTO and engage the parking brake.
2. Raise seat and remove belt guard. See Removing Belt Guard on page 21.
3. Jack up front of machine until tires are off shop floor. Support machine with jack stands to prevent it from falling accidentally.

**Danger**

**Mechanical or hydraulic jacks may fail to support machine and cause a serious injury.**

- Use jack stand when supporting machine.
- Do not use hydraulic jacks.

4. Loosen lock nut on adjustment cam (Fig. 33).
5. Start engine and rotate adjusting cam in either direction until wheels stop rotating (Fig. 33).

**Warning**

**Engine must be running so transmission neutral adjustment can be performed. Contact with moving parts or hot surfaces may cause personal injury.**

**Keep hands, feet, face, clothing and other body parts away from rotating parts, muffler and other hot surfaces.**

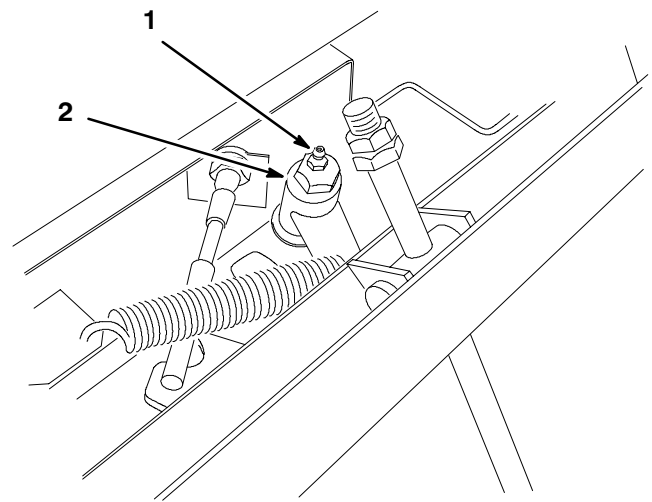

m-5179

**Figure 33**

1. Adjustment cam
  2. Lock nut
- 
6. Stop engine and tighten lock nut to secure adjustment (Fig. 33).
  7. Start engine and check adjustment. Repeat adjustment, if necessary.
  8. Stop engine. Remove jack stands and lower machine to the shop floor. Test drive the machine to be sure it does not creep.
  9. Reinstall belt guard. See Installing Belt Guard on page 21.

## Adjust Electric Clutch

The clutch is adjusted to ensure proper engagement and braking action.

1. Disengage the power take off (PTO), set the parking brake, and turn the ignition key to "OFF" to stop the engine. Remove the key.
2. To adjust clutch, tighten or loosen lock nuts on flange studs (Fig. 34).
3. Check adjustment by inserting feeler gauge thru slots next to studs.
4. The proper disengaged clearance between the clutch plates is 0.30-0.45 mm (.012-.018 in.). It will be necessary to check this clearance at each of the three slots to ensure the plates are parallel to each other.



5. Install the tube assembly and hose assembly to reservoir (Fig. 36).

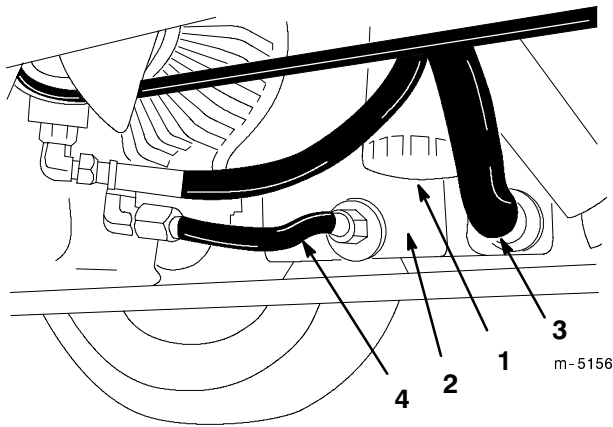

**Figure 36**

- |              |                  |
|--------------|------------------|
| 1. Filter    | 3. Hose assembly |
| 2. Reservoir | 4. Tube assembly |

6. Fill the reservoir to the proper level; refer to Check Hydraulic System Fluid.
7. Place all controls in neutral or disengaged position and start engine. Run engine at lowest possible RPM to purge the system of air.
8. Run engine until lift cylinder extends and retracts and forward and reverse wheel motion is achieved.
9. Stop the engine and check the oil level in reservoir, add oil if necessary.
10. Check all connections for leaks.

## Change Hydraulic Oil Filter

The hydraulic oil filter keeps the hydraulic system relatively free of contaminants. However, the hydraulic oil filter must be serviced at regular intervals. The intervals are: initially, after the first 5 hours of operation, and thereafter every 250 hours of operation or yearly, whichever comes first. Use a genuine TORO oil filter for replacement.

1. Remove hydraulic oil filter from mounting head. Use bottom type filter wrench (Fig. 36). Dispose of filter properly.
2. Apply a film of oil on the gasket. Install filter by hand until gasket contacts mounting head; then tighten filter an additional 3/4 turn.
3. Start engine and check for oil leaks. Allow engine to run for about 2 minutes so any air in system is purged. Then shut engine off.
4. Check level of oil in reservoir; refer to Check Hydraulic System Fluid, page 30.

## Adjust Steering

1. Measure toe-in distance (at axle height) at front and rear of steering tires. Front measurement must be 0-1/4 inch (6 mm) less than rear measurement.
2. Loosening jam nuts and rotating tie rod to adjust clearance (Fig. 37).
3. Turn steering wheel full left to achieve a full left turn (Fig. 37).
4. Check clearance between left tire and tie rod. There should be 1 inch (25 mm)  $\pm$  1/4 inch (6 mm) clearance at this position.
5. Loosening jam nuts and rotating steering rod to adjust clearance (Fig. 37).
6. Rotate tie rod to move front of tire in or out.
7. Tighten jam nuts when adjustment is correct.

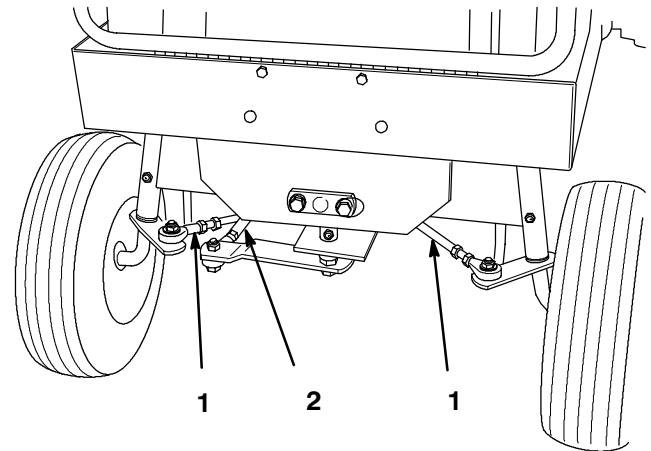

**Figure 37**

- |            |                 |
|------------|-----------------|
| 1. Tie rod | 2. Steering rod |
|------------|-----------------|

# Hydraulic Schematic

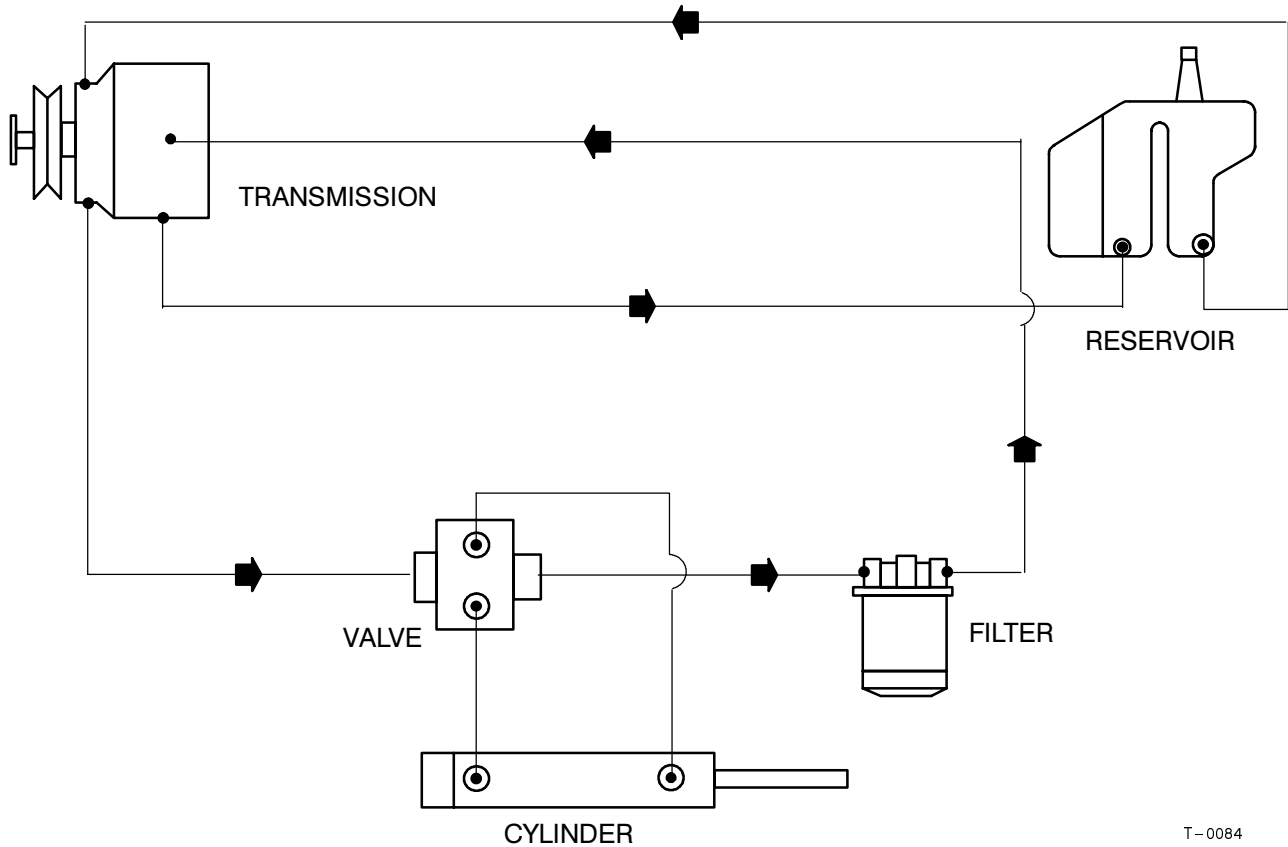

T-0084

## GM 120 QUICK REFERENCE AID



### CHECK/SERVICE

1. OIL LEVELS (ENGINE/TRANS)
2. AXLE OIL
3. TIRE PRESSURE
4. BELT TENSION (TRANS, PTO)
5. FUEL-GAS ONLY
6. BATTERY
7. GREASE, LUBE POINTS
8. ADJUST PARKING BRAKE
9. AIR CLEANER
10. ELECTRIC CLUTCH GAP .012-.018
11. DEBRIS UNDER HOOD & SEAT PLATE & ENGINE COOLING FINS

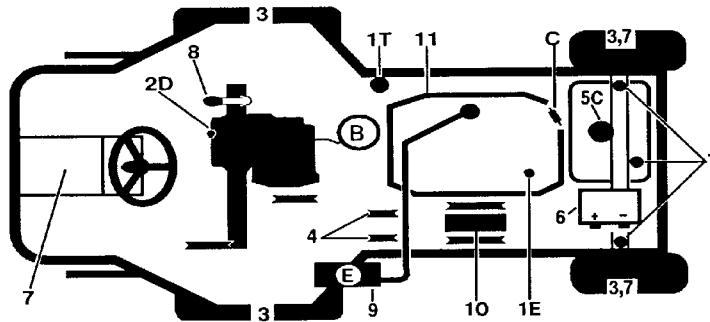

92-6288

### FLUID SPECIFICATION \* SEE OPERATOR'S MANUAL FOR INITIAL CHANGE

A. ENGINE OIL*	TYPE >	TYPE <	CAPACITY	CHANGE INTERVALS	FILTER PART NO.
	SAE 10W-30 OR 10W-40 SF OR SG	SAE 5W-20 OR 5W-30 SF OR SG	1.9L (4PT.)	50 HRS.	FILTER 100 HRS KOHLER 12 050 01
B. TRANS OIL	SAE 10W-30 SF-CC,CD	TYPE F OR FA TRANS FLUID	4.73L (5QT.)	250 HRS.	FILTER 250 HRS 54-0110
C. FUEL	UNLEADED FUEL		18.93L (5GAL.)	---	FILTER 400 HRS 38-8000
D. AXLE OIL	SAE E.R 90 WT.		14.9cl (44oz)	500 HRS	
E. AIR FILTER	STANDARD				33-1300

## Change Front Axle Oil

After every 500 hours of operation, change oil in the front axle.

1. Run machine before changing oil to warm oil. Warm oil flows more freely and carries more contaminants than cold oil.

2. Clean area around drain plug and place a drain pan below drain plug on axle (Fig. 38).
3. Remove drain plug and allow oil to flow into drain pan (Fig. 38). After oil is drained, reinstall drain plug.
4. Remove fill plug and fill to plug level with SAE EP-90 wt. oil (approximately 14.9cl (44 oz.)) (Fig. 38).

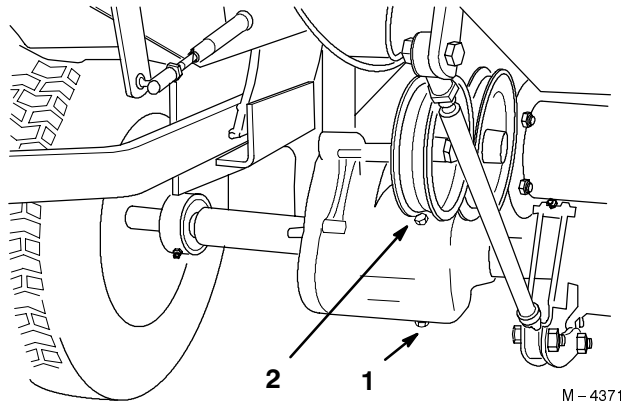

**Figure 38**

1. Drain plug
2. Fill plug

## Battery Service

! **Warning** !

**Battery posts, terminals, and related accessories contain lead and lead compounds, chemicals known to the State of California to cause cancer and reproductive harm. Wash hands after handling.**

### Service Interval/Specification

Check the electrolyte level in the battery every 50 hours. Always keep the battery clean and fully charged. Use a paper towel to clean the battery case. If the battery terminals are corroded, clean them with a solution of four parts water and one part baking soda. Apply a light coating of grease to the battery terminals to prevent corrosion.

Voltage: 12 v, 280 Cold Cranking Amps

### Checking Electrolyte Level

1. Raise seat and remove belt guard. See Removing Belt Guard on page 21.

2. With the engine off, open the covers to see into the cells. The electrolyte must be up to the lower part of the tube (Fig. 39). Do not allow the electrolyte to get below the plates. (Fig. 39).
3. If the electrolyte is low, add the required amount of distilled water; refer to Adding Water to the Battery, page 33.
4. Reinstall belt guard. See Installing Belt Guard on page 21.

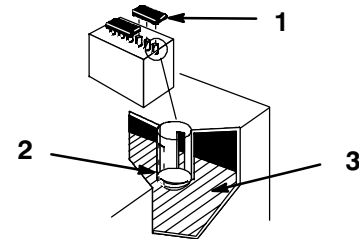

**Figure 39**

1. Filler caps
2. Lower part of tube
3. Plates

### Adding Water to the Battery

The best time to add distilled water to the battery is just before you operate the machine. This lets the water mix thoroughly with the electrolyte solution.

1. Clean the top of the battery with a paper towel.
2. Lift off the filler caps (Fig. 39).
3. Slowly pour distilled water into each battery cell until the level is up to the lower part of the tube (Fig. 39).

**Important** Do not overfill the battery because electrolyte (sulfuric acid) can cause severe corrosion and damage to the chassis.



4. Press the filler caps onto the battery.

### Charging the Battery

**Important** Always keep the battery fully charged (1.260 specific gravity). This is especially important to prevent battery damage when the temperature is below 0°C (32°F).

1. Raise seat and remove belt guard. See Removing Belt Guard on page 21.
2. Remove the battery from the holder.
3. Check the electrolyte level; refer to Checking Electrolyte Level.

4. Remove the filler caps from the battery and connect a 3 to 4 amp battery charger to the battery posts. Charge the battery at a rate of 4 amperes or less for 4 hours (12 volts). Do not overcharge the battery. Install the filler caps after the battery is fully charged.

 <b>Warning</b> 
<p><b>Charging battery produces gasses that can explode and cause serious injury.</b></p> <ul style="list-style-type: none"><li>• <b>Keep cigarettes, sparks and flames away from battery.</b></li><li>• <b>Make sure the ignition switch is off.</b></li><li>• <b>Ventilate when charging or using battery in an enclosed space.</b></li></ul>

5. Install the battery into the holder.
6. Reinstall belt guard. See Installing Belt Guard on page 21.

## Wire Harness Service

Prevent corrosion of wiring terminals by applying Grafo 112X (Skin-over) grease, to the inside of all harness connectors whenever the harness is replaced.

Whenever working with the electrical system, always disconnect battery cables, negative (-) cable first, to prevent possible wiring damage from short-outs.

**Important** Before welding on the machine, disconnect ground cable from the battery to prevent damage to the electrical system.

## Waste Disposal

Engine oil, hydraulic oil and engine coolant are pollutants to the environment. Dispose of these according to your state and local regulations.

## Transporting Machines

Use a heavy-duty trailer or truck to transport the machine. Ensure that the trailer or truck has all necessary lighting and marking as required by law. Please carefully read all the safety instructions and decals in the safety section. Knowing this information could help you, your family, pets or bystanders avoid injury.

To transport the machine:

- Lock brake and block wheels.
- Securely fasten the machine to the trailer or truck with straps, chains, cable, or ropes.
- Secure a trailer to towing vehicle with safety chains.

# Wiring Diagram

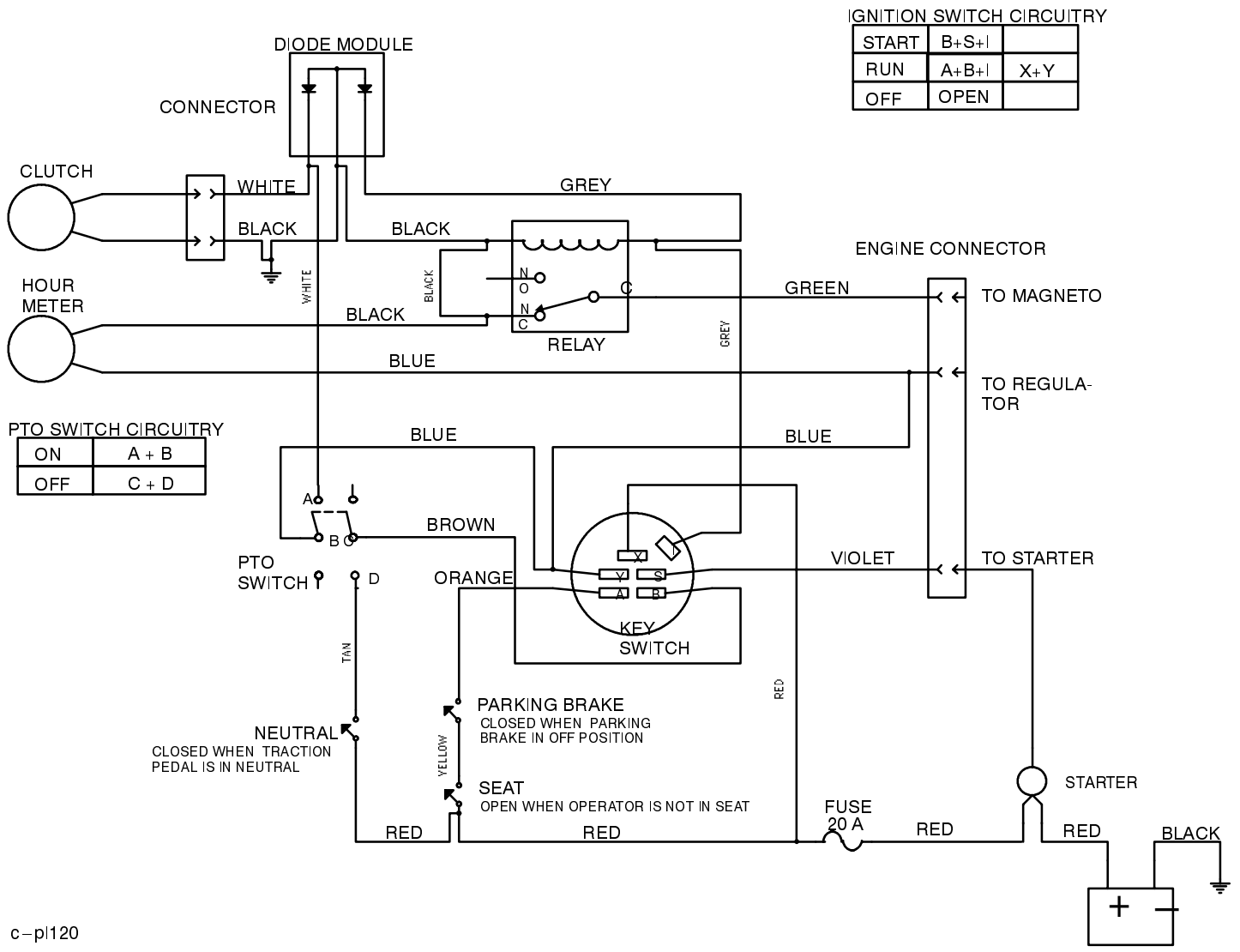

IGNITION SWITCH CIRCUITRY

START	B+S+I	
RUN	A+B+I	X+Y
OFF	OPEN	

PTO SWITCH CIRCUITRY

ON	A + B
OFF	C + D

c-pl120

## Cleaning and Storage

1. Disengage the power take off (PTO), set the parking brake, and turn the ignition key to “OFF” to stop the engine. Remove the key.
  2. Remove grass clippings, dirt, and grime from the external parts of the entire machine, especially the engine. Clean dirt and chaff from the outside of the engine’s cylinder head fins and blower housing.
- Important** You can wash the machine with mild detergent and water. Do not pressure wash the machine. Avoid excessive use of water, especially near the control panel, and engine.
3. Check the brake; refer to Brake, page 25.
  4. Service the air cleaner; refer to Air Cleaner Service, page 21.
  5. Grease the machine; refer to Greasing and Lubrication, page 24.
  6. Change the crankcase oil and filter; refer to Engine Oil, page 22.
  7. Change the hydraulic system oil and filter; refer to Change Hydraulic Oil and Filter, page 30.
  8. Remove the battery from the chassis, check the electrolyte level, and charge fully; refer to Battery, page 33. Do not connect the battery cables to the battery posts during storage.

**Important** The battery must be fully charged to prevent it from freezing and being damaged at temperatures below 0° C (32° F). A fully charged battery maintains its charge for about 50 days at temperatures lower than 4° C (40° F). If temperatures will be above 4° C (40° F), check the electrolyte level in the battery and charge every 30 days.

9. Check the tire pressure; refer to Tire Pressure, page 26.
10. During long-term storage, either drain gasoline from the fuel tank (step 11) or add a fuel stabilizer/conditioner additive to a full tank of gasoline (step A).
11. Drain gasoline from the fuel tank. After fuel is drained, start the engine and let it idle until all gasoline is consumed and the engine stops. This eliminates gum-like buildup in the fuel system, which causes hard starting. Try to start the engine two more times to assure that no gasoline is in the fuel system.
  - A. Add the correct amount of a fuel stabilizer/conditioner to a full tank of gasoline.

**Note:** Stabilizer/conditioners normally preserve gasoline for six to eight months.

12. Remove the spark plug(s) and check its condition; refer to Spark Plug, page 23. With the spark plug(s) removed from the engine, pour two tablespoons of engine oil into the spark plug hole. Now use the starter to crank the engine and distribute the oil inside the cylinder. Install the spark plug(s). Do not install the wire on the spark plug(s).
13. Check and tighten all bolts, nuts, and screws. Repair or replace any part that is damaged or defective.
14. Paint all scratched or bare metal surfaces. Paint is available from your Authorized Service Dealer.
15. Store the machine in a clean, dry garage or storage area. Remove the key from the ignition switch and keep it in a memorable place. Cover the machine to protect it and keep it clean.

## Troubleshooting

PROBLEM	POSSIBLE CAUSES	CORRECTIVE ACTION
Starter does not rotate.	<ol style="list-style-type: none"> <li>1. Power take off (PTO) switch is ENGAGED.</li> <li>2. Traction control pedal is not in neutral.</li> <li>3. Electrical connections are corroded or loose.</li> <li>4. Fuse is blown.</li> <li>5. Battery is dead.</li> <li>6. Solenoid or switch is defective.</li> </ol>	<ol style="list-style-type: none"> <li>1. Move (PTO) switch to DISENGAGED.</li> <li>2. Move traction control pedal to neutral position.</li> <li>3. Check electrical connections for good contact.</li> <li>4. Replace fuse.</li> <li>5. Charge battery.</li> <li>6. Contact Authorized Service Dealer.</li> </ol>

<b>PROBLEM</b>	<b>POSSIBLE CAUSES</b>	<b>CORRECTIVE ACTION</b>
Engine will not start, starts hard, or fails to keep running.	<ol style="list-style-type: none"> <li>1. Operator is not seated.</li> <li>2. Parking brake is OFF.</li> <li>3. Fuel tank is empty.</li> <li>4. Choke is not ON.</li> <li>5. Air cleaner is dirty.</li> <li>6. Spark plug wire is loose or disconnected.</li> <li>7. Spark plug is pitted, fouled, or gap is incorrect.</li> <li>8. Dirt in fuel filter.</li> <li>9. Dirt, water, or stale fuel is in fuel system.</li> </ol>	<ol style="list-style-type: none"> <li>1. Sit on seat.</li> <li>2. Move parking brake to ON.</li> <li>3. Fill fuel tank with gasoline.</li> <li>4. Move choke lever to ON.</li> <li>5. Clean or replace air cleaner element.</li> <li>6. Install wire on spark plug.</li> <li>7. Install new, correctly gapped spark plug.</li> <li>8. Replace fuel filter.</li> <li>9. Contact Authorized Service Dealer.</li> </ol>
Engine loses power.	<ol style="list-style-type: none"> <li>1. Engine load is excessive.</li> <li>2. Air cleaner is dirty.</li> <li>3. Oil level in crankcase is low.</li> <li>4. Cooling fins and air passages under engine blower housing are plugged.</li> <li>5. Spark plug is pitted, fouled, or gap is incorrect.</li> <li>6. Vent hole in fuel cap is plugged.</li> <li>7. Dirt in fuel filter.</li> <li>8. Dirt, water, or stale fuel is in fuel system.</li> </ol>	<ol style="list-style-type: none"> <li>1. Reduce ground speed.</li> <li>2. Clean air cleaner element.</li> <li>3. Add oil to crankcase.</li> <li>4. Remove obstruction from cooling fins and air passages.</li> <li>5. Install new, correctly gapped spark plug.</li> <li>6. Clean or replace the fuel cap.</li> <li>7. Replace fuel filter.</li> <li>8. Contact Authorized Service Dealer.</li> </ol>
Engine overheats.	<ol style="list-style-type: none"> <li>1. Engine load is excessive.</li> <li>2. Oil level in crankcase is low.</li> <li>3. Cooling fins and air passages under engine blower housing are plugged.</li> </ol>	<ol style="list-style-type: none"> <li>1. Reduce ground speed.</li> <li>2. Add oil to crankcase.</li> <li>3. Remove obstruction from cooling fins and air passages.</li> </ol>
Abnormal vibration.	<ol style="list-style-type: none"> <li>1. Engine mounting bolts are loose.</li> <li>2. Loose engine pulley, idler pulley, or blade pulley.</li> <li>3. Engine pulley is damaged.</li> </ol>	<ol style="list-style-type: none"> <li>1. Tighten engine mounting bolts.</li> <li>2. Tighten the appropriate pulley.</li> <li>3. Contact Authorized Service Dealer.</li> </ol>
Machine does not drive.	<ol style="list-style-type: none"> <li>1. Traction belt is worn, loose or broken.</li> <li>2. Traction belt is off pulley.</li> </ol>	<ol style="list-style-type: none"> <li>1. Adjust belt tension, replace belt.</li> <li>2. Contact Authorized Service Dealer.</li> </ol>





