



Traction Unit

for Greensmaster® 3250-D

Model No. 04383—200000943 and Up

Parts Catalog

Ordering Replacement Parts

To order replacement parts, please supply: the part number, the quantity, and the description of each part desired.

Understanding Reference Numbers

Each identified part in an illustration has a reference number. The reference number for a part also appears in the parts list, along with other information about the part.

This catalog uses two special reference number formats, one to indicate parts in a service assembly and another to indicate the quantity of a given part in an illustration.

Service Assembly Reference Numbers

Parts in service assemblies have reference numbers in the form **a:b**. The **a** represents the reference number of the entire service assembly and the **b** represents a sequential number unique to each part within the service assembly.

For example, a wheel assembly might be identified by reference number **6**, the tire by **6:1**, the valve by **6:2**, and the wheel by **6:3**. When you order the assembly identified by reference number **6**, you receive all parts identified by reference numbers **6:1**, **6:2**, and **6:3**. However, you may also order any part individually.

Reference numbers of this type appear in illustrations and in part lists.

Reference Numbers Indicating Quantity

In an illustration, if a reference number indicates more than one part, the reference number has the form **nX y**. The **n** represents the quantity of the part, the **X** is the multiplication symbol, and the **y** represents the reference number.

For example, in an illustration, the reference number **2X 37** means that two of the parts identified by reference number **37** are indicated.

Contents

Description	Page	Description	Page
Traction Control Assembly	3	Air Cleaner and Exhaust Assembly	21
Brake Pedal Assembly	4	Air Cleaner Assembly No. 95-5805	22
Front Wheel and Brake Assembly	5	Radiator Assembly	23
Brake Assembly No. 71-1500	6	Manifold Block Installation Assembly	24
Hydraulic Motor Assembly No. 92-9199	7	Basic Mow/Lift Manifold Assembly No. 93-2240	25
Steering Arm Assembly	8	Front Bulkhead and Reel Motor Assembly	26
Steering Control Valve Assembly No. 93-2120	9	Reel Motor Assembly No. 93-1375	27
Rear Wheel Assembly	10	Rear Bulkhead and Reel Motor Assembly	28
Console Assembly	11	LH and RH Lift Arm Assembly	29
Functional Control Lever Assembly	12	Center Lift Arm Assembly	30
Seat Assembly	13	Fuel System Assembly	31
Electronics Installation Assembly	15	Hydraulic Tank and Filter Assembly	32
Hydrostat and Gear Pump Drive Assembly	16	Center Pull Frame Assembly	33
Hydrostat Assembly No. 100-3174	17	522447-0107-E2 TORO DIESEL	34
Gear Pump Assembly No. 94-6390	18	Alternator Assembly No. 99-9209	46
Neutral System Assembly	19	Starter Assembly No. 99-9693	47
Engine Installation Assembly	20		

Part Description Abbreviations

Part descriptions in this catalog may include the following abbreviations.

Abbreviation	Meaning	Abbreviation	Meaning
AR	as required	INC	incorporated
ASM	assembly	LH	left hand
CARR	carriage	NI	nylon insert
DEG	degrees	PPH	Phillips pan head
FH	flat head	PTH	Phillips truss head
GA	gauge	PTO	power take off
HF	hex flange	RH	right hand
HH	hex head	SFH	slotted fillister head
HHF	hex head flange	SHH	slotted hex head
HLH	hex lag head	SQH	square head
HJ	hex jam	SHWH	slotted hex washer head
HOC	height-of-cut	SPH	slotted pan head
HS	hex socket	SRH	slotted round head
HSBH	hex socket button head	STD	standard
HSFH	hex socket flat head	TAP	self tapping
HSH	hex socket head	TTH	Torx truss head
HWH	hex washer head	WH	wing head
HWHTF	hex washer head thread forming		

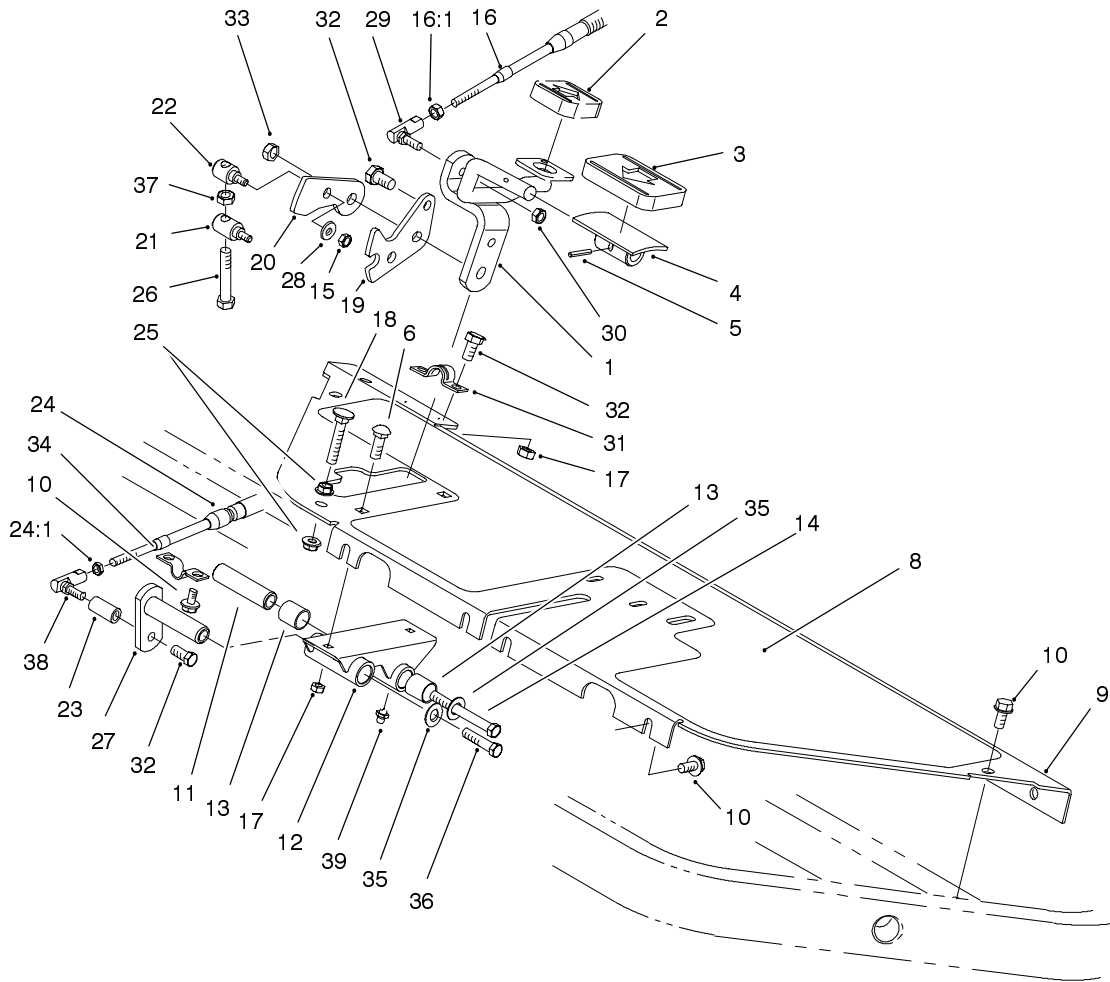

Sheet No.:2

Traction Control Assembly

Ref. No.	Part No.	Qty.	Description
1	93-2085-01	1	Rod
2	74-9110	1	Pad-Pedal, Reverse
3	74-9100	1	Pad-Pedal, Forward
4	49-6440-03	1	Pedal-Forward
5	32121-45	1	Pin-Spring
6	33124-020	2	Screw-CARR
8	93-2142	1	Pad-Plate, Floor
9	94-6399-01	1	Plate - Floor
10	32144-14	8	Screw-HWH
11	94-1371	1	Spacer
12	94-1383	1	Pedal - Pivot
13	256-311	4	Bushing-Split
14	33115-090	1	Screw-HH
15	33023-00	2	Nut-Lock
16	93-2099	1	Cable-Control, Traction
16:1	3220-1	2	Nut-Jam
17	33024-00	4	Nut-Lock
18	17-9420	1	Screw - Handle
19	94-1373	1	Bracket - Lock
20	94-1372	1	Bracket - Mow
21	94-1375	1	Trunnion-Bracket, Lock
22	94-1374	1	Trunnion-Bracket, Mow
23	94-1386	1	Shaft-Pedal, Pivot

Ref. No.	Part No.	Qty.	Description
24	94-1304	1	Cable-Lock, Neutral
24:1	3219-14	2	Nut-Hex
25	32128-20	2	Nut-HF
26	94-3489	1	Capscrew-HH
27	94-1300	1	Lock-Neutral
28	3256-1	2	Washer-Flat
29	2411-34	1	Joint-Ball
30	3296-13	1	Nut-Lock NI
31	93-2092	1	Clamp - Cable
32	33114-016	2	Screw-HH
33	33025-00	1	Nut-Lock
34	93-2279	1	Clamp - Cable
35	3256-24	2	Washer-Flat
36	33115-016	1	Screw-HH
37	33014-00	1	Nut-Hex
38	2411-38	1	Joint-Ball
39	302-5	1	Fitting - Grease

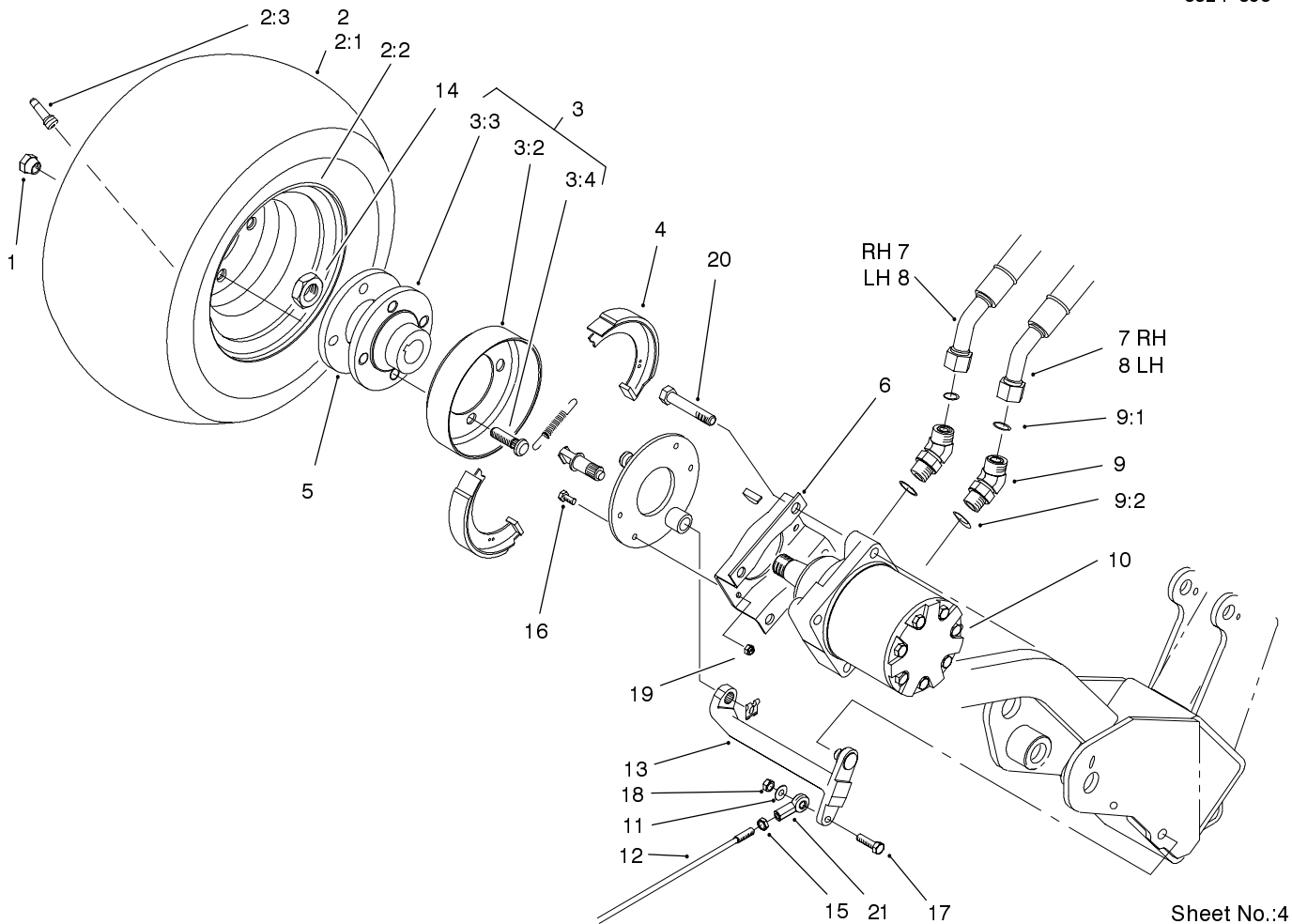

Front Wheel and Brake Assembly

Ref. No.	Part No.	Qty.	Description
1	242-50	8	Nut - Lug
2	99-8186	2	Tire ASM
2:1	70-8500	1	Tire
2:2	94-6116	1	Wheel - Rear
2:3	232-27	1	Stem-Valve
3	10-6821	2	Brake Drum ASM
3:2	10-6850	1	Drum-Brake
3:3	10-6870-03	1	Hub-Wheel
3:4	85-6540	4	Stud-Drive
4	71-1500	2	Brake ASM
5	92-9154-03	2	Plate-Bearing
6	84-2000-03	2	Bracket-Brake
7	94-5357	2	Hose ASM
8	94-5358	2	Hose ASM
9	340-14	4	Fitting-Hyd., 45°
9:1	237-65	1	O-Ring
9:2	237-80	1	O-Ring
10	92-9199	2	Motor-Hydraulic
11	3256-23	2	Washer-Flat
12	93-2069	2	Rod - Brake
13	93-2096	2	Lever - Brake
14	26-3790	2	Nut-Lock
15	3220-20	2	Nut-Jam
16	33113-020	8	Screw-HH
17	33114-030	2	Screw-HH
18	33024-00	2	Nut-Lock

Ref. No.	Part No.	Qty.	Description
19	33023-00	8	Nut-Lock
20	33116-060	8	Screw-HH
21	93-2070	2	Clevis - Swivel

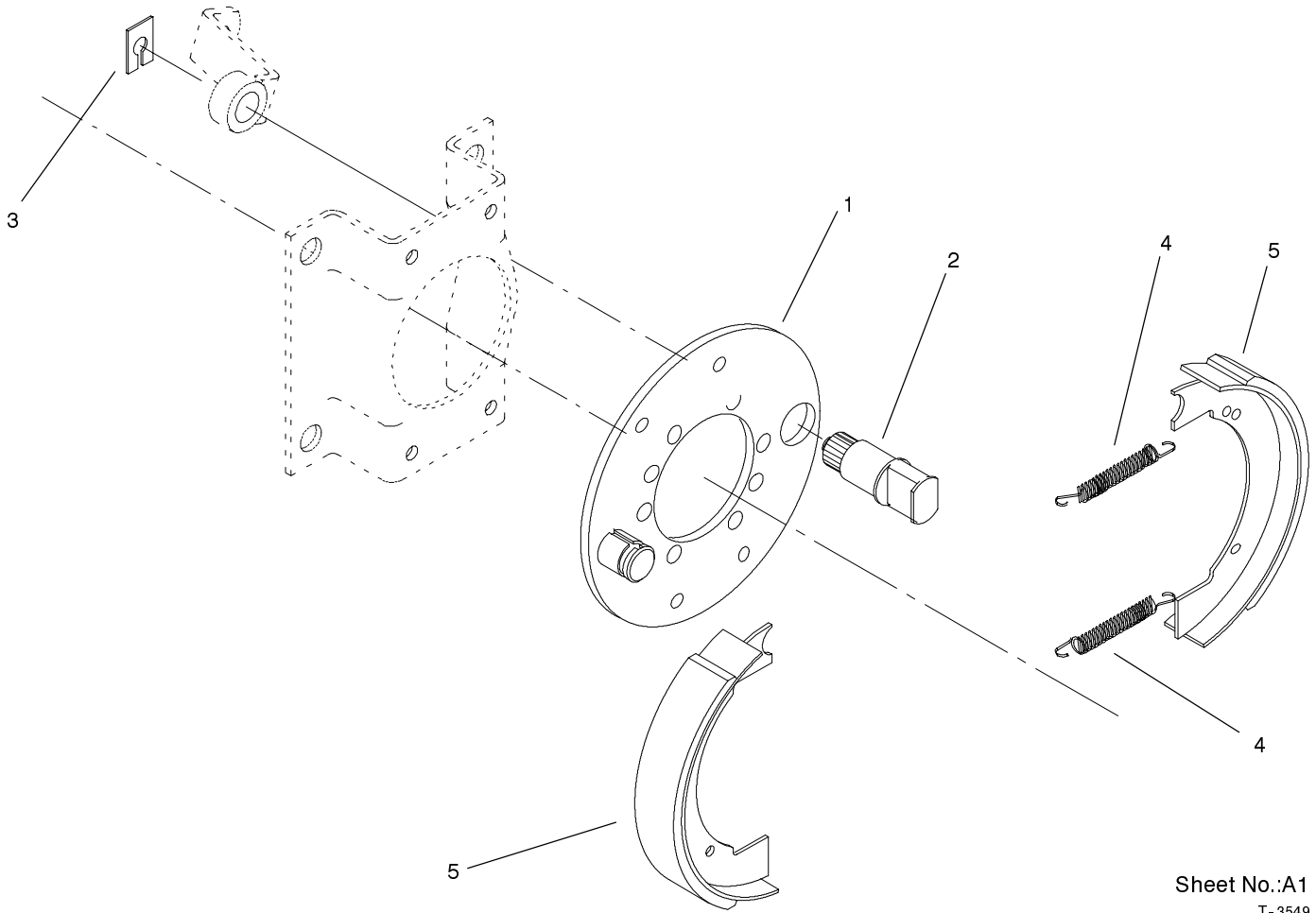

Sheet No.:A1
T-3549

Brake Assembly No. 71-1500

Ref. No.	Part No.	Qty.	Description
1	70-9870	1	Plate-Backing
2	70-9860	1	Cam-Brake
3	70-9850	1	Clip-Retaining
4	70-9880	2	Spring-Return
5	70-9840	2	Shoe-Brake

Ref. No.	Part No.	Qty.	Description

PROTOTYPE

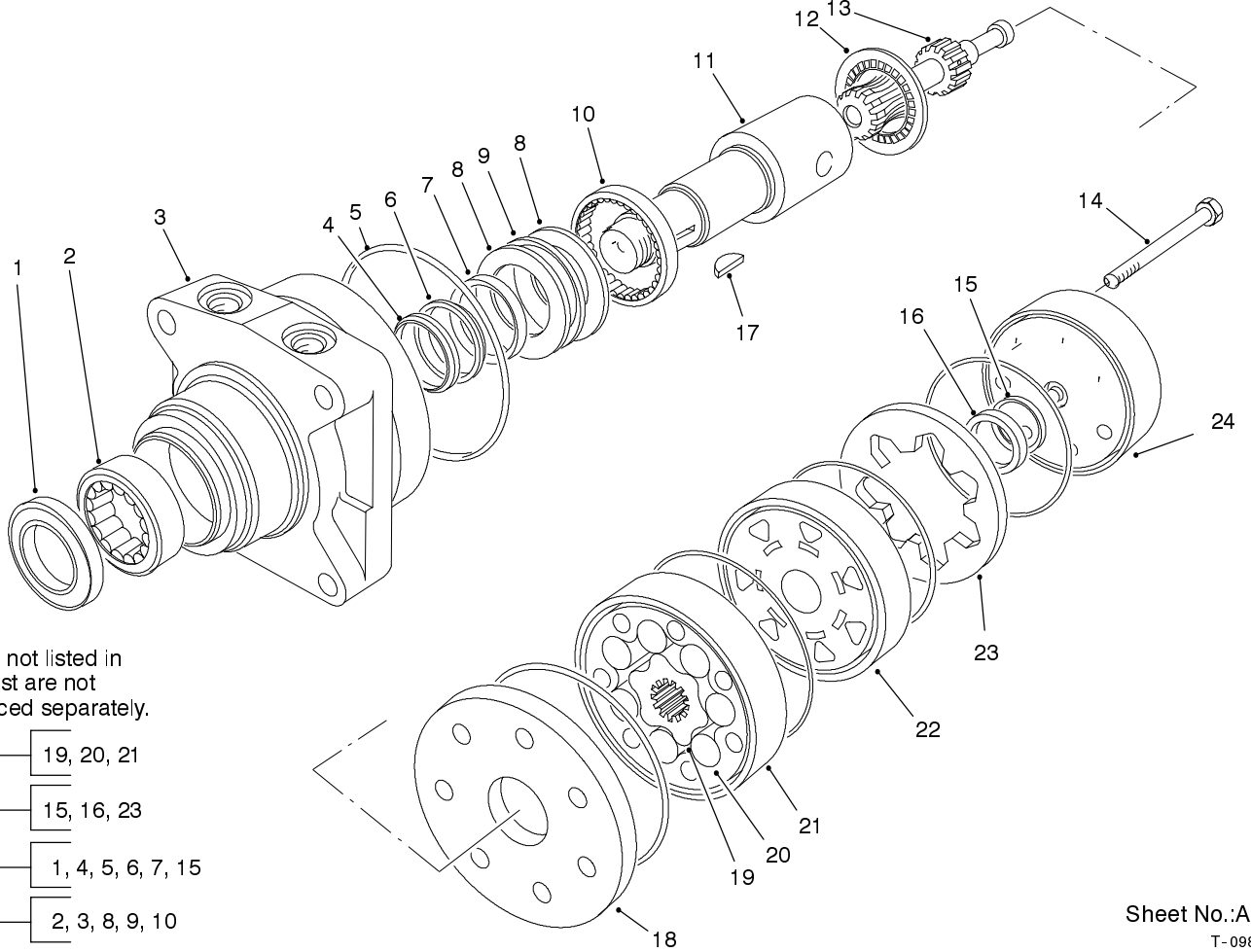

Parts not listed in partlist are not serviced separately.

- 25 — 19, 20, 21
- 26 — 15, 16, 23
- 27 — 1, 4, 5, 6, 7, 15
- 28 — 2, 3, 8, 9, 10

Sheet No.:A2
T-0983

Hydraulic Motor Assembly No. 92-9199

Ref. No.	Part No.	Qty.	Description
11	76-0860	1	Shaft-Coupling
12	76-0850	1	Bearing-Thrust
13	92-9761	1	Link - Drive
14	92-9762	7	Screw-Cap, Hex Head
17	3257-42	1	Key-Woodruff
18	76-0870	1	Plate-Wear
22	76-0840	1	Manifold
24	76-0940	1	End Cover ASM
25	92-9763	1	Set-Rotor
26	76-0880	1	Commutator ASM
27	94-8178	1	Kit-Seal
28	76-0810	1	Wheel-Motor Housing ASM

Ref. No.	Part No.	Qty.	Description

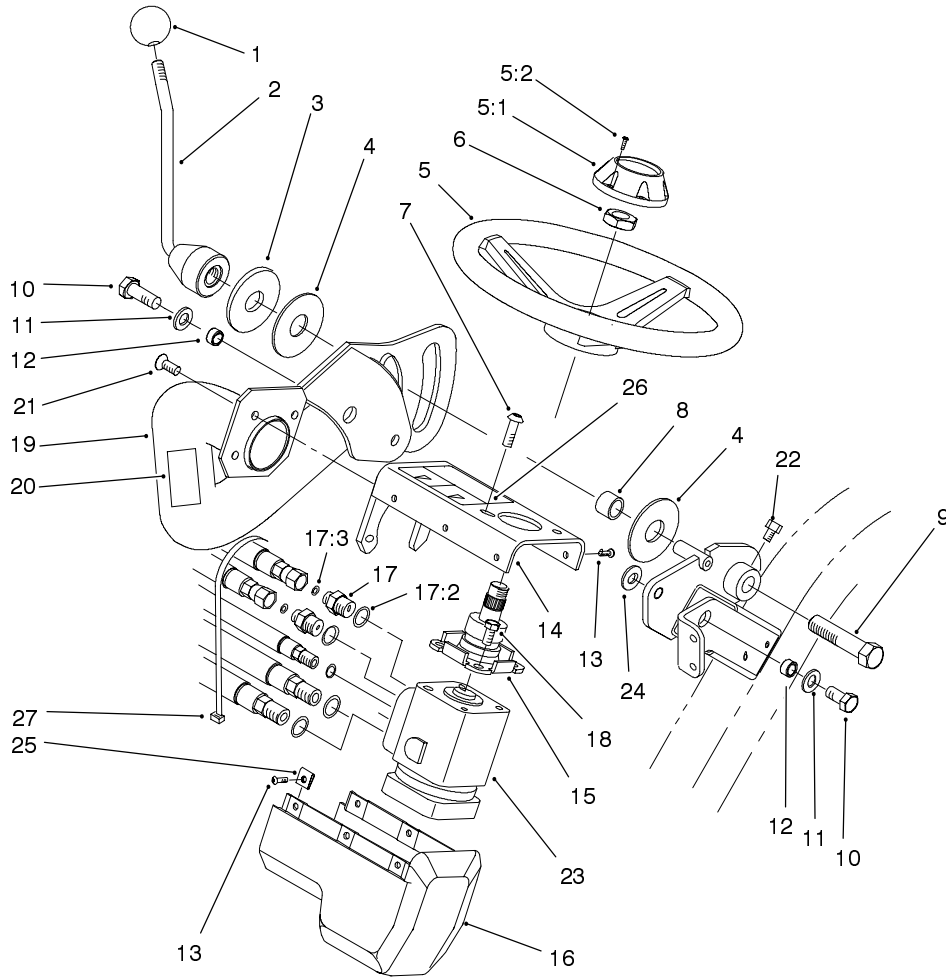

Sheet No.:5

Steering Arm Assembly

Ref. No.	Part No.	Qty.	Description
1	233-48	1	Knob
2	93-2400-03	1	Handle-Lockup
3	83-0760	1	Spacer-Plate, Lockup
4	83-0740	2	Disc - Friction
5	68-5130	1	Wheel-Steering
5:1	68-5140	1	Cap-Wheel, Steering
5:2	32144-21	1	Screw
6	47-6990	1	Nut
7	3274-63	2	Screw-HSH
8	83-0730	1	Spacer-Lockup
9	93-2199	1	Screw - HH (RH)
10	325-4	2	Screw-HH
11	3256-26	2	Washer-Flat
12	47-2890	2	Bushing
13	3274-39	6	Screw-HSBH
14	94-3461-03	1	Cover-Steering
15	83-1420	1	Column-Steering
16	94-6366	1	Cover-Valve, Steering
17	340-133	2	Adapter
17:2	237-79	1	O-Ring
17:3	237-21	1	O-Ring
18	323-4	2	Screw-HH
19	93-2115-01	1	Arm-Steering
20	93-8068	1	Decal-Arm, Steering
21	3274-80	3	Screw-HH
22	3242-2	1	Screw-SQH

Ref. No.	Part No.	Qty.	Description
23	93-2120	1	Valve-Control, Steering
24	65-6390	1	Washer - Thrust, Plain
25	3290-277	6	Nut-Speed
26	93-8063	1	Decal-Warning (Int'l)
27	3290-379	1	Tie-Cable

PROTOTYPE

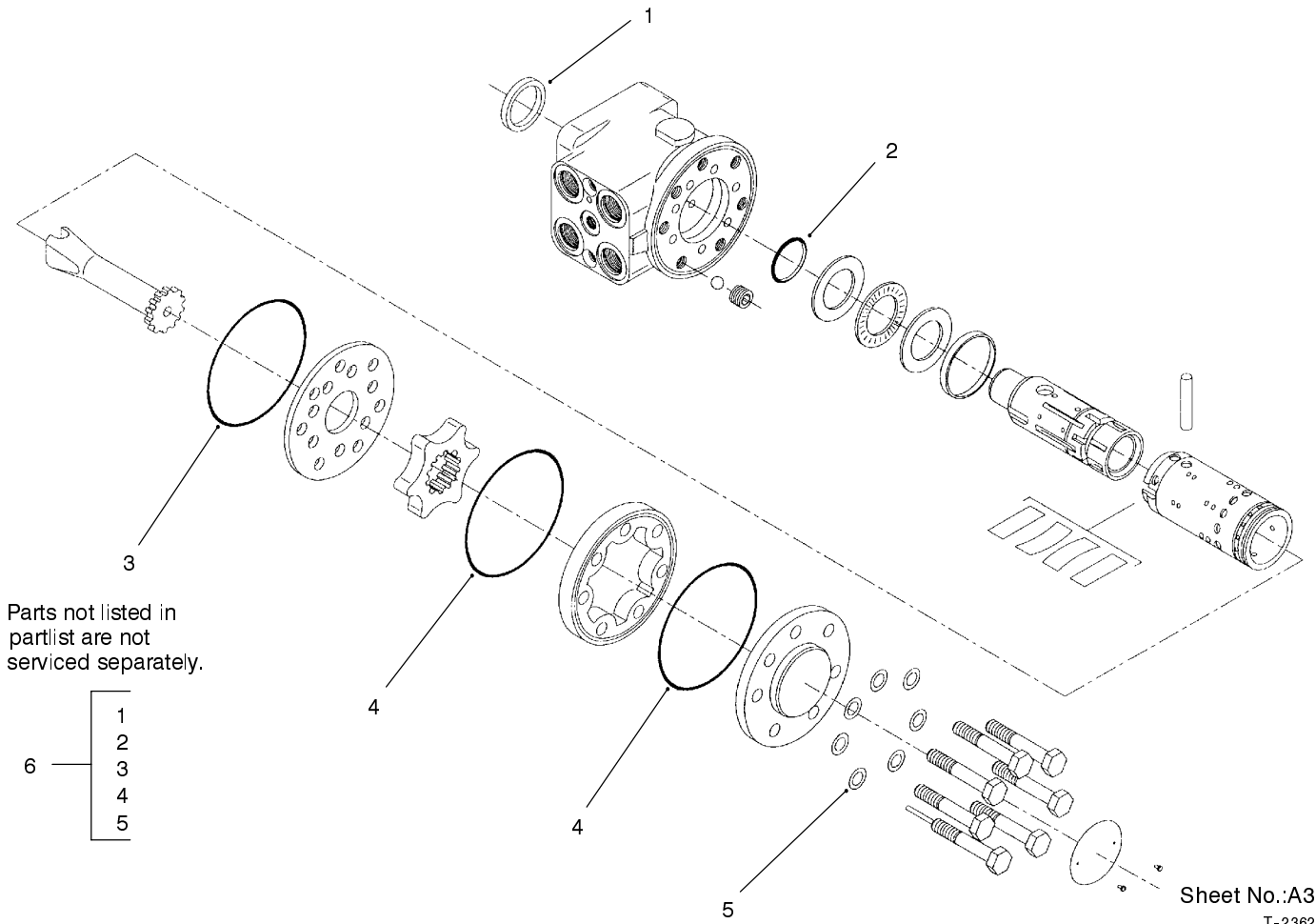

Sheet No.:A3
T-2362

Steering Control Valve Assembly No. 93-2120

Ref. No.	Part No.	Qty.	Description
6	94-4929	1	Kit - Seal

Ref. No.	Part No.	Qty.	Description
<i>PROTOTYPE</i>			

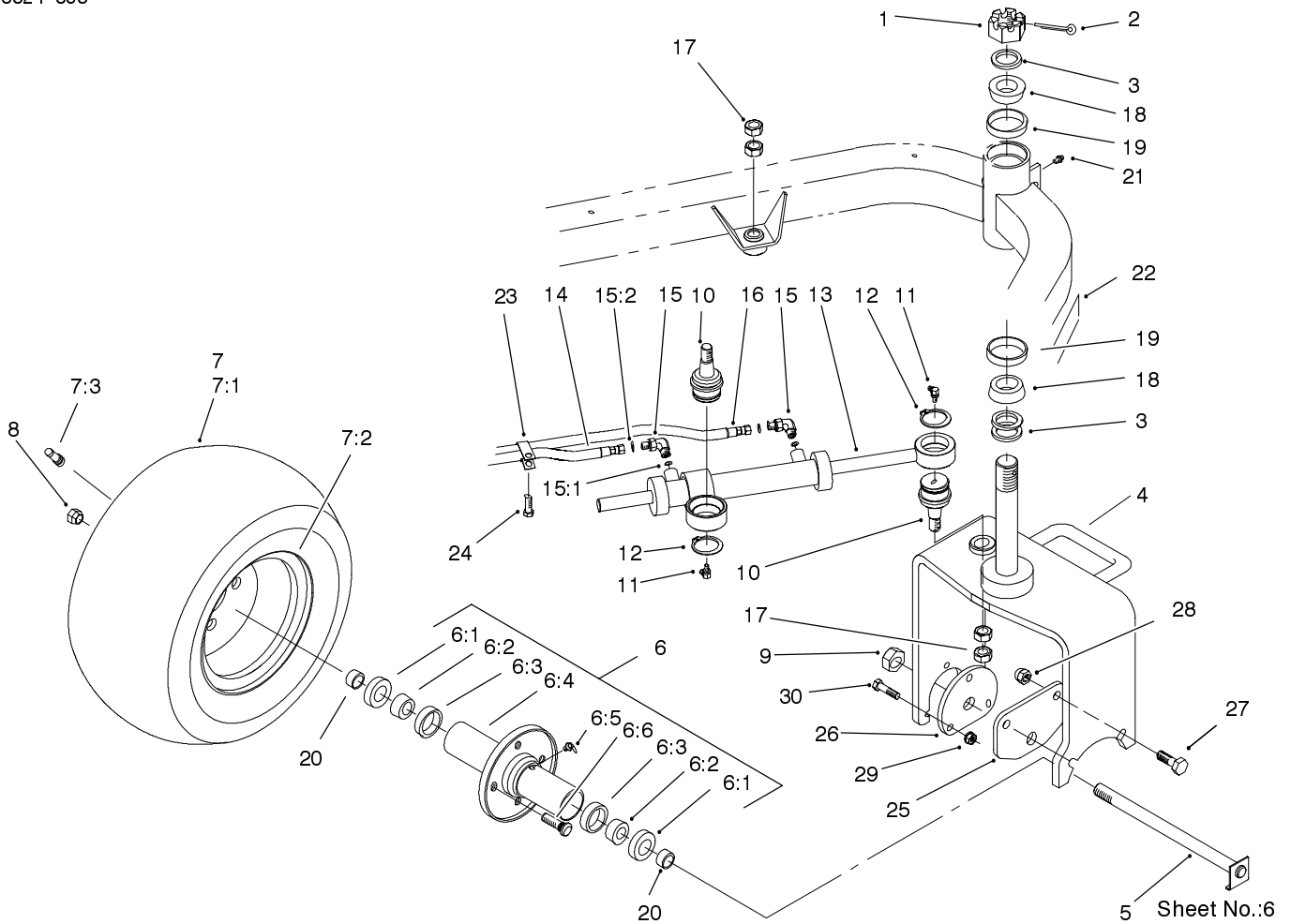

Rear Wheel Assembly

Ref. No.	Part No.	Qty.	Description
1	32136-9	1	Nut-Hex, Slot
2	3272-37	1	Pin-Cotter
3	18-6320	3	Washer-Steering
4	99-1492-01	1	Castor Fork ASM
5	70-8370	1	Bolt
6	72-9710	1	Hub-Tire, Sulky
6:1	253-111	2	Seal-Oil
6:2	254-78	2	Cone-Bearing
6:3	254-79	2	Bearing-Roller, Cup
6:4	75-9440	1	Hub ASM
6:5	302-55	1	Zerk
6:6	10-6830	4	Stud-Type, Drive
7	99-8186	1	Tire ASM
7:1	70-8500	1	Tire
7:2	94-6116	1	Wheel - Rear
7:3	232-27	1	Stem-Valve
8	242-50	4	Nut - Lug
9	3296-67	1	Nut-Lock NI
10	92-5838	2	Joint-Ball
11	302-60	2	Fitting-Lube
12	32151-104	2	Ring-Retaining, External
13	93-2122	1	Steering Cylinder ASM
*13:1	94-4398	1	Kit-Repair, Seal
14	93-2270	1	Hydraulic Hose ASM
15	340-132	2	Elbow-90°

Ref. No.	Part No.	Qty.	Description
15:1	237-78	1	O-Ring
15:2	237-21	1	O-Ring
16	93-2269	1	Hydraulic Hose ASM
17	3220-6	4	Nut-Jam
18	254-70	2	Cone-Bearing
19	254-61	2	Cup-Bearing
20	70-8490	2	Spacer-Spindle, Rear
21	302-5	1	Fitting - Grease
22	99-1493	1	Decal-Greensmaster 3250-D
23	92-5753	1	Clamp-Hose
24	32144-14	1	Screw-HWH
25	99-1485-01	1	Plate-Adapter, Motor
26	99-1486-01	1	Plate-Adapter
27	325-6	2	Screw-HH
28	3296-23	2	Nut-Lock, NI
29	3296-39	3	Nut-Lock, NI
30	323-8	3	Screw-HH

* Not illustrated

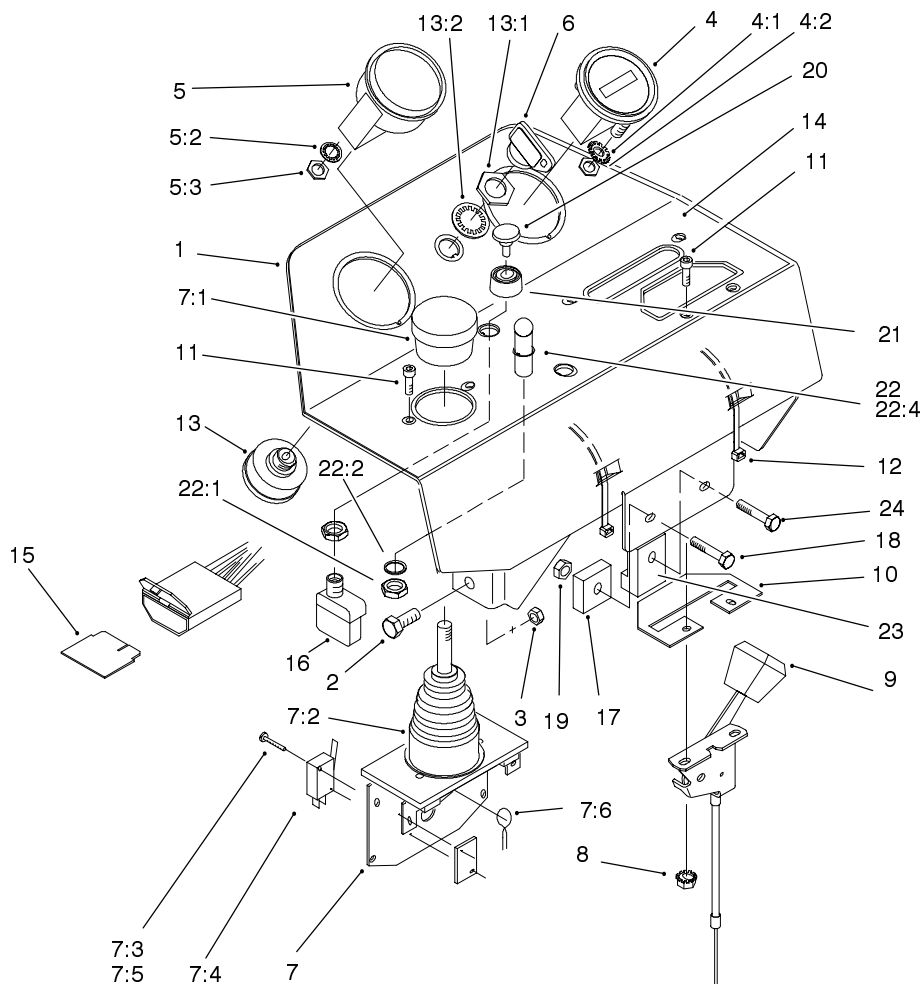

Sheet No.:7

Console Assembly

Ref. No.	Part No.	Qty.	Description	Ref. No.	Part No.	Qty.	Description
1	100-3185-03	1	Console ASM	13:1	218-446	1	Nut-Hex
2	33114-020	4	Screw-HH	13:2	218-447	1	Washer-Lock
3	33024-00	4	Nut-Lock	14	100-3183	1	Decal-Panel, Control
4	66-2950	1	Gauge-Hourmeter	15	92-3188	1	Diode-Board, Circuit
4:1	3255-20	2	Washer-Lock	16	72-9760	1	Switch
4:2	3217-25	2	Nut-Hex	17	92-2538	1	Timer-Plug, Glow
5	93-7053	1	Cluster-Lamp, Warning	18	33113-030	1	Screw-HH
*5:1	219-17	4	Bulb	19	33023-00	2	Nut-Lock
5:2	3254-1	1	Washer-Lock/Int	20	43-6280	1	Button-Push
5:3	3217-26	1	Nut-Hex	21	43-6420	1	Bezel
6	63-8360	1	Key-Ignition	22	44-2212	1	Light ASM -Indicator, Amber
7	98-2195	1	Joystick	22:1	218-535	1	Nut-Hex
7:1	3290-489	1	Knob	22:2	218-536	1	Washer-Lock
7:2	3290-488	1	Boot	22:4	218-562	1	Lens
7:3	3290-354	2	Nut-Speed	23	99-9666	1	Module
7:4	218-590	2	Switch	24	33113-020	1	Screw-HH
7:5	3290-93	4	Screw-Head, Pan				
7:6	93-3625	1	Spring - Return				
8	32149-8	2	Nut-Keps				
9	99-8150	1	Control-Throttle (Diesel)				
10	99-8195-03	1	Plate-Cover				
11	3273-26	4	Screw-HSH				
12	3290-378	2	Tie-Cable				
13	27-2360	1	Switch-Key				

* Not illustrated

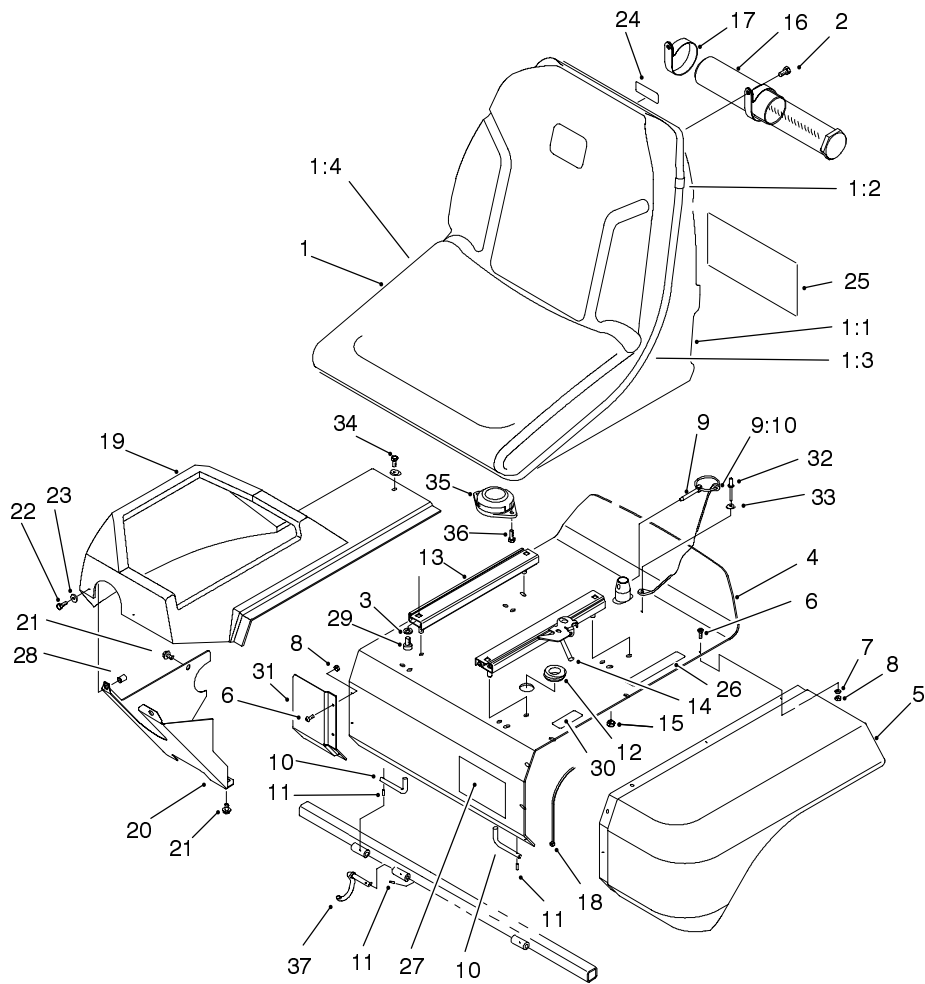

Sheet No.:9

Seat Assembly

Ref. No.	Part No.	Qty.	Description
1	100-3187	1	Seat ASM
1:1	92-6534	1	Shell
1:2	351-80	1	Clip
1:3	351-78	1	Edging
1:4	100-6411	1	Cushion-Replacement
2	322-2	2	Screw-HH
3	3256-23	4	Washer-Flat
4	93-2135-03	1	Seat Support
5	93-2128	1	Panel-Base, Seat
6	3274-39	9	Screw-HSBH
7	3256-77	6	Washer-Flat
8	3296-12	9	Nut-Lock
9	77-3780	1	Pin ASM
9:10	28-8070	1	Lanyard
10	93-2422	2	Rod-Pivot, Seat
11	32121-7	3	Pin-Spring
12	237-100	1	Grommet
13	92-8990	1	Adjuster - 7"
14	92-8991	1	Adjuster w/Latch
15	3296-29	4	Nut-Lock
16	74-0720	1	Tube-Manual
17	2412-133	2	R-Clamp
18	3290-378	1	Tie-Cable
19	99-4208	1	Shroud-Console
20	94-4547-01	1	Panel - Lower, RH
21	32144-14	2	Screw-HWH

Ref. No.	Part No.	Qty.	Description
22	33113-016	2	Screw-HH
23	3256-1	3	Washer-Flat
24	93-8067	1	Decal-Oil, Hydraulic
25	100-3150	1	Decal-Service (Spanish)
25	100-3151	1	Decal-Service (French)
25	100-3152	1	Decal-Service (German)
25	100-3153	1	Decal-Service (Swedish)
25	100-3154	1	Decal-Service (Italian)
25	100-3155	1	Decal-Service (Portuguese)
25	100-3156	1	Decal-Service (Norwegian)
25	100-3157	1	Decal-Service (Finnish)
25	100-3158	1	Decal-Service (Danish)
25	100-3159	1	Decal-Service (Dutch)
25	100-3160	1	Decal-Service (Japan)
26	93-6689	1	Decal - No Riders
27	94-2579	1	Decal - Toro
28	93-5447	2	Nut-Clinch

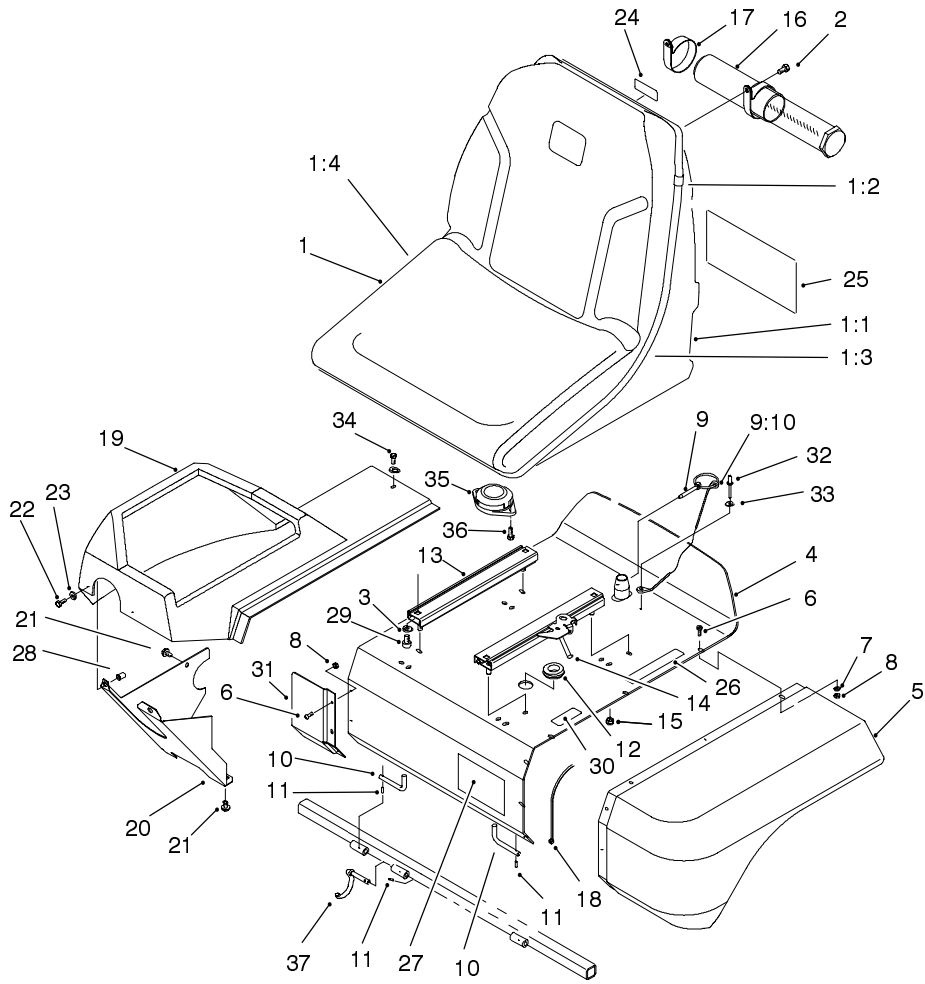

Sheet No.:9

Seat Assembly (Continued)

Ref. No.	Part No.	Qty.	Description
29	3274-12	4	Screw-HSH
30	93-7252	1	Decal-International
31	94-4546-01	1	Panel-Extension
32	3290-282	1	Rivet-Pop, Steel
33	3256-49	1	Washer-Flat
34	33113-012	1	Screw-HH
35	92-6282	1	Switch-Seat
36	32144-10	2	Screw-HWH
37	99-4247	1	Wire-Hook

Ref. No.	Part No.	Qty.	Description
<p style="font-size: 48px; opacity: 0.5; transform: rotate(-1deg);">PROTOTYPE</p>			

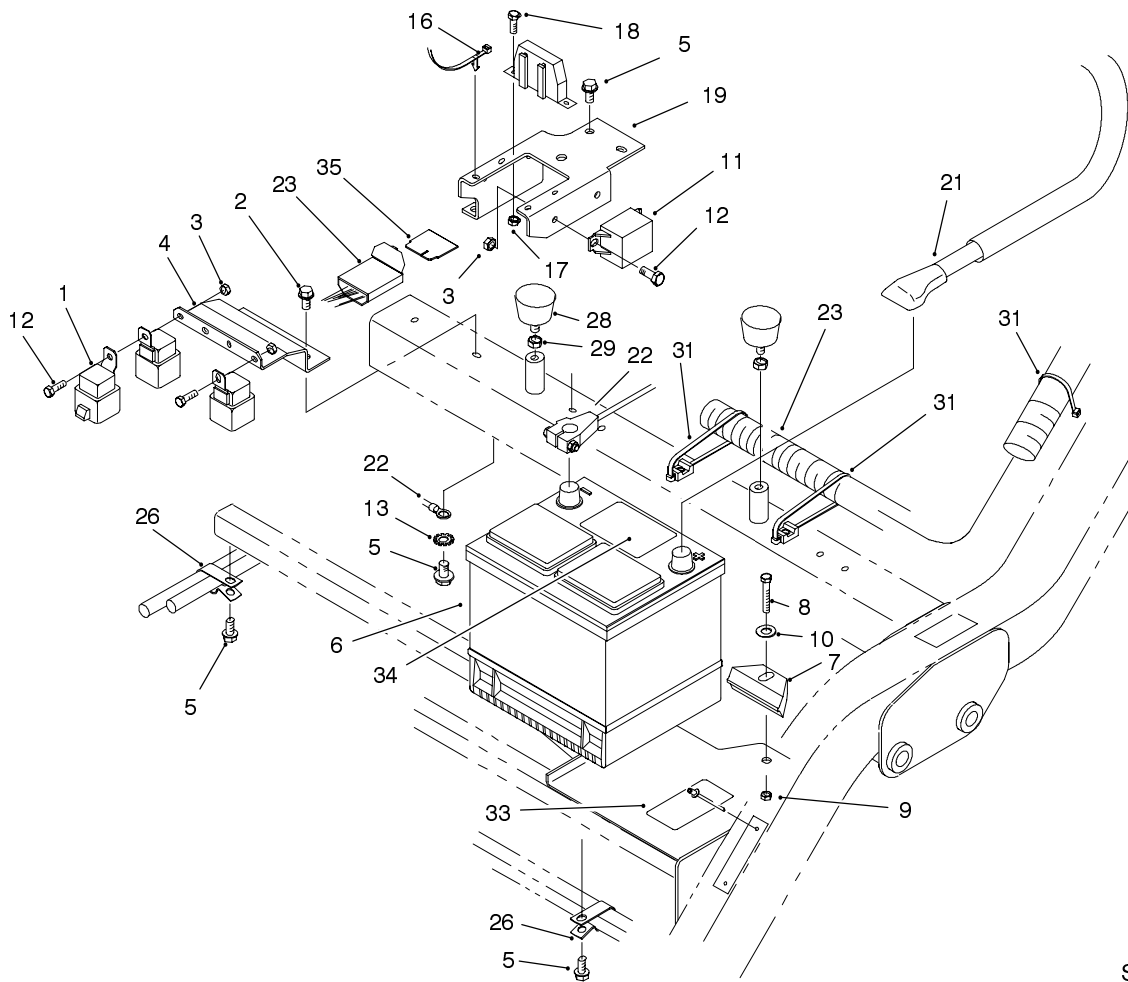

Sheet No.:10

Electronics Installation Assembly

Ref. No.	Part No.	Qty.	Description
1	70-1480	8	Relay
2	32144-11	2	Screw-TAP
3	33023-00	6	Nut-Lock
4	93-2169-01	1	Bracket - Relay
5	32144-14	5	Screw-HWH
6	66-2750	1	Battery
7	66-2490	1	Retainer-Battery
8	33115-040	1	Screw-HH
9	33025-00	1	Nut-Lock
10	3256-24	1	Washer-Flat
11	66-8800	1	Relay
12	33113-016	6	Screw-HH
13	3254-2	1	Washer-Lock, Internal
16	94-1325	2	Tie-Mount, Push
17	3296-2	2	Nut-Lock
18	32105-13	2	Screw-Shh
19	100-3186-03	1	Bracket-Holder, Fuse
21	95-8853	1	Cable-Battery, Positive
22	99-8167	1	Cable-Battery, Negative
23	99-8165	1	Harness-Wire, Gr3250d
26	92-5753	2	Clamp-Hose
28	68-3270	2	Bumper-Rubber
29	3218-2	2	Nut-Jam

Ref. No.	Part No.	Qty.	Description
31	3290-378	6	Tie-Cable
33	93-6668	1	Decal - Battery
34	93-7276	1	Decal-Danger
35	92-3188	1	Diode-Board, Circuit

PROTOTYPE

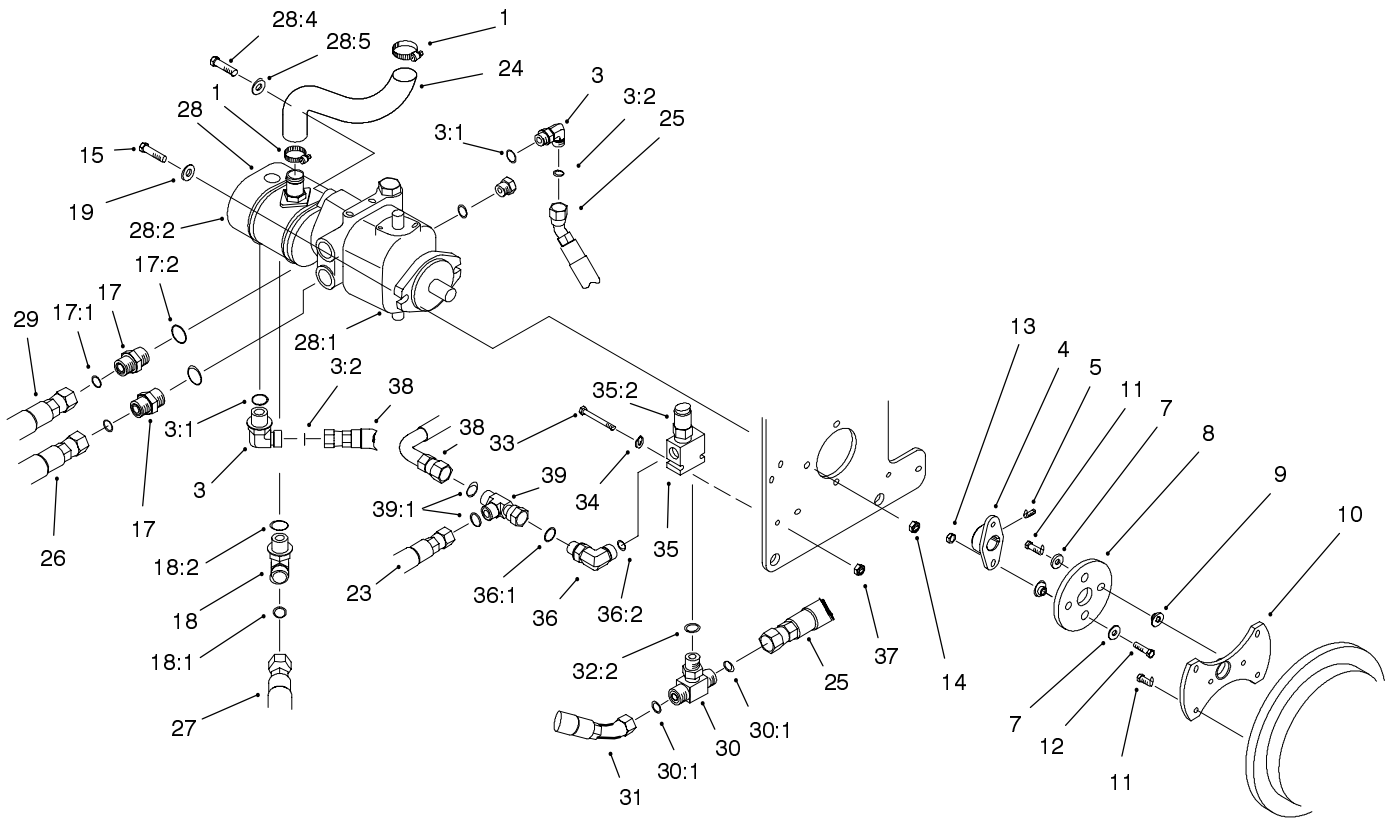

Sheet No.:11

Hydrostat and Gear Pump Drive Assembly

Ref. No.	Part No.	Qty.	Description
1	2412-34	2	Clamp-Hose
3	340-18	2	Fitting
3:1	237-79	1	O-Ring
3:2	237-22	1	O-Ring
4	93-2589	1	Hub - Pump
5	3241-6	2	Screw-SQH
7	3256-3	2	Washer-Flat
8	80-8650	1	Coupling - Drive
9	27-6600	4	Spacer-Coupling, Rubber
10	93-2220-03	1	Adapter-Pump
11	33114-020	6	Screw-HH
12	33114-030	1	Screw-HH
13	33024-00	2	Nut-Lock
14	33025-00	2	Nut-Lock
15	33115-040	2	Screw-HH
17	340-8	2	Adapter
17:1	237-65	1	O-Ring
17:2	237-81	1	O-Ring
18	340-17	1	Adapter
18:1	237-65	1	O-Ring
18:2	237-80	1	O-Ring
19	100-4852	2	Washer - Hardened
23	99-4218	1	Hose ASM
24	99-1905	1	Hose-Inlet, Pump
25	94-6384	1	Hose ASM

Ref. No.	Part No.	Qty.	Description
26	99-4220	1	Hose ASM
27	99-4216	1	Hose ASM
28	99-8152	1	Pump-Gear, Hydro
28:1	100-3174	1	Hydrostat ASM
28:2	94-6390	1	Pump-Gear
*28:3	60-3520	1	O-Ring
28:4	3274-1	2	Screw-HSH
28:5	3256-24	2	Washer-Flat
29	99-4217	1	Hose ASM
30	340-94	1	Adapter
30:1	237-22	2	O-Ring
30:2	237-42	1	O-Ring
31	99-4215	1	Hose ASM
33	33113-050	2	Screw-HH
34	3256-22	2	Washer-Flat
35	94-6385	1	Valve - Relief
35:2	94-6386	1	Cartridge-Valve, Relief
36	340-77	1	Fitting-90°
36:1	237-22	1	O-Ring
36:2	237-42	1	O-Ring
37	33023-00	2	Nut-Lock
38	99-4219	1	Hose ASM
39	340-115	1	Fitting-Tee
39:1	237-22	2	O-Ring

* Not illustrated

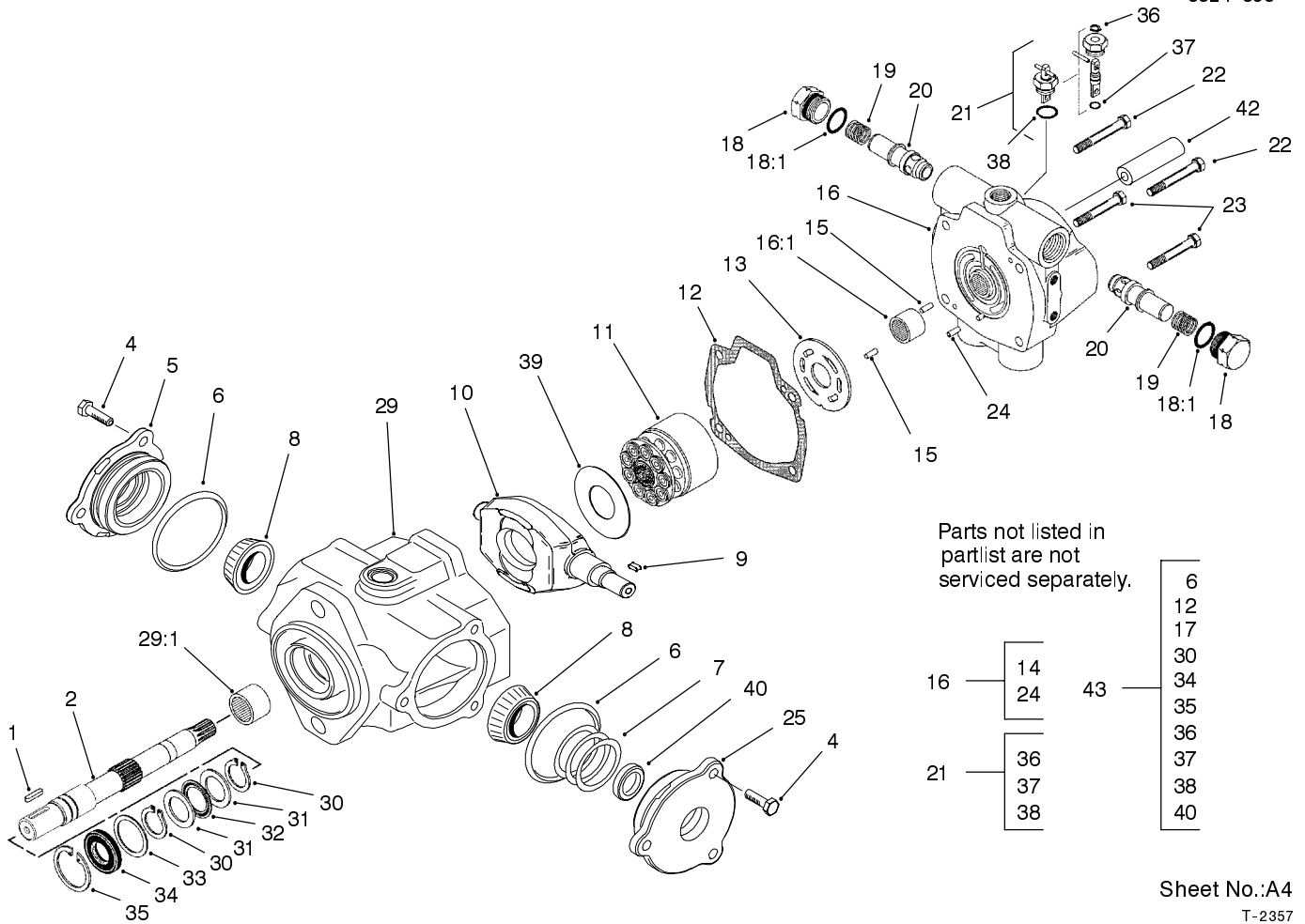

Sheet No.:A4
T-2357

Hydrostat Assembly No. 100-3174

Ref. No.	Part No.	Qty.	Description
1	94-3645	1	Key
2	94-6359	1	Shaft - Drive
4	98-4640	6	Screw - Cap
5	98-4644	1	Cover Plate ASM
6	100-3179	2	O-Ring
7	100-3182	2	Kit-Shim
8	98-4639	2	Bearing-Cone
9	94-3646	1	Key
10	100-3175	1	Camplate
11	76-6070	1	Rotating Kit ASM
12	33-4930	1	Gasket-Housing
13	100-3180	1	Valve-Plate
15	76-6150	2	Pin-Dowel
16	100-3177	1	Back Plate ASM
16:1	94-6368	1	Bearing
18	70-1240	2	Plug ASM
18:1	60-5980	1	O-Ring
19	100-3178	2	Spring
20	94-3644	2	Seat
21	100-3181	1	Dump Valve ASM
22	76-6170	2	Capscrew
23	76-6160	2	Capscrew
25	98-4645	1	Cover Plate ASM
29	100-3176	1	Housing ASM
29:1	94-6363	1	Bearing
30	32151-29	2	Ring-Snap, External

Ref. No.	Part No.	Qty.	Description
31	252-71	2	Bearing-Thrust
32	252-66	1	Bearing-Thrust
33	33-3720	1	Washer
34	42-2720	1	Seal-External
35	32151-13	1	Ring-Snap, Internal
39	98-4635	1	Insert-Plate, Cam
42	74-9040	1	Coupler
*43	98-4643	1	Seal Repair Kit

* Not illustrated

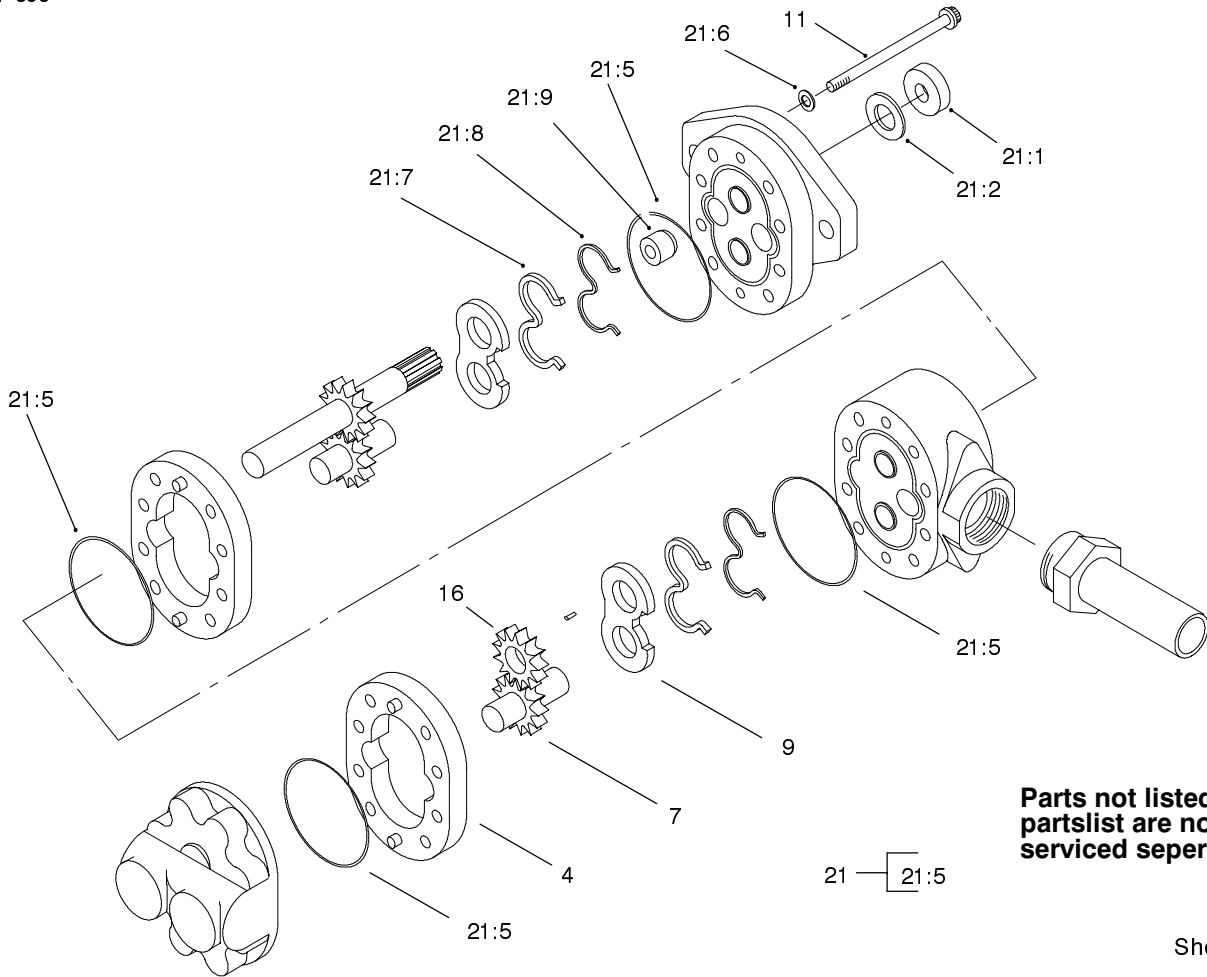

Parts not listed in partslist are not serviced separately.

Sheet No.:A5
T-3483

Gear Pump Assembly No. 94-6390

Ref. No.	Part No.	Qty.	Description
4	95-4364	1	Body
7	95-4366	1	Gear-Idler
9	95-4368	2	Plate - Wear
11	94-8158	8	Screw - Cap
16	95-4373	1	Gear-Fit, Slip
21	94-8161	1	Kit-Repair, Seal
21:1	49-2640	1	Seal-Shaft
21:2	60-5890	1	Washer
21:5		4	O-Ring
21:6	94-8160	4	Washer
21:7	95-4369	2	Seal
21:8	95-4367	2	Gasket-Back-Up
21:9	94-3011	1	Plug

Ref. No.	Part No.	Qty.	Description

PROTOTYPE

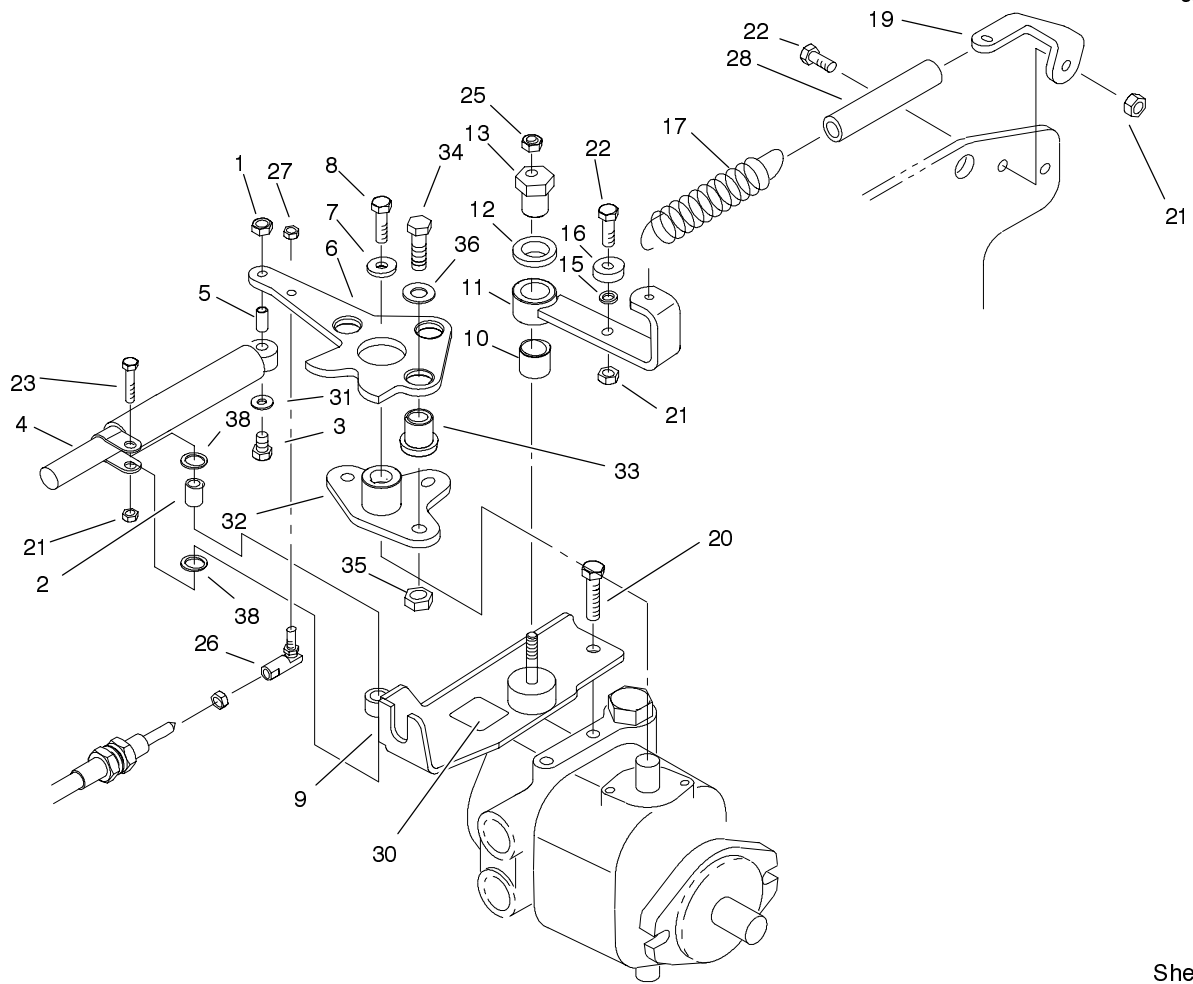

Sheet No.:12

Neutral System Assembly

Ref. No.	Part No.	Qty.	Description	Ref. No.	Part No.	Qty.	Description
1	33023-00	1	Nut-Lock	30	93-9051	1	Decal-Bolt, Eccentric
2	94-8197	1	Tube - Pivot	31	3256-22	1	Washer-Flat
3	33113-030	1	Screw-HH	32	94-3486	1	Plate
4	76-8870	1	Lever Damper ASM	33	63-9750	3	Mount
5	94-1312	1	Spacer - Pivot	34	33115-035	3	Screw-HH
6	94-3488-03	1	Lever - Pump	35	33025-00	3	Nut-Lock
7	88-7200	1	Washer-Flat	36	2844	3	Washer
8	3210-6	1	Screw-HH	38	94-8196	2	Washer - Nylon
9	100-9846	1	Support-Cable, Welded				
10	94-9609	1	Bushing - Straight				
11	94-4527	1	Arm-Neutral				
12	3-6498	1	Washer-Thrust				
13	93-2111	1	Stud - Traction				
15	75-5470	1	Spacer-Bearing				
16	251-259	1	Bearing				
17	99-4254	1	Spring-Extension				
19	99-4276	1	Bracket-Spring				
20	323-4	2	Screw-HH				
21	33024-00	3	Nut-Lock				
22	33114-025	2	Screw-HH				
23	33114-030	1	Screw-HH				
25	3296-29	1	Nut-Lock				
26	2411-34	1	Joint-Ball				
27	3296-13	1	Nut-Lock NI				
28	99-4251	1	Hose-Dampener				

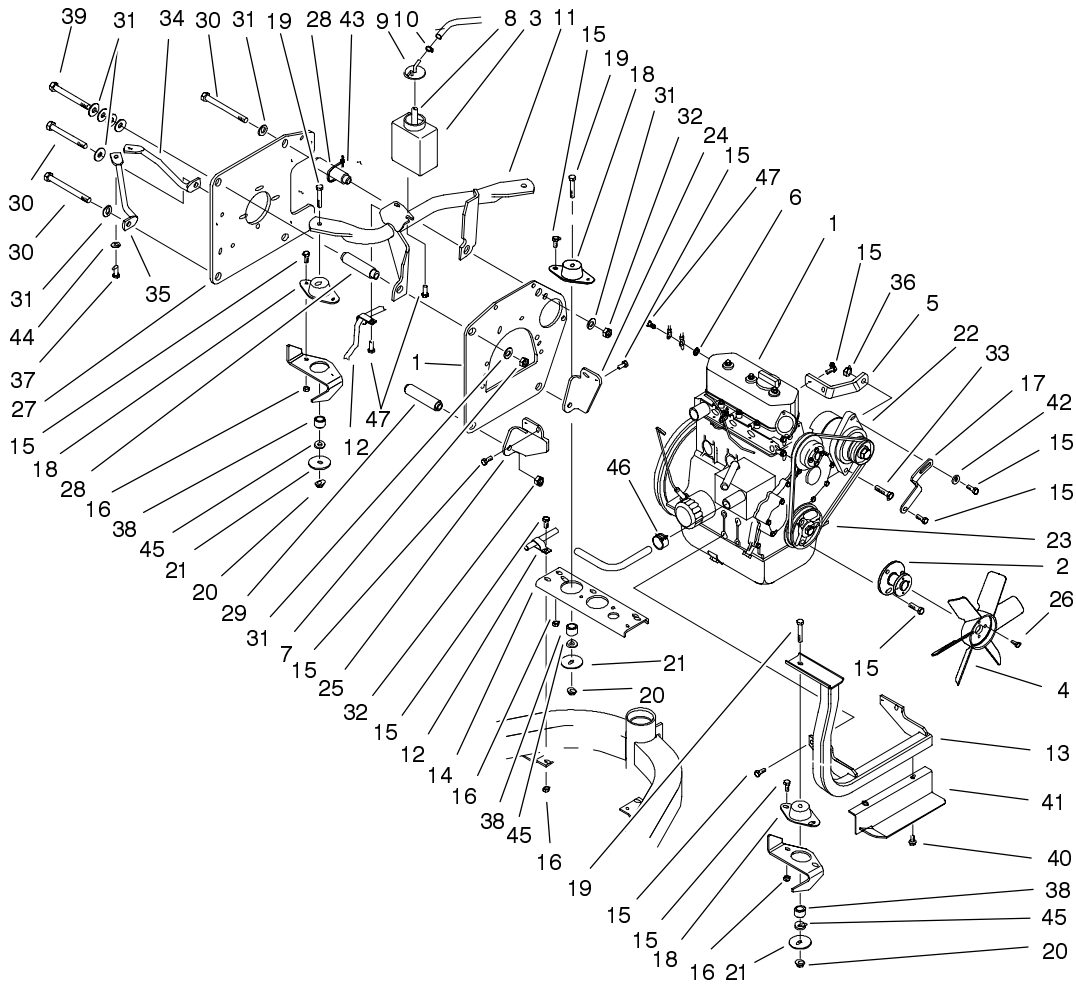

Sheet No.:13

Engine Installation Assembly

Ref. No.	Part No.	Qty.	Description
1	99-1481	1	Engine-Briggs Daihatsu 522447-0107-E2
2	99-1495	1	Adapter-Fan
3	93-2049	1	Tank-Overflow
4	93-2090	1	Fan-Engine
5	93-2445	1	Bracket-Alternator, Upper
6	3254-2	1	Washer-Lock, Internal
7	51-2070	1	Nut
8	94-1348	1	Hose-Tank, Recov
9	93-2048	1	Cap-Tank, Overflow
10	2412-108	1	Clamp-Worm
11	100-3190-03	1	Engine Mount ASM
12	92-5753	2	Clamp-Hose
13	99-1473-03	1	Mount-Engine, Front
14	93-2020-01	1	Bracket - Support
15	33114-020	26	Screw-HH
16	33024-00	4	Nut-Lock
17	93-2446	1	Bracket-Alternator, Lower
18	83-1030	3	Mount-Engine
19	323-11	3	Screw-HH
20	3290-357	3	Nut-Flange, Lock
21	83-1040	3	Washer - Flat
22	99-9209	1	Alternator

Ref. No.	Part No.	Qty.	Description
23	99-8153	1	Belt-V
24	99-4189-03	1	Bracket-Engine, LH
25	99-4188-03	1	Bracket-Engine, RH
26	33113-016	4	Screw-HH
27	99-4190-03	1	Plate-Pump
28	93-2588	2	Spacer - Upper
29	93-2174	2	Spacer
30	33116-130	3	Screw-HH
31	87-7270	9	Washer - Thrust
32	33026-00	3	Nut-Lock
33	33115-050	1	Screw-HH
34	99-4240	1	Brace-Wireform, LH
35	99-4238	1	Brace-Wireform, RH
36	33025-00	1	Nut-Lock
37	323-4	2	Screw-HH
38	94-4538	3	Spacer - Mount
39	33116-120	1	Screw-HH
40	32144-14	2	Screw-HWH
41	94-8156-03	1	Deflector - Fan
42	3256-3	1	Washer-Flat
43	3290-378	2	Tie-Cable
44	3256-24	2	Washer-Flat
45	66-6480	3	Washer
46	92-2379	1	Clamp-Hose
47	33114-016	3	Screw-HH

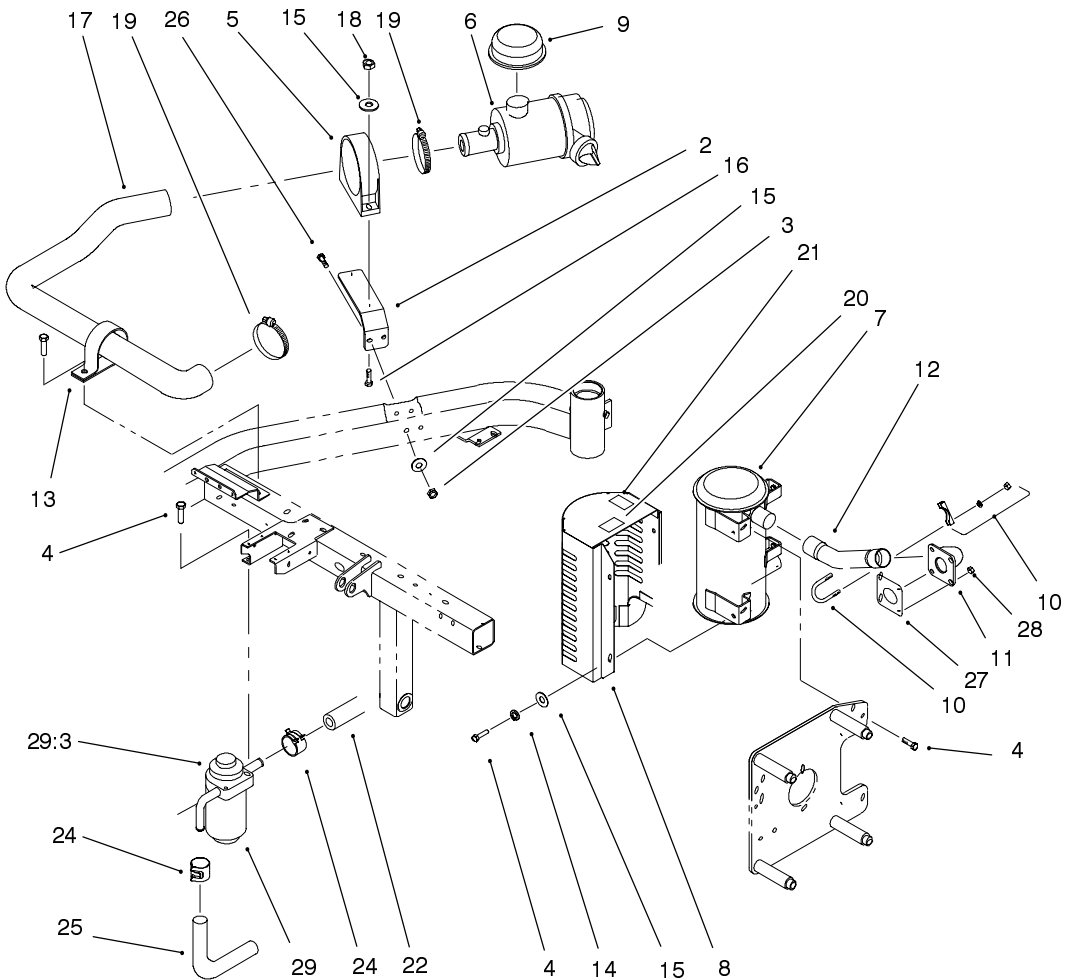

Sheet No.:14

Air Cleaner and Exhaust Assembly

Ref. No.	Part No.	Qty.	Description	Ref. No.	Part No.	Qty.	Description
2	99-4203	1	Bracket-Cleaner, Air	28	99-9176	4	Nut-Hex
3	33024-00	2	Nut-Lock	29	100-3191	1	Separator-Fuel
4	33114-020	8	Screw-HH				Filtr/Wtr (Diesel)
5	95-5806	1	Bracket-Mounting, Air Cleaner	*29:1	100-3192	1	Element-Filter, Fuel
6	95-5805	1	Air Cleaner ASM	*29:2	100-6409	1	Sensor-Filter, Fuel
7	94-8153	1	Muffler	29:3	100-6408	1	Cover-Filter
8	94-8182-03	1	Shield-Muffler				
9	46-7510	1	Hood-Inlet, Air				
10	2112-9	2	Clamp				
11	99-1472	1	Plate-Exhaust				
12	99-1494	1	Pipe - Exhaust				
13	2412-107	1	R Clamp				
14	3253-4	4	Washer				
15	3256-23	4	Washer-Flat				
16	322-16	2	Screw-HH				
17	99-4204	1	Hose-Cleaner, Air				
18	3296-29	2	Nut-Lock				
19	2412-92	2	Clamp-Hose				
20	93-8069	1	Decal-Surface, Hot				
21	93-7275	1	Decal-Fluid, Starting				
22	92-9283	1	Hose-Vent, Fuel				
24	92-2379	2	Clamp-Hose				
25	93-5553	1	Hose - Fuel				
26	33114-080	2	Screw-HH				
27	99-9179	1	Gasket-Exhaust				

* Not illustrated

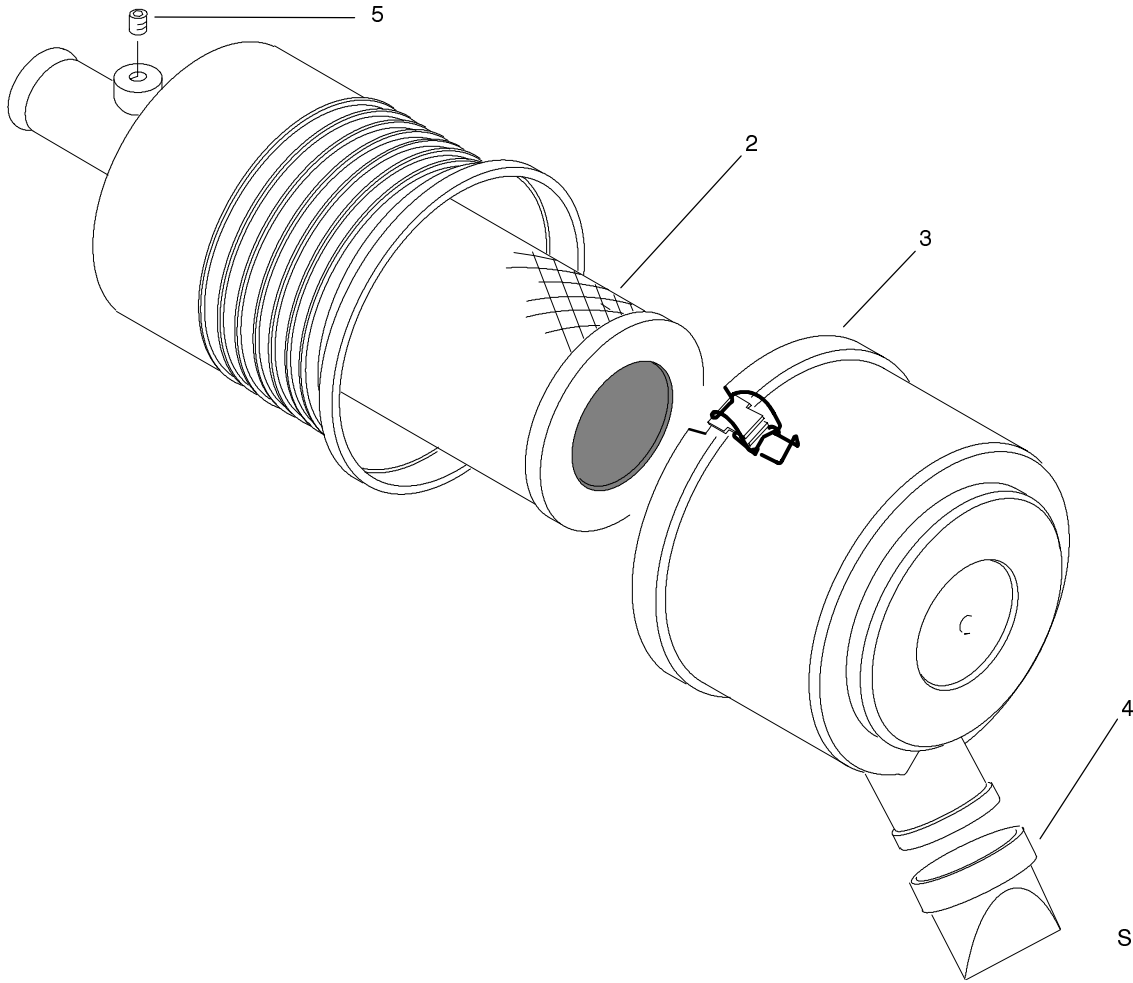

Sheet No.:A8
T-2607

Air Cleaner Assembly No. 95-5805

Ref. No.	Part No.	Qty.	Description
2	93-2195	1	Filter
3	94-3652	1	Cover ASM
4	94-1414	1	Valve - Vacuator
5	285-17	1	Plug-Pipe

Ref. No.	Part No.	Qty.	Description

PROTOTYPE

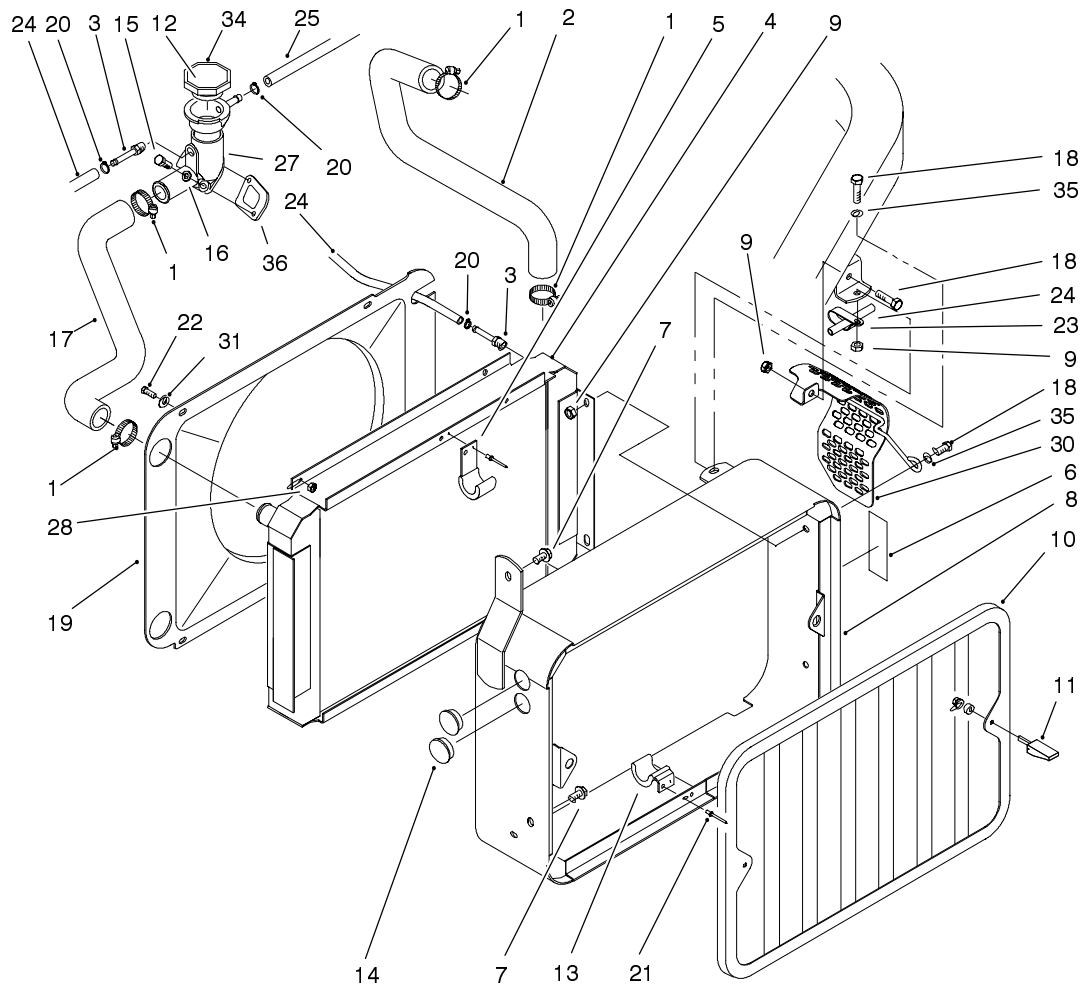

Sheet No.:15

Radiator Assembly

Ref. No.	Part No.	Qty.	Description	Ref. No.	Part No.	Qty.	Description
1	2412-34	4	Clamp-Hose	27	93-2448	1	Thermostat Housing ASM
2	99-1469	1	Hose - Radiator	28	33023-00	4	Nut-Lock
3	304-73	2	Connector-Hose	30	100-3164-03	1	Guard-Alternator
4	99-8193	1	Radiator	31	3256-22	4	Washer-Flat
5	93-2425	2	Bracket-Cooler, Upper	34	66-3240	1	Cap-Radiator
6	93-6681	1	Decal-Warning, Fan	35	3256-23	2	Washer-Flat
7	32144-14	2	Screw-HWH	36	99-9163	1	Gasket-Outlet
8	100-3163-01	1	Radiator Support ASM				
9	33024-00	6	Nut-Lock				
10	93-2050-03	1	Screen				
11	74-5950	2	Latch-Swell				
12	93-7840	1	Decal-Cap, Radiator				
13	93-2424	2	Bracket-Cooler, Lower				
14	94-4528	2	Plug				
15	33113-025	2	Screw-HH				
16	3253-3	2	Washer-Lock/Sp				
17	93-2018	1	Hose - Radiator				
18	33114-020	6	Screw-HH				
19	93-2320	1	Shroud-Fan				
20	2412-108	3	Clamp-Worm				
21	3269-15	8	Rivet				
22	33113-016	4	Screw-HH				
23	92-5753	1	Clamp-Hose				
24	27-4480	1	Hose				
25	92-9283	1	Hose-Vent, Fuel				

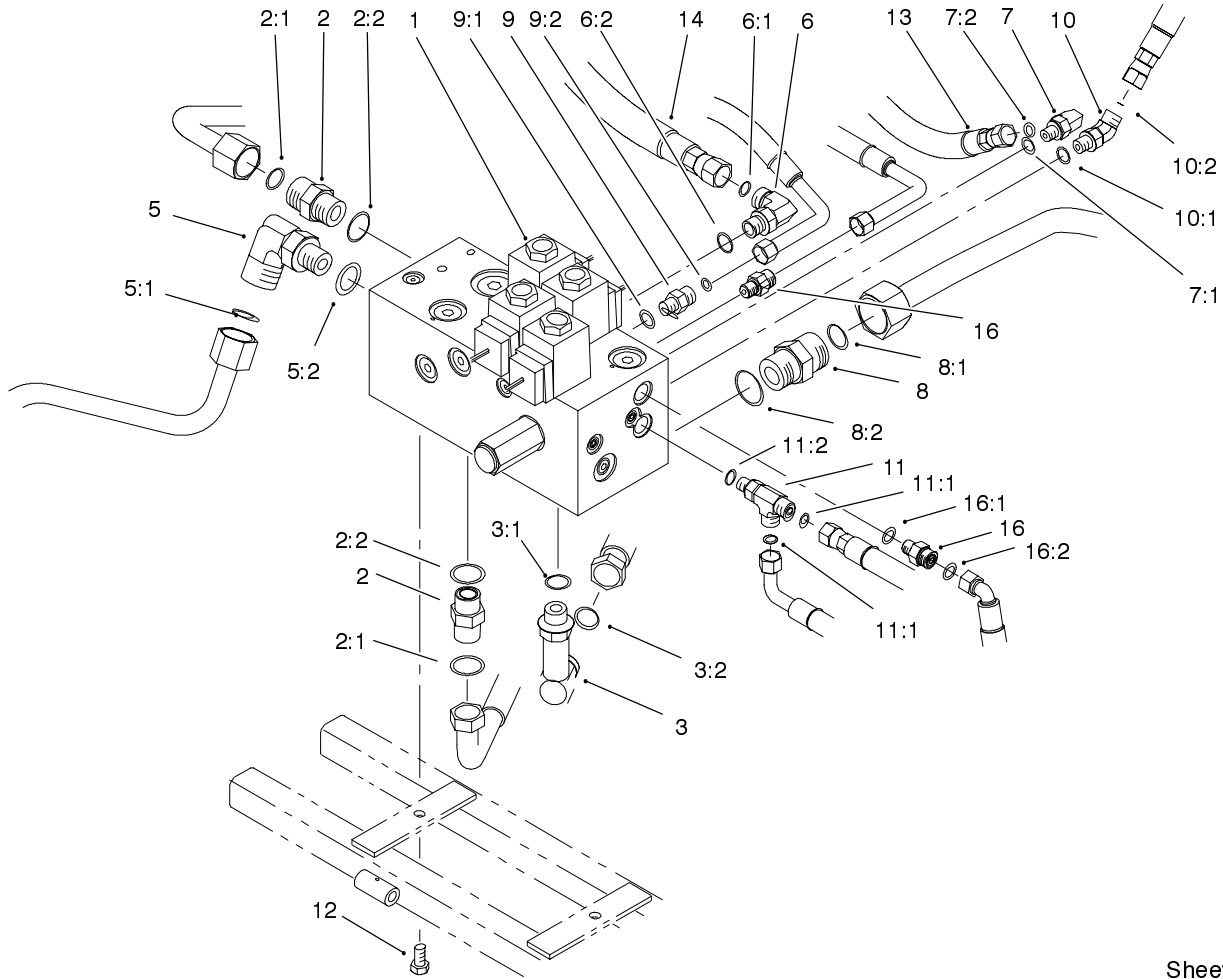

Sheet No.:16

Manifold Block Installation Assembly

Ref. No.	Part No.	Qty.	Description
1	93-2240	1	Manifold-Mow/Lift, Basic
2	340-7	2	Adapter
2:1	237-65	1	O-Ring
2:2	237-80	1	O-Ring
3	99-4214	1	Fitting-Hydraulic
3:1	237-79	1	O-Ring
3:2	237-30	1	O-Ring
5	340-17	1	Adapter
5:1	237-65	1	O-Ring
5:2	237-80	1	O-Ring
6	340-77	1	Fitting-90°
6:1	237-22	1	O-Ring
6:2	237-42	1	O-Ring
7	340-132	1	Elbow-90°
7:1	237-78	1	O-Ring
7:2	237-21	1	O-Ring
8	340-9	1	Fitting-Straight
8:1	237-58	1	O-Ring
8:2	237-81	1	O-Ring
9	340-92	1	Fitting
9:1	237-78	1	O-Ring
9:2	237-21	1	O-Ring
10	340-103	1	Fitting
10:1	237-78	1	O-Ring
10:2	237-21	1	O-Ring

Ref. No.	Part No.	Qty.	Description
11	340-140	1	Adapter Tee
11:1	237-21	2	O-Ring
11:2	237-78	1	O-Ring
12	33114-016	2	Screw-HH
13	93-2271	1	Hydraulic Hose ASM
14	93-2272	1	Hydraulic Hose ASM
16	95-1639	2	Fitting - Orificed
16:1	237-78	1	O-Ring
16:2	237-21	1	O-Ring

PROTOTYPE

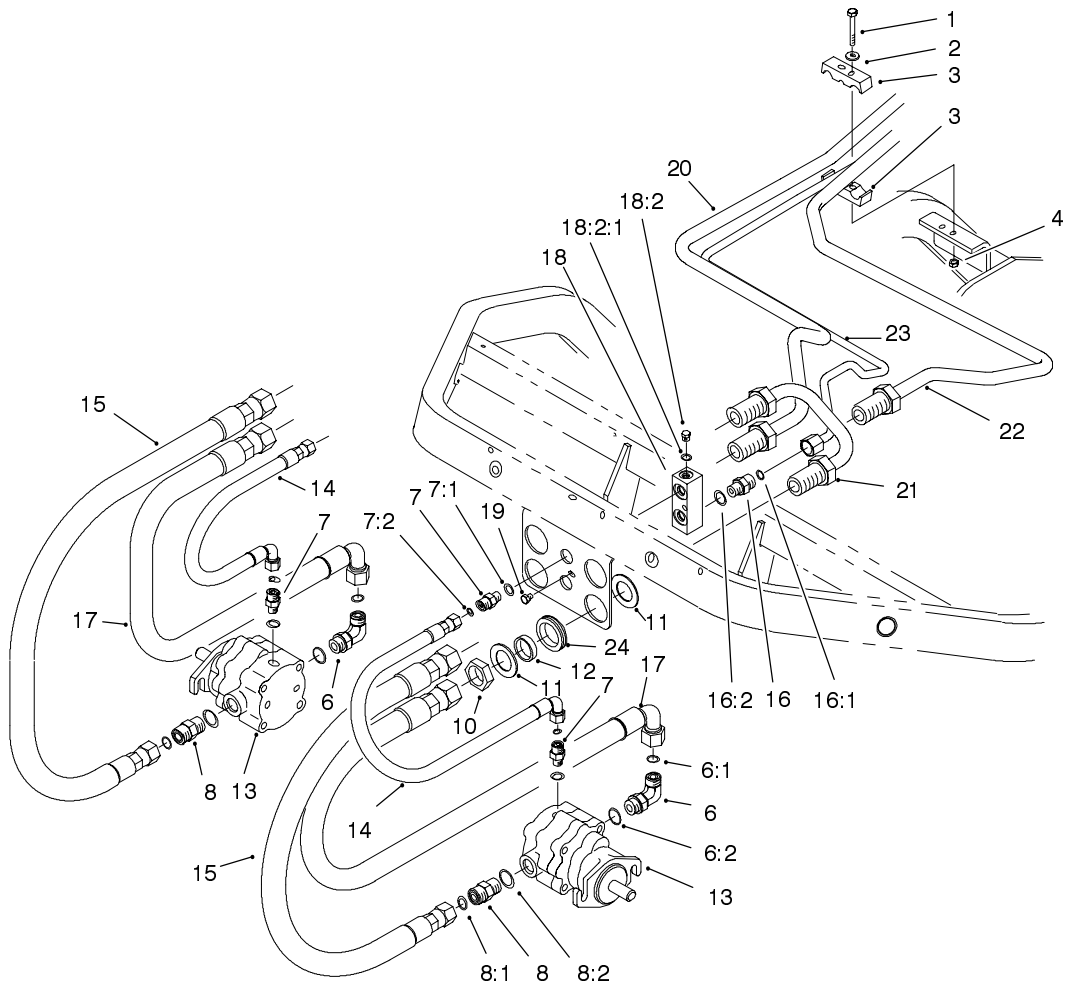

Sheet No.:17

Front Bulkhead and Reel Motor Assembly

Ref. No.	Part No.	Qty.	Description
1	33113-050	2	Screw-HH
2	3256-1	2	Washer-Flat
3	93-2509	2	Clamp - Tube
4	33023-00	2	Nut-Lock
6	340-98	2	Fitting-90°
6:1	237-79	1	O-Ring
6:2	237-30	1	O-Ring
7	340-92	4	Fitting
7:1	237-78	2	O-Ring
7:2	237-21	2	O-Ring
8	340-4	2	Adapter
8:1	237-30	1	O-Ring
8:2	237-79	1	O-Ring
10	340-74	2	Locknut-Bulkhead
11	69-9010	4	Washer
12	69-9000	2	Spacer
13	93-1375	2	Motor-Reel
14	93-2264	2	Hydraulic Hose ASM
15	95-2908	2	Hose ASM
16	340-2	1	Adapter
16:1	237-22	1	O-Ring
16:2	237-42	1	O-Ring
17	95-2909	2	Hose ASM
18	93-2238	1	T-Block
18:2	353-991	1	Plug-Hex, Hollow
18:2:1	237-156	1	O-Ring

Ref. No.	Part No.	Qty.	Description
19	33113-008	1	Screw-HH
20	94-1318	1	Tube - Hydraulic
21	94-1319	1	Tube - Hydraulic
22	94-1320	1	Tube - Hydraulic
23	94-1321	1	Tube - Hydraulic
24	240-3	2	Grommet-Rubber

PROTOTYPE

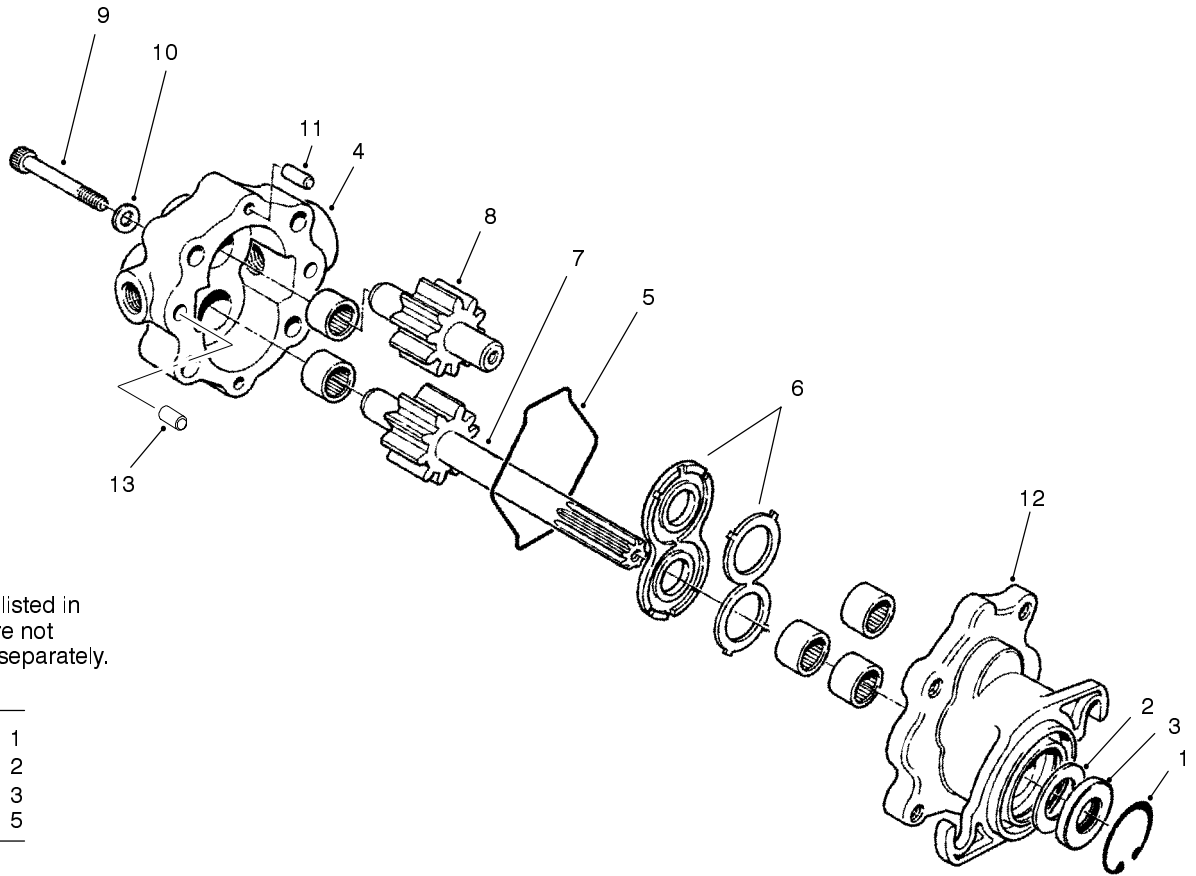

Parts not listed in partlist are not serviced separately.

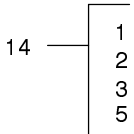

Sheet No.:B1
T-1872

Reel Motor Assembly No. 93-1375

Ref. No.	Part No.	Qty.	Description
1	32151-41	1	Ring-Snap
4	93-3614	1	Cover ASM
5	354-46	1	Ring-Seal
6	74-3810	1	Load Plate ASM
7	93-3615	1	Drive Shaft & Gear ASM
8	93-3616	1	Idler Shaft & Gear ASM
9	354-50	4	Screw-HSH
10	354-51	4	Washer
11	353-599	2	Pin-Dowel
12	92-8795	1	Body ASM
13	92-8796	2	Pin - Dowel
14	92-8863	1	Kit-Repair

Ref. No.	Part No.	Qty.	Description

PROTOTYPE

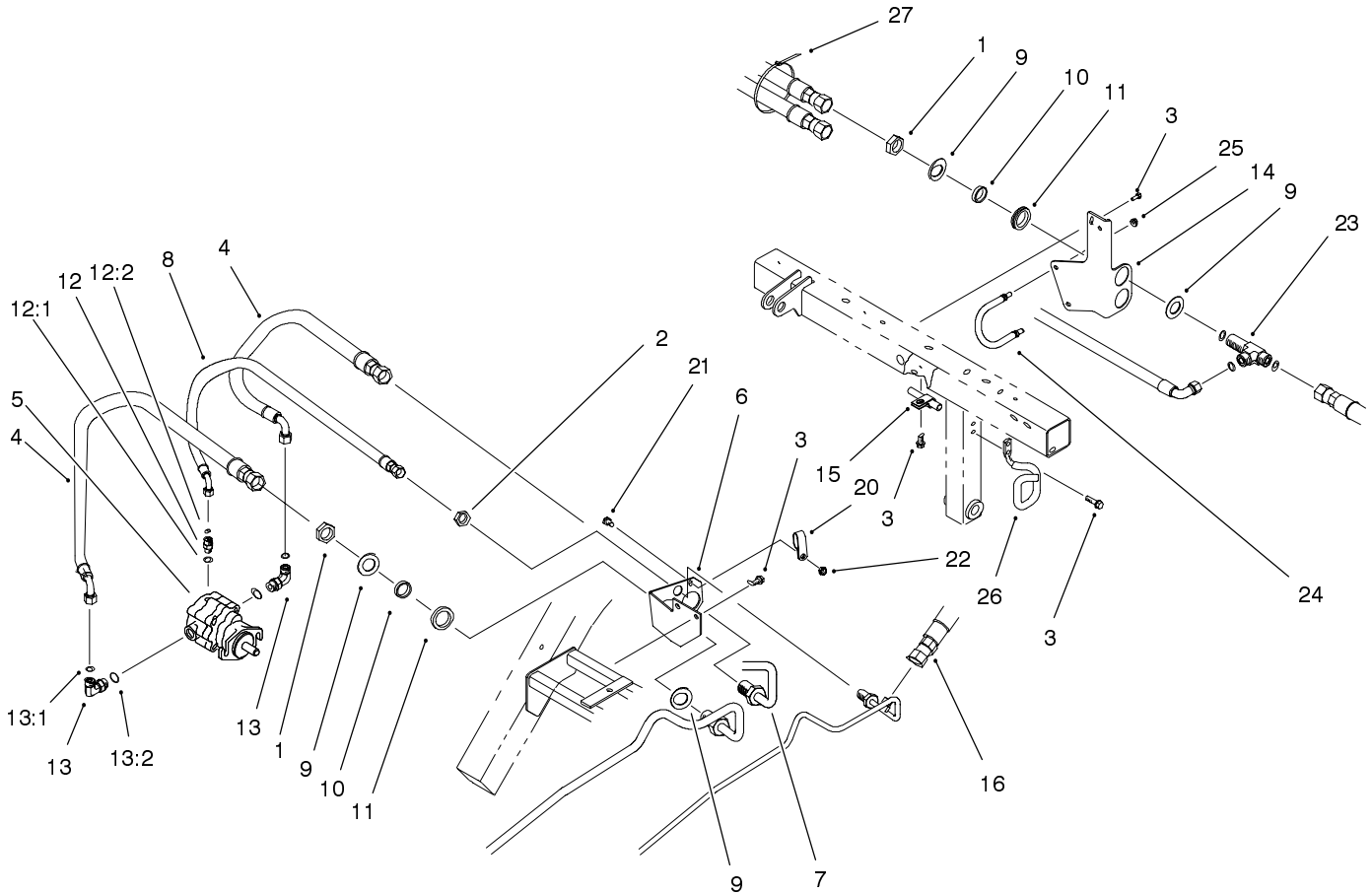

Sheet No.:18

Rear Bulkhead and Reel Motor Assembly

Ref. No.	Part No.	Qty.	Description
1	340-74	4	Locknut-Bulkhead
2	340-70	1	Locknut-Bulkhead
3	32144-14	7	Screw-HWH
4	95-2907	2	Hose ASM
5	93-1375	1	Motor-Reel
6	94-1316	1	Bracket - Bulkhead
7	94-1317	1	Tube - Hydraulic
8	94-1328	1	Hose ASM
9	69-9010	8	Washer
10	69-9000	4	Spacer
11	240-3	4	Grommet-Rubber
12	340-92	1	Fitting
12:1	237-78	1	O-Ring
12:2	237-21	1	O-Ring
13	340-98	2	Fitting-90°
13:1	237-79	1	O-Ring
13:2	237-30	1	O-Ring
14	99-4222-03	1	Bracket-Hose
15	2412-4	1	Clamp
16	94-4539	1	Hose ASM
20	2412-137	1	Clamp-Tube
21	33114-020	1	Screw-HH
22	33024-00	1	Nut-Lock
23	94-5350	2	Tee-Bulkhead, Ors
24	99-4221	1	Retainer-Hose
25	3296-29	2	Nut-Lock

Ref. No.	Part No.	Qty.	Description
26	94-5352	1	Retainer - Hose
27	3290-378	1	Tie-Cable

PROTOTYPE

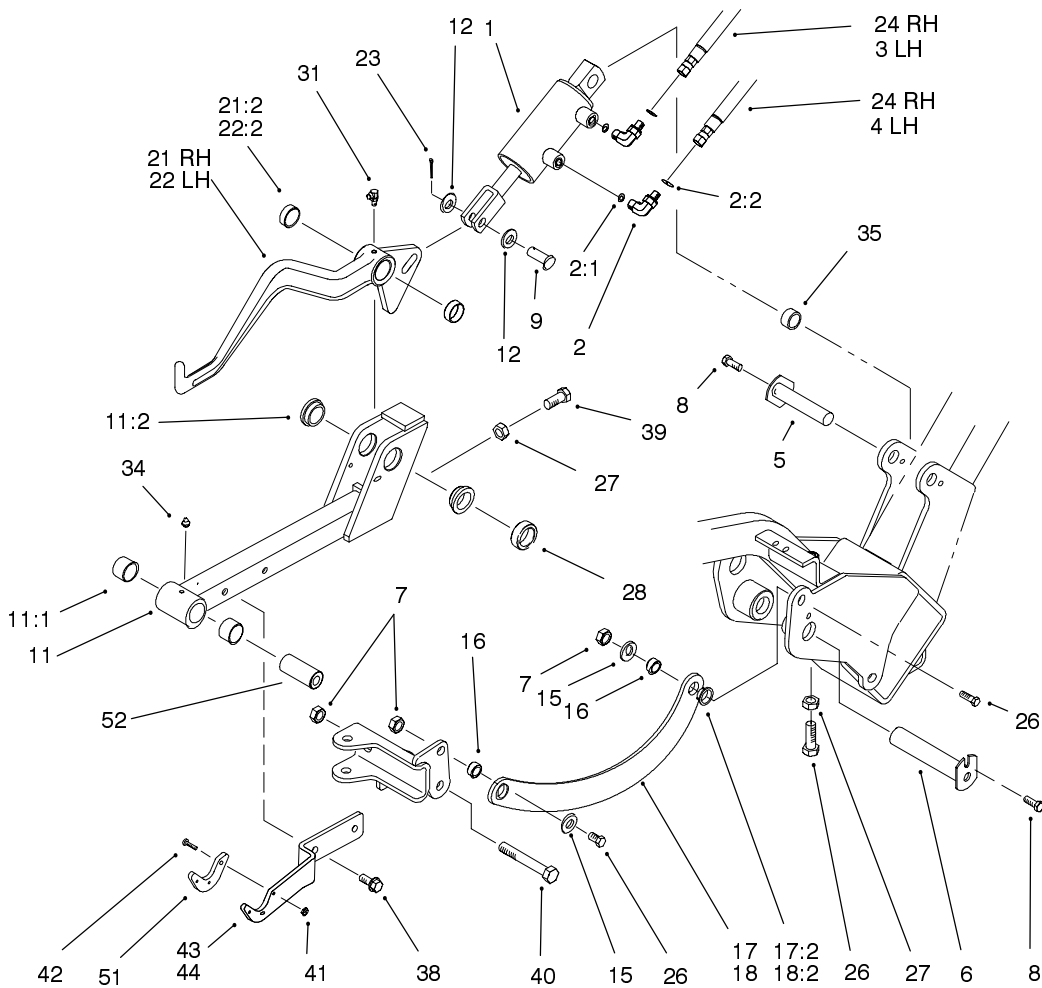

Sheet No.:19

LH and RH Lift Arm Assembly

Ref. No.	Part No.	Qty.	Description
1	99-4263	2	Hydraulic Cylinder ASM
*1:1	99-8163	1	Kit-Repair, Seal
2	340-132	4	Elbow-90°
2:1	237-78	1	O-Ring
2:2	237-21	1	O-Ring
3	93-2255	1	Hydraulic Hose ASM
4	93-2256	1	Hydraulic Hose ASM
5	10-6060	2	Pin-Pivot, Ram
6	94-8198	2	Pin
7	3296-25	6	Nut-Lock NI
8	32144-14	4	Screw-HWH
9	283-68	2	Pin-Clevis
11	99-4115	2	Front Lift Frame ASM
11:1	98-4166	2	Bushing
11:2	94-9610	2	Bushing - Flange
12	33096-00	4	Washer-Flat
15	3256-26	4	Washer-Flat
16	99-4201	4	Tube-Spacer
17	99-4258	1	RH Link Bracket ASM
17:2	99-4243	2	Bushing-Flange
18	99-4260	1	LH Link Bracket ASM
18:2	99-4243	2	Bushing-Flange
21	99-4213	1	RH Lift Arm ASM
21:2	92-8995	2	Bushing
22	99-4212	1	LH Lift Arm ASM

Ref. No.	Part No.	Qty.	Description
22:2	92-8995	2	Bushing
23	3272-11	2	Pin-Cotter
24	93-2254	2	Hydraulic Hose ASM
26	325-6	5	Screw-HH
27	3218-5	3	Nut-Jam
28	93-2384	2	Spacer-Carrier
31	302-60	2	Fitting-Lube
34	302-5	2	Fitting - Grease
35	74-3730	2	Spacer-Spindle, Rear
38	32144-69	4	Screw-HH
39	325-4	2	Screw-HH
40	325-14	2	Screw-HH
41	3296-54	6	Nut-Lock NI
42	3250-17	6	Screw-PPH
43	99-4111-01	1	Plate-Transport
44	99-4112-01	1	Plate-Transport
51	99-4225	2	Pad-Wear
52	99-4072	2	Spacer-Frame, Pull

* Not illustrated

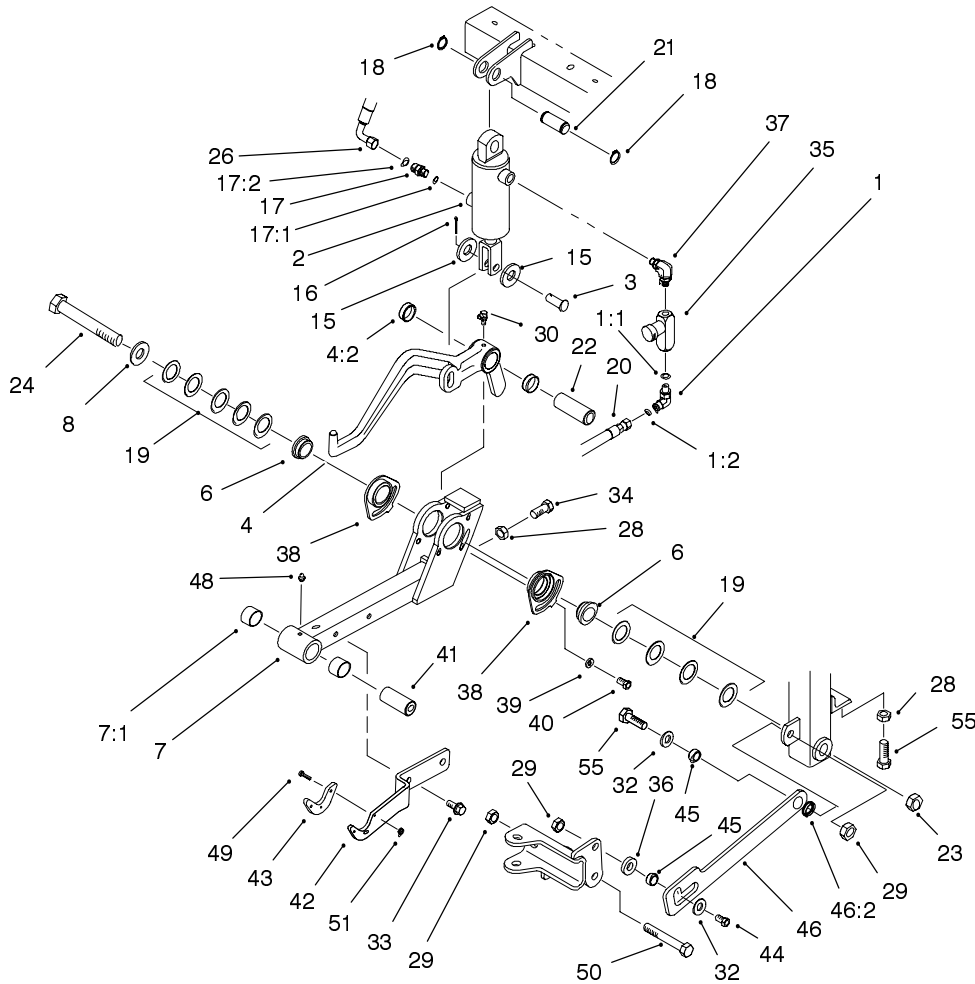

Sheet No.:20

Center Lift Arm Assembly

Ref. No.	Part No.	Qty.	Description
1	340-132	1	Elbow-90°
1:1	237-78	1	O-Ring
1:2	237-21	1	O-Ring
2	99-4262	1	Hydraulic Cylinder ASM
*2:1	99-8163	1	Kit-Repair, Seal
3	283-68	1	Pin-Clevis
4	99-4126	1	Center Lift Arm ASM
4:2	92-8995	2	Bushing
6	98-2197	2	Bushing - Flange
7	99-4116	1	Rear Lift Frame ASM
7:1	98-4166	2	Bushing
8	69-8940	1	Washer
15	33096-00	2	Washer-Flat
16	3272-11	1	Pin-Cotter
17	95-1639	1	Fitting - Orificed
17:1	237-78	1	O-Ring
17:2	237-21	1	O-Ring
18	32120-72	2	Ring-Snap
19	63-2290	9	Washer-Thrust
20	93-2258	1	Hydraulic Hose ASM
21	94-3452	1	Pin
22	94-8199	1	Tube-Pivot
23	3296-53	1	Nut-Lock NI
24	327-19	1	Screw-HH
26	94-3477	1	Hydraulic Hose ASM

Ref. No.	Part No.	Qty.	Description
28	3218-5	2	Nut-Jam
29	3296-25	3	Nut-Lock NI
30	302-60	1	Fitting-Lube
32	3256-26	2	Washer-Flat
33	32144-69	2	Screw-HH
34	325-5	1	Screw-HH
35	93-7489	1	Orifice Valve ASM
36	99-4248	1	Spacer
37	95-2927	1	Fitting - Elbow
38	98-4618	2	Bushing - Eccentric
39	3256-74	2	Washer-Flat
40	33114-016	2	Screw-HH
41	99-4072	1	Spacer-Frame, Pull
42	99-4111-01	1	Plate-Transport
43	99-4225	1	Pad-Wear
44	325-7	1	Screw-HH
45	99-4201	2	Tube-Spacer
46	99-4246	1	Link Bracket ASM
46:2	99-4243	1	Bushing-Flange
48	302-5	1	Fitting - Grease
49	3250-17	3	Screw-PPH
50	325-14	1	Screw-HH
51	3296-54	3	Nut-Lock NI
55	325-6	2	Screw-HH

* Not illustrated

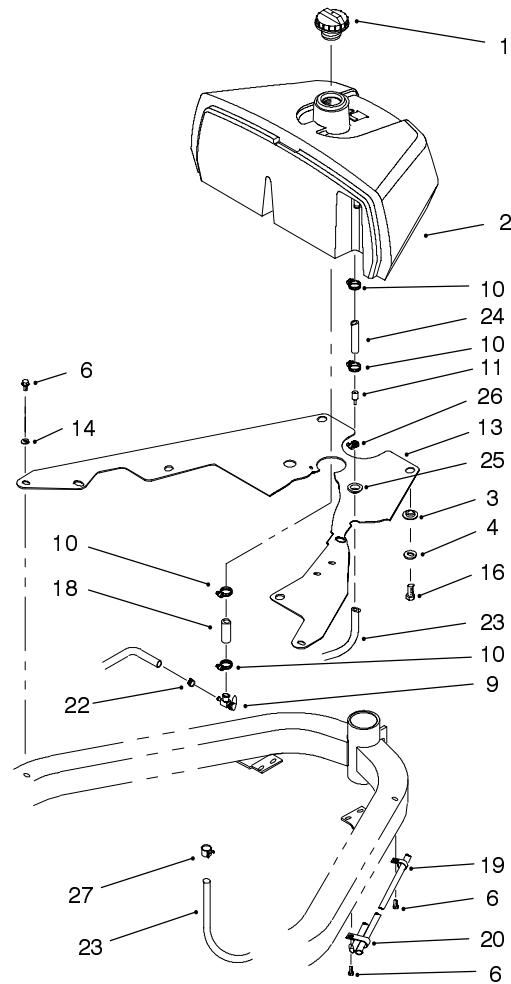

Sheet No.:21

Fuel System Assembly

Ref. No.	Part No.	Qty.	Description	Ref. No.	Part No.	Qty.	Description
1	93-3102	1	Cap-Fuel				
2	93-2225	1	Tank - Fuel				
3	240-11	3	Grommet-Mount, Tank				
4	93-4637	3	Washer - Flat				
6	32144-14	5	Screw-HWH				
9	56-2520	1	Fitting-Shut Off, Fuel				
10	2412-36	4	Clamp-Hose				
11	93-2299	1	Fitting - Fuel				
13	94-1364-03	1	Plate				
14	3256-23	2	Washer-Flat				
16	33115-020	3	Screw-HH				
18	94-4353	1	Hose-Line, Fuel				
19	2412-41	1	Clamp				
20	92-5753	1	Clamp-Hose				
22	92-2379	1	Clamp-Hose				
23	93-2298	1	Hose - Fuel				
24	56-2230	1	Hose-Fuel				
25	237-124	1	Grommet				
26	2412-108	1	Clamp-Worm				
27	94-8189	1	Clamp-Hose				

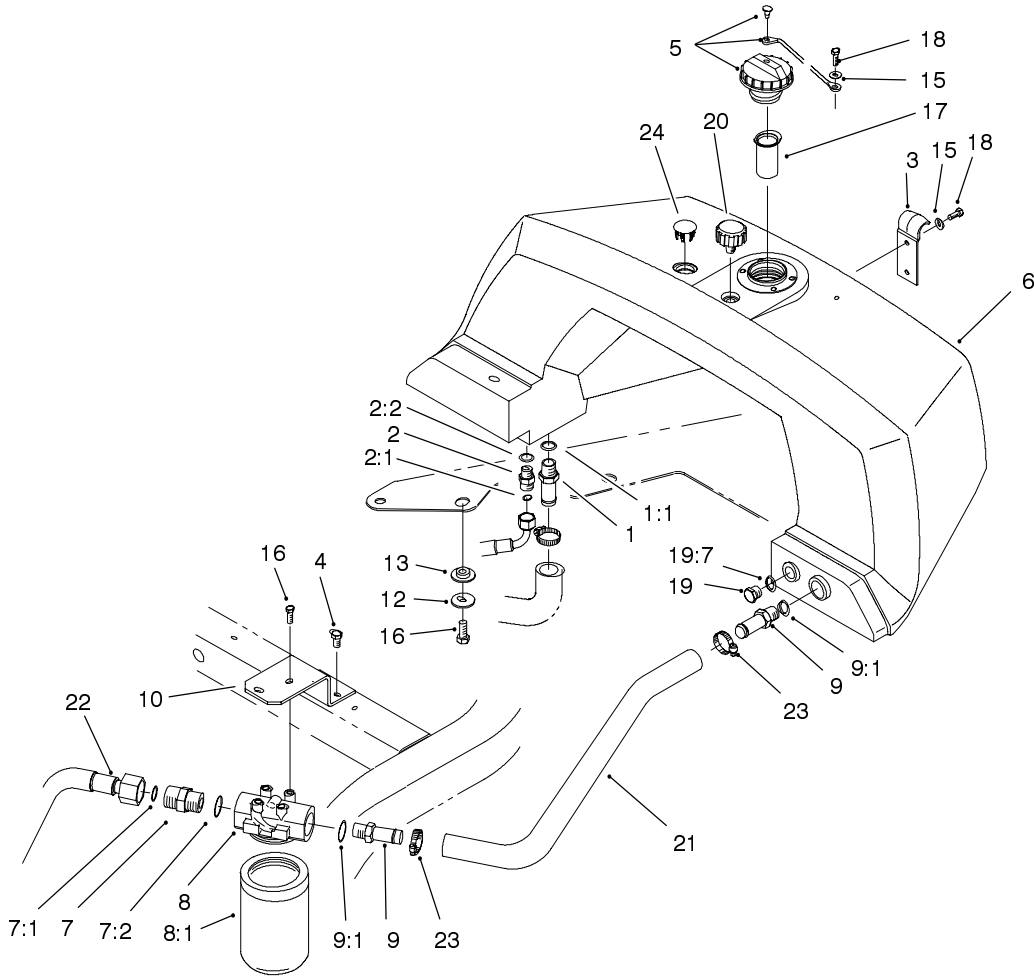

Sheet No.:22

Hydraulic Tank and Filter Assembly

Ref. No.	Part No.	Qty.	Description
1	354-78	1	Connector-Hose
1:1	237-146	1	O-Ring
2	340-2	1	Adapter
2:1	237-22	1	O-Ring
2:2	237-42	1	O-Ring
3	93-2438	1	Clamp-Tank, Fuel
4	32144-14	2	Screw-HWH
5	93-7160	1	Cap-Oil, Hydraulic
6	93-2235	1	Tank-Hydraulic
7	340-9	1	Fitting-Straight
7:1	237-58	1	O-Ring
7:2	237-81	1	O-Ring
8	93-2242	1	Oil Filter ASM
8:1	75-1310	1	Filter Element
9	354-73	2	Fitting
9:1	237-81	2	O-Ring
10	93-2236-03	1	Mount-Filter, Oil
12	93-4637	4	Washer - Flat
13	240-11	4	Grommet-Mount, Tank
15	3256-1	3	Washer-Flat
16	33115-020	4	Screw-HH
17	93-2275	1	Screen - Filler
18	33113-016	3	Screw-HH
19	353-988	1	Plug-Hex, Hollow
19:7	237-79	1	O-Ring

Ref. No.	Part No.	Qty.	Description
20	68-6150	1	Breather-Air
21	94-9607	1	Hose - Return
22	94-4518	1	Tube ASM
23	2412-129	2	Clamp-Hose
24	93-2437	1	Plug - Serrated

PROTOTYPE

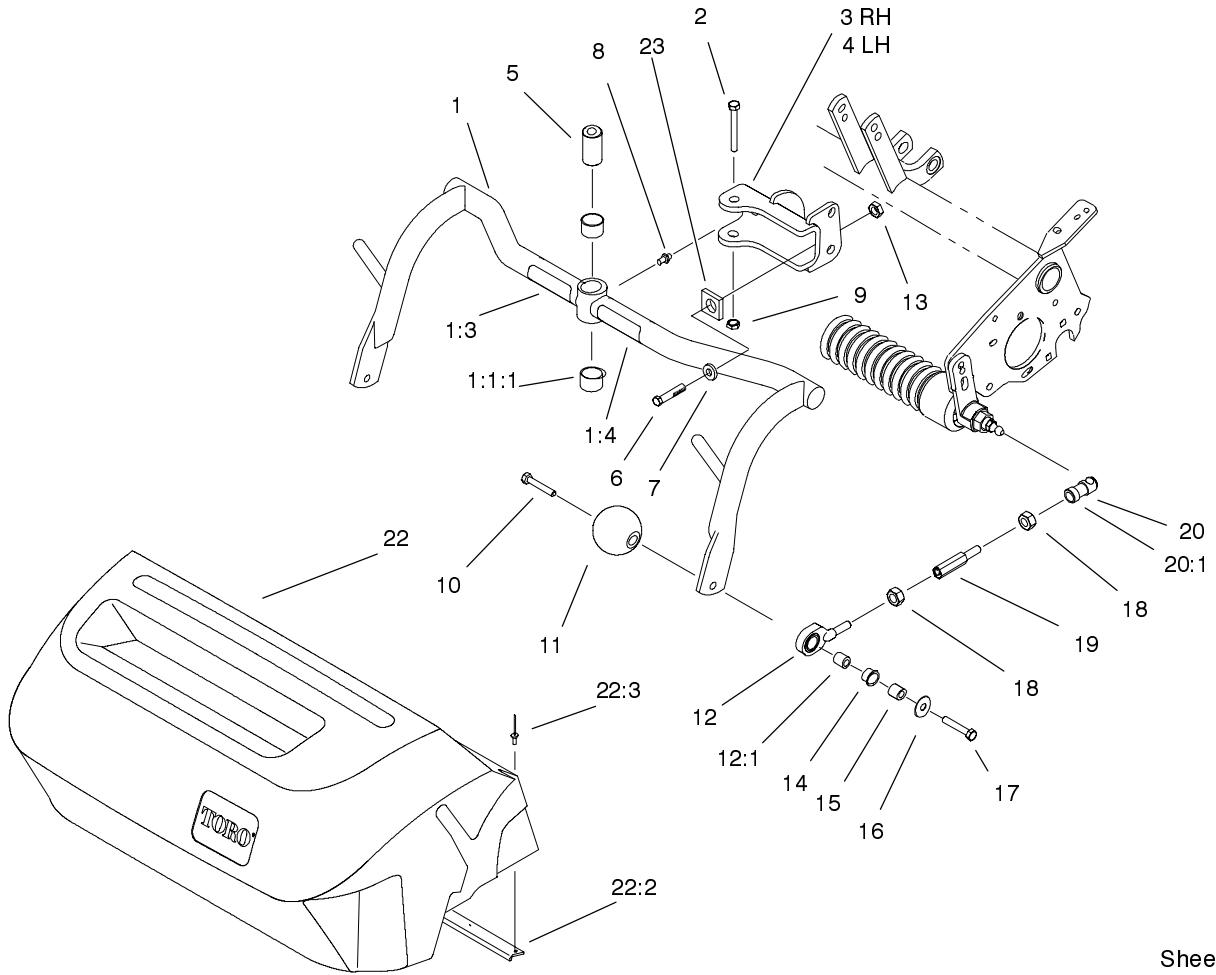

Sheet No.:30

Center Pull Frame Assembly

Ref. No.	Part No.	Qty.	Description
1	99-4114	3	Pull Frame ASM
1:1		1	Pull Frame ASM
1:1:1	98-4166	2	Bushing
1:3	94-2575	1	Decal-Adjustment
1:4	99-4118	1	Decal-Danger
2	325-13	3	Screw-HH
3	99-4183-01	2	RH Clevis ASM
4	99-4182-01	1	LH Clevis ASM
5	99-4109	3	Spacer-Pivot
6	78-8710	3	Screw
7	3256-77	3	Washer-Flat
8	302-5	3	Fitting - Grease
9	3296-25	3	Nut-Lock NI
10	99-4209	6	Shaft-Roller
11	99-4210	6	Roller-Anti Scalp
12	100-6440	6	Pull Link And Bushing ASM
12:1	95-0532	1	Rubber Bushing ASM
13	3296-12	3	Nut-Lock
14	256-292	6	Bushing-Flange, NI
15	75-5270	6	Spacer-Knob, Seat
16	80-6990	6	Washer-Hardened
17	323-8	6	Screw-HH
18	3220-3	12	Nut-Jam
19	88-6870	6	Extension-Arm, Pull

Ref. No.	Part No.	Qty.	Description
20	99-1460	6	Ball Joint Receiver ASM
20:1	99-1461	1	Sleeve-Joint, Ball
22	104-2071	3	Basket ASM
22:2	104-2607	1	Strip-Basket
22:3	3290-382	8	Rivet-Pop
23	94-1392	3	Pad - Rubber

Electrical Schematic

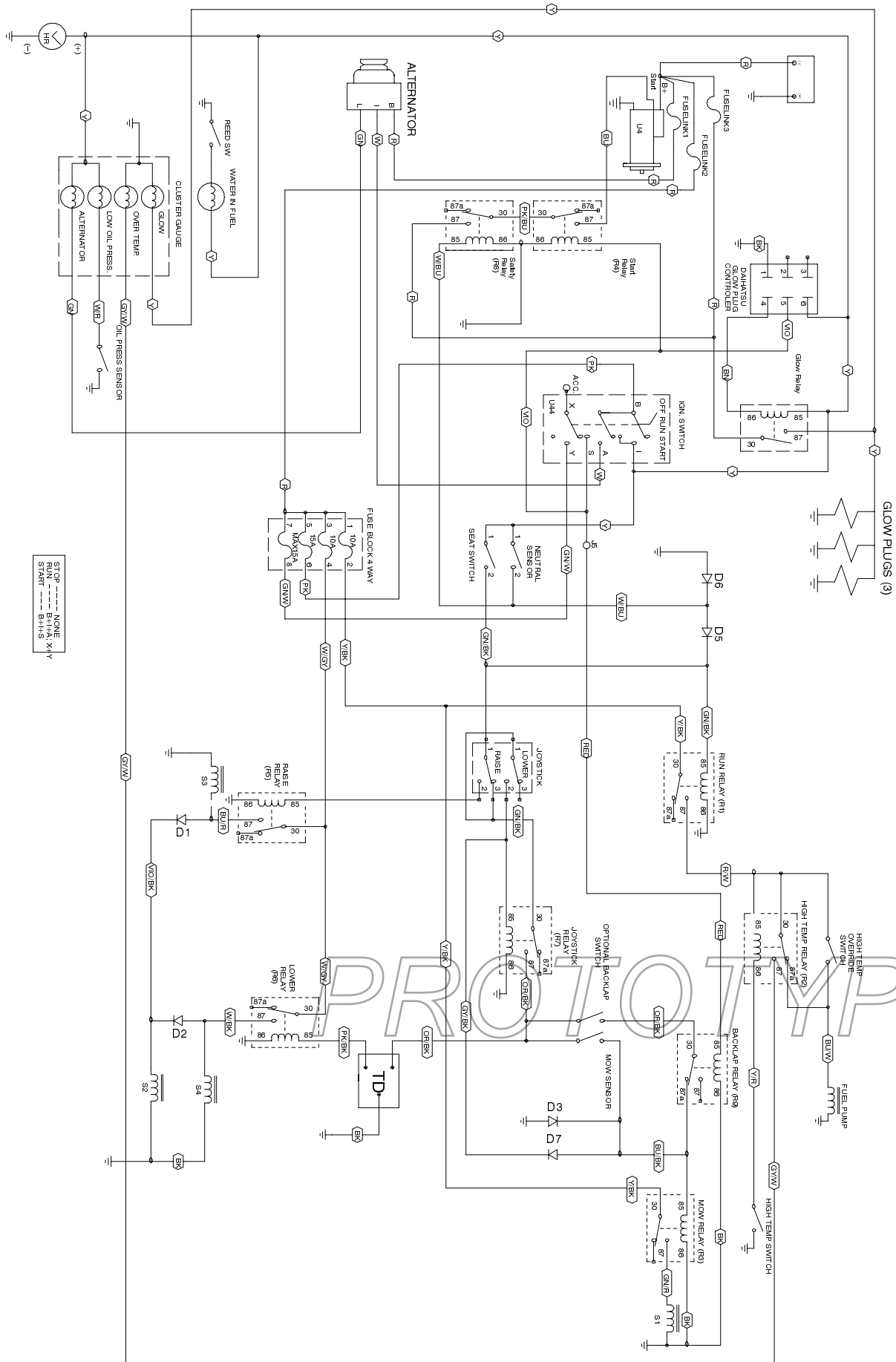

STOP NONE
RUN SH14 X14
START SH14 S

Hydraulic Schematic

DISPLACEMENT, FLOW RATE AND PRESSURE CHART			
COMPONENT	DISPLACEMENT	PRESSURE	FLOW RATE
	in ³ /rev	lbs/in ² BARS	GPM LPM
P1	.58	9.5	5.9 22.4
P2	.31	5.1	3.7 13.9
P3	1.24	20.3	14.8 55.8
M1	.73	12.0	-
M2	.73	12.0	-
M3	.73	12.0	-
M4	10.3	168.8	-
M5	10.3	168.8	-
V1	4.88	80	-
R1	-	2400	166
R2	-	150	10
R4	-	100	7
R5	-	1000	69

* * *

* FLOW RATE CALCULATED AT 2800 RPM AND 98% EFFICIENCY

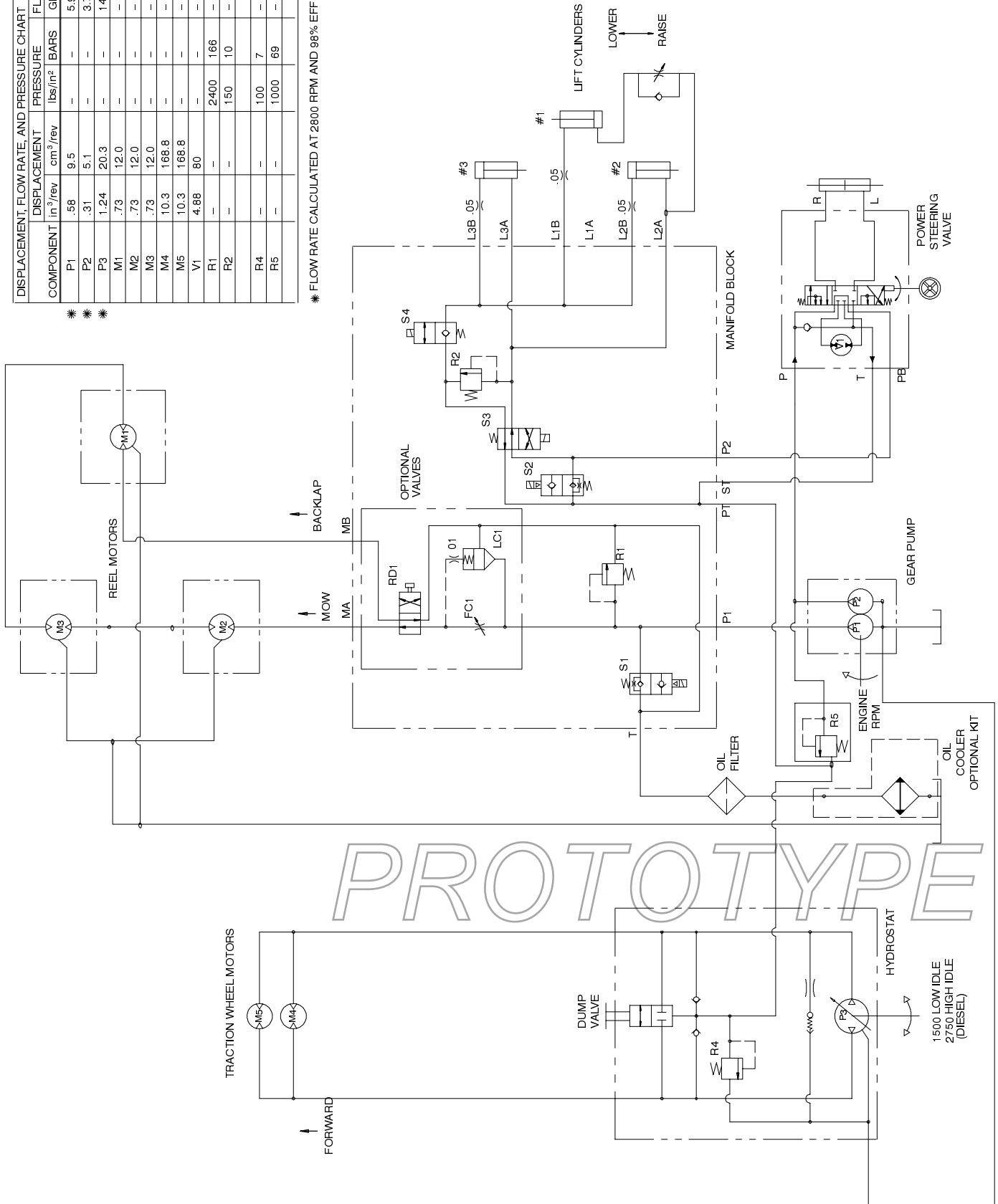

PROTOTYPE

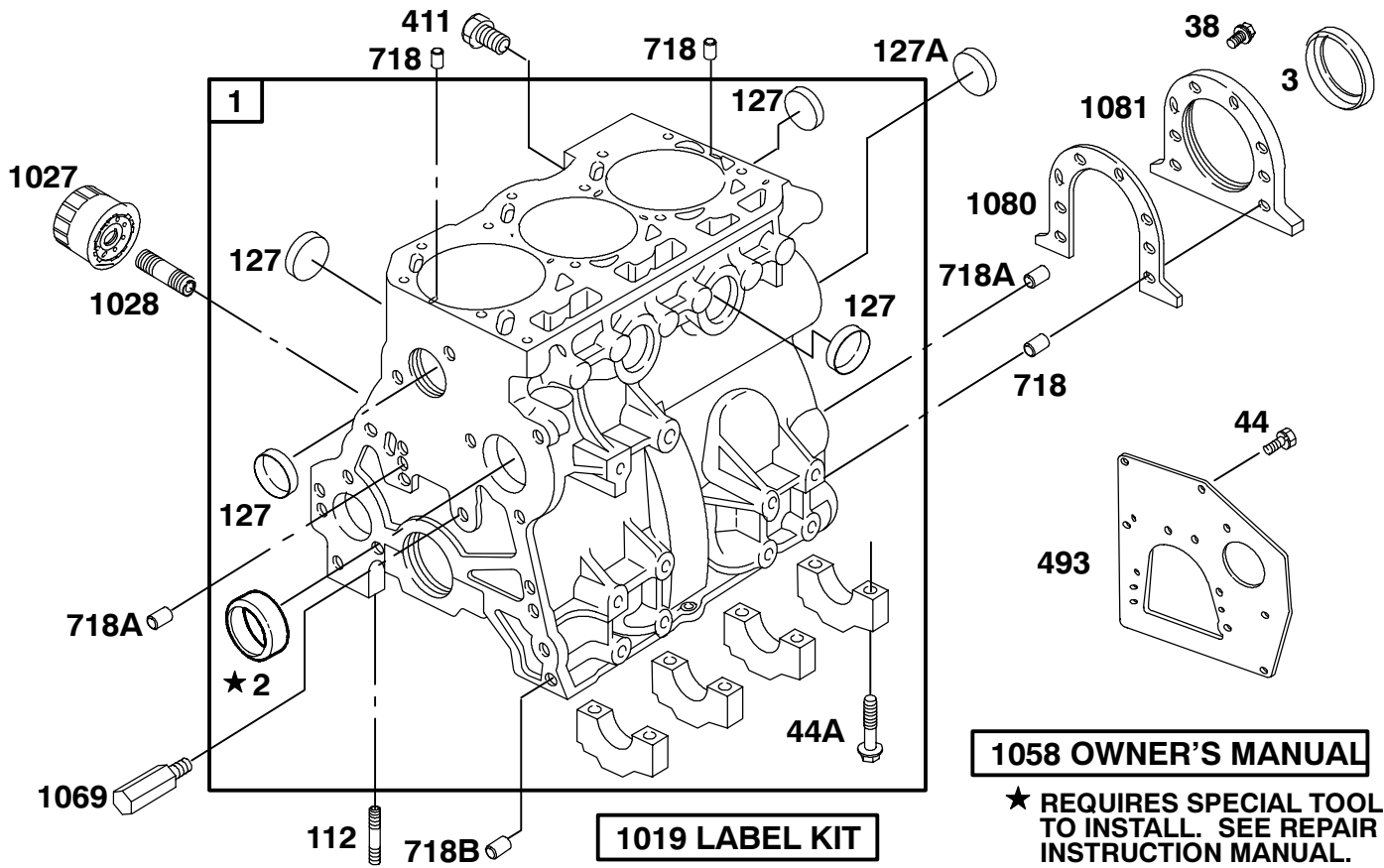

522447-0107-E2 TORO DIESEL

Ref. No.	Part No.	Qty.	Description	Ref. No.	Part No.	Qty.	Description
∇01	100-6401	1	Cylinder Assembly				
∇02	99-9002	1	Bushing				
★03	99-9003	1	Seal-Oil				
1019	99-9015	1	Label Kit				
1058	99-9602	1	Owner's Manual				
∇1069	99-9020	1	Nozzle-Oil				
★1080	99-9021	1	Gasket-Retainer				
∇1081	99-9022	1	Retainer-Seal				
112	99-9007	1	Stud-Metric				
1027	99-9017	1	Filter-Oil				
127	99-9008	7	Plug-Welch				
∇127A	99-9010	1	Plug-Welch (Camshaft)				
1028	99-9018	1	Adapter-Oil Filter				
38	99-9004	6	Screw-Hex				
∇411	99-9601	1	Plug (Cylinder Block)				
44	99-9005	3	Screw-Hex				
44A	99-9006	8	Screw-Hex				
∇493	100-3195	1	Bracket-Mounting				
718	99-9012	4	Pin-Locating				
718A	99-9013	3	Pin-Locating				
718B	99-9014	2	Pin-Locating				

∇ Refer To Repair Manual MS 1055 For Assembly and/or Torque Requirements.

★ Included in Gasket Set - Part Number 99-9667

△ Included in Valve Overhaul Kit - Part Number 99-9668

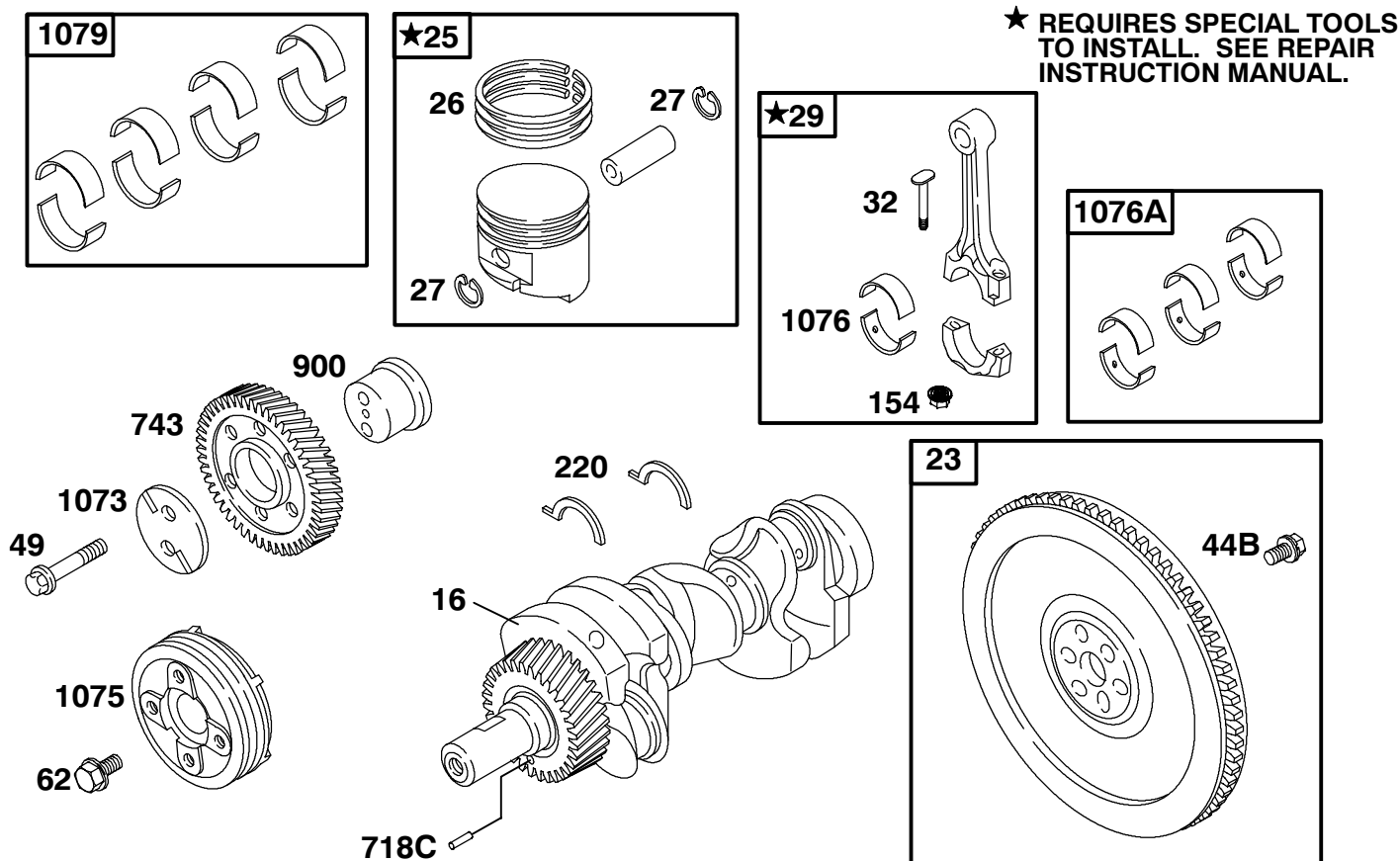

★ REQUIRES SPECIAL TOOLS TO INSTALL. SEE REPAIR INSTRUCTION MANUAL.

522447-0107-E2 TORO DIESEL

Ref. No.	Part No.	Qty.	Description	Ref. No.	Part No.	Qty.	Description
1073	99-9040	1	Plate-Idler Gear	718C	99-9037	1	Pin-Locating
1075	99-9692	1	Pully-Crankshaft	∇743	99-9609	1	Gear-Drive
∇1076	99-9042	1	Bearing-Rod	∇900	99-9039	1	Shaft-Gear
∇1076A	99-9043	3	Bearing Set-Rod				
∇1076A	99-9044	3	Bearing Set-Rod, .010 Undersize				
∇1079	99-9045	1	Bearing Set-Main				
∇1079	99-9046	1	Bearing Set-Main, .010 Under				
154	99-9034	6	Nut-Hex				
∇16	99-9252	1	Crankshaft				
∇220	99-9035	1	Washer-Thrust				
∇220	99-9036	1	Washer-Thrust .005" Oversize				
∇23	99-9267	1	Flywheel				
∇25	99-9605	3	Piston Assembly				
∇25	99-9268	3	Piston ASM				
∇26	99-9606	3	Ring Set				
∇26	99-9269	3	Ring Set				
27	99-9607	6	Lock-Piston Pin				
∇29	99-9608	3	Rod-Connecting				
∇32	99-9030	6	Screw-Connecting Rod				
44B	99-9031	6	Screw-10mm Hex				
49	99-9032	2	Screw-8mm Hex				
62	99-9033	1	Screw-Hex				

∇ Refer To Repair Manual MS 1055 For Assembly and/or Torque Requirements.

★ Included in Gasket Set - Part Number 99-9667

△ Included in Valve Overhaul Kit - Part Number 99-9668

Assemblies include all parts shown in frames.

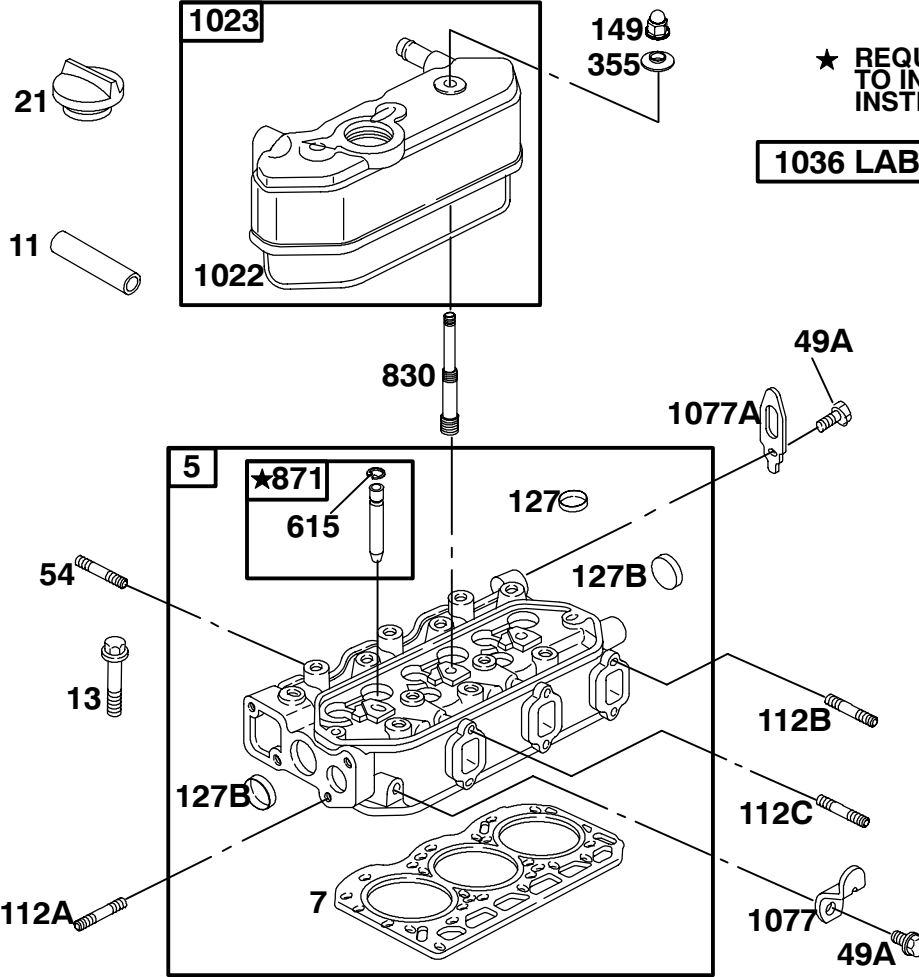

★ REQUIRES SPECIAL TOOLS TO INSTALL. SEE REPAIR INSTRUCTION MANUAL.

1036 LABEL KIT-EMISSION

522447-0107-E2 TORO DIESEL

Ref. No.	Part No.	Qty.	Description	Ref. No.	Part No.	Qty.	Description
∇05	99-9611	1	Head-Cylinder				
★Δ07	99-9612	1	Gasket-Cylinder Head				
★Δ1022	99-9073	1	Gasket-Rocker Cover				
1023	100-6402	1	Cover-Rocker				
1036	99-9615	1	Label Kit-Emission				
1077	99-9076	1	Bracket-Lifting				
1077A	99-9077	1	Bracket-Lifting				
11	99-9613	1	Tube-Breather				
112A	99-9057	2	Stud-Metric				
112C	99-9059	1	Stud-Metric				
112B	99-9058	5	Stud-Metric				
127	99-9008	2	Plug-Welch				
127B	99-9060	2	Plug-Welch				
13	99-9614	14	Screw-Metric				
149	99-9061	3	Nut-Metric Hex				
21	99-9052	1	Cap-Oil Fill				
★Δ355	99-9063	3	Washer-Seal				
49A	99-9054	2	Screw-8mm Hex				
54	99-9055	2	Stud-Metric				
615	99-9067	6	Retainer				
830	99-9101	3	Stud-Rocker Arm				
∇871	99-9070	6	Bushing-Guide				

PROTOTYPE

∇ Refer To Repair Manual MS 1055 For Assembly and/or Torque Requirements.

★ Included in Gasket Set - Part Number 99-9667

Δ Included in Valve Overhaul Kit - Part Number 99-9668

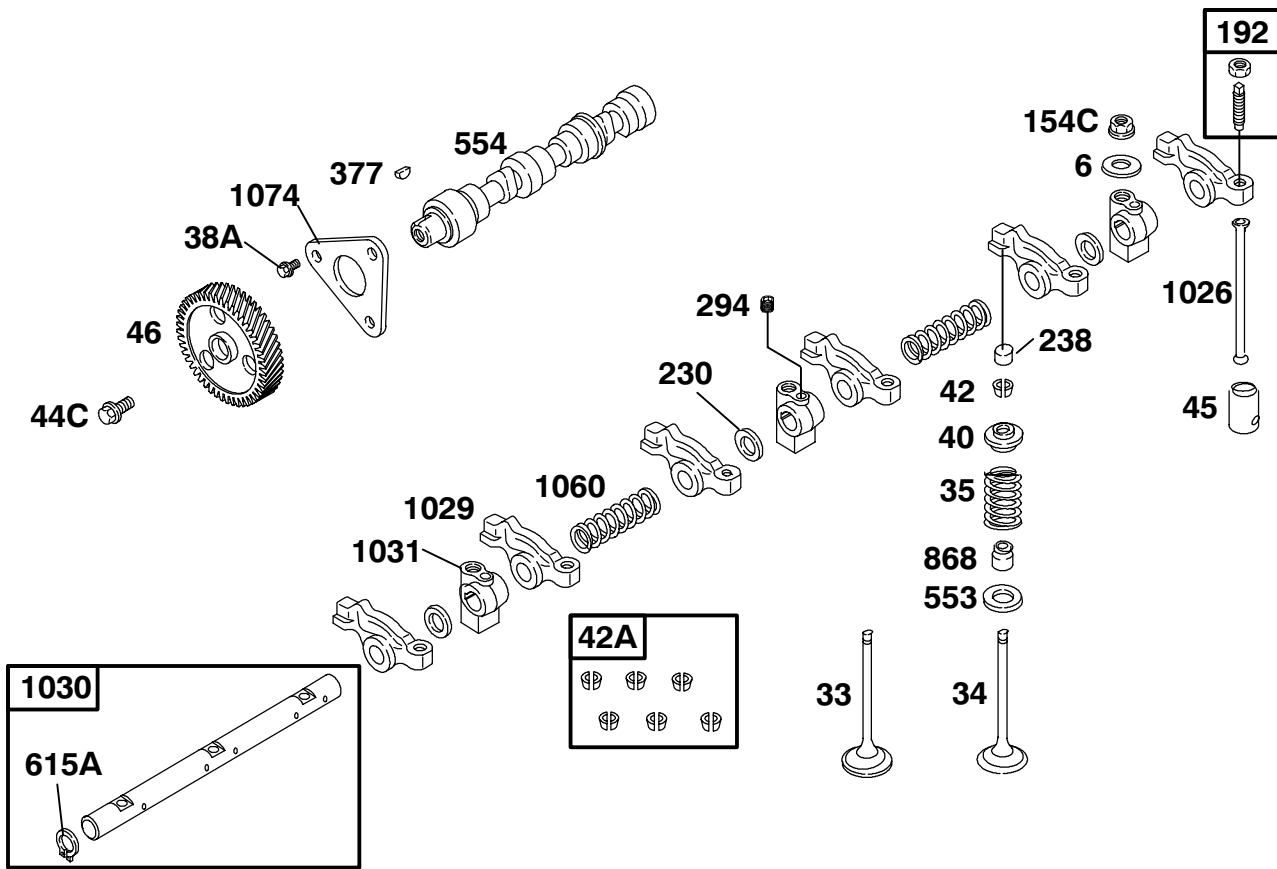

522447-0107-E2 TORO DIESEL

Ref. No.	Part No.	Qty.	Description	Ref. No.	Part No.	Qty.	Description
06	99-9079	3	Washer-Flat	615A	99-9099	2	Retainer
1026	99-9103	6	Rod-Push	★868	99-9643	6	Seal-Valve
▽1029	99-9104	1	Arm-Rocker				
▽1030	99-9106	1	Shaft-Rocker Arm				
▽1031	99-9107	3	Support-Rocker Arm				
▽1060	99-9108	2	Spring-Rocker Shaft				
1074	99-9109	1	Retainer-Camshaft				
154C	99-9091	3	Nut-Metric Hex				
192	99-9092	6	Adjuster-Rocker Arm				
▽230	99-9093	3	Washer-Spacer				
238	99-9094	6	Cap-Valve				
294	99-9090	1	Screw-Metric				
33	99-9638	3	Valve-Exhaust				
34	99-9639	3	Valve-Intake				
35	99-9640	6	Spring-Valve				
377	99-9642	1	Key-Timing				
38A	99-9083	3	Screw-6mm Hex				
40	99-9084	6	Retainer-Valve				
42	99-9086	1	Keeper-Valve				
42A	99-9087	6	Keeper-Valve (Set Of 6)				
44C	99-9085	1	Screw-Metric				
45	99-9088	6	Tappet-Valve				
▽46	99-9641	1	Gear-Cam				
553	99-9096	6	Seat-Valve Spring				
554	99-9097	1	Shaft-Cam				

▽ Refer To Repair Manual MS 1055 For Assembly and/or Torque Requirements.

★ Included in Gasket Set - Part Number 99-9667

△ Included in Valve Overhaul Kit - Part Number 99-9668

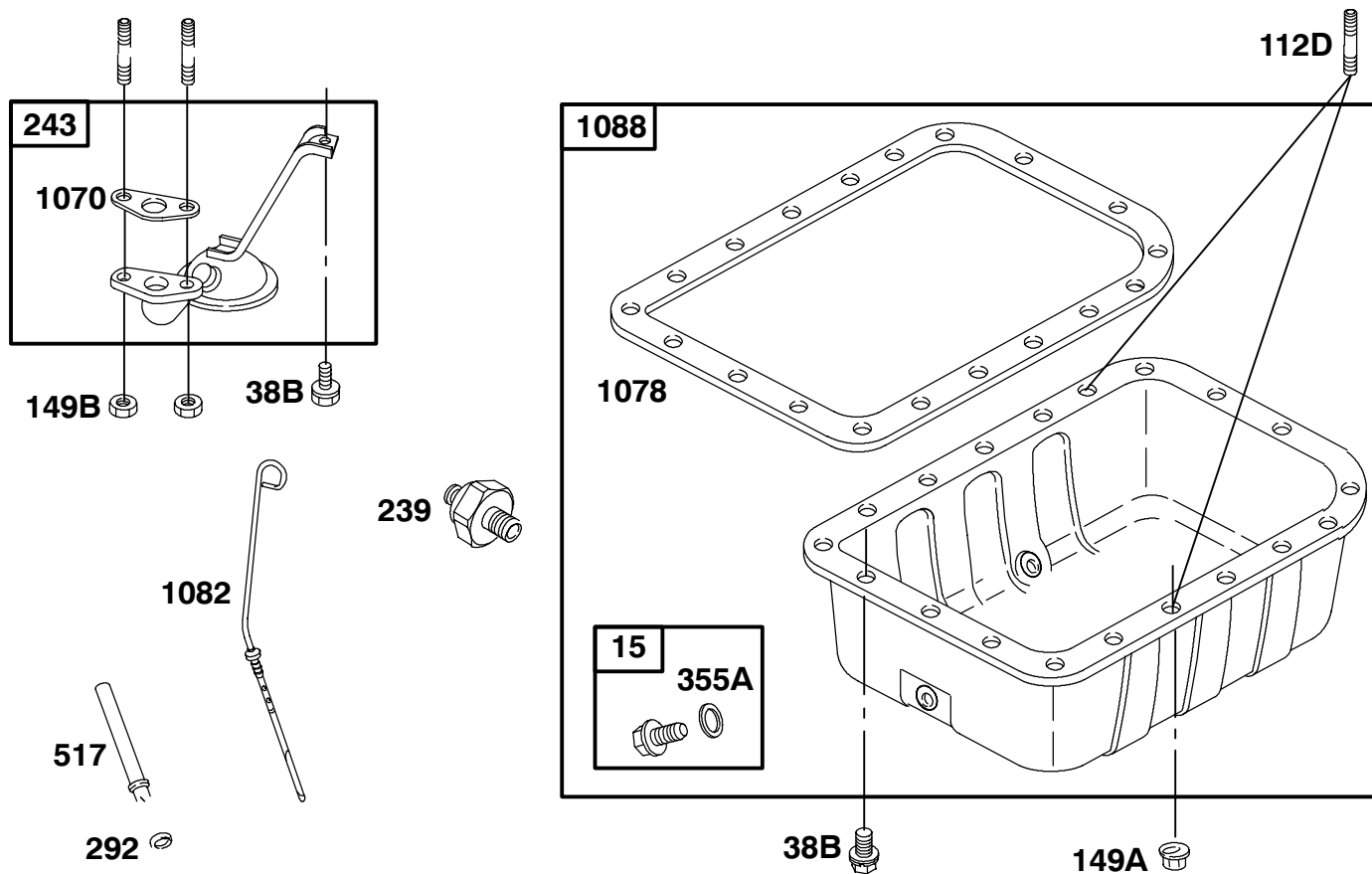

522447-0107-E2 TORO DIESEL

Ref. No.	Part No.	Qty.	Description	Ref. No.	Part No.	Qty.	Description
★1070	99-9120	1	Gasket-Oil Strainer				
★1078	99-9121	1	Gasket-Oil Pan				
1082	100-6405	1	Dipstick				
▽1088	99-9649	1	Pan-Oil				
112D	99-9112	2	Stud-Metric				
149A	99-9113	2	Nut-Metric Hex				
149B	99-9114	2	Nut-Metric Hex				
15	99-9644	1	Plug-Oil Drain				
239	99-9115	1	Switch-Oil Pressure				
▽243	99-9116	1	Screen-Oil Pump				
292	99-9265	1	O-Ring Seal (Dipstick)				
★355A	99-9645	1	Washer-Seal				
38B	99-9111	18	Screw-6mm Hex				
517	100-6406	1	Tube-Dipstick				

▽ Refer To Repair Manual MS 1055 For Assembly and/or Torque Requirements.

★ Included in Gasket Set - Part Number 99-9667

△ Included in Valve Overhaul Kit - Part Number 99-9668

Assemblies include all parts shown in frames.

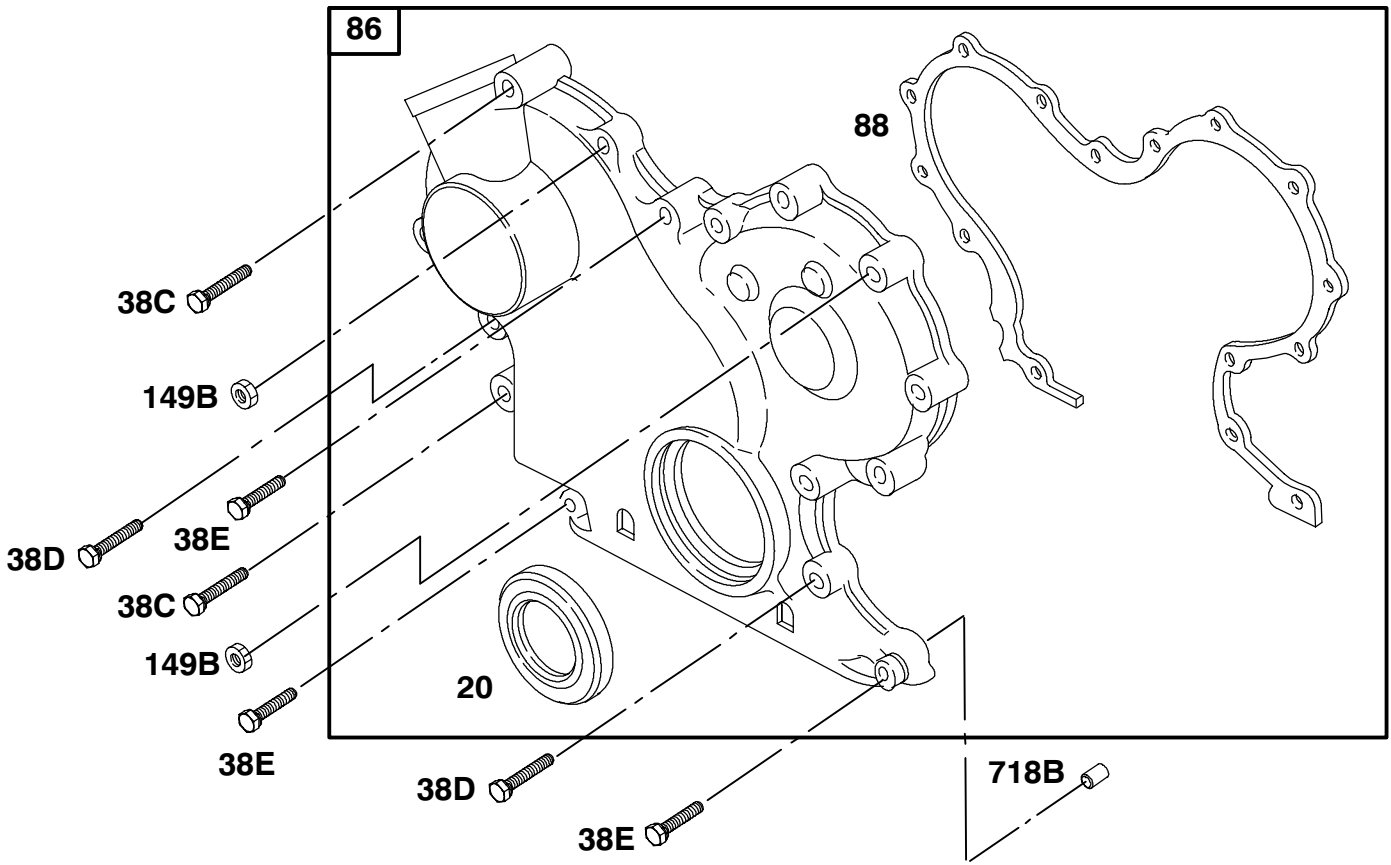

522447-0107-E2 TORO DIESEL

Ref. No.	Part No.	Qty.	Description	Ref. No.	Part No.	Qty.	Description
149B	99-9114	2	Nut-Metric Hex				
★20	99-9126	1	Seal-Oil				
38C	99-9651	2	Screw-6mm Hex				
38D	99-9128	9	Screw-6mm Hex				
38E	99-9129	3	Screw-6mm Hex				
718B	99-9014	1	Pin-Locating				
▽86	99-9652	1	Cover-Assembly-Gear				
★88	99-9653	1	Gasket-Gear Cover				

PROTOTYPE

▽ Refer To Repair Manual MS 1055 For Assembly and/or Torque Requirements.

★ Included in Gasket Set - Part Number 99-9667

△ Included in Valve Overhaul Kit - Part Number 99-9668

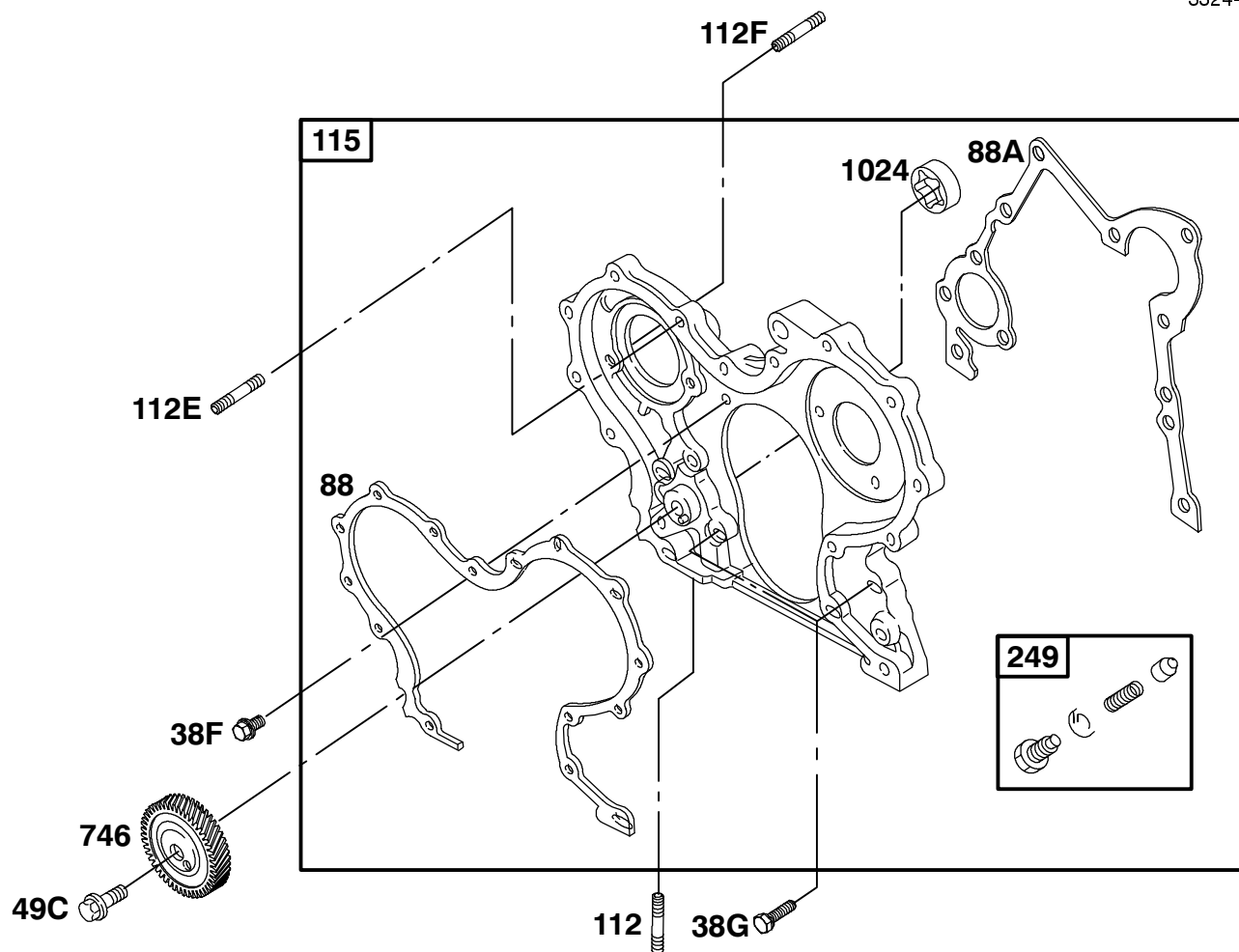

522447-0107-E2 TORO DIESEL

Ref. No.	Part No.	Qty.	Description	Ref. No.	Part No.	Qty.	Description
112	99-9007	1	Stud-Metric				
112E	99-9137	2	Stud-Metric				
112F	99-9654	2	Stud-Metric				
∇115	99-9655	1	Housing-Gear				
∇249	99-9142	1	Valve-Oil Relief				
38F	99-9134	1	Screw-6mm Hex				
38G	99-9133	4	Screw-6mm Hex				
49C	99-9135	1	Screw-8mm Hex				
∇746	99-9656	1	Gear-Drive				
★88	99-9653	1	Gasket-Gear Cover				
★88A	99-9136	1	Gasket-Gear Cover				
1024			Gear-Drive Pump-Oil (Sold in Gear Housing Only, Ref. 115)				

∇ Refer To Repair Manual MS 1055 For Assembly and/or Torque Requirements.

★ Included in Gasket Set - Part Number 99-9667

△ Included in Valve Overhaul Kit - Part Number 99-9668

Assemblies include all parts shown in frames.

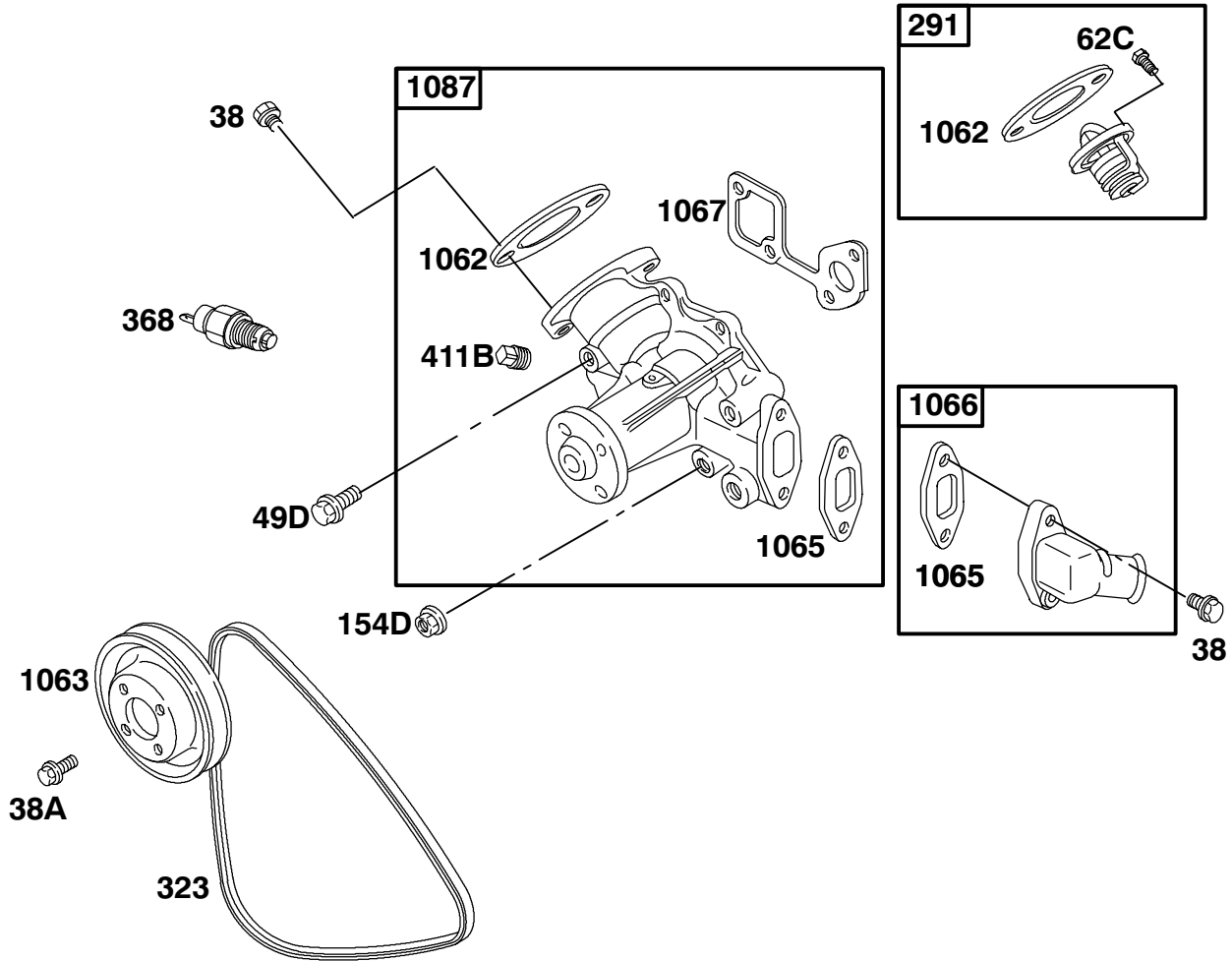

522447-0107-E2 TORO DIESEL

Ref. No.	Part No.	Qty.	Description	Ref. No.	Part No.	Qty.	Description
★1062	99-9163	1	Gasket-Outlet				
1063	99-9164	1	Pulley-Pump				
★1065	99-9166	1	Gasket-Inlet Housing				
1066	99-9167	1	Housing-Inlet				
★△1067	99-9168	1	Gasket-Water Pump				
1087	99-9659	1	Pump-Water				
154D	99-9153	1	Nut-Metric Hex				
291	99-9155	1	Thermostat				
▽323	99-8153	1	Belt-V				
368	99-9157	1	Switch-Water Temp.				
38	99-9004	2	Screw-Hex				
38A	99-9111	4	Screw-6mm Hex				
411B	99-9159	1	Plug				
49D	99-9151	2	Screw-8mm Hex				
62C	99-9152	1	Screw-Metric				
839	93-2090	1	Fan - Engine, 280 Mm				

PROTOTYPE

▽ Refer To Repair Manual MS 1055 For Assembly and/or Torque Requirements.

★ Included in Gasket Set - Part Number 99-9667

△ Included in Valve Overhaul Kit - Part Number 99-9668

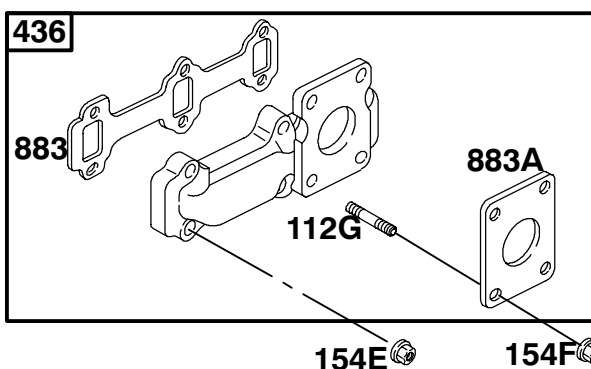
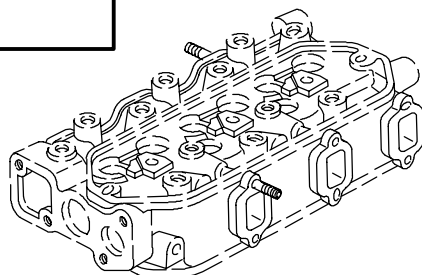
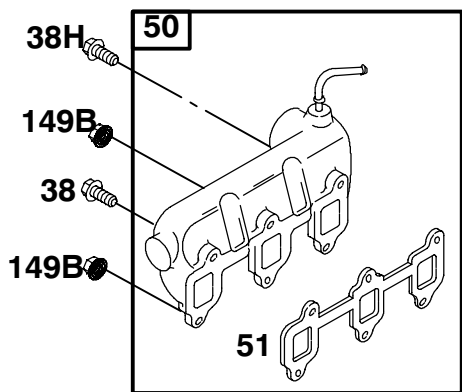

522447-0107-E2 TORO DIESEL

Ref. No.	Part No.	Qty.	Description	Ref. No.	Part No.	Qty.	Description
112G	100-6407	4	Stud-Exhaust Manifold				
149B	99-9114	2	Nut-Metric Hex				
154E	99-9175	6	Nut-Metric Hex				
154F	99-9176	4	Nut-Metric Hex				
38	99-9004	1	Screw-Hex				
38H	99-9660	3	Screw-6mm Hex				
∇436	99-9177	1	Manifold-Exhaust				
∇50	99-9661	1	Manifold-Intake				
★Δ51	99-9662	1	Gasket-Intake				
★Δ883	99-9178	1	Gasket-Exhaust				
★883A	99-9179	1	Gasket-Exhaust				

∇ Refer To Repair Manual MS 1055 For Assembly and/or Torque Requirements.

★ Included in Gasket Set - Part Number 99-9667

Δ Included in Valve Overhaul Kit - Part Number 99-9668

Assemblies include all parts shown in frames.

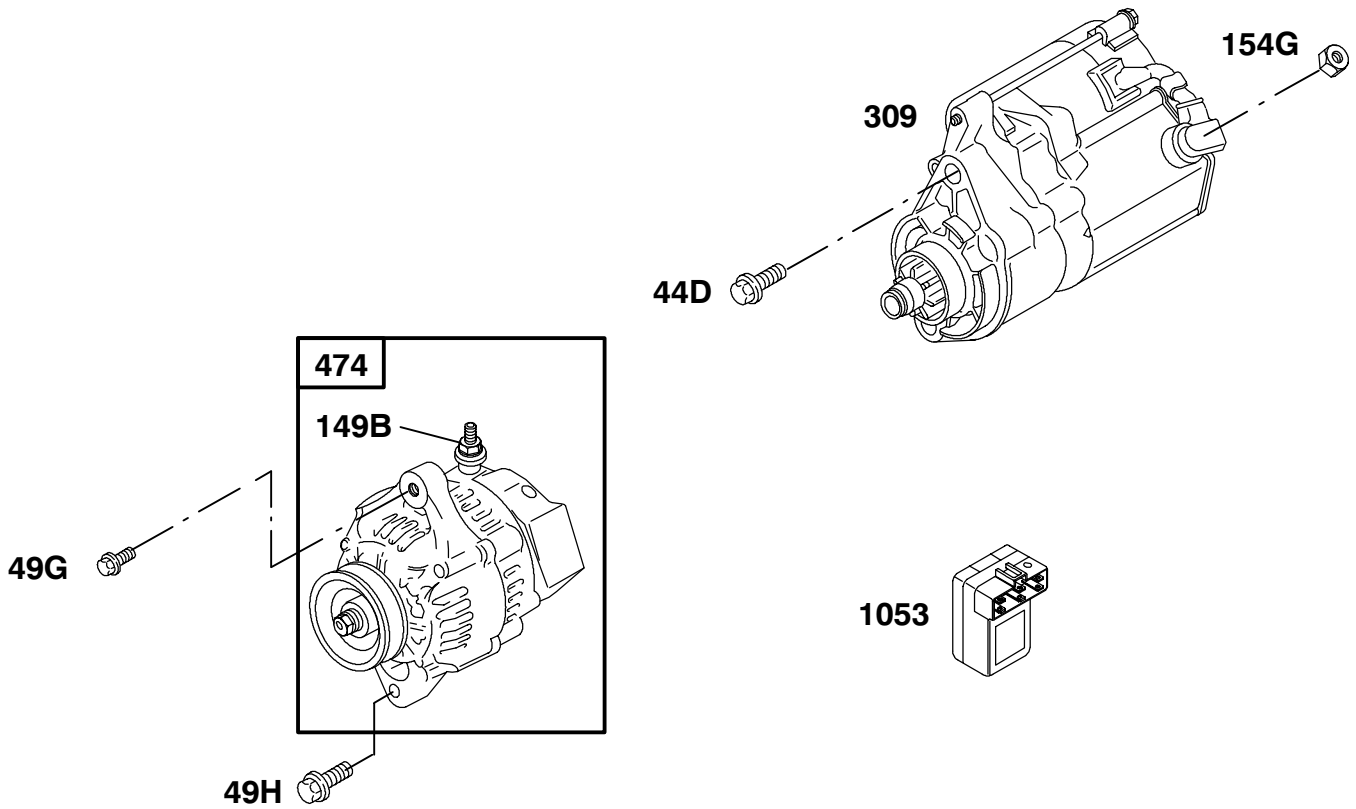

522447-0107-E2 TORO DIESEL

Ref. No.	Part No.	Qty.	Description
1053	99-9666	1	Module
149B	99-9114	1	Nut-Metric Hex
154G	99-9206	1	Nut-Metric Hex
▽309	99-9693	1	Motor-Starter
44D	99-9201	2	Screw-10mm Hex
474	99-9209	1	Alternator

Ref. No.	Part No.	Qty.	Description

PROTOTYPE

▽ Refer To Repair Manual MS 1055 For Assembly and/or Torque Requirements.

★ Included in Gasket Set - Part Number 99-9667

△ Included in Valve Overhaul Kit - Part Number 99-9668

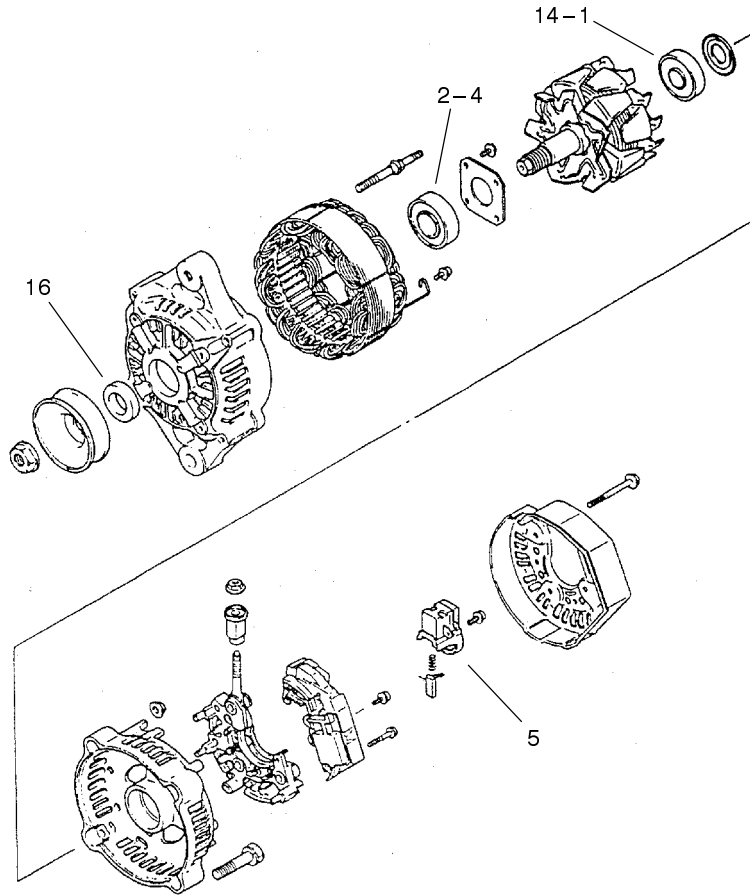

Sheet No.: 0
T-3540

Alternator Assembly No. 99-9209

Ref. No.	Part No.	Qty.	Description
14-1	100-5317	1	Bearing
16	100-5315	1	Collar
2-4	100-5316	1	Bearing
5	100-5318	1	Brush Holder ASM

Ref. No.	Part No.	Qty.	Description
<p style="font-size: 48px; opacity: 0.5; letter-spacing: 10px;">PROTOTYPE</p>			

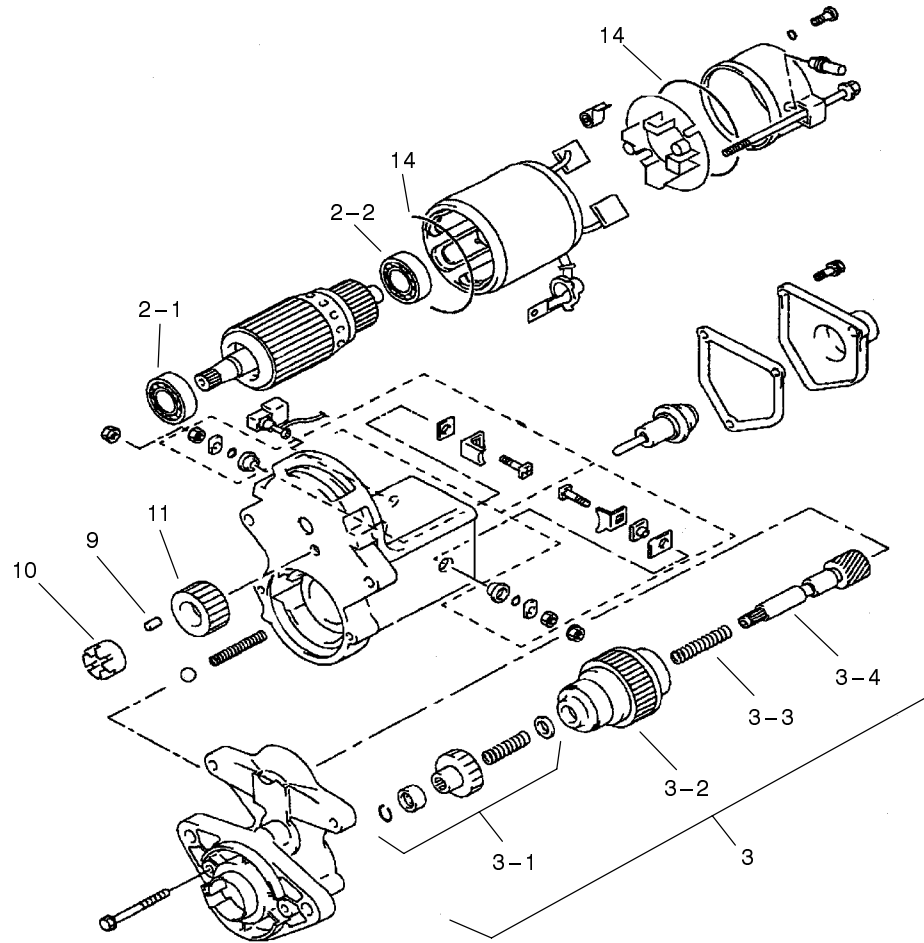

Sheet No.: 0
T-3541

Starter Assembly No. 99-9693

Ref. No.	Part No.	Qty.	Description
10	100-5322	1	Retainer
11	100-5323	1	Pinion, Starter
14	100-5329	2	O-Ring
2-1	100-5319	1	Bearing
2-2	100-5320	1	Bearing
3	100-5324	1	Clutch Sub-ASM, Starter
3-1	100-5325	1	Starter Kit
3-2	100-5326	1	Clutch-Starter
3-3	100-5327	1	Spring
3-4	100-5328	1	Shaft
9	100-5321	5	Roller-clutch

Ref. No.	Part No.	Qty.	Description

PROTOTYPE



PROTOTYPE