



Hydraulic Blade

Dingo[®] Attachment

Model No. 22414—210000001 and Up

Parts Catalog

Ordering Replacement Parts

To order replacement parts, please supply: the part number, the quantity, and the description of each part desired.

Understanding Reference Numbers

Each identified part in an illustration has a reference number. The reference number for a part also appears in the parts list, along with other information about the part.

This catalog uses two special reference number formats, one to indicate parts in a service assembly and another to indicate the quantity of a given part in an illustration.

Service Assembly Reference Numbers

Parts in service assemblies have reference numbers in the form **a:b**. The **a** represents the reference number of the entire service assembly and the **b** represents a sequential number unique to each part within the service assembly.

For example, a wheel assembly might be identified by reference number **6**, the tire by **6:1**, the valve by **6:2**, and the wheel by **6:3**. When you order the assembly identified by reference number **6**, you receive all parts identified by reference numbers **6:1**, **6:2**, and **6:3**. However, you may also order any part individually.

Reference numbers of this type appear in illustrations and in part lists.

Reference Numbers Indicating Quantity

In an illustration, if a reference number indicates more than one part, the reference number has the form **nX y**. The **n** represents the quantity of the part, the **X** is the multiplication symbol, and the **y** represents the reference number.

For example, in an illustration, the reference number **2X 37** means that two of the parts identified by reference number **37** are indicated.

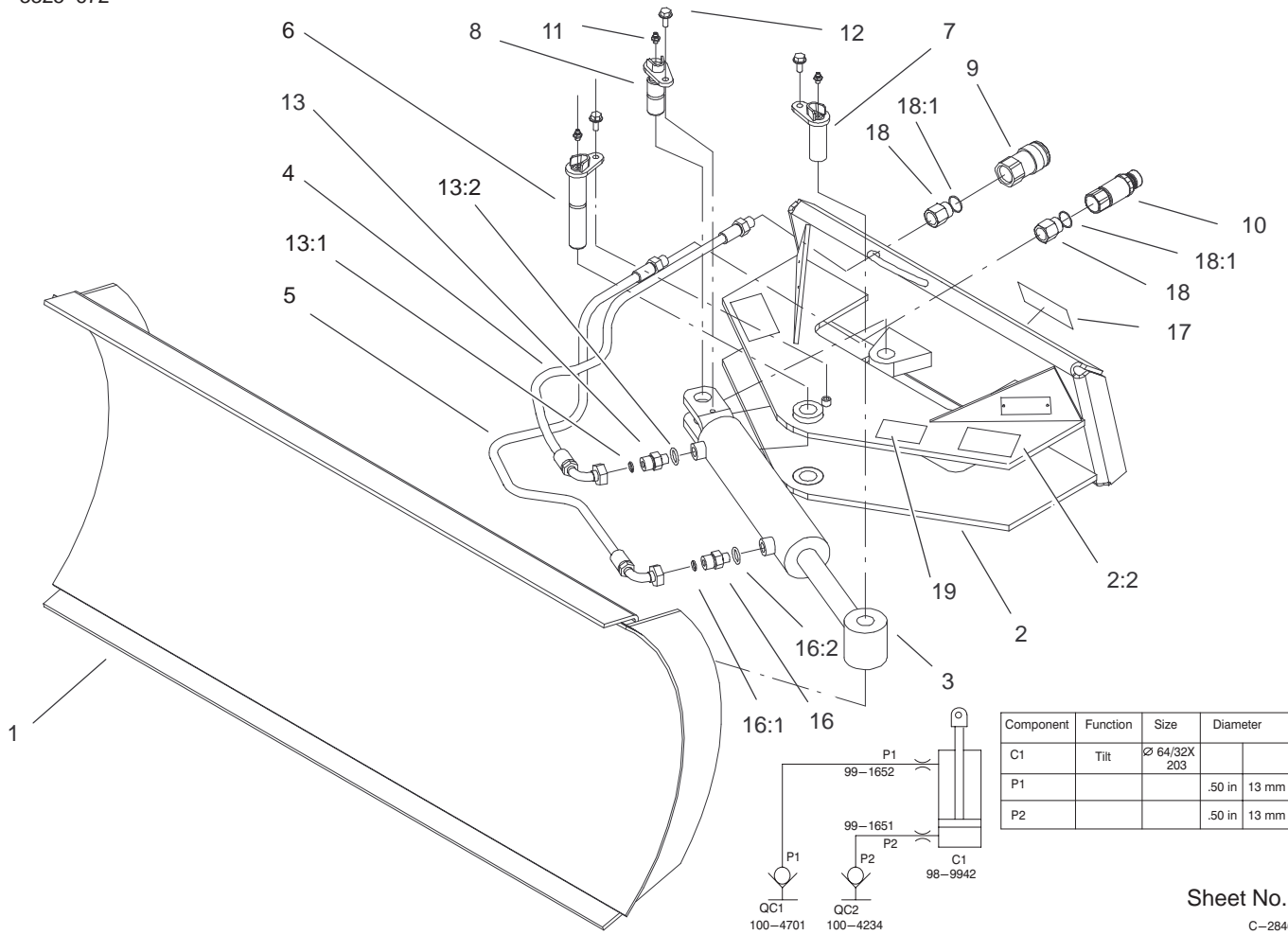

Component	Function	Size	Diameter
C1	Tilt	∅ 64/32X 203	
P1			.50 in 13 mm
P2			.50 in 13 mm

Sheet No.:1
C-2846

Hydraulic Blade Assembly

Ref. No.	Part No.	Qty.	Description
1	98-8240-03	1	Blade ASM
2	99-4306	1	Blade Pivot ASM
2:2	100-4650	1	Decal-Warning
3	98-9942	1	Cylinder - Hydraulic
4	99-1651	1	Hose - Hydraulic
5	99-1652	1	Hose - Hydraulic
6	94-1598	1	Pin-Pivot
7	94-9797	1	Pin-Pivot
8	98-4870	1	Pin-Pivot
9	100-4234	1	Coupler-Face, Flush
*9:1	100-6119	1	Kit-Seal
10	100-4701	1	Nipple-Connect, Pressure
*10:1	100-6120	1	Kit-Seal
11	302-5	3	Fitting-Grease
12	32144-70	3	Screw-HH
13	340-5	1	Fitting-Straight
13:1	237-42	1	O-Ring
13:2	237-30	1	O-Ring
16	99-1650	1	Straight - Connector
16:1	237-42	1	O-Ring
16:2	237-30	1	O-Ring
17	98-4683	1	Decal-Attachment, Dingo
18	100-4617	2	Adapter-Hydraulic

Ref. No.	Part No.	Qty.	Description
18:1	237-80	1	O-Ring
19	98-3269	1	Decal-Made In USA

* Not illustrated

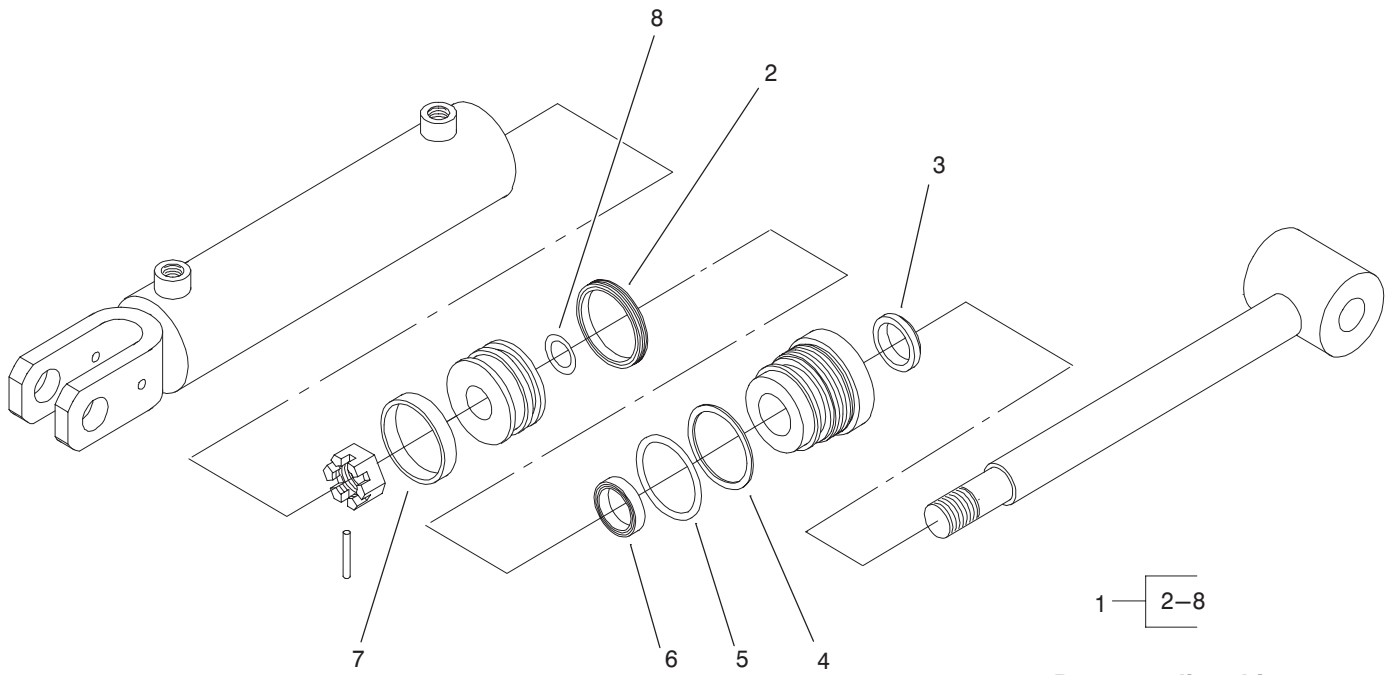

**Parts not listed in
part list are not
serviced separately**

Sheet No.:A1
c-2767

Hydraulic Cylinder Assembly No. 98-9942

Ref. No.	Part No.	Qty.	Description
1	99-1352	1	Seal Kit - Cylinder

Ref. No.	Part No.	Qty.	Description

