



## Topdresser 2500

Model No. 44507—210000001 and Up

### Parts Catalog

---

#### Ordering Replacement Parts

To order replacement parts, please supply: the part number, the quantity, and the description of each part desired.

#### Understanding Reference Numbers

Each identified part in an illustration has a reference number. The reference number for a part also appears in the parts list, along with other information about the part.

This catalog uses two special reference number formats, one to indicate parts in a service assembly and another to indicate the quantity of a given part in an illustration.

#### Service Assembly Reference Numbers

Parts in service assemblies have reference numbers in the form **a:b**. The **a** represents the reference number of the entire service assembly and the **b** represents a sequential number unique to each part within the service assembly.

For example, a wheel assembly might be identified by reference number **6**, the tire by **6:1**, the valve by **6:2**, and the wheel by **6:3**. When you order the assembly identified by reference number **6**, you receive all parts identified by reference numbers **6:1**, **6:2**, and **6:3**. However, you may also order any part individually.

Reference numbers of this type appear in illustrations and in part lists.

#### Reference Numbers Indicating Quantity

In an illustration, if a reference number indicates more than one part, the reference number has the form **nX y**. The **n** represents the quantity of the part, the **X** is the multiplication symbol, and the **y** represents the reference number.

For example, in an illustration, the reference number **2X 37** means that two of the parts identified by reference number **37** are indicated.

## Contents

<b>Description</b>	<b>Page</b>	<b>Description</b>	<b>Page</b>
Cradle Assembly .....	3	Brush and Motors Assembly .....	10
Cradle and Trailer Assembly .....	4	Hopper Assembly .....	11
Hydraulic Manifold Assembly .....	6	Gate Slide and Brush Guard Assembly .....	12
Hydraulics Installation Assembly .....	7	Chain, Sprocket and Guard Assembly .....	13
Slider Bed and Roller Assembly .....	8	Hydraulic Schematic .....	14
Gate Assembly .....	9	Electrical Schematic .....	15

## Accessories

<b>Description</b>	<b>Model / Part No.</b>	<b>Description</b>	<b>Model / Part No.</b>
Hydraulic Brake Kit .....	99-0154	Hydraulic Filter .....	86-3010
Mobil EAL 224H (5 gallon) (or contact distributor)	100-7674	Tongue Jack .....	98-5016 (required for CE compliance)

## Part Description Abbreviations

Part descriptions in this catalog may include the following abbreviations.

<b>Abbreviation</b>	<b>Meaning</b>	<b>Abbreviation</b>	<b>Meaning</b>
AR .....	as required	HYD .....	hydraulic
ASM .....	assembly	INC .....	incorporated
CARR .....	carriage	LH .....	left hand
DEG .....	degrees	NI .....	nylon insert
FH .....	flat head	PPH .....	Phillips pan head
GA .....	gauge	PTH .....	Phillips truss head
HF .....	hex flange	PTO .....	power take off
HH .....	hex head	RH .....	right hand
HHF .....	hex head flange	SFH .....	slotted fillister head
HLH .....	hex lag head	SHH .....	slotted hex head
HJ .....	hex jam	SQH .....	square head
HOC .....	height-of-cut	SHWH .....	slotted hex washer head
HS .....	hex socket	SPH .....	slotted pan head
HSBH .....	hex socket button head	SRH .....	slotted round head
HSFH .....	hex socket flat head	STD .....	standard
HSH .....	hex socket head	TAP .....	self tapping
HWH .....	hex washer head	TTH .....	Torx truss head
HWHTF .....	hex washer head thread forming	WH .....	wing head

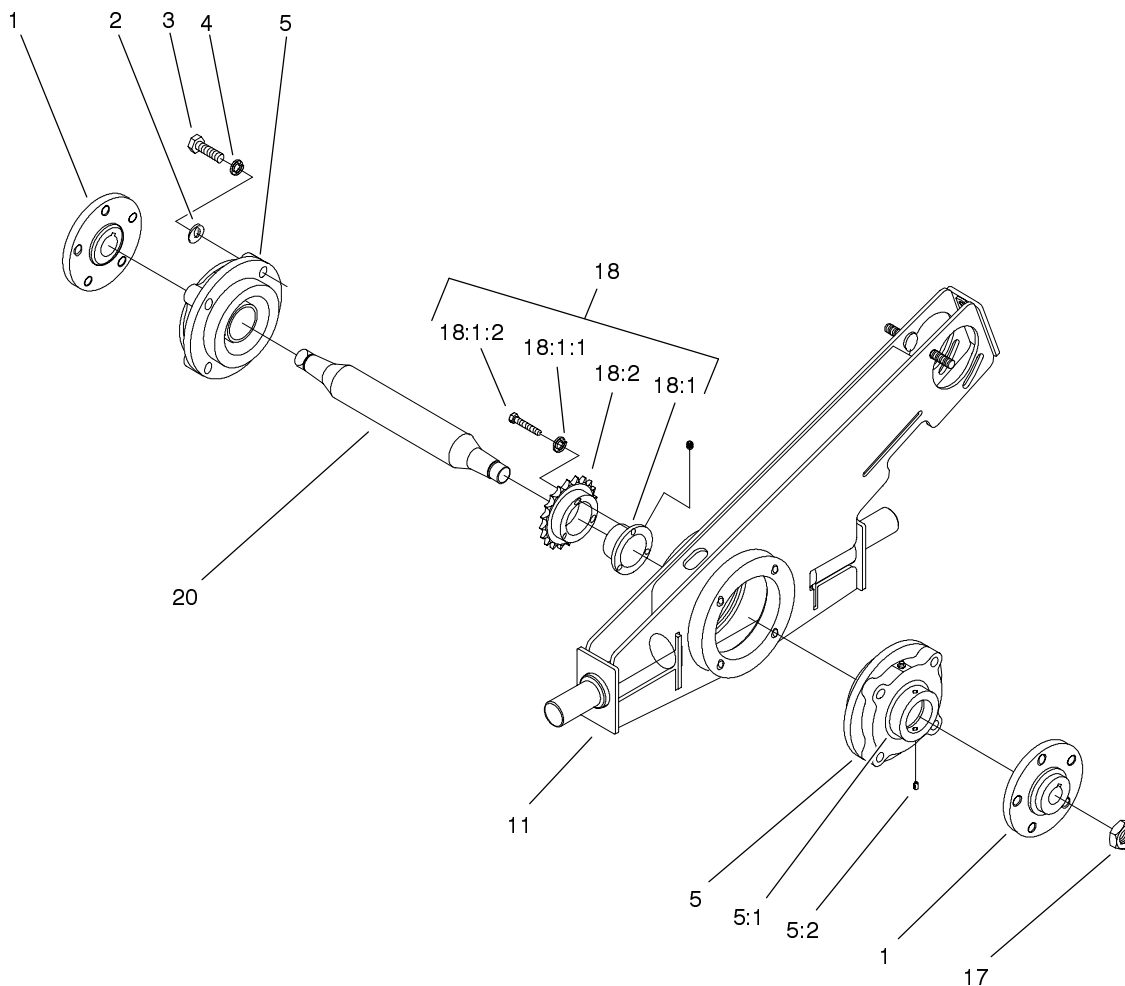

Sheet No.:2

### Cradle Assembly

Ref. No.	Part No.	Qty.	Description
1	100-1418-03	4	Hub
2	3256-26	16	Washer-Flat
3	325-7	16	Screw-HH
4	3253-7	16	Washer-Lock
5	100-1455	4	Bearing
5:1	99-0194	1	Collar-Locking
5:2	99-0195	1	Screw-Set, HS
11	100-1488-03	2	Cradle ASM
17	26-3790	4	Nut-Lock
18	100-7690	2	Sprocket And Hub ASM
18:1	100-7730	1	Bushing
18:1:1	3253-18	3	Washer-Lock/Sp
18:1:2	32104-96	3	Screw-HH
18:2	100-7731	1	Sprocket-Driven, 20 Tooth
20	100-1490	2	Axle-Cradle

Ref. No.	Part No.	Qty.	Description
----------	----------	------	-------------

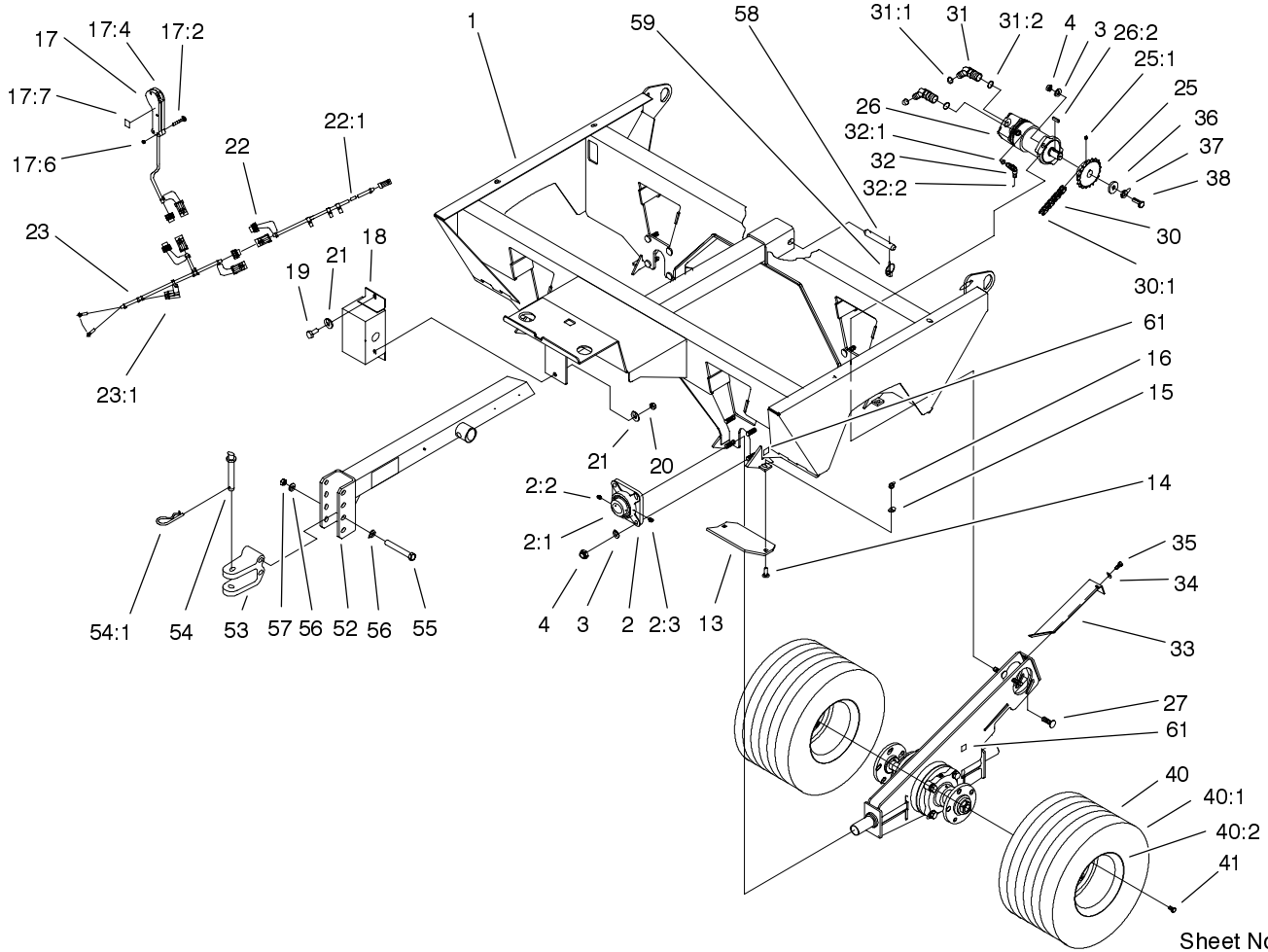

Sheet No.:3

## Cradle and Trailer Assembly

Ref. No.	Part No.	Qty.	Description
1	100-1480-01	1	Frame-Trailer
2	100-1456	4	Bearing
2:1	01-172-0090	1	Collar-Lock
2:2	3246-16	1	Screw-Set
2:3	302-2	1	Zerk
3	3256-26	20	Washer-Flat
4	3296-23	20	Nut-Lock, NI
13	100-7678-01	4	Plate-Skid
14	3231-25	8	Screw-CARR
15	3256-25	8	Washer-Flat
16	3296-39	8	Nut-Lock, NI
17	100-7680	1	Control Handle ASM
17:2	100-7681	4	Screw-Srh
17:4	01-603-0760	1	Boot-Rubber
*17:5	01-603-0750	1	Switch-Pole, Single
17:6	3217-32	4	Nut-Hex
17:7	100-7682	2	Decal-On/Off
18	100-1410-03	1	Pump-Charge
19	325-5	2	Screw-HH
20	3296-45	2	Nut-Lock, NI
21	3256-6	4	Washer-Flat
22	99-0008	1	Harness-Wire, Trailer
22:1	100-4918	1	Diode
23	99-0198	1	Harness-Wire, Battery
23:1	110928	1	Fuse-5 Amp

Ref. No.	Part No.	Qty.	Description
25	100-7691	2	Sprocket-Chain, Roller
25:1	3246-3	2	Screw-HS
26	100-1459	2	Motor-HYD
*26:1	100-1466	1	Kit-Seal
26:2	5-7280	1	Key
27	100-7698	2	Bolt-Carriage
30	100-1472	2	Chain-Cradle, Roller
30:1	2710-16	1	Link-Chain
31	340-14	4	Fitting-HYD, 45 DEG
31:1	237-65	1	O-Ring
31:2	237-80	1	O-Ring
32	340-103	2	Fitting
32:1	237-78	1	O-Ring
32:2	237-21	1	O-Ring
33	100-1452	2	Cover-Cradle, Top
34	3256-24	2	Washer-Flat
35	323-4	2	Screw-HH
36	71-5320	2	Washer-Support, Engine
37	3253-4	2	Washer-Lock
38	322-3	2	Screw-HH
40	99-0169	4	Wheel & Tire ASM
40:1	99-0173	1	Tire
40:2	99-0174	1	Rim
*40:3	232-27	1	Stem-Valve

\* Not illustrated

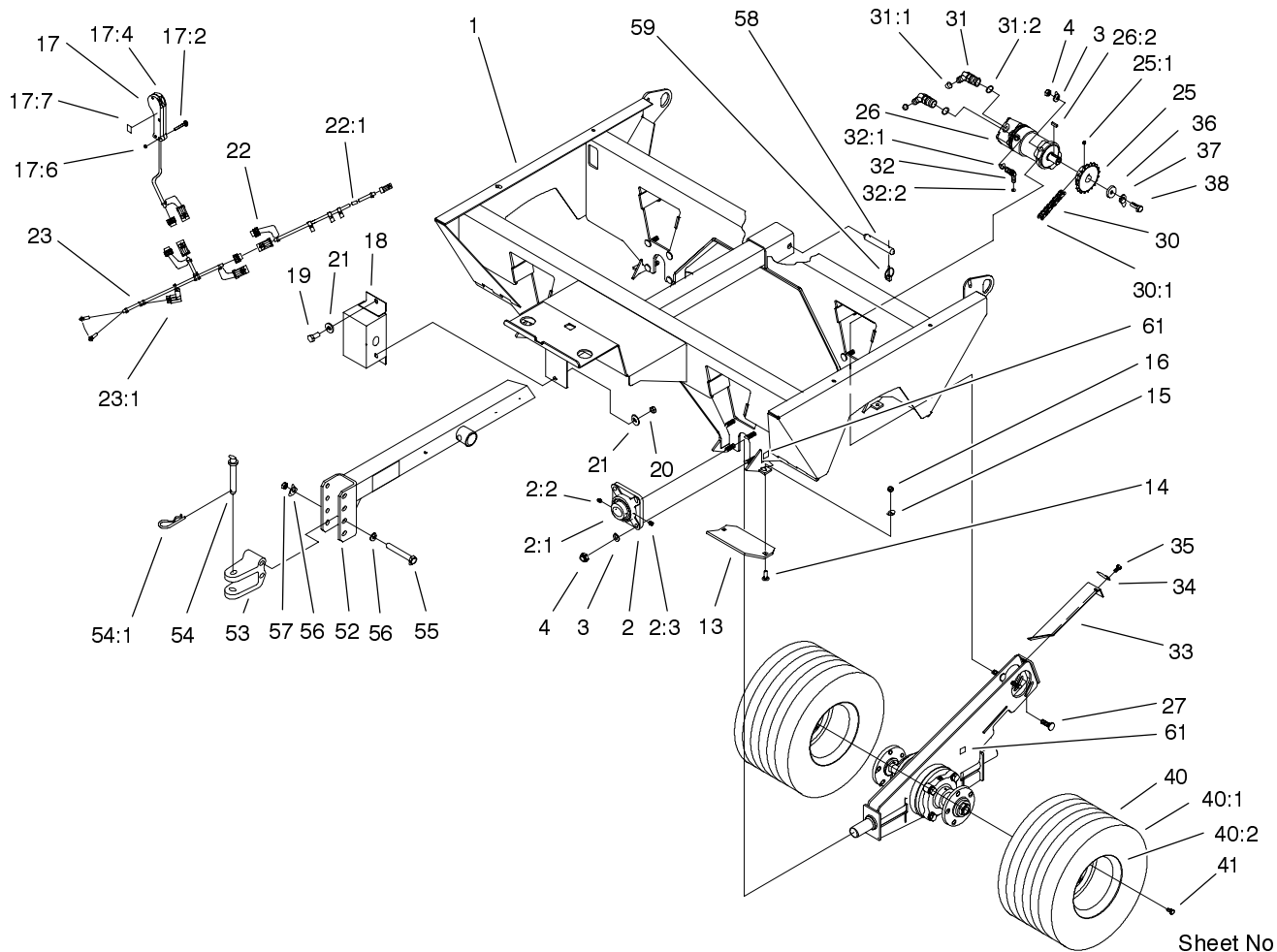

Sheet No.:3

# Cradle and Trailer Assembly (Continued)

Ref. No.	Part No.	Qty.	Description
41	71-4450	20	Bolt-Lug
52	100-7686	1	Tongue ASM
53	47-3550-01	1	Hitch Clevis
54	13-6200	1	Hitch-Pointed, Pin
54:1	3290-343	1	Pin-Hair
55	327-23	2	Screw-HH
56	3256-7	4	Washer-Flat
57	3296-53	2	Nut-Lock NI
58	100-7694	2	Pin-Clevis
59	92-1298	4	Pin - Lynch
61	58-6520	8	Decal-Grease

Ref. No.	Part No.	Qty.	Description

\* Not illustrated

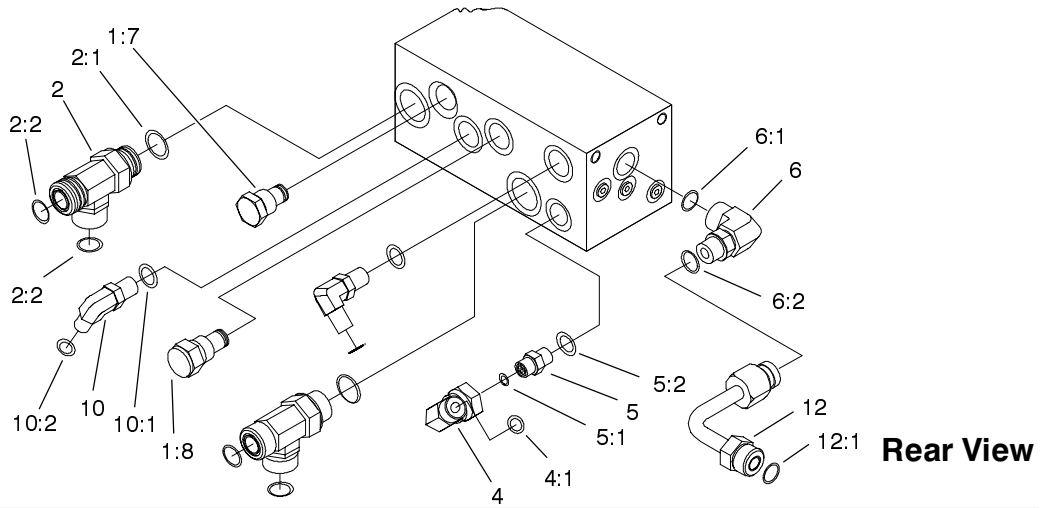

**Rear View**

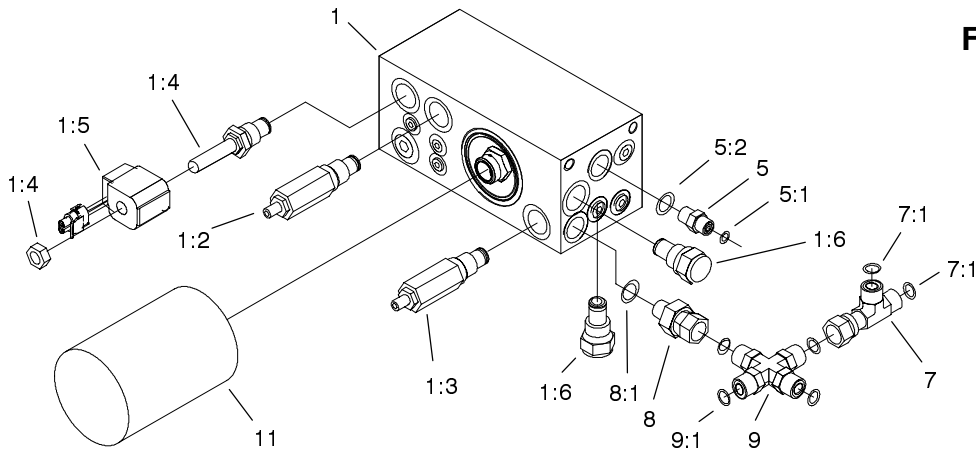

**Front View**

Sheet No.:4

## Hydraulic Manifold Assembly

Ref. No.	Part No.	Qty.	Description
1	100-7728	1	Manifold-HYD
1:2	100-7740	1	Valve-Relief
1:3	100-7717	1	Valve-Relief
1:4	100-7718	1	Valve-Solenoid
1:5	100-7720	1	Coil-Solenoid
1:6	100-7721	2	Valve-Check
1:7	100-7723	1	Valve-Check
1:8	100-7722	1	Valve-Check
2	340-148	2	Fitting
2:1	237-81	1	O-Ring
2:2	237-58	2	O-Ring
4	94-6031	1	Fitting-HYD
4:1	237-30	1	O-Ring
5	340-4	2	Adapter
5:1	237-30	1	O-Ring
5:2	237-79	1	O-Ring
6	340-98	1	Fitting-90 DEG
6:1	237-79	1	O-Ring
6:2	237-30	1	O-Ring
7	340-104	1	T-Fitting
7:1	237-151	2	O-Ring
8	100-7671	1	Adapter-HYD
8:1	237-79	1	O-Ring
9	100-7670	1	Adapter-HYD
9:1	237-151	4	O-Ring
10	340-17	2	Adapter

Ref. No.	Part No.	Qty.	Description
10:1	237-65	1	O-Ring
10:2	237-80	1	O-Ring
11	86-3010	1	Filter-Oil, Transmission
12	100-7713	1	Hydraulic Tube ASM
12:1	237-151	1	O-Ring

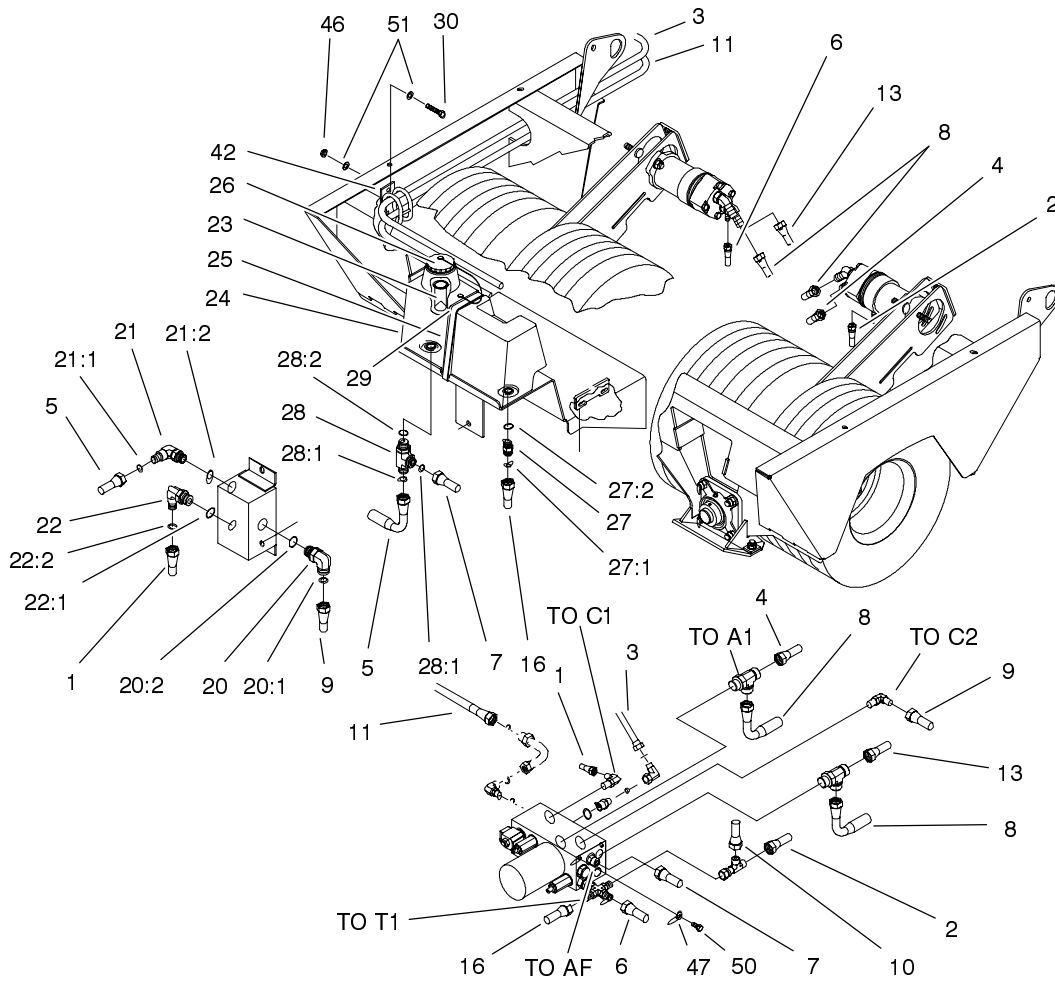

Sheet No.:5

## Hydraulics Installation Assembly

Ref. No.	Part No.	Qty.	Description
1	100-7655	1	HYD Hose ASM
2	100-7664	1	HYD Hose ASM
3	104-0304	1	HYD Hose ASM
4	100-7662	1	HYD Hose ASM
5	100-7657	1	HYD Hose ASM
6	100-7663	1	HYD Hose ASM
7	100-7658	1	HYD Hose ASM
8	100-7661	2	HYD Hose ASM
9	100-7656	1	HYD Hose ASM
10	100-7669	1	Hose ASM
11	104-0303	1	HYD Hose ASM
13	100-7672	1	HYD Hose ASM
16	100-7668	1	Hose ASM
20	340-142	1	Elbow-90 DEG
20:1	237-58	1	O-Ring
20:2	237-81	1	O-Ring
21	340-17	1	Adapter
21:1	237-65	1	O-Ring
21:2	237-80	1	O-Ring
22	340-139	1	Fitting-HYD
22:1	237-81	1	O-Ring
22:2	237-65	1	O-Ring
23	92-1705	1	Filter-Screen
24	94-4700	1	Tank-HYD
25	100-7693	1	Clamp-Tank
26	93-4365	1	Cap-Oil

Ref. No.	Part No.	Qty.	Description
27	340-4	1	Adapter
27:1	237-30	1	O-Ring
27:2	237-79	1	O-Ring
28	340-22	1	Adapter
28:1	237-65	2	O-Ring
28:2	237-80	1	O-Ring
29	3290-126	1	Screw
30	322-5	2	Screw-HH
42	99-5621	1	Guide-Hose
46	3296-29	2	Nut-Lock
47	3256-24	4	Washer-Flat
50	323-5	4	Screw-HH
51	3256-23	4	Washer-Flat
*99	100-7674	1	Oil-HYD, 5 Gallon
*99:1	99-0010	1	Decal-Fluid, HYD

\* Not illustrated

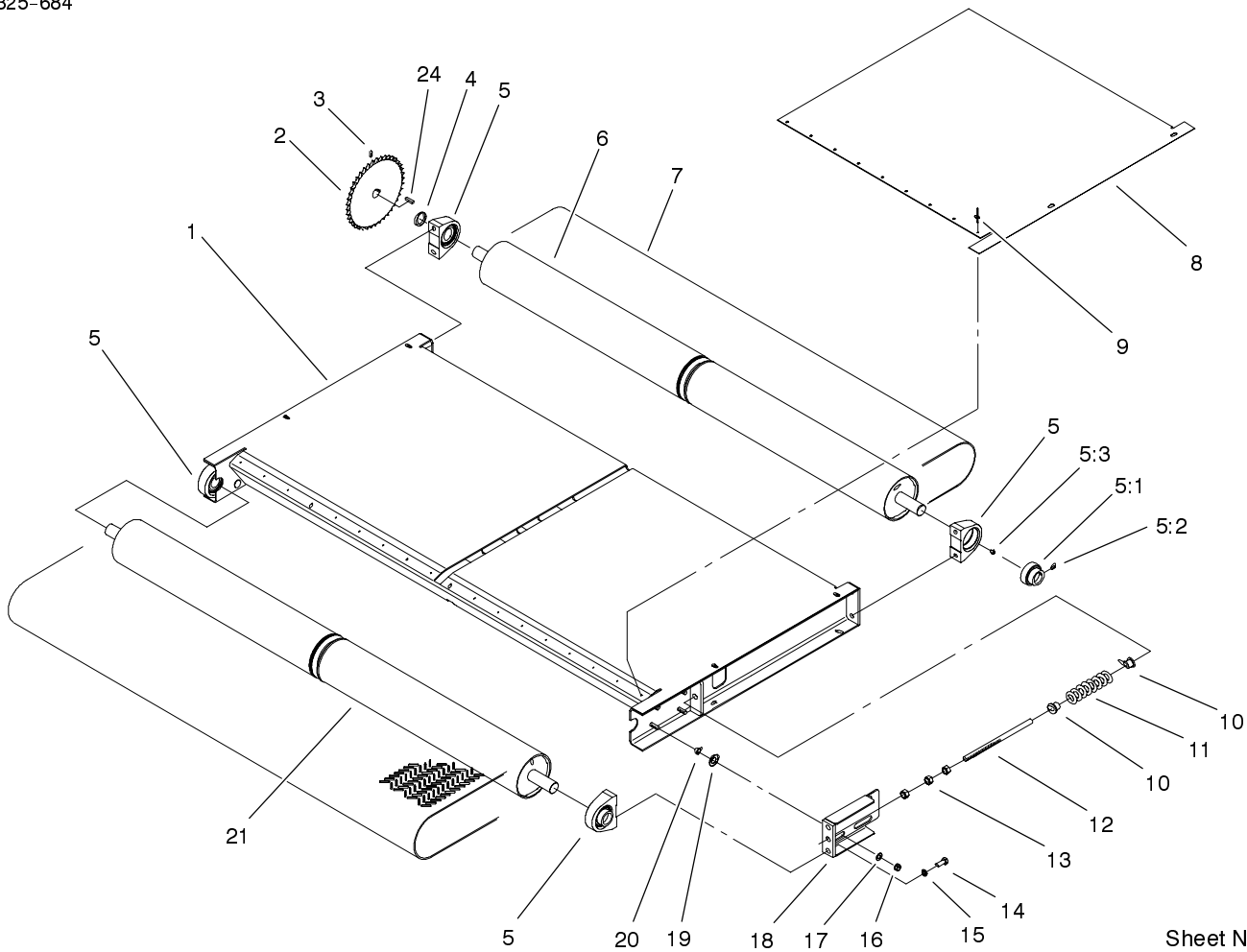

Sheet No.:6

## Slider Bed and Roller Assembly

Ref. No.	Part No.	Qty.	Description
1	99-0038-01	1	Frame-Bed, Slider
2	99-0166-03	1	Sprocket-Driven
3	3246-3	2	Screw-HS
4	99-0017-01	1	Spacer-Sprocket
5	99-0158	4	Bearing-Base, Tapped
5:1	251-246	1	Collar W/Set Screws
5:2	3245-35	1	Screw-HS
5:3	302-33	1	Fitting-Grease
6	99-0046	1	Roller-Rear
7	100-1425	1	Kit-Belt
8	99-0047	2	Plate-Wear
9	3269-28	18	Rivet-Pop
10	100-1414	4	Holder-Spring
11	99-0163	2	Spring-Compression
12	99-0118	2	Pin-Spring
13	3217-9	6	Nut-HH
14	100-1438	8	Screw-Socket Head, Torx
15	3253-6	8	Washer-Lock/Sp
16	3296-39	8	Nut-Lock, NI
17	3256-4	8	Washer-Flat
18	99-0050-01	2	Spring Plate ASM
19	99-0052	8	Washer-Slide
20	100-1401	8	Spacer-Slide, Spring
21	99-0044	1	Roller-Front
24	10-7070	1	Key-Square

Ref. No.	Part No.	Qty.	Description



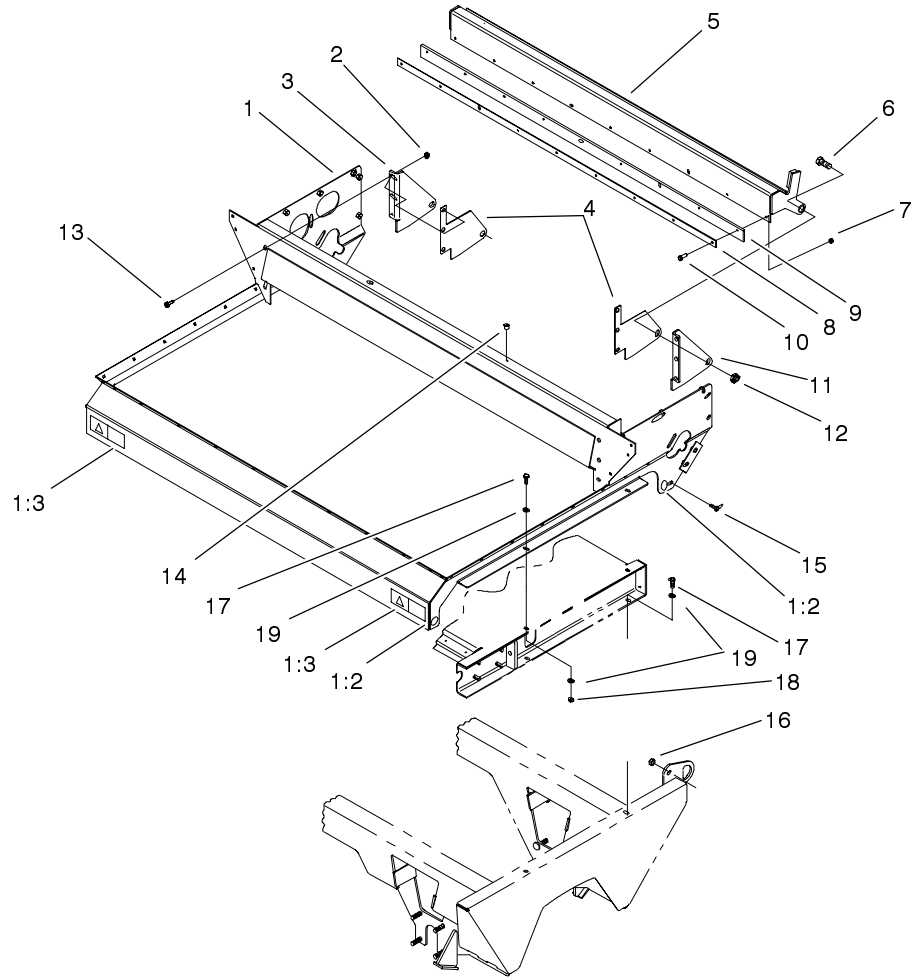

Sheet No.:7

## Gate Assembly

Ref. No.	Part No.	Qty.	Description	Ref. No.	Part No.	Qty.	Description
1	100-1435	1	Hopper Frame ASM				
1:2	58-6520	4	Decal-Grease				
1:3	93-9092	2	Decal-Warning				
2	32128-37	6	Nut-HF				
3	99-0079-01	1	Bracket-Gate Pivot, RH				
4	99-0117	2	Wareplate-Gate				
5	99-0068-01	1	Gate ASM				
6	328-24	2	Screw-HH				
7	3296-29	9	Nut-Lock				
8	99-0089-01	1	Plate-Backing				
9	99-0074	1	Seal-Gate				
10	322-6	9	Screw-HH				
11	99-0078-01	1	Bracket-Gate Pivot, LH				
12	3296-51	2	Nut-Lock, NI				
13	324-4	6	Screw-HH				
14	32148-9	2	Nut-Insert				
15	325-5	2	Screw-HH				
16	3296-23	2	Nut-Lock, NI				
17	323-7	8	Screw-HH				
18	3296-39	4	Nut-Lock, NI				
19	3256-24	12	Washer-Flat				

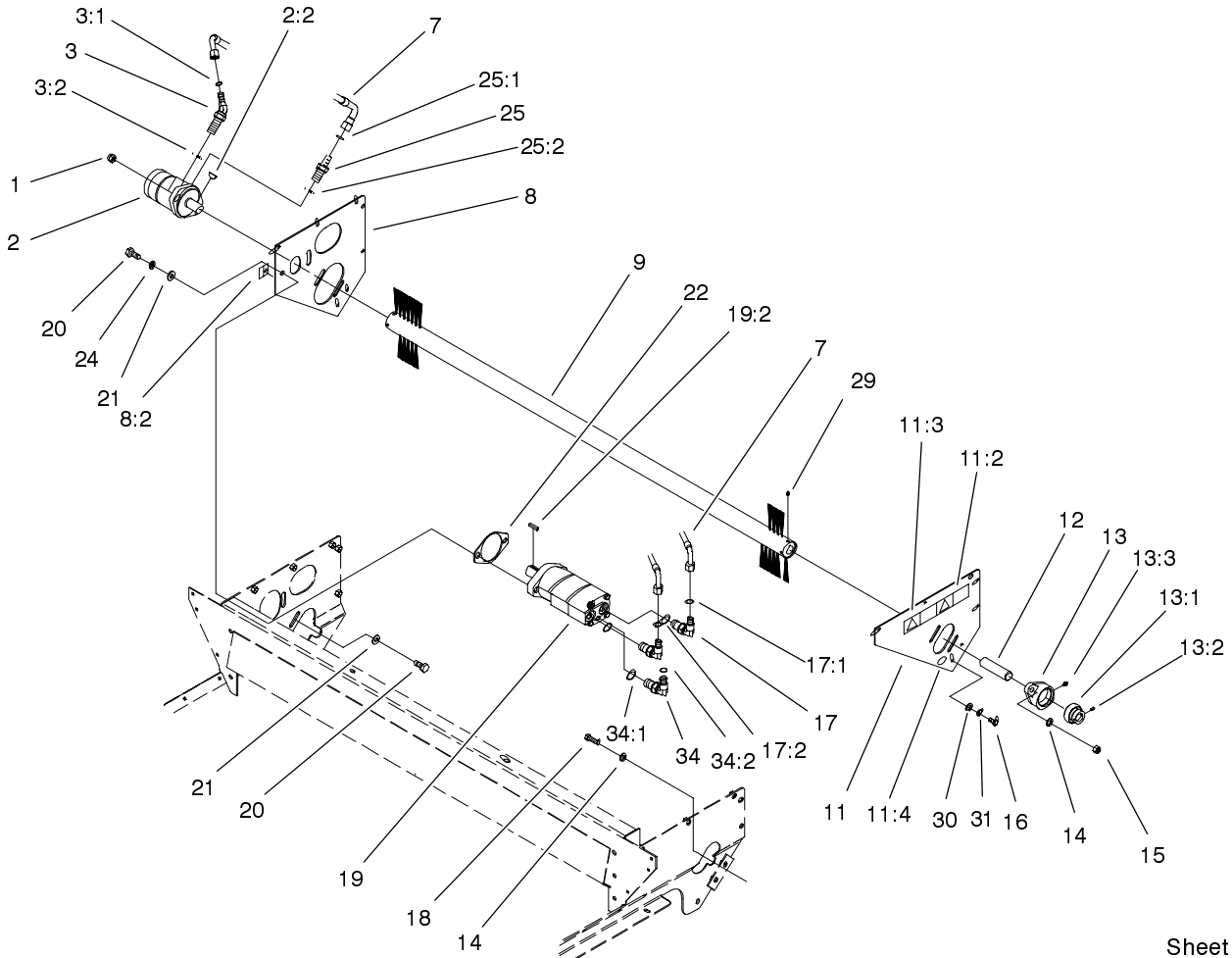

Sheet No.:8

## Brush and Motors Assembly

Ref. No.	Part No.	Qty.	Description
1	3296-45	2	Nut-Lock, NI
2	99-0156	1	Motor-HYD
*2:1	100-1446	1	Kit-Seal
2:2	3257-43	1	Key-Woodruff
3	340-89	1	Fitting-45 DEG
3:1	237-30	1	O-Ring
3:2	237-80	1	O-Ring
7	99-0177	1	Hose-HYD
8	100-1431	1	RH Motor Brace ASM
8:2	98-3114	1	Decal-Warning, Ce
9	99-0162	1	Brush
11	100-1430	1	LH Motor Brace ASM
11:2	99-0015	1	Decal-Danger
11:3	93-9867	1	Decal-No Riders
11:4	58-6520	1	Decal-Grease
12	99-0041	1	Shaft-Brush
13	99-0160	1	Bearing
13:1	251-249	1	Collar W/ Set Screws
13:2	3245-35	1	Screw-HS
13:3	302-2	1	Fitting-Grease
14	3256-25	4	Washer-Flat
15	3296-48	2	Nut-Lock NI
16	323-4	4	Screw-HH
17	340-105	2	Fitting-90 DEG
17:1	237-30	1	O-Ring
17:2	237-80	1	O-Ring

Ref. No.	Part No.	Qty.	Description
18	324-6	2	Screw-HH
19	99-0155	1	Hydraulic Motor Conveyor ASM
*19:1	100-1447	1	Kit-Seal
19:2	10-7070	1	Key-Square
20	325-6	4	Screw-HH
21	3256-26	4	Washer-Flat
22	99-0116	1	Plate-Spacer
24	3253-7	2	Washer-Lock
25	340-6	1	Fitting-HYD, Straight
25:1	237-30	1	O-Ring
25:2	237-80	1	O-Ring
29	3246-3	4	Screw-HS
30	3256-24	4	Washer-Flat
31	3253-21	4	Washer-Lock
34	100-7695	1	Adapter-HYD
34:1	237-78	1	O-Ring
34:2	237-21	1	O-Ring
*99	3290-379	4	Tie-Cable

\* Not illustrated

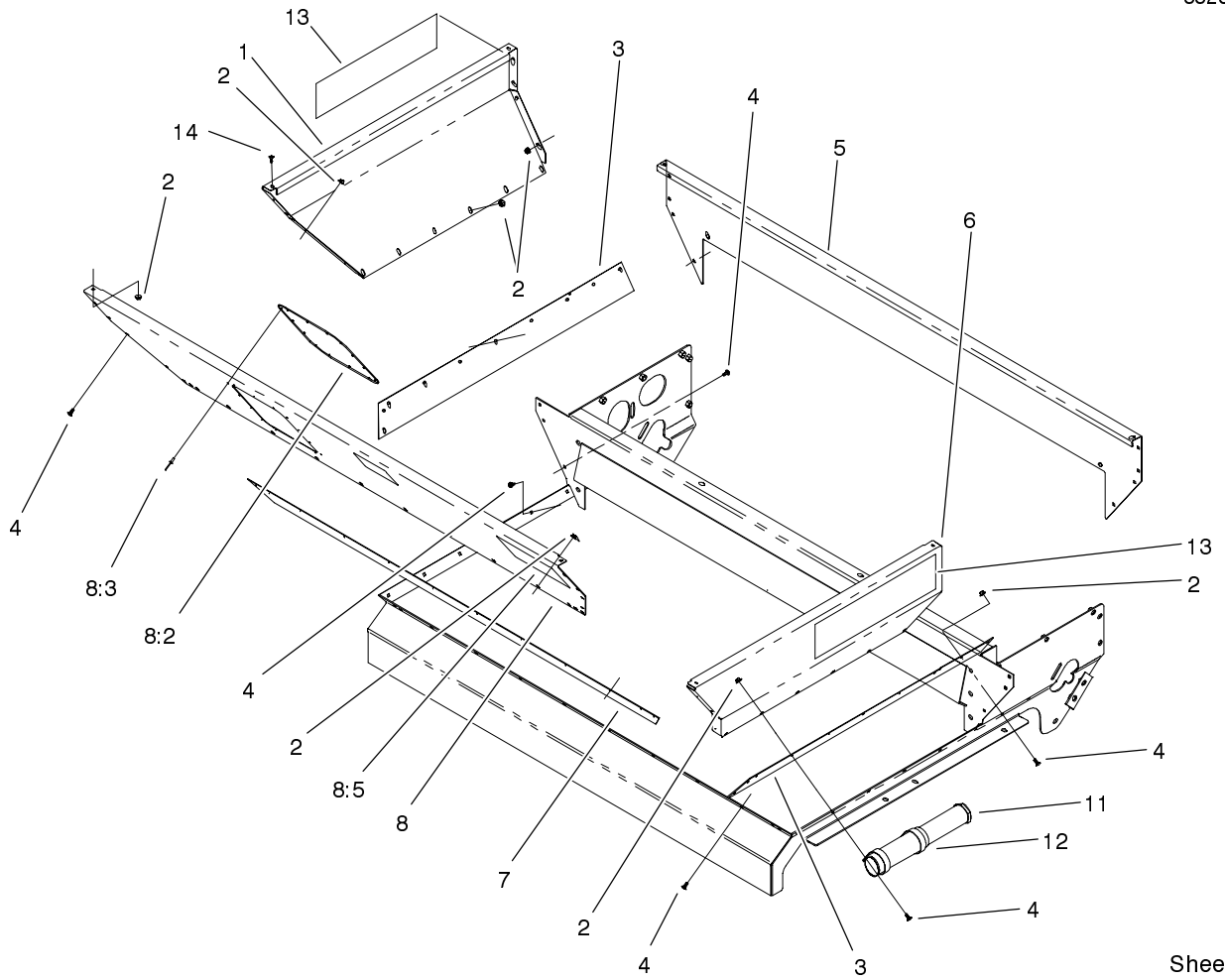

Sheet No.:9

# Hopper Assembly

Ref. No.	Part No.	Qty.	Description
1	99-0123	1	Panel-Hopper, RH
2	32128-33	48	Nut-HF
3	99-0142	2	Seal-Sand, Side
4	3229-25	44	Screw-CARR
5	99-0121	1	Panel-Hopper, Back
6	99-0124	1	Panel-Hopper, LH
7	99-0143	1	Seal-Sand, Front
8	100-1465	1	Front Hopper Panel ASM
8:2	99-0120	1	Hopper-Window
8:3	3269-28	14	Rivet-Pop
8:5	99-0016	1	Decal-Danger
11	74-0720	1	Tube-Manual
12	2412-133	2	R-Clamp
13	99-0012	2	Decal-2500 Topdresser
14	321-4	4	Screw-HH

Ref. No.	Part No.	Qty.	Description

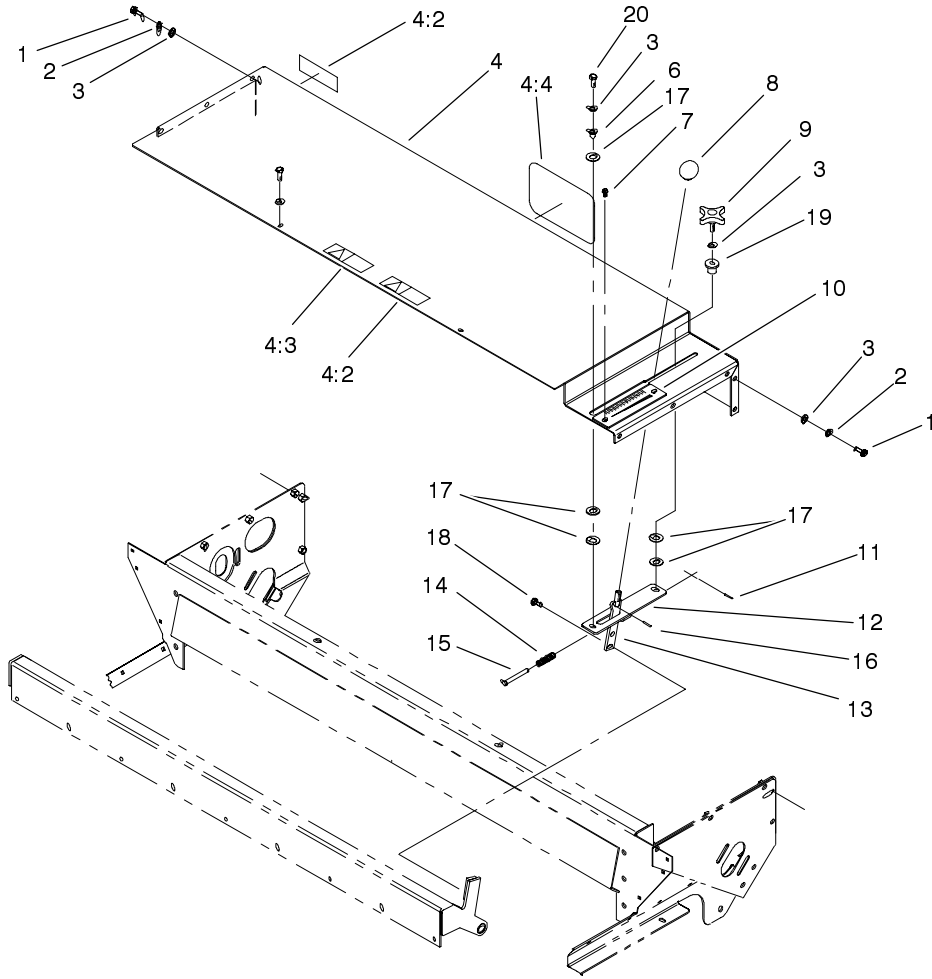

Sheet No.:10

## Gate Slide and Brush Guard Assembly

Ref. No.	Part No.	Qty.	Description
1	323-7	12	Screw-HH
2	3253-21	12	Washer-Lock
3	3256-24	14	Washer-Flat
4	100-1432	1	Brush Guard ASM
4:2	99-0015	2	Decal-Danger
4:3	93-9867	1	Decal-No Riders
4:4	92-1242	1	Decal-Toro
6	256-259	1	Bushing-Flange
7	93-6083	2	Screw-HWH
8	233-48	1	Knob
9	100-1449	1	Knob
10	100-1416	1	Plate-Gate
11	32121-45	1	Pin-Spring
12	99-0073-03	1	Slide Block Plate ASM
13	100-1406-03	1	Gate Handle ASM
14	100-1448	1	Spring-Gate
15	100-1413	1	Pin-Clevis
16	32121-40	1	Pin-Spring
17	99-0052	5	Washer-Slide
18	323-4	2	Screw-HH
19	95-4896	1	Washer-Nylon
20	3274-63	1	Screw-HSH

Ref. No.	Part No.	Qty.	Description

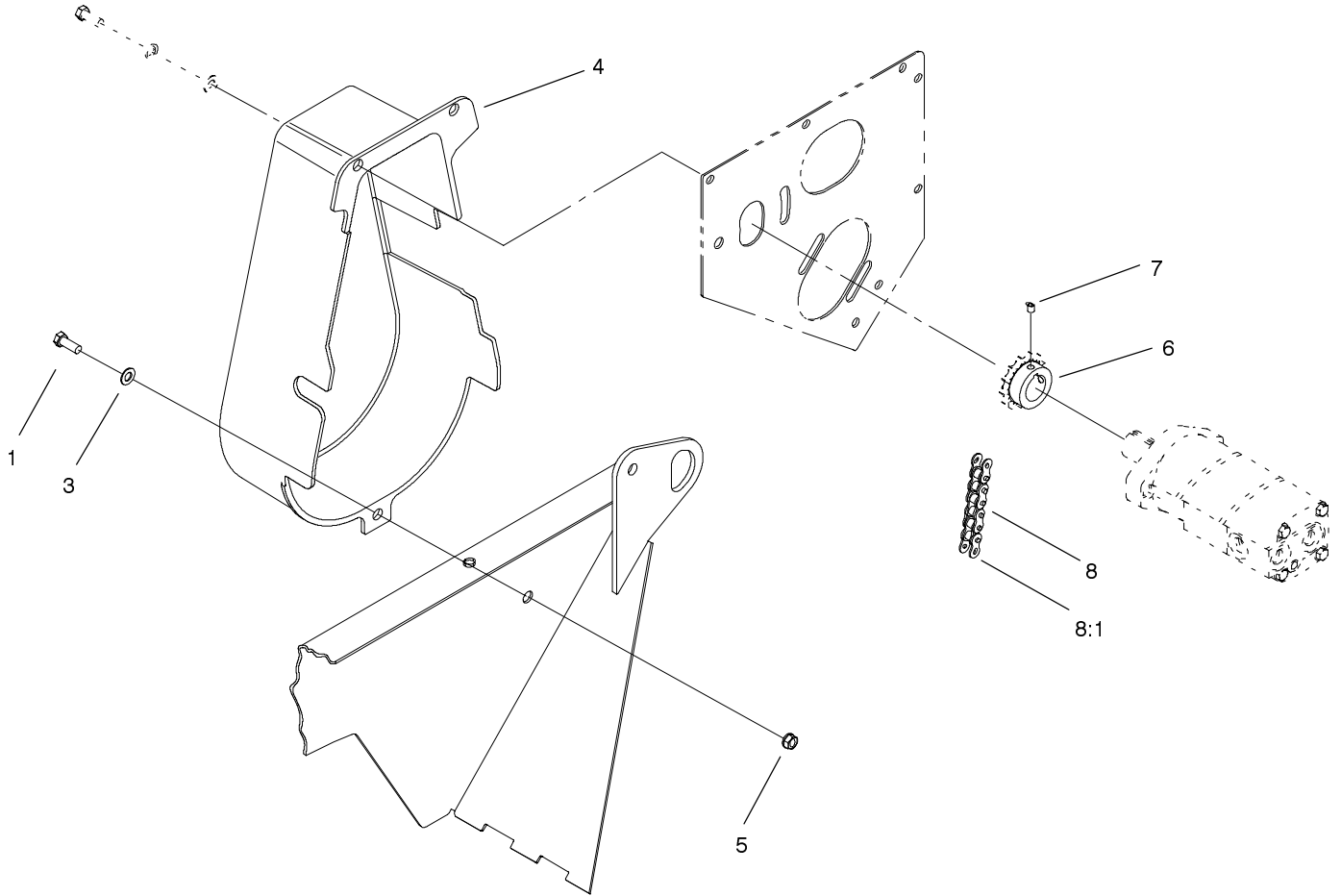

Sheet No.:11

## Chain, Sprocket and Guard Assembly

Ref. No.	Part No.	Qty.	Description
1	323-5	1	Screw-HH
3	3256-24	1	Washer-Flat
4	99-0171	1	Guard-Chain & Sprockets
5	3296-39	1	Nut-Lock, NI
6	99-0165-03	1	Sprocket-Drive
7	3246-3	2	Screw-HS
8	99-0164	1	Chain-Roller
8:1	2710-16	1	Link-Chain

Ref. No.	Part No.	Qty.	Description

# Hydraulic Schematic

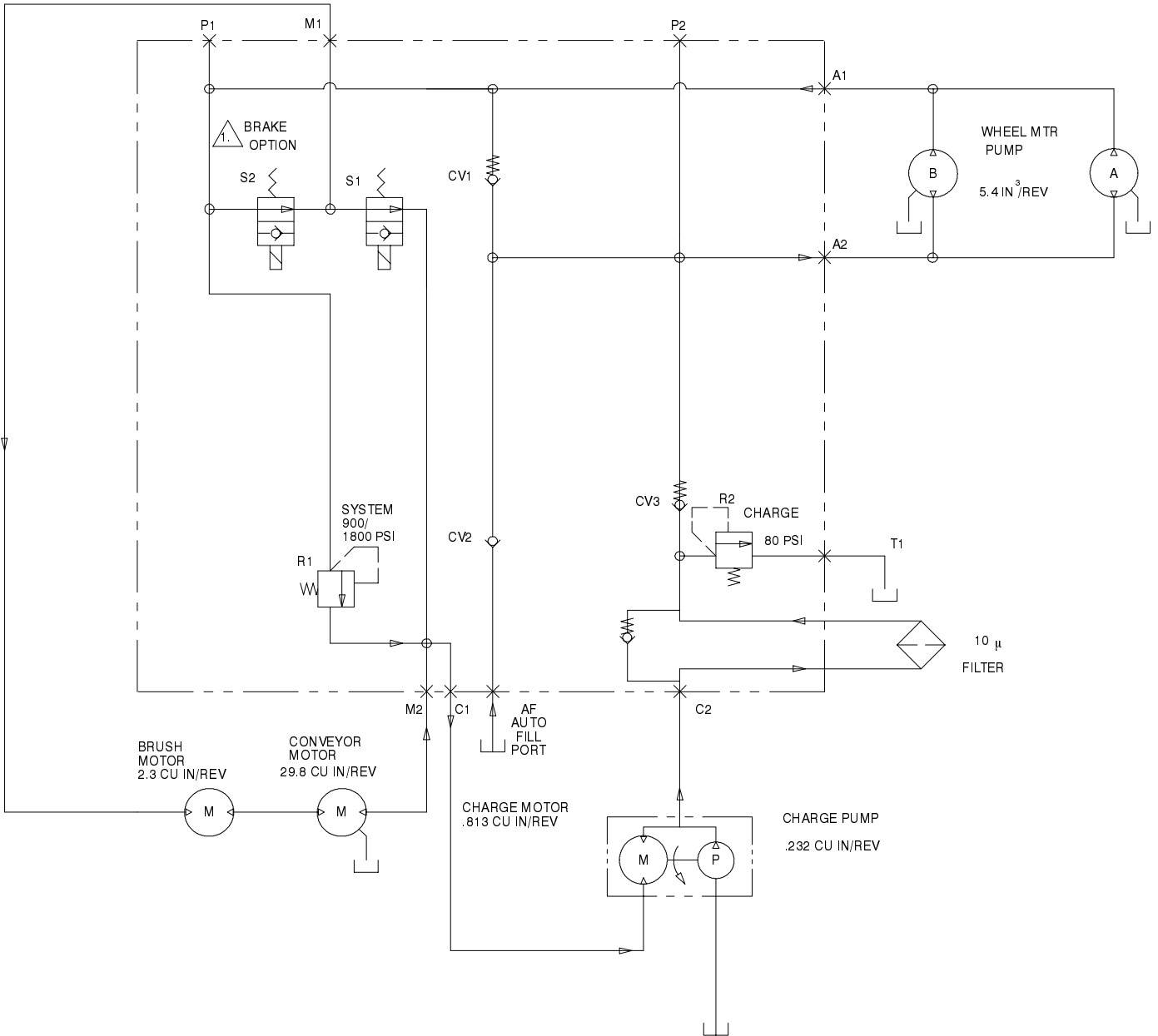

# Electrical Schematic

