



## **8 and 11 Blade Cutting Units**

### **Greensmaster<sup>®</sup> 3250**

**Model No. 04472—21000001 and Up**

**Model No. 04473—21000001 and Up**

**Operator's Manual**

# Contents

	Page
Introduction .....	2
Optional Equipment .....	2
Adjustments .....	3
Adjusting the Bedknife to the Reel .....	3
Choosing Cutting Unit Attitude .....	3
Leveling the Front Roller to the Reel .....	4
Adjusting the Top Shield Height .....	5
Adjusting the Top Bar .....	5
Adjusting the Height of Cut .....	5
Operation .....	6
Cutting Unit Characteristics .....	6
Daily Adjustments of Cutting Unit .....	6
Maintenance .....	6
Greasing the Bearings and Bushings .....	6
Backlapping the Cutting Units .....	7
The Toro General Commercial Products Warranty ..	8

## Introduction

Read this manual carefully to learn how to operate and maintain your product properly. The information in this manual can help you and others avoid injury and product damage. Although Toro designs and produces safe products, you are responsible for operating the product properly and safely.

Whenever you need service, genuine Toro parts, or additional information, contact an Authorized Service Dealer or Toro Customer Service and have the model and serial numbers of your product ready. Figure 1 illustrates the location of the model and serial numbers on the product.

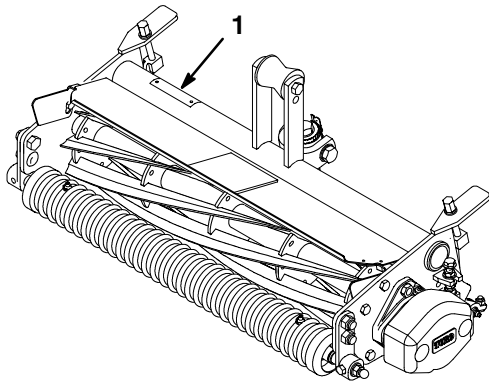

**Figure 1**

1. Location of the model and serial numbers

Write the product model and serial numbers in the space below:

<b>Model No.</b> _____
<b>Serial No.</b> _____

This manual identifies potential hazards and has special safety messages that help you and others avoid personal injury and even death. **Danger**, **Warning**, and **Caution** are signal words used to identify the level of hazard. However, regardless of the hazard, be extremely careful.

**Danger** signals an extreme hazard that *will* cause serious injury or death if you do not follow the recommended precautions.

**Warning** signals a hazard that *may* cause serious injury or death if you do not follow the recommended precautions.

**Caution** signals a hazard that may cause minor or moderate injury if you do not follow the recommended precautions.

This manual uses two other words to highlight information. **Important** calls attention to special mechanical information and **Note**: emphasizes general information worthy of special attention.

## Optional Equipment

Extended Micro Cut Bedknife	Part No. 104-7720
Lo Cut Bedknife	Part No. 93-4264
High Cut Bedknife	Part No. 94-6392
Fairway Bedknife	Part No. 94-6393
5 Blade Heavy Duty Reel	Part No. 98-2181
8 Blade Heavy Duty Reel	Part No. 98-2182
High Height-of-Cut Kit	Part No. 99-1496
Wiehle Rear Roller	Model No. 04488
Rear Roller Scraper Kit	Part No. 95-1600
Groomer	Model No. 04485
Rear Roller Brush Kit (for use with Groomer Model No. 04485)	Model No. 04491
Rear Roller Brush Kit	Model No. 04489
Front Roller Scraper/Brush	Part No. 104-7731

**Note:** Specifications and design subject to change without notice.

# Adjustments

**Note:** Determine the left and right sides of the machine from the normal operating position.

After the cutting unit is unboxed, use the following procedures to ensure that the cutting units are adjusted properly.

1. Check each end of the reel for grease. Grease should be visibly evident in the reel bearings.
2. Ensure that all nuts and bolts are securely fastened.
3. Position the lift roller to match the suspension.
  - Upper position for standard transport height
  - Lower position for increased transport height
4. Check to make sure that the bedknife and reel are parallel; refer to Adjusting the Bedknife to the Reel, page 3.

## Adjusting the Bedknife to the Reel

1. Remove cutting units from traction unit and position on a level work surface.
2. Make sure reel contact is removed by turning bedknife adjustment knob counterclockwise (Fig. 2).

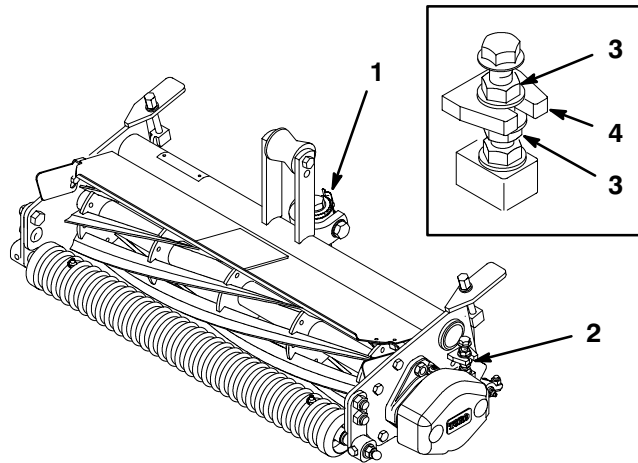
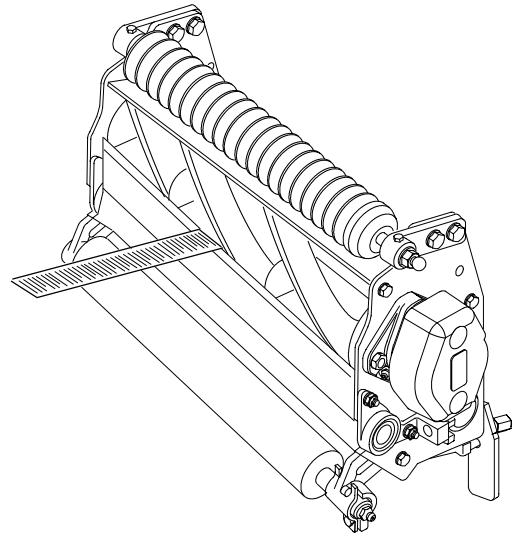

**Figure 2**

- |                                   |                |
|-----------------------------------|----------------|
| 1. Bedknife adjustment knob       | 3. Flange nuts |
| 2. Left-hand bedbar pivot housing | 4. Frame tab   |

3. On either end of front side of reel, insert a long strip of newspaper between the reel and bedknife (Fig. 3). While slowly rotating the reel forward, turn the bedknife adjusting knob clockwise, one click at a time, until the paper is pinched lightly on one end of the reel, which results in a slight drag when the paper is pulled.

4. Loosen locknuts retaining the left-hand bedbar pivot housing (Fig. 2).
5. Rotate flange nuts (Fig. 2, inset), on top and bottom of frame tab, clockwise or counterclockwise to raise or lower end of bedbar, as required. Do not loosen bottom flange nut. Tighten flangenuts against frame tab when desired adjustment is attained.
6. Check adjustments by repeating steps 2 and 3.
7. When light contact on paper is evident at each end of bedknife, tighten locknuts retaining pivot housing securely.



**Figure 3**

## Choosing Cutting Unit Attitude

There are four positions for the front roller brackets.

### Position 1

Least aggressive; use for very soft and tender turf.

HOC Range: 0.094 (3/32)-0.84 (27/32) in. (2.4-21.3 mm)

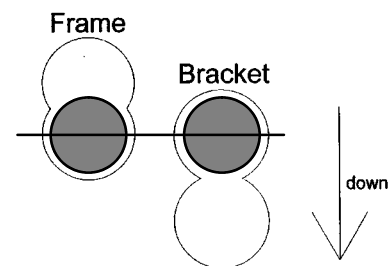

**Position 1**

## Position 2

Standard position; use for most conditions (factory setting).

HOC Range: 0.094 (3/32)-0.72 (23/32) in. (2.4-18.3 mm)

**Note:** The top frame hole and top bracket hole will yield Position 2 (standard position).

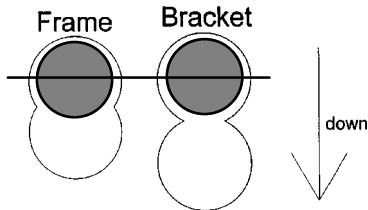

Position 2

## Position 3

More aggressive; use on firm turf or higher height-of-cuts.

HOC Range: 0.094 (3/32)-0.62 (5/8) in. (2.4-15.7 mm)

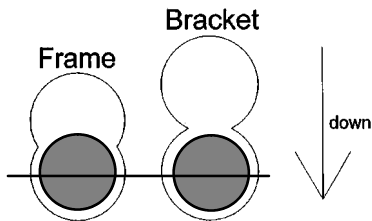

Position 3

## Position 4

Most aggressive; use only on very firm greens or at the higher height-of-cuts.

HOC Range: 0.094 (3/32)-0.50 (1/2) in. (2.4-12.7 mm)

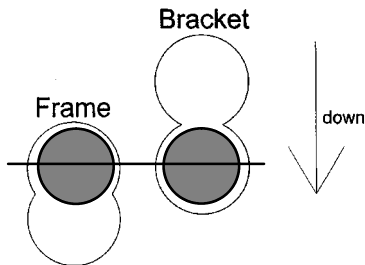

Position 4

**Note:** A more aggressive setting will increase grass removal and provide a cleaner cut, but may cause increased scalping and marking.

**Note:** A more aggressive setting may be required to compensate for reel wear. (As the reel wears, the cutting unit becomes less aggressive).

## Leveling the Front Roller to the Reel

1. Position the cutting unit on a flat, level surface.
2. Place a 1/4 inch or thicker plate under the reel blades and against the front face of the bedknife.

**Note:** Be sure that the plate covers the full length of the reel blades and three blades contact the plate.

3. Loosen the locknuts retaining the right front roller bracket (Fig. 4).

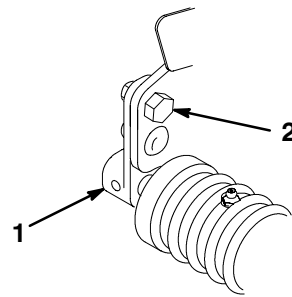

Figure 4

1. Right front roller bracket
2. Upper right roller mounting bolt

4. While holding the reel securely on the plate and maintaining pressure on the front roller, rotate the upper right roller mounting bolt (Fig. 4). This mounting bolt has an offset, which when rotated, acts as an eccentric (cam) to raise or lower the roller. On the bolt head there is an I.D. dot which denotes the offset of the bolt. The dot indicates in which direction the right end of the roller moves when the bolt is turned.

**Note:** If additional adjustment is required, replace one screw on the left-hand bracket with another eccentric bolt, Part No. 93-2573. Ensure that both front roller brackets are in the same hole.

5. To verify if the roller is level, try inserting a piece of paper under each end of the roller.
6. When the roller is level, tighten the nuts securely.

## Adjusting the Top Shield Height

1. Loosen bolts and nuts securing the shield to each side plate.
2. Adjust the shield to the desired position and secure the fasteners.
3. Repeat this procedure on the remaining cutting units and adjust the top bar.

**Note:** The shield can be raised for extremely wet conditions.

## Adjusting the Top Bar

Adjust the top bar, under the rear shield, to ensure that clippings are cleanly discharged from the reel area.

1. Loosen the screws securing the top bar. Insert a 0.06 in. (1.5 mm) feeler gauge between the top of the reel and bar and tighten the screws. Ensure that the bar and reel are an equal distance apart across the complete reel.
2. Repeat the settings on the remaining cutting units.

**Note:** The bar is adjustable to compensate for changes in turf conditions. The bar should be adjusted closer to the reel when the turf is extremely wet. By contrast, adjust the bar further away from the reel when turf conditions are dry. The bar should be adjusted whenever the top shield height is changed.

## Adjusting the Height of Cut

1. Verify that the front roller is level and the bedknife-to-reel contact is correct.
2. Turn the cutting unit over (90°) and rest it on the rear roller and top rear tabs. Loosen the locknuts on the bolts retaining the rear roller brackets (Fig. 5).

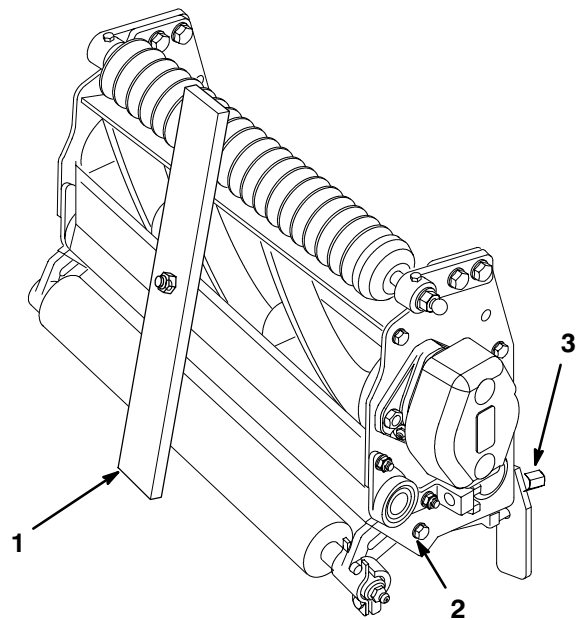

**Figure 5**

1. Gauge bar
2. Roller bracket bolt
3. Height-of-cut knob

3. On the gauge bar (Part No. 13-8199), set the head of the screw to the desired height of cut (Fig. 5). This measurement is from the bar face to the underside of the screw head.
4. Place the bar across the front and rear rollers and adjust the height-of-cut knob (Fig. 5) until the underside of the screw head engages the bedknife cutting edge.

**Important** Repeat this procedure on each end of the bedknife and tighten the locknuts retaining the rear roller brackets on each end.

**Note:** The cutting units will deliver differing effective height of cuts depending on their configuration. Effective cutting height may be influenced by the following factors: turf conditions, roller profiles, cutting unit attitude, cutting unit accessories, weight of cutting units, and bedknife profile. Therefore, benchsetting a cutting unit does not equal the effective (actual) height of cut you achieve. You need to determine how to adjust your cutter on the bench to achieve a comparable height of cut to a cutting unit of a different configuration, model, or brand.

# Operation

**Note:** Determine the left and right sides of the machine from the normal operating position.

## Cutting Unit Characteristics

The single knob bedknife-to-reel adjustment system incorporated in this cutting unit simplifies the adjustment procedure needed to deliver optimum mowing performance. The precise adjustment possible with the single knob/bedbar design gives the necessary control to provide a continual self-sharpening action—thus maintaining sharp cutting edges, ensuring good quality-of-cut, and greatly reducing the need for routine backlapping.

## Daily Adjustments of Cutting Unit

Prior to mowing each day, or as required, each cutting unit must be checked to verify proper bedknife-to-reel contact. **This must be performed even though quality of cut is acceptable.**

1. Lower the cutting units onto a hard surface, shut off the engine, and remove the ignition key.
2. Slowly rotate the reel in a reverse direction, listening for reel-to-bedknife contact. If no contact is evident, turn the bedknife adjusting knob clockwise, one click at a time, until light contact is felt and heard.

**Note:** The adjustment knob has detents corresponding to .0007 in. (.018 mm) bedknife movement for each indexed position.

3. If excessive contact is felt, turn the bedknife adjusting knob counterclockwise, one click at a time until no contact is evident. Then turn the bedknife adjusting knob one click at a time clockwise, until light contact is felt and heard.

**Important** Light contact is preferred at all times. If light contact is not maintained, the bedknife/reel edges will not sufficiently self-sharpen and dull cutting edges will result after a period of operation. If excessive contact is maintained, bedknife/reel wear will be accelerated, uneven wear can result, and quality of cut may be adversely affected.

**Note:** As the reel blades continue to run against the bedknife, a slight burr will appear on the front cutting edge surface along the full length of the bedknife. If a file is occasionally run across the front edge to remove this burr, improved cutting can be obtained.

After extended running, a ridge will eventually develop at both ends of the bedknife. These notches must be rounded off or filed flush with the cutting edge of the bedknife to ensure smooth operation.

# Maintenance

**Note:** Determine the left and right sides of the machine from the normal operating position.

## Greasing the Bearings and Bushings

Each cutting unit has 7 grease fittings that must be lubricated regularly with No. 2 General Purpose Lithium Base Grease.

The grease fitting locations and quantities are:

- Bedknife pivot (Fig. 6)
- Reel bearings (2) (Fig. 6)
- Front and rear rollers (2 ea.) (Fig. 6)

**Important** Lubricating the cutting units immediately after washing helps purge water out of the bearings and increases bearing life.

1. Wipe each grease fitting with a clean rag.
2. Apply grease until pressure is felt against the handle.

**Important** Do not apply too much pressure or the grease seals will be permanently damaged.

3. Wipe excess grease away.

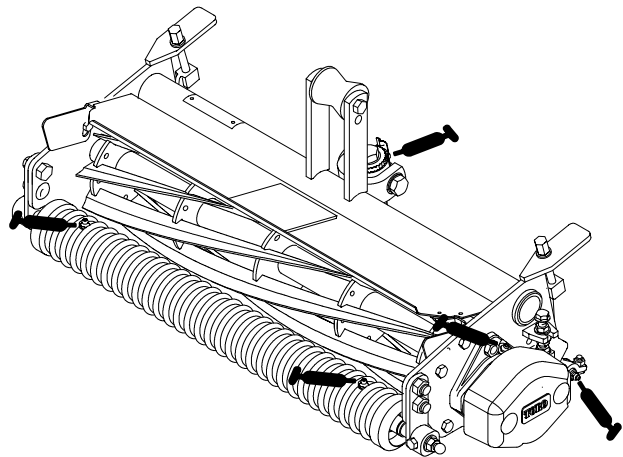

Figure 6

## Backlapping the Cutting Units



### Caution



**Contact with the reels or other moving parts can result in personal injury.**

**Keep fingers, hands, and clothing away from the reels or other moving parts.**

1. Position the machine on a clean, level surface, lower the cutting units, stop the engine, engage the parking brake, and remove the ignition key.
2. Remove the reel motors from the cutting units and disconnect and remove the cutting units from the lift arms.
3. Connect the backlapping machine to the cutting unit by inserting a piece of 3/8 in. square stock into the splined coupling at the right end of the cutting unit.

**Note:** Additional instructions and procedures on Backlapping are available in the Toro Sharpening Reel & Rotary Mowers Manual, Form No. 80-300PT.

**Note:** For a better cutting edge, run a file across the front face of the bedknife when the lapping operation is completed. This will remove any burrs or rough edges that may have built up on the cutting edge.



# The Toro General Commercial Products Warranty

## A Two-Year Limited Warranty

### Conditions and Products Covered

The Toro Company and its affiliate, Toro Warranty Company, pursuant to an agreement between them, jointly warrant your 1996 or newer Toro Commercial Product ("Product") purchased after January 1, 1997, to be free from defects in materials or workmanship for two years or 1500 operational hours\*, whichever occurs first. Where a warrantable condition exists, we will repair the Product at no cost to you including diagnosis, labor, parts, and transportation. This warranty begins on the date the Product is delivered to the original retail purchaser.

\* Product equipped with hour meter

### Instructions for Obtaining Warranty Service

You are responsible for notifying the Commercial Products Distributor or Authorized Commercial Products Dealer from whom you purchased the Product as soon as you believe a warrantable condition exists.

If you need help locating a Commercial Products Distributor or Authorized Dealer, or if you have questions regarding your warranty rights or responsibilities, you may contact us at:

Toro Commercial Products Service Department  
Toro Warranty Company  
8111 Lyndale Avenue South  
Bloomington, MN 55420-1196  
952-888-8801 or 800-982-2740  
E-mail: commercial.service@toro.com

### Owner Responsibilities

As the Product owner, you are responsible for required maintenance and adjustments stated in your operator's manual. Failure to perform required maintenance and adjustments can be grounds for disallowing a warranty claim.

### Items and Conditions Not Covered

Not all product failures or malfunctions that occur during the warranty period are defects in materials or workmanship. This express warranty does not cover the following:

- Product failures which result from the use of non-Toro replacement parts, or from installation and use of add-on, modified, or unapproved accessories
- Product failures which result from failure to perform required maintenance and/or adjustments
- Product failures which result from operating the Product in an abusive, negligent or reckless manner
- Parts subject to consumption through use unless found to be defective. Examples of parts which are consumed, or used up, during normal Product operation include, but are not limited to, blades, reels, bedknives, tines, spark plugs, castor wheels, tires, filters, belts, etc.

### Countries Other than the United States or Canada

Customers who have purchased Toro products exported from the United States or Canada should contact their Toro Distributor (Dealer) to obtain guarantee policies for your country, province, or state. If for any reason you are dissatisfied with your Distributor's service or have difficulty obtaining guarantee information, contact the Toro importer. If all other remedies fail, you may contact us at Toro Warranty Company.

- Failures caused by outside influence. Items considered to be outside influence include, but are not limited to, weather, storage practices, contamination, use of unapproved coolants, lubricants, additives, or chemicals, etc.
- Normal "wear and tear" items. Normal "wear and tear" includes, but is not limited to, damage to seats due to wear or abrasion, worn painted surfaces, scratched decals or windows, etc.

### Parts

Parts scheduled for replacement as required maintenance are warranted for the period of time up to the scheduled replacement time for that part.

Parts replaced under this warranty become the property of Toro. Toro will make the final decision whether to repair any existing part or assembly or replace it. Toro may use factory remanufactured parts rather than new parts for some warranty repairs.

### General Conditions

Repair by an Authorized Toro Distributor or Dealer is your sole remedy under this warranty.

**Neither The Toro Company nor Toro Warranty Company is liable for indirect, incidental or consequential damages in connection with the use of the Toro Products covered by this warranty, including any cost or expense of providing substitute equipment or service during reasonable periods of malfunction or non-use pending completion of repairs under this warranty. Except for the Emissions warranty referenced below, if applicable, there is no other express warranty. All implied warranties of merchantability and fitness for use are limited to the duration of this express warranty.**

Some states do not allow exclusions of incidental or consequential damages, or limitations on how long an implied warranty lasts, so the above exclusions and limitations may not apply to you.

This warranty gives you specific legal rights, and you may also have other rights which vary from state to state.

**Note regarding engine warranty:** The Emissions Control System on your Product may be covered by a separate warranty meeting requirements established by the U.S. Environmental Protection Agency (EPA) and/or the California Air Resources Board (CARB). The hour limitations set forth above do not apply to the Emissions Control System Warranty. Refer to the Engine Emission Control Warranty Statement printed in your operator's manual or contained in the engine manufacturer's documentation for details.