



MODEL NO. 04450-30001 -
80001 & UP
MODEL NO. 04468-30001 -
80001 & UP

OPERATOR'S
MANUAL

GREENSMASTER 3000[®] CUTTING UNIT

Since this operator's manual covers only a minimal amount of information necessary to maintain and operate your machine, we suggest that you keep this material with your Traction Unit Operator's Manual so that both may be referred to for instructions concerning safe operation and proper maintenance procedures.

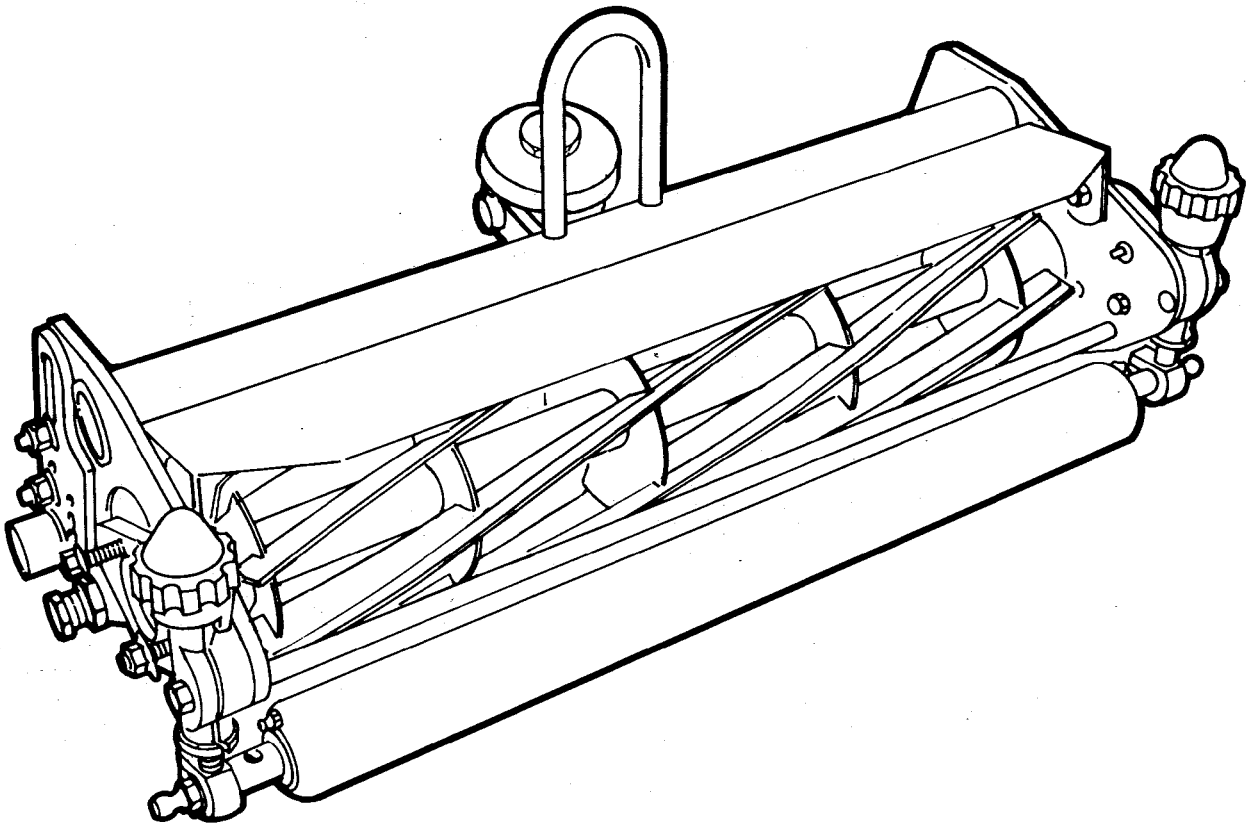

TABLE OF CONTENTS

	Page		Page
LOOSE PARTS	2	OPERATING INSTRUCTIONS	6
SPECIFICATIONS	2	LUBRICATION	7
KNOW YOUR CUTTING UNIT	2	MAINTENANCE AND ADJUSTMENTS	7-10
SETTING UP INSTRUCTIONS	3-6	Reel Lapping	7
Leveling Rear Roller To Reel	3-4	Removing Bedknife	7
Adjusting Height-of-Cut	5	Parallel Bedknife to Reel	8
Adjusting Brush Assembly	5	Preparing Reel for Grinding	9
Front Roller Scraper Adjustment	5	Servicing and Adjusting Reel Bearings	9
Adjusting Shield Height	5	Removal of Reel Assembly	10
Adjusting Top Bar	6	MAINTENANCE RECORD	11-12
		TORO PROMISE	12

LOOSE PARTS

DESCRIPTION	QTY	USE
Ball Stud	2	Mount Front Roller
Internal Tooth Lockwasher-3/8	2	
Scraper/Brush	1	Mount to Front Roller
Hex Nut	4	
Internal Tooth Lockwasher	4	
Flange Locknut	2	Mount Reel Drive Motor to Cutting Unit
Shipment Trace Card	1	
Registration Card	1	

SPECIFICATIONS

Height-of-Cut: 3/32 (.094) in. to 3/4 (.75) in.

Power: Hydraulic motor splined to reel shaft.

Roller Adjustment:

Front: Micrometer hand adjustment with bolted clamp lock (1 turn = 0.025 in. height of cut change).

Rear: Roller brackets allow adjustment for different height of cuts. Single screw adjustment to ease in leveling.

Bearings: Timken tapered roller.

Bedknife & Bedbar: Single edge high carbon steel knife attached to a cast bedbar; single screw adjustment with eccentric bedbar leveling.

Bedknife to Reel Adjustment: Bedknife adjusts against reel, with positive adjustment control knob located at center of bedbar. Adjustment knob contains

a detent with .001 inch movement of bedknife for each indexed position. Pivot point at top of bedbar is greasable.

Options;

Swaged Roller Kit: Model No. 04414

Full Roller Kit: Model No.04412

Wiehle Roller Kit: Model No. 04424

Aluminum Wiehle Roller Kit: Model No. 04426

Low Height of Cut Bedknife: Part No. 63-8470

High Cut Bedknife: Part No. 62-2500

Tournament Bedknife: Part No. 63-8560

Fairway Bedknife: Part No. 63-8600

Basket Reinforcement Kit: Part No. 26-0900

Scraper Comb Assembly: Part No. 11-0070

Bearing Replacement Tool Kit: Part No. 23-8900

Rear Roller Scraper Kit: Part No. 53-9240

Quick Height of Cut Kit: Model No. 04451

KNOW YOUR CUTTING UNIT

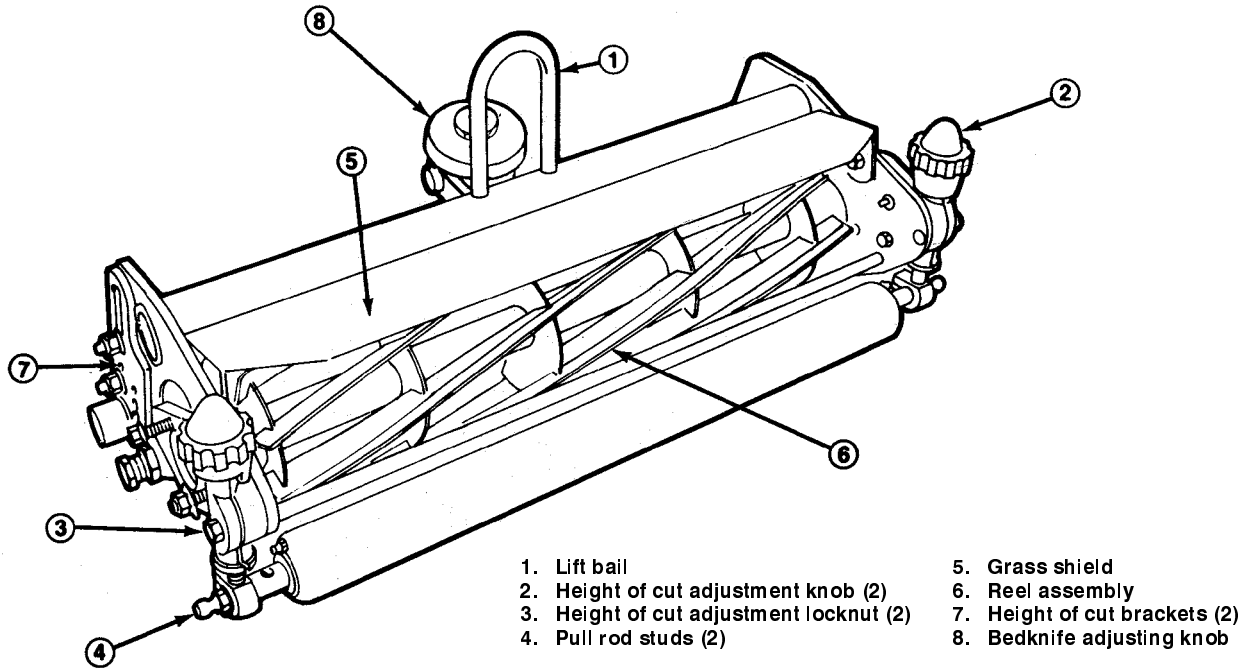

- | | |
|-----------------------------------------|-------------------------------|
| 1. Lift bail | 5. Grass shield |
| 2. Height of cut adjustment knob (2) | 6. Reel assembly |
| 3. Height of cut adjustment locknut (2) | 7. Height of cut brackets (2) |
| 4. Pull rod studs (2) | 8. Bedknife adjusting knob |

SETTING UP INSTRUCTIONS

IMPORTANT: Read the Operator's Manual thoroughly for setting up instructions. Failure to do so may result in damage to the cutting unit.

Note: Left and right sides of cutting unit refer to normal operating position.

1. The cutting unit is shipped without a front roller. Install roller using loose parts supplied with cutting unit and instructions included with roller.
2. Retain (2) flange nuts supplied in loose parts for mounting reel drive motor to cutting unit.
3. Check for looseness in the bearings between the end plate and reel by moving reel laterally or axially on each end of Cutting Unit. Refer to Servicing and Adjusting the Reel Bearing, page 9.

4. Check to make sure bedknife and reel are parallel. On either end of front side of cutting unit insert a long strip of newspaper between reel blade and bedknife. Slowly rotate reel and turn bed-knife adjusting knob (using a wrench) (Fig. 1) clockwise one click at a time, until paper is pinched lightly, which results in a slight drag when paper is pulled. Check opposite end for light contact using paper. If light contact is not evident at both ends, bedknife is not parallel to reel. Refer to Parallel Bedknife to Reel, page 8.

LEVELING REAR ROLLER TO REEL

1. Position Cutting Unit on a flat, level surface.
2. Assemble rear Height of Cut brackets to desired position. Loosen top capscrew and nut and remove bottom nut and bolt on right and left hand sides of cutting unit (Fig. 2).

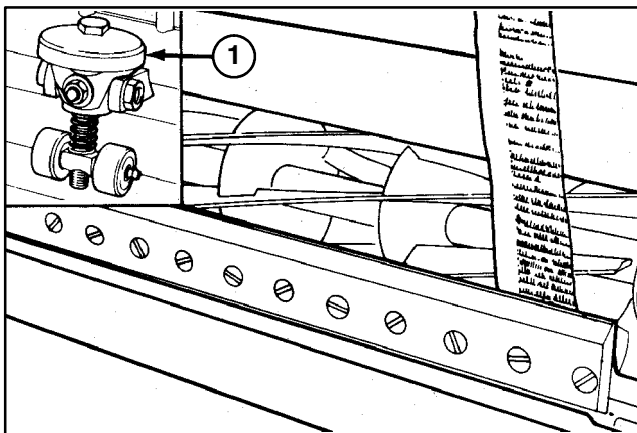

Figure 1
1. Bedknife adjusting knob

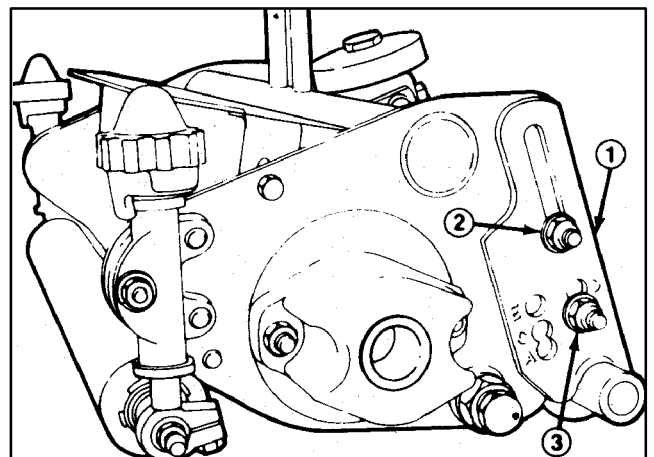

Figure 2
1. Rear height of cut bracket
2. Top capscrew and nut
3. Bottom nut

SETTING UP INSTRUCTIONS

3. Slide bolts thru each bracket until brackets can be realigned with appropriate mounting hole. See table (Fig. 3) for proper position on brackets.

Note: The various rear roller bracket positioning holes (B thru E) are designed to optimize bedknife location for different heights of cut.

To determine the correct hole setting, find the desired height of cut in the chart below and note the recommended hole position letter. The typical height of cut values can be used as a guide.

Typical Height of Cut -inch	Recommended Rear Roller Bracket Hole Positions	Height of Cut Ranges - inch
1/8 (.125)	B	3/32 - 1/4 (.094 - .250)
1/4 (.250)	C	3/16 - 3/8 (.187 - .375)
3/8 (.375)	D	1/4 - 1/2 (.250 - .500)
1/2 (.500)	E	3/8 - 3/4 (.375 - .750)

Table - Figure 3

Note: For most typical greens mowing, the best rear roller location is usually the "C" position.

The height of cut ranges listed have more than one possible hole position. It may be necessary to deviate outside the above suggested ranges if grass conditions warrant.

4. After positioning into correct height-of-cut hole position, install flatwashers and nuts and securely tighten the right hand rear roller bracket capscrews (Fig. 4).

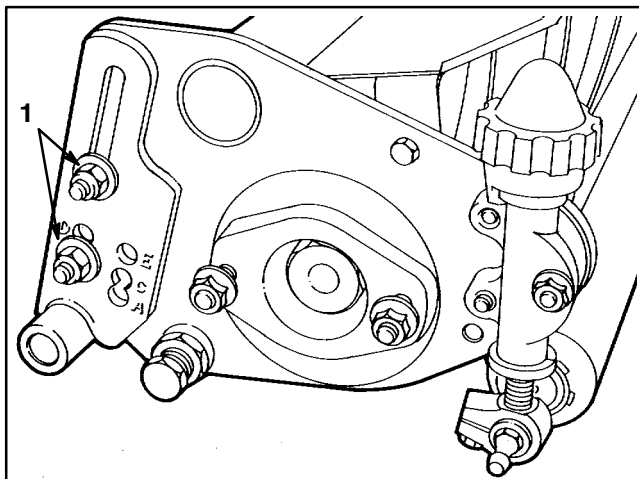

Figure 4

1. Right rear roller bracket capscrews

5. Left hand rear roller bracket capscrews are to be tightened only enough to remove excessive looseness in assembly, but allow bracket to slide freely on side plate.

6. Position a 1/4 inch or thicker plate under the reel blades and against the front face of the bed-knife (Fig. 5).

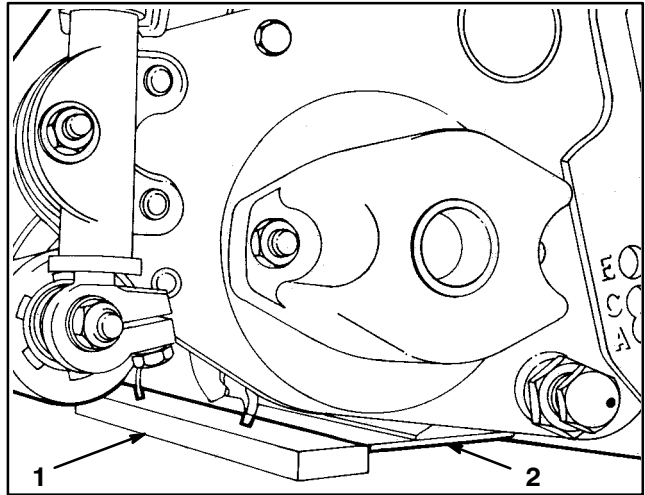

Figure 5

1. 1/4" plate
2. Bedknife

Note: Be sure that the plate covers the full length of reel blades, and (3) blades contact plate.

7. While holding reel securely on plate, level roller by rotating lower left roller pivot bolt. The pivot bolt has an offset thread which when rotated, acts as a cam to raise or lower the roller. On the bolt head there is an identification dot (Fig. 6) which denotes the offset of the bolt. Dot indicates in which direction left end of roller moves when bolt is turned.

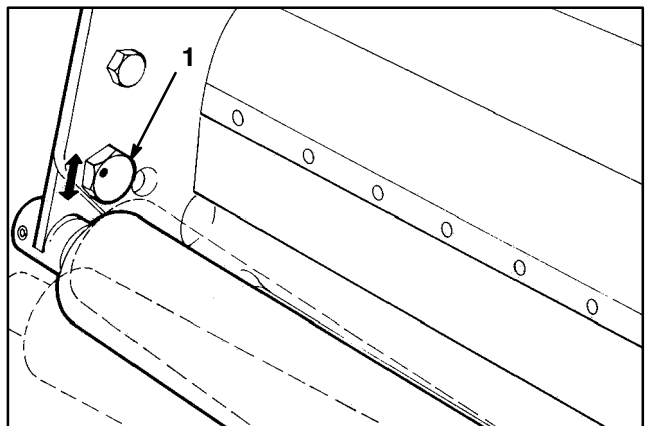

Figure 6

1. Pivot bolt

8. To verify if roller is level, try inserting a piece of paper under each end of roller.

9. When roller is level, tighten left capscrew and pivot bolt securely.

SETTING UP INSTRUCTIONS

ADJUSTING HEIGHT OF CUT

1. Verify the rear roller brackets are in the correct hole positions corresponding with desired height of cut and that rear roller is level. Also, check that bedknife to reel contact is correct. (See Table – Fig. 3).
2. Turn cutting unit over and loosen locknuts securing front roller adjusting screws to Height of Cut brackets (Fig. 7).

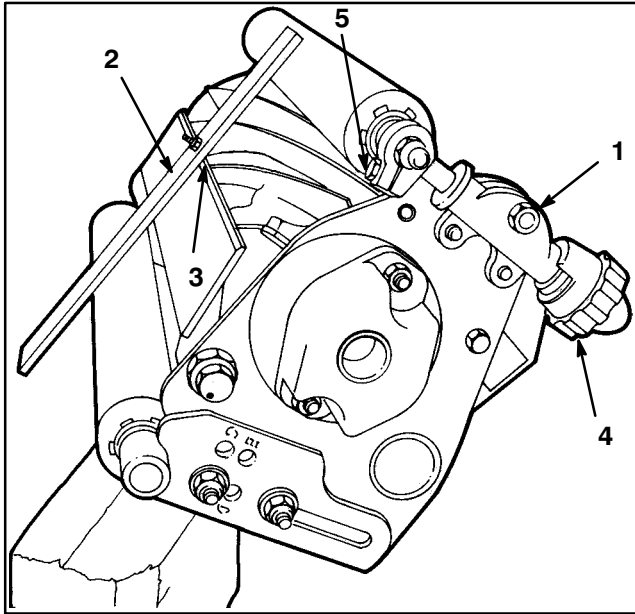

Figure 7

1. Height of cut knob locknut
2. Gauge bar (13-8199)
3. Gauge bar screw head
4. Height of cut knob
5. Roller shaft clamp bolt

3. On gauge bar (Part no.13-8199), set head of screw to desired height of cut. This measurement is from bar face to underside of screw head.

4. Place the bar across the front and rear rollers and adjust the height of cut knob until the underside of screw head engages the bedknife cutting edge (Fig. 7).

IMPORTANT: Do procedure No.4 on each end of bedknife and retighten height of cut adjustment locknuts on each end.

ADJUSTING BRUSH ASSEMBLY

To adjust the brush assembly, proceed as follows:

1. Assure rear roller is in the desired height of cut position. Loosen the bolts anchoring the front roller shaft. Rotate the shaft (Fig. 7).
2. To adjust the aggressiveness of the brush, proceed as follows:
 - A. Bristle touching the adjusting gauge bar give you an aggressive setting.

B. Adjusting the brush assembly so it is midway between the adjusting gauge bar and the cutting edge of the bedknife will provide a medium setting.

C. Adjusting the brush assembly so it is even with the cutting edge of the bedknife will provide a light setting.

Note: Securing one end of the brush assembly at a time simplifies the above procedure.

3. Tighten the roller shaft bolts (Fig.).

FRONT ROLLER SCRAPER ADJUSTMENT

The front roller scraper should be adjusted so there is a clearance of approximately 1/32 of an inch between the scraper and roller.

ADJUSTING SHIELD HEIGHT

Adjust shield to assure proper grass clipping discharge into basket:

1. Set cutting unit in normal cutting position and measure distance from top of front crossbar to shield at each end of cutting unit (Fig. 8).

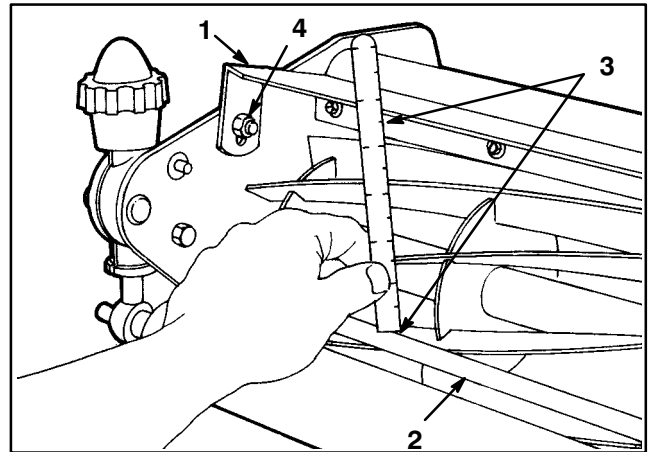

Figure 8

1. Shield
2. Front crossbar
3. 4-3/4 inches
4. Shield fasteners

2. Height of shield from crossbar for normal cutting conditions should be 4-3/4 inches. Loosen capscrews and nuts securing shield to each side-plate, adjust shield to correct height and tighten fasteners (Fig. 8).

3. Repeat adjustment on remaining cutting units and adjust top bar: refer to Adjusting Top Bar, page 6.

Note: Shield can be lowered in dry grass conditions • (clippings fly over top of baskets) or raised to allow for heavy wet grass conditions (clippings build up on rear edge of baskets).

SETTING UP INSTRUCTIONS

ADJUSTING TOP BAR

Adjust top bar to assure clippings are cleanly discharged from reel area:

1. Loosen screws securing top bar (Fig. 9). Insert 0.060 inch feeler gauge between top of reel and bar and tighten screws (Fig. 9). Assure bar and reel are equal distance apart across complete reel.
2. Repeat settings on remaining cutting units.

Note: Bar is adjustable to compensate for changes in turf conditions. Bar should be adjusted closer to reel when turf is extremely wet. By contrast, adjust bar further away from reel when turf conditions are dry. Bar should be parallel to reel to assure optimum performance and should be adjusted whenever shield height is adjusted or whenever reel is sharpened on a reel grinder.

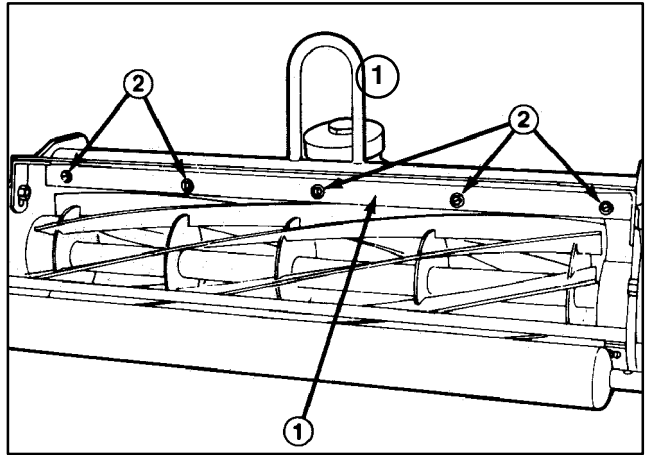

Figure 9

1. Top bar
2. Bar mounting screws

OPERATING INSTRUCTIONS

FUNCTIONAL CHARACTERISTICS

The single knob bedknife to reel adjustment system incorporated in this cutting unit simplifies the adjustment procedure needed to deliver optimum greens mowing performance. The precise adjustment possible with the single knob bedbar design gives the necessary control to provide a continual self-sharpening action – thus maintaining sharp cutting edges, assuring good quality-of-cut, and greatly reducing the need for routine backlapping.

In addition, the rear roller positioning system permits optimum bedknife attitude and location for varying height-of-cuts and turf conditions.

DAILY ADJUSTMENTS

Prior to each day's mowing, or as required, each cutting unit must be checked to verify proper bedknife-to-reel contact. This must be performed even though quality of cut is acceptable.

1. Shut off engine and lower cutting units onto a hard surface.
2. Remove grass baskets.
3. On each cutting unit, loosen (2) flange nuts securing reel motor to cutting unit.
4. Twist motor clockwise to disengage from cutting unit and remove motor.

5. Slowly rotate reel in reverse direction listening for reel-to-bedknife contact. If no contact is evident, turn bedknife adjusting knob clockwise, one click at a time, until light contact is felt and heard.

6. If excessive contact is felt, turn bedknife adjusting knob counterclockwise, one click at a time until no contact is evident. Then turn bedknife adjusting knob one click at a time clockwise, until light contact is felt and heard.

7. Reassemble motor to cutting unit.

IMPORTANT: Light contact is preferred at all times. If light contact is not maintained, bedknife/ reel edges will not sufficiently self-sharpen and dull cutting edges will result after a period of operation. If excessive contact is maintained, bedknife/reel wear will be accelerated, uneven wear can result, and quality of cut may be adversely affected.

Note: As the reel blades continue to run against the bedknife a slight burr will appear on the front cutting edge surface the full length of the bedknife. If a file is occasionally run across the front edge to remove this burr, improved cutting can be obtained.

After extended running, notches will eventually develop at both ends of the bedknife. These notches rounded off or filed flush with cutting edge of bedknife to assure smooth operation.

LUBRICATION

There are seven (7) grease fittings on each cutting unit (Fig. 10 & 11), which should be greased at least once every two weeks. Lubricate using a No. 2 multipurpose lithium base grease. A hand operated grease gun is recommended for best results.

1. Wipe each grease fitting with a clean rag.
2. Grease reel bearings as follows:
 - A. Hydraulic motor end; apply grease until pressure is felt against handle.

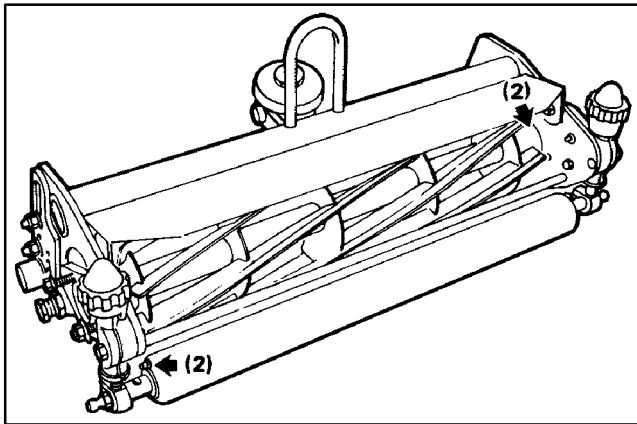

Figure 10

- B. Counterbalance end; apply grease until it starts to come through seal inside counter balance hole.

3. Apply grease to front and rear roller bearings until it begins to show around seal lips.

IMPORTANT: Do not apply too much pressure or grease seals will be permanently damaged.

4. Apply grease to pivot points.
5. Wipe excess grease away.

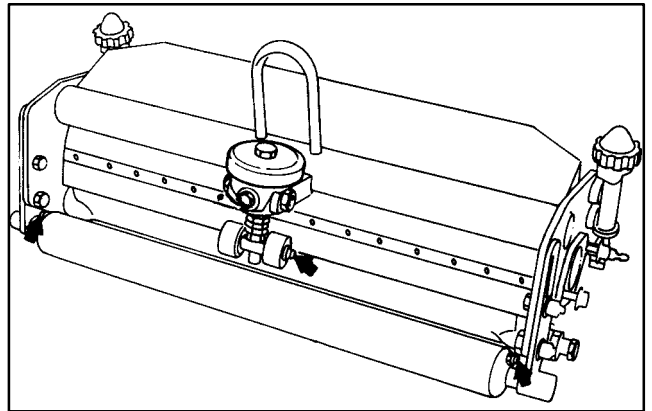

Figure 11

MAINTENANCE AND ADJUSTMENTS

IMPORTANT: Reel motors must be removed before removing the cutting units to prevent hose damage due to twisting, bending, and kinking.

REEL LAPPING

Connect a lapping machine to the cutting unit with an extension coupler, and a 9/16 socket. The 9/16 socket can be positioned onto the capscrew on the reel shaft inside the counter – balance weight on the end of the cutting unit. Backlap according to procedures in the TORO Sharpening Reel & Rotary Mowers Manual Form No. 80–300PT.

Note: For a better cutting edge, run a file across the front face of the bedknife when the lapping operation is completed. This will remove any burrs or rough edges that may have built up on the cutting edge.



CAUTION

Be careful when lapping the reel because contact with the reel or other moving parts can result in personal injury.

REMOVING BEDKNIFE

IMPORTANT: Before removing cutting unit, remove reel motors to prevent damaging hydraulic hoses.

1. Remove spring arm retaining capscrew and washer from pivot assembly. Loosen pivot screws securing bedknife pivot assembly to reel frame supports (Fig. 12).

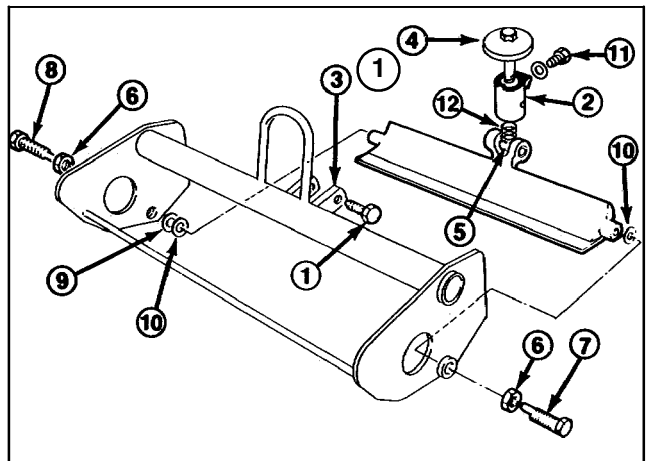

Figure 12

- | | |
|----------------------------|-----------------------------------|
| 1. Pivot screw | 7. Left bedbar pivot bolt |
| 2. Bedknife pivot assembly | 8. Right bedbar pivot bolt |
| 3. Reel frame supports | 9. Steel washer |
| 4. ADjustment knob | 10. Plastic washer |
| 5. Bedbar pivot | 11. Spring arm retaining capscrew |
| 6. Jam nuts | 12. Compression spring |

2. Rotate adjustment knob and pivot assembly clockwise (left hand thread) until it is unthreaded from bedbar pivot (Fig. 12).

MAINTENANCE AND ADJUSTMENTS

3. Loosen jam nuts retaining right and left bed-bar pivot bolts. Remove pivot bolts (Fig. 12).

IMPORTANT: Note position of plastic washer and steel washer on right end of bedbar, and plastic washer on left end of bedbar for reinstallation.

4. Slide bedbar down and out from under cutting unit. Do not misplace washers.

5. Adjust reel bearings, then grind the reel to remove any taper and renew cutting edges.

Note: For proper grinding of bedknife, grind in accordance with procedures in the TORO Sharpening Reel and Rotary Mowers Manual, Form No. 80-300 PT.

6. To reinstall, slide bedbar into position between sideplates making sure each end of bedbar is under shield (Fig. 13).

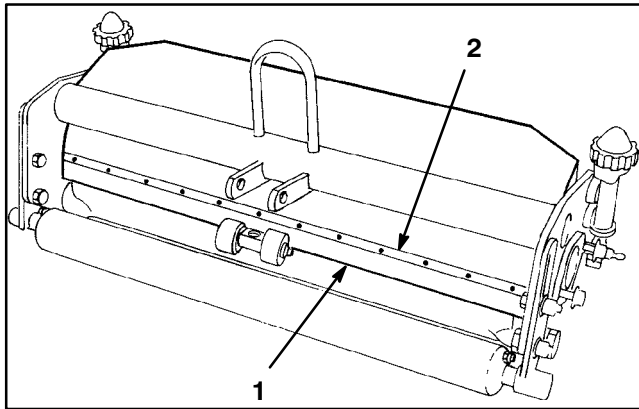

Figure 13

1. Bedbar
2. Shield

Note: To ease assembly of bedbar to sideplates, steps 7 & 8, start assembly of both ends before completing installation.

IMPORTANT: Always use McLUBE (Toro Part No. 505-35) on bedbar pivot and pivot bolts.

7. Mount left side of bedbar to sideplate with eccentric pivot bolt, jam nut and plastic washer. Position washer between bedbar and sideplate. Thread pivot bolt into bedbar until the distance from top of pivot bolt and sideplate is 1-5/16" with identification dot positioned to rear. Do not tighten jam nut at this time (Fig. 14).

8. Mount right side of bedbar to sideplate with shoulder bolt, jam nut, steel washer, and plastic washer. Position washers between bedbar and side-plate with plastic washer closest to bedbar. Adjust shoulder bolt (right hand) until left end of bedbar assembly firmly seats against left side plate, clamping the plastic washer tightly - thus all end-play is removed from bedbar. Bedbar must pivot without binding, with bedknife adjusting knob and pivot assembly not installed. Tighten jam nut while holding shoulder bolt (Fig. 12).

8

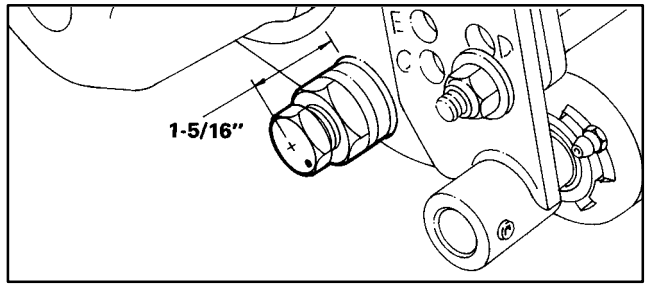

Figure 14

Note: Locate identification mark on bedknife pivot assembly (dot is to be closest to compression spring).

Note: Make sure adjustment knob screw thread and flat of center bedbar pivot are properly aligned before assembly, to prevent cross threading.

IMPORTANT: Apply NEVER-SEEZ to the threads of the handle assembly.

9. Thread adjustment knob and pivot assembly into flat side of bedbar pivot until mounting holes in pivot assembly are aligned with holes in reel frame supports and bedknife does not interfere with reel (Fig. 12).

10. Center pivot assembly between reel frame supports. Tighten pivot screws to 60 ft. lbs. Secure spring arm to pivot assembly.

11. After assembly of bedbar is complete, check to make sure bedknife and reel are parallel, refer to Parallel Bedknife to Reel, page 8.

PARALLEL BEDKNIFE TO REEL

1. Remove mower from traction unit and position on a level work surface. Make sure reel contact is removed by turning bedknife adjustment knob counterclockwise.

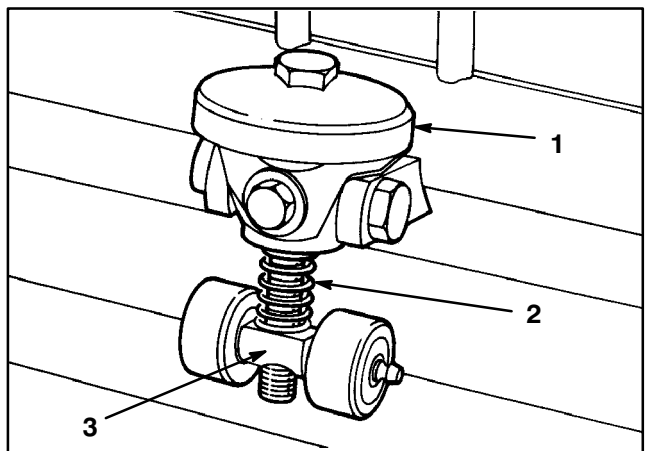

Figure 15

1. Bedknife adjusting knob
2. Compression spring
3. Pivot bar

MAINTENANCE AND ADJUSTMENTS

2. On either end of front side of reel, insert a long strip of newspaper between reel and bedknife. While slowly rotating reel forward, turn bedknife adjusting knob (Fig. 15) clockwise, one click at a time, until paper is pinched lightly, which results in a slight drag when paper is pulled.

3. Check for light contact at other end of reel using paper. If light contact is not evident at both ends, bedknife is not parallel to reel, proceed to step 4.

4. Loosen jam nut on left hand bedbar pivot bolt enough to ease in turning bolt. The left hand pivot bolt has an offset thread which, when rotated, acts as a cam to raise or lower the bedbar. On the bolt head there is an identification dot which denotes the offset of the bolt. When the dot is in the up position (Fig. 16) the left end of the bedbar is raised. As the bolt is turned clockwise and dot is lowered, so is the left end of the bedbar. Identification dot is to be positioned within the rear (180°) position when adjusting.

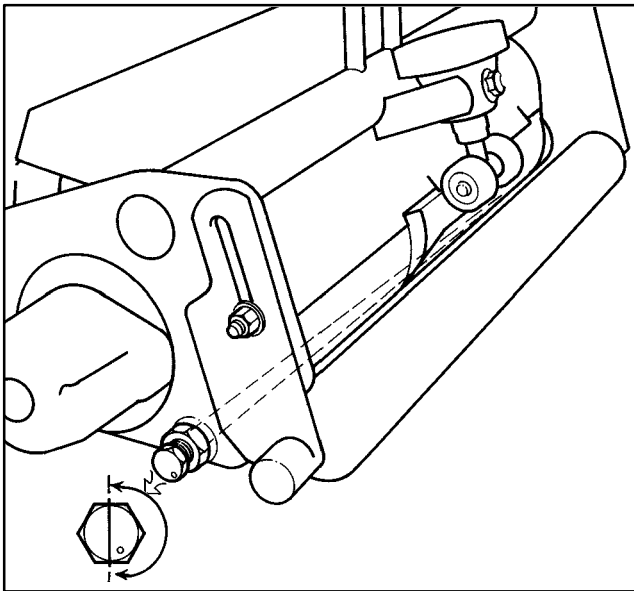

Figure 16

5. Rotate pivot bolt to raise or lower bedbar as required.

6. Check adjustments by repeating steps 1 and 2.

7. When light contact on paper is evident at each end of bedknife, tighten left hand jam nut while holding pivot bolt in position. Check to make sure pivot bolt did not become misadjusted when turning jam nut. Readjust as required.

PREPARING REEL FOR GRINDING

IMPORTANT: Before removing cutting unit, remove reel motors to prevent damaging hydraulic hoses.

The front roller may have to be removed so that the reel can be sharpened. To accomplish this, proceed as follows:

IMPORTANT: Some reel grinders may require that the rear roller assembly be mounted to the cutting unit for proper support in the reel grinder.

1. Loosen the locknuts securing the height of cut adjusting rods at both ends of the cutting unit and the roller shaft clamp bolts (Fig. 17).

2. Turn the height of cut adjustment knobs until they are disconnected from the height of cut adjusting rods (Fig. 17). The knobs are captivated on the upper washer face of height of cut clamp.

3. The roller assembly can then be removed from the cutting unit by pulling evenly on both sides.

4. For proper grinding of reel, grind in accordance with procedures in TORO Sharpening Reel & Rotary Mowers Form No. 80-300PT.

IMPORTANT: After grinding operation is complete, reassemble cutting unit, check bearing adjustment and adjust top shield and bar; refer to Adjusting Shield Height and Adjust Top Bar, pages 5 and 6. Back lap the cutting unit to complete sharpening operation.

SERVICING AND ADJUSTING THE REEL BEARINGS

IMPORTANT: Before removing cutting unit, remove reel motors to prevent damaging hydraulic hoses.

It is recommended that a check be made periodically of the drag on the reel bearings. The reel bearings can be checked and adjusted in the following manner:

1. First, make sure reel contact is removed by turning bedknife adjustment knob counterclockwise.

2. The reel bearing drag should be from 5 to 9 inch pounds. This can be measured with a torque wrench (Fig. 17).

Should you find the bearing drag does not meet the above specification, the procedure to adjust the reel bearing drag is as follows:

1. Remove the mounting nuts from the counterbalance end cap and remove end cap from the mounting studs (Fig. 17).

2. Remove bolt mounted on the end of reel shaft. This will make it possible for a large socket wrench to be mounted on the reel bearing adjusting nut inside the side plate.

MAINTENANCE AND ADJUSTMENTS

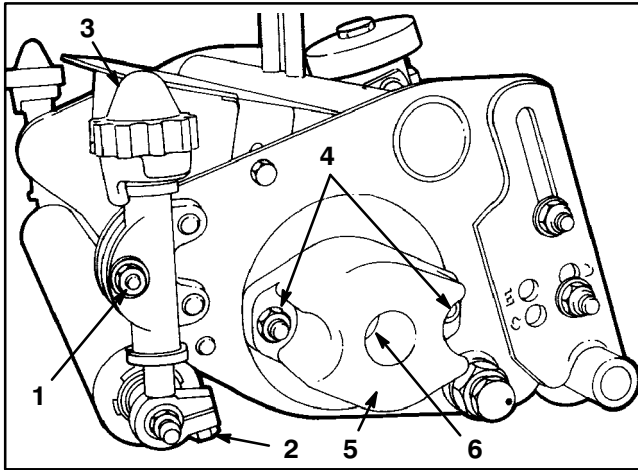

Figure 17

1. Height of cut locknut
2. Roller shaft clamp bolt
3. Height of cut knob
4. End cap mounting nuts
5. Counterbalance end cap
6. Reel bearing adjustment nut

3. With the wrench mounted, hold the reel and tighten the large reel bearing adjustment nut (Fig. 17). Tighten until the drag on the reel meets 5 to 9 inch–pound specification.

4. Reinstall bolt into end of the reel shaft and check the torque with an inch/pound torque wrench.

REMOVAL OF REEL ASSEMBLY

IMPORTANT: Before removing cutting unit, remove reel motors to prevent damaging hydraulic hoses.

To remove the reel assembly, proceed as follows:

1. Remove counterbalance End Cap (Fig. 17).
2. Remove the large bearing adjustment nut from one end of the reel shaft (Fig. 17) and the special spline nut at the opposite end of the reel shaft.

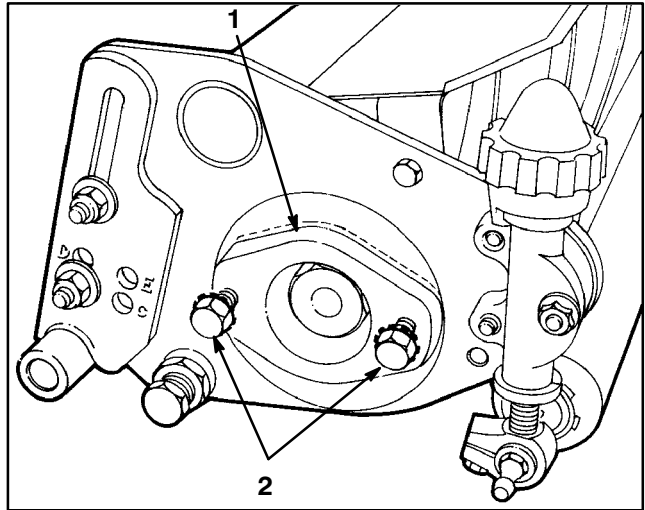

Figure 18

1. Bearing housing
2. Bearing housing mounting bolt

3. Remove the mounting bolts from the bearing housing; both ends of cutting unit (Fig. 18).

IMPORTANT: Remove grease fittings from the bearing housing at each end of the cutting unit. Note that the straight fitting is on the right end, and the 900 fitting at the left end (when viewed in the direction of travel).

4. Using a plastic headed hammer, rotate bearing housing slightly, install bearing housing bolts from outside housing, turn bolts alternately against side plate and use this method to remove bearing housing.

5. The bearing housing will slip out of the side plates and the reel assembly can be removed as soon as the bearing housings are disassembled from the side plates.

The Toro Promise

A One Year Limited Warranty

The Toro Company promises to repair your TORO product if defective in materials or workmanship. The following time periods from the date of purchase apply:

Commercial Products 1 Year

The cost of parts and labor are included, but the customer pays the transportation costs on walk rotary mowers with cutting unit widths of less than 25".

If you feel your TORO Product is defective and wish to rely on The Toro Promise, the following procedure is recommended:

1. Contact your Authorized TORO Distributor or Commercial Dealer (the Yellow Pages of your telephone directory is a good reference source).
2. The TORO Distributor or Commercial Dealer will advise you on the arrangements that can be made to inspect and repair your product.
3. The TORO Distributor or Commercial Dealer will inspect the product and advise you whether the product is defective and, if so, make all repairs necessary to correct the defect without an extra charge to you.

If for any reason you are dissatisfied with the distributor's analysis of the defect or the service performed, you may contact us.

Write:

TORO Commercial Products Service Department
8111 Lyndale Avenue South
Minneapolis, MN 55420

The above remedy of product defects through repair by an Authorized TORO Distributor or Commercial Dealer is the purchaser's sole remedy for any defect.

THERE IS NO OTHER EXPRESS WARRANTY. ALL IMPLIED WARRANTIES OF MERCHANTABILITY AND FITNESS FOR USE ARE LIMITED TO THE DURATION OF THE EXPRESS WARRANTY.

Some states do not allow limitations on how long an implied warranty lasts, so the above limitation may not apply to you.

This Warranty applies only to parts or components which are defective and does not cover repairs necessary due to normal wear, misuse, accidents, or lack of proper maintenance. Regular, routine maintenance of the unit to keep it in proper operating condition is the responsibility of the owner.

All warranty repairs reimbursable under The Toro Promise must be performed by an Authorized Toro Commercial Dealer or Distributor using Toro approved replacement parts.

Repairs or attempted repairs by anyone other than an Authorized TORO Distributor or Commercial Dealer are not reimbursable under the TORO Promise. In addition, these unauthorized repair attempts may result in additional malfunctions, the correction of which is not covered by warranty.

THE TORO COMPANY IS NOT LIABLE FOR INDIRECT, INCIDENTAL OR CONSEQUENTIAL DAMAGES IN CONNECTION WITH THE USE OF THE PRODUCT INCLUDING ANY COST OR EXPENSE OF PROVIDING SUBSTITUTE EQUIPMENT OR SERVICE DURING PERIODS OF MALFUNCTION OR NON-USE.

Some states do not allow the exclusion of incidental or consequential damages, so the above exclusion may not apply to you.

This warranty gives you specific legal rights, and you may also have other rights which vary from state to state.

COUNTRIES OTHER THAN THE UNITED STATES OR CANADA

Customers who have purchased TORO products exported from the United States or Canada should contact their TORO Distributor (Dealer) to obtain guarantee policies for your country, province, or state. If for any reason you are dissatisfied with your Distributor's service or have difficulty obtaining guarantee information, contact the TORO importer. If all other remedies fail, you may contact us at The Toro Company.