



MODEL NO. 30301 - 20000001 & UP
 MODEL NO. 30301TC - 20000001 & UP
 MODEL NO. 30302 - 20000001 & UP
 MODEL NO. 30302TC - 20000001 & UP

OPERATOR'S MANUAL

GROUNDMASTER® 3000-D

2 & 4 WHEEL DRIVE TRACTION UNITS

To understand this product, and for safety and optimum performance, read this manual before starting the engine. Pay special attention to SAFETY INSTRUCTIONS highlighted by this symbol.



It means CAUTION, WARNING or DANGER - personal safety instruction. Failure to comply with the instruction may result in personal injury.



The GROUNDMASTER 3000-D conforms to the B71.4-1990 specifications of the American National Standards Institute's safety standards for riding mowers: thus, TORO proudly displays the ANSI safety seal.



FOREWORD

This operator's manual has instructions on safety, proper set-up and operation, adjustments and maintenance. Therefore, anyone involved with the product, including the operator, should read and understand this manual.

Major sections are:

- Safety Instructions
- Specifications
- Set-up Instructions
- Before Operating
- Know Your Controls
- Operating Instructions
- Maintenance
- Schematics

This manual emphasizes safety, mechanical and general product information. **DANGER**, **WARNING** and **CAUTION** identify safety messages. Whenever the triangular safety alert symbol appears, understand the safety message that follows. For complete safety instructions, read pages 4-5. **IMPORTANT** highlights special mechanical information and **NOTE** emphasizes general product information worthy of special attention.

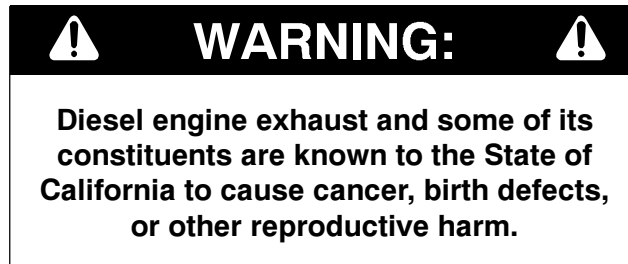

Whenever you have questions or need service, contact your local authorized Toro Distributor. In addition to having a complete line of accessories and professional turf care service technicians, the distributor has a complete line of genuine TORO replacement parts to keep your machine operating properly. Keep your TORO all TORO. Buy genuine TORO parts and accessories.

IDENTIFICATION AND ORDERING

MODEL AND SERIAL NUMBER

The model and serial number is on a plate that is mounted on the left side of operator platform behind footrest. Use model and serial number in all correspondence and when ordering parts.

To order replacement parts from an authorized TORO Distributor, supply the following information:

1. Model and serial numbers of the machine.
2. Part number, description and quantity of parts desired.

Note: Do not order by reference number if a parts catalog is being used; use the part number.

TABLE OF CONTENTS

	Page		Page
IDENTIFICATION & ORDERING	2	DAILY MAINTENANCE CHECKLIST	18
Model And Serial Number	2	MAINTENANCE SCHEDULE	19
SAFETY INSTRUCTIONS	4	AIR CLEANER MAINTENANCE	20
Before Operating	4	General Air Cleaner Maintenance	20
While Operating	4	Servicing Air Cleaner	20
Maintenance	5	ENGINE MAINTENANCE	21
SAFETY INSTRUCTIONS & DECALS	6	Engine Oil And Filter	21
SPECIFICATIONS	7	Fuel System	21
LOOSE PARTS CHART	8	Engine Cooling System	22
SET-UP INSTRUCTIONS	9	Engine Belts	22
Install Front and Rear Wheels	9	Service Spark Arrester Muffler	23
Install Steering Wheel	9	HYDRAULIC MAINTENANCE	24
Install Roll Bar	9	Changing Hydraulic System Oil and Filter ..	24
Grease Traction Unit	9	Checking Hydraulic Lines And Hoses	25
BEFORE OPERATING	10	Hydraulic System Test Port	25
Check Engine Oil	10	Adjusting Traction Drive Pedal Linkage	25
Check Cooling System	10	HYDRAULIC SCHEMATIC	26
Fill Fuel Tank	10	BRAKE MAINTENANCE	27
Check Hydraulic Fluid	11	Adjusting Service Brakes	27
Check Rear Axle Lubricant	11	AXLE MAINTENANCE	27
Check Tire Pressure	12	Changing Rear Axle Lubricant	27
Check Torque Of Wheel Nuts	12	Rear Wheel Toe-in	27
KNOW YOUR CONTROLS	13	ELECTRICAL MAINTENANCE	28
OPERATING INSTRUCTIONS	14	Battery Care	28
Starting And Stopping	14	Fuses	28
Priming Fuel System	14	ELECTRICAL SCHEMATIC	29
Checking Interlock Switches	14	PREPARATION FOR SEASONAL STORAGE .	30
Pushing or Towing Traction Unit	15	NOTES	31
Operating Characteristics	15	TORO PROMISE	Back Cover
LUBRICATION	19		
Greasing Bearings And Bushings	19		



SAFETY INSTRUCTIONS

The **GROUNDMASTER® 3000-D** was tested and certified by **TORO** for compliance with the **B71.4—1990** specifications of the **American National Standards Institute**. Although hazard control and accident prevention partially are dependent upon the design and configuration of the machine, these factors are also dependent upon the awareness, concern, and proper training of the personnel involved in the operation, transport, maintenance, and storage of the machine. **Improper use or maintenance of the machine can result in injury or death. To reduce the potential for injury or death, comply with the following safety instructions.**

BEFORE OPERATING

1. Read and understand the contents of this manual before starting and operating the machine. Become familiar with all controls and know how to stop quickly. A free replacement manual is available by sending complete Model and Serial Numbers to:

The Toro Company
8111 Lyndale Avenue South
Minneapolis, Minnesota 55420–1196

2. Never allow children to operate the machine. Do not allow adults to operate the machine without proper instruction. Only trained operators, skilled in slope operation and who have read this manual should operate this machine.

3. Never operate machine when under the influence of drugs or alcohol.

4. Remove all debris or other objects that might be picked up and thrown by cutter blades or fast moving components from other attached implements. Keep all bystanders away from the operating area.

5. Keep all shields and safety devices in place. If a shield, safety device, or decal is defective or damaged, repair or replace it before operation is commenced. Also, tighten any loose nuts, bolts, and screws to insure machine is in safe operating condition.

6. Do not wear loose-fitting clothing because it could get caught in moving parts. Always wear long pants and substantial shoes. Wearing safety glasses, safety shoes, and a helmet is advisable and required by some local ordinances and insurance regulations.

7. Check interlock switches daily for proper operation (Refer To Checking Interlock Switches, Page 14). Do not rely entirely on safety switches -shut off engine before getting off seat. If a switch fails, replace it before operating the machine. The interlock system is for your protection, so do not bypass it. Replace all interlock switches every two years. Interlock switches should be adjusted so:

A. Engine cannot be started unless traction pedal is released (neutral position).

B. Engine stops if operator gets off seat when traction pedal is depressed.

C. PTO disengages if operator gets off seat when PTO lever is ENGAGED (on position).

8. Fill fuel tank with diesel fuel before starting the engine. Avoid spilling any fuel. Since diesel fuel is flammable, handle it carefully.

A. Use an approved fuel container.

B. Do not fill fuel tank when engine is hot or running.

C. Do not smoke while handling fuel.

D. Fill fuel tank outdoors and up to about one inch (25 mm) from the top of the tank, not the filler neck.

E. Wipe up any spilled fuel.

9. Sit on the seat when starting the engine and operating the machine.

10. Always use seat belt and ROPS together. Make sure seat is latched.

11. Before starting the engine:

A. Engage parking brake.

B. Make sure traction pedal is in neutral.

C. After engine is started, release parking brake and keep foot off traction pedal. Machine must not move. If movement is evident, the neutral return mechanism is adjusted incorrectly. Shut engine off and adjust until machine does not move when traction pedal is released.

12. Do not run the engine in a confined area without adequate ventilation. Exhaust fumes are hazardous and could possibly be deadly.

13. Maximum seating capacity is one person. Therefore, never carry passengers.

14. This traction unit is intended to be used with an implement. Refer to implement operator's manual for sound and vibration information and rear weight requirements.

15. Check carefully for overhead clearances before driving under any objects.

WHILE OPERATING

16. Using the machine demands the operator's complete attention. To prevent loss of control:

A. Operate only in daylight or when there is good artificial light.

B. Drive slowly.

C. Avoid sudden stops and starts.

D. Look behind machine before backing up.

E. Watch for holes or other hidden hazards.

F. Do not drive close to a sand trap, ditch, creek, or hazard.

G. Reduce speed when making sharp turns and when turning on a hillside.

H. The cutting deck must be lowered when going down slopes for steering control.



SAFETY INSTRUCTIONS

17. Operator must be skilled and trained in how to drive on hillsides. Failure to use caution on slopes or hills may cause loss of control and vehicle to tip or roll possibly resulting in personal injury or death.

18. Traverse slopes carefully. Do not start or stop suddenly when traversing slopes or when traveling uphill or downhill.

19. Be certain seat belt can be removed quickly if machine is driven or rolls into ponds of water.

20. If engine stalls or machine loses headway and cannot make it to the top of a slope, do not turn machine around. Always back slowly straight down the slope.

21. This product is designed to drive objects into the ground where they lose energy quickly in grassy areas. However, don't take an injury risk!! When a person or pet appears unexpectedly in or near the mowing area, STOP MOWING. Careless operation, combined with terrain angles, ricochets, or improperly positioned guards, can lead to thrown object injuries. Do not resume mowing until area is cleared.

22. Never raise the cutting unit or other attached implement while the blades or other parts are rotating.

23. If cutting blades or other implement components strike a solid object or the machine vibrates abnormally, disengage PTO, move throttle to SLOW, set parking brake, and shut engine off. Remove key from switch to prevent possibility of accidental starting. Check cutting unit or other implement and traction unit for damage and defective parts. Repair any damage before restarting the engine and operating the implement or cutting unit. Assure cutting unit blades are in good condition and blade bolts are torqued to proper specifications (See Cutting Deck Operator's Manual).

24. To stop machine, remove foot from traction pedal and use brakes. Gradually reversing the traction pedal can provide additional braking.

25. Do not touch engine, muffler, or radiator while engine is running or soon after it has stopped. These areas could be hot enough to cause a burn.

26. Lower the cutting unit or other attached implement to the ground and remove key from switch whenever machine is left unattended.

27. Before getting off the seat:

A. Move traction pedal to neutral position and remove foot from pedal.

B. Set the parking brake and disengage the PTO.

C. Shut the engine off and remove key from ignition switch. Wait for all movement to stop before getting off the seat.

MAINTENANCE

28. Remove key from ignition switch to prevent accidental starting of the engine when servicing, adjusting, or storing the machine.

29. If major repairs are ever needed or assistance is desired, contact an Authorized TORO Distributor.

30. To reduce potential fire hazard, keep the engine free of excessive grease, grass, leaves, and accumulations of dirt. Never wash a warm engine or electrical connections with water.

31. If the cutting unit discharge area ever plugs, disengage PTO and shut engine off before removing the obstruction.

32. Make sure machine is in safe operating condition by keeping nuts, bolts, and screws tight. Check attachment mounting hardware and all cutting unit blade mounting bolts frequently to assure they are torqued to proper specifications (See Cutting Deck or attachment Operator's Manual).

33. Periodically inspect the roll bar and roll bar mounting. Repair, as necessary. Do not weld, cut, drill, or modify roll bar in any manner.

34. Make sure all hydraulic line connectors are tight, and all hydraulic hoses and lines are in good condition before applying pressure to the system.

35. Keep body and hands away from pin hole leaks or nozzles that eject hydraulic fluid under high pressure. Use paper or cardboard, not hands, to search for leaks. Hydraulic fluid escaping under pressure can have sufficient force to penetrate skin and do serious damage. If fluid is ejected into the skin, it must be surgically removed within a few hours by a doctor familiar with this form of injury or gangrene may result.

36. Before disconnecting or performing any work on the hydraulic system, all pressure in system must be relieved by stopping engine and lowering implement to the ground.

37. If the engine must be running to perform maintenance or an adjustment, keep clear of PTO shaft, cutting unit blades, and other moving parts.

38. Do not overspeed the engine by changing the governor settings. Maximum engine speed with no load is 2780 rpm. To ensure safety and accuracy, have an Authorized TORO Distributor check maximum engine speed with a tachometer.

39. Engine must be shut off before checking oil or adding oil to the crankcase.

40. At the time of manufacture, the machine conformed to safety standards in effect for riding mowers. To ensure optimum performance and continued safety certification of the machine, use genuine TORO replacement parts and accessories. Replacement parts and accessories made by other manufacturers may result in non-conformance with the safety standards, and the warranty may be voided.

SAFETY AND INSTRUCTION DECALS

The following safety and instruction decals are mounted on the traction unit. If any decal becomes damaged or illegible, install a new decal. Part numbers are listed below or in your parts catalog.

GROUNDMASTER 3000-D QUICK REFERENCE AID

CHECK/SERVICE (DAILY)

- ENGINE OIL LEVEL
- HYDRAULIC FLUID LEVEL
- ENGINE COOLANT LEVEL
- FUEL - DIESEL ONLY
- FUEL/WATER SEPARATOR
- FAN BELT TENSION
- RADIATOR SCREEN
- AIR CLEANER
- BRAKE FUNCTION
- INTERLOCK SYSTEM
- TIRE PRESSURE - 15 PSI / 1.05 BAR
- REAR AXLE OIL LEVEL - (4WD ONLY)
- GREASE POINTS (2WD-18, 4WD-23)

SPECIFICATIONS/CHANGE INTERVALS

SEE OPERATOR'S MANUAL FOR INITIAL CHANGES.	FLUID TYPE	CAPACITY	CHANGE INTERVAL FLUID	CHANGE INTERVAL FILTER	FILTER PART NO.
ENGINE OIL	15W-40 CE	4.75 QUARTS	100 HOURS	100 HOURS	74-7970
HYDRAULIC FLUID	MOBIL 424	12 QUARTS	600 HOURS	600 HOURS	94-3951
REAR AXLE - 4WD	MOBIL 424	1 QUART	600 HOURS		
INTERLOCK SWITCHES			2 YEARS		
COOLANT HOSES			1000 HOURS		
AIR CLEANER ELEMENT			1000 HOURS	1000 HOURS	94-1412
TIMING BELT			1500 HOURS		93-5720
FUEL SYSTEM	> 32° F NO. 2 DIESEL < 32° F NO. 1 DIESEL	12 GALLONS	800 HOURS 400 HOURS	400 HOURS	76-5220
ENGINE COOLANT	90% 93-7213 10% WATER	11.5 QUARTS	DRAIN & FLUSH, 1000 HOURS OR 2 YEARS, WHICHEVER OCCURS FIRST.		

* - DO NOT USE BIODEGRADABLE OIL IN TRANSAXLE OR 4WD AXLE

Next to Right Side of Seat
(Part No. 93-5934)

OPERATING INSTRUCTIONS

STARTING ENGINE:

- PLACE TRACTION PEDAL IN NEUTRAL POSITION.
- DEPRESS BRAKE PEDALS.
- SET ENGINE SPEED CONTROL TO LOW IDLE.
- TURN IGNITION KEY TO RUN POSITION, GLOW INDICATOR WILL LIGHT.
- WHEN GLOW INDICATOR DIMS, TURN IGNITION KEY TO START POSITION AND RELEASE.

STOPPING ENGINE:

- RETURN ENGINE SPEED CONTROL TO LOW IDLE.
- DISENGAGE IMPLEMENT.
- SET PARKING BRAKE.
- TURN IGNITION KEY TO OFF POSITION.
- REMOVE IGNITION KEY.

ENGAGE IMPLEMENT:

- LIFT SWITCH LEVER, PUSH FORWARD AND RELEASE.

DISENGAGE IMPLEMENT:

- PULL SWITCH LEVER REARWARD AND RELEASE.

GROUND SPEED (HIGH RANGE):

- RAISE IMPLEMENT COMPLETELY.
- DEPRESS SWITCH FORWARD AND RELEASE, TRANSPORT INDICATOR WILL LIGHT.

HIGH ENGINE TEMPERATURE OVERRIDE:

- DEPRESS AND HOLD BUTTON TO OVERRIDE HIGH ENGINE TEMPERATURE SHUTDOWN.

SEE OPERATOR'S MANUAL

On Fuse Compartment Cover
(Part No. 93-5930)

⚠ DANGER

ESTA MAQUINA PUEDE SER RIESGOSA SI SE USA EN UNA MANERA INAPROPIADA. OPERADORES DEBEN ESTAR MUY BIEN ENTRENADOS EN LA MANERA APROPIADA DE OPERAR LA MAQUINA.

TO MINIMIZE THE RISK OF ACCIDENTS, INJURY, OR DEATH:

- BEFORE LEAVING OPERATOR'S POSITION:
 - MOVE TRANSMISSION TO NEUTRAL
 - SET PARKING BRAKE
 - DISENGAGE POWER TAKE-OFF
 - SHUT OFF ENGINE
 - REMOVE IGNITION KEY
- KEEP ALL GUARDS AND COVERS IN PLACE
- WAIT FOR ALL MOVEMENT TO STOP BEFORE SERVICING.
- STOP ENGINE BEFORE LEAVING SEAT, ADDING FUEL OR LIFTING HOOD.
- KEEP PEOPLE AND PETS A SAFE DISTANCE AWAY.
- ALWAYS USE SEAT BELT AND ROLL-BAR TOGETHER AND HAVE SEAT PIVOT LATCHED.
- OPERATOR MUST BE SKILLED AND TRAINED IN SLOPE OPERATION. READ OPERATOR'S MANUAL.
- GO SLOW AND AVOID SHARP TURNS ON SLOPES TO AVOID ROLLOVER.
- DECK MUST BE LOWERED WHEN GOING DOWN SLOPES FOR STEERING CONTROL.

On Tool Box Cover
(Part No. 93-5621 - Model 30301)
(Part No. 93-5622 - Model 30302)

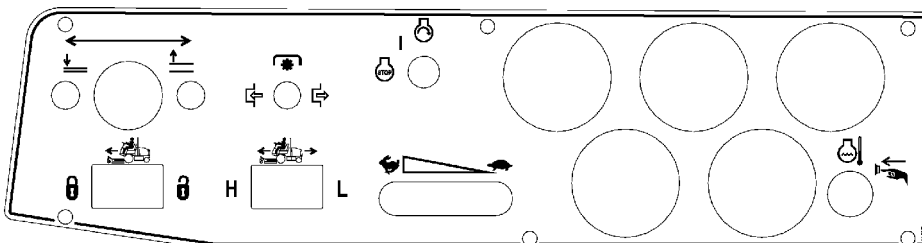

On Control Panel
(Part No. 93-5425)

⚠ CAUTION

CHECK PERFORMANCE OF ALL INTERLOCK SWITCHES DAILY. SEE OPERATOR'S MANUAL FOR INSTRUCTION. DO NOT DEFEAT INTERLOCK SYSTEM. IT IS FOR YOUR PROTECTION.

On Side of Tool Box
(Part No. 67-1710)

5A ACCORDARY KIT	STARTER 20A SOLENOID	HIGH COOLANT TEMP RELAY	TRANSPORT RELAY	IMPLEMENT FLOAT RELAY	CRUISE RELAY (OPTIONAL)
20A LIGHT KIT	PTO 20A (7/16/20)	START RELAY	PTO RELAY	SEAT RELAY	ENGINE SHUTDOWN DELAY RELAY
5A IMPLEMENT KIT	SEAT 7.5A SWITCH				
25A THERMAL BREAKER	IGNITION 10A SWITCH				

In Compartment Behind Control panel
(Part No. 93-5932)

⚠ WARNING

ON FAN SHROUD
(Part No. 77-3100)

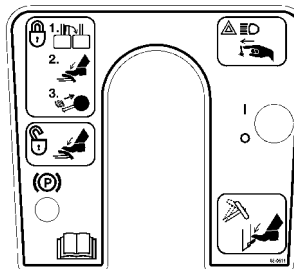

On Steering Tower
(Part No. 95-0814)

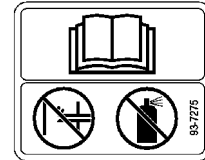

On Radiator Near Inlet
(Part No. 93-7275)

HYDRAULIC OIL ONLY

USE MOBIL 424

On Frame Above Front Axle
(Part No. 85-4730)

TRACTION PEDAL

FORWARD

REVERSE

NO STEP
USE OTHER SIDE

⚠ CAUTION

TURN OFF PTO. BEFORE RAISING IMPLEMENT TO TRANSPORT POSITION. DO NOT OPERATE IMPLEMENT IN TRANSPORT POSITION.

On Frame Next to Traction Pedal
(Part No. 92-5772)

SPECIFICATIONS

Engine: Peugeot TUD5, 4 cylinder, 4 cycle, in-line, over-head cam, liquid cooled diesel engine with centrifugal water pump. Available power, 36 hp at 2625 RPM. 1.5 liter displacement, governed to a maximum speed of 2780 RPM. Compression ratio 23.5:1. Glow plugs controlled by pre/post heat relay. Oil capacity 4.75 quart (4.5 liters) with oil filter. 12 volt type 4 starter motor with integral solenoid. 70 amp type 7 alternator with integral regulator.

Fuel Tank Capacity: 12 gallons diesel fuel

Radiator : Rear mount industrial radiator with tube and fin construction: 4 rows, 5 fins per inch. Thermally stable water cooled hydrostatic system regulates operating temperature. Separate degassing bottle to remove air from cooling system fluid. System capacity approximately 11.5 quarts (10.9 liter).

Controls: Hand operated throttle, PTO switch, hydraulic lift/lower/counterbalance of implement, ground speed high/low range switch, ignition switch. Foot operated tilt steering locking lever, traction pedal, steering/parking brake pedals.

Gauges and Diagnostics: Gauge package includes fuel gauge, engine coolant temperature gauge, and hour meter. Indicator light for high engine coolant temperature, low engine oil pressure, alternator, low engine coolant level, water in fuel, glow plugs.

Electrical Features: 12 volt automotive type electrical system. 650 cold cranking amp battery performance at 0°F. Dash mounted ignition switch. 70 amp alternator. PTO, seat and traction interlock switches.

Transaxle/PTO: Sauer-Sundstrand integrated hydrostatic transaxle (IHT-M15) incorporating the hydrostatic transmission, mechanical gearbox, differential, drive axle, power-take-off (PTO) system, implement hydraulic system pump and reservoir in a single component. Variable speed, axial piston, hydrostatic U-type transmission: gear type charge circuit hydraulics with filtration provides hydraulic flow for power steering and implement lift. Approximately 12 quart oil capacity. Single foot pedal control of forward/reverse ground speed. Two speed axle with "shift on the fly" speed range selection. 4wd is mechanically driven from front axle by a universal shaft. Double overrunning clutch provides 4wd function in forward and reverse preventing rear tire scuffing in turns. Both 2wd and 4wd have the same turning radius. Optional cruise control available.

Implement Lift: Twin hydraulic lift cylinders (2.5" bore x 3.5" stroke) provide lift, lower and counterbalance of implement via electrically actuated hydraulic control manifold.

Steering: Eaton Series 2 steering control unit with power beyond. Steering valve controls single steering cylinder. Steering system is single tie-rod type which provides identical steering performance on both two and four wheel drive versions. Tilt steering wheel with single lever control. 14" diameter steering wheel.

Ground Speed

Low speed – 0–8 mph, infinitely variable

High speed – 0–15 mph, infinitely variable

Clearance

Front ground clearance – 8.25 inches

Rear ground clearance – 2wd : 6.00 inches
4wd : 4.75 inches

Tires/Wheels/Pressures

Two front traction drive tires

Models 30301 TC and 30302 TC – 25 x10.5–15 turf tread, 6 ply rating.

Models 30301 and 30302 – 24 x13–12 turf tread, 4 ply rating.

Two rear steering tires

Models 30301 TC and 30302 TC – 20 x 8–10, turf tread, 6 ply rating.

Models 30301 and 30302 – 18 x 8.50–10, turf tread, 4 ply rating.

Tire pressure – 15 psi

Brakes: Individual mechanical caliper disc brakes provide both independent application for steering assist and combined application for parking brake function. Dynamic braking through the hydrostatic traction drive.

Seat: Deluxe high back seat. Optional seat suspension kit, Model 30395, or deluxe adjustable suspension kit, Model 30396.

Storage: Toolbox with cover located to the left of the seat base. Beverage holder integral to toolbox cover. Operator manual storage tube furnished for attachment to seat frame.

Weight: 2wd – 1930lbs (875kg)
4wd – 2030lbs (920kg)

Wheel Base: 55 inches

Tread Width: 53 inches

Specifications and design subject to change without notice.

LOOSE PARTS CHART

Note: Use this chart as a checklist to assure all parts necessary for assembly have been received. Without these parts, total set-up cannot be completed. Some parts may have already been assembled at factory.

DESCRIPTION	QTY.	USE
Wheel nut Wheel	10 2	Mount Rear Wheels
Wheel nut Wheel	10 2	Mount Front Wheels
Steering Wheel Foam Seal Nut Washer Cap	1 1 1 1 1	Install Steering Wheel
Seat Belt Bolt Lockwasher	1 2 2	Install Seat Belts to Seat. (Model 30302 only)
Roll Bar (ROPS) Bar Assembly Bolt Flat washer	1 2 8 8	Install Roll Bar. (Model 30302 only)
Operator's Manual Parts Catalog	2 1	
Registration Card	1	Fill out and return to Toro
Hydraulic Oil Filter (94-3951)	1	Change after 200 hours

SET-UP INSTRUCTIONS

INSTALL FRONT & REAR WHEELS

1. Mount wheels and torque mounting nuts to 80 ft-lbs (61-75 N·m).

INSTALLING STEERING WHEEL (Fig. 1)

1. Move rear wheels so they point straight ahead.
2. Slide steering wheel assembly onto steering shaft.

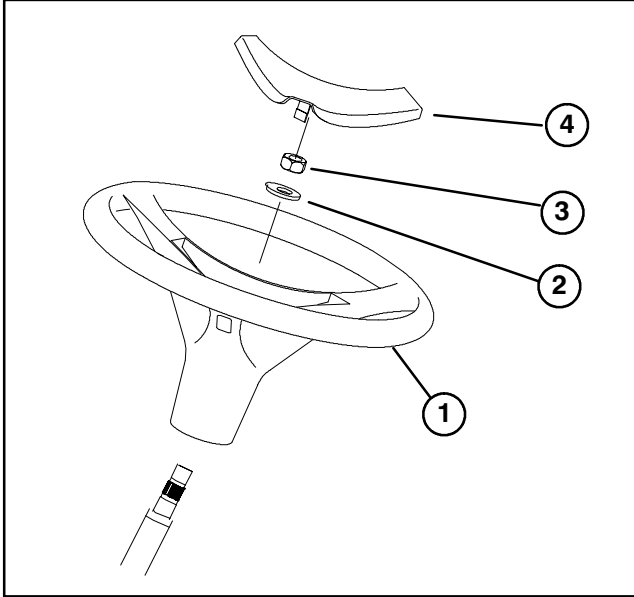

Figure 1

1. Steering Wheel
2. Flat Washer
3. Nut
4. Cap

3. Secure steering wheel to shaft with flat washer and nut. Tighten nut it to 10–15 ft-lb.
4. Install cap on steering wheel.

INSTALL ROLL BAR (Fig. 2) Model 30302 only

1. Loosely mount a bar assembly to each end of roll bar with (2) bolts and flatwashers.
2. Lower roll bar into frame holder, aligning mounting holes as shown in Fig. 2.

3. Loosely secure bar assembly to frame holder with (4) bolts and flat washers (Fig. 2).
4. Tighten all fasteners to 100 ft-lb..

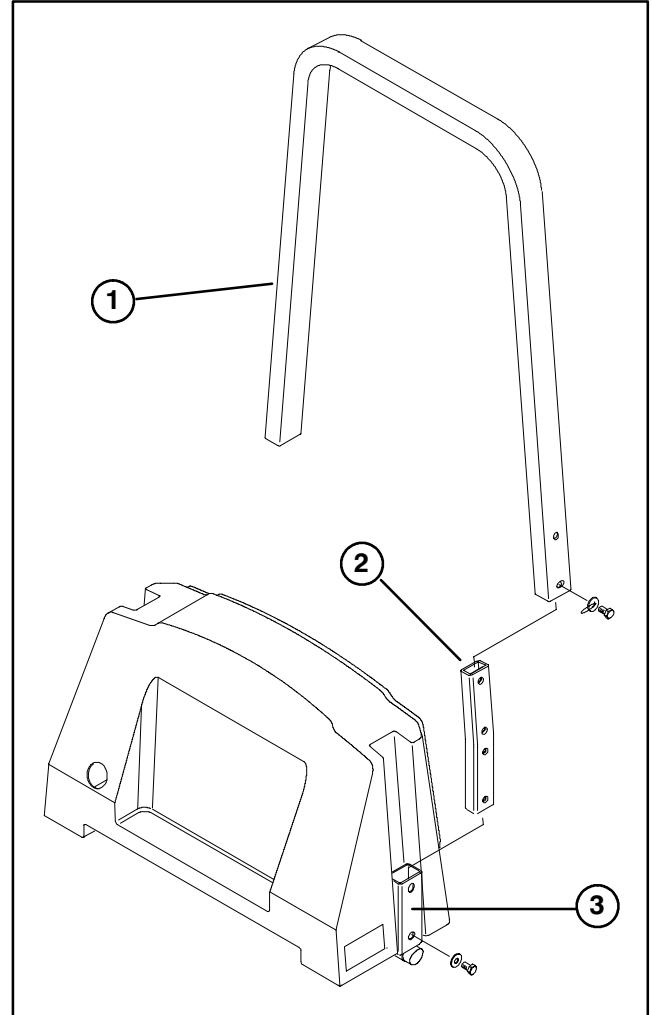

Figure 2

1. Roll Bar
2. Bar Assembly
3. Frame Holder

GREASE TRACTION UNIT

Before the machine is operated, it must be greased to assure proper operating characteristics; refer to Lubrication Maintenance. Failure to grease the machine will result in premature failure of critical parts.

BEFORE OPERATING



CAUTION

Before servicing or making adjustments to the machine, stop engine and remove key from the switch.

CHECK ENGINE OIL (Fig. 3 & 4)

Crankcase capacity is 4–3/4 qt. (4.5 l) with filter.

1. Park machine on a level surface. Rotate hood latch fully counterclockwise and open hood.

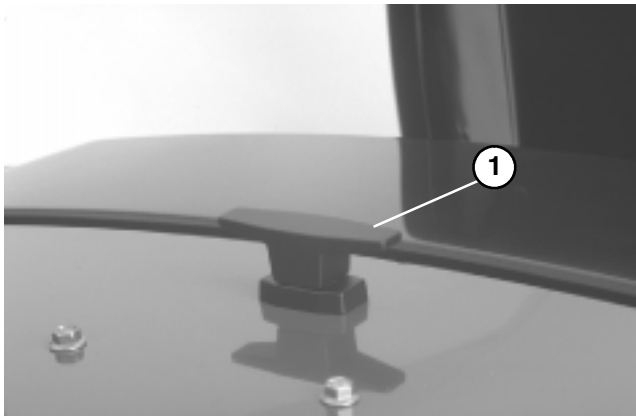

Figure 3
1. Hood Latch

2. Remove dipstick and wipe it with a clean rag. Insert dipstick into tube and make sure it is fully seated. Remove dipstick and check level of oil. If level of oil is low, add enough oil to raise level to notch in dipstick. **DO NOT OVERFILL.**

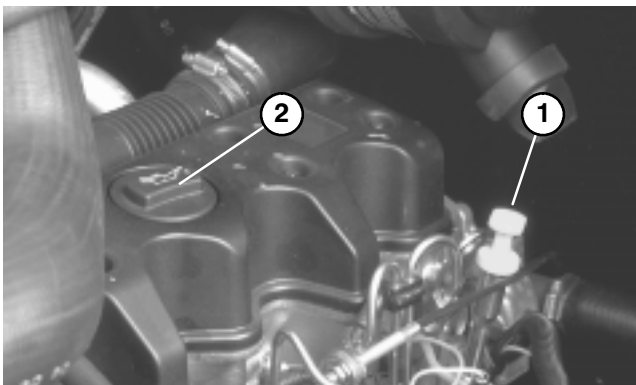

Figure 4
1. Dipstick
2. Oil Fill Cap

3. If oil level is low, clean area around oil fill cap, remove cap and add SAE 15W–40 CE oil until level reaches FULL mark on dipstick. **DO NOT OVERFILL.**
4. Install oil fill cap.
5. Close hood and secure latch.

CHECK COOLING SYSTEM (Fig. 5)

Capacity of system is 11.5 qts. (10.9 l).

Check cooling system if low water level light illuminates.

1. Park machine on a level surface. Release hood latch and open hood.
2. Remove degasser tank cap and check coolant level. **Coolant level should be up to or above tabs in degasser tank, when engine is cold.**



CAUTION

If engine has been running, pressurized hot coolant can escape and cause burns if degasser cap is removed. Allow engine to cool at least 15 minutes or until the degasser cap is cool enough to touch without burning hand.

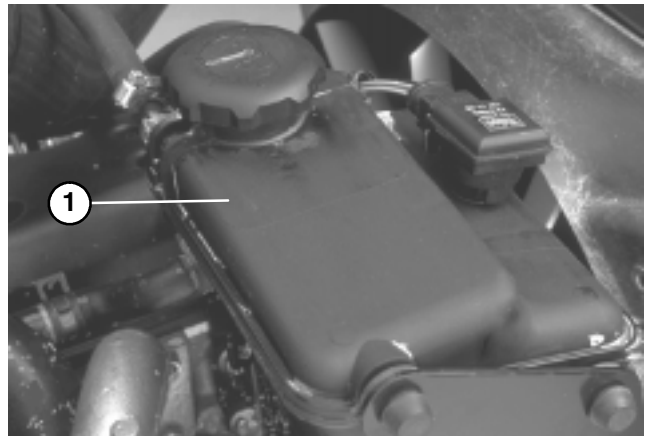

Figure 5
1. Degasser Tank

3. If coolant is low, remove degasser tank cap and add a 50/50 mixture of water and Peugeot recommended anti-freeze (Toro Part No. 93–7213). **DO NOT USE WATER ONLY OR ALCOHOL/METHANOL BASE COOLANTS.**
4. Install degasser tank cap.
5. Close hood and secure latch.

FILL FUEL TANK (Fig. 6)

Capacity of fuel tank is 12 gal.

1. Remove fuel tank cap.
2. Fill tank to about one inch below top of tank, not filler neck with No. 2 diesel fuel. Then install cap.

BEFORE OPERATING

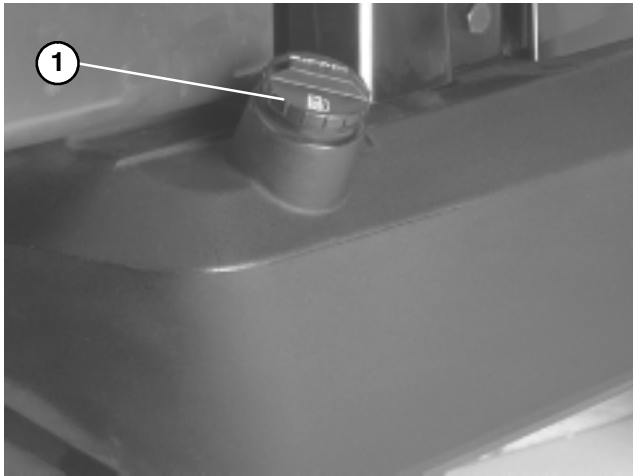

Figure 6
1. Fuel Tank Cap

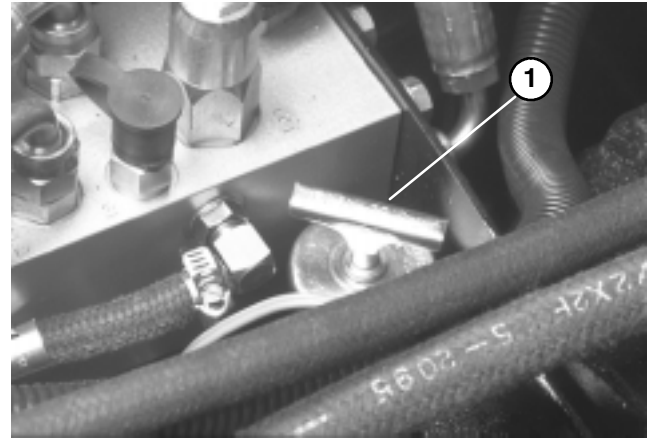

Figure 7
1. Dipstick cap



DANGER

Because diesel fuel is flammable, use caution when storing or handling it. Do not smoke while filling the fuel tank. Do not fill fuel tank while engine is running, hot, or when machine is in an enclosed area. Always fill fuel tank outside and wipe up any spilled diesel fuel before starting the engine. Store fuel in a clean, safety-approved container and keep cap in place. Use diesel fuel for the engine only; not for any other purpose.

CHECK HYDRAULIC FLUID (Fig. 7)

The hydraulic system is designed to operate on anti-wear hydraulic fluid. The machine's reservoir is filled at the factory with approximately 12 quarts of Mobil 424 hydraulic fluid. **Check level of hydraulic fluid before engine is first started and daily thereafter.**

1. Position machine on a level surface, raise the implement, and stop the engine.
2. Unscrew dipstick cap (Fig. 7) from the filler neck and wipe it with a clean rag. Screw dipstick cap finger tight onto filler neck. Unscrew the dipstick and check level of oil. If level is not up to FULL mark on dipstick (Fig. 7), add enough oil to raise level to mark. **DO NOT OVERFILL.**
3. Screw dipstick filler cap finger-tight onto filler neck.
4. Lower the implement.

The following fluids are recommended for use:

ISO type 46/68 anti-wear hydraulic fluid

Mobil	Mobil Fluid 424
Amoco	Amoco 1000
International Harvester	Hy-Tran
Texaco	TDH
Shell	Donax TD
Union Oil	Hydraulic/Tractor Fluid
Chevron	Tractor Hydraulic Fluid
BP Oil	BP HYD TF
Boron Oil	Eldoran UTH
Exxon	Torque Fluid
Conoco	Power-Tran 3
Kendall	Hyken 052
Phillips	HG Fluid

Note: The fluids within this group are interchangeable.

IMPORTANT: Do Not Use Biodegradable Hydraulic Fluid.

IMPORTANT: Use only types of hydraulic fluids specified. Other fluids could cause system damage.

Note: A red dye additive for detecting leaks in the hydraulic system is available in 2/3 oz. bottles. One bottle is sufficient for 4–6 gal. of hydraulic fluid. Order Part No. 44–2500 from your Authorized Toro Distributor

CHECK REAR AXLE LUBRICANT (Fig. 8) (Model 30302 Only)

The rear axle reservoir uses Mobil 424 hydraulic fluid. Although the axle is shipped with lubricant from the factory, check the level before operating the machine.

1. Position the machine on a level surface.
2. Remove check plug from axle and make sure lubricant is up to bottom of hole. If level is low, add enough lubricant to bring the level up to the bottom of the check hole (Fig. 8).

BEFORE OPERATING

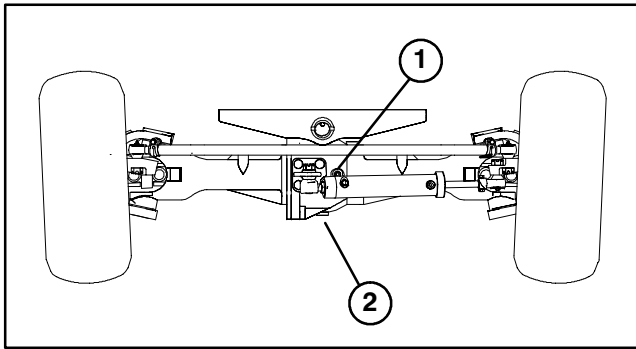

Figure 8

1. Check Plug
2. Drain Plug

CHECK TIRE PRESSURE (Fig. 9)

The tires are over-inflated for shipping. Therefore, release some of the air to reduce the pressure. Correct air pressure in the front and rear tires is 15 psi.

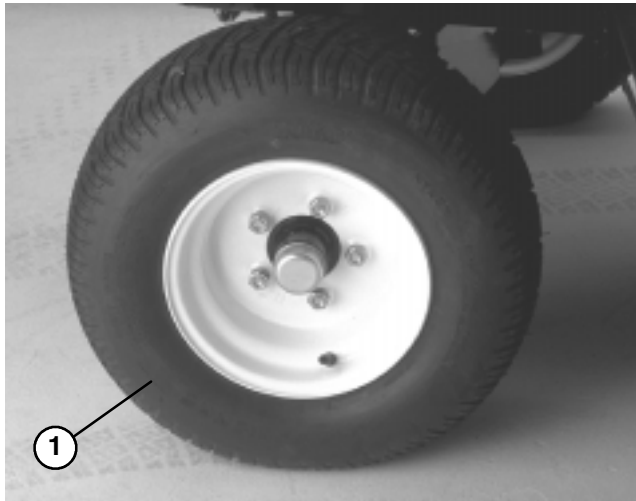

Figure 9

1. Rear Tire

IMPORTANT: Maintain even pressure in all tires to assure a good quality-of-cut and proper machine performance. **DO NOT UNDER INFLATE.**

CHECK TORQUE OF WHEEL NUTS



WARNING

Torque wheel nuts to 80 ft-lb after 1-4 hours of operation and again after 10 hours of operation and every 200 hours thereafter. Failure to maintain proper torque could result in failure or loss of wheel and may result in personal injury.

KNOW YOUR CONTROLS

Traction Pedal (Fig. 10) – Controls forward and reverse operation. Depress top of pedal to move forward and bottom to move backward. Ground speed depends on how far pedal is depressed. For no load, maximum ground speed, fully depress pedal while throttle is in FAST.

To stop, reduce foot pressure on traction pedal and allow it to return to center position.

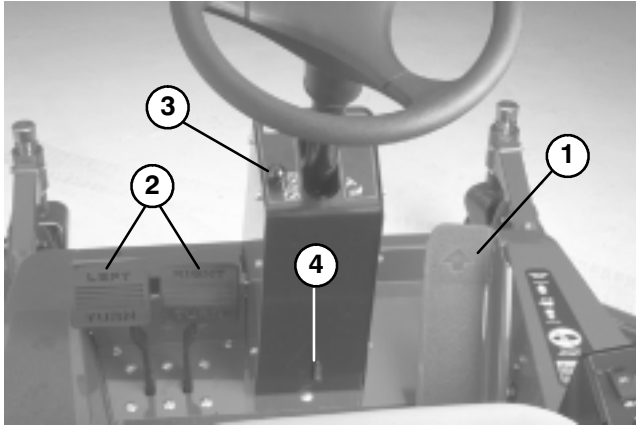

Figure 10

1. Traction Pedal
2. Brake Pedals
3. Parking Brake Latch
4. Tilt Steering Control

Brake Pedals (Fig. 10) – Two foot pedals operate individual wheel brakes for turning assistance, parking and to aid in obtaining better sidehill traction. Locking strap connects the pedals for parking brake operation.

Parking Brake Latch (Fig. 10) – A knob on the left side of console actuates parking brake lock. To engage parking brake, connect pedals with locking strap, push down on both pedals and pull parking brake latch out. To release parking brake, depress both pedals until parking brake latch retracts.

Tilt Steering Control (Fig. 10) – Lever on rear of steering tower. Push lever downward to adjust steering wheel to desired fore or aft operating position and release lever to lock adjustment.

Lift Lever (Fig. 11) – The lever raises and lowers the cutting unit.

PTO Switch (Fig. 11) – The PTO switch has three positions: ON (engage), Neutral and OFF (disengage). Slowly lift and push PTO switch forward to ON position to start the implement or cutting unit blades. Slowly pull switch backward to OFF position to stop implement operation. The only time PTO switch should be in the ON position is when implement or cutting unit is down in operating position.

Ignition Switch (Fig. 11) – Three positions: OFF, ON / Preheat and START.

Charge Indicator (Fig. 11) – Illuminates when system charging circuit malfunctions.

Low Water Level Light (Fig. 11) – Indicates coolant water level is low.

Engine Coolant Temperature Warning Light (Fig. 11) – The light illuminates and engine shuts down when coolant reaches a dangerously high temperature.

Engine Oil Pressure Warning Light (Fig. 11) – Indicates dangerously low engine oil pressure.

Glow Plug Indicator Light (Fig. 11) – When lit, indicates glow plugs are on.

Water in Fuel Light (Fig. 11) – Indicates water in fuel system.

Temperature Gauge (Fig. 11) – The temperature gauge registers the temperature of the coolant in the cooling system.

Temperature Reset Button (Fig. 11) – Press and hold reset button to start engine after high temperature shut down.

Hour Meter (Fig. 11) – Shows total hours that machine has been operated.

Fuel Gauge (Fig. 11) – Indicates level of fuel in tank.

Throttle Control (Fig. 11) – Move control forward to increase engine speed, rearward to decrease speed.

Hi-Lo Speed Control (Fig. 11) – Allows speed range to increase for transport of machine.

Cruise Control (Optional) (Fig. 11) – Controls speed of machine.

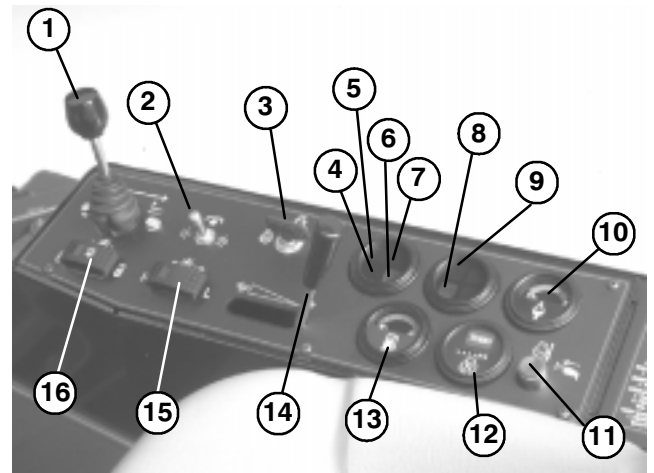

Figure 11

- | | |
|---|-------------------------------|
| 1. Lift Lever | 8. Glow Plug Indicator Light |
| 2. PTO Switch | 9. Water in Fuel Light |
| 3. Ignition Switch | 10. Temperature Gauge |
| 4. Charge Indicator | 11. Temperature Reset Button |
| 5. Low Water Level Light | 12. Hour Meter |
| 6. Engine Coolant Temperature Warning Light | 13. Fuel Gauge |
| 7. Engine Oil Pressure Warning Light | 14. Throttle Control |
| | 15. Hi-Lo Speed Control |
| | 16. Cruise Control (Optional) |

OPERATING INSTRUCTIONS



CAUTION

Before servicing or making adjustments to the machine, stop engine and remove key from the switch.

STARTING/STOPPING ENGINE

IMPORTANT: The fuel system must be bled if any of the following situations have occurred:

- A. Initial start up of a new machine.
 - B. Engine has ceased running due to lack of fuel.
 - C. Maintenance has been performed upon fuel system components.
 - D. Refer to Priming Fuel System.
1. Ensure parking brake is set. Remove foot from traction pedal and insure it is in neutral.
 2. Move throttle control to low idle position.
 3. Turn ignition key to RUN position, glow indicator will light.

Note: Do not run starter motor more than 15 seconds at a time or premature starter failure may result. If engine fails to start after 15 seconds, turn key to OFF position, recheck controls and procedures, wait 15 additional seconds and repeat starter procedure.

4. When glow indicator dims, turn ignition key to START position. Release key immediately when engine starts and allow it to return to RUN position. Move throttle control to desired position.
5. When engine is started for the first time, or after overhaul of the engine, transmission or axle, operate the machine in forward and reverse for one or two minutes. Also operate the lift lever and PTO lever to assure proper operation of all parts. Turn steering wheel to the left and right to check steering response. Then shut engine off and check for oil leaks, loose parts, and any other noticeable difficulties.



CAUTION

Shut engine off and wait for all moving parts to stop before checking for oil leaks, loose parts, or other difficulties.

6. To stop engine, move throttle control backward to SLOW position, move PTO lever to OFF position, and rotate ignition key to OFF. Remove key from switch to prevent accidental starting.

PRIMING FUEL SYSTEM (Fig. 12)

IMPORTANT: The fuel system may need to be primed when a new engine is started for the first time, if it runs out of fuel or if maintenance is performed on the fuel system.

1. Unlatch and raise hood.
2. Insert a 3/16" hose over bleed screw and run other end into a container to catch fuel.
3. Loosen fuel filter / water separator bleed screw (Fig. 12) a few turns. Pump priming plunger until a steady stream of fuel comes out of hole in bleed screw. When fuel stops foaming, tighten the bleed screw during the downstroke of the priming plunger. Wipe up any spilled fuel.

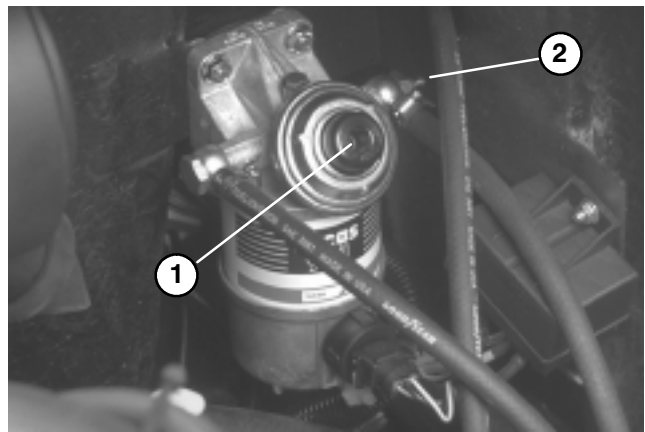

Figure 12

1. Primer Plunger 2. Bleed Screw

4. Pump priming plunger until resistance is felt. Try to start engine. If engine does not start repeat step 3.

CHECKING INTERLOCK SWITCHES

The machine has interlock switches in the electrical system. These switches are designed to stop the engine when operator gets off the seat when traction pedal is depressed. However, operator may get off the seat while engine is running. Although engine will continue to run if PTO lever is disengaged and traction pedal is released, it is strongly recommended that the engine be stopped before dismounting from the seat.



CAUTION

Do not disconnect the interlock switches. Check operation of switches daily to assure interlock system is operating correctly. If a switch is malfunctioning, replace it before operating the machine. To ensure maximum safety, replace all switches after every two years or 1000 hours, whichever comes first.

OPERATING INSTRUCTIONS

To check operation of interlock switches:

1. Drive the machine slowly to a large, relatively open area. Lower cutting unit, stop the engine and apply parking brake.
2. Sit on seat. Depress the traction pedal. Try to start the engine. The engine should not crank. If the engine cranks, there is a malfunction in the interlock system that should be corrected before beginning operation.



3. Sit on seat and start the engine. Raise off the seat and move the PTO lever to ON. The PTO should not engage. If the PTO engages, there is a malfunction in the interlock system that should be corrected before beginning operation.

PUSHING OR TOWING TRACTION UNIT (Fig. 13)

In an emergency, the traction unit can be pushed or towed. However, Toro does not recommend this as standard procedure.

IMPORTANT: Do no push or tow the traction unit faster than 10 mph. If traction unit must be moved a considerable distance, transport it on a truck or trailer.

1. Locate towing lever on right side of axle assembly.
2. Remove cotter pin and clevis pin securing lever to plate on side of axle.

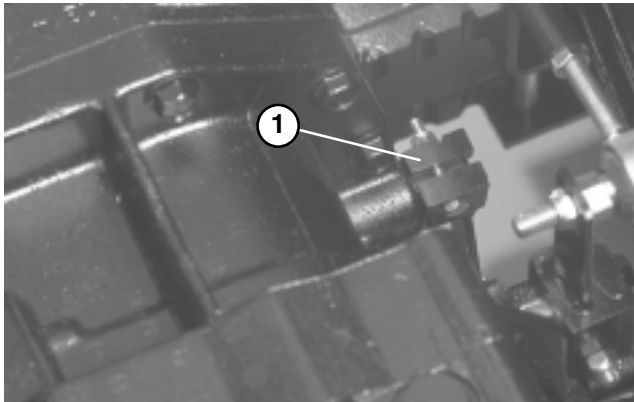

Figure 13
1. Towing Lever

3. Pivot lever rearward until hole is aligned with rear hole in plate. Secure lever to rear hole with cotter pin and clevis pin previously removed.

4. After completion of towing operation, pivot lever back to original position and re-secure.

OPERATING CHARACTERISTICS

Practice driving the GROUNDSMASTER 3000-D because it has a hydrostatic transmission and its characteristics are different than many turf maintenance machines. Some points to consider when operating the traction unit, cutting unit, or other implement are the transmission, engine speed, load on the cutting blades or other implement components, and the importance of the brakes.

To maintain enough power for the traction unit and implement while operating, regulate traction pedal to keep engine rpm high and somewhat constant. A good rule to follow is: decrease ground speed as the load on the implement increases, and increase ground speed as the load decreases.

Therefore, allow traction pedal to move backward as engine rpm decrease, and depress pedal slowly as rpm increase. By comparison, when driving from one work area to another—with no load and cutting unit raised—have throttle in FAST position and depress traction pedal slowly but fully to attain maximum ground speed.

Another characteristic to consider is the operation of the pedals that are connected to the brakes. The brakes can be used to assist in turning the machine. However, use them carefully, especially on soft or wet grass because the turf may be torn accidentally. Another benefit of the brakes is to maintain traction. For example: in some slope conditions, the uphill wheel slips and loses traction. If this situation occurs, depress uphill turn pedal gradually and intermittently until the uphill wheel stops slipping, thus, increasing traction on the downhill wheel.

Use extra care when operating machine on slopes. Make sure seat latch is properly secured. Drive slowly and avoid sharp turns on slopes to prevent roll overs. The cutting deck must be lowered when going downhill for steering control.

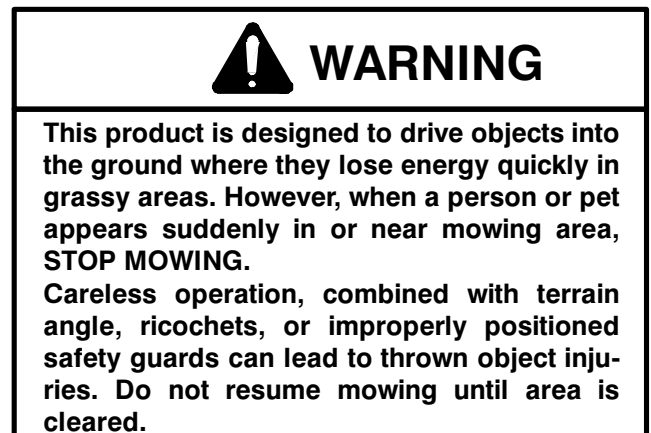

OPERATING INSTRUCTIONS

Before stopping the engine, disengage all controls and move throttle to SLOW. Moving throttle to SLOW reduces high engine rpm, noise, and vibration. Turn key to OFF to stop engine.

Before transporting machine, raise cutting deck and secure with transport latch.

CAUTION: This product may exceed noise levels of 85 dB(A) at the operator position. Ear protectors are recommended, for prolonged exposure, to reduce the potential of permanent hearing damage.

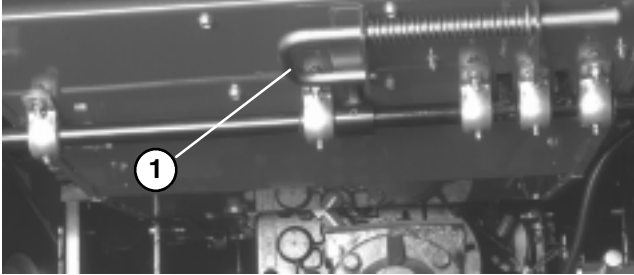

Figure 14
1. Transport Latch

LUBRICATION



CAUTION

Before servicing or making adjustments to the machine, stop engine and remove key from the switch.

GREASING BEARINGS AND BUSHINGS

(Fig. 15–20)

The machine has grease fittings that must be lubricated regularly with No. 2 General Purpose Lithium Base Grease. If machine is operated under normal conditions, lubricate all bearings and bushings after every 50 hours of operation or immediately after every washing.

The grease fitting locations and quantities are:

2 Wheel Drive Models only—Steering cylinder ball joint, Rear axle tie rod (2), Rear axle pivot (1) Rear Spindle Shafts (2) (Fig. 15).

4 Wheel Drive Models only—Steering cylinder ball joints, Rear axle tie rod (2), Rear axle pivot (1), Double Cardan joints (2 ea. side) (Fig. 16) and Rear Drive Shaft (3) (Fig. 17).

All Models—Intermediate Drive Shaft (9) (Fig. 18); Pedal Pivots (5), Traction pedal (In square tube under floor plate) (1) (Fig. 19) and Lift arm pivot (2) (Fig. 20).

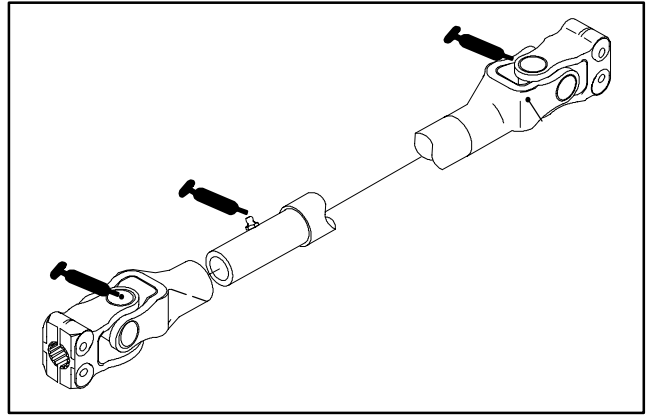

Figure 17

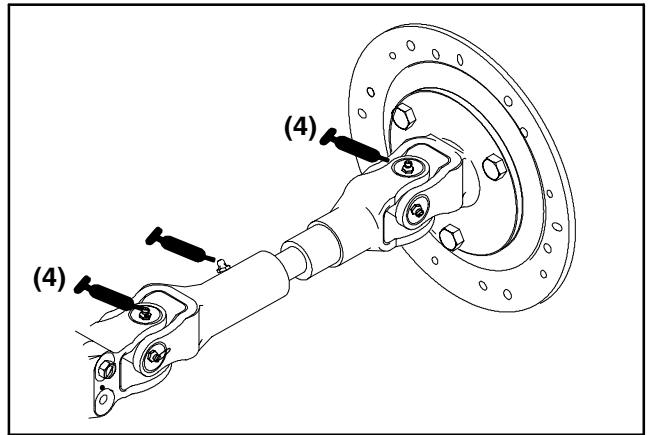

Figure 18

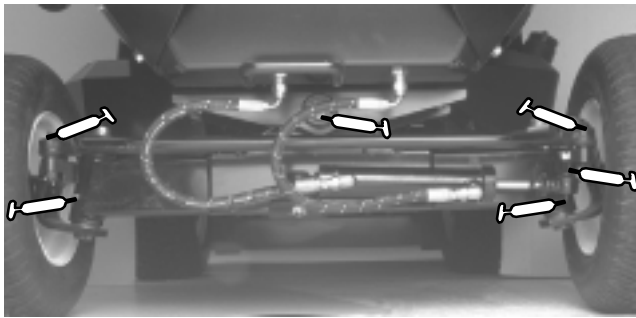

Figure 15

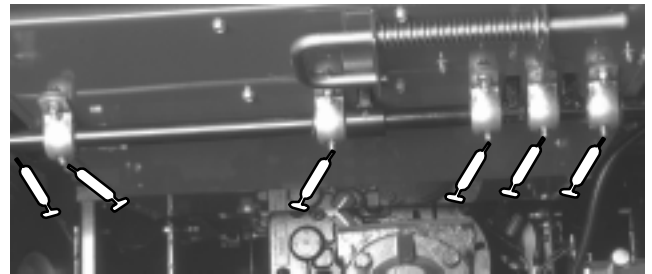

Figure 19

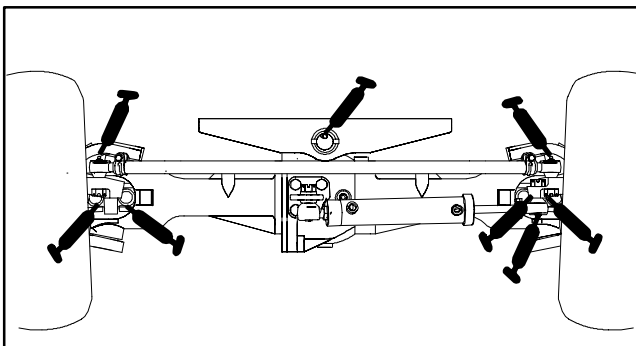

Figure 16



Figure 20

DAILY MAINTENANCE CHECKLIST

Daily Maintenance: (duplicate this page for routine use)

Check proper section of Operator's Manual for fluid specifications

Maintenance Check Item ▼	Daily Maintenance Check For Week Of _____						
	MON	TUES	WED	THURS	FRI	SAT	SUN
✓ Safety Interlock Operation							
✓ Brake Operation							
✓ Engine Oil & Fuel Level							
✓ Cooling System Fluid Level							
Drain Water/Fuel Separator							
✓ Radiator & Screen for Debris							
✓ Unusual Engine Noises ¹							
✓ Unusual Operating Noises							
✓ Hydraulic System Oil Level							
✓ Hydraulic Hoses for Damage							
✓ Fluid Leaks							
✓ Tire Pressure							
✓ Instrument Operation							
Lubricate All Grease Fittings ²							
Touch-up Damaged Paint							

¹ = Check glow plug and injector nozzles, if hard starting, excess smoke or rough running is noted.

² = Immediately after every washing, regardless of the interval listed.

Notation for areas of concern: Inspection performed by _____

Item	Date	Information
1		
2		
3		
4		
5		
6		
7		
8		

MAINTENANCE SCHEDULE

Minimum Recommended Maintenance Intervals

Maintenance Procedure	Maintenance Interval & Service				
<div style="border: 1px solid black; padding: 5px; margin-bottom: 10px;"> Lubricate All Grease Fittings Every 50hrs Inspect Air Filter Check Battery Level/Cable Connections </div> ‡ Change Engine Oil and Filter Inspect Cooling System Hoses † Check Fan and Alternator Belt Tension † Torque Wheel Lug Nuts Service Spark Arrester Muffler	Every 100hrs	Every 200hrs	Every 400hrs	Every 800hrs	
Service Air Filter Change Fuel Filter Inspect Fuel Lines and Connections ‡ Check Engine RPM (idle and full throttle) Check Rear Axle Oil Level (4wd) <input type="checkbox"/> Change Hydraulic Oil <input type="checkbox"/> Change Hydraulic Oil Filter <input type="checkbox"/> Change Rear Axle Oil Level (4wd)					
Inspect Engine Timing Belt (see note below) Drain and Clean Fuel Tank Pack 2WD Rear Axle Bearings Check Rear Wheel Toe-In					
† Initial break in at 10 hours ‡ Initial break in at 50 hours <input type="checkbox"/> Initial break in at 200 hours					
Replace Moving Hoses Replace Safety Switches Cooling System Flush/Replace Fluid	Annual Recommendations: Items listed are recommended every 1500 hours or 2 years, whichever occurs first.				

NOTE: Replace Timing Belt after every 2500 hours of operation or if worn, cracked, oil soaked or any time the Belt is removed or loosened.

AIR CLEANER MAINTENANCE



CAUTION

Before servicing or making adjustments to the machine, stop engine and remove key from the switch.

GENERAL AIR CLEANER MAINTENANCE

1. Inspect air cleaner after every 50 hours of operation. More frequent in dusty or dirty conditions.
2. Check air cleaner body for damage which could possibly cause an air leak. Replace a damaged air cleaner body.
3. Service the air cleaner filter every 400 hours (more frequently in extreme dusty or dirty conditions). Do not over service air filter.
4. Be sure cover is sealing around air cleaner body.



CAUTION

Never operate machine without complete air cleaner assembly in place and latched properly or a damaged air cleaner Debris entering engine can cause engine failure.

SERVICING AIR CLEANER (Fig. 21 & 22)

1. Release latches securing air cleaner cover to air cleaner body. Separate cover from body. Clean inside of air cleaner cover.

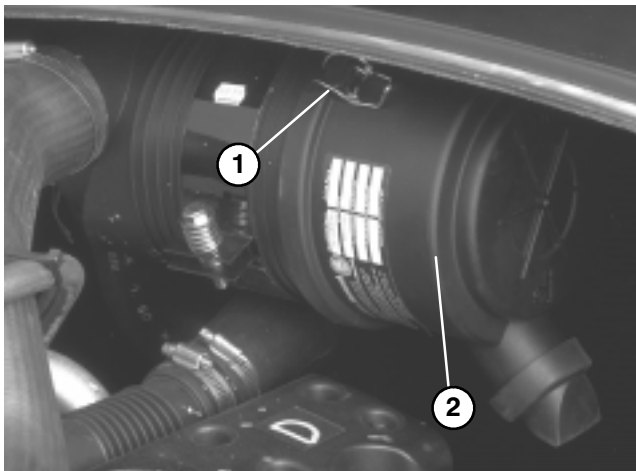

Figure 21

1. Air cleaner latches
2. Dust cup

2. Gently slide filter (Fig. 22) out of air cleaner body to reduce the amount of dust dislodged. Avoid knocking filter against air cleaner body.

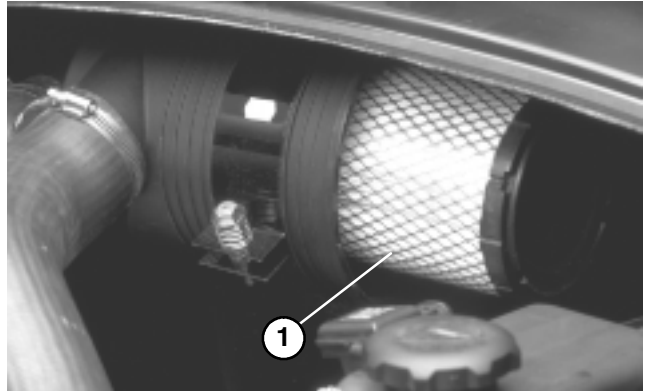

Figure 22

1. Air cleaner filter

3. Inspect filter and discard if damaged. Do not wash or reuse a damaged filter.

Washing Method

- A. Prepare a solution of filter cleaner and water and soak filter element about 15 minutes. Refer to directions on filter cleaner carton for complete information.
- B. After soaking filter for 15 minutes, rinse it with clear water. Maximum water pressure must not exceed 40 psi to prevent damage to the filter element. Rinse filter from clean side to dirty to side.
- C. Dry filter element using warm, flowing air (160°F) max), or allow element to air-dry. Do not use a light bulb to dry the filter element because damage could result.

Compressed Air Method

- A. Blow compressed air from inside to the outside of dry filter element. Do not exceed 100 psi to prevent damage to the element.
 - B. Keep air hose nozzle at least 2" from filter and move nozzle up and down while rotating the filter element. Inspect for holes and tears by looking through the filter toward a bright light.
5. Inspect new filter for shipping damage. Check sealing end of filter. Do not install a damaged filter.
 6. Insert new filter properly into air cleaner body. Make sure filter is sealed properly by applying pressure to outer rim of filter when installing. Do not press on flexible center of filter.
 7. Reinstall cover and secure latches. Make sure cover is positioned with TOP side up.

ENGINE MAINTENANCE



CAUTION

Before servicing or making adjustments to the machine, stop engine and remove key from the switch.

ENGINE OIL AND FILTER (Fig. 23–24)

Change oil and filter initially after the first 50 hours of operation, thereafter change oil and filter every 100 hours.

1. Remove drain plug (Fig. 23) and let oil flow into drain pan. When oil stops, install drain plug and new plug seal, Part No. 74–7850.

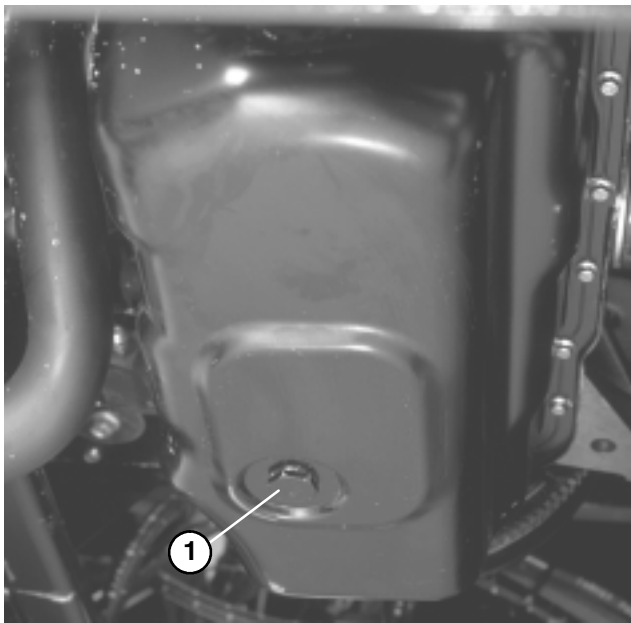

Figure 23
1. Drain Plug

2. Remove oil filter (Fig. 24). Apply a light coat of clean oil to the new filter seal before screwing it on. DO NOT OVER-TIGHTEN.

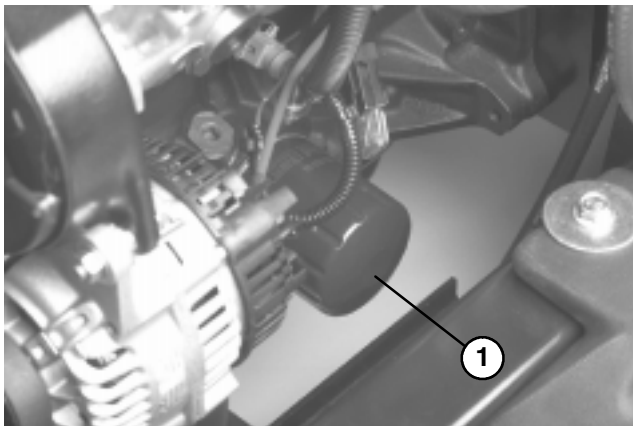

Figure 24
1. Oil Filter

3. Add 15W–40 CE oil to crankcase. Capacity is 4.75 quarts with filter.

FUEL SYSTEM (Fig. 25)

Fuel Tank

Drain and clean fuel tank every 800 hours of operation or yearly, whichever comes first. Also, drain and clean tank if fuel system becomes contaminated or if machine is to be stored for an extended period. Use clean fuel to flush out the tank.



DANGER

Because diesel fuel is highly flammable, use caution when storing or handling it. Do not smoke while filling the fuel tank. Do not fill fuel tank while engine is running, hot, or when machine is in an enclosed area. Always fill fuel tank outside and wipe up any spilled diesel fuel before starting the engine. Store fuel in a clean, safety-approved container and keep cap in place. Use diesel fuel for the engine only; not for any other purpose.

Fuel Lines and Connections

Check lines and connections every 400 hours or yearly, whichever comes first. Inspect for deterioration, damage, or loose connections.

Draining Fuel Filter / Water Separator

Drain water or other contaminants from fuel filter / water separator daily.

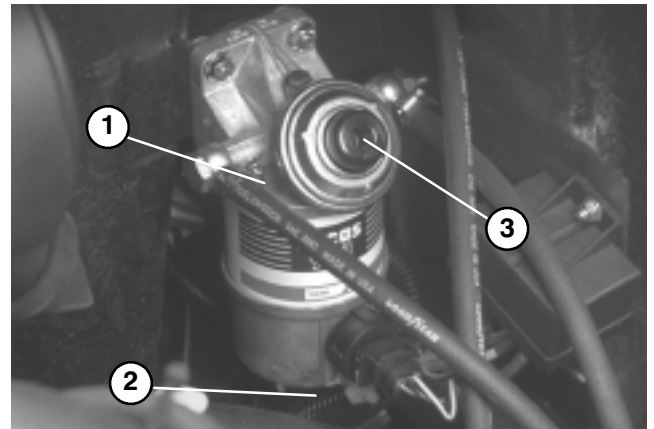

Figure 25

1. Fuel Filter
2. Drain Screw
3. Primer plunger

1. Place a clean container under fuel filter.
2. Loosen drain screw on bottom of fuel filter and press primer plunger until only fuel is evident draining into container.
3. Tighten drain screw.

ENGINE MAINTENANCE

Changing Fuel Filter

Replace fuel filter if fuel flow becomes restricted, after every 400 hours of operation or annually, whichever comes first.

1. Loosen bolt and unscrew bottom filter cap from filter assembly. Remove cap, gaskets, o-ring and filter from assembly. Note position of gaskets and o-ring when disassembling from filter.
3. Install new filter, gaskets, o-ring with filter assembly cap.
4. Prime fuel system, refer to Priming Fuel System.

ENGINE COOLING SYSTEM (Fig. 26–27)

1. Removing Debris – Remove debris from rear screen, oil cooler and radiator daily, clean more frequently in dirty conditions.

IMPORTANT: Never spray water onto a hot engine as damage to engine may occur.

- A. Turn engine off and clean hood screen thoroughly.

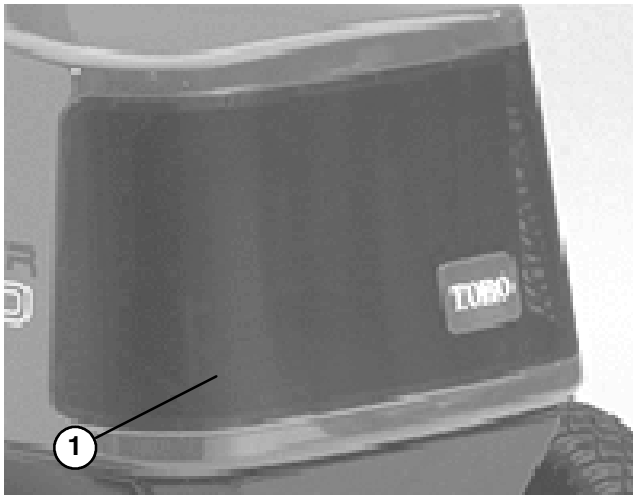

Figure 26
1. Rear Screen

- B. Release hood latch and raise hood. Clean engine area thoroughly of all debris.
- C. Clean both sides of oil cooler and radiator area thoroughly with compressed air. **Do not use water.**

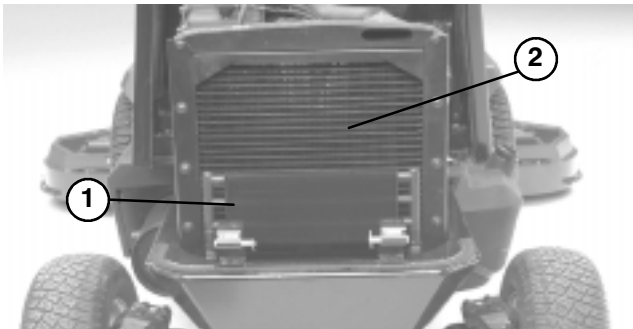

Figure 27
1. Oil Cooler
2. Radiator

- D. Close hood and secure latch.

Note: Do not use water to clean engine or electrical components, as damage may occur.

2. Maintaining Cooling System – Capacity of the system is 11.5 quarts. Always protect cooling system with a 50/50 solution of water and Peugeot recommended anti-freeze (Part No. 93–7213). **DO NOT USE WATER ONLY IN COOLING SYSTEM.**

- A. After every 100 operating hours, inspect and tighten hose connections. Replace any deteriorated hoses.
- B. After every 2 years, drain and flush the cooling system. Add anti-freeze (refer to Check Cooling System).

ENGINE BELTS (Fig. 28)

Check condition and tension of belts after every 100 hours of operation (Fig. 28). Replace belts as required.

Alternator Belt

1. Proper tension will allow 1/8 in. deflection on the belt midway between the pulleys, when pressed firmly with thumb.

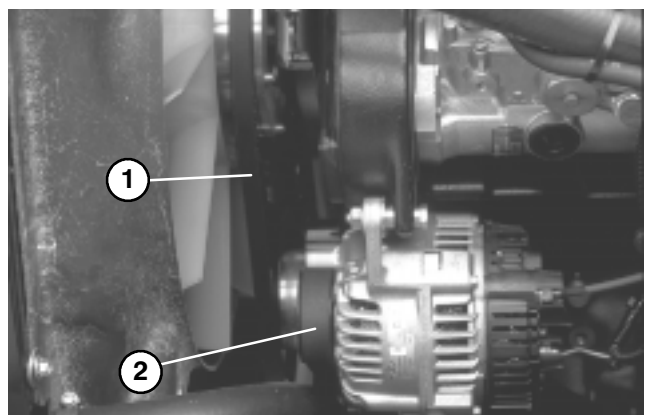

Figure 28
1. Fan Belt
2. Alternator belt

2. If deflection exceeds 1/8 in., loosen alternator mounting bolts. Adjust belt tension and tighten mounting bolts. Check deflection of belt again to assure tension is correct.

ENGINE MAINTENANCE

Fan Belt

1. Proper tension will allow 3/8 in. deflection on the belt midway between the pulleys, when pressed firmly with thumb.
2. If deflection exceeds 3/8 in., loosen pulley mounting bolt. Adjust belt tension and tighten mounting bolt. Check deflection of belt again to assure tension is correct.

SERVICING SPARK ARRESTOR MUFFLER

Every 200 hours operation, clear the muffler of carbon buildup.

1. Remove pipe plug from clean-out port at lower side of muffler.



CAUTION

Be careful while working around muffler as it may be hot and could cause injury.

2. Start engine. Plug the normal muffler exit with block of wood or metal plate so exhaust flow will be forced out of the clean-out port. Continue to block exit until carbon deposits cease coming out port.



CAUTION

Do not stand in line with the clean-out port. Always wear safety glasses.

3. Stop engine and replace pipe plug.

HYDRAULIC MAINTENANCE



CAUTION

Before servicing or making adjustments to the machine, stop engine and remove key from the switch.

CHANGING HYDRAULIC SYSTEM OIL & FILTER (Fig. 30 – 29)

The hydraulic system oil and filter must be changed initially at 200 hours and thereafter every 400 hours of operation or seasonally, whichever comes first. The hydraulic system is designed to operate on anti-wear hydraulic fluid. The machine's reservoir is filled at the factory with approximately 12 quarts of Mobil 424 hydraulic fluid. **Check level of hydraulic fluid before engine is first started and daily thereafter.**

The following fluids are recommended for use:

ISO type 46/68 anti-wear hydraulic fluid

Mobil	Mobil Fluid 424
Amoco	Amoco 1000
International Harvester	Hy-Tran
Texaco	TDH
Shell	Donax TD
Union Oil	Hydraulic/Tractor Fluid
Chevron	Tractor Hydraulic Fluid
BP Oil	BP HYD TF
Boron Oil	Eldoran UTH
Exxon	Torque Fluid
Conoco	Power-Tran 3
Kendall	Hyken 052
Phillips	HG Fluid

Note: The fluids within this group are interchangeable.

IMPORTANT: Do Not Use Biodegradable Hydraulic Fluid.

IMPORTANT: Use only types of hydraulic fluids specified. Other fluids could cause system damage.

1. Start engine, park machine on a level surface, lower implement to the shop floor, set the parking brake, and shut engine off.
2. Clean area around dipstick cap (Fig. 29) and remove cap from axle filler tube.
3. To ease access to axle housing drain plug (Fig. 30), implement may be removed from traction unit.
4. Remove drain plug from axle housing and allow oil to flow into drain pan.

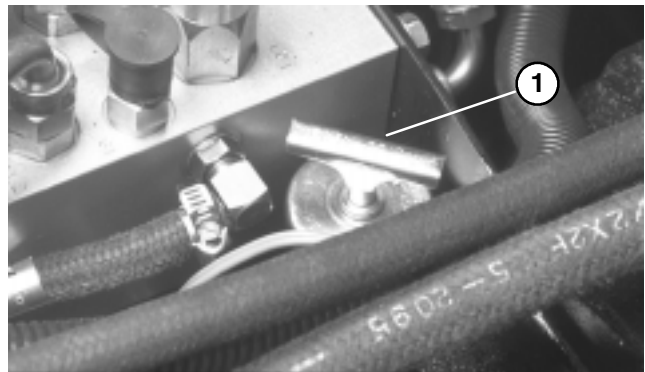

Figure 29
1. Dipstick cap

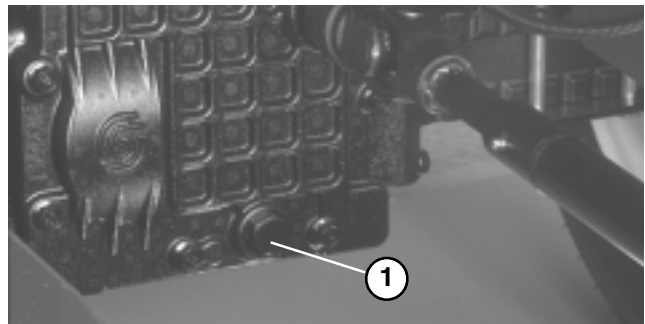

Figure 30
1. Drain plug

5. Clean area around hydraulic oil filter and remove filter (Fig. 31).



Figure 31
1. Hydraulic Filter

6. Lubricate new filter seal and install filter.
7. Install drain plug in axle housing (Fig. 30).
8. Through axle filler tube, fill axle to proper level with Mobil 424 hydraulic fluid. Install dipstick cap.
9. Start and run the engine at idle speed for about two minutes, raise and lower implement and turn the steering wheel lock to lock to purge air trapped in the system. Shut the engine off.
10. Let machine set for two additional minutes, then remove dipstick and check oil level in axle. If level is low, add oil until level matches groove in dipstick. If level is too high, remove drain plug and drain oil until oil level matches Full mark on dipstick.

HYDRAULIC MAINTENANCE

CHECKING HYDRAULIC LINES AND HOSES

Inspect hydraulic lines and hoses daily for leaks, kinked lines, loose mounting supports, wear, loose fittings, weather deterioration and chemical deterioration. Make all necessary repairs before operating.

**WARNING**

Keep body and hands away from pin hole leaks or nozzles that eject high pressure hydraulic fluid. Use cardboard or paper to find hydraulic leaks. Hydraulic fluid escaping under pressure can penetrate skin and cause injury. Fluid accidentally injected into the skin must be surgically removed within a few hours by a doctor familiar with this form of injury or gangrene may result.

HYDRAULIC SYSTEM TEST PORT (Fig. 32)

The test port is used to test pressure in the hydraulic circuits. Contact your local Toro distributor for assistance.

1. Test Port #1 (Fig. 32) is used to adjust pressure in counterbalance circuit.

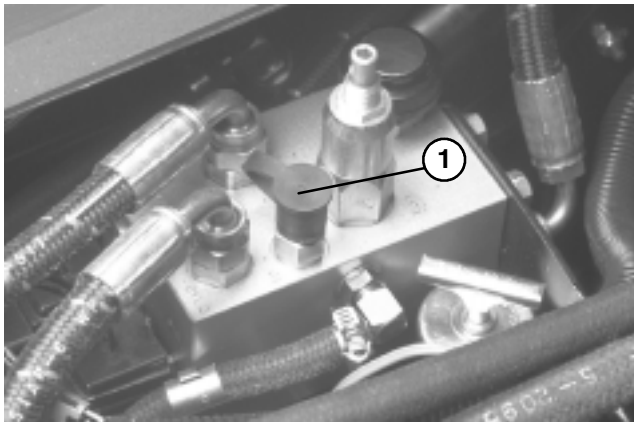

Figure 32
1. Test Port

ADJUSTING TRACTION PEDAL LINKAGE (Fig. 33 & 34)

Traction pedal to reach full stroke prior to contact with stop.

1. Park machine on a level surface, shut engine off and lower cutting unit to the floor.
2. Check pedal stop adjustment. Distance from top of stand to top of stop must be 1.25". Loosen jam nuts and adjust stop if required.

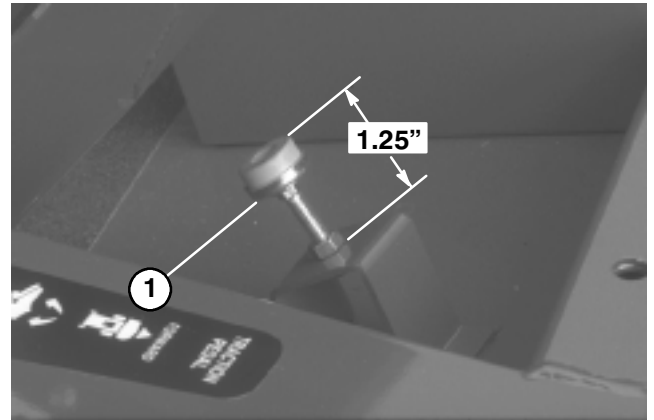

Figure 33

1. Traction Pedal Stop

3. Loosen jam nuts securing traction rod to transmission lever pivot capscrew.

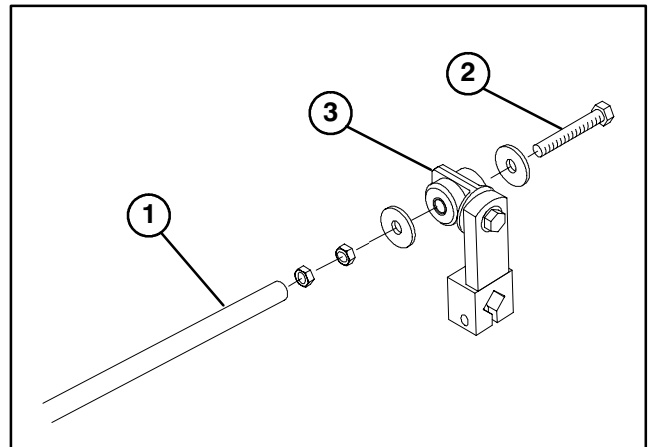

Figure 34

1. Traction Rod
2. Capscrew
3. Lever

4. Adjust capscrew until traction pedal reaches full forward stroke just before pedal contacts stop.
5. Tighten jam nuts to lock adjustment.

HYDRAULIC SCHEMATIC

LIFT/LOWER CONTROL SOLENOIDS
 S1 S2
 LIFT — ON OFF
 HOLD — OFF OFF
 LOWER/FLOAT — OFF ON

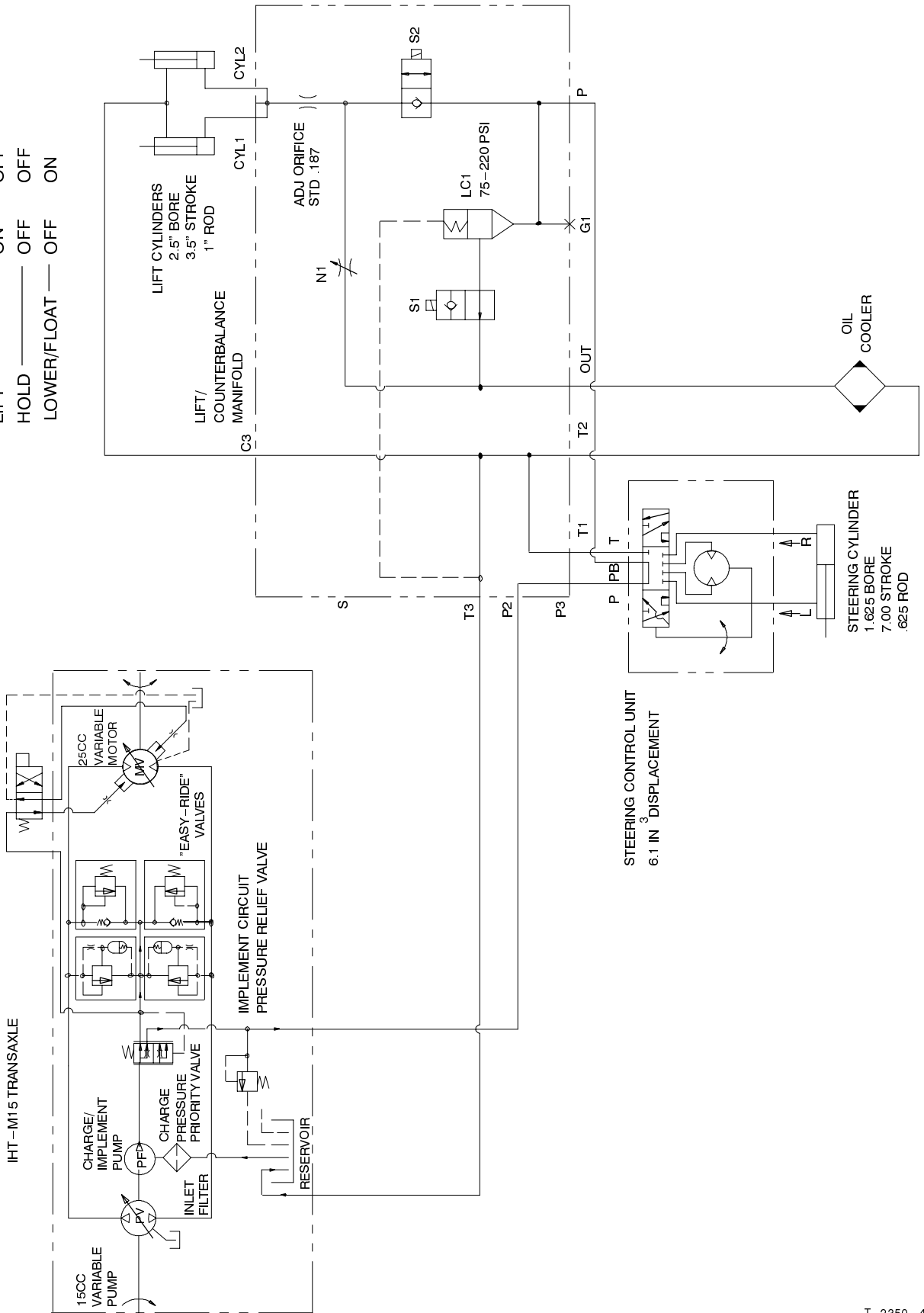

BRAKE MAINTENANCE

ADJUSTING SERVICE BRAKES (Fig. 35)

If excessive pedal travel is required to engage brake or as brake pads wear, an adjustment to the brake linkage may be required.

1. Jack up front of machine and support with jack stands.
2. Remove left front tire.
3. With brake linkage bellcrank against frame stop, loosen jam nut disconnect clevis from bellcrank and adjust linkage until there is a slight drag on rotor.
4. Back off clevis one full turn and reinstall to bellcrank.
5. Tighten jam nut.
6. Repeat procedure on opposite wheel.

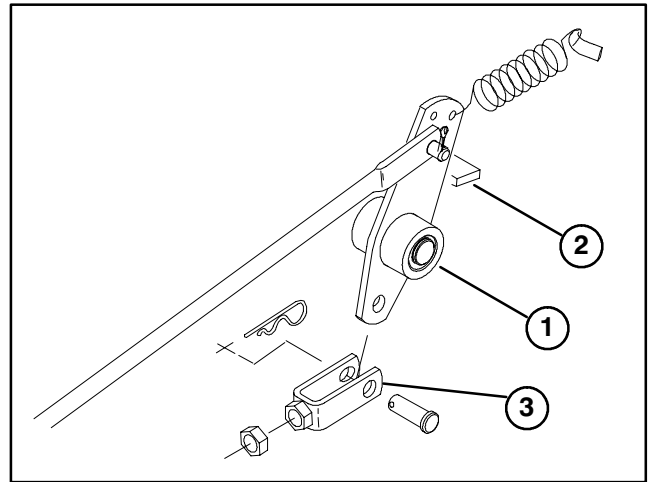

Figure 35

1. Bellcrank
2. Frame stop
3. Linkage Clevis

AXLE MAINTENANCE



CAUTION

Before servicing or making adjustments to the machine, stop engine and remove key from the switch.

CHANGING REAR AXLE LUBRICANT (Model 30302 only) (Fig. 36)

Initially, change oil in rear axle after 200 hours, thereafter change every 400 hours of operation.

1. Position machine on a level surface.
2. Clean area around drain plug on rear axle.

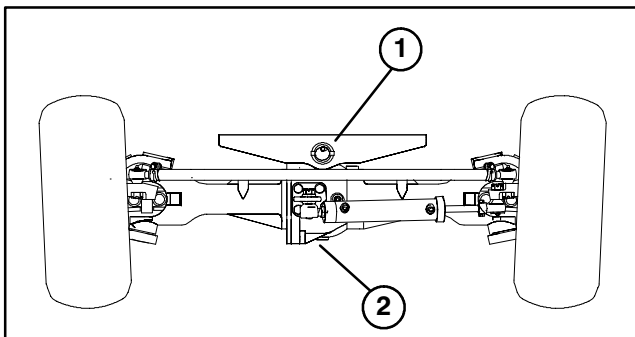

Figure 36

1. Check Plug
2. Drain Plug

3. Remove check plug to ease draining of oil.
4. Remove drain plug allowing oil to drain into pan.
5. Install drain plug.
6. Fill axle with approximately 16 oz. of Mobile 424 or until lubricant is up to bottom of check hole.
7. Install check plug.

REAR WHEEL TOE-IN (Fig. 37)

After every 800 operating hours or annually, check rear wheel toe-in.

1. Measure center-to-center distance (at axle height) at front and rear of steering tires. Front measurement must be 1/8 in. less than rear measurement.
2. To adjust toe-in:
 - A. Remove cotter pins and nuts securing ball joints to steering arms. Separate ball joint from arm.
 - B. Loosen clamps at both ends of tie rod.
 - C. Rotate ball joints to move front of tire inward or outward.
 - D. Tighten tie rod clamps when adjustment is correct.

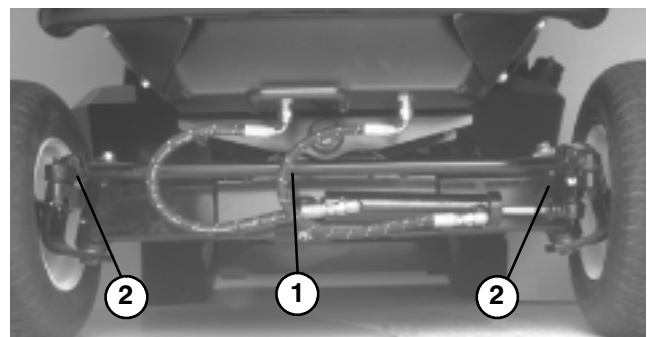

Figure 37

1. Tie Rod
2. Tie Rod Clamps

ELECTRICAL MAINTENANCE

BATTERY CARE

(Fig. 38 & NO TAG)

Check battery condition weekly or after every 50 hours of operation. Keep terminals and entire battery case clean because a dirty battery will discharge slowly. To clean the battery, wash the entire case with solution of baking soda and water. Rinse with clear water. Coat the battery posts and cable connectors with Grafo 112X (skin-over) grease (Toro Part No. 505-47) or petroleum jelly to prevent corrosion.

IMPORTANT: Before welding on the machine, disconnect both cables from the battery and the terminal connector from the alternator to prevent damage to the electrical system.

1. Remove strap, cover and foam block to access battery.

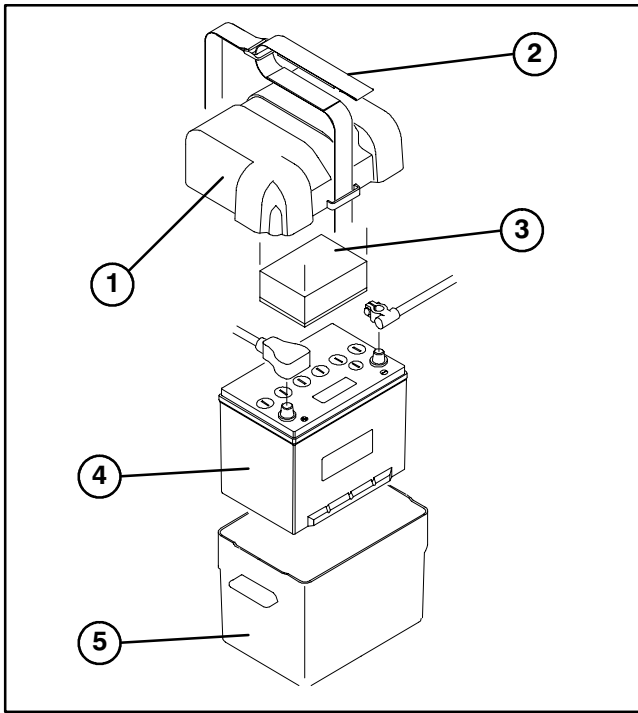

Figure 38

1. Battery Cover
2. Strap
3. Foam block
4. Battery
5. Tray



CAUTION

Wear safety goggles and rubber gloves when working with electrolyte. Charge the battery in a well ventilated so gases produced while charging can dissipate. Since the gases are explosive, keep open flame and electrical spark away from the battery; do not smoke. Nausea may result if the gases are inhaled. Unplug charger from electrical outlet before connecting to, or disconnecting charger leads from battery posts.

FUSES (Fig. 39)

There are 5 fuses in the machines electrical system. Four fuses are located in compartment rear of control panel and one (80 amp) fuse is located by alternator.

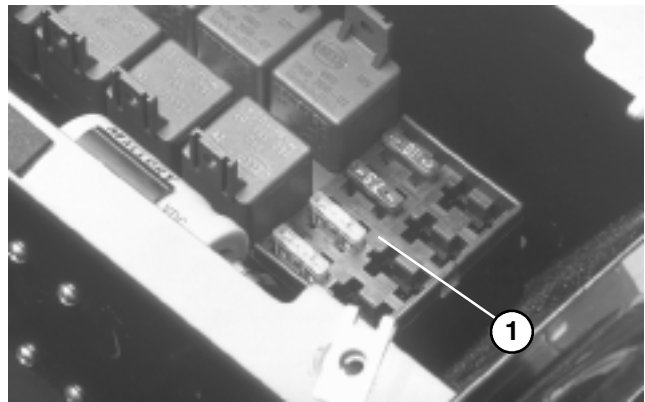
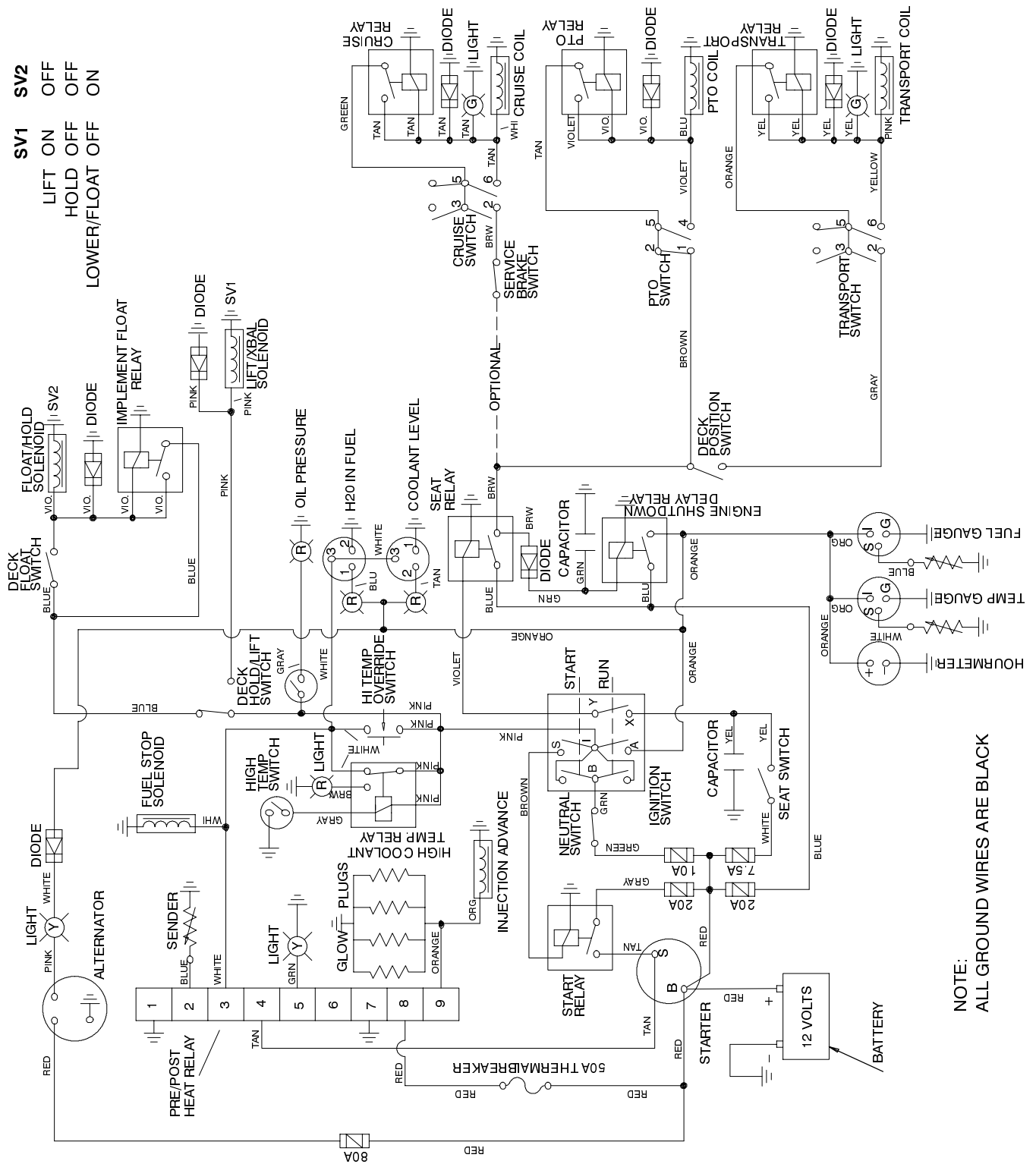

Figure 39

1. Fuses

5A ACCESSORY	STARTER 20A SOLENOID	HIGH COOLANT TEMP RELAY	TRANSPORT RELAY	IMPLEMENT FLOAT RELAY	CRUISE RELAY (OPTIONAL)
LIGHT 20A KIT	PTO 20A TRANSPORT				
IMPLEMENT 5A	SEAT 7.5A SWITCH	START RELAY	PTO RELAY	SEAT RELAY	ENGINE SHUTDOWN DELAY RELAY
IMPLEMENT 25A THERMAL BREAKER	IGNITION 10A SWITCH				80-5622

ELECTRICAL SCHEMATIC



NOTE:
ALL GROUND WIRES ARE BLACK

PREPARATION FOR SEASONAL STORAGE

Traction Unit

1. Thoroughly clean the traction unit, cutting units and the engine.
2. Check the tire pressure. Inflate all tires to 15–20 psi.
3. Check all fasteners for looseness; tighten as necessary.
4. Grease or oil all grease fittings and pivot points. Wipe up any excess lubricant.
5. Lightly sand and use touch–up paint on painted areas that are scratched, chipped, or rusted. Repair any dents in the metal body.
6. Service the battery and cables as follows:
 - a. Remove the battery cables from the battery posts.
 - b. Clean the battery, posts and cable connections with a wire brush and baking soda solution.
 - c. Coat the cable terminals and battery posts with Grafo 112X skin–over grease (Toro Part No. 505-47) or petroleum jelly to prevent corrosion.
 - d. Slowly recharge the battery every 60 days for 24 hours to prevent lead sulfation of the battery.

Engine

1. Drain the engine oil from the oil pan and replace the drain plug.
2. Remove and discard the oil filter. Install a new oil filter.
3. Refill oil pan with 4.75 quarts of SAE15W-40 CE motor oil.
4. Start the engine and run at idle speed for approximately two minutes.
5. Stop the engine.
6. Re–secure all fuel system fittings.
7. Thoroughly clean and service the air cleaner assembly.
8. Seal the air cleaner inlet and the exhaust outlet with weatherproof tape.
9. Check anti freeze protection and add a 50/50 solution of water and Peugeot recommended anti freeze, Part No. 93–7213, as needed for expected minimum temperature in your area.

NOTES

The Toro Commercial Products Two Year Limited Warranty

The Toro Company warrants your 1996 or newer Toro Commercial Product ("Product") purchased after January 1, 1997, to be free from defects in materials or workmanship for the period of time listed below. Where a warrantable condition exists, Toro will repair the Product at no cost to you including diagnosis, labor, parts, and transportation. This warranty begins on the date the Product is delivered to the original retail purchaser.

Warranty Duration: Two years or 1500 operational hours*, whichever occurs first.

***Product equipped with hour meter**

Owner Responsibilities:

As the Product owner, you are responsible for required maintenance and adjustments stated in your Owner's Manual. Failure to perform required maintenance and adjustments can be grounds for disallowing a warranty claim.

Instructions for Obtaining Warranty Service:

You are responsible for notifying the Commercial Products Distributor or Authorized Commercial Products Dealer from whom you purchased the Product as soon as you believe a warrantable condition exists.

If you need help locating a Commercial Products Distributor or Authorized Dealer, or if you have questions regarding your warranty rights or responsibilities, you may contact us at:

Toro Commercial Products Service Department
8111 Lyndale Avenue South
Minneapolis, MN, 55420-1196
Telephone: (612) 888-8801
Facsimile: (612) 887-8258
E-Mail: Commercial.Service@Toro.Com

Maintenance Parts:

Parts scheduled for replacement as required maintenance ("Maintenance Parts"), are warranted for the period of time up to the scheduled replacement time for that part.

Items/Conditions Not Covered:

Not all product failures or malfunctions that occur during the warranty period are defects in materials or workmanship. The items / conditions listed below are not covered by this warranty:

- Product failures which result from the use of non-Toro replacement parts, or from installation and use of add-on, modified, or unapproved accessories are not covered.
- Product failures which result from failure to perform required maintenance and/or adjustments are not covered.
- Product failures which result from operating the Product in an abusive, negligent or reckless manner are not covered.

- This warranty does not apply to parts subject to consumption through use unless found to be defective. Examples of parts which are consumed, or used up, during normal Product operation include, but are not limited to, blades, reels, bedknives, tines, spark plugs, castor wheels, tires, filters, belts, etc.
- This warranty does not apply to failures caused by outside influence. Items considered to be outside influence include, but are not limited to, weather, storage practices, contamination, use of unapproved coolants, lubricants, additives, or chemicals, etc.
- This warranty does not apply to normal "wear and tear" items. Normal "Wear and Tear" includes, but is not limited to, damage to seats due to wear or abrasion, worn painted surfaces, scratched decals or windows, etc.

Other Legal Disclaimers:

The above remedy of product defects through repair by an authorized distributor or dealer is the purchaser's sole remedy for any defect. This warranty gives you specific legal rights, and you may also have other rights which vary from state to state.

Except for the Emissions warranty referenced below, if applicable, there is no other express warranty. All implied warranties of merchantability and fitness for use are limited to the duration of the express warranty.

Some states do not allow limitations on how long an implied warranty lasts, so the above limitation may not apply to you.

The Toro Company is not liable for indirect, incidental or consequential damages in connection with the use of the Product, including any cost or expense of providing substitute Product or service during periods of malfunction or non-use.

Some states do not allow the exclusion of incidental or consequential damages, so the above exclusion may not apply to you.

Note to California residents: The Emissions Control System on your Product may be covered by a separate warranty meeting requirements established by the U.S. Environmental Protection Agency (EPA), or the California Air Resources Board (CARB). The hour limitations set forth above do not apply to the Emissions Control System Warranty. Refer to the California Emission Control Warranty Statement printed in your Owner's Manual or contained in the engine manufacturer's documentation for details.