



Dual Wheel Kit

Wheelhorse® 5xi Garden Tractors

Part No. 94-2050

Installation Instructions

Loose Parts

Note: Use the chart below to identify parts for assembly.

DESCRIPTION	QTY.	USE
Wheel hub	2	Installing the wheel hubs
Bolt, 1/2 x 1-1/4 in.	4	
Nut, 1/2 in	4	
Key	2	
Adaptor	2	Installing the dual wheels
Carriage bolt, 1/2 x 13 in.	8	
Locknut, 1/2 in.	8	
Washer	8	

Removing the Rear Wheels

- Using a jack or suitable hoist, raise the rear of the tractor until the rear wheels are off of the ground.
- Remove the 10 lug bolts securing the wheels and the wheels, saving them for future use (Fig. 1).

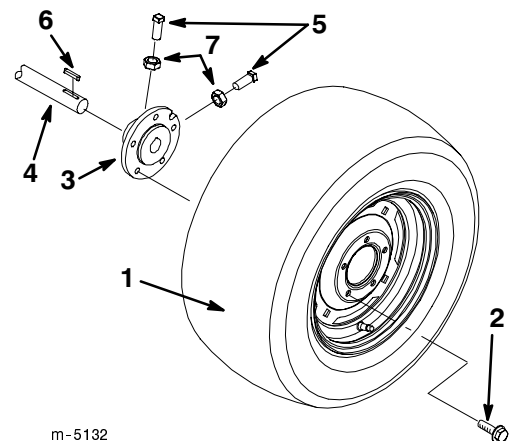

Figure 1

- | | |
|---------------|------------------------|
| 1. Wheel | 5. Hub retaining bolts |
| 2. Lug bolt | 6. Key |
| 3. Hub | 7. Jam nuts |
| 4. Axle shaft | |

- Loosen the jam nuts securing the four hub retaining bolts (Fig. 1).

4. Remove the hub retaining bolts (Fig. 1).
 5. Remove the wheel hubs (Fig. 1).
- Note:** You may need to use a puller to remove the hubs.
6. Discard the hubs, retaining bolts, jam nuts, and keys.

Installing the Rear Wheels

1. Thread the new jam nuts onto the 4 new bolts (1/2 x 1-1/4 in.) (Fig. 1).
2. Slide the new keys into the slots on the axle shafts (Fig. 1).
3. Slide the hubs over the rear axle shaft so that the keys side into the slots in the hubs. Push the hubs onto the shafts until the faces of the hubs are flush with the faces of the shafts (Fig. 1).

4. Thread the bolts and jam nuts into the holes in the hubs (Fig. 1).
5. Torque the bolts to 60 to 90 ft.-lb. (82 to 122 N·m).
6. Tighten the jam nuts against the hubs (Fig. 1).
7. Place the wheels over the hubs and install them with the lug bolts removed previously (Fig. 1).
8. Torque the lug bolts to 75 to 80 ft.-lb. (105 to 112 N·m).

Installing the Dual Wheels

1. Install each dual wheel using an adaptor, 4 carriage bolts, 4 locknuts, and 4 washers as shown in Figure 2.
2. Tighten all 8 locknuts securely.
3. Lower the tractor to the ground.

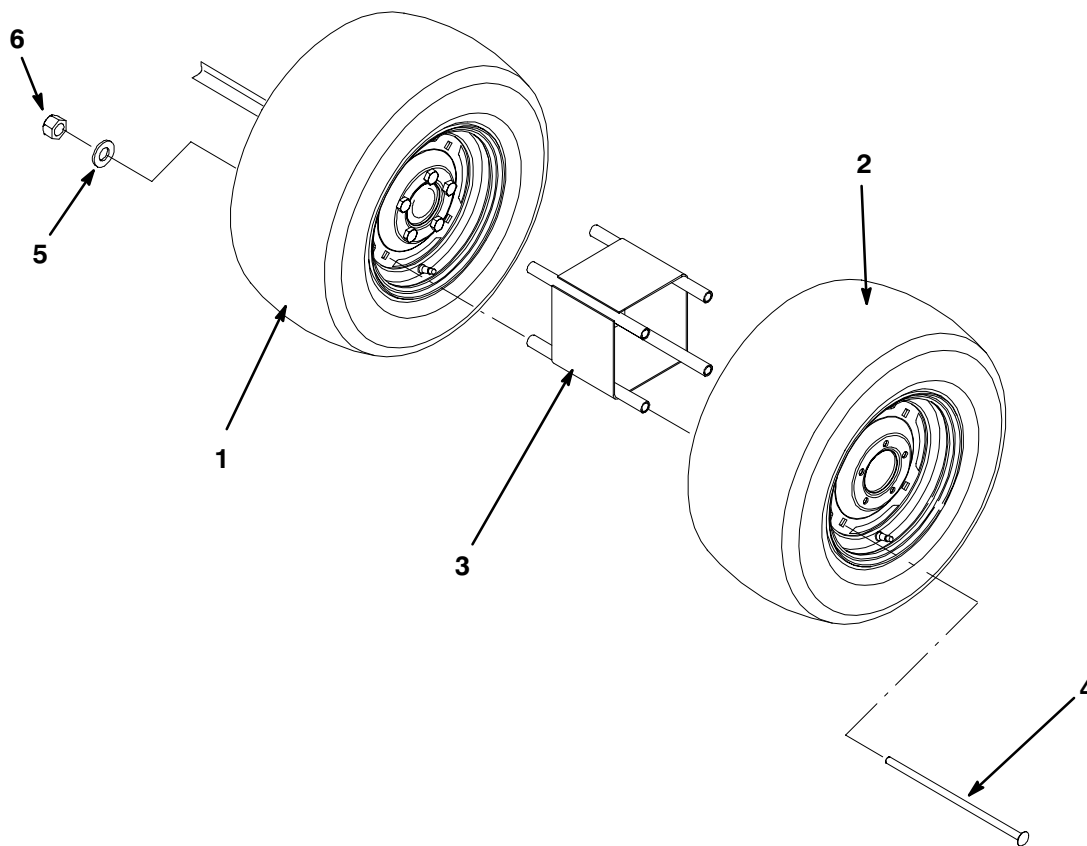

m-5133

Figure 2

- | | | | |
|---------------|------------------|-----------|------------|
| 1. Rear wheel | 3. Adaptor | 5. Washer | 6. Locknut |
| 2. Dual wheel | 4. Carriage bolt | | |