



ZT-4400

Service and Repair Manual

BLN-0081
January 2018

TABLE OF CONTENTS

Foreword.....	1	Return to Neutral Assembly Option....	17
Description and Operation.....	2	Control Arm Assembly.....	18
Introduction.....	2	Filter and Filter Cover.....	19
<u>General Description</u>	<u>2-6</u>	Brake Assembly.....	20
Hydraulic Schematic.....	3	Bypass Actuator.....	21
External Features.....	4	Side Housing.....	22
Technical Specifications.....	6	Axle Shaft and Planetary Gear Set....	23
Product Identification.....	6	Reduction Gears.....	24
		Remove Filter Tube.....	25
		Input Shaft.....	26
<u>Safety</u>	<u>7</u>	Swashplate.....	27
Personal Safety.....	7	Center Section.....	28
Tool Safety.....	7	Motor Shaft Assembly.....	29
Work Area Safety.....	7	Brake assembly.....	30
Servicing Safety.....	7	Thrust Bearing.....	31
		Inspecting the Hydraulic components..	32
<u>Troubleshooting</u>	<u>8</u>	Shock Valves, Charge Relief, Charge Pump, Magnet.....	33
		Assembly After a Complete Teardown.	34
<u>Service and Maintenance</u>	<u>9-12</u>	Sealant Application.....	35
Fluid Change Procedure.....	10	Side Housing – Screw Tightening Sequence.....	36
Purging Procedure.....	11	Castle Nut (113) Alternate Torque Method.....	37
Return to Neutral Setting.....	12		
		ZT-4400 Exploded View.....	38
<u>Tear Down and Reassembly</u>	<u>13-37</u>	ZT-4400 Transaxle Parts List.....	39
Transaxle Removal.....	14		
Tools.....	15	Glossary of Terms.....	40-41
Torques.....	15		
Fan and Pulley.....	16		
Axle Hub Assembly.....	16		

FOREWORD

Headquartered in Sullivan, Illinois, Hydro-Gear is a world leader in the design, manufacture, and service of quality hydrostatic transaxles for the lawn and garden industry. The mission of our company is to be recognized by our customers and the industry as a world-class supplier and the quality leader in everything we do.

This Service and Repair Manual is designed to provide information useful in servicing and troubleshooting the Hydro-Gear® ZT-4400. Also included is a glossary of terms that are frequently used throughout the industry and in Hydro-Gear service publications. Understanding terminology is very important!

It is necessary, and a good shop practice, that your service area be equipped with the proper tools and the mechanics be supplied the latest information available. All repair procedures illustrated in this guide are suggested, but preferred methods of repair.

Internal repair procedures require that the transaxle unit be removed from the vehicle.

This is not a certification, test or study guide for a certification test. If a technician is interested in certification, they should contact an agent representing the EETC (Equipment and Engine Training Council) by phone at (888) 406-1810, visit the EETC website at www.EETC.org, or their Hydro-Gear Central Service Distributor. Many distributors will be hosting certification testing. These study guides will cover most of the products and manufacturers in our industry.

For more information about Hydro-Gear or our products, please contact your Central Service Distributor.

DESCRIPTION AND OPERATION

INTRODUCTION

The purpose of this manual is to provide information useful in servicing the Hydro-Gear® ZT-4400® Hydrostatic Transaxle. This manual includes the ZT-4400's general description, hydraulic schematic, technical specifications, servicing and troubleshooting procedures.

Should servicing be required, the exterior of the transaxle will need to be thoroughly cleaned before beginning most procedures. Do not wash the transaxle immediately after use. **Do not use a pressure washer to clean the unit.**

GENERAL DESCRIPTION

The ZT-4400 is a self contained unit designed for the transfer and control of power. It provides an infinitely variable speed range between zero and maximum in both forward and reverse modes of operation.

This transaxle uses a variable displacement pump with a maximum displacement of 12cc per revolution, the maximum total displacement of the motor is 16.4 cc per revolution at full stroke. The variable displacement pump features a trunnion mounted swashplate with a direct-proportional displacement control. Reversing the direction of the swashplate reverses the flow of oil from the pump and thus reverses the direction of the motor output rotation. The pump and motor are of the axial piston design and utilize spherical nosed pistons which are held against a thrust race by internal compression springs.

The ZT-4400 has a self contained fluid supply

and an internal filter. The fluid is forced through the filter with an assist by the negative pressure created in the pump pistons as they operate.

The check valves in the center section are used to control the makeup flow of the fluid to the low pressure side of the loop.

A hydraulic bypass is utilized in the ZT-4400 to permit moving the vehicle for a short distance at a maximum of 2 m.p.h. (3.2 Km/h) without starting the engine.

The ZT-4400 utilizes an internal in-line floating disc brake controlled by a "cam" style actuating arm.

DESCRIPTION AND OPERATION (CONTINUED)

HYDRAULIC SCHEMATIC

Figure 1 is a schematic of the hydraulic oil circuit. The oil supply for the hydraulic system of the ZT-4400 is also utilized for lubricating the components of the final drive assembly.

The input shaft and pump cylinder block are turned in one direction only by the engine/drive belt/pulley combination. Output of the oil flow is controlled by the direction and amount that the variable swashplate is angled. As the pump pistons compress they force the oil to flow through one of two passageways (forward or reverse) in the center section to the motor cylinder block and motor shaft. Since the motor has a fixed displacement angle it is forced to turn with the flow of oil. As the angle of the pump swashplate is increased the amount of oil being pumped will increase and cause a higher speed output of the

motor. Reversing the angle of the swashplate will reverse the direction of oil flow.

During the operation of the transaxle, fluid is “lost” from the hydraulic loop through leak paths designed into the product for lubrication purposes (around pistons, under the rotating cylinder blocks, etc.). This “lost” fluid returns to the transaxle housing, then is pulled back into one of the check valves depending upon the direction of vehicle operation. All of this oil must pass through an internal filter.

The motor cylinder block mounts onto a splined motor shaft which drives the gear train.

The bypass feature in the ZT-4400 has a mechanical lever which lifts the motor block off of the center section running surface. This allows oil flow from the cylinder blocks to be discharged.

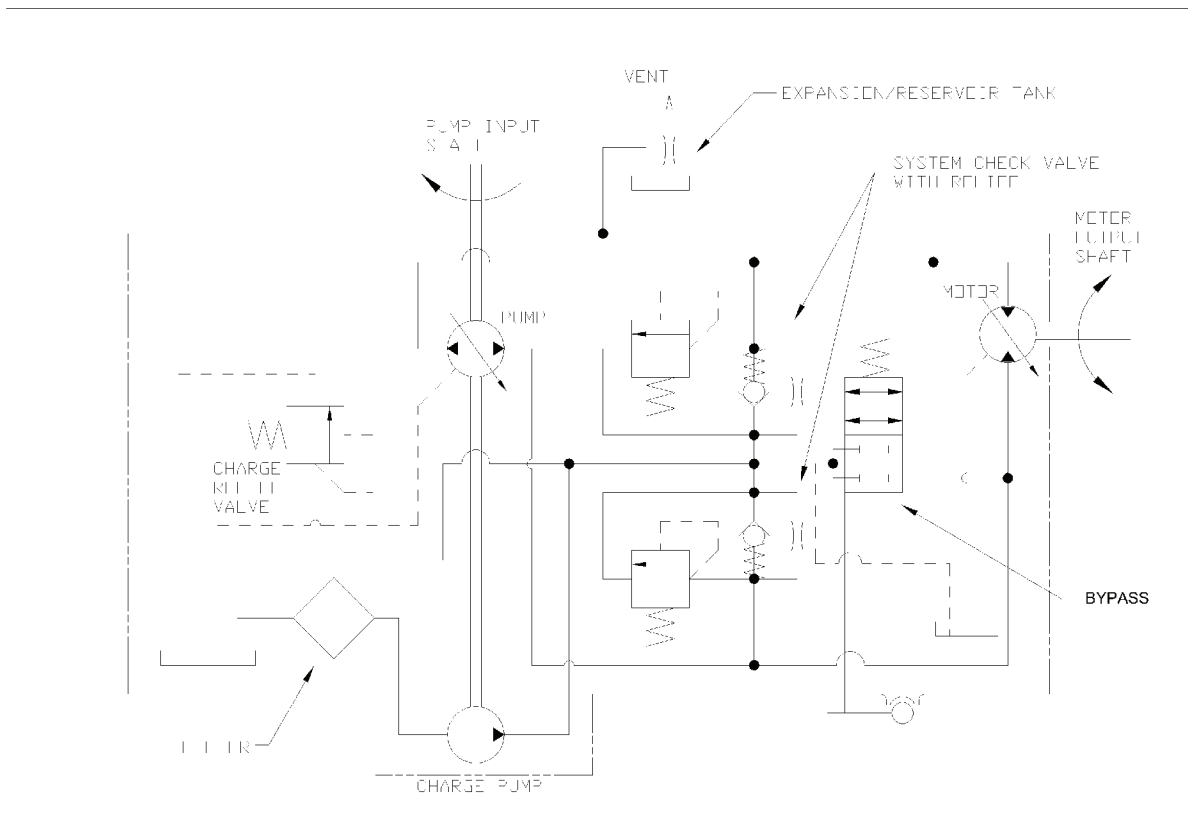
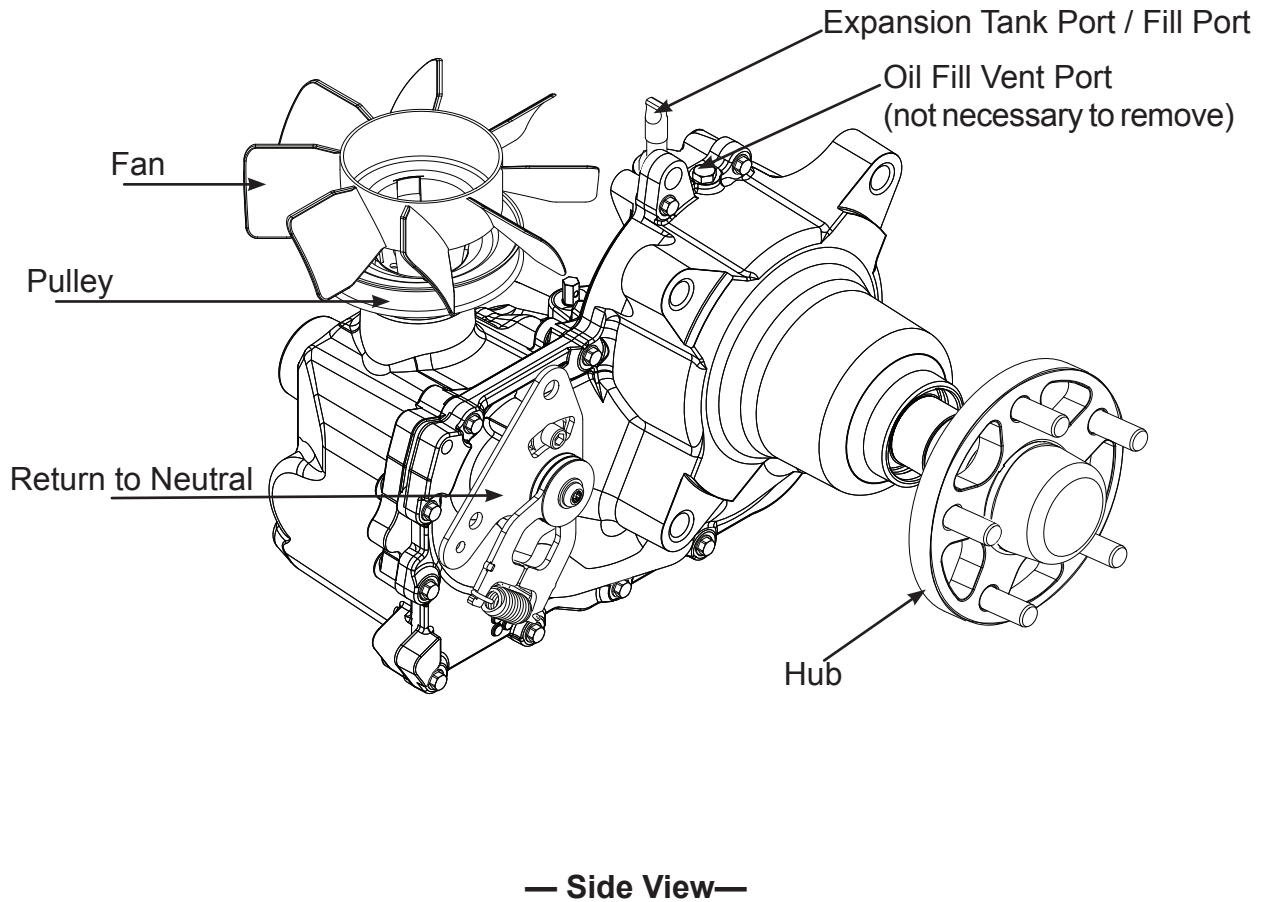
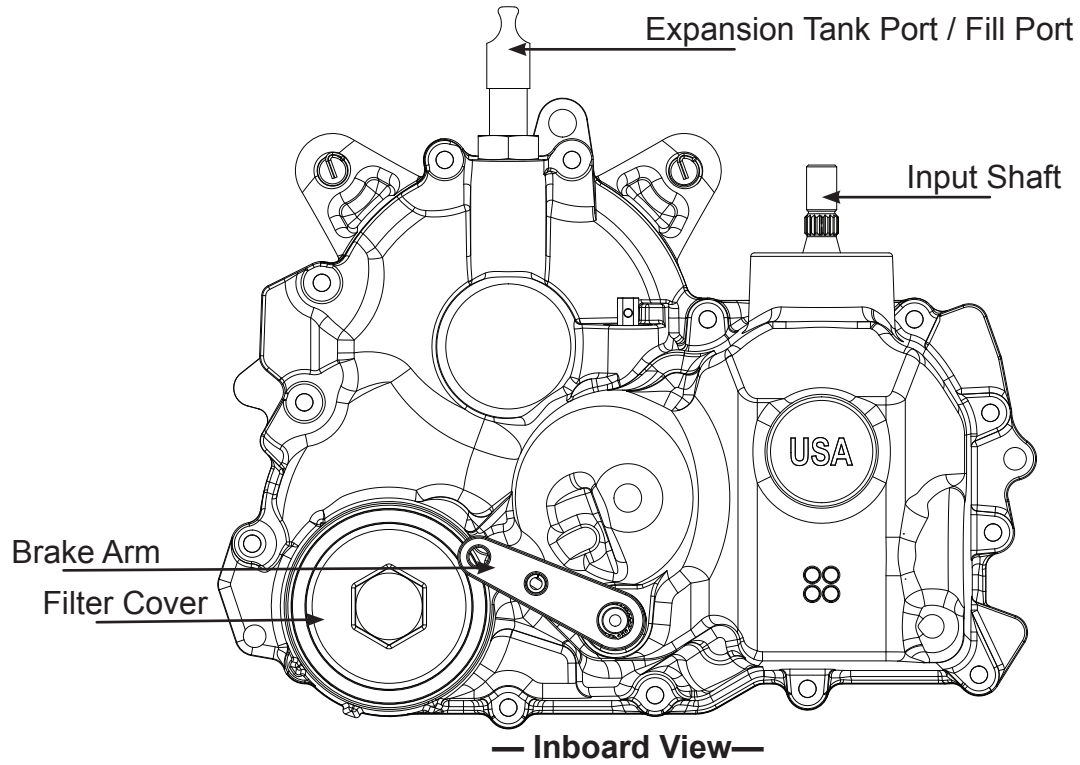
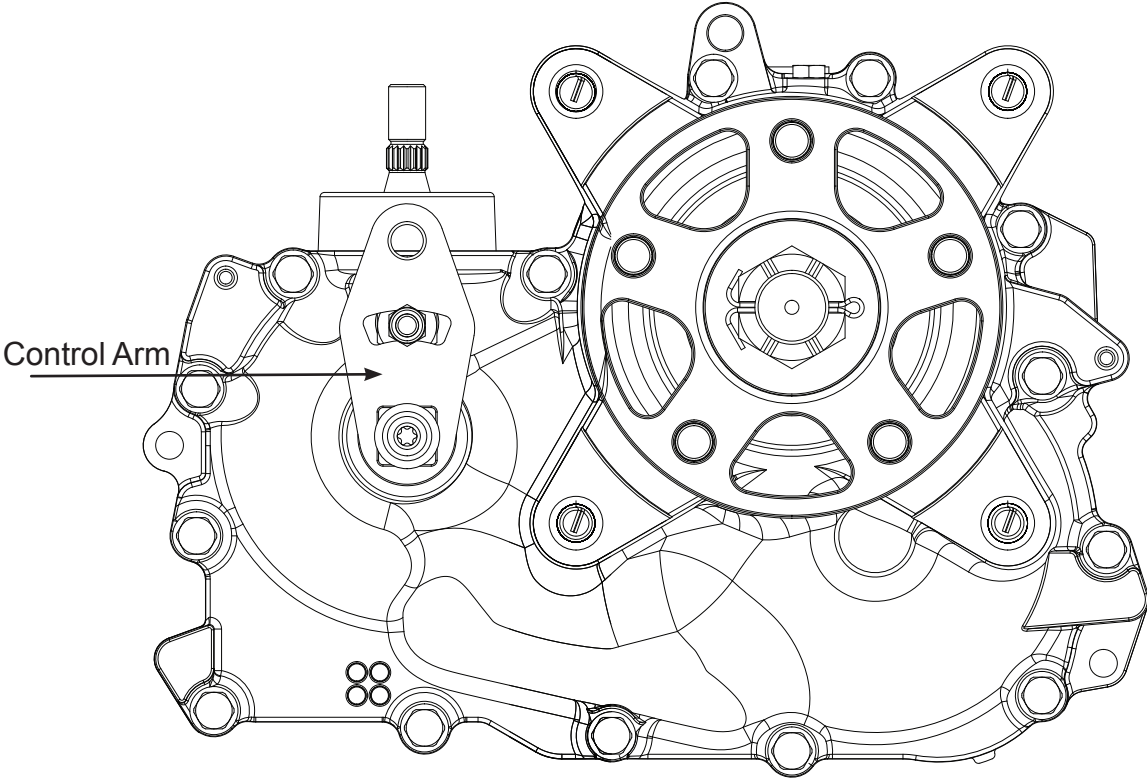

Figure 1, Hydraulic Schematic With Charge Pump

EXTERNAL FEATURES ZT-4400



EXTERNAL FEATURES ZT-4400



Control Arm

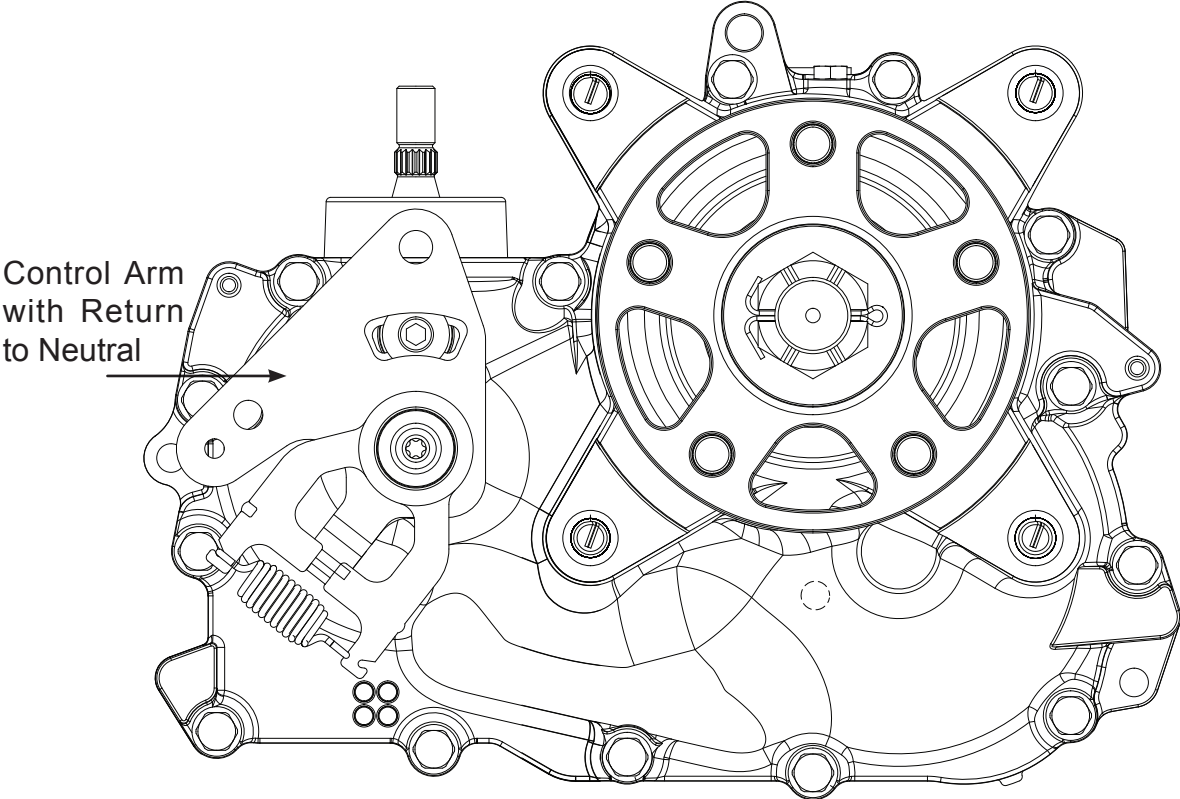

Return to Neutral

TECHNICAL SPECIFICATIONS

ZT-4400 TECHNICAL SPECIFICATIONS	
Displacement	
Pump	0.73 in ³ /rev [12cc/rev]
Motor	1.0 in ³ /rev [16.4cc/rev]
Input Speed	
Maximum (no load)	3600 rpm
Minimum (loaded)	1800 rpm
Weight on Tires (per unit)	720 lbs
Axle Diameter	1 3/8 INCHES [35 MM]
Parking Brake Type	INTERNAL DISK BRAKE
Weight of Unit	55 lbs [25 kg]

PRODUCT IDENTIFICATION

The model and configuration of the ZT-4400 can be determined from the label shown below.

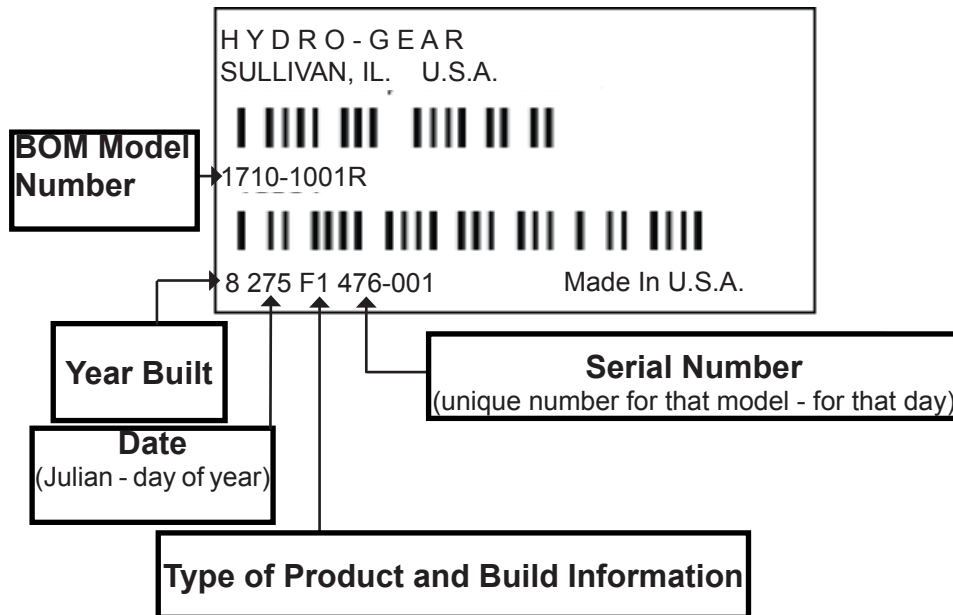

Figure 2, Configuration Label

SAFETY



This symbol points out important safety instructions which, if not followed, could endanger the personal safety and/or property of yourself and others. Read and follow all instructions in this manual before attempting maintenance on your transaxle. When you see this symbol - **HEED ITS WARNING.**



WARNING

POTENTIAL FOR SERIOUS INJURY

Inattention to proper safety, operation, or maintenance procedures could result in personal injury, or damage to the equipment. Before servicing or repairing the ZT-4400 transaxle, fully read and understand the safety precautions described in this section.

PERSONAL SAFETY

Certain safety precautions must be observed while servicing or repairing the ZT-4400. This section addresses some of these precautions but must not be considered an all-inclusive source on safety information. This section is to be used in conjunction with all other safety material which may apply, such as:

1. Other manuals pertaining to this machine,
2. Local and shop safety rules and codes,
3. Governmental safety laws and regulations.

Be sure that you know and understand the equipment and the hazards associated with it. Do not place speed above safety.

Notify your supervisor whenever you feel there is any hazard involving the equipment or the performance of your job.

Never allow untrained or unauthorized personnel to service or repair the equipment.

Wear appropriate clothing. Loose or hanging clothing or jewelry can be hazardous. Use the appropriate safety equipment, such as eye and hearing protection, and safety-toe and slip-proof shoes.

Never use compressed air to clean debris from yourself or your clothing.

TOOL SAFETY

Use the proper tools and equipment for the task.

Inspect each tool before use and replace any tool that may be damaged or defective.

WORK AREA SAFETY

Keep the work area neat and orderly. Be sure it is well lit, that extra tools are put away, trash and refuse are in the proper containers, and dirt or debris have been removed from the working areas of the machine.

The floor should be clean and dry, and all extension cords or similar trip hazards should be removed.

SERVICING SAFETY

Certain procedures may require the vehicle to be disabled in order to prevent possible injury to the servicing technician and/or bystanders.

The loss of hydrostatic drive line power may result in the loss of hydrostatic braking capability.

Some cleaning solvents are flammable. Use only approved cleaning materials: Do not use explosive or flammable liquids to clean the equipment.

To avoid possible fire, do not use cleaning solvents in an area where a source of ignition may be present.

“Discard used cleaning material in the appropriate containers according to local, state, and federal regulations.”

TROUBLESHOOTING



WARNING

Do not attempt any servicing or adjustments with the engine running. Use extreme caution while inspecting the drive belt assembly and all vehicle linkage!

Follow all safety procedures outlined in the vehicle owner's manual.

In many cases, problems with the ZT-4400 are not related to a defective transaxle, but are caused by slipping drive belts, partially engaged bypass valves, and loose or damaged control linkages. Be sure to perform all operational checks and adjustments outlined in Service and Maintenance, before assuming the transaxle is malfunctioning. The table below provides a troubleshooting checklist to help determine the cause of operational problems.

TROUBLESHOOTING CHECKLIST

Possible Cause	Corrective Action
Unit Operates In One Direction Only	
Control linkage bent or out of adjustment	Repair or replace linkage, Page 9
Drive belt slipping or pulley damaged	Repair or replace drive belt or pulley, Page 9
Vehicle Does Not Drive/Track Straight	
Vehicle tires improperly inflated	Refer to vehicle manufacturer suggested pressure
Control linkage bent or out of adjustment	Repair or replace linkage, Pages 9 and 12
Bypass assembly sticking	Repair or replace bypass, Page 23
Brake Partially Engage	Disengage Brake, Replace Broken or Missing Brake Return Spring
Unit Is Noisy	
Oil level low or contaminated oil	Fill to proper level or change oil, Page 10
Excessive loading	Reduce vehicle loading, Page 9
Loose parts	Repair or replace loose parts
Bypass assembly sticking	Repair or replace linkage, Page 9
Air trapped in hydraulic system	Purge hydraulic system, Page 11
Brake Partially Engage	Disengage Brake, Replace Broken or Missing Brake Return Spring
Unit Has No/Low Power	
Engine speed low	Adjust to correct setting
Control linkage bent or out of adjustment	Repair or replace linkage, Page 9
Drive belt slipping or pulley damaged	Repair or replace drive belt or pulley, Page 9
Oil level low or contaminated oil	Fill to proper level or change oil, Page 10
Excessive loading	Reduce vehicle loading, Page 9
Bypass assembly sticking	Repair or replace linkage, Page 9
Air trapped in hydraulic system	Purge hydraulic system, Page 11
Brake Partially Engage	Disengage Brake, Replace Broken or Missing Brake Return Spring
Unit Is Operating Hot	
Debris buildup around transaxle	Clean off debris, Page 9
Cooling fan damaged	Repair or replace cooling fan, Pages 16
Oil level low or contaminated oil	Fill to proper level or change oil, Page 10
Excessive loading	Reduce vehicle loading, Page 9
Air trapped in hydraulic system	Purge hydraulic system, Page 11
Brake Partially Engage	Disengage Brake, Replace Broken or Missing Brake Return Spring
Transaxle Leaks Oil	
Damaged seals, housing, or gaskets	Replace damaged components
Air trapped in hydraulic system	Purge hydraulic system, Page 11

SERVICE AND MAINTENANCE

NOTE: Any servicing dealer attempting a warranty repair must have prior approval before conducting maintenance of a Hydro-Gear® product unless the servicing dealer is a current Authorized Hydro-Gear Service Center.

EXTERNAL MAINTENANCE

Regular external maintenance of the ZT-4400 should include the following:

1. Check the vehicle operator's manual for the recommended load ratings. Insure the current application does not exceed load rating.
2. Check oil level in accordance with Figure 3 Page 10.
3. Inspect the vehicle drive belt, idler pulley(s), and idler spring(s). Insure that no belt slippage can occur. Slippage can cause low input speed to the transmission.
4. Inspect the transmission cooling fan for broken or distorted blades and remove any obstructions (grass clippings, leaves, dirt, etc.).
5. Inspect the parking brake and vehicle linkage to insure proper actuation and adjustment of the parking brake.
6. Inspect the vehicle control linkage to the directional control arm on transaxle. Also, insure the control arm is securely fastened to the trunnion arm of the transaxle.
7. Inspect the bypass mechanism on the transaxle and vehicle linkage to insure it actuates and releases fully.

SERVICE AND MAINTENANCE PROCEDURES

All the service and maintenance procedures presented on the following pages can be performed while the ZT-4400 is mounted on the vehicle. Any repair procedures as mentioned in the tear down and assembly section of this manual must be performed after the unit has been removed from the vehicle.

FLUIDS

The fluids used in Hydro-Gear products have been carefully selected, and only equivalent, or better products should be substituted.

Typically, an engine oil with a minimum rating of 9.0 cSt (55 SUS) at 230°F (110° C) and an API classification of SL is recommended. A 20W-50 engine oil has been selected for use by the factory and is recommended for normal operating temperatures. Biodegradable oils are not approved for this unit as they degrade too quickly while in service.

“All fluids should be handled and disposed of according to local, state, and federal regulations.”

FLUID VOLUME AND LEVEL

Fluid volume information is provided in the Table below.

Certain situations may require additional fluid to be added or even replaced. Refer to Page 10, Figure 3 and page 5 for the proper fill port location.

Fill the ZT-4400 to the top of the oil fill port.

Recheck the fluid level once the unit has been operated for approximately 1 minute.

Purging may be required. Refer to the purging procedures on page 11.

FLUID CHANGE PROCEDURE

This transaxle is designed with a serviceable filter. To ensure constant fluid quality levels and longer life, an initial oil and filter change at 100 hours is recommended. Subsequent changes are recommended at 400 hour intervals minimum, or yearly, whichever comes first.

The following procedure can be performed with the transaxle installed in the vehicle, and the vehicle on level ground. Apply the bypass valve and lock the vehicle parking brake.

1. Place an oil drain pan (12" or more in diameter and 8 qt. capacity is optimal) beneath the oil filter. Remove the oil filter cover from the transaxle to drain the oil. Remove the O-ring from the cover and discard the O-ring.
2. After the oil has drained from the transaxle, remove the oil filter from the transaxle housing.
3. Install a new filter and a new O-ring onto the filter cover and install the filter cover. See Figure 3a. See page 15 for torque specifications.
4. Fill the transaxle with new 20W50 motor oil through the expansion tank port / fill port until oil reaches the top.
5. Continue filling the system with oil until the fill line is reached in the expansion tank.
6. Drain old oil filter of all free flowing oil prior to disposal. Place used oil in appropriate containers and deliver to an approved recycling collection facility.
7. Proceed to the purge procedure on page 11.

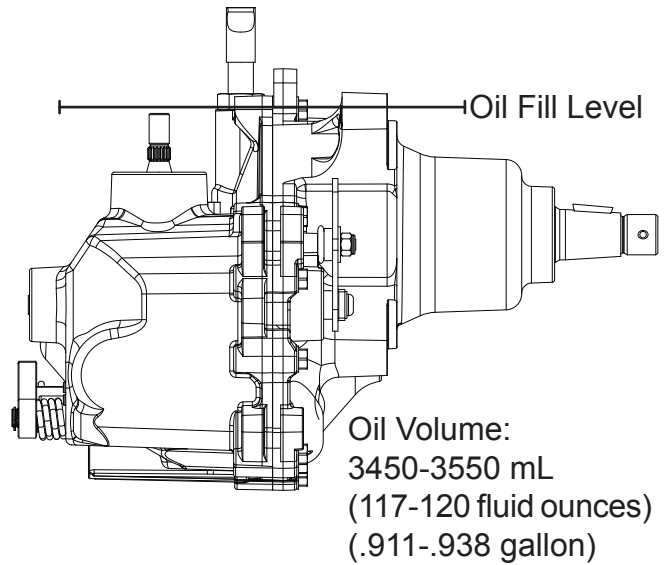

Figure 3, Oil Volume

Note: The oil volume figure shown does not include what is in the expansion tank hose or the expansion tank. That will have to be determined by the machine manufacturer/end user due to varying hose sizes/lengths and expansion tank sizes.

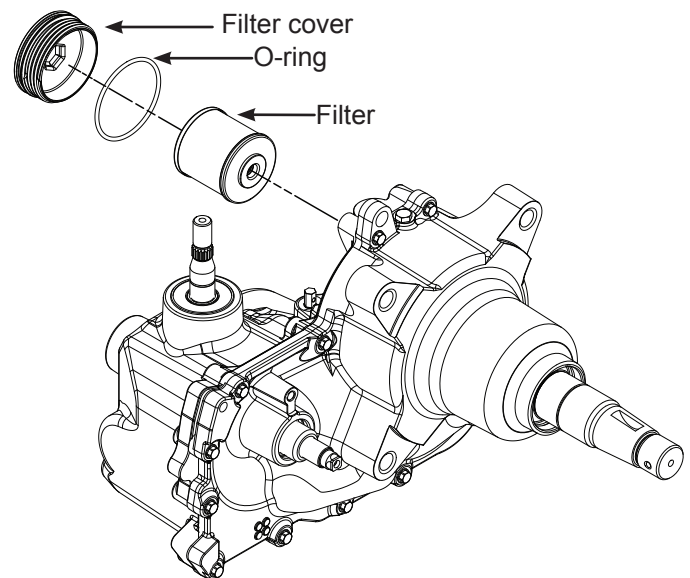

Figure 3a, Filter Components

PURGING PROCEDURE

Due to the effects air has on efficiency in hydrostatic drive applications, it is critical that it be purged from the system.

These purge procedures should be implemented any time a hydrostatic system has been opened to facilitate maintenance or any additional oil has been added to the system.

Air creates inefficiency because its compression and expansion rate is higher than that of the oil approved for use in hydrostatic drive systems.

The resulting symptoms in hydrostatic systems may be:

1. Noisy operation.
2. Lack of power or drive after short term operation.
3. High operation temperature and excessive expansion of oil.

Before starting, make sure the transaxle/transmission is at the proper oil level. If it is not, fill to the specifications outlined on page 10.

The following procedures should be performed with the vehicle drive wheels off the ground, then repeated under normal operating conditions.

1. With the bypass valve open and the engine running, slowly move the directional control in both forward and reverse directions (5 to 6 times), as air is purged from the unit, the oil level will drop.
2. With the bypass valve closed and the engine running, slowly move the directional control in both forward and reverse directions (5 to 6 times). Check the oil level, and add oil as required after stopping engine.
3. It may be necessary to repeat Steps 1 and 2 until all the air is completely purged from the system. When the transaxle moves forward and reverse at normal speed purging is complete.

RETURN TO NEUTRAL SETTING



WARNING

POTENTIAL FOR SERIOUS INJURY

Certain procedures require the vehicle engine to be operated and the vehicle to be raised off the ground. To prevent possible injury to the servicing technician and/or bystanders, insure the vehicle is properly secured.

The return to neutral mechanism on the transaxle is designed to set the directional control into a neutral position when the operator removes their hand from the control lever. Follow the procedures below to properly adjust the return to neutral mechanism on the transaxle:

1. Confirm the transaxle is in the operating mode (bypass disengaged). Raise the vehicle's drive tires off the ground to allow free rotation.

NOTE: *It may be necessary to remove the drive tire from the axle hub to access the linkage control and the transaxle return arm.*

2. Remove the Original Equipment Manufacturer's (OEM's) control linkage at the control arm.
3. Start the engine and increase the throttle to full engine speed.
4. Check for axle rotation. If the axles do not rotate, go to Step 5. If the axles rotate, go to Step 6.
5. Stop the vehicle's engine. Reattach and adjust the OEM linkage according to the OEM manual. Recheck according to Step 3 and 4. Start the vehicle engine.
6. Note the axle directional movement. Stop the vehicle engine. Loosen the lock down screw (61) until the control arm (54) can be rotated. Rotate the control arm in the opposite direction of the wheel rotation 5 degrees. Tighten the lock down screw. Recheck according to steps 3 and 4. Refer to Figure 4.

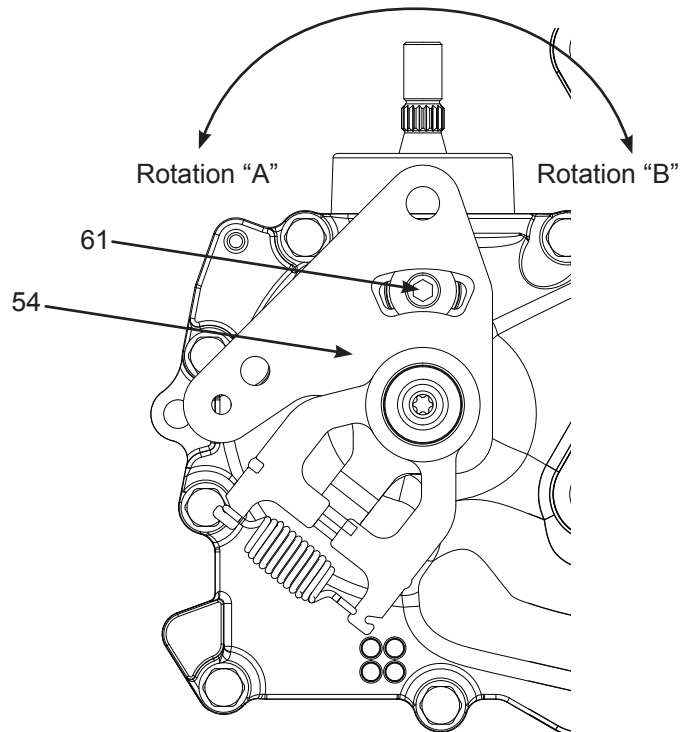

Figure 4, Return to Neutral

TEAR DOWN AND REASSEMBLY

HOW TO USE THIS MANUAL

Each subassembly illustrated in this section is illustrated by an exploded view showing the parts involved. **The item reference numbers in each illustration are for assembly instructions only.** See page 39 for part names and descriptions. A complete exploded view and item list of the transaxle is provided on pages 38 and 39.

Many of the parts and subassemblies of this transaxle can be removed and serviced independently of other components. Where some components and assemblies must be removed before a given assembly can be serviced, that information is given at the beginning of the disassembly instructions.

GENERAL INSTRUCTIONS

Cleanliness is a primary means of assuring satisfactory life on repaired units. Thoroughly clean all exposed surfaces prior to any type of maintenance. Cleaning of all parts by using a solvent wash and air drying is usually adequate. As with any precision equipment, all parts must be kept free of foreign material and chemicals.

Protect all exposed sealing surfaces and open cavities from damage and foreign material. The external surfaces should be cleaned before beginning any repairs.

Upon removal, it is required that all seals, O-rings, and gaskets be replaced. During installation lightly lubricate all seals, O-rings, gaskets with a clean petroleum jelly prior to assembly. Also protect the inner diameter of seals by covering the shaft with a cellophane (plastic wrap, etc.) material. Be sure all remnants of this covering are removed after servicing.

Anytime the tapered axle hub is removed it should be replaced by a new axle hub, insuring that the integrity of the taper lock is not lost.

Parts requiring replacement must be replaced from the appropriate kits identified in the Items Listing, found on page 39. Use only original Hydro-Gear® replacement parts found listed in the authorized dealer section of the Hydro-Gear web site (www.hydro-gear.com).

IMPORTANT: When internal repair is performed on the ZT-4400, the filter assembly must be replaced.

TRANSAXLE REMOVAL

It is necessary to remove the ZT-4400 from the vehicle before performing the repair procedures presented in this section.

LIMITED DISASSEMBLY

The following procedures are presented in the order in which they must be performed to completely disassemble the unit. Do not disassemble the unit any farther than is necessary to accomplish the required repairs. Each disassembly procedure is followed by a corresponding assembly procedure.

Reassembly is accomplished by performing the “Assembly” portions of the procedures. If the unit has been completely disassembled, a summary of the assembly procedures, in the order in which they should occur, is given on page 34.

Note: “Any and all Hydro-Gear components removed and replaced during service are recyclable.”

TRANSAXLE REMOVAL

NOTE: *It is necessary to remove the ZT-4400 from the vehicle before performing the repair procedures presented in this section.*

Before starting any disassembly, make certain that your work area is neat and clean. Clean the external parts of the transaxle.

The following procedures are presented in the order recommended for a

complete tear down of the transaxle.

Do not disassemble the unit any farther than necessary to accomplish the required repairs.

Reassembly is accomplished by performing the “Assembly” portions of the procedures. If the unit has been completely disassembled, a summary of the assembly procedures, in the order in which they should occur, is given on page 34.

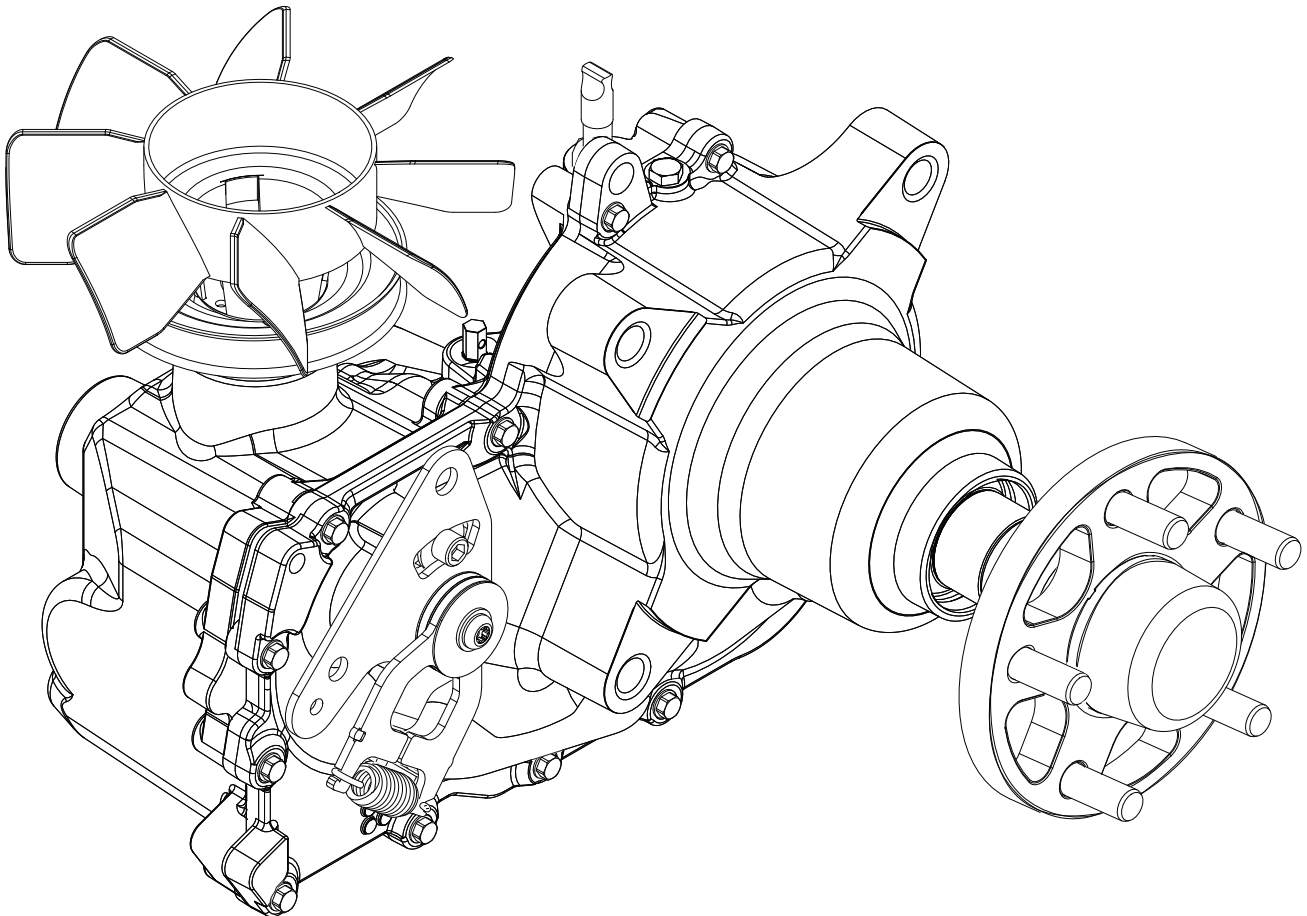

Figure 7, ZT-4400 Transaxle

TOOLS

REQUIRED TOOLS	
Miscellaneous	Sockets
3/8" Drive Ratchet	1/2" socket
Rubber Mallet	3/4" socket
Large External Retaining Ring Pliers	9/16" socket
AN-08 (1/4 Allen)	1 1/8" socket
T-25 Torx	1 7/16" socket
T-40 Torx	3/8" socket
3 Jaw Puller	

TORQUES As a general rule, use the low end of the torque spec on fasteners when reassembling the unit.

REQUIRED TORQUE VALUES			
Item	Description	Torque	Operation
17	HFHCS	280-340 in-lbs [31.6-38.4 Nm]	Housing Screw
18	Bolt, Hex Flange	450-550 in-lbs [50.8-62.1 Nm]	Center Section
19	Bolt, Hex Flange	450-550 in-lbs [50.8-62.1 Nm]	Center Section
13	Seat Check Nut	280-400 in-lbs [31.6-45.2 Nm]	Center Section
14	Check Spring Retainer	200-250 in-lbs [22.59-28.24 Nm]	Center Section
36	Bolt, Self Tapping	20-30 in-lbs [2.25-3.38 Nm]	Magnet / Filter Tube
171	Stud	50-120 in-lbs [5.7-13.5 Nm]	RTN
156	TWHCS	230-310 in-lbs [25.9-30.0 Nm]	RTN
51	SHCS	80-120 in-lbs [9.0-13.5 Nm]	Charge Cover
161	SHCS	175-200 in-lbs [19.7-22.5 Nm]	RTN
120	Castle Nut*	275-350 ft-lbs* [31.1-39.54 Nm]	Hub
87	Nut	660-800 in-lbs [74.5-90.3 Nm]	Brake Shaft
102	Plug, Oil Filter Cover	200-300 in-lbs [Nm]	Oil Filter
54	Seat, Check 9/16	150-200 in-lbs [16.9-22.5 Nm]	Charge Relief
142	Plug	32-42 in-lbs [3.6-4.7 Nm]	Oil Fill Vent Port
139	Nut, HEX, 1/2-20 W/ PATCH	540-660 in-lbs [61.6- 74.6Nm]	Fan/Pully

* If a 275 ft-lbs torque wrench is not available please use the alternative torque procedure outlined on page 37.

FAN AND PULLEY

Refer to Figure 8

1. Remove the locknut (139).
2. Remove the fan (138).
3. Remove the pulley (136).
4. Remove the pulley hub (137).

Assembly

1. Reassemble all parts in the reverse order of disassembly.
2. When tightening the lock nut (139), refer to the table on page 15 for the required torque values.

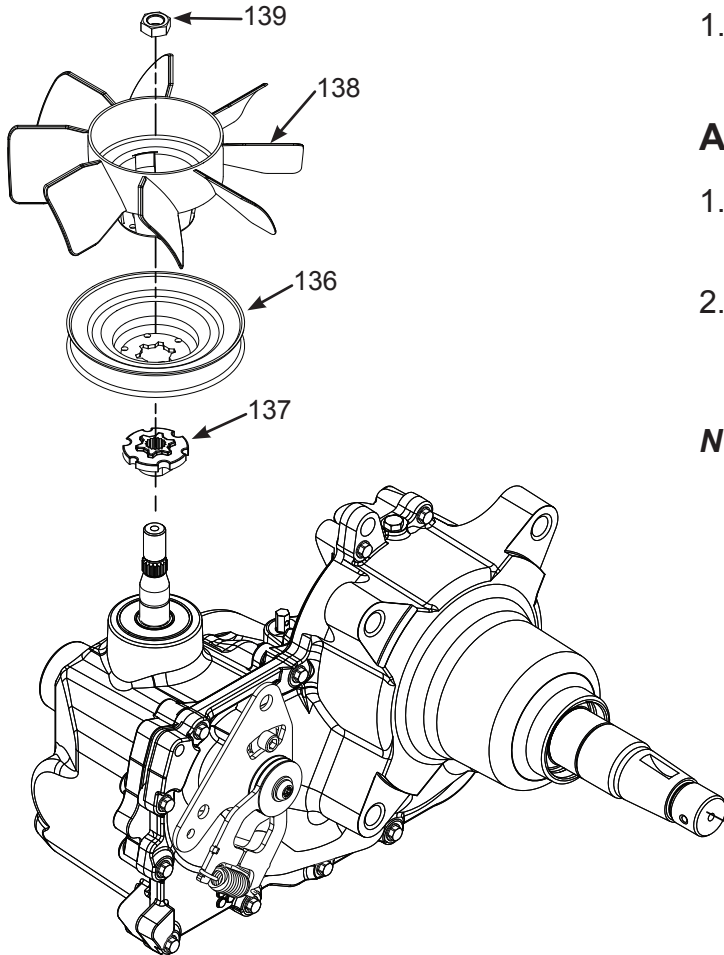

AXLE HUB ASSEMBLY

Refer to Figure 8

1. Remove the axle cap and discard (122).
2. Remove the cotter pin and discard (121).
3. Remove the castle nut (120) and washer (123).
4. Remove the taper hub assembly (118) and discard.

NOTE: A new hub will have to be ordered to replace the discarded hub.

5. Remove the axle shaft key (110).

Inspection

1. Check all components for excessive wear or damage. Replace if necessary.

Assembly

1. Reassemble all parts in the reverse order of disassembly.
2. When tightening the castle nut (120)*, refer to the table on page 15 for the required torque values.

NOTE: As a general rule, use the low end of the torque specification. Once at the specified torque, rotate castle nut clockwise to align with nearest cotter pin hole.

***SEE PAGE 37 FOR ALTERNATE TORQUE METHOD.**

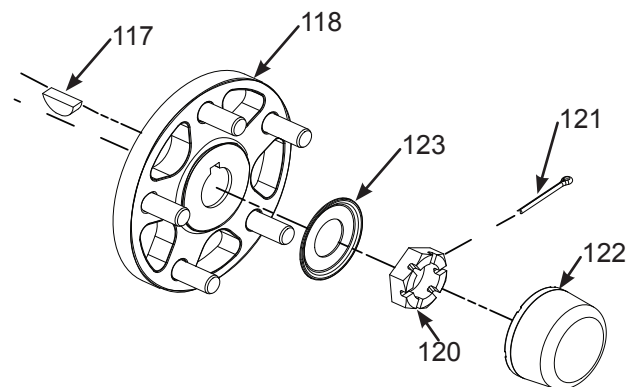

Figure 8, Fan and Hub

RETURN TO NEUTRAL ASSEMBLY OPTION

Refer to Figure 9

Disassembly

1. Remove all items previously discussed in their recommended order.
2. Remove the spring (164).
3. Remove the Torx head screw (161) and discard. Remove the washer (163).
4. Remove the scissor arm (162). Remove the Allen head screw (156) and the RTN control arm (154).
5. Remove the washer (160), neutral arm (159) and the spacer (158).
6. Remove the seal (150).

NOTE: Only remove the seal (150) if damaged or worn, or if doing a complete disassembly.

Inspection

1. Inspect all parts for excessive wear or damage. Replace if necessary.

Assembly

1. Reassemble all parts in the reverse order of disassembly.
2. When tightening the fasteners, refer to the table on page 15 for the required torque values.
3. Install new Torx head screw (161) and lip seal (150) from seal kit.

NOTE: As a general rule, use the low end of the torque specification on fasteners when reassembling the unit.

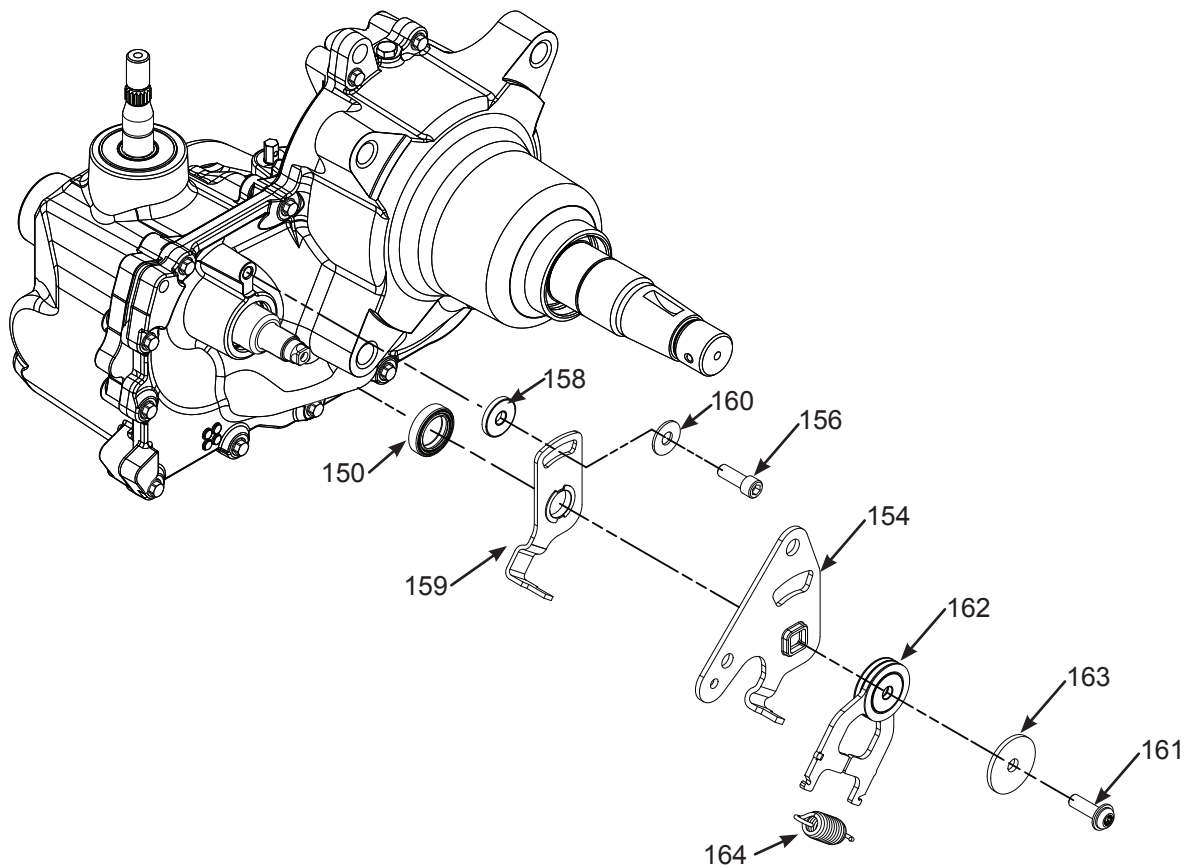

Figure 9 Return To Neutral

CONTROL ARM ASSEMBLY

Refer to Figure 10

Disassembly

1. Remove all items previously discussed in their recommended order.
2. Remove the lock nut (172) and washer (160). Discard both items.
3. Remove the Torx head screw (156) and discard.
4. Remove the control arm (154) and spacer (170).
5. Remove the stud (171) only if damaged.
6. Remove the seal (150).

NOTE: Only remove the seal (150) if damaged or worn, or if doing a complete disassembly.

Inspection

1. Inspect all parts for excessive wear or damage. Replace if necessary.

Assembly

1. Reassemble all parts in the reverse order of disassembly.
2. When tightening the fasteners, refer to the table on page 15 for the required torque values.
3. Install new Torx head screw (156) and lip seal (150) from seal kit.

NOTE: As a general rule, use the low end of the torque specification on fasteners when reassembling the unit.

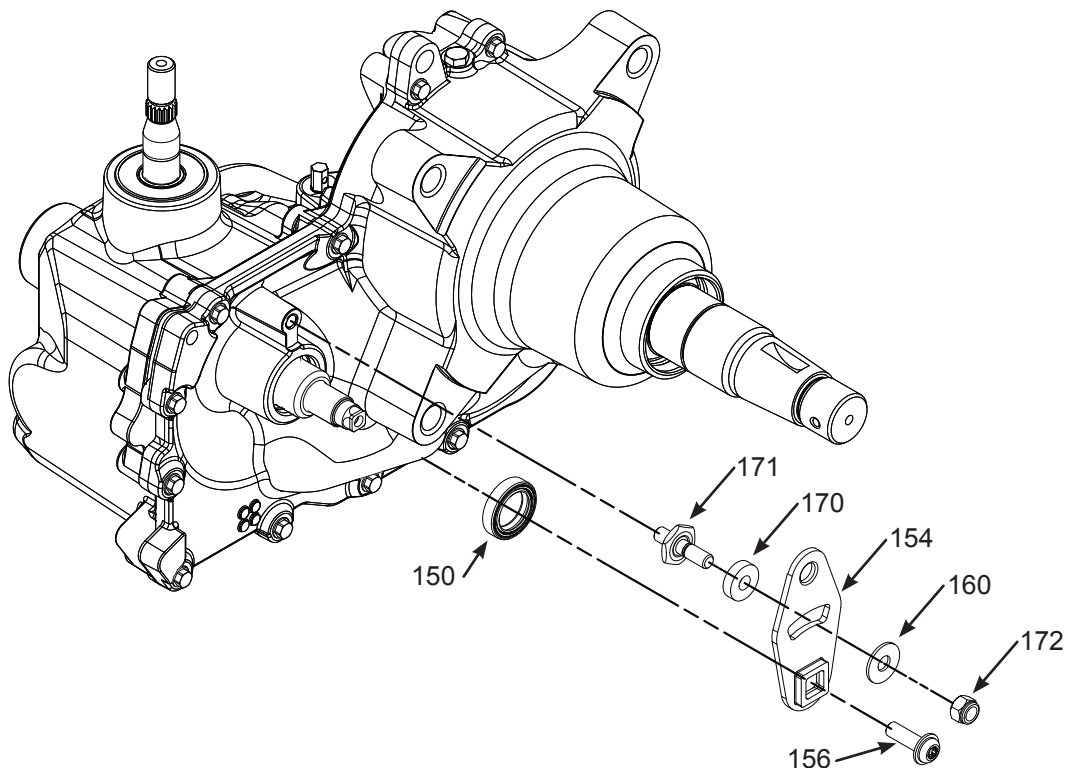

Figure 10, Control Arm

FILTER AND FILTER COVER

Refer to Figure 11

Disassembly

1. Remove the filter cover (102).
2. Remove the O-ring (101) from the cover (102) and discard.
3. Remove the filter (100) and discard.

Inspection

1. Inspect all parts for wear or damage. Replace as necessary.
2. Check for old filter grommet stuck on the filter tube. Remove if present.

Assembly

1. Install the new filter (100).
2. Install the new O-ring (101) onto the cover (102).
3. Install the filter cover (102). Refer to torque chart on page 15.

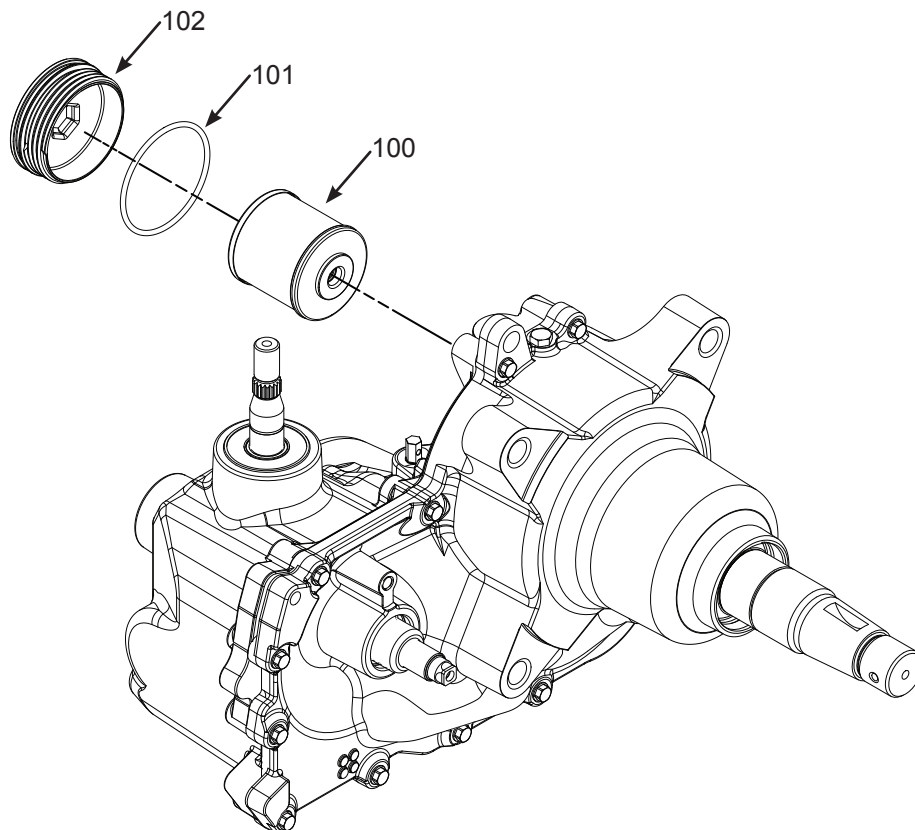

Figure 11, Filter and Filter Cover

BRAKE ASSEMBLY

Refer to Figure 12

Disassembly

1. Remove all items previously discussed in their recommended order.
2. Mark the orientation of the brake arm (191) before removal.
3. Remove the retaining ring (92) and discard.
4. Remove the brake handle (91), spring (96), and bushing (90).
5. Remove the seal (88) and discard.

NOTE: Only remove the seal (88) if damaged or worn, or if doing a complete disassembly.

Inspection

1. Inspect all parts for wear or damage. Replace as necessary.

Assembly

1. Reassemble all parts in the reverse order of disassembly.
2. Install new seal (88) from seal kit.

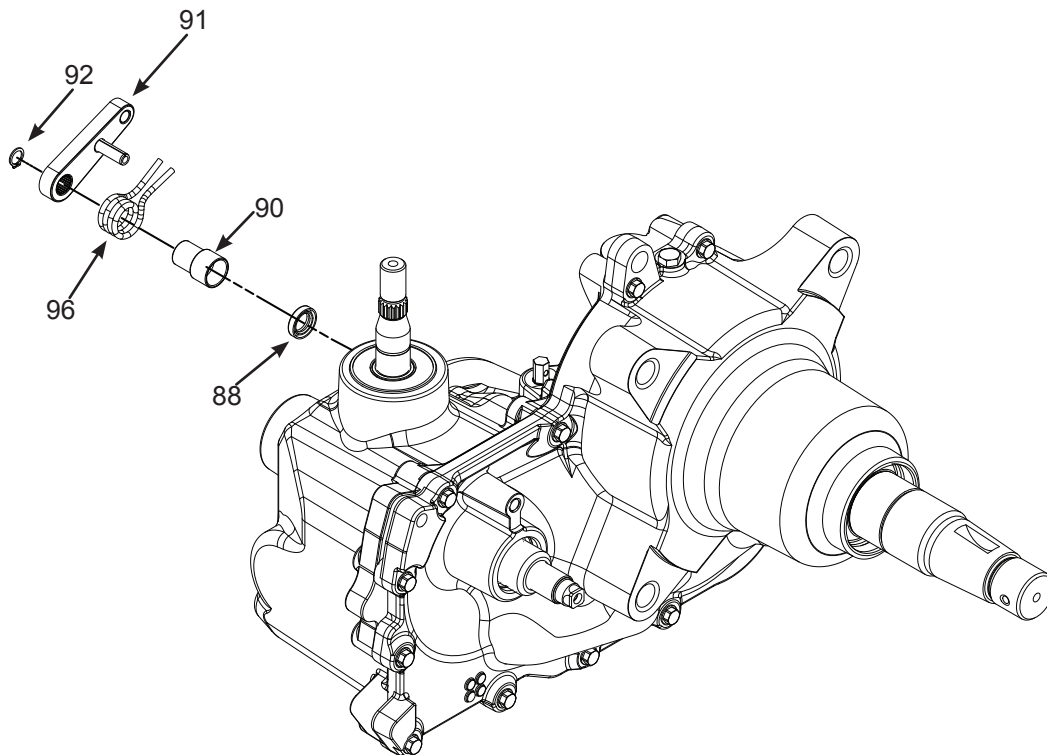

Figure 12, Brake Assembly

BYPASS ACTUATOR

Refer to Figure 14

Disassembly

1. Remove all external items previously discussed in their recommended order.
2. Remove the retaining ring (127) and discard.
3. Remove the bypass rod (126) and the clip retaining ring (128) as a single item.

NOTE: It is not necessary to remove the clip retaining ring (128) from the bypass rod (126) unless it is damaged or worn.

5. Remove the lip seal (116) and discard.

Inspection

1. Inspect the actuator bypass rod (126) for wear or damage. Replace if necessary.

NOTE: Take care to insure that the actuator bypass rod is free of burrs that may cut the lip seal.

2. Inspect the housing bore.

Assembly

1. Reassemble all parts in the reverse order of disassembly.
2. Install a new lip seal (116).
3. Install the bypass rod (126) and the clip retaining ring (128) as a single item.
5. Install the new retaining ring (127).

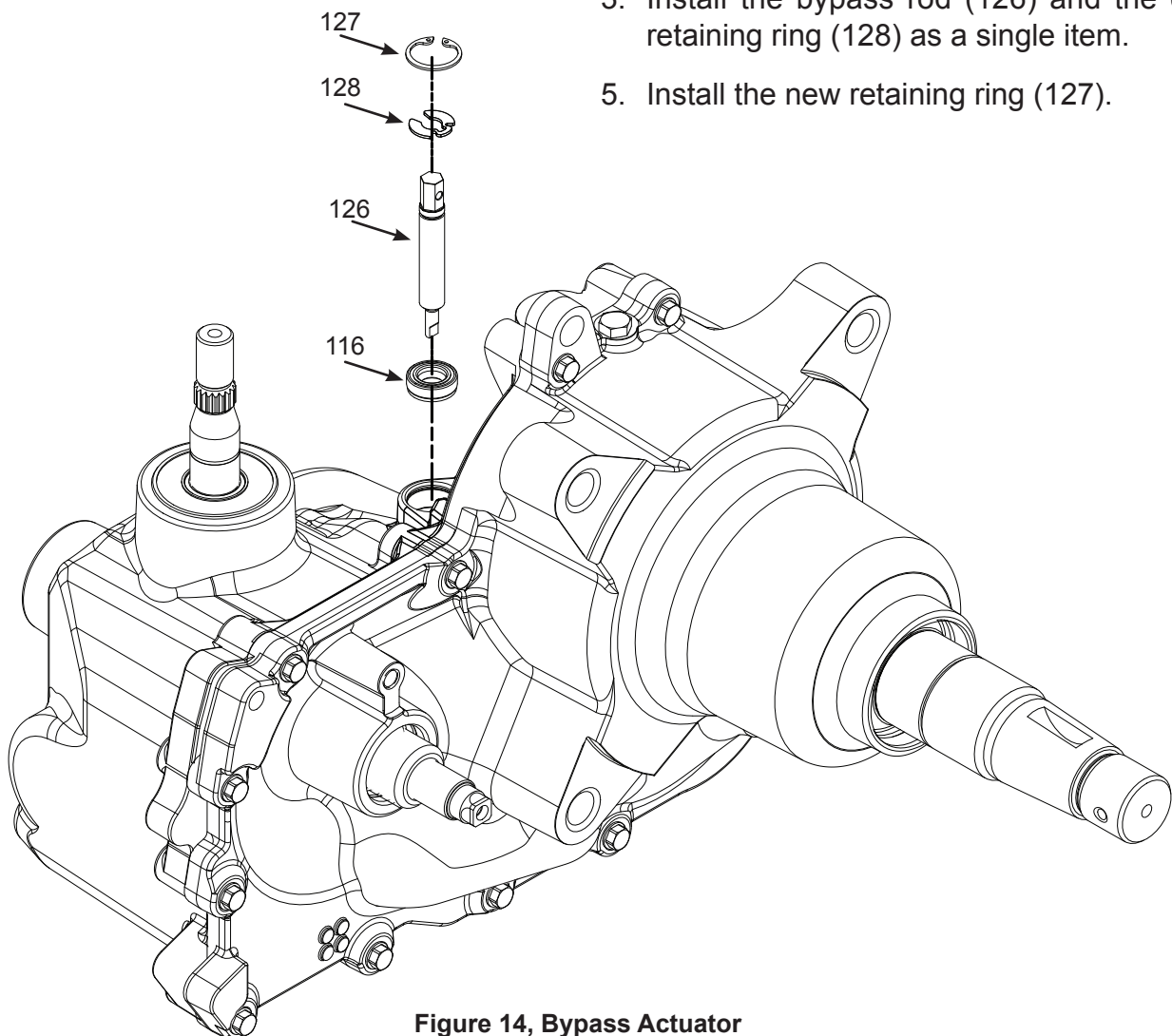

Figure 14, Bypass Actuator

SIDE HOUSING

Refer to Figure 15

Disassembly

1. Remove all external items previously discussed in their recommended order.
2. Remove the screws (17), then separate side housing from main housing.
3. Remove the axle shaft seal (115) and trunion seal (150). Discard both seals.

Inspection

1. Inspect the bearing and bushing areas in the side cover for excessive wear or damage. Replace housing necessary.

Assembly

1. Reassemble all parts in the reverse order of disassembly.
2. Install new seals (115 and 150).
3. Apply a bead of sealant around the perimeter of the main housing face. See "Sealant Application Diagram" on page 34.
4. Align the side housing with the main housing. Use care not to smear the sealant bead.
5. Install the seventeen housing screws (17). Refer to the screw tightening pattern on page 35.
6. When tightening the fasteners, refer to the table on page 15 for the required torque values.

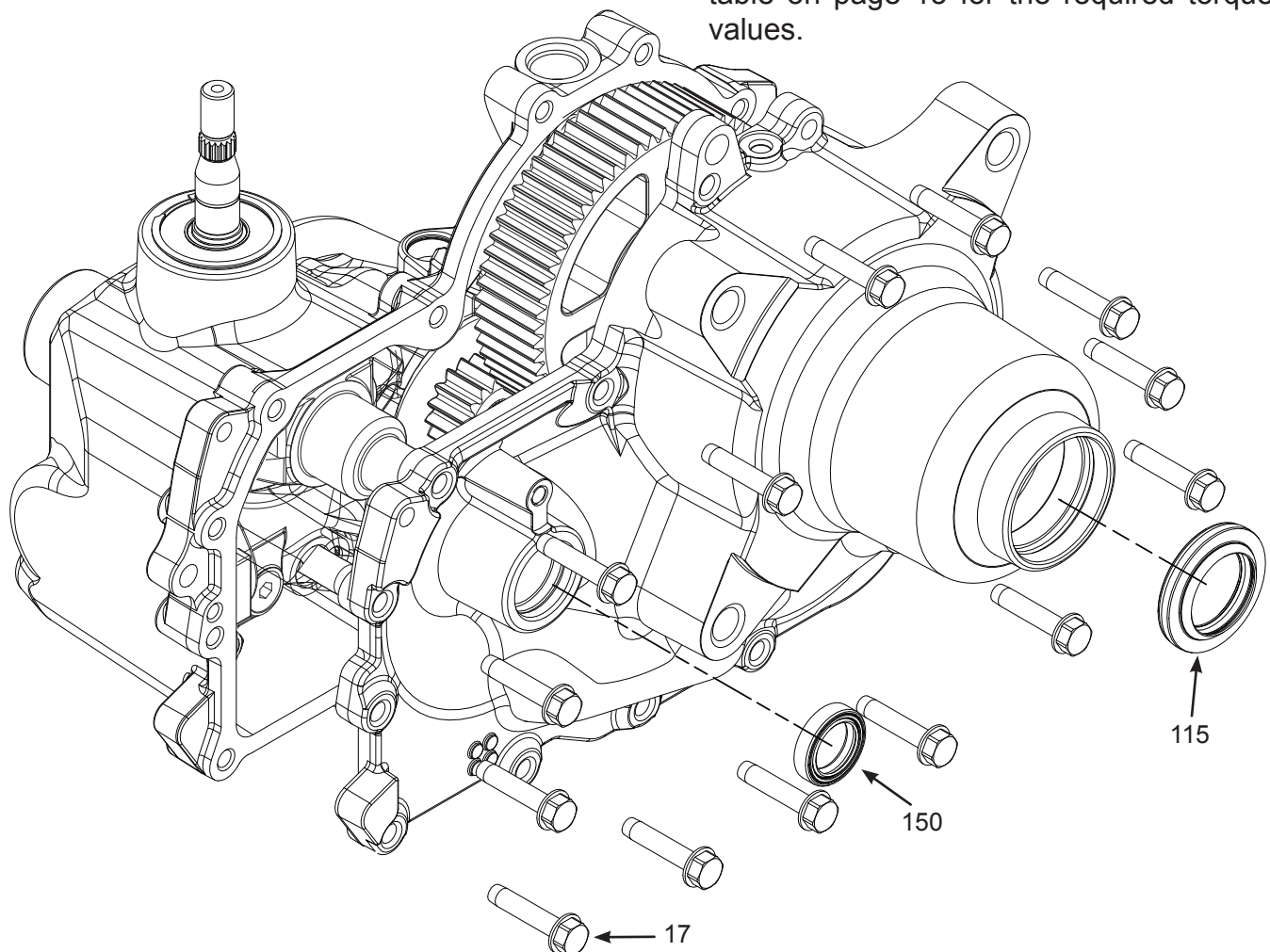

Figure 15, Side Housing

AXLE SHAFT AND PLANETARY GEAR SET

Refer to Figure 16

Disassembly

1. Remove all external items previously discussed in their recommended order.
2. Remove the axle bearing (110) and washer (113).
3. Remove the axle shaft (112) and bull gear (73) assembly.
4. Remove the retaining ring (111). Remove bull gear (73) from axle shaft (112).
5. Remove the bearing (114).

Inspection

1. Inspect all items of the planetary gear set for wear and or damage.

Assembly

1. Reassemble all parts in the reverse order of disassembly.

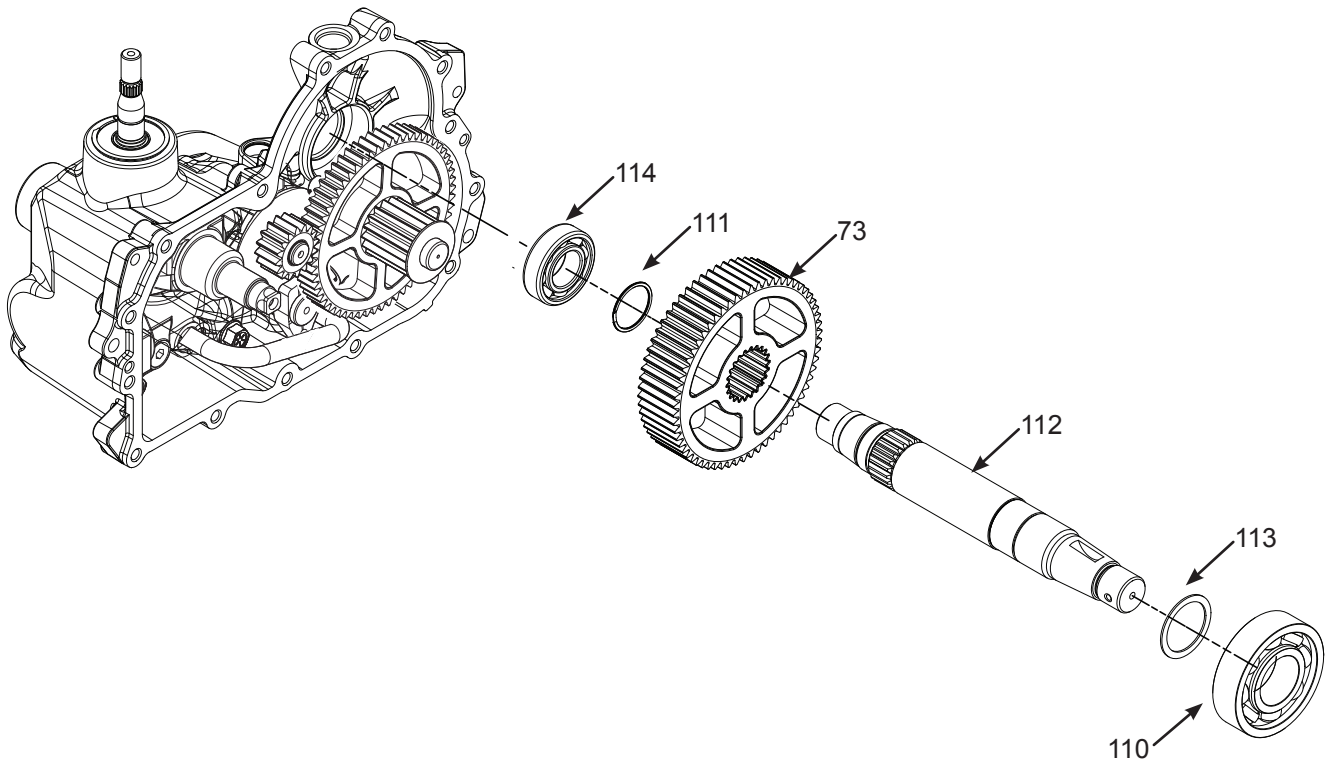

Figure 16, Planetary Gear Set

REDUCTION GEARS

Refer to Figure 17

Disassembly

1. Remove all external items previously discussed in their recommended order.
2. Remove washer (74) and reduction gear set (71) as an assembly and set aside. Remove second washer (74) and jack shaft pin (70).

Inspection

1. Inspect items for wear and or damage. Replace if necessary.

Assembly

1. Reassemble all parts in the reverse order of disassembly.

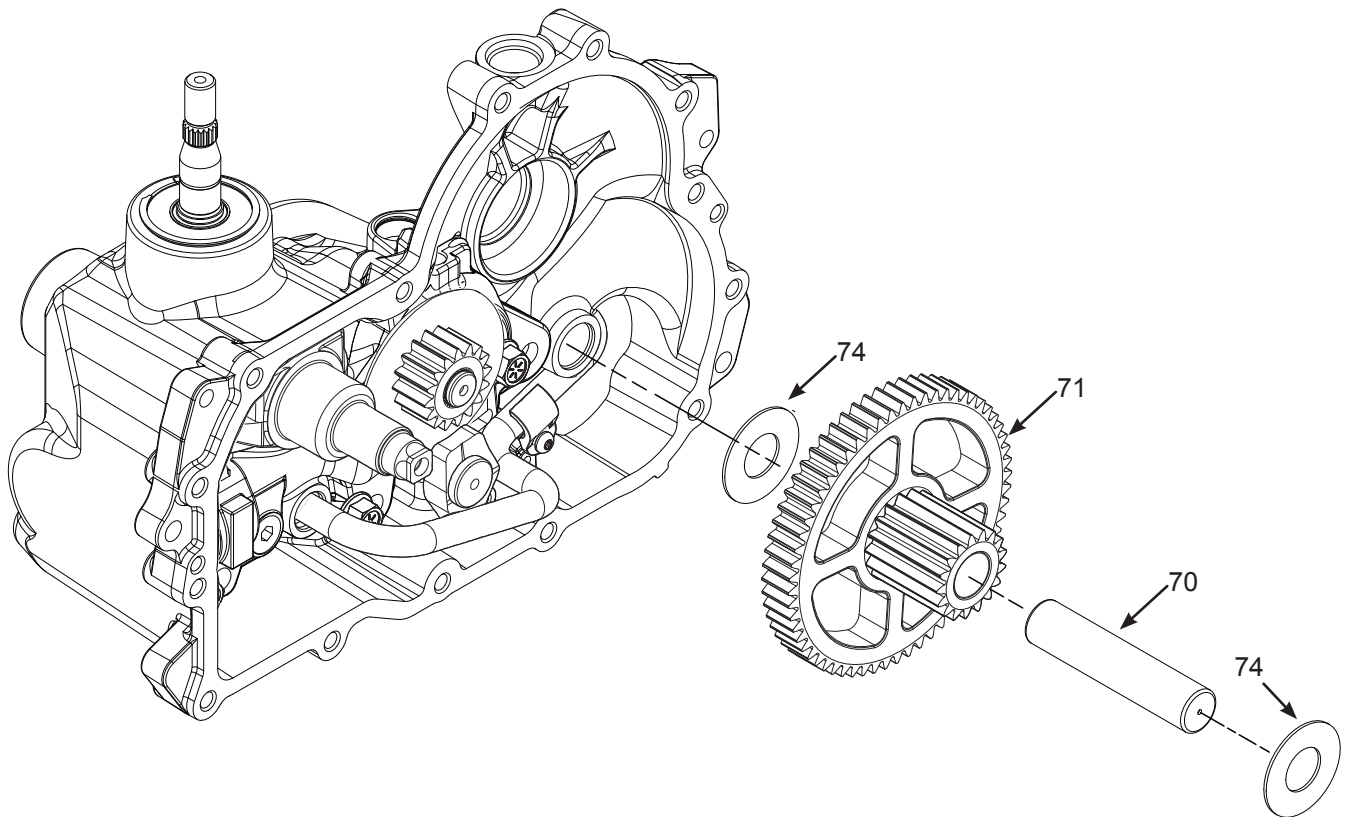

Figure 17, Charge Pump

REMOVE FILTER TUBE

Refer to Figure 18

Disassembly

1. Remove all external items previously discussed in their recommended order.
2. Remove screw (36) and oil tube retainer (104).
3. Remove the oil tube (103).
4. Remove the grommet (105).

Inspection

1. Inspect items for wear and or damage. Replace if necessary.

Assembly

1. Reassemble all parts in the reverse order of disassembly.

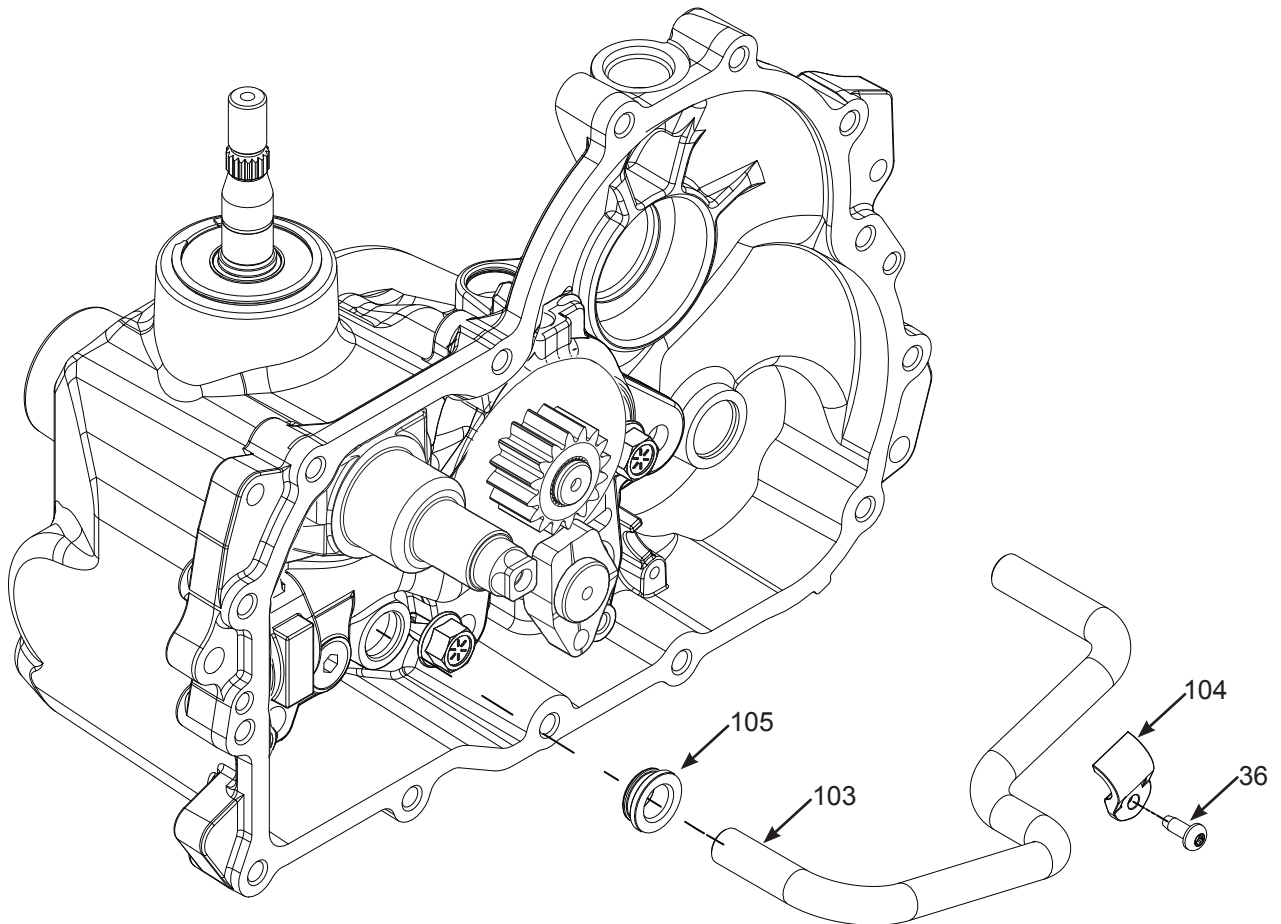

Figure 18, Filter Tube

INPUT SHAFT

Refer to Figure 18

Disassembly

1. Remove all external items previously discussed in their recommended order.
2. Remove the retaining ring (66) and discard.
3. Remove the lip seal (55) and discard.
4. Remove the washer (64).
5. Remove the pump shaft (61) with pressed on bearing.

NOTE: Remove the bearing from pump shaft only if worn or damaged.

5. Remove the wire ring retainer (63) and discard. Remove the bearing (62) from the pump shaft (61a).

Inspection

1. Inspect the bearing and input shaft for wear or damage. Inspect the splines on the shaft for possible damage. Replace if necessary.

Assembly

1. Reassemble all parts in the reverse order of disassembly.
2. Install the input shaft assembly into the main housing.
3. Install the washer (73).
4. Install the new lip seal (74) and new retaining ring (75).

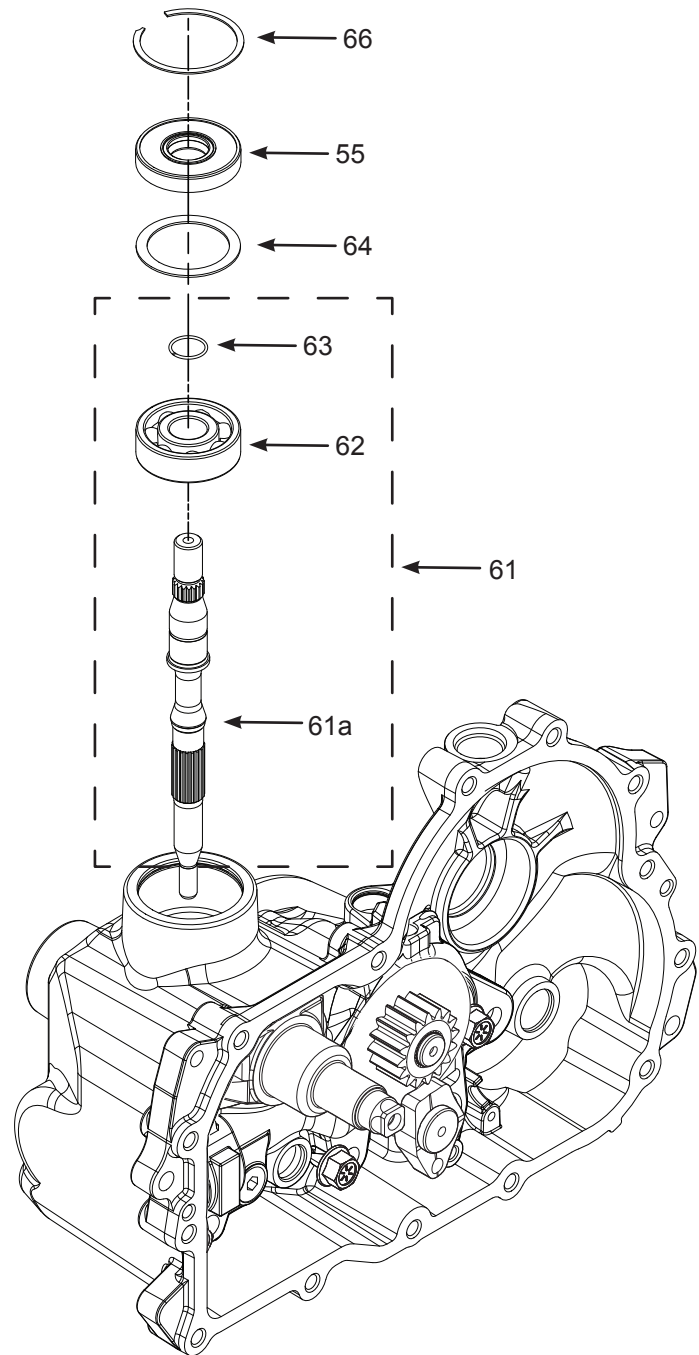

Figure 18, Input Shaft

SWASHPLATE

Refer to Figures 19, 20

Disassembly

1. Remove all external items previously discussed in their recommended order.
2. Remove the swashplate (40), thrust bearing (45), and pump block (49).

Inspection

1. Inspect the races of the thrust bearing (45) for wear or damage.
2. Inspect the pistons and washers of the pump block assembly for scratches and or wear. Replace the pump block assembly if necessary.
3. Inspect for scratches on the machined surfaces of the swashplate (40).
4. Inspect the pump cylinder block (49). See page 31 for more information on inspecting the cylinder block.

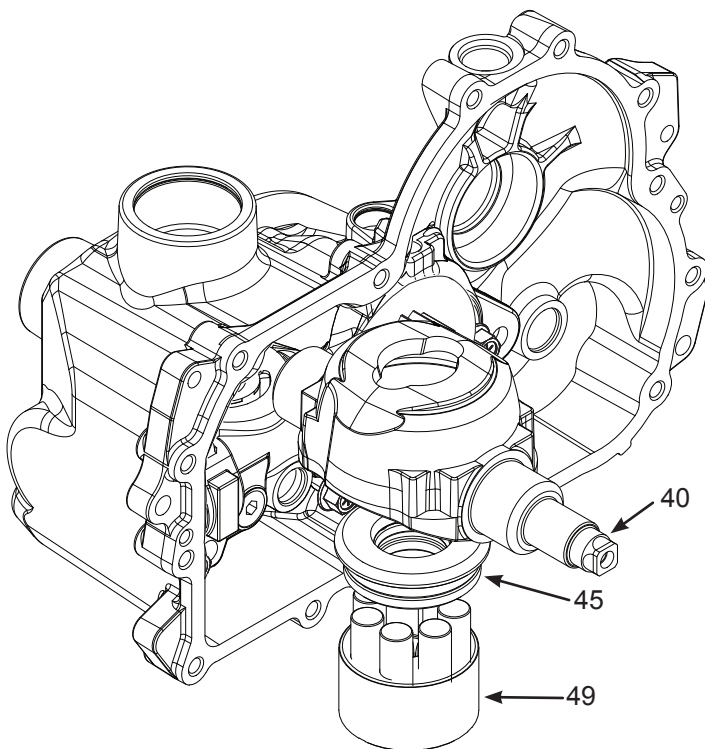

Figure 19, Swashplate

Assembly

1. Reassemble all parts in the reverse order of disassembly.
2. Apply a light coating of oil to all running surfaces.
3. Reassemble the items of the pump block assembly. **Place the thrust bearing assembly (85) so the thick race contacts the pump block pistons.**
4. Realign the swashplate and pump block assembly with the center section.

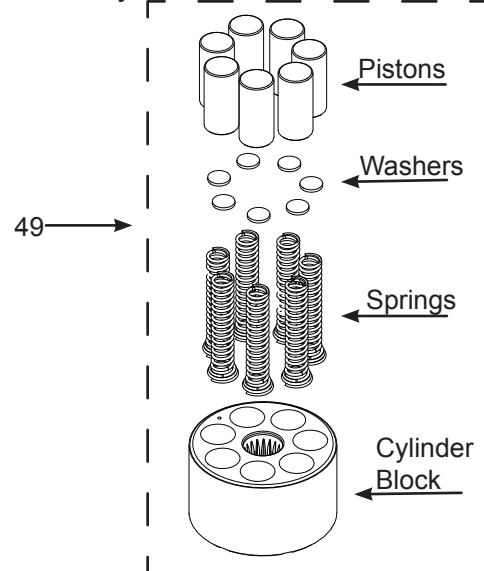

Figure 20, Pump Block Assembly

CENTER SECTION

Refer to Figure 21, and 22

Disassembly

1. Remove all external items previously discussed in their recommended order.
2. Remove the center section bolts (18) and (19).

Inspection

1. Inspect for surface wear damage.

Assembly

1. Reassemble all parts in the reverse order of disassembly.
2. When tightening the fasteners, refer to the table on page 15 for the required torque values. See figure 22 for order of bolt installation.

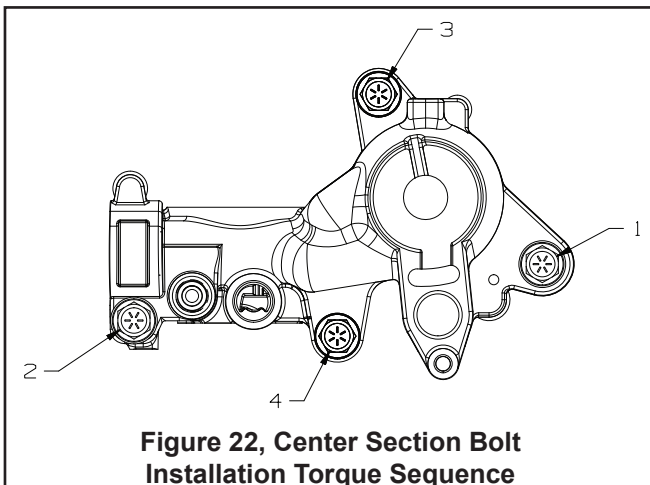
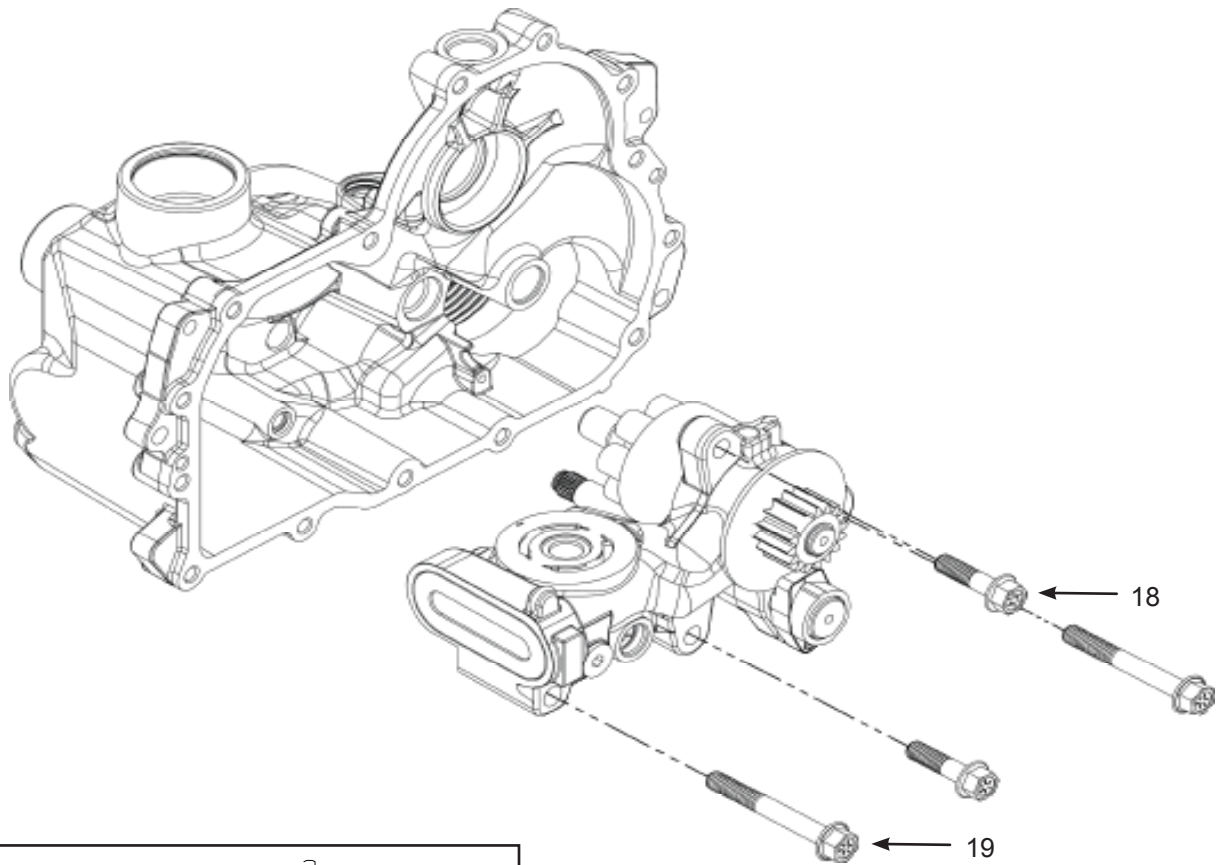

Figure 21, Center Section

Figure 22, Center Section Bolt Installation Torque Sequence

MOTOR SHAFT ASSEMBLY

Refer to Figures 23, 24

Disassembly

1. Remove all external items previously discussed in their recommended order.
2. Remove retaining ring (30), the spring (31), motor block (23), and the bypass plate (125).
3. Remove the retaining ring (34), gear (33), brake rotor (82), washer (74) and motor shaft (22).

Inspection

1. Inspect for scratches and or damage to the brake rotor (82).
2. Inspect the bypass plate (125) for excessive wear.
3. Inspect the gear (33) for wear or damage.
4. Inspect the pump cylinder block (23) and center section (20). See page 31 for more information on inspecting the cylinder block.

Assembly

1. Reassemble all parts in the reverse order of disassembly.

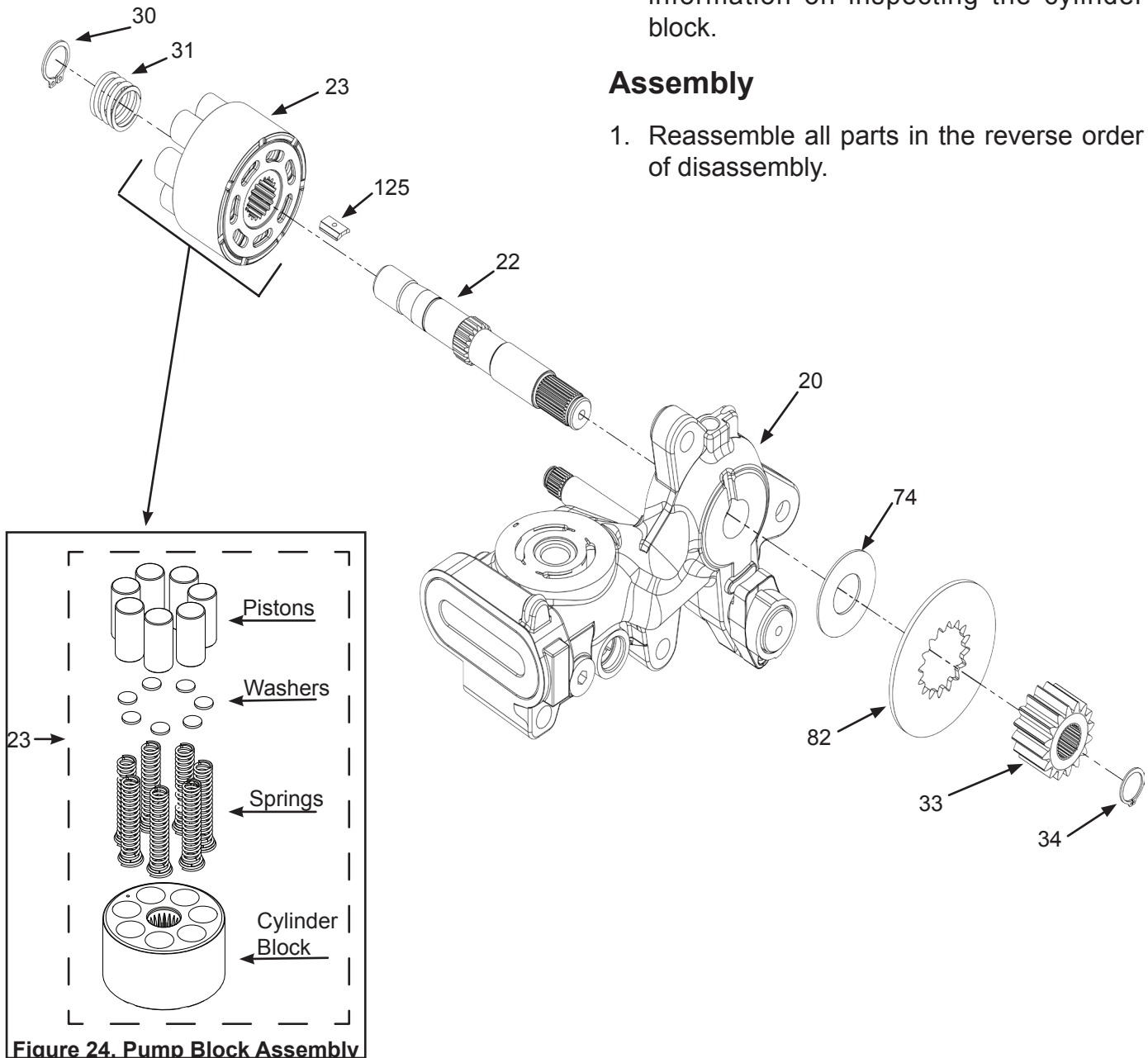

Figure 24, Pump Block Assembly

BRAKE ASSEMBLY

Refer to Figure 25

Disassembly

NOTE: If the brake is working properly and the brake components are not damaged, **do not remove the brake assembly.**

1. Remove the brake shaft nut (87) and washer (86).
2. Remove the brake shaft (85), the splined cam (84), the puck cam (83) and brake puck (81).

Inspection

1. Inspect the puck (81) for excessive wear.

Assembly

1. Reassemble all parts in the reverse order of disassembly.

NOTE: The brake components are only available in the center section kit. When a new center section kit is ordered it will come with the brake components installed.

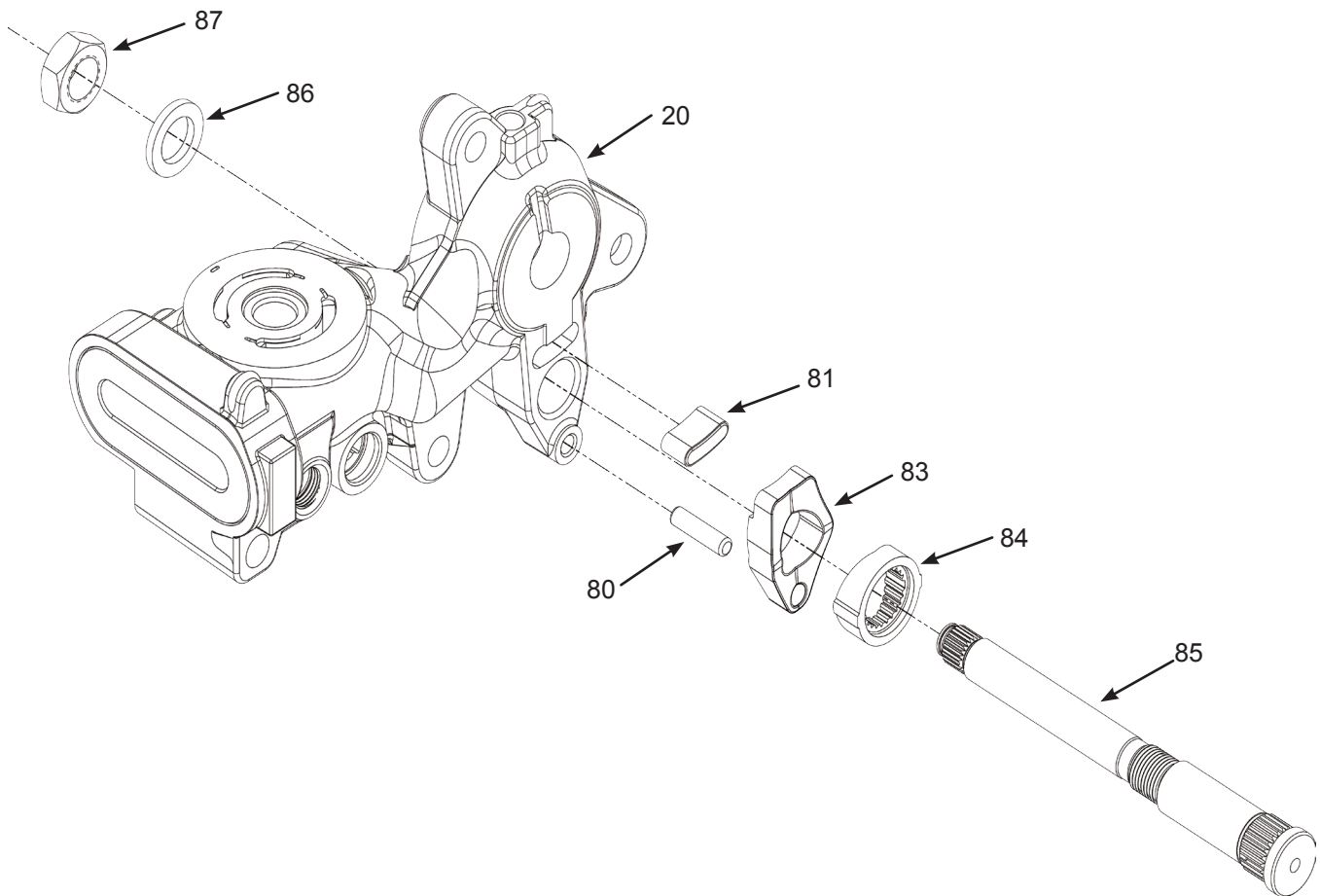

Figure 25, Brake Assembly

THRUST BEARING

Refer to Figure 26

Disassembly

1. Remove all external items previously discussed in their recommended order.
2. Remove the thrust bearing.

Inspection

1. Inspect the races of the thrust bearing (27) for wear or damage.

Assembly

1. Reassemble all parts in the reverse order of disassembly.
2. **Place the thrust bearing assembly (27) so the thick race contacts the motor block pistons.**

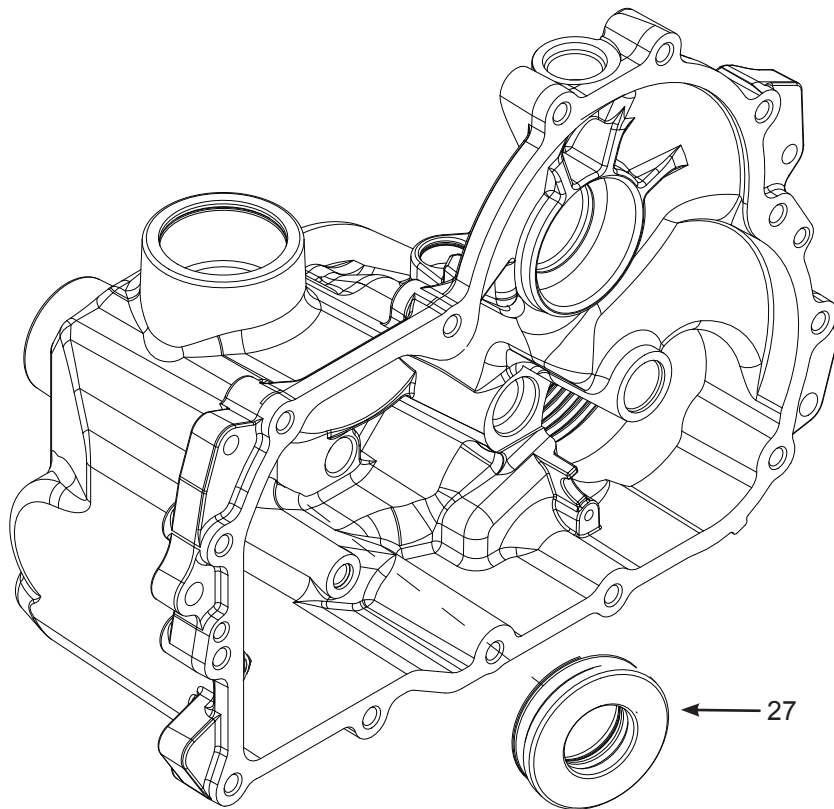

Figure 26, Thrust Bearing

INSPECTING THE HYDRAULIC COMPONENTS

Refer to Figure 27-29

Inspect the running surfaces on the pump block, motor block, and both running faces on the center section. Note: The pump face on the center section has machined groves as seen in Figure 28. These are not defects.

These “sealing” surfaces should be smooth in appearance without scratches, scoring, nicks or abrasions.

Drag a fingernail across the surface to detect uneven wear or scratches with may not be visible paying close attention to the areas circled in gray in the figures below.

If any wear that can be felt with a fingernail is detected replace the component.

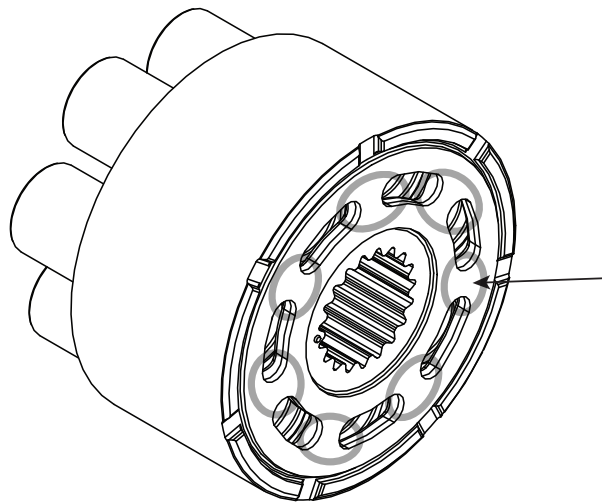

Figure 27, Cylinder Block Running Surface

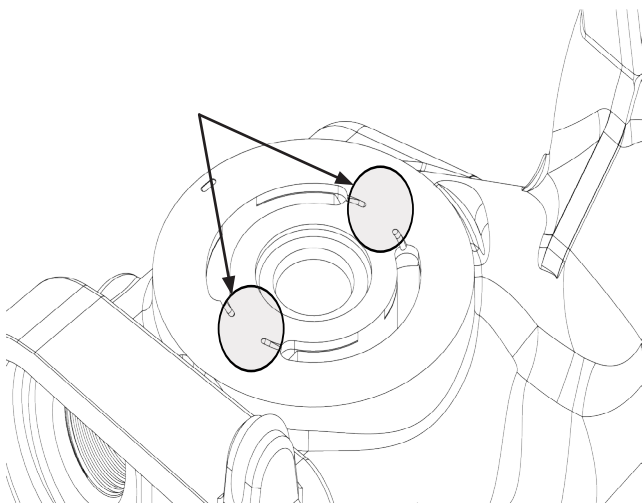

Figure 28, Pump Block Running Surface

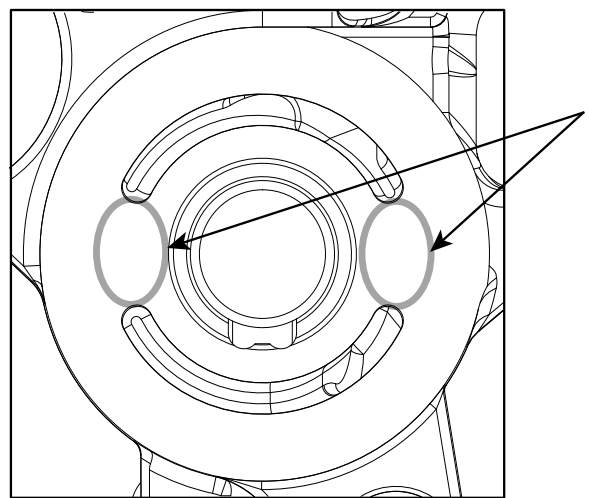

Figure 29, Motor Block Running Surface

SHOCK VALVES, CHARGE RELIEF, CHARGE PUMP, MAGNET

Refer to Figure 30

Disassembly

1. Remove all items previously discussed, in their recommended order.
2. Pry off the charge galley cap (15).

NOTE: Mark orientation of the shock valves before removing.

3. Remove the shock valve assembly (10) and disassemble. Remove the shock valve seats (13), shock valves (10/11), the springs (12) and the check spring retainers (30).
5. Remove the charge pressure relief plug (54), the spring (55) and the ball (56).
6. Remove charge cover bolts (51), charge cover (53), o-ring (52), and gerotor (57).

Inspection

1. Inspect the all items for wear or damage. Replace if necessary.
2. Clean off the magnet (35). Only disassemble if damaged.

Assembly

1. Assemble items in reverse order of disassembly.
1. The lip on the center portion of the gerotor (57) will fit inside the center section.
2. When tightening components refer to the table on page 15 for the required torque values.

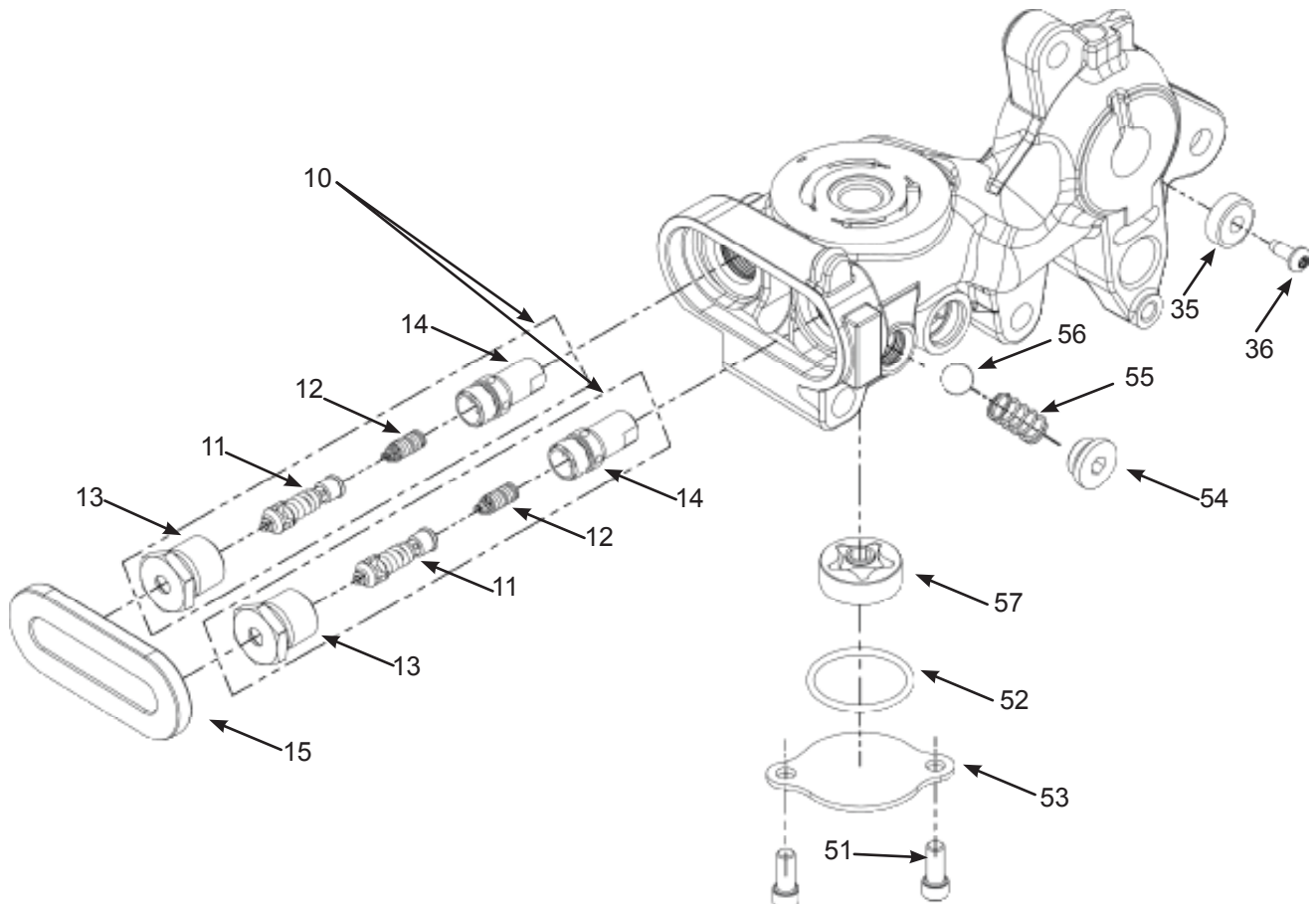

Figure 30, Charge Galley Assembly and Magnet

ASSEMBLY AFTER A COMPLETE TEARDOWN

If the unit has been torn down completely, the following summary identifies the assembly procedures necessary to completely assemble the unit. Each assembly procedure is located by a page reference.

The part reference numbers provided in each assembly procedure are keyed to the individual exploded views, and are also keyed to the complete unit exploded view on page 38.

1. Assemble the center section components (magnet, charge pump, charge relief, shock valves, and new galley cap). *See page 33 for details. See page 15 for the required torque steps.*
2. Place the motor thrust bearing in the housing. *See page 31 for details.*
3. Assemble the brake assembly (if removed), *See page 30 for details. See page 15 for the required torque steps.*
4. Install motor shaft, motor block component, and brake rotor components. *See page 29 for details.*
5. Install the complete center section assembly in to the housing. *See page 28 for details. See page 15 for the required torque steps.*
6. Install swashplate, thrust bearing, and pump block. *See page 27 for details.*
7. Install input shaft, washer, seal, and retaining ring. *See page 26 for details.*
8. Install the grommet, oil tube, retainer, and screw. *See page 25 for details.*
9. Install washer, jack shaft pin, gear set, and second washer into housing. *See page 24 for details.*
10. Install bearing into housing. Assemble bull gear and retaining ring onto the axle shaft. Install in the bearing previously placed in the housing. Install washer and second bearing. *See page 23 for details.*
11. Install sealant (see page 35 for details), side housing, bolts (order sequence shown on page 35), and seals. *See page 22 for details. See page 15 for the required torque steps.*

NOTE: *Prior to applying the new sealant, the old sealant must be removed from all surfaces.*

A small consistent bead (approximately 1/16 – 1/8 inch) of the sealant around the housing face will be sufficient. Use sparingly.

The illustration on page 35 indicates the correct sealant path.

12. Install seal, bypass rod with clip retaining ring, and retaining ring into housing. *See page 21 for details.*
13. Install the seal, bushing, spring, brake arm, and retaining ring. *See page 20 for details.*
14. Install filter, o-ring, and filter cover. *See page 19 for details.*
15. Control arm assembly installation: Install the spacer onto the short stud. Install the control arm onto the trunnion shaft. Secure the control arm to the trunnion shaft with Torx Head cap-screw. Install the washer and nut. *See page 18 for details. See page 15 for the required torque steps.*

— OR —

RTN assembly installation: Install the spacer, neutral arm, washer, and socket head cap-screw. Place the control arm on the trunnion shaft. Install the RTN assembly, washer onto the trunnion shaft and secure with Torx head capscrew. Install the spring on the RTN assembly. *See page 17 for details. See page 15 for the required torque steps.*

NOTE: *Return to Neutral Setting can be found on page 12.*

16. Install the axle seal and retaining ring into the side cover. Place the axle shaft key into the keyway on the axle. Slide the hub onto the axle and secure with the castle nut. *See page 16 for details. See page 15 for the required torque steps.*
17. Install pulley hub, pulley, fan, and locknut. *See page 16 for details. See page 15 for the required torque steps.*
18. Perform the purge procedures listed on page 11.

SEALANT APPLICATION

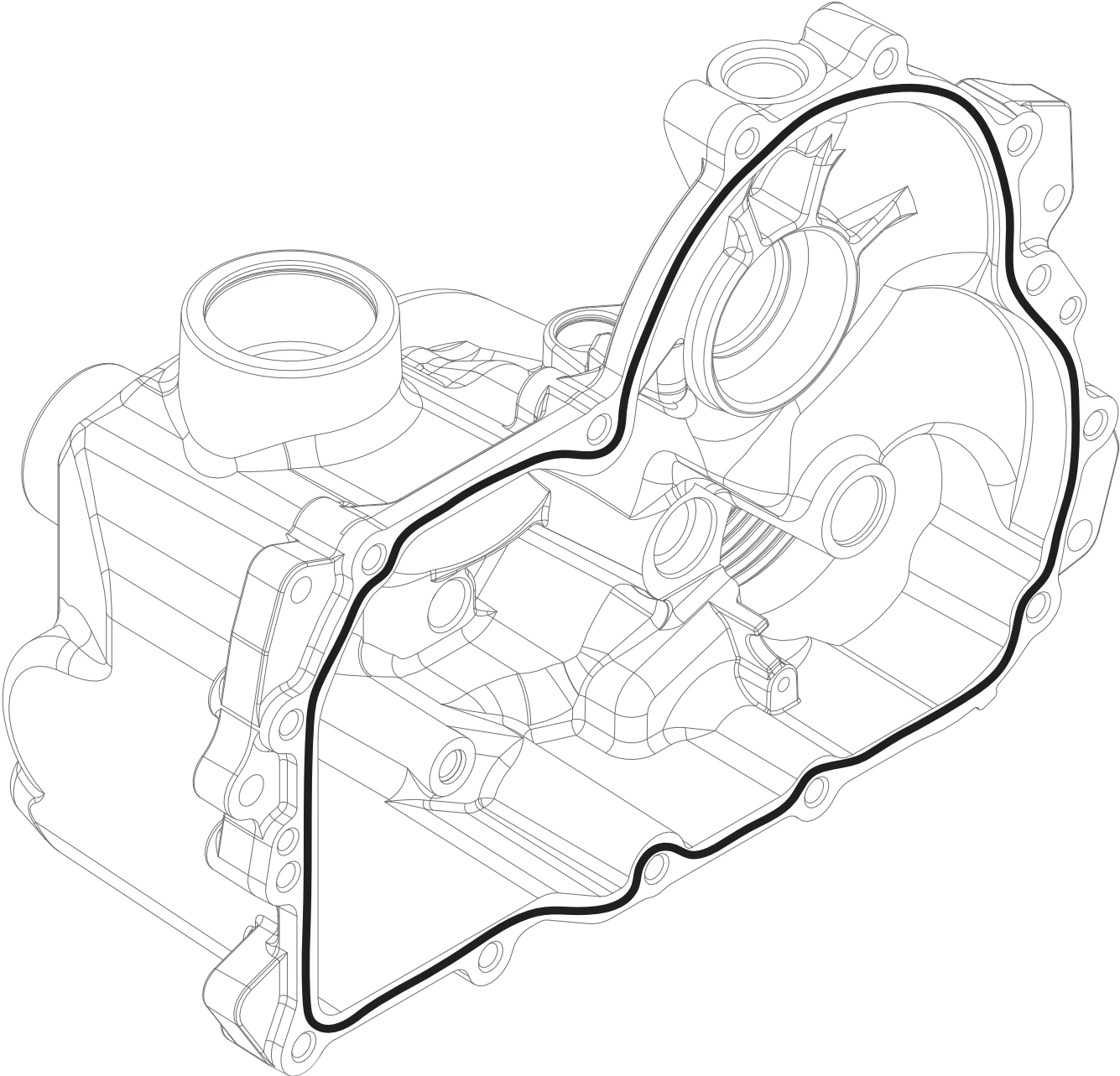

Figure 31, Sealant Application Diagram

SIDE HOUSING – SCREW TIGHTENING SEQUENCE

Starting with the number “1” screw location, tighten sequentially through to “14.”

Torque each screw to 230 – 290 lb-in (25.9 – 32.7 Nm).

NOTE: As a general rule, use the low end of the torque specification.

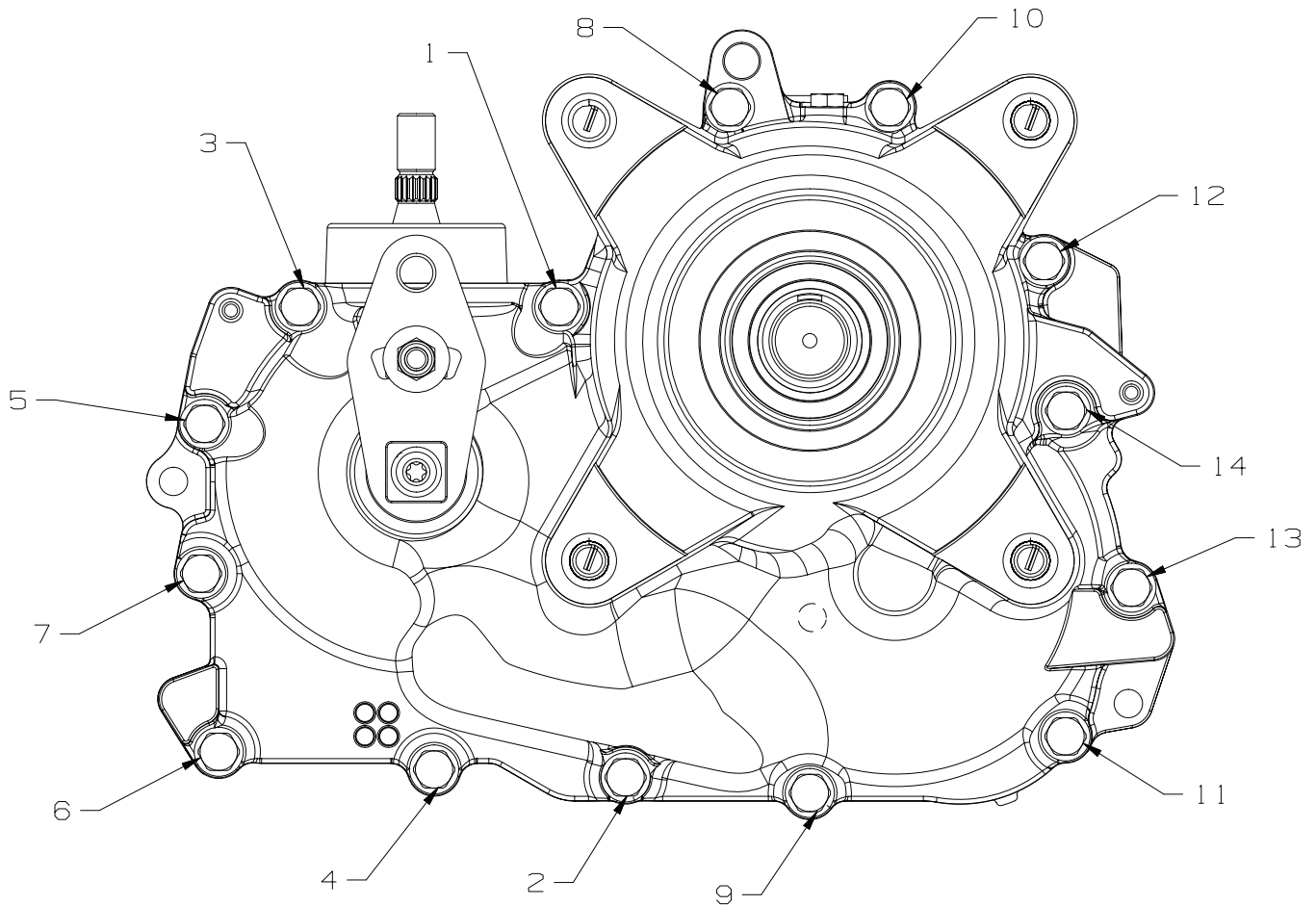

Figure 32, Screw tightening sequence

CASTLE NUT (113) ALTERNATE TORQUE METHOD

NOTE: The ideal method for installing a new hub and nut is utilizing a torque wrench capable of 275 ft-lbs. If a 275 ft-lbs torque wrench is not available please use the alternative procedure outlined in this document. All parts need to be clean and free of lubrication.

Tools:

1. Air Compressor and Air Impact Wrench or Electric Impact Wrench (**REMOVAL ONLY**)
2. 1 7/16" Socket
3. Socket Extension
4. Torque Wrench (Must be capable of achieving 50 ft-lbs)
5. Paint Pen or visible marker.
6. Flash Light

Procedure:

1. Engage machine parking brake.
2. Remove nut cover.
3. Remove existing nut.
4. Install new nut to 50 ft-lbs
5. Mark a point on the new nut and hub per Figure 28. (Point A)
6. Measure 2 nut flats or 120° per Figure 28 and mark hub. (Point B)
7. Turn nut clockwise until mark "A" lines up with mark "B". (Figure 29)
8. Continue turning nut clockwise until the slot lines up with the cross hold of the axle shaft.
9. Install cotter pin.
10. Reinstall nut cover.

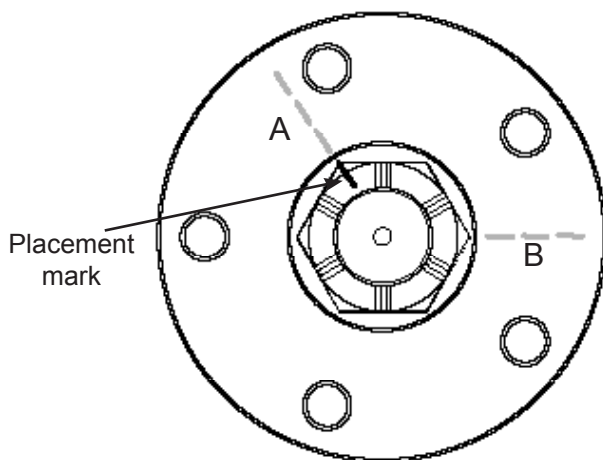

Figure 33

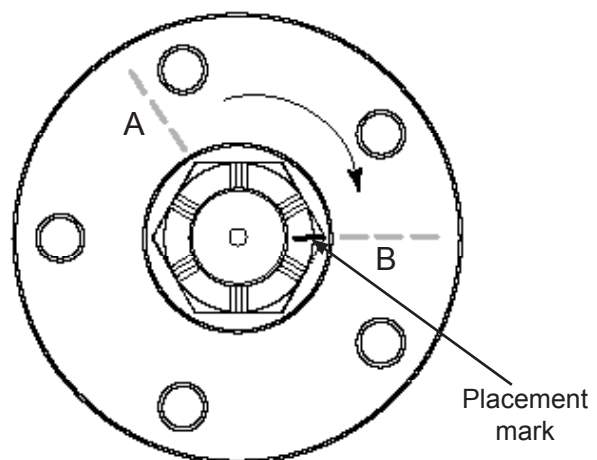
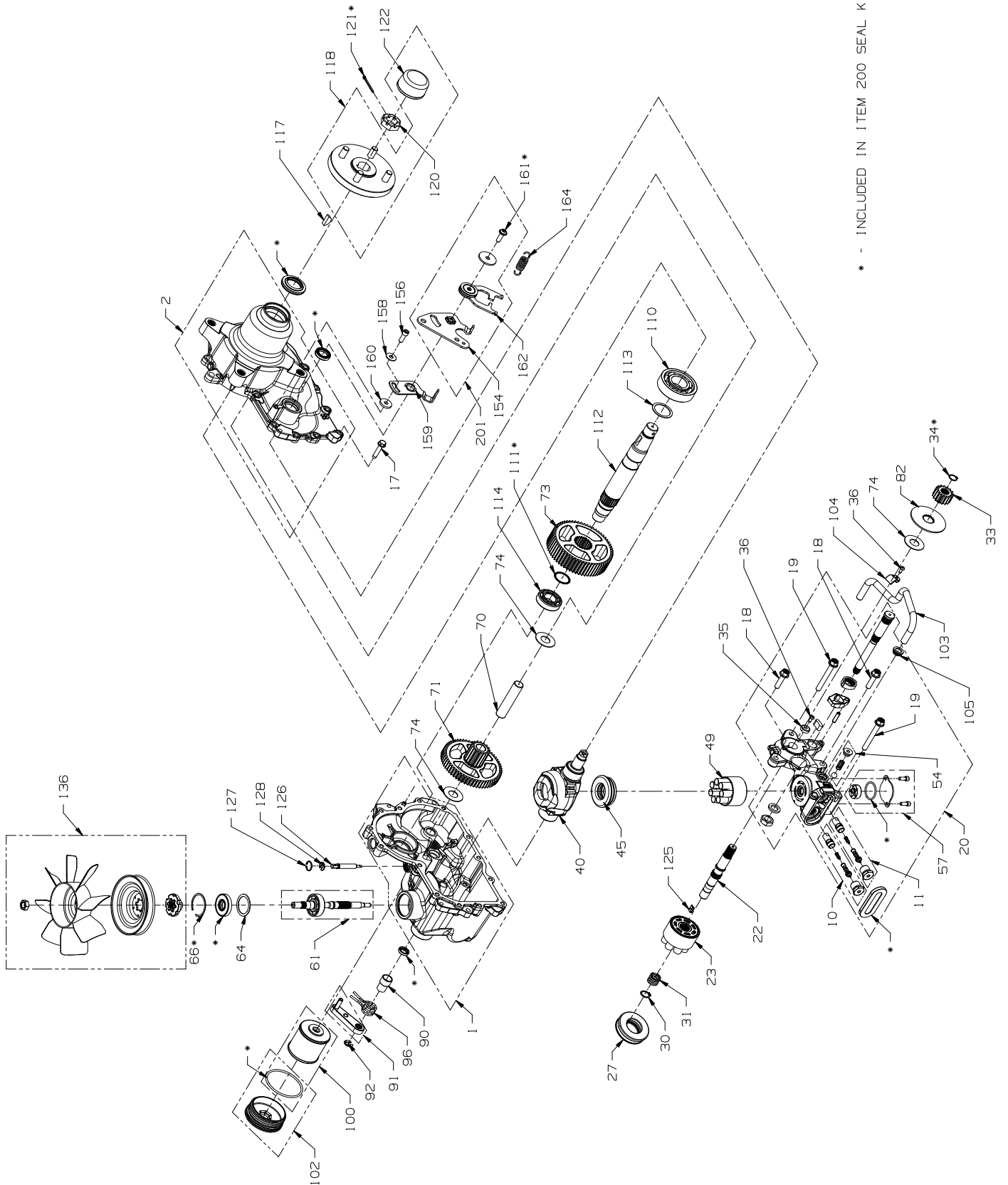

Figure 34

Figure 33 / Figure 34, Alternate Torque Method

ZT-4400 EXPLODED VIEW



* - INCLUDED IN ITEM 200 SEAL KIT

ZT-4400 TRANSAXLE PARTS LIST

1	Housing, Main	96	Spring, Brake Return
2	Housing, Side	100	Kit, Filter
10	Kit, Shock Valve	102	Kit, Filter Plug
11	Kit, Shock Valve	103	Tube, Filter
17	Screw, Housing	104	Clamp, Tube, Filer
18	Screw, Hex Flange 3/8-16 X 1.5	105	Grommet
19	Screw, Hex Flange 3/8-16 X 3.0	110	Bearing, Ball, Axle Inboard
20	Kit, Center Section	111	Ring, Retaining, External, Spring
22	Shaft, Motor	112	Shaft, Axle
23	Kit, Cylinder Block	113	Washer, Axle Shaft Bearing
27	Bearing, Thrust, Motor	114	Bearing, Call, Outboard
30	Ring, Retaining	117	Key, Shaft, Axle
31	Block Spring	118	Kit, Hub 4 Bolt
33	Gear, 16T	120	Nut, Hex 1-20 Slotted
34	Ring, Retaining, Motor Shaft, Pinion	121	Pin, Cotter
35	Magnet	122	Cap, Axle
36	Bolt, Self-Tapping	125	Plate, Bypass
40	Swashplate, Machined	126	Bypass Rod
45	Bearing, Thrust, Pump	127	Bypass Retaining Ring 2
49	Kit, Cylinder Block	128	Bypass Retaining Ring 1
54	Kit, Charge Relief	136	Kit, Fan/Pulley
57	Kit, Charge Pump	154	Arm, Control
61	Kit, Input Shaft	156	TWHCS (Patch)
64	Input, Spacer	158	Spacer
66	Ring, Retaining, Internal, Input	159	Arm, Neutral
70	Jackshaft	160	Washer
71	Kit, Gears	161	SHCS (Patch)
73	Gear, 62T	162	Assembly, RTN, Uni-Directional
74	Washer, Jackshaft	164	Spring, Extension
82	Rotor, Brake	201	Kit, RTN
90	Spacer, Spring		
91	Kit, Brake		
92	Ring, Retaining, Brake Handle		

GLOSSARY OF TERMS

Axial Piston: Type of design for hydraulic motors and pumps in which the pistons are arranged parallel with the spindle (input or output shaft).

Bypass Valve: A valve whose primary function is to open a path for the fluid to bypass the motor or pump. Also referred to occasionally as the freewheel valve or dump valve.

Case Drain Line (Return Line): A line returning fluid from the component housing to the reservoir.

Cavitation: A concentrated gaseous condition within the fluid causing the rapid implosion of a gaseous bubble.

Center Section: A device which acts as the valve body and manifold of the transmission.

Charge Pump: A device which supplies replenishing fluid to the fluid power system (closed loop).

Charge Pressure: The pressure at which replenishing fluid is forced into a fluid power system.

Charge Relief Valve: A pressure control valve whose primary function is to limit pressure in the charge circuit.

Check Valve: A valve whose primary function is to restrict flow in one direction.

Closed Loop: A sealed and uninterrupted circulating path for fluid flow from the pump to the motor and back.

Decay Rate: The ratio of pressure decay over time.

End Cap: See "Center Section."

Entrained Air: A mechanically generated mixture of air bubbles having a tendency to separate from the liquid phase.

Gerotor: A formed rotor set operating about an eccentric that provides a fixed displacement for pumps or motors.

Hydraulic Motor: A device which converts hydraulic fluid power into mechanical force and motion by transfer of flow under pressure.

Hydraulic Pump: A device which converts mechanical force and motion into hydraulic fluid power by producing flow.

Hydrostatic Pump: See "Hydraulic Pump."

Hydrostatic Transaxle: A multi component assembly including a gear case and a hydrostatic transmission.

Hydrostatic Transmission: The combination of a hydraulic pump and motor in one housing to form a device for the control and transfer of power.

Inlet Line: A supply line to the pump.

Integrated Zero-Turn Transaxle: The combination of a hydrostatic transmission and gear case in one housing to form a complete transaxle.

Manifold: A conductor which provides multiple connection ports.

Neutral: Typically described as a condition in which fluid flow and system pressure is below that which is required to turn the output shaft of the motor.

Pressure Decay: A falling pressure.

Priming: The filling of the charge circuit and closed loop of the fluid power system during start up, frequently achieved by pressurizing the fluid in the inlet line.

Purging: The act of replacing air with fluid in a fluid power system by forcing fluid into all of the components and allowing the air a path of escape.

Rated Flow: The maximum flow that the power supply system is capable of maintaining at a specific operating pressure.

Scoring: Scratches in the direction of motion of mechanical parts caused by abrasive contaminants.

Swash Plate: A mechanical device used to control the displacement of the pump pistons in a fluid power system.

System Charge Check Valve: A valve controlling the replenishing flow of fluid from a charge circuit to the closed loop in a fluid power system.

System Pressure: The pressure which overcomes the total resistance in a system, including all efficiency losses.

Valve: A device which controls fluid flow direction, pressure, or flow rate.

Variable Displacement Pump: A pump in which the displacement per revolution can be varied.

Volumetric Displacement: The volume for one revolution.

NOTES



© 2015 HYDRO-GEAR
Printed in U.S.A.
BLN-0081_P5

