



# 17–44HXL Indy Special Edition

## Wheel Horse® Lawn Tractor

Model No. 71233–21000001 and Up

### Parts Catalog

---

#### Ordering Replacement Parts

To order replacement parts, please supply: the part number, the quantity, and the description of each part desired.

#### Understanding Reference Numbers

Each identified part in an illustration has a reference number. The reference number for a part also appears in the parts list, along with other information about the part.

This catalog uses two special reference number formats, one to indicate parts in a service assembly and another to indicate the quantity of a given part in an illustration.

#### Service Assembly Reference Numbers

Parts in service assemblies have reference numbers in the form **a:b**. The **a** represents the reference number of the entire service assembly and the **b** represents a sequential number unique to each part within the service assembly.

For example, a wheel assembly might be identified by reference number **6**, the tire by **6:1**, the valve by **6:2**, and the wheel by **6:3**. When you order the assembly identified by reference number **6**, you receive all parts identified by reference numbers **6:1**, **6:2**, and **6:3**. However, you may also order any part individually.

Reference numbers of this type appear in illustrations and in part lists.

#### Reference Numbers Indicating Quantity

In an illustration, if a reference number indicates more than one part, the reference number has the form **nX y**. The **n** represents the quantity of the part, the **X** is the multiplication symbol, and the **y** represents the reference number.

For example, in an illustration, the reference number **2X 37** means that two of the parts identified by reference number **37** are indicated.

## Contents

Description	Page	Description	Page
Frame and Body Assembly .....	3	Crankcase Assembly Briggs and Stratton Model 312777–0128–E1 .....	21
Hood and Tower Assembly .....	4	Carburetor Assembly Briggs and Stratton Model 312777–0128–E1 .....	22
Rear Body and Seat Assembly .....	5	Governor Assembly Briggs and Stratton Model 312777–0128–E1 .....	23
Steering Assembly .....	6	Oil Filter, Tube, and Pump Assembly Briggs and Stratton Model 312777–0128–E1 .....	24
Steering Assembly .....	7	Air Cleaner Assembly Briggs and Stratton Model 312777–0128–E1 .....	25
Engine System Assembly .....	8	Blower Housing Assembly Briggs and Stratton Model 312777–0128–E1 .....	26
Traction Brake Assembly .....	9	Starter Assembly Briggs and Stratton Model 312777–0128–E1 .....	27
Wheel and Tire Assembly .....	10	Carburetor Overhaul Kit Assembly Briggs and Stratton Model 312777–0128–E1 .....	28
Hydro Transaxle Assembly .....	11	Maintenance .....	29–31
Hydro Transaxle Controls and NMIR Assembly .	12		
Height of Cut Assembly .....	13		
Electrical Assembly .....	14		
Electrical Schematic .....	15		
Housing and Bearing Assembly .....	16		
Gear Assembly .....	17		
Axle Assembly .....	18		
Cylinder Assembly Briggs and Stratton Model 312777–0128–E1 .....	19		
Cylinder Head Assembly Briggs and Stratton Model 312777–0128–E1 .....	20		

## Part Description Abbreviations

Part descriptions in this catalog may include the following abbreviations.

Abbreviation	Meaning	Abbreviation	Meaning
AR .....	as required	INC .....	incorporated
ASM .....	assembly	LH .....	left hand
CARR .....	carriage	NI .....	nylon insert
DEG .....	degrees	PPH .....	Phillips pan head
FH .....	flat head	PTH .....	Phillips truss head
GA .....	gauge	PTO .....	power take off
HF .....	hex flange	RH .....	right hand
HH .....	hex head	SFH .....	slotted fillister head
HHF .....	hex head flange	SHH .....	slotted hex head
HLH .....	hex lag head	SQH .....	square head
HJ .....	hex jam	SHWH .....	slotted hex washer head
HOC .....	height-of-cut	SPH .....	slotted pan head
HS .....	hex socket	SRH .....	slotted round head
HSBH .....	hex socket button head	STD .....	standard
HSFH .....	hex socket flat head	TAP .....	self tapping
HSH .....	hex socket head	TTH .....	Torx truss head
HWH .....	hex washer head	WH .....	wing head
HWHTF .....	hex washer head thread forming		



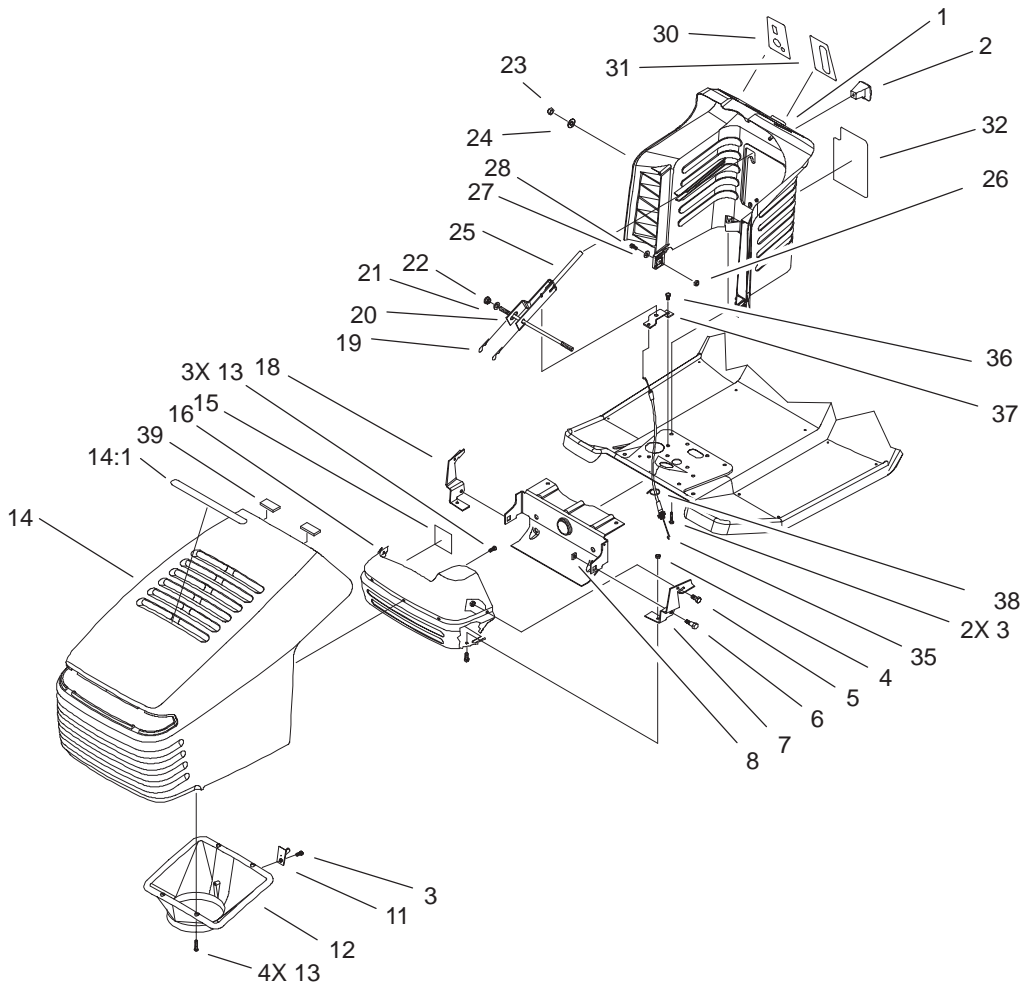

Sheet No.:3

## Hood and Tower Assembly

Ref. No.	Part No.	Qty.	Description
1	99-1947	1	Tower-Steering
2	94-5565	1	Knob - Shift
3	46-8091	3	Screw-HWH
4	3296-42	4	Nut-Lock, NI
5	321-2	4	Screw-HH
6	28-0540	2	Bolt-Shoulder
7	88-6050-03	1	Bracket-LH Hinge
8	3290-496	2	Nut-Retainer
11	94-1984	1	Latch - Pin
12	93-3891	1	Duct - Hood Air
13	46-8090	7	Screw-Plastite
14	92-8650	1	Hood-V-Chassis Toro
14:1	92-5748	1	Decal-Air Duct Toro
15	92-5782	3	Tape-Foil
16	93-3864-03	1	Shield - Heat
18	88-6040-03	1	Bracket-RH Hinge
19	3290-307	2	Pin-Hair
20	100-7401	1	Rod-Tower Pivot
21	3256-24	2	Washer-Flat
22	3218-3	2	Nut-Jam
23	100-7402	2	Nut-Cap
24	100-7403	2	Washer-Flat
25	88-5190-03	1	Lever-Deck Engage
26	3296-29	2	Nut-Lock NI
27	3256-23	2	Washer-Flat

Ref. No.	Part No.	Qty.	Description
28	322-3	2	Screw-HH
30	99-8139	1	Decal-Ignition/Lights
31	92-2461	1	Decal - Throttle
32	92-2462	1	Decal - Deck Engage
35	99-6838	1	44 Inch Deck Cable ASM
36	9266714	2	Screw-HWH
37	93-3849	1	Brkt-Upper Cable
38	614249	1	Tie-Strap
39	94-1980	2	Foam - Hood



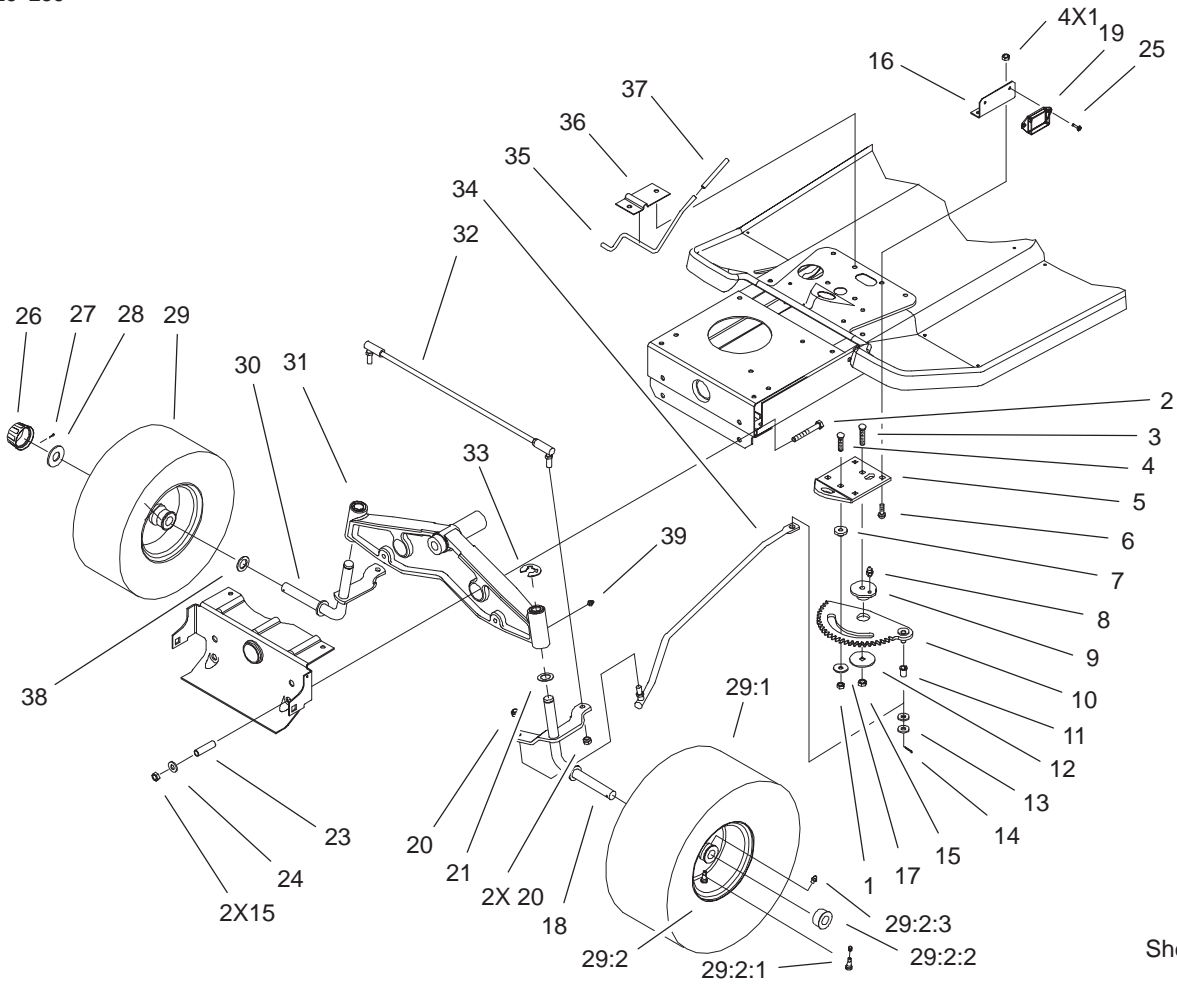

Sheet No.:5

## Steering Assembly

Ref. No.	Part No.	Qty.	Description
1	3296-29	5	Nut-Lock NI
2	323-13	2	Screw-HH
3	3231-4	1	Screw-CARR
4	3230-3	1	Screw-CARR
5	88-5130-03	1	Bracket-Steering Rack
6	3230-2	4	Screw-CARR
7	88-5010	1	Spacer - Steering Rack
8	302-26	1	Zerk
9	88-4670	1	Bushing - Eccentric
10	88-5200	1	Rack-Steering
11	52-2891	1	Bushing-Link, Steering
12	111419	1	Bearing-Washer
13	3256-25	2	Washer-Flat
14	3272-10	1	Pin-Cotter
15	3296-39	3	Nut-Lock, NI
16	99-2956-03	1	Bracket-Module
17	5-4460	1	Washer-Pivot
18	93-3833-03	1	Spindle-LH
19	99-3700	1	Module-Nmir
20	3296-5	3	Nut-Lock NI
21	3-6498	2	Washer-Thrust
23	88-5470	2	Spacer-Front Axle
24	3256-24	2	Washer-Flat

Ref. No.	Part No.	Qty.	Description
25	9266714	2	Screw-HWH
26	61-9780	2	Cap-Hub
27	3272-12	2	Pin-Cotter
28	28-2480	2	Washer
☆29		2	Front Wheel And Tire ASM
29:1	99-2988	1	Tire
29:2	88-4370	1	15 Inch Rim ASM
29:2:1	232-27	1	Stem-Valve
29:2:2	88-4400	2	Bearing - Wheel
29:2:3	302-5	1	Fitting-Grease
*	232-39	1	Tube
30	92-7889-03	1	Spindle-RH
31	99-2955-03	1	Axle-Front
32	93-3873	1	Tie Rod ASM
33	32151-48	2	E-Ring
34	93-3840	1	Link-Drag
35	88-5510	1	Rod-Parking Brake
36	88-5520-03	1	Bracket-Parking Brake
37	88-0890	1	Grip-Bag Handle
38	3-6498	4	Washer-Thrust
39	302-5	2	Fitting-Grease

☆ Not serviced  
\* Not illustrated



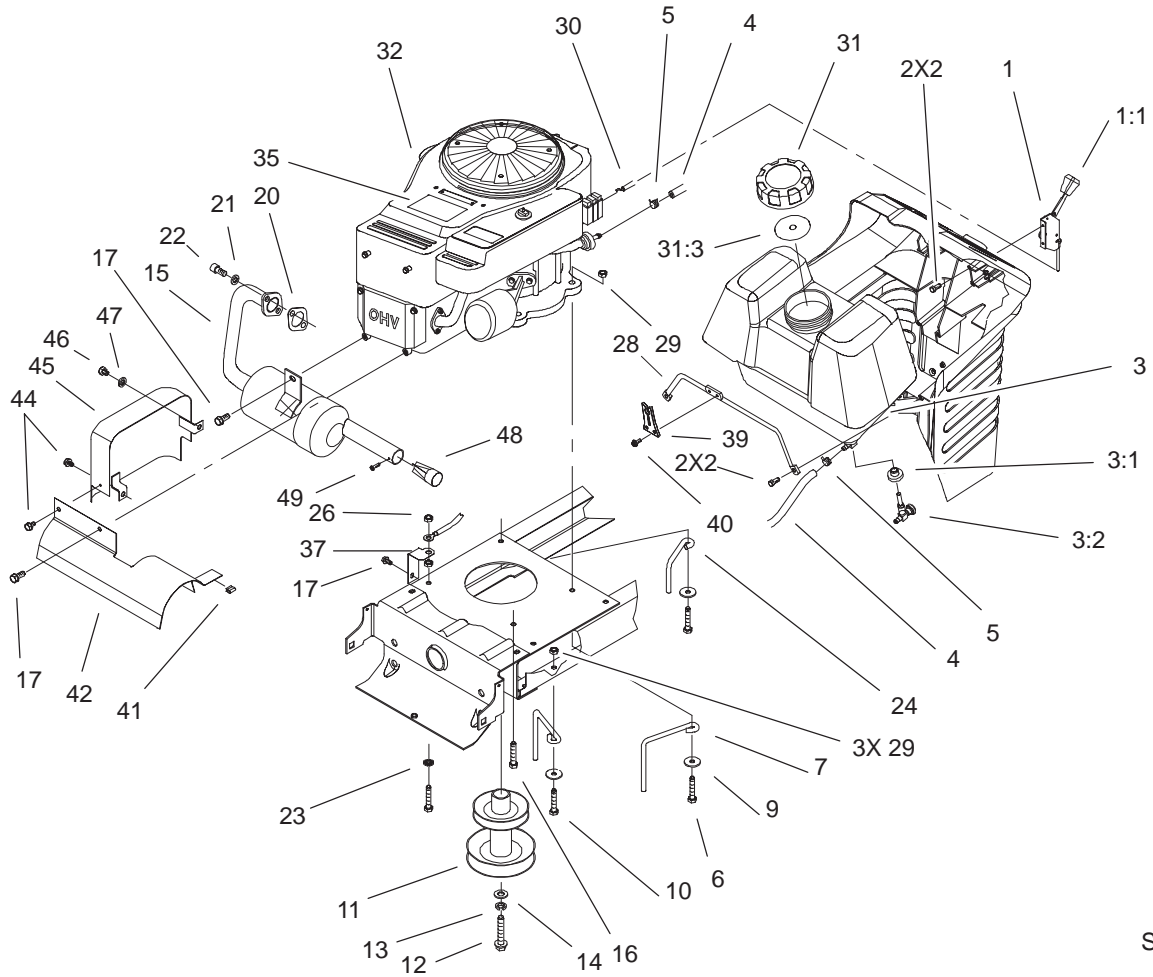

Sheet No.:7

## Engine System Assembly

Ref. No.	Part No.	Qty.	Description
1	88-4340	1	Control-Throttle
1:1	66-0120	1	Knob
2	27-0220	4	Screw-Special
3	88-3880	1	Gas Tank ASM
3:1	104047	1	Bushing
3:2	104048	1	Valve-Fuel
4	47-2963	1	Hose-Gas
5	2412-98	2	Clamp
6	322-9	3	Screw-HH
7	93-3854	3	Guide - Belt Engine
9	5-4460	4	Washer-Pivot
10	322-5	2	Screw-HH
11	100-7414	1	Pulley-Engine
12	62-3760	1	Screw-HH
13	3253-22	1	Washer-Lock
14	3256-25	1	Washer-Flat
15	99-6845	1	Muffler-17 HP
16	9267154	1	Screw
17	9266714	3	Screw-HWH
20	88-4410	1	Gasket-Muffler
21	3253-4	2	Washer-Lock
22	3274-10	2	Screw-HSH
23	3255-8	1	Washer-Lock/Ext
24	93-3855	1	Guide - Belt RH
26	32149-1	2	Nut
28	94-1952	1	Rod - Gas Tank

Ref. No.	Part No.	Qty.	Description
29	3296-29	4	Nut-Lock NI
30	88-4350	1	Cable-Throttle
31	88-3980	1	Gas Cap ASM
31:3	88-4010	1	Gasket-Cap, Gas
☆32		1	Engine-17.0 Briggs And Stratton Model 312777-0128-E1
35	99-8057	1	Decal - Engine
37	93-3809	1	Bracket- Ground
39	94-1951	1	Latch - Hood
40	32144-112	2	Screw-HWHTF
41	93-3882	1	Clip - Tinnerman, U
42	93-3880-03	1	Shield-Muffler
44	32104-76	2	Screw
45	93-8450-03	1	Exhaust Shield ASM
46	322-3	1	Screw-HH
47	3253-4	1	Washer-Lock
48	93-9911	1	Screen-Silencer, Exhaust
49	32144-42	1	Screw-HH

☆ Not serviced

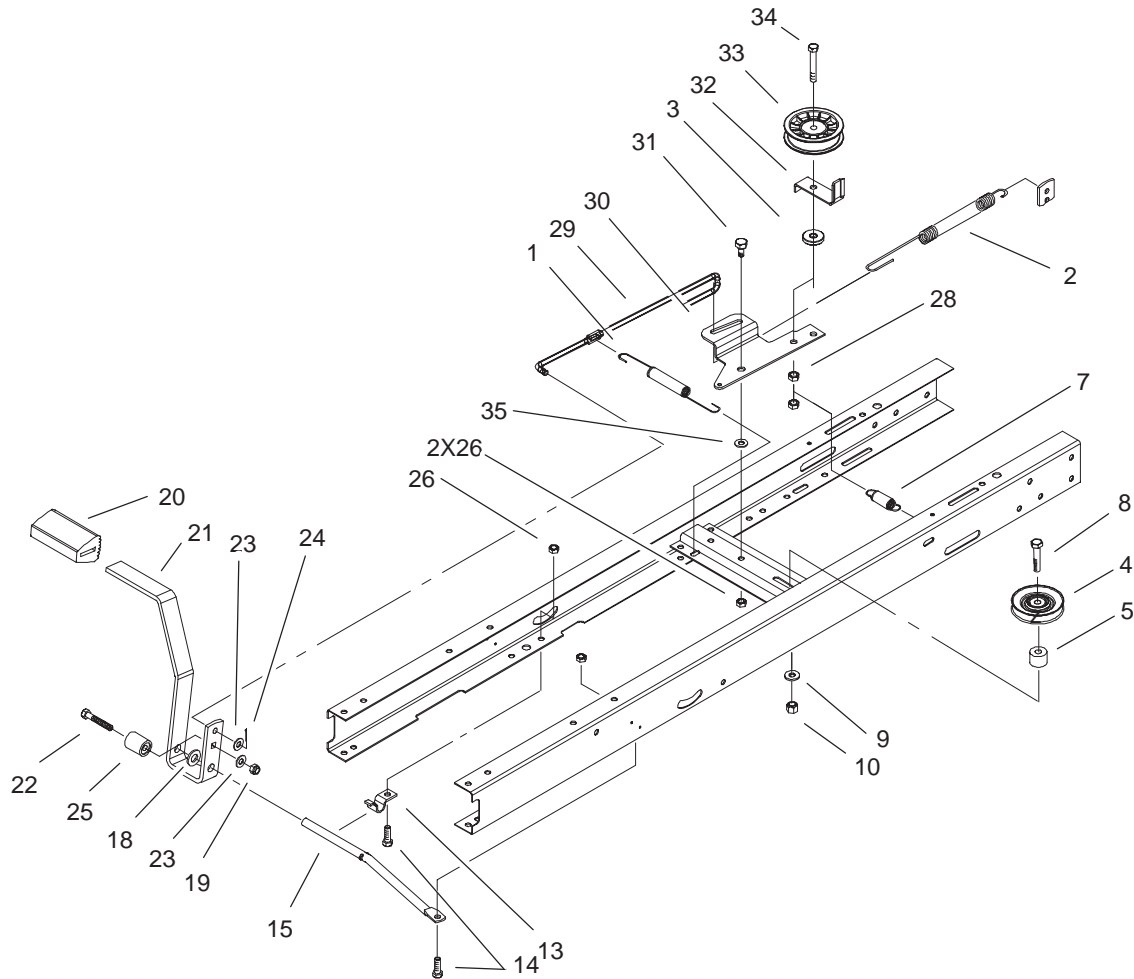

Sheet No.:8

### Traction Brake Assembly

Ref. No.	Part No.	Qty.	Description
1	27-8890	1	Spring-Return
2	100-7422	1	Spring-Brake
3	92-4890	1	Washer - Wheel
4	92-7102	1	Pulley-Idler
5	92-5791	1	Spacer
7	88-6330	1	Spring - Extension
8	323-10	1	Screw-HH
9	3256-3	1	Washer-Flat
10	3296-39	1	Nut-Lock, NI
13	88-4810	1	Clamp-Shift Pivot
14	322-3	2	Screw-HH
15	88-5500	1	Rod-Pedal Pivot
18	3256-26	1	Washer-Flat
19	3296-47	1	Nut-Lock, NI
20	65-2920	1	Pad-Pedal
21	88-5000-03	1	Pedal-Clutch/Brake
22	322-9	1	Screw-HH
23	3256-23	2	Washer-Flat
24	3272-10	1	Pin-Cotter
25	99-6836	1	Spacer-Switch
26	3296-29	3	Nut-Lock NI
28	3296-59	2	Nut-Lock NI
29	88-5270	1	Rod-Clutch/Brake
30	88-6070	1	Arm-Idler
31	37-8770	1	Bolt-Shoulder
32	88-5560	1	Guide-Idler Belt

Ref. No.	Part No.	Qty.	Description
33	104-4160	1	Pulley-Idler
34	323-11	1	Screw-HH
35	5-4460	1	Washer-Pivot

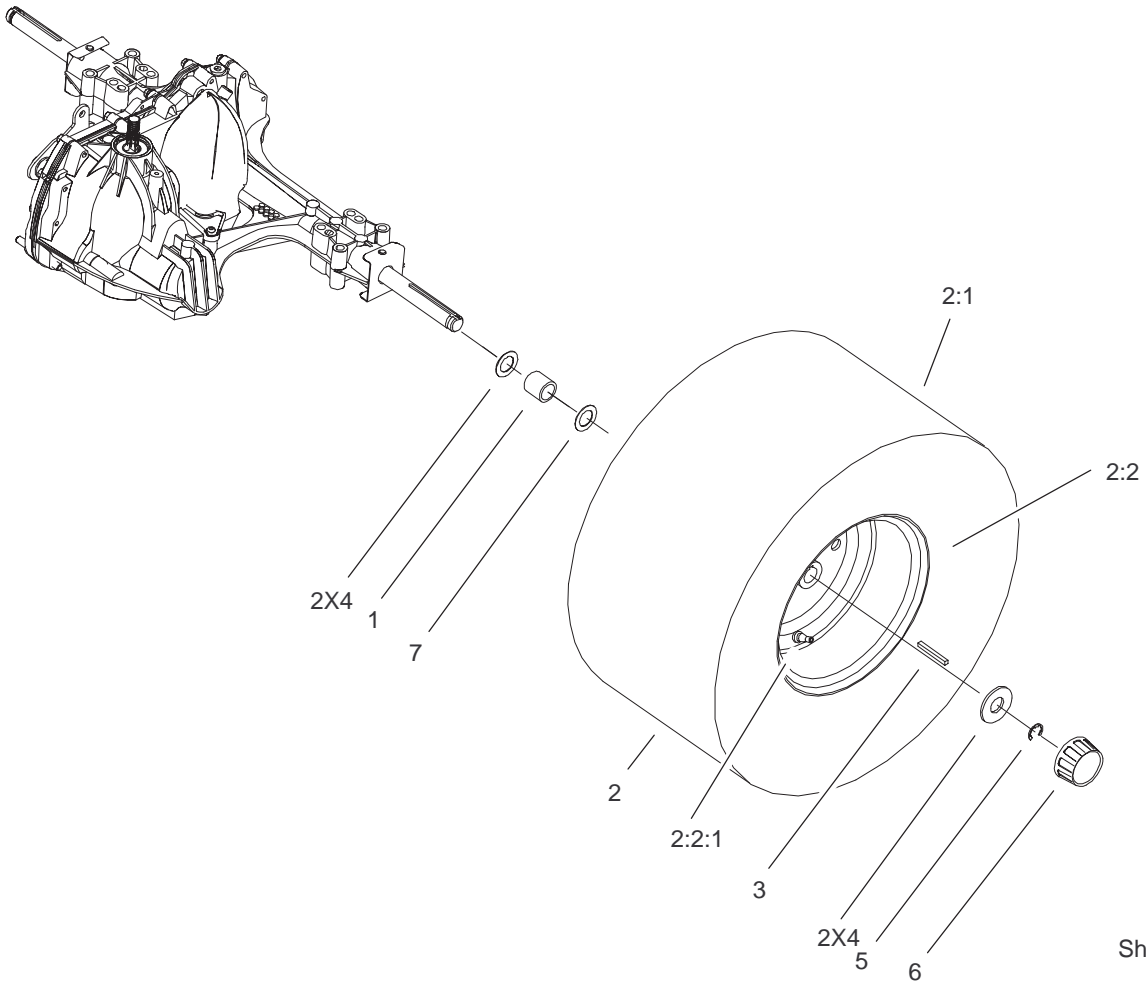

Sheet No.:9

## Wheel and Tire Assembly

Ref. No.	Part No.	Qty.	Description
1	104-4161	2	Spacer-Wheel
☆2		2	Rear Wheel & Tire ASM
2:1	99-2994	1	Tire
2:2	88-4390	1	Rim ASM
2:2:1	232-27	1	Stem-Valve
*	93-3893	1	Tube - Inner
3	7-0036	2	Key
4	28-2480	4	Washer
5	32151-48	2	E-Ring
6	61-9780	2	Cap-Hub
7	3-6498	2	Washer-Thrust

Ref. No.	Part No.	Qty.	Description

☆ Not serviced  
 \* Not illustrated



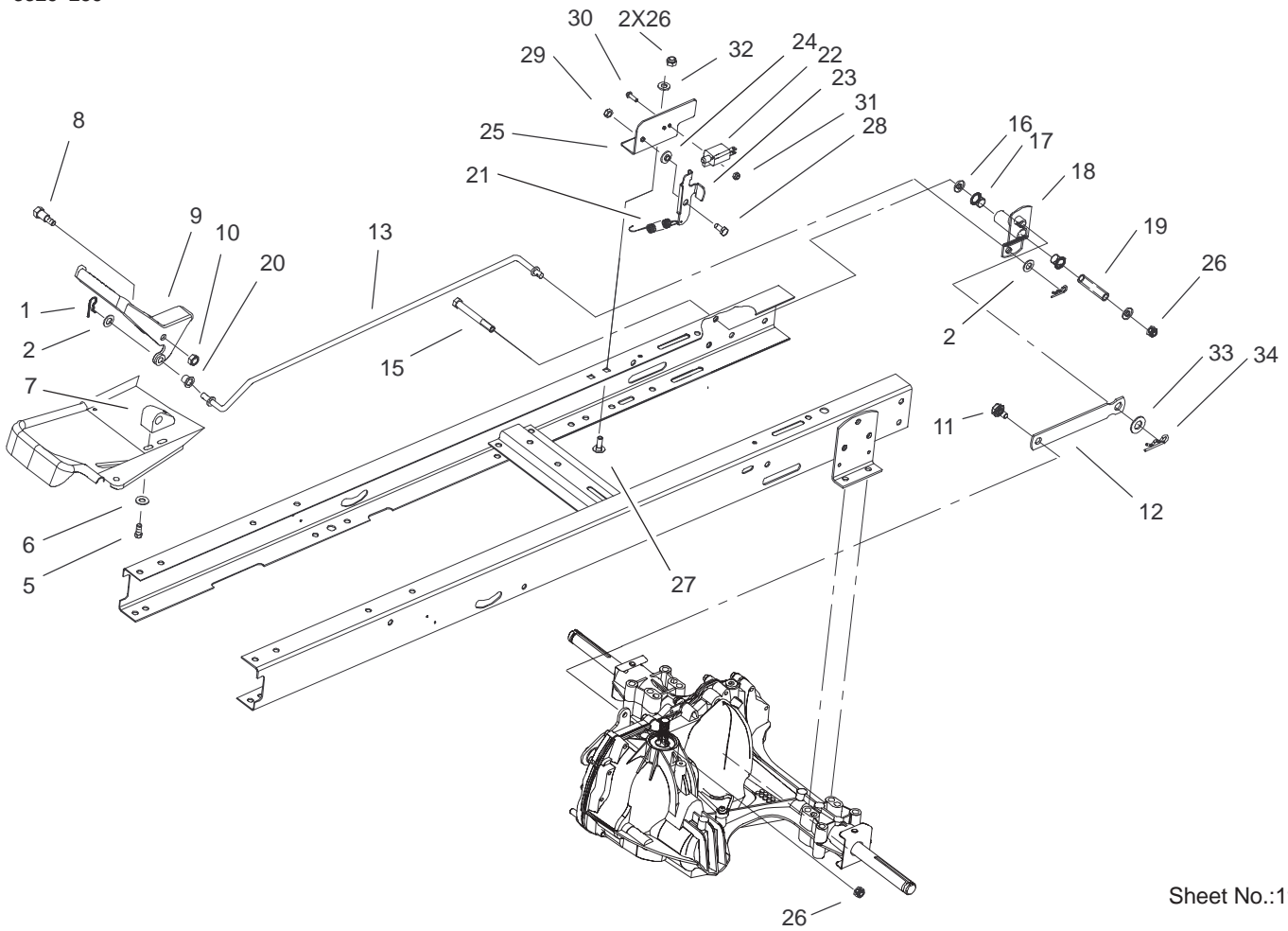

Sheet No.:11

## Hydro Transaxle Controls and NMIR Assembly

Ref. No.	Part No.	Qty.	Description
1	3290-307	2	Pin-Hair
2	3256-38	2	Washer-Flat
5	46-8090	2	Screw-Plastite
6	3256-22	2	Washer-Flat
7	88-4690	1	Block-Pivot
8	23-0310	1	Bolt-Shoulder
9	99-6120-05	1	Pedal-Speed Control
10	3296-59	1	Nut-Lock NI
11	37-8770	1	Bolt-Shoulder
12	99-6849	1	Link-Speed Control
13	99-6839	1	Rod-Speed Control
15	322-14	1	Screw-HH
16	3256-2	2	Washer-Flat
17	256-257	2	Flange-Nyliner
18	99-6835-03	1	Pivot ASM
19	99-6832	1	Spacer-Pivot
20	99-6121	1	Bushing
21	99-6805	1	Spring-Extension
22	95-1653	1	Switch - Single Pole
23	99-6807	1	Bracket - Pivot
24	99-6808	1	Washer-Stepped
25	99-6806	1	Bracket - Adjustment
26	3296-29	4	Nut-Lock NI
27	3230-18	2	Screw-CARR
28	99-6810	1	Screw-Hex Hd
29	3296-42	1	Nut-Lock, NI

Ref. No.	Part No.	Qty.	Description
30	3290-392	2	Screw - HHF
31	3296-1	2	Nut-Lock NI
32	3256-23	2	Washer-Flat
33	3256-26	1	Washer-Flat
34	9335054	1	Pin-Hair



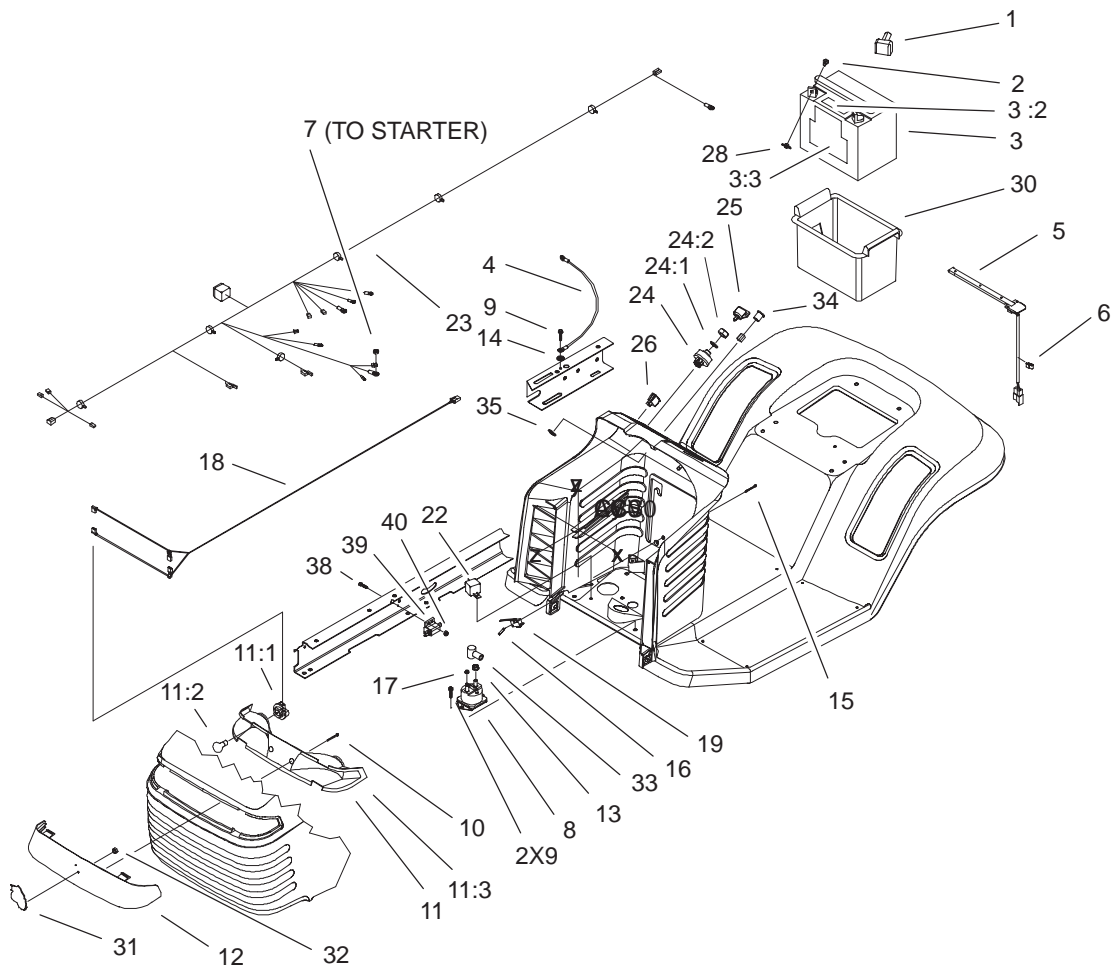

Sheet No.:13

## Electrical Assembly

Ref. No.	Part No.	Qty.	Description
1	28-8080	1	Boot-Terminal
2	321-4	2	Screw-HH
3	104-1755	1	Battery-155 Cca
3:2	104-4163	1	Decal-Battery
3:3	104-4164	1	Decal-Battery
4	44-8110	1	Wire ASM
5	38-1420	1	Switch-Seat
6	702366	1	Clip-Wire Retainer
7	32149-2	1	Nut
8	28-4210	1	Solenoid
9	9266714	3	Screw-HWH
10	32144-32	2	Screw
11	88-3970	1	Reflector And Lamp ASM
11:1	111686	2	Socket-Light
11:2	7228	2	Bulb -No. 1156
11:3	93-8741	1	Reflector
12	88-3960	1	Lens-Headlight
13	32149-1	2	Nut
14	3255-7	2	Washer-Lock/Ext
15	93-0539	2	Screw-HH
16	3290-354	1	Nut-Speed
17	32149-8	2	Nut-Keps
18	99-1935	1	Harness-Headlight
19	88-9932	1	Switch-Micro
22	98-7249	1	Relay

Ref. No.	Part No.	Qty.	Description
23	99-6840	1	Harness-Wire, Hydro
24	88-9830	1	Switch-Ignition
24:1	3254-5	1	Washer-Lock, Internal
24:2	218-461	1	Nut-HH
25	63-8360	1	Key-Ignition
26	92-8875	1	Switch - Rocker
28	32103-22	2	Nut-Wing
30	88-4040	1	Box-Battery
31	95-4248	1	Logo - Horsehead
32	3290-299	1	Clip
33	93-3190	1	Boot-Terminal Insulator
34	95-7652	1	Light - Indicator
35	99-6059	1	Clip-Retainer
38	3274-14	2	Screw-HSH
39	65-7410	1	Switch - Single Pole
40	3296-2	2	Nut-Lock

# Electrical Schematic

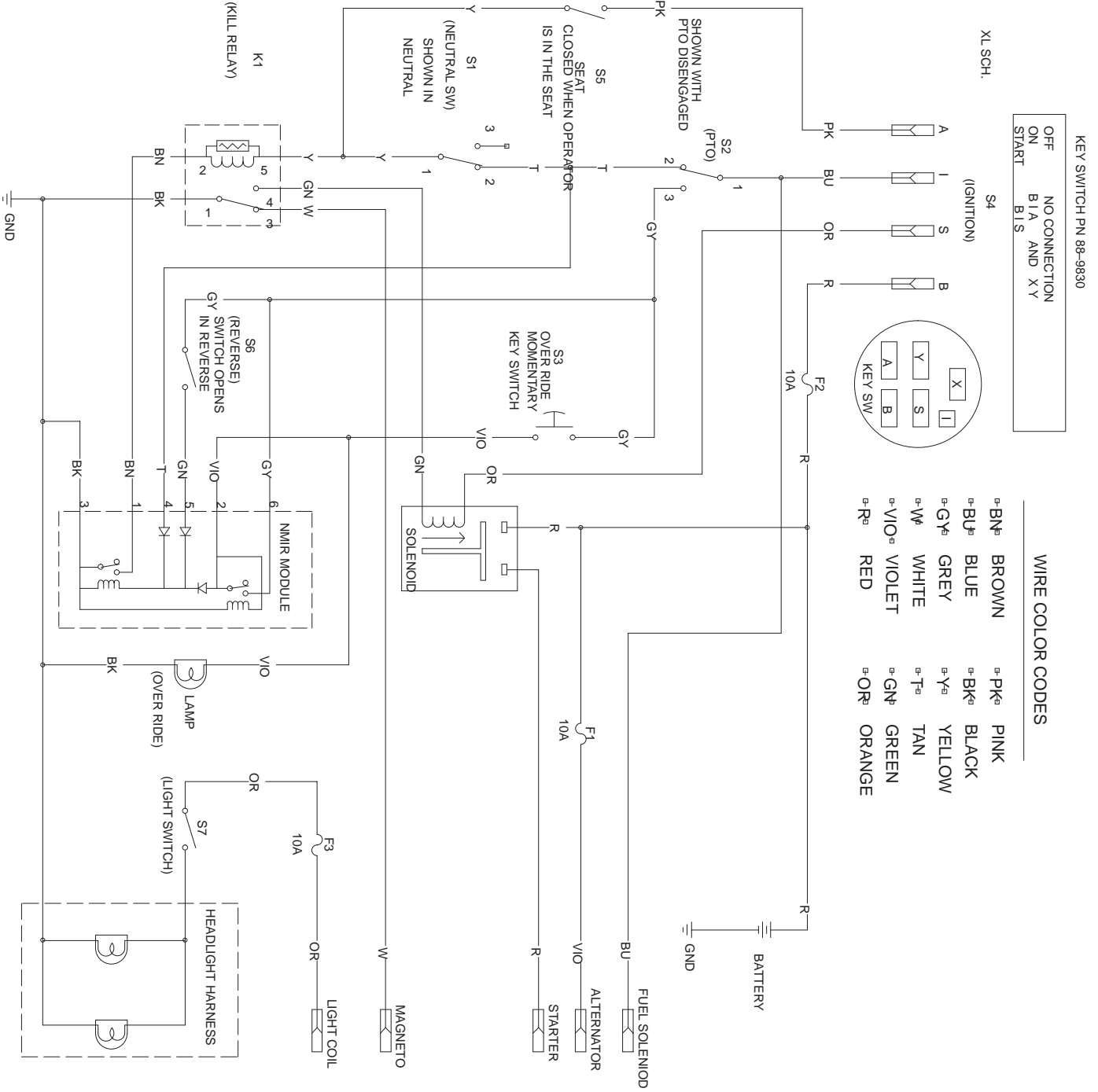

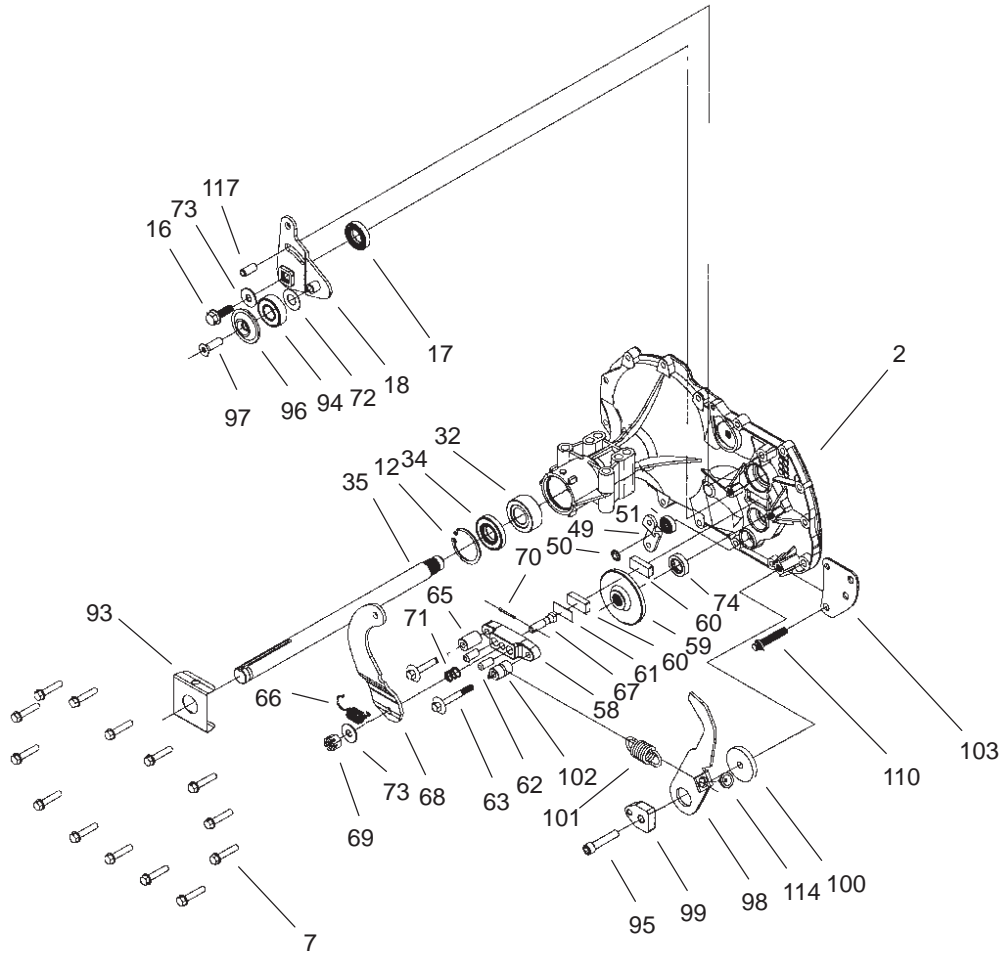

Sheet No.:3

## Housing and Bearing Assembly

Ref. No.	Part No.	Qty.	Description
02	104-5302	1	Side Housing ASM
07	104-5305	14	Screw-Hex Flange
12	104-5309	1	Ring-Retaining
16	104-5312	1	Screw-Hex Flange
17	104-5313	1	Seal-Lip
18	104-5314	1	Arm-Control
32	104-5321	1	Bearing-Sleeve, Outboard
34	104-5322	1	Seal-Lip
35	104-5323	1	Shaft-Axle RH
49	104-5336	1	Arm-Bypass
50	104-5337	1	Ring-Retaining
51	104-5338	1	Seal-Lip
58	104-5343	1	Yoke-Brake
59	104-5344	1	Rotor-Brake
60	104-2171	2	Puck-Brake
61	104-2181	1	Puck-Plate
62	104-2176	2	Pin-Brake
63	104-5345	2	Screw-Hex Flange
65	104-2180	1	Spacer
66	104-2184	1	Spring-Brake Arm Bias
67	104-2174	1	Bolt-Square Head
68	104-5346	1	Arm-Brake
69	93-3807	1	Nut - Castle
70	104-2179	1	Pin-Cotter

Ref. No.	Part No.	Qty.	Description
71	104-2188	1	Spring-Brake Anti Drag Comp.
72	94-1933	1	Washer
73	104-2146	2	Washer
74	104-5347	1	Seal-Oil
93	104-5353	1	Clip-Spring
94	104-2156	1	Bearing
95	104-2155	1	Screw
96	104-2157	1	Spacer-Locating
97	104-2158	1	Screw-Countersunk
98	104-5354	1	Arm-Return
99	104-2119	1	Puck-Adjusting
100	104-5355	1	Washer
101	104-5356	1	Spring-Extension
102	104-5357	1	Spacer
103	104-5358	1	Bracket-Torque
110	104-2148	1	Screw-Torx Head
114	104-5363	1	Guide-Spring
117	104-5365	1	Pin-Spring

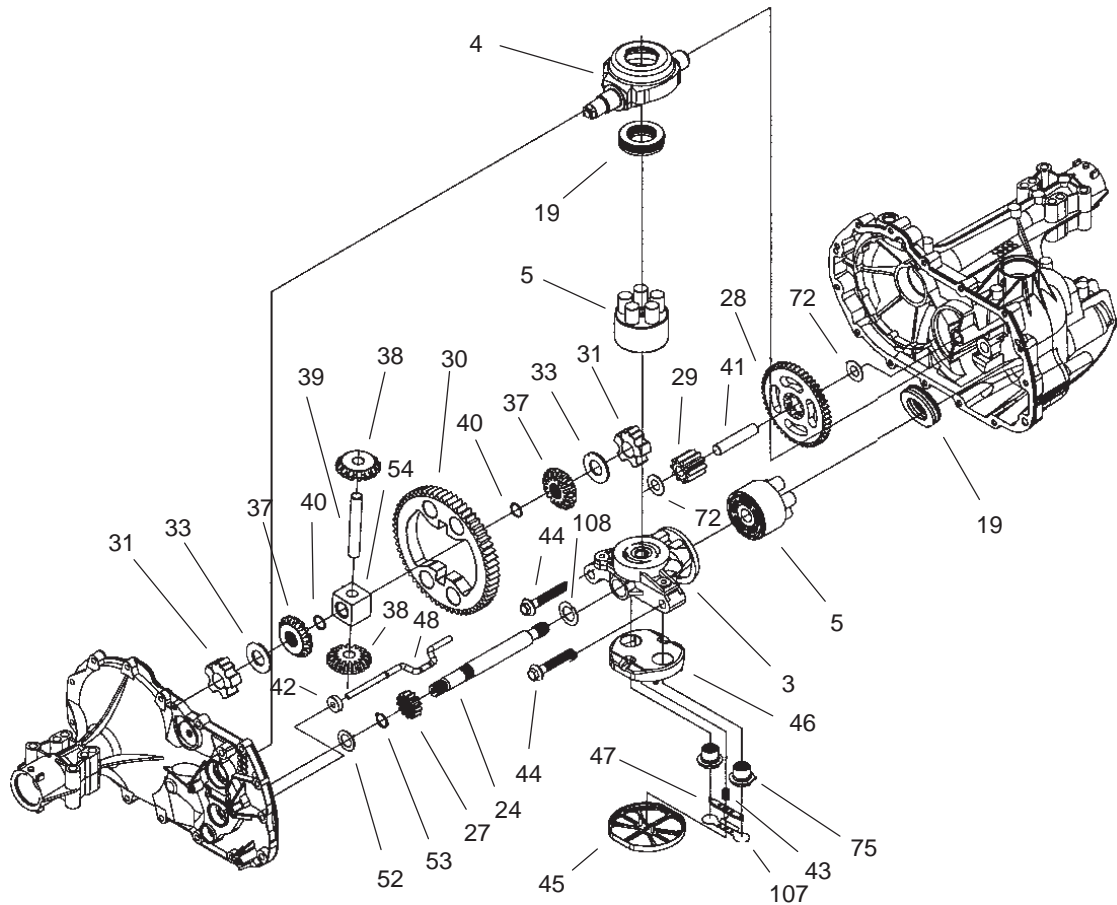

Sheet No.:4

## Gear Assembly

Ref. No.	Part No.	Qty.	Description	Ref. No.	Part No.	Qty.	Description
03	104-5303	1	Center Section ASM	53	104-5340	1	Ring-Retaining
04	104-5304	1	Swashplate-Trunnion Machined	54	104-5341	1	Bearing-Center Block
05	104-2106	2	10cc Cylinder Block ASM	72	94-1933	2	Washer
19	94-6922	2	Bearing - Thrust	75	104-5348	2	Check Plug ASM
24	104-5314	1	Arm-Control	107	104-5359	1	Deflector
27	104-5316	1	Gear-Pinion, 13t	108	104-5360	1	Washer-Motor Shaft
28	104-5317	1	Gear- 10t/48t				
29	104-5318	1	Gear-Jackshaft 10t				
30	104-5319	1	Gear-Bull 60t				
31	104-5320	2	Bearing-Sleeve				
33	94-1943	2	Washer				
37	104-5325	2	Gear-Miter				
38	104-5326	2	Gear-Miter 15t				
39	104-5327	1	Shaft				
40	104-5328	2	Ring-Spiral Retaining				
41	104-5329	1	Pin-Jackshaft				
42	104-5330	1	Magnet-Ring				
43	104-5331	1	Spring-Bypass				
44	94-6926	2	Bolt				
45	104-5332	1	Filter				
46	104-5333	1	Base-Filter				
47	104-5334	1	Actuator-Bypass				
48	104-5335	1	Rod-Bypass Actuator				
52	104-5339	1	Washer-Flat				

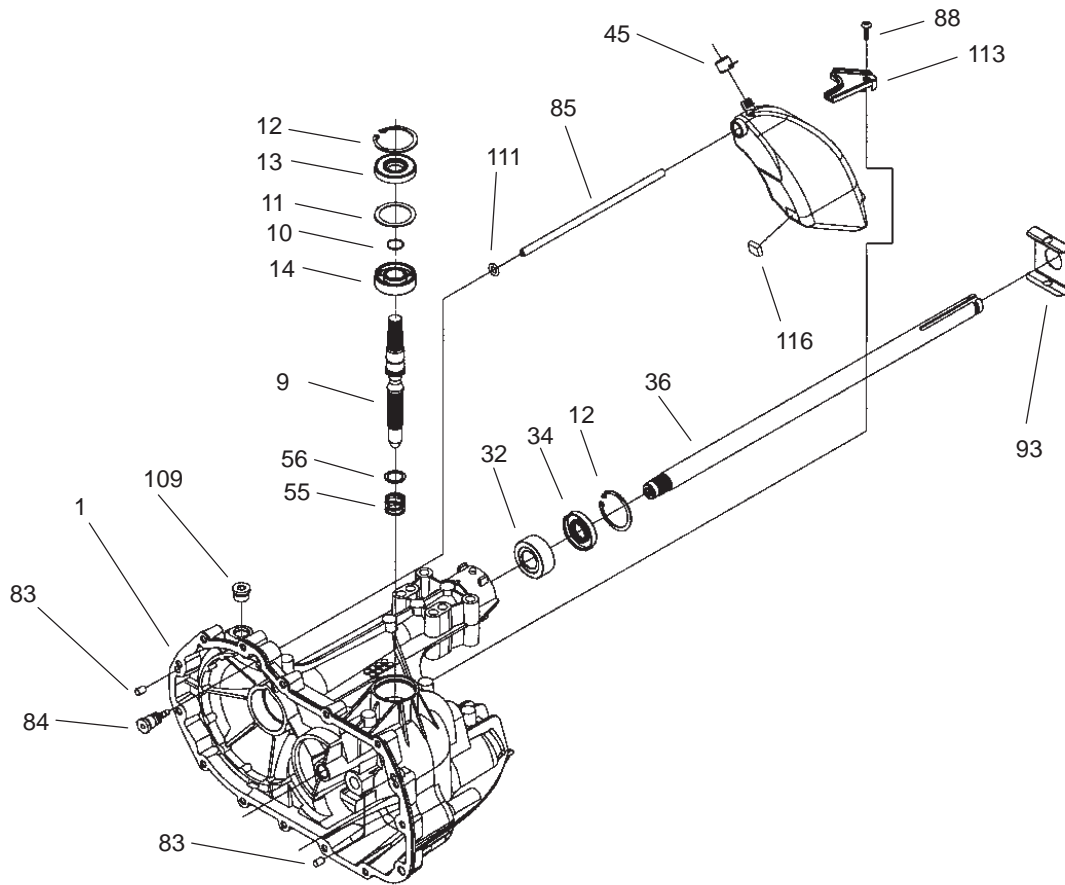

Sheet No.:5

### Axle Assembly

Ref. No.	Part No.	Qty.	Description
01	104-5301	1	Main Housing ASM
09	104-5306	1	Shaft-Input
10	104-5307	1	Ring-Retaining
11	104-5308	1	Spacer
12	104-5309	2	Ring-Retaining
13	104-5310	1	Seal-Lip
14	104-5311	1	Bearing-Ball
32	104-5321	1	Bearing-Sleeve, Outboard
34	104-5322	1	Seal-Lip
36	104-5324	1	Shaft-Axle LH
55	94-1936	1	Spring - Block
56	94-1937	1	Washer - Block Thrust
83	104-2170	2	Pin-STD Hols
84	104-5349	1	Fitting-Sae
85	104-5350	1	Hose-Expansion Tank
87	104-5351	1	Cap-Vent
88	104-5352	1	Bolt-Self Tapping
93	104-5353	1	Clip-Spring
111	104-5361	1	O-Ring
113	104-5362	1	Bracket-Support
116	104-5364	1	Sponge-silicone

Ref. No.	Part No.	Qty.	Description



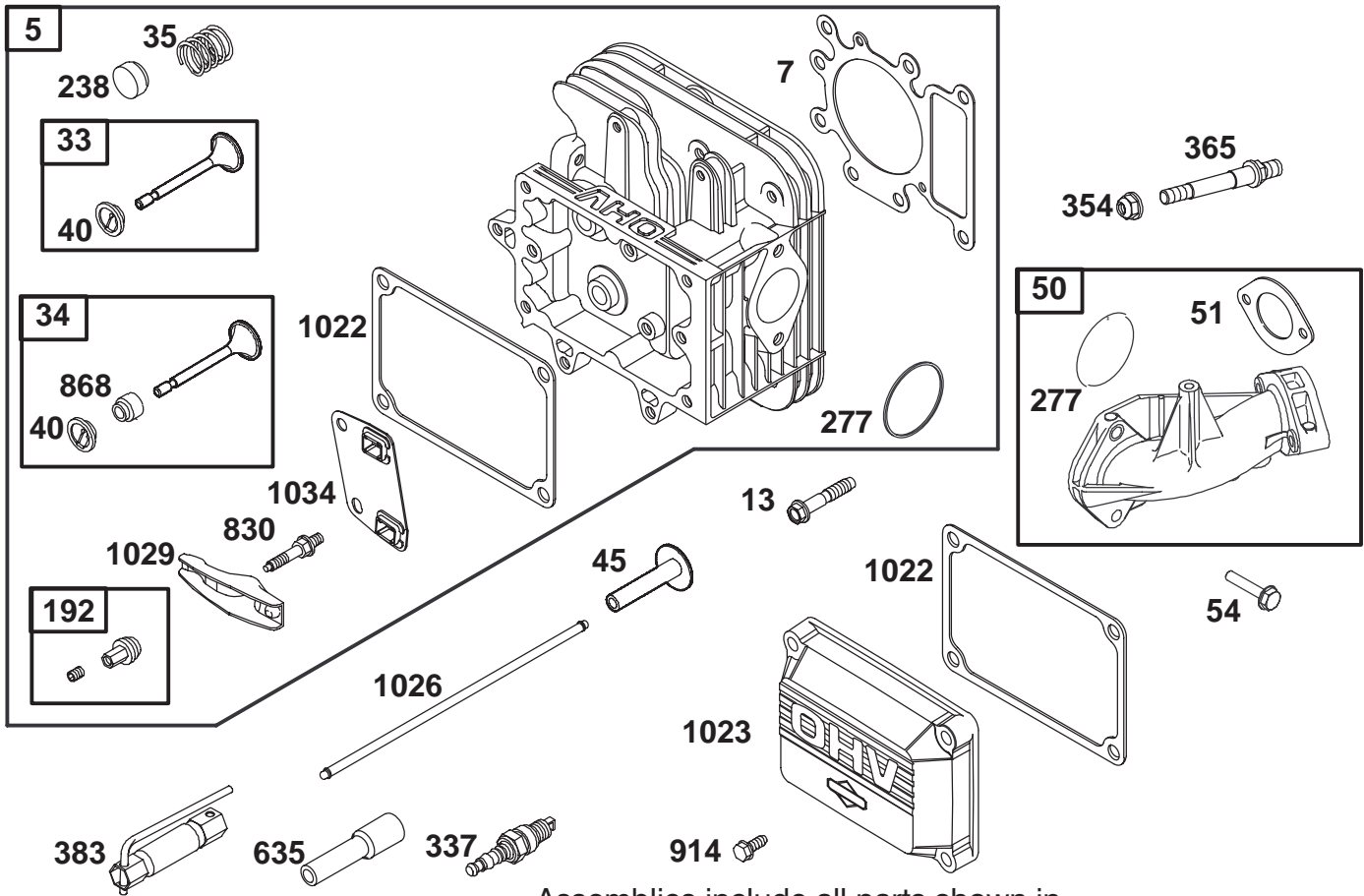

Assemblies include all parts shown in frames.

## Cylinder Head Assembly Briggs and Stratton Model 312777-0128-E1

Ref. No.	Part No.	Qty.	Description
5	690188	1	Head-Cylinder
▲★7	692410	1	Gasket-Cylinder Head
13	690360	1	Screw-Hex.
33	495856	1	Valve-Exhaust
34	495857	1	Valve-Intake
35	262811	1	Spring-Valve
40	224641	1	Retainer-Valve
45	262411	1	Tappet-Valve
50	690193	1	Manifold-Intake
■51	273650	1	Gasket-Intake
54	95160	1	Screw-Hex.
192	492160	1	Adjuster-Rocker Arm
238	262836	1	Cap-Valve
▲★277	692138	1	Seal-O-Ring
337	491055	1	Plug-Spark
354	94010	1	Nut-Hex.
365	690227	1	Stud-Carburetor Mtg.
383	89838	1	Wrench-Spark Plug
635	280872	1	Boot-Spark Plug
830	94555	1	Stud-Rocker Arm
▲★868	499236	1	Seal-Valve
914	94682	1	Screw-Hex.
▲★1022	272475	1	Gasket-Rocker Cover
1023	690388	1	Cover-Rocker

Ref. No.	Part No.	Qty.	Description
1026	494432	1	Rod-Push Intake Rod-Push Exhaust
1029	224554	1	Arm-Rocker
1034	495248	1	Guide-Push Rod

★ Included in Gasket Set-Ref. 358.

▲ Included in Valve Overhaul Kit-Ref. 1033. ■ Included in Kits ★ ▲ ● ◆.

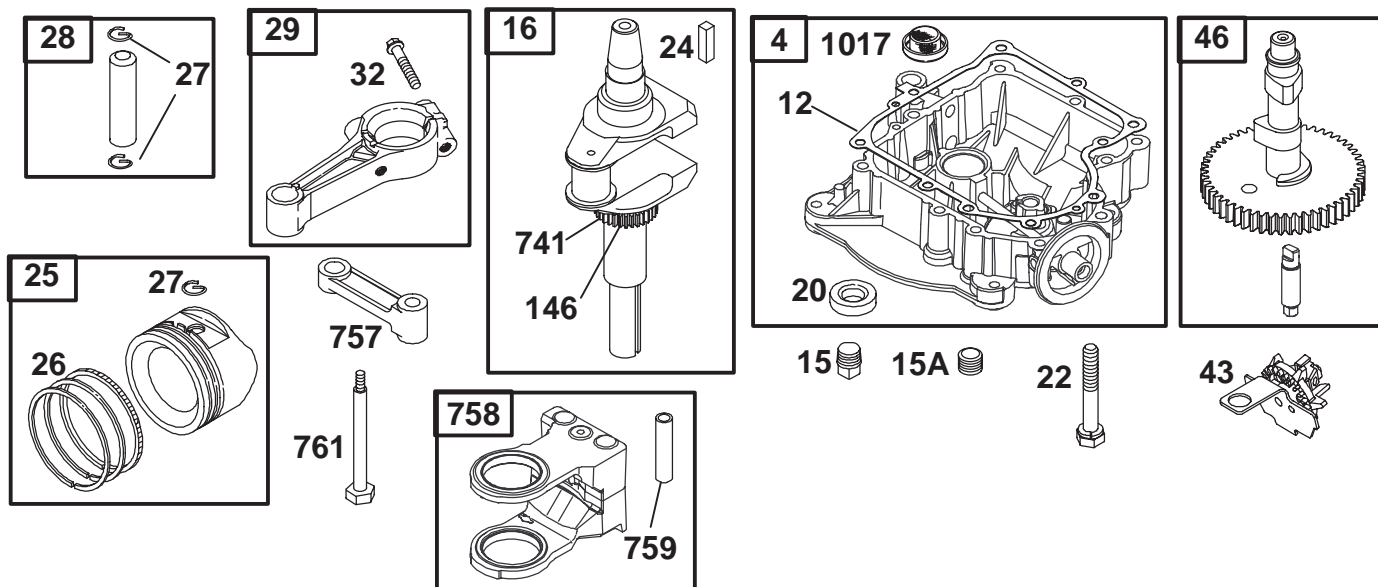

Assemblies include all parts shown in frames.

## Crankcase Assembly Briggs and Stratton Model 312777-0128-E1

Ref. No.	Part No.	Qty.	Description
4	693582	1	Sump-Engine
★12	271916	1	Gasket-Crankcase
		1	015" Thick
		1	Gasket-Crankcase
		1	005" Thick
		1	Gasket-Crankcase
		1	009" Thick
15	94239	1	Plug-Oil Drain
15A	91488	1	Plug-Oil Drain
16	690136	1	Crankshaft
★20	291675	1	Seal-Oil
22	692125	1	Screw-Hex.
24	222698	1	Key-Flywheel
25	692271	1	Piston Assembly
		1	Standard
		1	Piston Assy .010" O.S.
		1	Piston Assy..020" O.S.
		1	Piston Assy..030" O.S.
26	690162	1	Ring Set Standard
		1	Ring Set .010" O.S.
		1	Ring Set .020" O.S.
		1	Ring Set .030" O.S.
27	263129	1	Lock-Piston Pin
28	498319	1	Pin-Piston Standard

Ref. No.	Part No.	Qty.	Description
		1	Pin-Piston .005" O.S.
29	692419	1	Rod-Connecting
		1	Standard
		1	Rod- Connecting .020"
		1	Undersize
32	692852	1	Screw-Connecting Rod
43	490815	1	Governor/Oil Slinger
46	693450	1	Gear-Cam
146	94196	1	Key-Timing
741	262932	1	Gear-Timing
757	213998	1	Link-Counterweight
758	499994	1	Counterweight
759	230787	1	Pin-Counterweight
761	94593	1	Screw-Hex.
1017	693292	1	Screen-Oil Pump

★ Included in Gasket Set-Ref. 358.

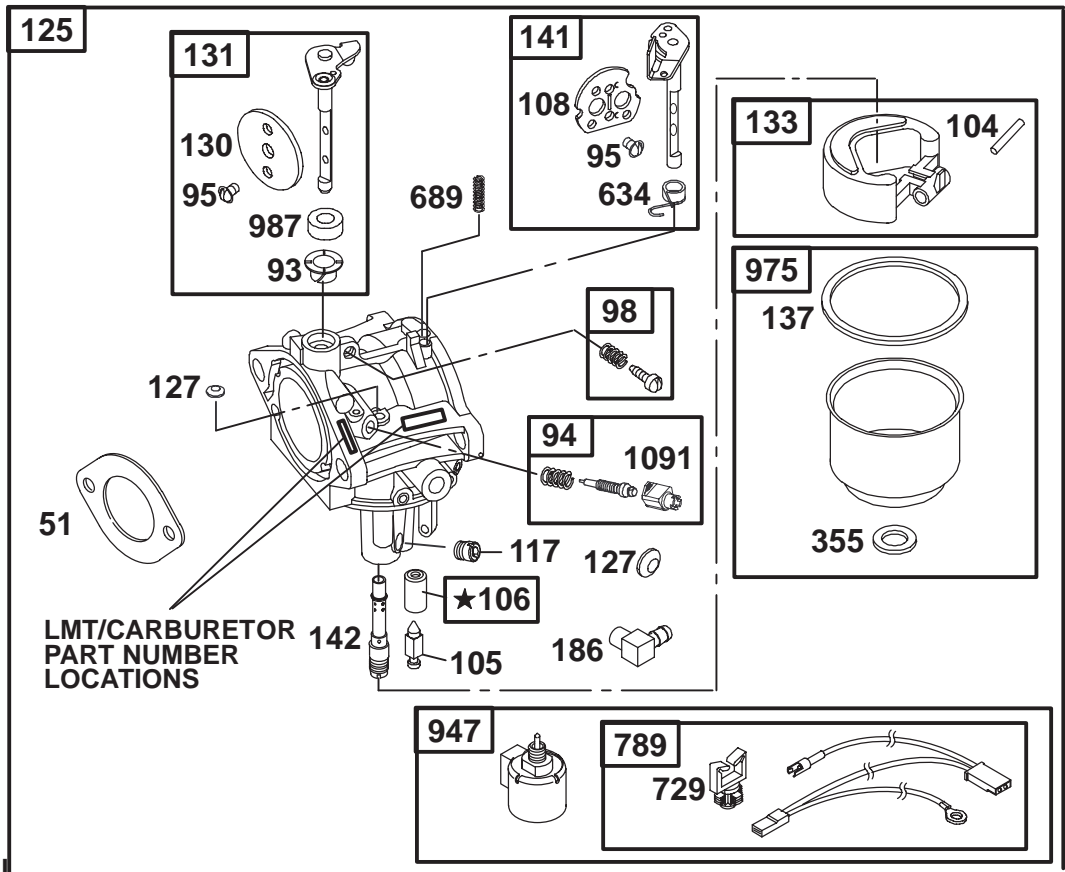
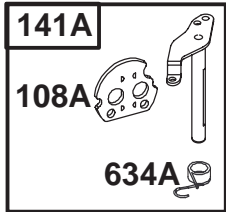

★ REQUIRES SPECIAL TOOLS TO INSTALL. SEE REPAIR INSTRUCTION MANUAL

Assemblies include all parts shown in frames.

## Carburetor Assembly Briggs and Stratton Model 312777-0128-E1

Ref. No.	Part No.	Qty.	Description
●51	273650	1	Gasket-Carburetor
●93	281346	1	Bushing-Throttle Shaft
94	498030	1	Valve-Idle Adjust
●95	94098	1	Screw-Round Head
98	495800	1	Screw-Idle Adjust
●104	231789	1	Pin-Float Hinge
●105	231855	1	Valve-Inlet Needle
●106	231854	1	Seat-Inlet
108	224558	1	Valve-Choke (Manual)
108A	224540	1	Valve-Choke (Remote)
●117	232118	1	Jet-Main (Standard)
		1	Jet-Main (High Altitude)
125	499153	1	Carburetor
●127		1	Plug-Welch (Sold in Kit Only)
130	224539	1	Valve-Throttle
131	494379	1	Shaft-Throttle
133	494381	1	Float-Carburetor
◆137	281165	1	Gasket-Float Bowl
141	495097	1	Shaft-Choke (Manual)
141A	495931	1	Shaft-Choke (Remote)
●142	232117	1	Nozzle-Carburetor
186	493496	1	Elbow-Fuel Pipe

Ref. No.	Part No.	Qty.	Description
●◆355	281164	1	Washer-Float Bowl
●634	494453	1	Seal-Spring Assembly
●634A	494455	1	Seal-Spring Assembly
689	262715	1	Spring-Friction
789	497708	1	Harness-Wiring
947	497672	1	Solenoid
975	495933	1	Bowl-Float
●987	281166	1	Seal-Throttle Shaft
1091	691333	1	Cap-Limiter

● Included in Carburetor Kit-Ref. 121. ◆ Included in Carburetor Gasket Set-Ref. 977.

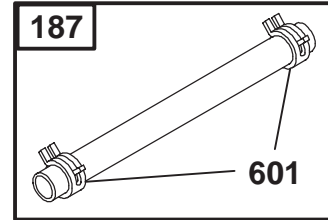
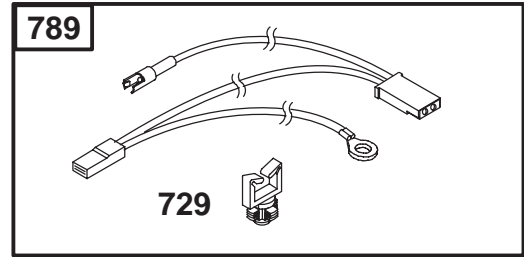
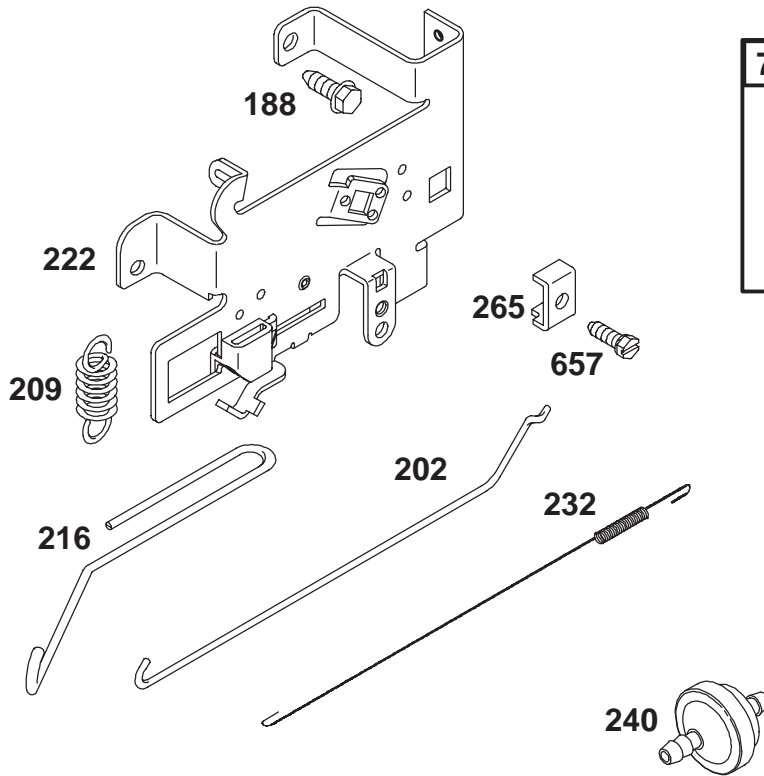

Assemblies include all parts shown in frames.

## Governor Assembly Briggs and Stratton Model 312777-0128-E1

Ref. No.	Part No.	Qty.	Description
187	298049	1	Line-Fuel Cut to Required Length
188	94929	1	Screw-Hex.
202	262767	1	Link-Choke
209	260695	1	Spring-Governor
216	262766	1	Link-Choke
222	694042	1	Bracket-Control
232	262785	1	Spring-Link
240	394358	1	Filter-Fuel
265	221535	1	Clamp-Casing
601	95162	1	Clamp-Hose
657	94906	1	Screw-Slotted Hex.
729	281390	1	Clip-Wire
789	497708	1	Harness-Wiring

Ref. No.	Part No.	Qty.	Description

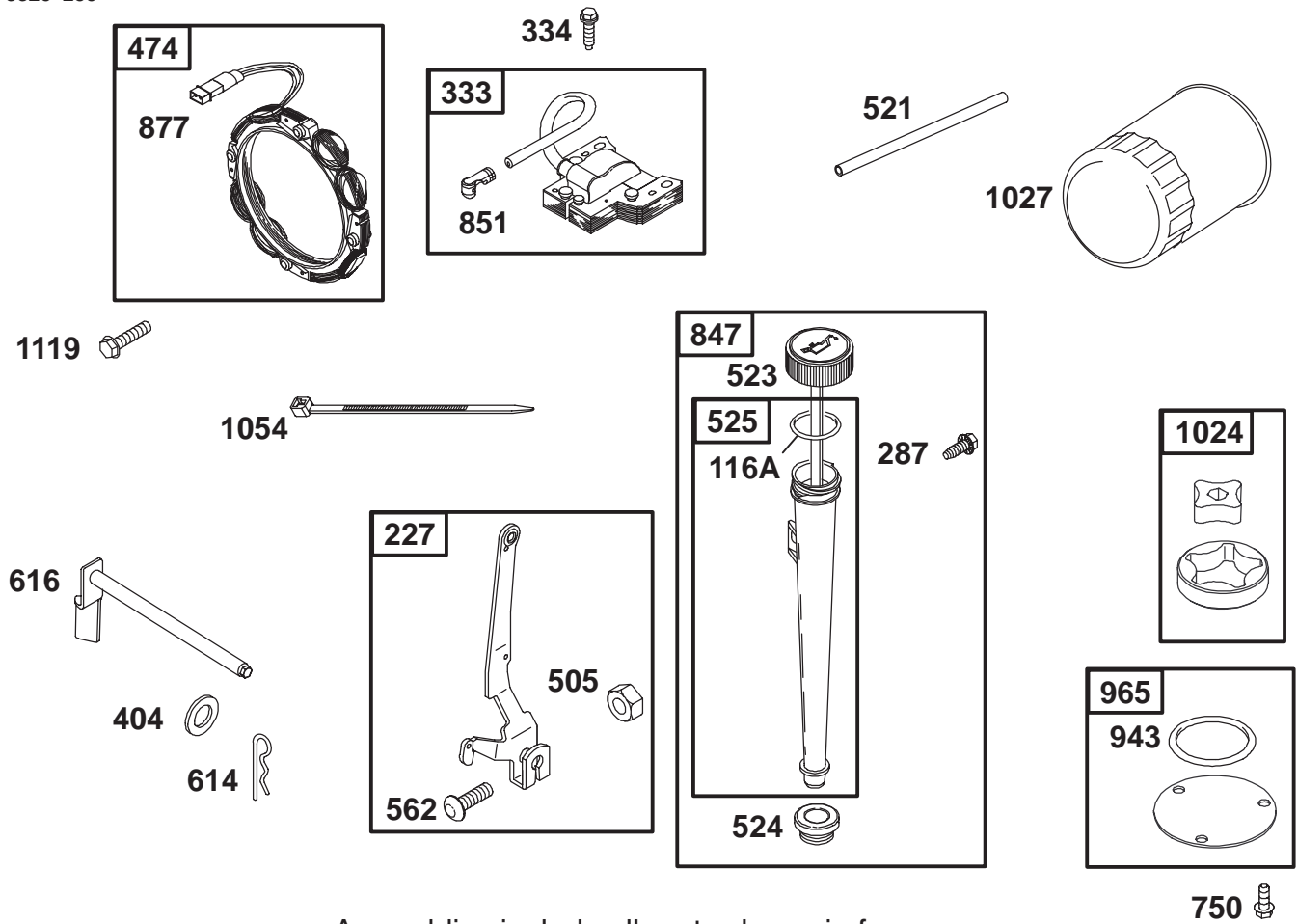

Assemblies include all parts shown in frames.

## Oil Filter, Tube, and Pump Assembly Briggs and Stratton Model 312777-0128-E1

Ref. No.	Part No.	Qty.	Description
★116A	270920	1	Seal-O-Ring
227	493935	1	Lever-Governor
287	94903	1	Screw-Shoulder
333	495859	1	Armature-Magneto
334	94731	1	Screw-Hex.
404	94927	1	Washer-Flat
474	393474	1	Alternator
505	231978	1	Nut-Hex.
521	690581	1	Shield-Cable
523	495230	1	Dipstick
★524	281370	1	Seal-Fill Tube
525	691398	1	Tube-Oil Fill
562	94907	1	Bolt-Governor Lever
614	93306	1	Pin-Cotter
616	495157	1	Crank-Governor
750	691033	1	Screw-Hex.
847	496415	1	Dipstick/Tube Assembly
851	224110	1	Terminal-Cable
877	393456	1	Connector-Alt. Output
★943	280801	1	Seal-O-Ring
965	499613	1	Cover-Pump
1024	499054	1	Pump-Oil
1027	492932	1	Filter-Oil

Ref. No.	Part No.	Qty.	Description
1054	280275	1	Tie-Cable
1119	93621	1	Screw-Hex.

★ Included in Gasket Set-Ref. 358.







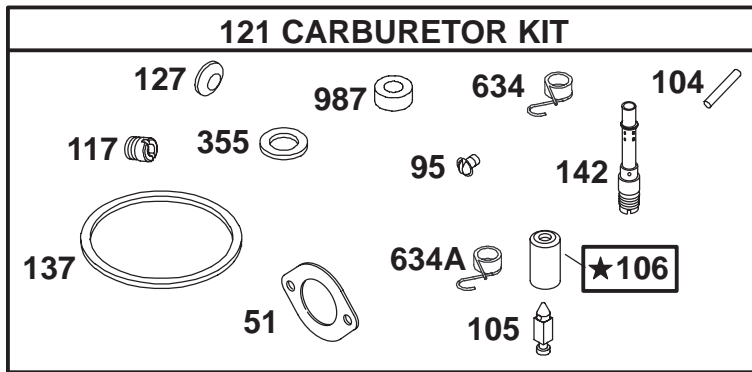

★ REQUIRES SPECIAL TOOLS TO INSTALL. SEE REPAIR INSTRUCTION MANUAL.

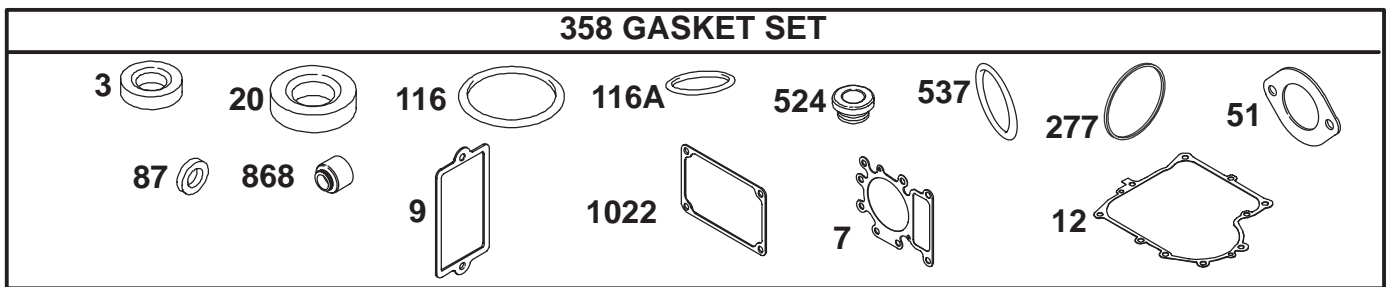
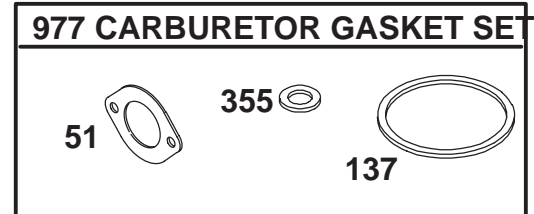
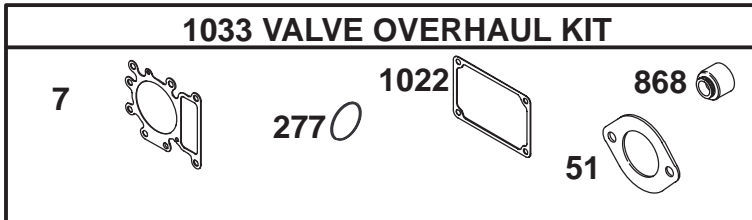

Assemblies include all parts shown in frames.

## Carburetor Overhaul Kit Assembly Briggs and Stratton Model 312777-0128-E1

Ref. No.	Part No.	Qty.	Description
★3	391086	1	Seal-Oil
▲★7	692410	1	Gasket-Cylinder Head
★9	27803	1	Gasket-Breather
★12	271916	1	Gasket-Crankcase
		1	.015" Thick
		1	Gasket-Crankcase
		1	.005" Thick
		1	Gasket-Crankcase
		1	.009" Thick
★20	291675	1	Seal-Oil
■51	273650	1	Gasket-Intake
★87	491323	1	Seal-Governor Shaft
●95	94098	1	Screw-Choke/Throttle
●104	231789	1	Pin-Float Hinge
●105	231855	1	Valve-Needle
●106	231854	1	Seat-Inlet
★116	280801	1	Seal-O-Ring
★116A	270920	1	Seal-O-Ring
●117	232118	1	Jet-Main
121	690191	1	Carburetor Kit
●127		1	Plug-Welch
		1	Sold In Kit Only
◆●137	281165	1	Gasket-Float Bowl
●142	231117	1	Nozzle-Carburetor

Ref. No.	Part No.	Qty.	Description
▲★277	692138	1	Seal-O-Ring
◆●355	281164	1	Washer-Seal
	358 690189	1	Gasket Set
★524	281370	1	Seal-Fill Tube
★537	281106	1	Gasket-Air Cleaner
●634	494453	1	Seal-Spring
●634A	494455	1	Assembly LMT 155
		1	Seal-Spring
		1	Assembly LMT 154
▲★868	499236	1	Seal-Valve
	977 690192	1	Gasket Set-Carburetor
●987	281166	1	Seal-Throttle Shaft
▲★1022	272475	1	Gasket-Rocker Cover
	1033 690190	1	Kit-Valve Overhaul

★ Included in Gasket Set-Ref. 358. ● Included in Carburetor Kit-Ref. 121. ■ Included in Kits ★ ▲ ● ◆.

▲ Included in Valve Overhaul Kit-Ref. 1033. ◆ Included in Carburetor Gasket Set-Ref. 977.







