

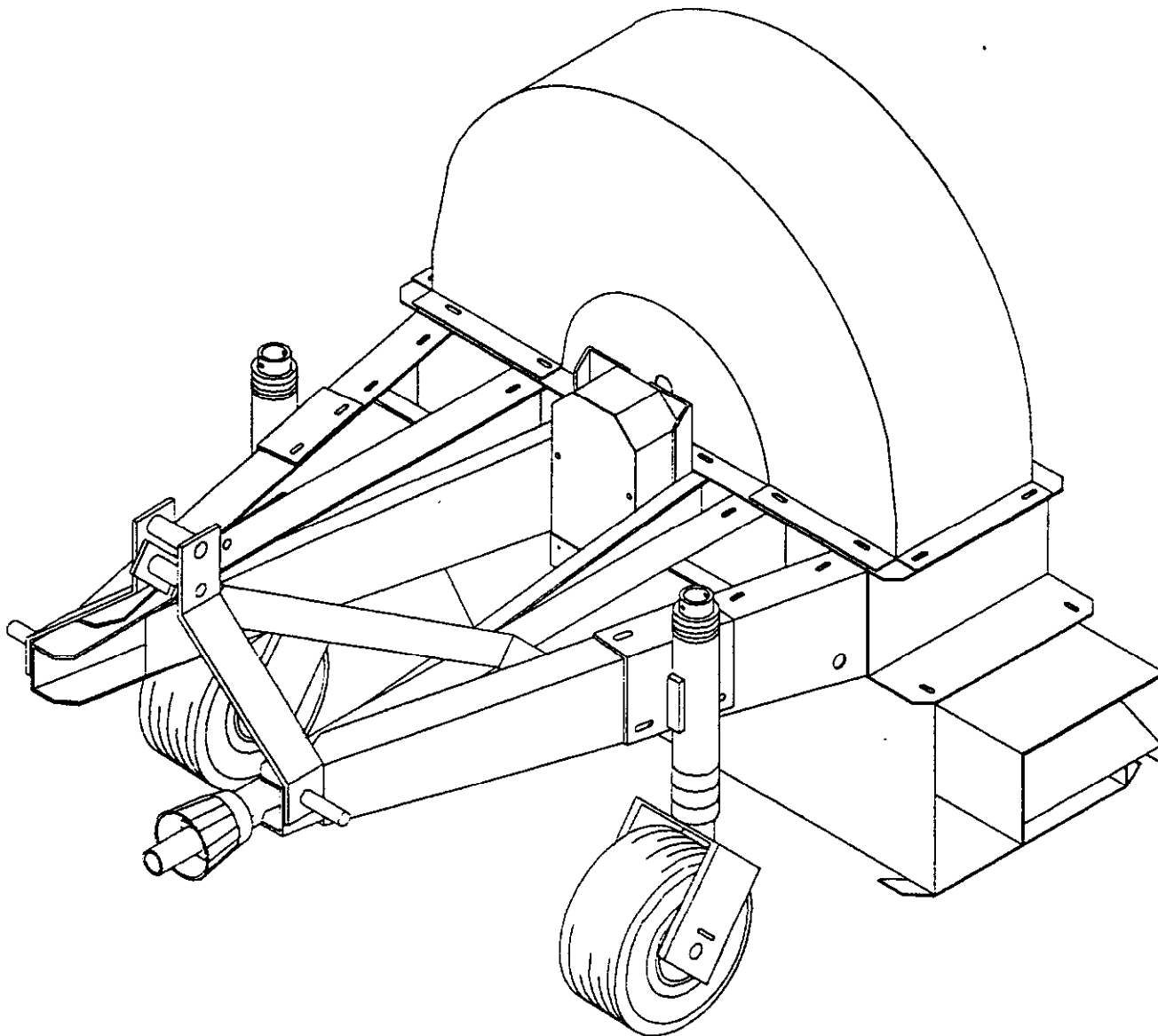

MODEL NO. 44520 - 20101 & UP	OPERATOR'S MANUAL
DEBRIS BLOWER 2613	



# FOREWORD

Thank you for buying a high quality Toro turf care product. To get the best performance from this machine, operate and maintain it according to the instructions in this manual.

Toro also wants to stress the importance of safety. You and anyone else using or maintaining this machine are strongly urged to read this manual, especially all the safety instructions.

**DANGER, WARNING and CAUTION**, used with the triangular safety alert symbol, highlight safety messages. Always read and understand these messages because they relate to personal injury and your safety.

If you ever need help or have questions about your new Toro turf care product, contact your local Authorized Toro Distributor. The Toro Distributor has a complete supply of replacement parts, a full line of accessories and a professional service staff to support you. Keep your Toro all Toro. Buy genuine Toro parts and accessories.

# TABLE OF CONTENTS

	Page		Page
SAFETY INSTRUCTIONS .....	3 - 4	MAINTENANCE .....	10
SAFETY AND INSTRUCTION DECALS .....	5	TROUBLE SHOOTING .....	11
SPECIFICATIONS .....	6	IDENTIFICATION AND ORDERING .....	12
BEFORE OPERATING .....	7	MAINTENANCE CHART .....	13 - 15
OPERATING INSTRUCTIONS .....	8	THE TORO PROMISE .....	Back Cover
LUBRICATION .....	9		

## SAFETY INSTRUCTION



The safety alert symbol means CAUTION, WARNING or DANGER - "personal safety instruction". Read and understand the instruction because it has to do with safety. Failure to comply with the instruction may result in personal injury.

### BEFORE OPERATING

1. Read and understand the contents of this manual before starting and operating the machine. Become familiar with all controls and know how to stop quickly. A free replacement manual is available by sending complete Model and Serial Number to:

**The Toro Company**  
100 Industrial Parkway  
Industrial Airport, Kansas 66031

2. Do not allow children to operate the machine. Do not allow adults to operate the machine without proper instruction.

3. **Never** operate the machine while under the influence of drugs or alcohol.

4. Keep all shields and safety devices in place. If a shield, safety device or decal becomes damaged, malfunctioning or illegible, repair or replace it before operation is commenced. Also tighten loose nuts, bolts to ensure machine is in safe operating condition. This includes all shields on the PTO.

5. Before each use, be sure all bolts and nuts are tight. Check the general condition of the PTO and chain.

6. Do not alter this equipment in any manner which may cause hazardous conditions.

### WHILE OPERATING



### WARNING

**DISCHARGED AIR HAS CONSIDERABLE FORCE AND COULD CAUSE INJURY OR LOSS OF FOOTING**

- Stay away from discharge opening when machine is running.
- Keep bystanders away from discharge opening when machine is running.

7. Using the machine demands attention, and to prevent loss of control:

A. Operate only in daylight or when there is good artificial light.

B. Drive slowly.

C. Watch for hole or other hazards.

D. Look behind machine before backing up.

E. Do not drive close to a sand trap, ditch, creek or other hazard.

F. Reduce speed when making sharp turns and when turning on a hillside.

G. Avoid sudden stops and starts.

# SAFETY INSTRUCTIONS

8. Operator must be skilled and trained in how to drive on hillsides. Failure to use caution on slopes or hills may cause loss of control possibly resulting in personal injury or death.

9. If engine stalls or machine loses headway and cannot make it to the top of a slope, do not turn machine around. Always back slowly straight down the slope.

10. Do not carry passengers on the machine or tractor and keep everyone away from the areas of operation.

11. Before getting off the tractor seat:

A. Place the tractor in neutral position and put the engine in idle position.

B. Set the parking brake and disengage the PTO.

C. Shut the engine off and remove key from ignition switch. Wait for all movement to stop before getting off tractor seat.

12. ALWAYS follow all safety precautions in the tractor's operator manual pertaining to attachments.

## MAINTENANCE

13. Remove the key from the tractor's ignition switch to prevent accidental starting of the engine when servicing, adjusting or storing the machine.

14. If major repairs are ever needed or assistance desired, contact an Authorized TORO Distributor.

15. Make sure machine is in safe operating condition by keeping nuts, bolts and screws tight.

# SAFETY AND INSTRUCTION DECALS

The following safety and instruction decals are installed on the unit. Replace any decals that becomes damaged or illegible. Part numbers for decals are listed below and in your Parts Catalog. Order replacements from your Authorized Toro Distributor.

## IMPORTANT

**CHECK PTO LENGTH  
BEFORE INSTALLATION**

**DO NOT RAISE  
EQUIPMENT MORE THAN  
15° FROM HORIZONTAL  
OR DAMAGE MAY  
RESULT TO PTO**

**MAX. INPUT SPEED  
540 RPM**

01-506-0160

FRONT OF HOOD-R.H. SIDE  
(Part No. 01-506-0160)



NEAR BEARINGS, ON WHEEL  
YOKES & CHAIN GUARD  
(Part No. 01-506-0550)

## **⚠ WARNING**

DISCHARGED AIR HAS CONSIDERABLE  
FORCE AND COULD CAUSE INJURY OR  
LOSS OF FOOTING

- STAY AWAY FROM DISCHARGE OPENING WHEN MACHINE IS RUNNING.
- KEEP BYSTANDERS AWAY FROM DISCHARGE OPENING WHEN MACHINE IS RUNNING.

01-506-0110

LOWER HOUSING-L.H. SIDE  
(Part No. 01-506-0110)

## **⚠ DANGER**

ROTATING CHAINS AND SPROCKETS CAN  
CAUSE SERIOUS PERSONAL INJURY

DO NOT OPERATE MACHINE UNLESS ALL  
GUARDS ARE IN PLACE

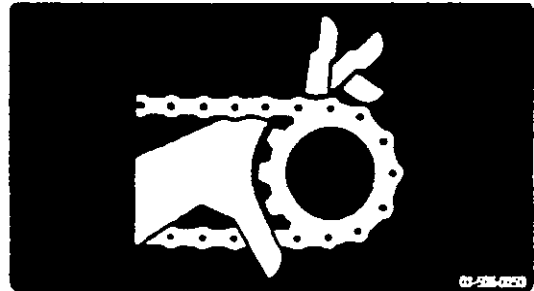

01-506-0050

ON CHAIN GUARD  
(Part No. 01-506-0050)

# NO RIDERS

75-8180

ON HITCH FRAME  
(Part No. 01-506-0540)



## **⚠ DANGER**

ROTATING MEMBERS CAN CAUSE PERSONAL INJURY.  
DO NOT OPERATE UNLESS SHIELD IS IN PLACE.

01-506-0130

CENTER FRAME BRACE  
(Part No. 01-506-0130)

# SPECIFICATIONS

**HITCH:** Standard 3 point hitch

**POWER:** Tractor PTO drive at 540-600 RPM  
(PTO has torque limiter)

**FRAME:** All welded steel construction

**GEAR & CHAIN BOX:**  
D50 chain and sprockets.  
Runs in grease.

**BEARINGS:** Self sealed, self aligned

**IMPELLER SHAFT:** High carbon steel, 2"  
diameter reduced to 1 1/2" at ends

**IMPELLER:**  
12 bladed. reinforced, 36" diameter,  
welded and balanced

**WHEELS:** Castor type

**TIRES:** Pneumatic (2), 4.10 x 3.50-6, 2 ply  
(40 PSI)

**AIR MOVEMENT:**  
144 MPH @ 1100 RPM (540 PTO)  
660 CFM @ 1100 RPM (540 PTO)

**SKIDS:** Steel, welded to housing, protector bars

**DIRECTIONAL CHUTE:**  
Optional, all steel, over center locking,  
spring tension control, operated from  
tractor seat

**DIMENSIONS:** Width - 50"  
Length - 49"  
Height - 44"

# BEFORE OPERATING

## ATTACH BLOWER TO TRACTOR

**IMPORTANT:** The maximum PTO speed is 540 RPM. Do not operate at a faster speed because the fan, sprockets and PTO will be damaged.

1. Connect the PTO half (1 3/8" splined slip clutch) to the tractor. When new, the spring lock lever on the end of the PTO is hard to operate. Apply grease and work the lever until it snaps in and out freely. In the correct position the lever will spring back out and lock the two shafts together.



### CAUTION

The spring lever must be locked into position before operating. Failure to lock the spring lever will result in the PTO disconnecting from the tractor.

2. Lower the three point hitch arms on the tractor.
3. Position the blower so that the three point hitch arms of the tractor line up with the main arms of the blower.
4. Connect the two halves of the PTO and slowly slide the blower toward the tractor.
5. Line up the three point arms and the stabilizer arm of the tractor with the blower. Secure all arms with the tractor hardware.
6. Slowly, lower and raise the blower to check the PTO length and proper ground clearance. Measure the distance from the bottom of the blower to the ground. It should be between 14" and 22". On some tractors it may be necessary to shorten the PTO shaft. To shorten:

A. Lift the blower until the two halves are fully contracted. Determine how much needs to be cut off to raise the blower to the proper ground clearance.

B. Remove the tractor PTO half from the implement half.

C. Cut the pre-determined amount off with a hand saw.

D. Replace the PTO half on the tractor. Lock the spring lever into place.

E. Lift the blower up and re-check PTO length.

F. Repeat steps B through D if the PTO length is still too long.

## CHECK TIRE PRESSURE

Check tire pressure before each use. Inflate to 40 PSI. Failure to maintain 40 PSI could result in the tire breaking loose from the rim.

## CASTOR WHEELS (Fig. 1)

When the three point lift is lowered and the castor wheels do not touch the ground, the wheels need to be adjusted. To adjust:

A. Remove the roll pin (A) and allow the wheel to drop from the mounting bracket.

B. Move the top spacers (B) to the bottom of the yoke mounting bracket.

C. Replace the roll pin.

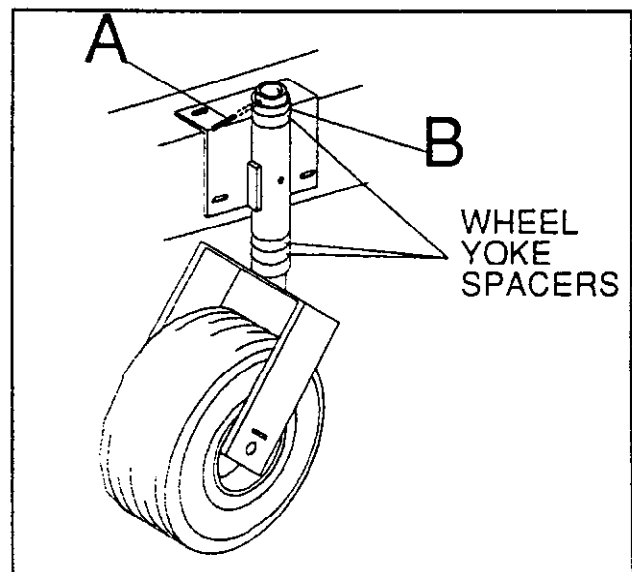

Figure 1

# OPERATING INSTRUCTIONS

**IMPORTANT:** The maximum PTO speed is 540 RPM. Do not operate at a faster speed because the fan, sprockets and PTO will be damaged.

1. Start tractor engine and run at a low RPM. Slowly engage the PTO.

**IMPORTANT:** If the tractor does not have a two stage clutch or live PTO, engage the clutch slowly to prevent stalling of the engine. When stopping or turning, allow yourself some extra distance, as the impeller takes a few moments to stop and will continue to power the rear tires of the tractor.

2. Run tractor engine to 1100 RPM.

3. Practice blowing material. It is advisable to blow the same direction the wind is blowing to prevent material from blowing back into the cleared area.



## WARNING

**DISCHARGED AIR HAS CONSIDERABLE FORCE AND COULD CAUSE INJURY OR LOSS OF FOOTING**

- Stay away from discharge opening when machine is running.
- Keep bystanders away from discharge opening when machine is running.

4. The PTO has a ratchet type torque limiter on the implement end to limit the shock load on the chain, sprockets and fan upon initial start up. If the torque limiter ratchets, it is necessary to disengage the PTO to prevent wear.

**IMPORTANT:** Do not raise the blower more than 15 degrees above the horizontal position because the PTO may be damaged.

# LUBRICATION

## BEARINGS (Fig. 2)

The blower has four self sealing bearings that must be lubricated with a No. 2 Lithium based grease.

**IMPORTANT:** Lubricate the bearings to maintain a slight leakage on the seals. Too much grease can cause overheating.

## WHEELS AND WHEEL BEARINGS (Fig. 2)

Grease fittings weekly or every 40 operating hours. Use a No. 2 Lithium based grease.

## DRIVE CHAIN (Fig. 2)

1. Always maintain a heavy coat of grease on the drive chain. Turn PTO by hand while lubricating to obtain distribution of grease along chain.

## PTO (Fig. 2)

1. Grease the PTO fittings weekly or every 40 operating hours. Use a No. 2 Lithium based grease.

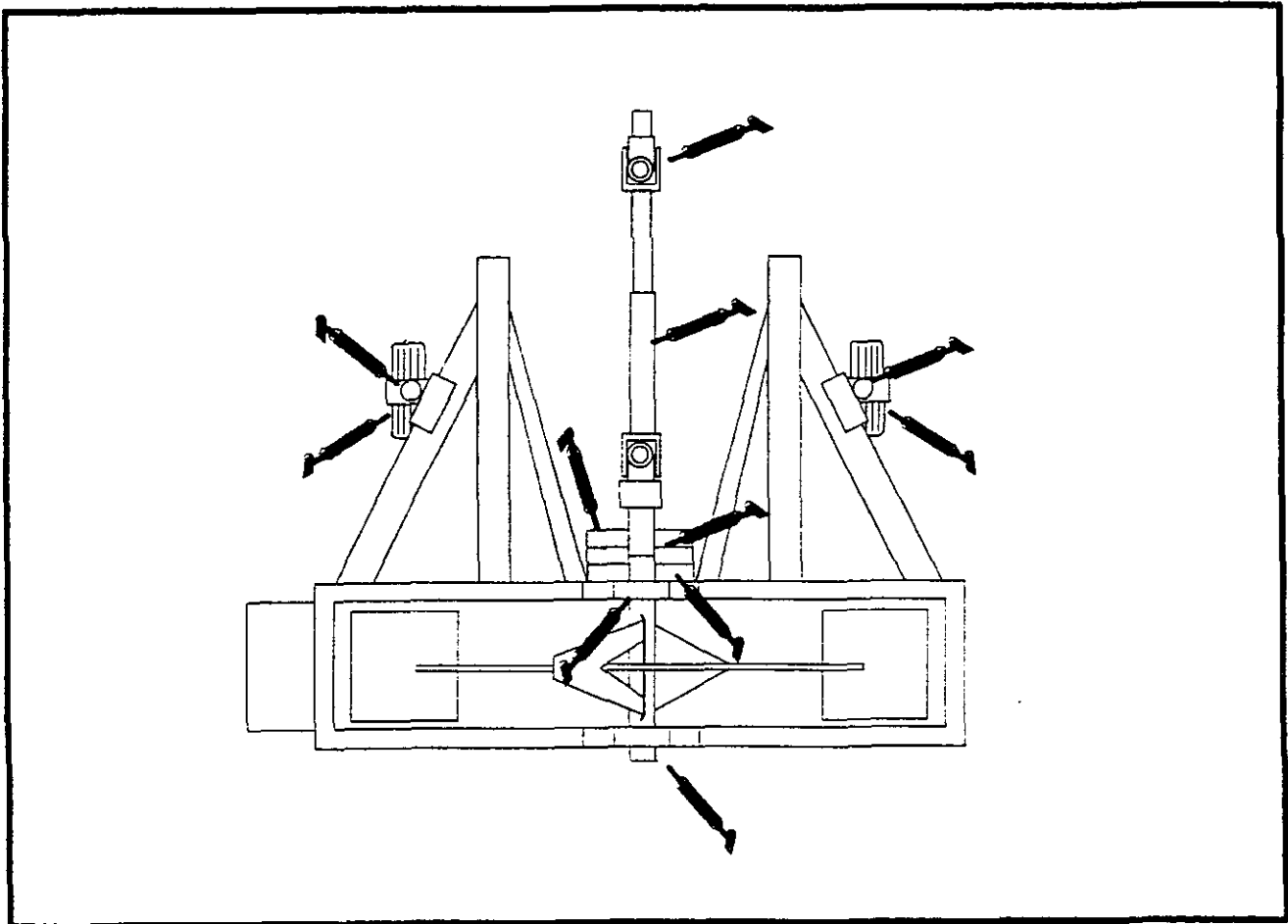

Figure 2

# MAINTENANCE

## DRIVE CHAIN ADJUSTMENT (Fig. 3)

The drive chain is adjusted to allow a 1/8" deflection with 5 lbs of force. Do not over tighten the chain because it will wear rapidly. If chain is too loose, the sprocket will wear.

To adjust the drive chain:

- A. Loosen the four bolts (A).
- B. Loosen the nut on the bolt (B).
- C. Turn the bolt to adjust. Turn clockwise to tighten, counterclockwise to loosen.
- D. Tighten the four bolts (A), and the nut (B).

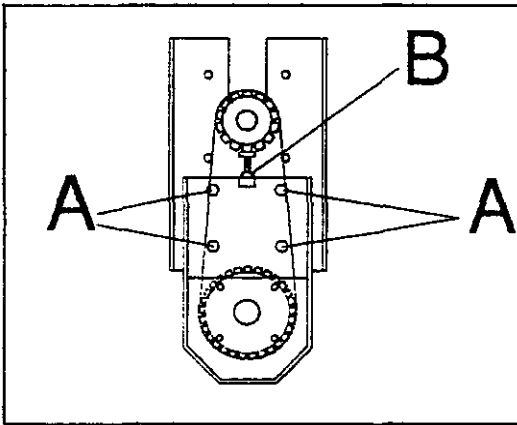

Figure 3

## PTO DRIVE MAINTENANCE

1. The PTO has a ratchet type torque limiter on the implement end to limit the shock load on the chain, sprockets and fan upon initial start up. If the torque limiter ratchets, it is necessary to disengage the PTO to prevent wear. After disengaging and the PTO has come to a complete stop, assure the tractor RPM is low and then the PTO can be engaged again and operation continued.

## BLOWER FAN MAINTENANCE

The fan and fan blades must be kept clean. Material build-up on fan blades may throw the unit out of balance. Operating the fan out of balance will result in vibration, leading to premature component wear. Diesel tractors and rear exhaust tractors may cause a more rapid build-up. Inspect fan regularly and clean as necessary (i.e.; powerwash).

## TROUBLE SHOOTING

CONDITION	CAUSE	CORRECTION
<p><b>FAN QUIT TURNING</b></p>	<ul style="list-style-type: none"> <li>• Remove Chain Guard. Check for broken or loose chain.</li> <li>• Check the PTO for a sheared bolt.</li> <li>• Check the drive shaft. A key may be sheared on the sprocket.</li> </ul>	<ul style="list-style-type: none"> <li>• Replace chain or adjust the chain tension. (See Drive Chain Adjustment)</li> <li>• Replace the bolt.</li> <li>• Replace key.</li> </ul>
<p><b>EXCESSIVE VIBRATION</b></p>	<ul style="list-style-type: none"> <li>• Check bearings on fan shaft for damage.</li> <li>• Look into deflector opening of deflector, check for material build up on fan blades.</li> <li>• RPM of the PTO shaft too fast</li> </ul>	<ul style="list-style-type: none"> <li>• Replace bearings.</li> <li>• Clean off any build-up inside the housing.</li> <li>• Reduce PTO speed to 540 RPM.</li> </ul>
<p><b>LACK OF ADEQUATE AIR FLOW</b></p>	<ul style="list-style-type: none"> <li>• Check air slots on back and front housings. Slots may be clogged with debris.</li> <li>• RPM on tractor too slow.</li> <li>• Throttle on the tractor engine may be too slow.</li> </ul>	<ul style="list-style-type: none"> <li>• Clean out any debris from slots.</li> <li>• Bring PTO speed to 540 RPM.</li> <li>• Make any necessary repairs to bring tractor speed up to normal.</li> </ul>

## STORAGE

1. Thoroughly clean the blower. The fan housing should be free of dirt, leaves and debris. Power wash the fan and fan blades. (See Maintenance).
2. Inflate tires to 40 PSI.
3. Check all fasteners for looseness: tighten as necessary.
4. Grease or oil all grease fittings and bearings. Wipe off excess lubricant. (See Lubrication).
5. Check the tension and condition of the drive chain. Adjust the tension if necessary and lightly coat the chain with grease. Fill the gearbox with hand gun grease.

## IDENTIFICATION AND ORDERING

### MODEL AND SERIAL NUMBER

The DEBRIS BLOWER 2613 has two identification numbers: a model and serial number. The two numbers are stamped on a plate which is riveted to the main arm. In any correspondence concerning the Debris Blower 2613, supply model and serial numbers to be sure that the correct information and replacement parts are obtained.

To order replacement parts from an authorized TORO Distributor, supply the following information.

1. Model and serial numbers of the machine.
2. Part number, description and quantity of parts desired.

**Note:** Do not order by reference number if a parts catalog is being used; use the part number.

# NOTES

# NOTES



# The Toro Promise

## A ONE YEAR LIMITED WARRANTY

*The Toro Company promises to repair your TORO Product if defective in materials or workmanship. The following time periods from the date of purchase apply:*

**Commercial Products ..... 1 Year**

*The costs of parts and labor are included, but the customer pays the transportation costs on walk rotary mowers with cutting widths of less than 25".*

If you feel your TORO product is defective and wish to rely on The Toro Promise, the following procedure is recommended:

1. Contact your Authorized TORO Distributor or Commercial Dealer (the Yellow Pages of your telephone directory is a good reference source).
2. The TORO Distributor or Commercial Dealer will advise you on the arrangements that can be made to inspect and repair your product.
3. The TORO Distributor or Commercial Dealer will inspect the product and advise you whether the product is defective and, if so, make all repairs necessary to correct the defect without an extra charge to you.

If for any reason you are dissatisfied with the distributor's analysis of the defect or the service performed, you may contact us.

Write:

TORO Commercial Products Service Department  
100 Industrial Parkway  
Industrial Airport, Ks. 66031

The above remedy of the product defects through repair by an Authorized TORO Distributor or Commercial Dealer is the purchaser's sole remedy for any defect.

THERE IS NO OTHER EXPRESS WARRANTY. ALL IMPLIED WARRANTIES OF MERCHANTABILITY AND FITNESS FOR USE ARE LIMITED TO THE DURATION OF THE EXPRESS WARRANTY.

Some states do not allow limitations on how long an implied warranty lasts, so the above limitation may not apply to you.

This Warranty applies only to parts or components which are defective and does not cover repairs necessary due to normal wear, misuse, accidents, or lack of proper maintenance. Regular, routine maintenance of the unit to keep it in proper condition is the responsibility of the owner.

All warranty repairs reimbursable under the Toro Promise must be performed by an Authorized TORO Commercial Dealer or Distributor using Toro approved replacement parts.

Repairs or attempted repairs by anyone other than an Authorized TORO Distributor or Commercial Dealer are not reimbursable under the Toro Promise. In addition, these unauthorized repair attempts may result in additional malfunctions, the correction of which is not covered by warranty.

THE TORO COMPANY IS NOT LIABLE FOR INDIRECT, INCIDENTAL OR CONSEQUENTIAL DAMAGES IN CONNECTION WITH THE USE OF THE PRODUCT INCLUDING ANY COST OR EXPENSE OF PROVIDING SUBSTITUTE EQUIPMENT OR SERVICE DURING PERIODS OF MALFUNCTION OR NON-USE.

Some states do not allow the exclusion or limitation of incidental or consequential damages, so the above limitation or exclusion may not apply to you.

This warranty gives you specific legal rights, and you may also have other rights which vary from state to state.

### COUNTRIES OTHER THAN THE UNITED STATES OR CANADA

Customers who have purchased TORO products exported from the United States or Canada should contact their TORO Distributor (Dealer) to obtain guarantee policies for your country, province or state. If for any reason you

are dissatisfied with your Distributor's service or have difficulty obtaining guarantee information, contact the TORO importer. If all other remedies fail, you may contact us at The Toro Company.