

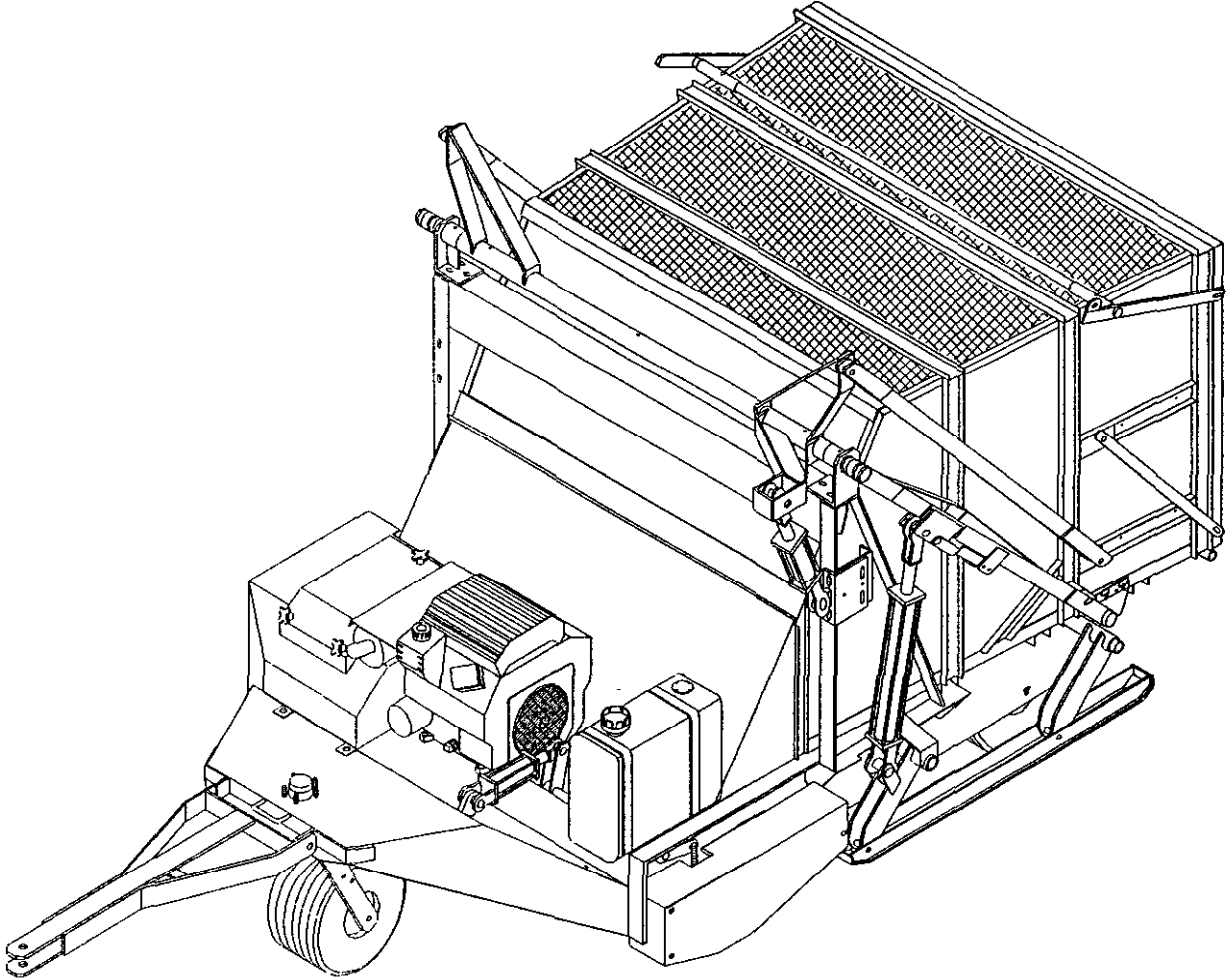

MODEL NO. 44089 - 30001 & UP

OPERATOR'S
MANUAL

TURF SWEEPER 1655HL



FOREWORD

Thank you for buying a high quality Toro turf care product. To get the best performance from this machine, operate and maintain it according to the instructions in this manual.

Toro also wants to stress the importance of safety. You and anyone else using or maintaining this machine are strongly urged to read this manual, especially all the safety instructions.

DANGER, WARNING and CAUTION, used with the triangular safety alert symbol, highlight safety messages. Always read and understand these messages because they relate to personal injury and your safety.

If you ever need help or have questions about your new Toro turf care product, contact your local Authorized Toro Distributor. The Toro Distributor has a complete supply of replacement parts, a full line of accessories and a professional service staff to support you. Keep your Toro all Toro. Buy genuine Toro parts and accessories.

TABLE OF CONTENTS

	Page		Page
SAFETY INSTRUCTIONS	3 - 5	CHAIN TENSION	13
SAFETY AND INSTRUCTION DECALS	6	SWEeper REELS LEVELING & HEIGHT ADJUSTMENT	13
SPECIFICATIONS	7	DRIVE BELT ADJUSTMENT	13
BEFORE OPERATING		BELT TENSION	13
FILL FUEL TANK	8	BELT STOP PIN ADJUSTMENTS	14
CHECK HYDRAULIC SYSTEM OIL	8	HYDRAULIC SCHEMATIC - 1655HL	15
CONTROLS	9	WIRING DIAGRAM - 1655HL	16
OPERATING INSTRUCTIONS	10	TROUBLE SHOOTING	17
LUBRICATION	11	STORAGE	18
MAINTENANCE	12 - 14	IDENTIFICATION AND ORDERING	18
CHANGING HYDRAULIC OIL & FILTER	12	MAINTENANCE CHART	19
CHECKING HYDRAULIC LINES & HOSES ...	12	THE TORO PROMISE	Back Cover
TIMING CHAIN MAINTENANCE	12		

SAFETY INSTRUCTIONS



The safety alert symbol means **CAUTION, WARNING or DANGER** - "personal safety instruction". Read and understand the instruction because it has to do with safety. Failure to comply with the instruction may result in personal injury.

BEFORE OPERATING

1. Read and understand the contents of this manual before starting and operating the machine. Become familiar with all controls and know how to stop quickly. A free replacement manual is available by sending complete Model and Serial Number to:

The Toro Company
8111 Lyndale Avenue South
Minneapolis, Minnesota 55420

2. **Do Not** allow children to operate the machine. Do not allow adults to operate the machine without proper instruction.

3. **Never** operate the machine while under the influence of drugs or alcohol.

4. Keep all shields and safety devices in place. If a shield, safety device or decal becomes damaged, malfunctioning or illegible, repair or replace it before operation is commenced. Also tighten loose nuts, bolts to ensure machine is in safe operating condition.

5. Before each use, tighten all bolts and nuts.

6. Do Not alter this equipment in any manner which may cause hazardous conditions.

7. Fill gas tank before starting the engine. Avoid spilling any gas. Since gas is flammable, handle it carefully.

A. Use a approved fuel container.

B. **Do Not** fill tank when engine is hot or running.

C. **Do Not** smoke while handling fuel.

D. Fill tank outdoors and up to about one inch (25 mm) from the top of the tank.

E. Wipe up any spilled fuel.

SAFETY INSTRUCTIONS (Continued)

WHILE OPERATING



DANGER

ROTATING MEMBERS CAN CAUSE SERIOUS PERSONAL INJURY

- Keep hands and feet away from reel area.

8. Sit on towing vehicle seat when operating machine.

9. **Do Not** run the engine in a confined area without adequate ventilation. Exhaust fumes are hazardous and could possibly be deadly.

10. **Do Not** touch engine or muffler while engine is running or soon after it is stopped. These areas could be hot enough to cause a burn.

11. Using the machine demands attention, and to prevent loss of control:

A. Operate only in daylight or when there is good artificial light.

B. Drive slowly.

C. Watch for holes or other hazards.

D. Look behind machine before backing up.

E. **Do Not** drive close to a sand trap, ditch, creek or other hazard.

F. Reduce speed when making sharp turns and when turning on a hillside.

G. Avoid sudden stops and starts.

12. Operator must be skilled and trained in how to drive on hillsides. Failure to use caution on slopes or hills may cause loss of control possibly resulting in personal injury or death.

13. If engine of the towing vehicle stalls or machine loses headway and cannot make it to the top of a slope, do not turn machine around. Always back slowly



DANGER

MOVING HOPPER AND DUMPED DEBRIS CAN CAUSE SERIOUS PERSONAL INJURY

- Stay clear of hopper while machine is backing or dumping.
- Stay clear of moving parts while hopper is moving up or down

WHILE DUMPING

14. **NEVER** operate hopper controls while standing beside machine.

15. Keep bystanders a safe distance from hopper when dumping debris. Use care when backing machine.

16. Dump hopper only in area clear of overhead wires and other obstructions.

17. **NEVER** dump hopper on a slope. Always dump hopper on level ground.

SAFETY INSTRUCTIONS (Continued)

MAINTENANCE

18. Remove the key from the ignition switch to prevent accidental starting of the engine when servicing, adjusting or storing the machine.
19. If major repairs are ever needed or assistance desired, contact an Authorized TORO Distributor.
20. Make sure machine is in safe operating condition by keeping nuts, bolts and screws tight.
21. To reduce potential fire hazard, keep the engine free of excessive grease, grass, leaves and accumulations of dirt.
22. Make sure all hydraulic line connectors are tight, and all hydraulic hoses and lines are in good condition before applying pressure to the system.

23. Keep body and hands away from pin hole leaks or nozzles that eject hydraulic fluid under high pressure. Use paper or cardboard, not hands, to search for leaks. Hydraulic fluid escaping under pressure can have sufficient force to penetrate skin and do serious damage. If fluid is injected into the skin it must be surgically removed within a few hours by a doctor familiar with this form of injury or gangrene may result.

24. **Do Not** over speed the engine by changing the governor settings. Maximum engine speed with no load is 3200 RPM. To ensure safety and accuracy, have an Authorized TORO Distributor check maximum engine speed with a tachometer.

25. Engine must be shut off before checking oil or adding oil to the crankcase.

SAFETY AND INSTRUCTION DECALS

The following safety and instruction decals are installed on the unit. Replace any decals that becomes damaged or illegible. Part numbers for decals are listed below and in your Parts Catalog. Order replacements from your Authorized Toro Distributor.



ON MAIN FRAME
(Part No. 01-506-1150)

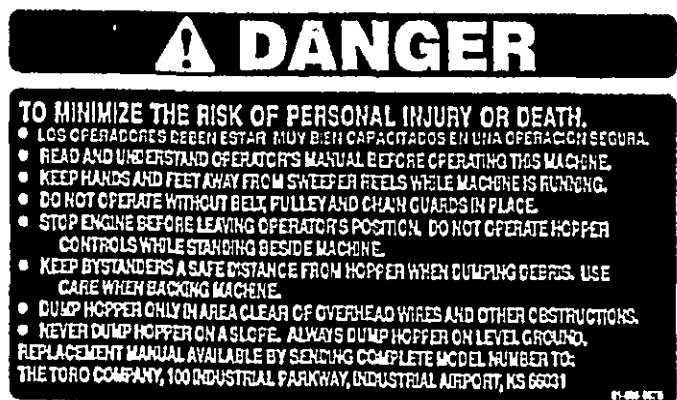

ON MAIN FRAME
(Part No. 01-506-0070)

SAFETY AND INSTRUCTION DECALS



⚠ DANGER
 ROTATING MEMBERS CAN
 CAUSE SERIOUS PERSONAL
 INJURY
 • KEEP HANDS AND FEET AWAY
 FROM REEL AREA. 01-506-0080

⚠ DANGER
 TO AVOID FIRE HAZARD:
 • KEEP LEAVES, GRASS AND
 OTHER COMBUSTABLE MATERIAL
 AWAY FROM HOT ENGINE MUFFLER. 01-506-0030

EACH SIDE BY REELS
 (Part No. 01-506-0080)

ON ENGINE
 (Part No. 01-506-0030)

⚠ DANGER

• ROTATING PULLEYS AND BELTS CAN CAUSE
 SERIOUS INJURY.
 • DO NOT OPERATE MACHINE UNLESS ALL
 GUARDS ARE IN PLACE.



ON BELT GUARD
 (Part No. 01-506-0040)

⚠ DANGER

ROTATING CHAINS AND SPROCKETS CAN
 CAUSE SERIOUS PERSONAL INJURY
 DO NOT OPERATE MACHINE UNLESS ALL
 GUARDS ARE IN PLACE



ON CHAIN GUARD
 (Part No. 01-506-0050)



ON HYDRAULIC PUMP
 (Part No. 52-9640)



ON GAS TANK
 (Part No. 71-3730)

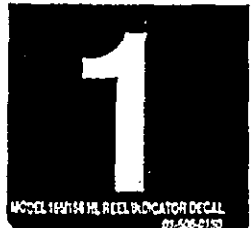

LINED UP WITH REEL
 POINTER
 (Part No. 01-506-0150)



NEAR BEARINGS &
 GREASE POINTS
 (Part No. 58-6520)

SPECIFICATIONS

SWEEPING WIDTH: 60" (5 feet)

ENGINE: 18 HP Kohler, OHV Command (3000 RPM)

FRAME: All welded steel construction

PICK UP FINGERS: Abrasion resistant, high resistance rubber, 140 per machine.

PICK UP: Mechanical, 2 reels, timed, counter rotating, with "Sure Grip" rubber fingers.

HOPPER: 5 cubic yards.

DUMP: Hydraulic, 9' Height

BEARINGS: Self sealed throughout

DRIVE TO REEL: Belt

TIRES: Front & Rear - 18.00 x 8.5 - 8 (22 PSI)

DIMENSIONS: Width - 81" (205 cm)
Length - 128" (325 cm)
Height - 77 " (195 cm)

REEL HEIGHT ADJUSTMENT: Electric hydraulic to reels that pivot, positive adjustment from operator's seat.

SHIPPING WEIGHT : 2900 lbs.

OPTIONS: Throttle Whisper Switch, Thatcher, Donaldson Air Cleaner Kit, Rubber Finger Puller.

BEFORE OPERATING

FILL FUEL TANK WITH GASOLINE (Fig. 1)

THE TORO COMPANY STRONGLY RECOMMENDS THE USE OF FRESH CLEAN, UNLEADED REGULAR GRADE GASOLINE IN TORO GASOLINE POWERED PRODUCTS. UNLEADED GASOLINE BURNS CLEANER, EXTENDS LIFE, AND PROMOTES GOOD STARTING BY REDUCING THE BUILD-UP OF COMBUSTION CHAMBER DEPOSITS.

Note: Do Not mix oil with gasoline. Never use methanol, gasoline containing methanol, gasohol, gasoline additives, premium gasoline, or white gas because engine/fuel system damage could result.

DANGER

Because gasoline is flammable, caution must be used when storing or handling it. Do not fill fuel tank while engine is running, hot or when machine is in an enclosed area. Vapors may build up and be ignited by a spark or flame source many feet away. **DO NOT SMOKE** while filling the fuel tank to prevent possibility of explosion. Always fill fuel tank outside and wipe up any spilled gasoline before starting engine. Use a funnel or spout to prevent spilling gasoline before starting engine and fill tank to about 1 inch (25 mm) below the filler neck. Store gasoline in a clean safety approved container and keep the cap in place on the container. Keep gasoline in a cool, well ventilated place; never in an enclosed area such as a hot storage shed. To assure volatility, do not buy more than a 30 day supply of gasoline.

Gasoline is a fuel for internal combustion engines; therefore, do not use it for any other purpose. Since many children like the smell of gas, keep it out of their reach because the fumes are explosive and dangerous to inhale.

1. Remove the cap from the fuel tank and fill the 5 gallon tank to within 1 inch (25 mm) from the top with unleaded gasoline. Install fuel cap tightly.
2. Wipe up any gasoline that may have spilled to prevent a fire hazard.

CHECK HYDRAULIC SYSTEM OIL (Fig. 1)

The hydraulic system is designed to operate on any high quality detergent. Oil recommendations are: 10W30 SF-CC

1. Position the sweeper on a level surface and make sure engine is off.
2. Pull out the dipstick from the oil filler tube. Check the level indicated on the dipstick.
3. If low, add sufficient oil to bring to the "Full" mark. Do Not overfill.

IMPORTANT: When adding oil to the hydraulic system, use a funnel with a fine screen - 200 mesh - and ensure funnel and oil are immaculately clean. This procedure prevents accidental contamination of the hydraulic system which will damage the hydraulic system.

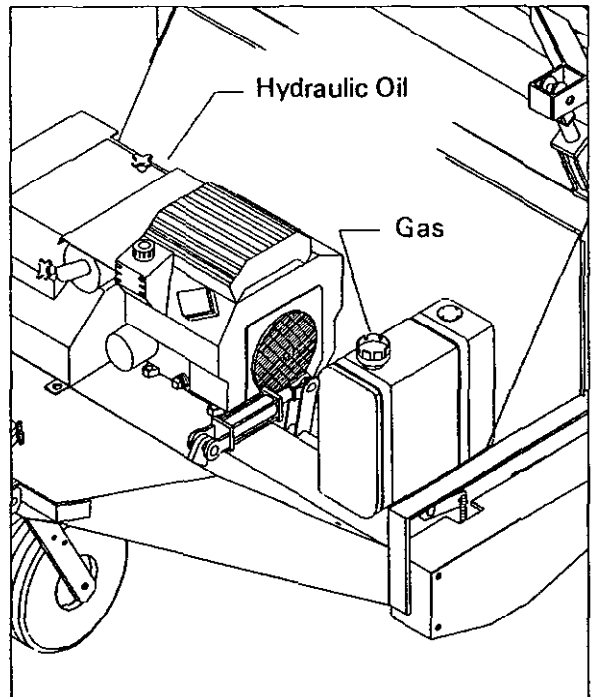

Figure 1

CHECK TIRE PRESSURE

Check tire pressure before each use. Inflate to 22 PSI.

CONTROLS

OPTIONAL THROTTLE CONTROL SWITCH (Fig. 2)

Throttle is used to operate engine at various speeds. Moving switch upward increases engine speed; downward decreases engine speed.

KEY SWITCH

The key switch, which is used to start and stop the engine, has two positions: "OFF" and "ON". Rotate key clockwise to engage starter motor. When engine starts, release key and it will move automatically to the "ON" position. To shut engine off, rotate key counterclockwise

REEL ENGAGEMENT SWITCH (Fig. 2)

The finger reels are engaged by the electric switch located on the Control Box. Push the switch forward to raise the reels and push switch downward

to lower and engage the reels.

HOPPER TILT SWITCH (Fig. 2)

The electric switch controls the hydraulics to tilt the hopper which opens the door. Push the switch downward to close the hopper and push it upward to open the hopper for dumping.

HOPPER LIFT SWITCH (Fig. 2)

The electric switch controls the hydraulics to lift the hopper up and down. Push the switch upward to raise the hopper and push it downward to lower the hopper.

OPTIONAL THATCHER SWITCH (Fig. 2)

The electric switch controls the hydraulics to raise and lower the optional thatcher. Push the switch upward to raise and push it downward to lower.

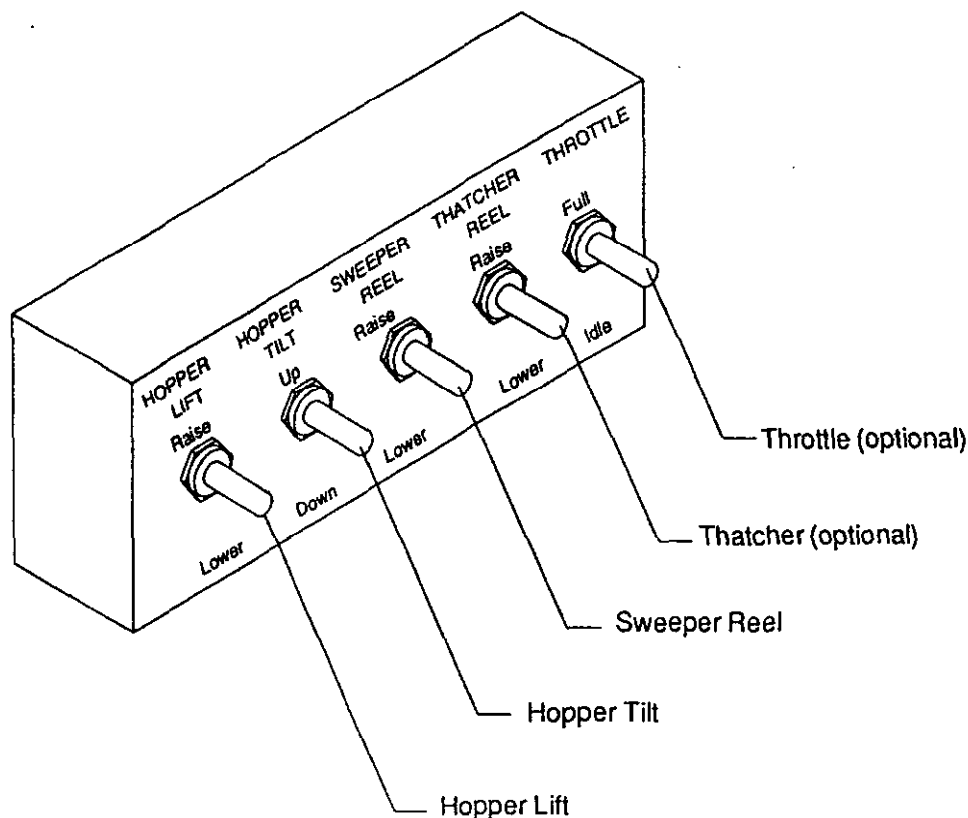



Figure 2

OPERATING INSTRUCTIONS

1. Place the unit on a level surface and apply the parking brake of the towing vehicle.
2. Start engine with the throttle at 1/2 open and choke pulled out. When engine starts, push in the choke gradually.
3. Run engine to 3/4 or full throttle.
4. As you are moving forward engage the Sweeper Reel engagement switch on the Control Box to engage the finger reels.

IMPORTANT: NEVER run the reels in one spot for longer than a minute because turf will be damaged.

WHILE SWEEPING

 DANGER
TIP OVER CAN CAUSE SERIOUS INJURY OR DEATH
Never operate on steep slopes.
Sweep slopes up and down, never across the face.
When going uphill or downhill, do not stop or start suddenly.
Stay alert for holes in the terrain or other hidden hazards. To avoid tipping or loss of control, do not drive close to a ditch, creek or drop off.
If machine stops going uphill, disengage reels and back slowly downhill. Do not attempt to turn.

1. When the hopper is full, disengage reels and transport to dumping area. When the hopper is full the sweeper will no longer pickup as efficiently, leaving or throwing material back on the ground.

DUMPING THE HOPPER

 DANGER
TO MINIMIZE THE RISK OF PERSONAL INJURY OR DEATH
Never dump hopper on a slope. Always dump hopper on level ground.
Dump only in area clear of overhead wires and other obstructions.
Do not operate hopper controls while standing beside machine.

1. Engage the hopper lift switch on the Control Box to lift the hopper.
2. Engage the hopper tilt switch on the Control Box to empty.
3. When hopper is empty return the hopper to sweeping position using the electric switch on the Control Box.

LUBRICATION

BEARINGS (Fig. 3)

The sweeper has five self sealing bearings that must be lubricated with a No. 2 Lithium based grease.

IMPORTANT: Lubricate the bearings as often as necessary to maintain a slight leakage on the seals. Too much grease can cause overheating.

WHEELS AND WHEEL BEARINGS (Fig. 3)

Grease fittings and wheel bearings every 100 operating hours. Use a No. 2 Lithium based grease.

DRIVE CHAIN (Fig. 3)

Always maintain a heavy coat of grease on the drive chain.

GREASE FITTINGS (Fig. 3)

There are thirteen grease fittings that must be lubricated with a No. 2 Lithium based grease. Grease fittings every 100 hours of operation or as needed to maintain a slight leakage at the points.

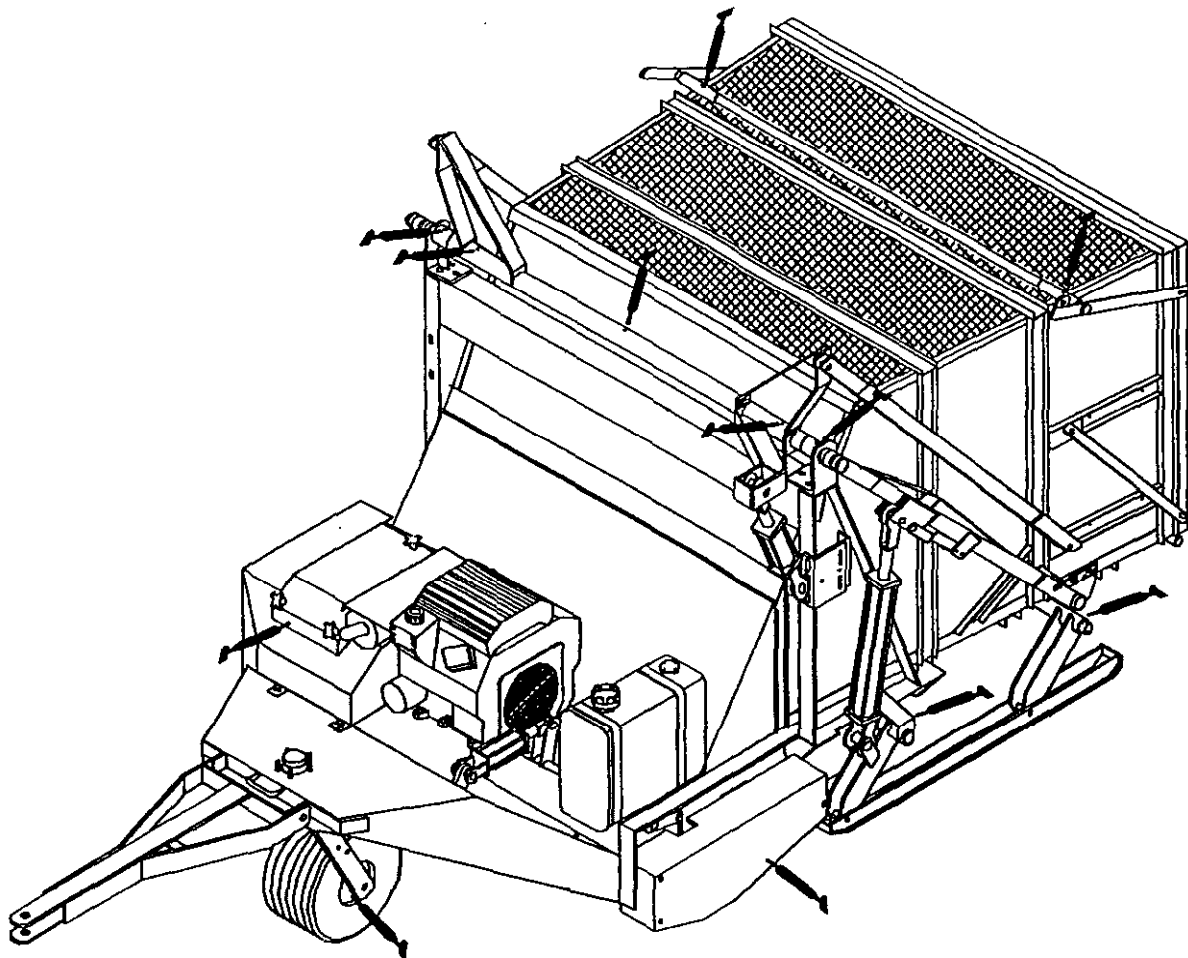

Figure 3

MAINTENANCE

CHANGING HYDRAULIC

Normally, change hydraulic oil after every 500 operating hours. If oil becomes contaminated, contact your local TORO Distributor because the system must be flushed. Contaminated oil looks milky or black when compared to clean oil.

1. Remove the belt guard.
2. Loosen the bolts on the bearing.
3. Remove the belt on the pump pulley.
4. At the valve bank, check the stampings on the valves for the OUT and IN ports. Remove the hydraulic hose on the IN port and place in a container to collect dirty oil.
5. Hand turn the pulley on the pump shaft until fluid is empty or is blowing air.
6. Reconnect the hydraulic hose to the valve.
7. Install the belt and tighten bearing bolts.
8. Install belt guard.
9. Fill the pump with 10W30 SF-CC oil until the level is 1" from the top of the reservoir.
10. Start the engine and run it at idle for 3 to 5 minutes to circulate the fluid and remove any air trapped in the system. Operate the hopper door and hopper lift valve control. Stop the engine and re-check the fluid level.

CHECKING HYDRAULIC LINES AND HOSES

After every 100 operating hours, check hydraulic lines and hoses for leaks, kinked lines, loose mounting supports, wear, loose fittings, weather deterioration and chemical deterioration. Make all necessary repairs before operating.



WARNING

Keep body and hands away from pin hole leaks or nozzles that eject high pressure hydraulic fluid. Use a cardboard or paper to find hydraulic leaks. Hydraulic fluid escaping under pressure can penetrate skin and cause injury. Fluid accidentally injected into the skin must be surgically removed within a few hours by a doctor familiar with this form of injury or gangrene may result.

TIMING CHAIN MAINTENANCE (Fig. 4)

To prevent the fingers from hitting each other, reels should be set at a 45 degree position from each other.

1. Remove the chain guard.
2. Remove the connecting link from the chain.
3. Rotate the rear reel by hand until the reel is positioned as shown below.
4. Install the connecting link on the chain.
5. Install chain guard.

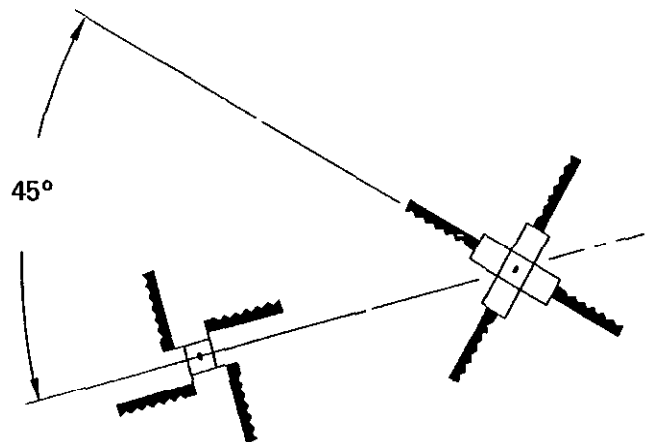

Figure 4

MAINTENANCE (Continued)

CHAIN TENSION (Fig. 5)

The rear idler sprocket is under spring tension to keep a constant tension on the reel drive chain. To increase tension, screw jam nut (A) clockwise, to decrease, turn counterclockwise. A 1/8" deflection is recommended. Do not over tighten because the chain will wear rapidly. Do not operate with a loose chain because the sprocket will wear rapidly.

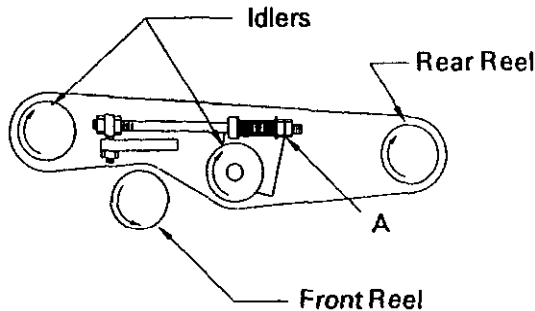

Figure 5

SWEEPER REELS LEVELING & HEIGHT ADJUSTMENT (Fig. 6)

The sweeper reels should be parallel with the bottom of the sweeper to maintain an even distance from the ground. The reels are set at 2-1/8" from ground level on both sides. This setting is standard and when lowered to ON position will accommodate most types of grasses. If the dimension is different or not correct from end to end, the nuts (A) may be used to correct it.

IMPORTANT: After leveling sweeper reels, always check the tension of the reels drive belt for proper adjustment. See Drive Belt Adjustment.

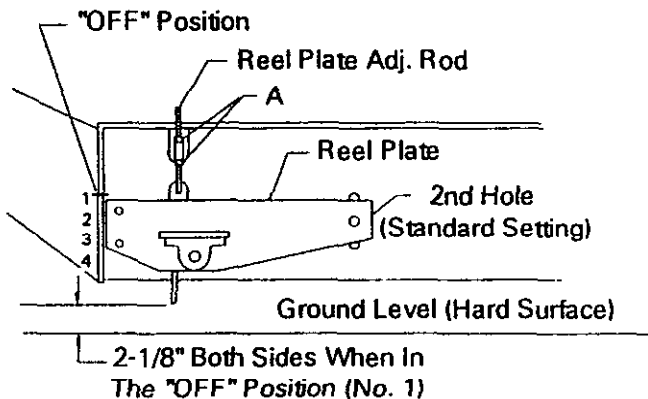

Figure 6

DRIVE BELT ADJUSTMENT (Fig. 7)

If Reels Fail To Engage: Adjust the idler disengaging bolt downward. The adjustment may be necessary from time to time to compensate for wear and stretch on the drive belt.

If Reels Fail To Disengage: Adjust the idler disengaging bolt upward to move the idler pulley away from the drive belt.

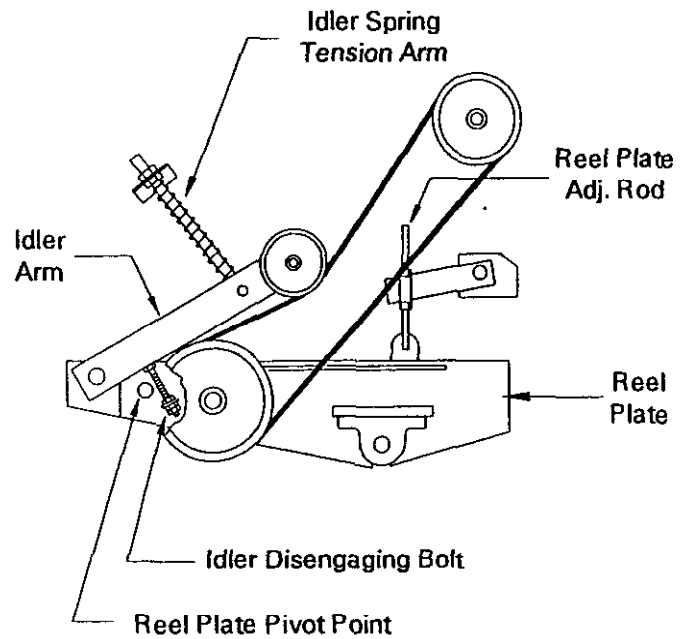

Figure 7

BELT TENSION (Fig. 7)

The belt has 1/4" deflection with 5 lbs. of force when properly adjusted. To decrease tension, move the idler spring upward; downward to increase tension.

MAINTENANCE (Continued)

BELT STOP PIN ADJUSTMENTS (Fig. 8)

The purpose of the belt stop pins is to slow down and stop the drive belt when the Sweeper Reel lever is disengaged. Pin adjustments are maintained as follows:

1. With the engine off and key removed from ignition, place the Sweeper Reel Lever in the first (ON) position.
2. Loosen the nut on the back of the pin.
3. Adjust the belt stop pins so they are $1/16$ " to $1/8$ " from the outside of the drive belt.
4. Tighten nut.
5. Test the belts ability to stop. If the belt continues to run, repeat the process.

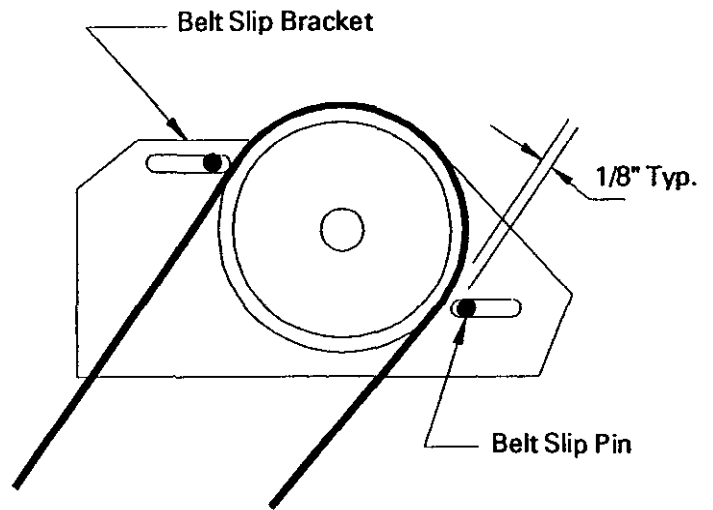
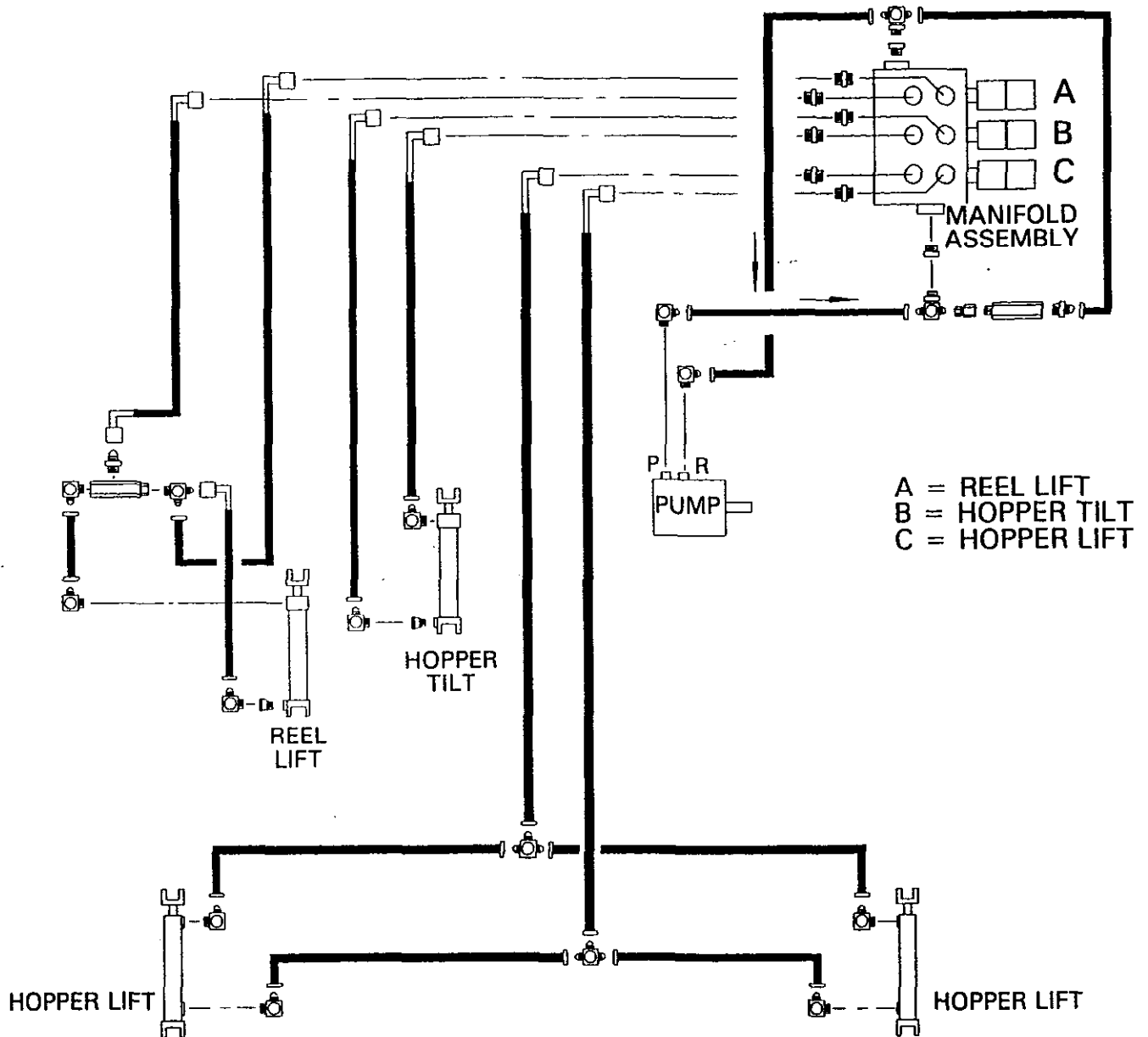
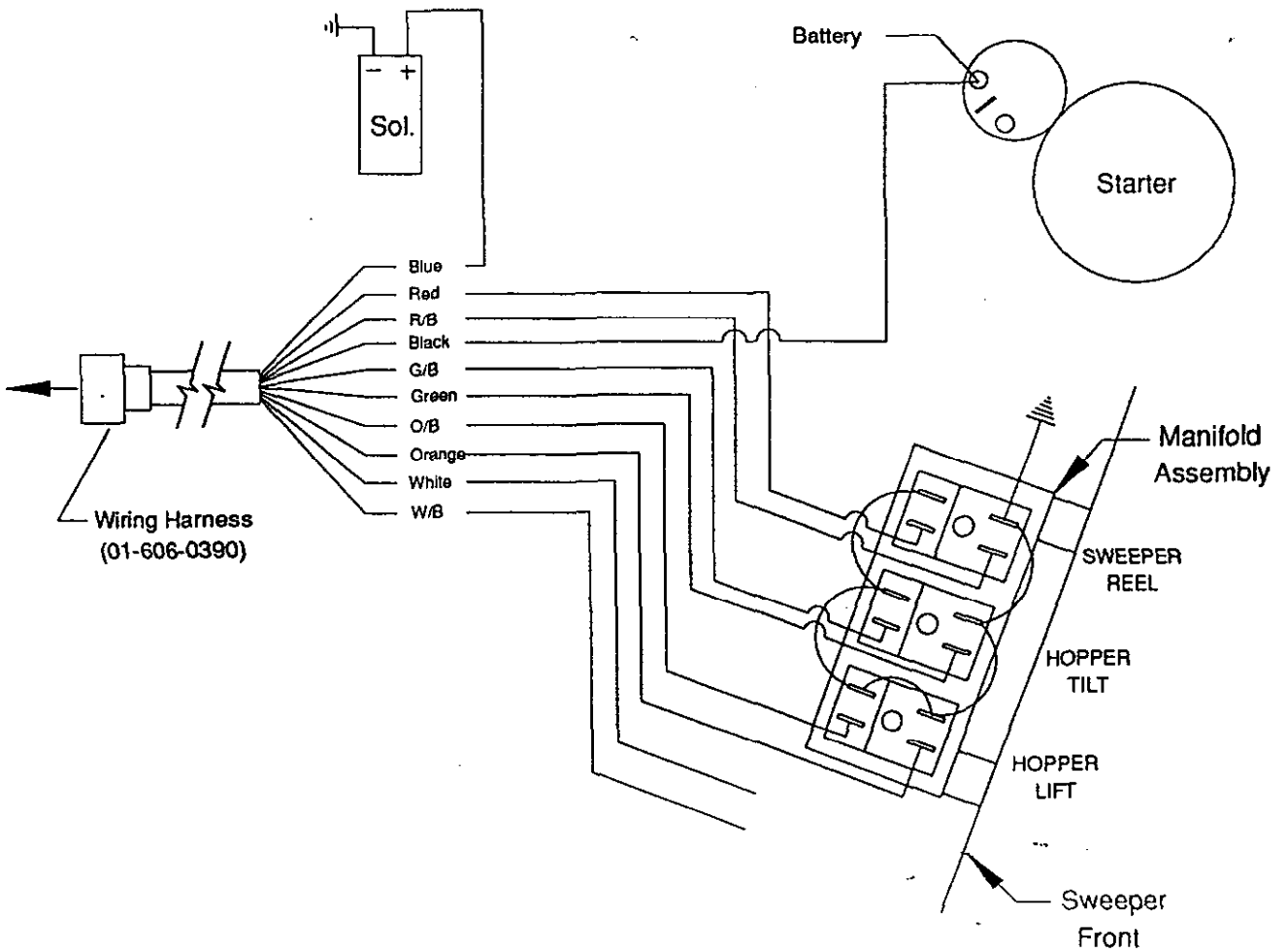
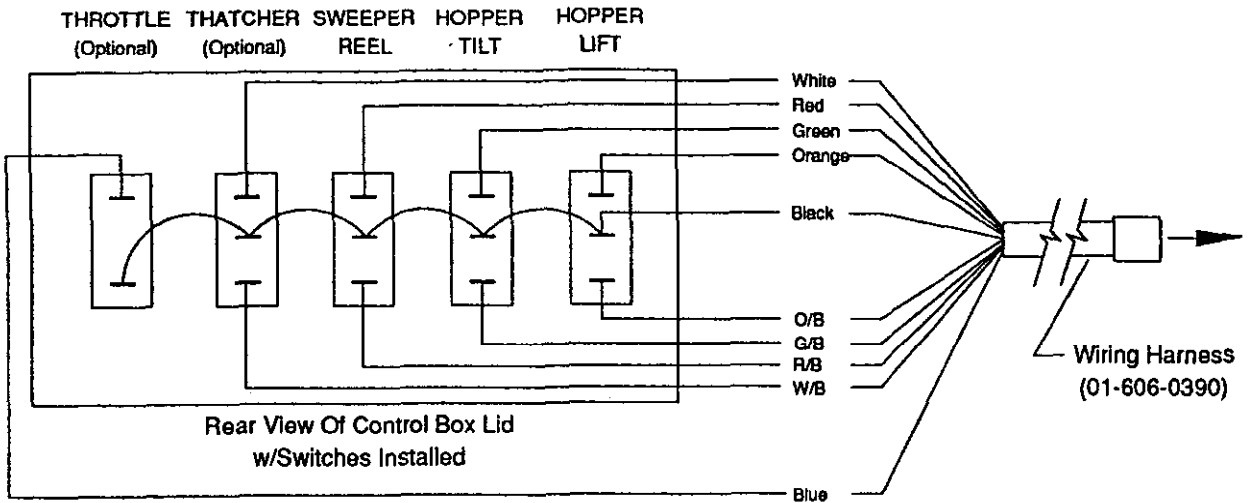

Figure 8

HYDRAULIC SCHEMATIC - 1655HL



WIRING DIAGRAM - 1655HL



TROUBLE SHOOTING

CONDITION	CAUSE	CORRECTION
<p>SWEEPER NOT PICKING UP</p>	<ul style="list-style-type: none"> • Check for missing fingers. • The reels may not be timed properly. • Broken chain. • Sheared sprocket key. • Broken belt or improper tension. • Check sheaves for sheared key. • Finger height may be too low or too high. 	<ul style="list-style-type: none"> • Replace missing or broken fingers. • See SWEEPER REELS TIMING CHAIN ADJUSTMENTS • Replace chain or sprocket key. • Replace sprocket key. • Replace belt, adjust tension. • Replace key. • Adjust height. See SWEEPER REELS LEVELING AND HEIGHT ADJ. in manual.
<p>EXCESSIVE VIBRATION</p>	<ul style="list-style-type: none"> • Check bearings on reel shaft. If they are excessively hot, they probably are damaged. • Foreign materials wrapped around reel shaft. • Reels could be bent. Should be within .015 for straightness. 	<ul style="list-style-type: none"> • Replace any damaged bearings. • Clean off any foreign objects. • Check shaft with dial calipers.

STORAGE

1. Thoroughly clean the sweeper so it is free of dirt, leaves and debris.
2. Inflate tires to 22 PSI.
3. Check all fasteners. Tighten as necessary.
4. Grease or oil all grease fittings and bearings. Wipe off excess lubricant.
5. Drain and replace hydraulic fluid. Inspect all hydraulic lines and fittings. Replace if necessary. Refer to the Maintenance section.
6. Check the tension and condition of the drive chain. Adjust the tension if necessary and lightly coat the chain with grease.
7. Check the tension and condition of the drive belt.
8. Check the condition of the rubber fingers. Replace any broken or missing fingers.
9. Store the Control Box and wiring inside the Belt Guard.
10. Service the battery and cables as follows:
 - A. Remove the battery terminals from the battery posts.
 - B. Clean the battery, terminals and posts with a wire brush and baking soda solution.

C. Coat the cable terminals and battery posts with Grafo 112X skin over grease (Toro Part Number 505-46), or petroleum jelly to prevent corrosion.

D. Slowly recharge the battery every 60 days for 24 hours to prevent lead sulfating of the battery.

ENGINE

1. Drain the engine oil from the oil pan and replace drain plug.
2. Remove and discard the oil filter. Install a new oil filter.
3. Refill oil pan with 2-1/2 quarts of SF - CC, 10W30 motor oil.
4. Start the engine and run at idle speed for approximately two minutes.
5. Stop the engine.
6. Thoroughly drain all fuel from the fuel tank, lines and the fuel pump filter.
7. Flush the fuel tank with fresh clean gasoline.
8. Re-secure all fuel system fittings.

IDENTIFICATION AND ORDERING

MODEL AND SERIAL NUMBER

The TURF SWEEPER 1655HL has two identification numbers: a model and serial number. The two numbers are stamped on a plate which is riveted to the main frame. In any correspondence concerning the TURF SWEEPER 1655HL, supply model and serial numbers to be sure that the correct information and replacement parts are obtained.

To order replacement parts from an authorized TORO Distributor, supply the following information.

1. Model and serial numbers of the machine.
2. Part number, description and quantity of parts desired.

Note: Do not order by reference number if a parts catalog is being used; use the part number.

The Toro Promise

A ONE YEAR LIMITED WARRANTY

The Toro Company promises to repair your TORO Product if defective in materials or workmanship. The following time periods from the date of purchase apply:

Commercial Products 1 Year

The costs of parts and labor are included, but the customer pays the transportation costs on walk rotary mowers with cutting widths of less than 25".

If you feel your TORO product is defective and wish to rely on The Toro Promise, the following procedure is recommended:

1. Contact your Authorized TORO Distributor or Commercial Dealer (the Yellow Pages of your telephone directory is a good reference source).
2. The TORO Distributor or Commercial Dealer will advise you on the arrangements that can be made to inspect and repair your product.
3. The TORO Distributor or Commercial Dealer will inspect the product and advise you whether the product is defective and, if so, make all repairs necessary to correct the defect without an extra charge to you.

If for any reason you are dissatisfied with the distributor's analysis of the defect or the service performed, you may contact us.

Write:

TORO Commercial Products Service Department
8111 Lyndale Avenue South
Minneapolis, Minnesota 55420

The above remedy of the product defects through repair by an Authorized TORO Distributor or Commercial Dealer is the purchaser's sole remedy for any defect.

THERE IS NO OTHER EXPRESS WARRANTY. ALL IMPLIED WARRANTIES OF MERCHANTABILITY AND FITNESS FOR USE ARE LIMITED TO THE DURATION OF THE EXPRESS WARRANTY.

Some states do not allow limitations on how long an implied warranty lasts, so the above limitation may not apply to you.

This Warranty applies only to parts or components which are defective and does not cover repairs necessary due to normal wear, misuse, accidents, or lack of proper maintenance. Regular, routine maintenance of the unit to keep it in proper condition is the responsibility of the owner.

All warranty repairs reimbursable under the Toro Promise must be performed by an Authorized TORO Commercial Dealer or Distributor using Toro approved replacement parts.

Repairs or attempted repairs by anyone other than an Authorized TORO Distributor or Commercial Dealer are not reimbursable under the Toro Promise. In addition, these unauthorized repair attempts may result in additional malfunctions, the correction of which is not covered by warranty.

THE TORO COMPANY IS NOT LIABLE FOR INDIRECT, INCIDENTAL OR CONSEQUENTIAL DAMAGES IN CONNECTION WITH THE USE OF THE PRODUCT INCLUDING ANY COST OR EXPENSE OF PROVIDING SUBSTITUTE EQUIPMENT OR SERVICE DURING PERIODS OF MALFUNCTION OR NON-USE.

Some states do not allow the exclusion or limitation of incidental or consequential damages, so the above limitation or exclusion may not apply to you.

This warranty gives you specific legal rights, and you may also have other rights which vary from state to state.

COUNTRIES OTHER THAN THE UNITED STATES OR CANADA

Customers who have purchased TORO products exported from the United States or Canada should contact their TORO Distributor (Dealer) to obtain guarantee policies for your country, province or state. If for any reason

you are dissatisfied with your Distributor's service or have difficulty obtaining guarantee information, contact the TORO importer. If all other remedies fail, you may contact us at The Toro Company.