

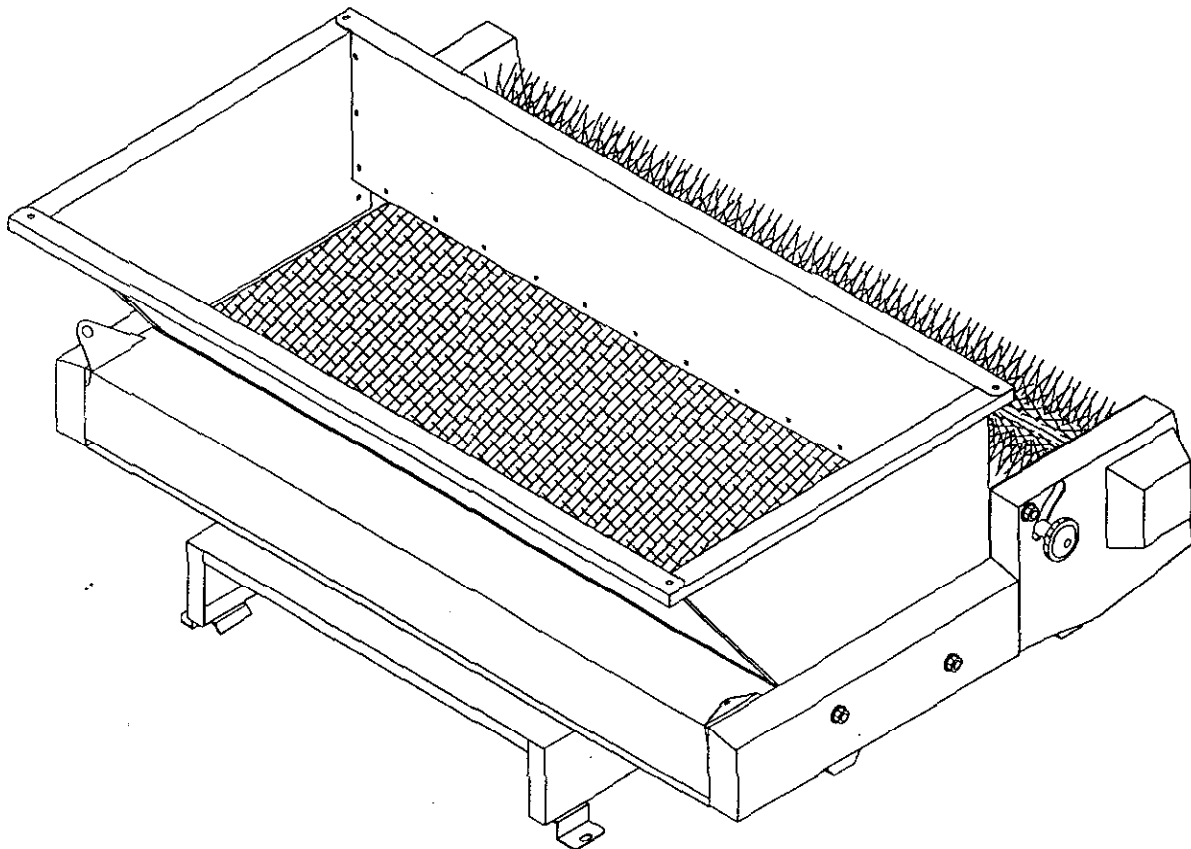

MODEL NO. 44220 - 70001 & UP

OPERATOR'S
MANUAL

TOPDRESSER 1800
WORKMAN™ 3000 ATTACHMENT



FOREWORD

Thank you for buying a high quality Toro turf care product. To get the best performance from this machine, operate and maintain it according to the instructions in this manual.

Toro also wants to stress the importance of safety. You and anyone else using or maintaining this machine are strongly urged to read this manual, especially all the safety instructions.

DANGER, **WARNING** and **CAUTION**, used with the triangular safety alert symbol, highlight safety messages. Always read and understand these messages because they relate to personal injury and your safety.

If you ever need help or have questions about your new Toro turf care product, contact your local Authorized Toro Distributor. The Toro Distributor has a complete supply of replacement parts, a full line of accessories and a professional service staff to support you. Keep your Toro all Toro. Buy genuine Toro parts and accessories.

TABLE OF CONTENTS

	Page		Page
SAFETY INSTRUCTIONS	3 - 4	Brush To Conveyor Belt Adjustment	16
SAFETY AND INSTRUCTION DECALS	5	Chain Tension	16
SPECIFICATIONS	5	Rotation	17
SET UP INSTRUCTIONS	6 - 11	Conveyor Belt Installation/Tension	17
BEFORE OPERATING	12	Conveyor Belt Lacing	17
CONTROLS	12	Conveyor Belt/Pulley Alignment	18
OPERATING INSTRUCTIONS	12 - 13	HYDRAULIC SCHEMATIC	19
LUBRICATION	14	STORAGE	20
MAINTENANCE		IDENTIFICATION AND ORDERING	20
Working On Engine Or Hydraulics	15	WARRANTY	Back Cover
Hydraulics	15		

SAFETY INSTRUCTIONS



The safety alert symbol means **CAUTION, WARNING or DANGER** - "personal safety instruction". Read and understand the instruction because it has to do with safety. Failure to comply with the instruction may result in personal injury.

BEFORE OPERATING

1. Read and understand all operating and safety instructions. Before operating this unit, become familiar with all controls and know how to stop quickly. A replacement manual is available by sending complete Model and Serial Number to:

The Toro Company
8111 Lyndale Avenue South
Minneapolis, MN, 55420

2. Read and understand all operating and safety instructions in the Operator's Manual for the Toro Workman™.

3. Before each use, be sure all bolts and nuts are tight. Always make sure Topdresser mounting pins and fasteners are in place and secure.

4. Do not modify this equipment in any manner.

5. Keep all shields, safety devices and decals in place. If a shield, safety device or decal is malfunctioning, illegible or damaged, repair or replace before operating the machine. The front 1/3 area of the Workman cargo zone must be covered by a 1/3 attachment or shield when using the topdresser.

6. This vehicle is designed to carry Only You, the operator, and One Passenger in the seat provided by the manufacturer. **NEVER** carry passengers on the machine, and keep everyone away from the areas of operation.

7. **NEVER** allow children to operate the machine. Do not allow adults to operate the machine without proper instructions. Only trained and authorized persons should operate this vehicle. Anyone who operates the vehicle should have a motor vehicle license.

8. Make sure all hydraulic fittings are tight and all hydraulic hoses are in good condition before operating this unit.

WHILE OPERATING

9. Keep hands and feet out of hopper when unit is operating or engine is running on vehicle.

10. Operator and passenger should remain seated whenever the vehicle is in motion.

SAFETY INSTRUCTIONS (Continued)

11. Using the machine demands attention. Failure to operate vehicle safely may result in an accident, tipover of vehicle and serious injury or death. Drive carefully. To prevent tipping or loss of control:

A. Use extreme caution, reduce speed and maintain a safe distance around sand traps, ditches, creeks, ramps, any unfamiliar areas or other hazards.

B. Watch for holes or other hidden hazards.

C. Use caution when operating vehicle on a steep slope. Normally travel straight up and down slopes. Reduce speed when making sharp turns or when turning on hillsides. Avoid turning on hillsides whenever possible.

D. Use extra caution when operating vehicle on wet surfaces, at higher speeds or with a full load. Stopping time will increase with a full load. Shift into a lower gear before starting up or down a hill.

E. Avoid sudden stops and starts. Do not go from reverse to forward or forward to reverse without coming to a complete stop.

F. Do not attempt sharp turns or abrupt maneuvers or other unsafe driving actions that may cause a loss of vehicle control.

G. Before backing up, look to the rear and assure no one is behind. Back up slowly.

H. Watch out for traffic when near or crossing roads. Always yield the right of way to pedestrians and other vehicles. This vehicle is not designed for use on streets or highways. Always signal your turns or stop early enough so other persons know what you plan to do. Obey all traffic rules and regulations.

I. Always watch out for and avoid low overhangs such as tree limbs, door jambs, overhead walkways, etc. Make sure there is enough room over head to easily clear the vehicle and your head.

J. If ever unsure about safe operation, STOP WORK and ask your supervisor.

12. When loading with sand, distribute load evenly. Operate vehicle with extra caution when the hopper is full of sand. Keep load balanced to prevent it from shifting.

MAINTENANCE

13. Before servicing or making adjustments to the topdresser, stop engine of Workman, set parking brake and remove key from engine to prevent accidental starting of the engine.

14. Make sure all hydraulic line connectors are tight and all hydraulic hoses and lines are in good condition before applying pressure to the system.

15. Keep body and hands away from pin hole leaks or nozzles that eject hydraulic fluid under pressure. Use paper or cardboard, not hands to search for leaks. Hydraulic fluid escaping under pressure can have sufficient force to penetrate skin and do serious damage. If fluid is injected into skin it must be surgically removed within a few hours by a doctor familiar with this form of injury or gangrene may result.

16. To make sure entire machine is in good condition, keep all nuts, bolts and screws properly tightened.

17. To reduce potential fire hazard, keep the engine of the Workman free of excessive grease, grass, leaves and accumulation of dirt.

18. If the engine must be running to perform a maintenance adjustment, keep hands, feet, clothing, and any parts of the body away from the engine and any moving parts. Keep everyone away.

19. If major repairs are ever needed or assistance is required, contact an Authorized TORO Distributor.

20. To be sure of optimum performance and safety, always purchase genuine TORO replacement parts and accessories. Replacement parts and accessories made by other manufactures could be dangerous. Altering this vehicle in any manner may affect the vehicle's operation, performance, durability or its use may result in injury or death. Such use could void the product warranty of The Toro Company.

SAFETY AND INSTRUCTION DECALS

The following safety and instruction decals are installed on the unit. Replace any decals that becomes damaged or illegible. Part numbers for decals are listed below and in your Parts Catalog. Order replacements from your Authorized Toro Distributor.

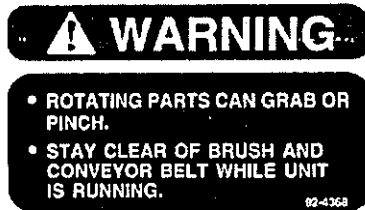

BOTH SIDES HOPPER BACK
(Part No. 92-4368)

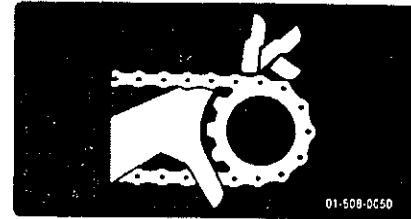

CHAIN GUARD
(Part No. 01-506-0050)

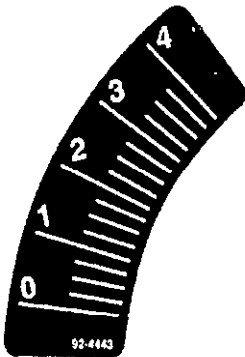

LINED UP WITH GATE CONTROL
(Part No. 92-4443)

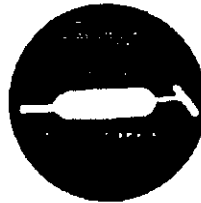

ON GUARDS NEAR BEARINGS
(Part No. 58-6520)

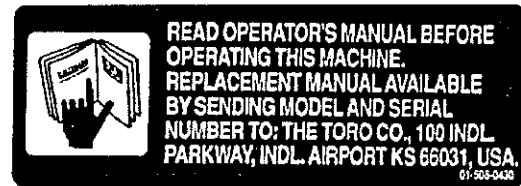

ON BASE MOUNTING
(Part No. 01-506-0430)

SPECIFICATIONS

Dimensions:

Height: 28" (71cm)
Length: 50" (127cm)
Width: 68" (173cm)

Hopper Dimensions:

Height: 16" (41cm)
Top Length: 31" (79cm)
Bottom Length: 20" (51cm)
Width: 60" (152cm)

Hopper Capacity: 18 cubic feet (.5m³)

Spreading Width: 60"

Top Dressing Speed: Varies depending on desired application rate.

Conveyor Belt: Continuous 60" wide composition belt with heavy duty polyester cord.

Metering Gate: Infinitely variable from closed to 3" (7.6cm) opening for light to heavy applications.

Drive: Hydraulic driven with Workman remote hydraulics.

Shipping Weight: 700 lbs.

Dry Weight: 650 lbs.

SET UP INSTRUCTIONS

NOTE: The Remote Hydraulic Control Kit (Model 07415) must be installed on the Workman before installation of the Topdresser 1800.

NOTE: It is recommended that an engine cover kit (92-1344 or 92-5963) be installed to prevent material overflow directly onto the engine.

ATTACHING TOPDRESSER BASE TO WORKMAN (Fig. 1 & 1A)

1. Attach both Bracket Attachment Mounts (92-2667) to both sides of the Workman as shown in Fig. 1. Attach with bolts and nuts already in the frame but do not tighten.

NOTE: If Workman has a H.D. Hitch Frame installed, the Bracket Attachment Mounts will already be attached. Two Spacer - Mounts (92-4576) must be installed to mount the Base to the Workman. See Fig. 1A.

2. Set the Mounting Base (92-4351) of the topdresser on the Workman as shown in Fig. 1 or 1A.

3. Attach both clevis pins (92-1233) to the rear of the frame and secure with lynch pins (92-1298).

4. Connect the Mounting Base to the Bracket Attachment Mounts using the bolts and nuts. Secure all six bolts.

5. Attach the Rubber Cover to the front of the base using the Clamp-Rubber as shown in Fig. 1. Secure using the 1/4" x 1" bolts.

6. Place the Remote Hydraulic Valve Handle of the Workman in the float position.

The Workman's hydraulic system operates on Dexron II automatic transmission fluid. This fluid provides gear and bearing lubrication as well as fluid for operating the hydraulic system.

When the remote hydraulic system quick couplers are connected, hydraulic fluid flows from the topdresser to the vehicle. If the hydraulic fluid in the topdresser is not the same or equivalent to vehicle's, component damage to transaxle or hydraulic system may result.

Fluid compatibility should be checked and appropriate action taken, if topdresser is subsequently used in conjunction with any other product using fluids other than Dexron II ATF.

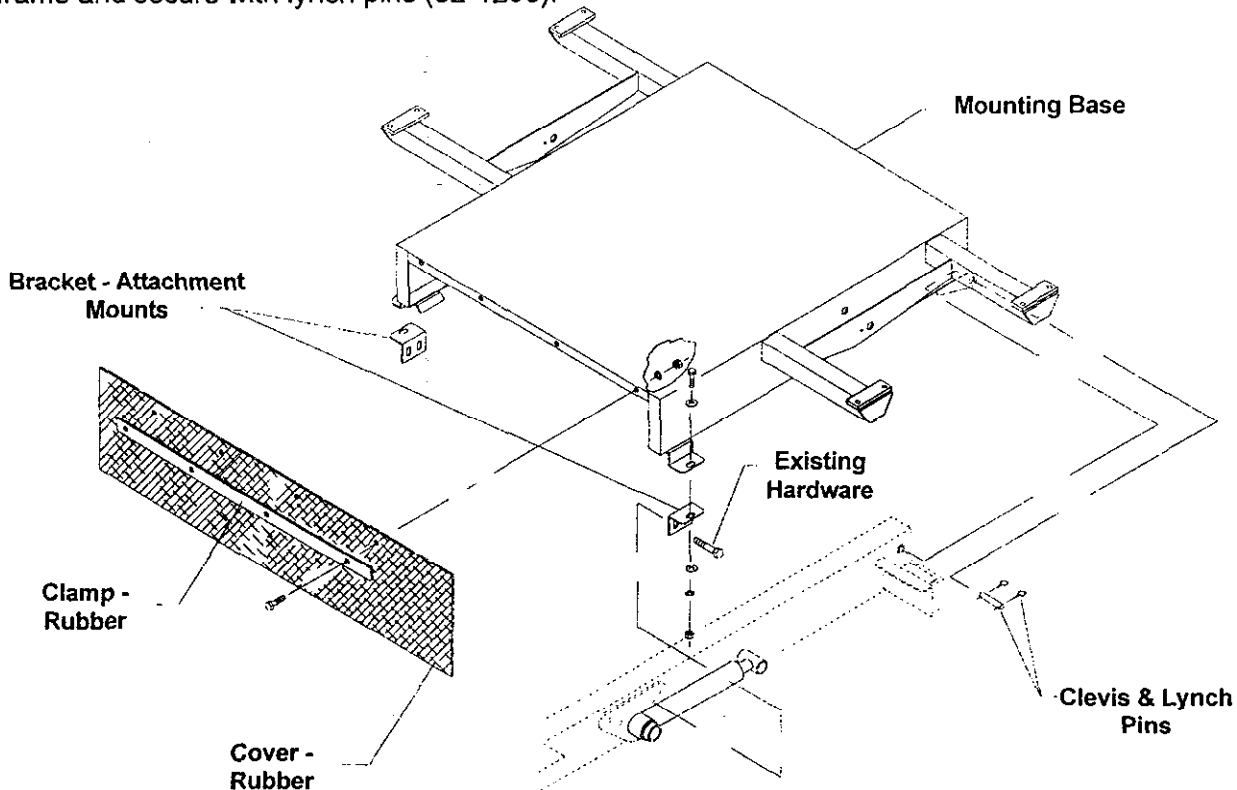

Figure 1

SET UP INSTRUCTIONS (Continued)

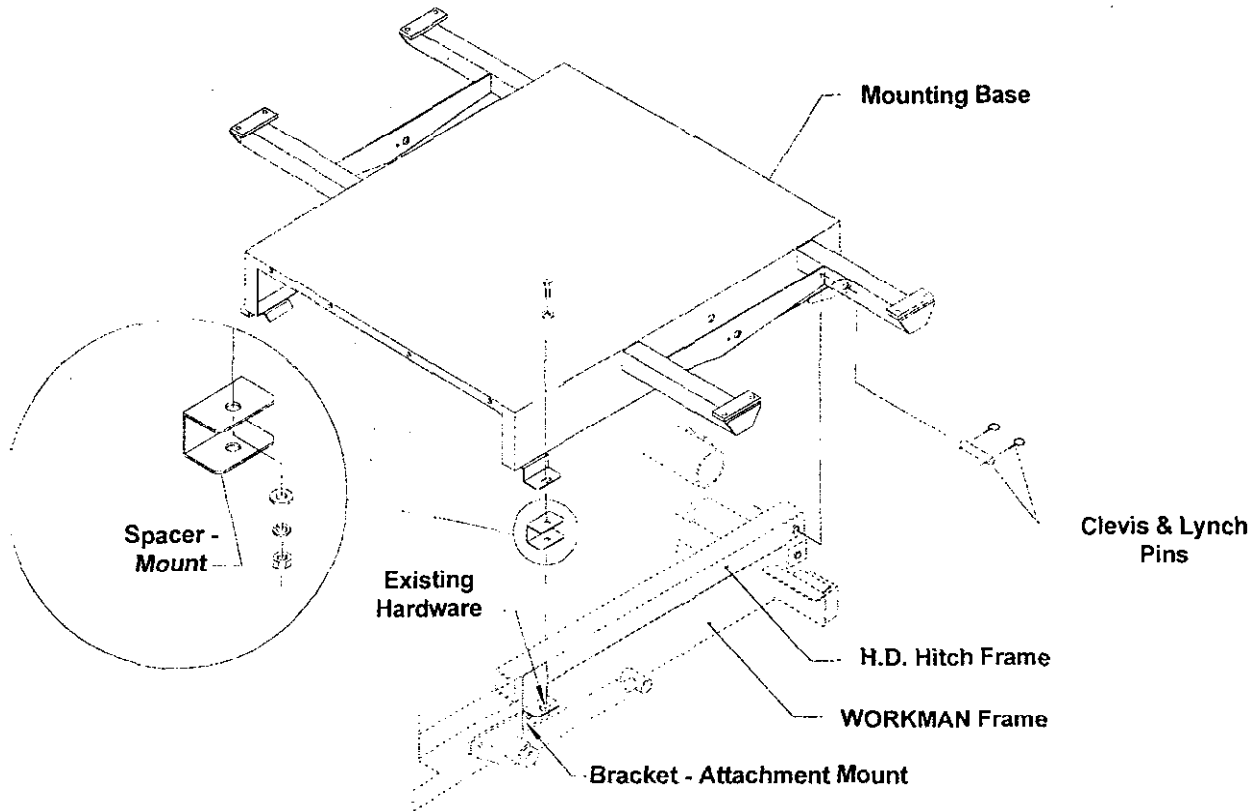

Figure 1A

ATTACHING TOPDRESSER BASE TO WORKMAN (Continued)

7. Clean dirt from quick couplers before connecting. Dirty couplers can introduce contamination to the system. After cleaning, attach both quick couplers on the topdresser to the Workman. The hoses are marked "A" and "B", match them to the quick couplers when installing.

IMPORTANT: Check hydraulic oil level after installation of Topdresser 1800. Check operation of topdresser, then recheck hydraulic oil level. Operation of vehicle with low oil level can damage pump, remote hydraulics, power steering and vehicle transaxle. Use Dexron II automatic transmission fluid if needed.

8. Start vehicle engine and test rotation of the conveyor and brush. Place remote hydraulics lever of Workman in the "run" position. The rotation should be as shown in Fig. 11. If the rotation is backwards the quick couplers need to be reversed.

CAUTION

Hydraulic fluid escaping under pressure can have sufficient force to penetrate skin and do serious damage. Care must be used when connecting or disconnecting hydraulic couplers. Stop engine, apply parking brake and place remote hydraulic valve in float detent position to relieve hydraulic pressure before connecting or disconnecting quick couplers.

9. Move the locking tab of the lift cylinders into "Lock" position to prevent cylinders from accidentally extending.

SET UP INSTRUCTIONS (Continued)

TROUBLESHOOTING

A. Difficulty in connecting or disconnecting quick couplers:

Pressure not relieved (Quick coupler under pressure).

Engine running.

Remote hydraulic valve not placed in float.

B. Power Steering Hard:

Remote hydraulic valve linkage out of adjustment.

Hydraulic oil level low.

Hydraulic oil hot.

C. Hydraulic leaks:

Fittings loose.

Fitting missing o-ring.

D. Attachment does not function:

Quick couplers not fully engaged.

Quick couplers are interchanged.

SET UP INSTRUCTIONS (Continued)

ASSEMBLE HOPPER (Fig. 2 & 3)

NOTE: Do not secure bolts until all of the hopper is assembled.

1. Remove all four Guards from each side of the unit. (Part numbers 92-4356, 92-4360, 92-4357 and 92-4361.)

2. Attach the Hopper Brace (F) to Base Frame using (4) 1/4" x 5/8" carriage bolts and whiz nuts.

3. Attach the rear (D) to the Hopper Brace using 1/4" x 5/8" carriage bolts and whiz nuts. Assemble the sides (C), side Rubber Skirts (H) and Hopper Corner Strips (E) to the Rear (D). Do not secure hardware.

4. Attach both L.H. and R.H. Support Rods (K & L) through the hopper as shown in Fig. 2.

5. Attach the Front Rubber Skirt (G) to the Front (A) with Hopper Strips (B) to the sides and bottom of topdresser using 1/4" x 5/8" carriage bolts and whiz nuts. Secure hardware.

IMPORTANT: The rubber (G and H) must be mounted so it is on top of the conveyor belt between it and the hopper bottom. The Side Rubber "H" should be on top of "G". This prevents leakage of sand.

The rubber flaps must be installed on the topdresser. If the flaps are not installed, damage will occur to the conveyor belt and rollers.

NOTE: Hopper Corner Strips are to be installed on the inside of the hopper.

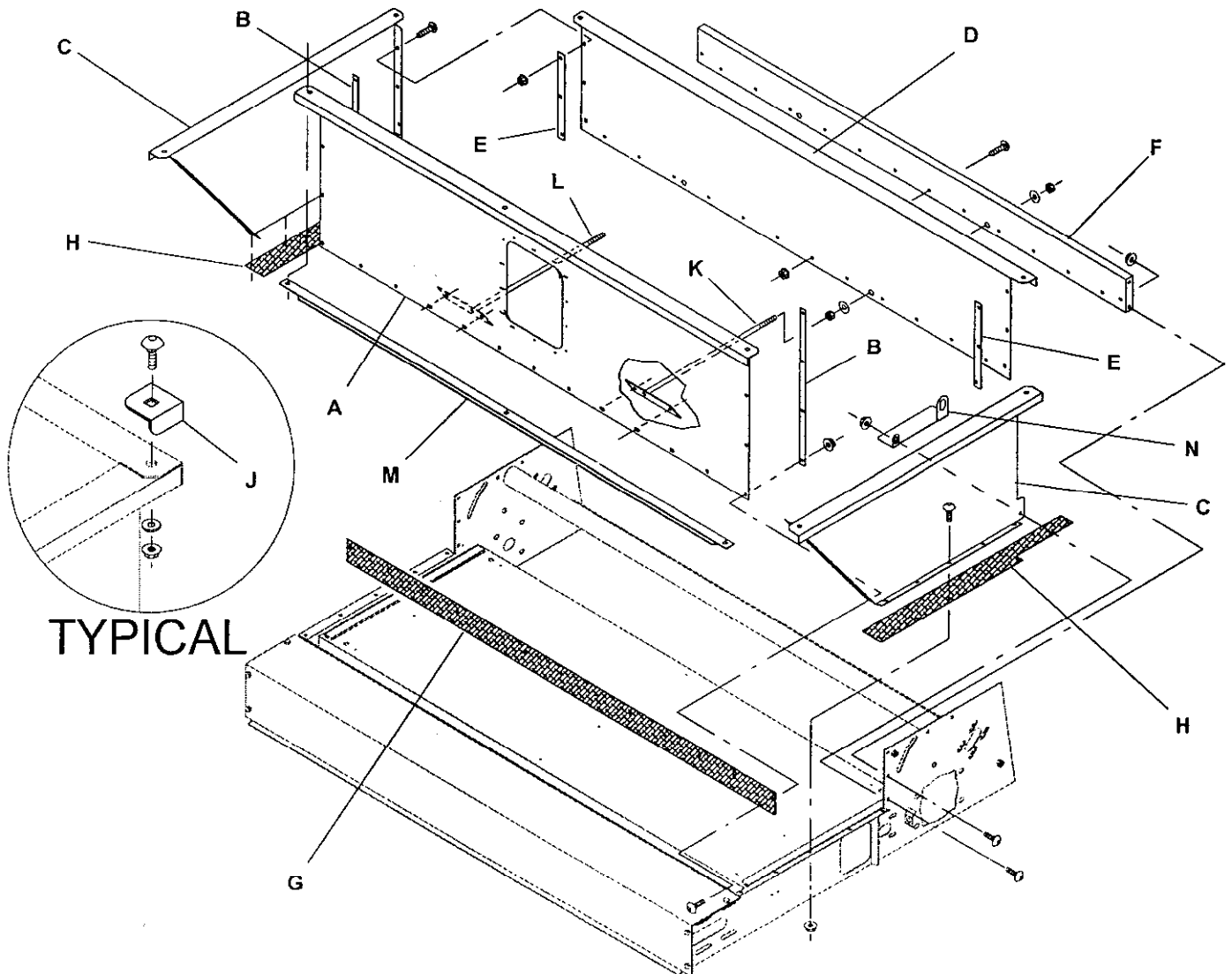

Figure 2

SET UP INSTRUCTIONS (Continued)

ASSEMBLE HOPPER (Continued)

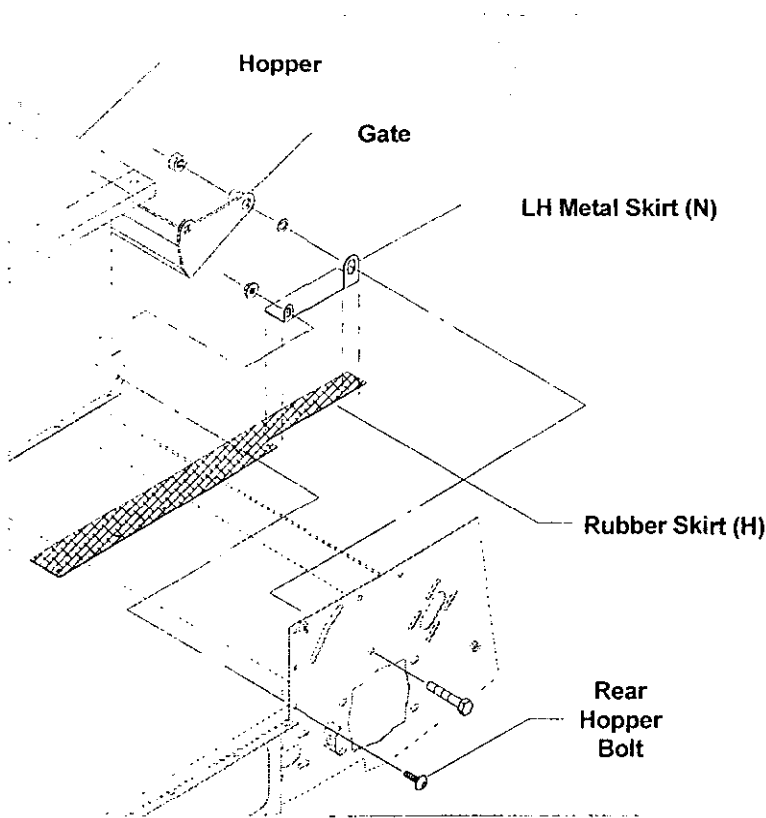

Figure 3

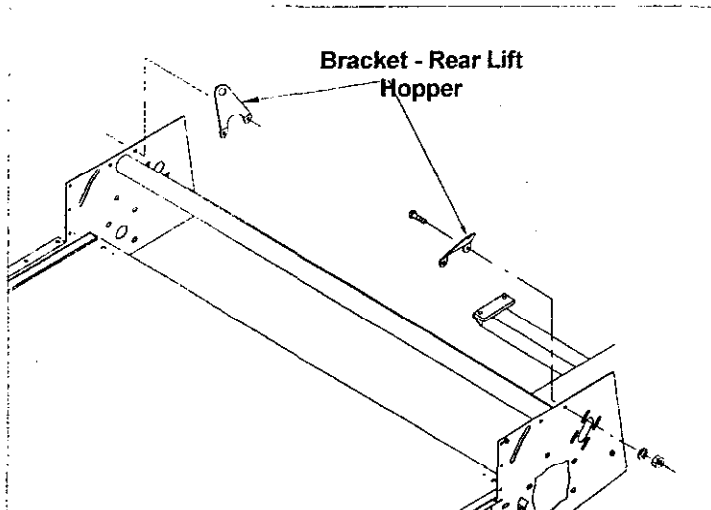

Figure 4

6. Secure the LH and RH metal skirts (N) to the hopper and side frame with 1/4" x 5/8" carriage bolts. Secure tightly.

NOTE: Only the LH metal skirt is shown in Fig. 2 and Fig. 3.

7. Attach the Hopper Brace (M) under the front channel of the Hopper Front as shown in Fig. 2. Secure center holes with 1/4" x 5/8" carriage bolts.

8. Attach (4) Corner Brackets (J) to the corners of the hopper including the front Hopper Brace .

9. Secure all bolts for hopper tightly.

NOTE: Adjust Support Rods (L) to clear gate.

10. Attach the Bracket-Rear Lift to each side of the Topdresser as shown in Fig. 4. Use 3/8" x 1" bolts and secure tightly.

SET UP INSTRUCTIONS (Continued)

INSTALL OPTIONAL LIFT ASSEMBLY (Fig. 5)

The Lift Assembly Kit (92-4452) is used to remove or install the Topdresser 1800 from the Workman.

1. Place the Bracket Lift Weldment (92-4448) on top of the hopper.
2. Attach the chains as shown in Fig. 5.

IMPORTANT: When removing the topdresser, using the Lift Assembly, **ALWAYS** remove the front attaching bolts and pins before lifting.



WARNING

WHILE USING THE OPTIONAL LIFT ASSEMBLY:

DO NOT position yourself under the topdresser while removing or installing.

DO NOT allow anyone else near the topdresser while removing or installing.

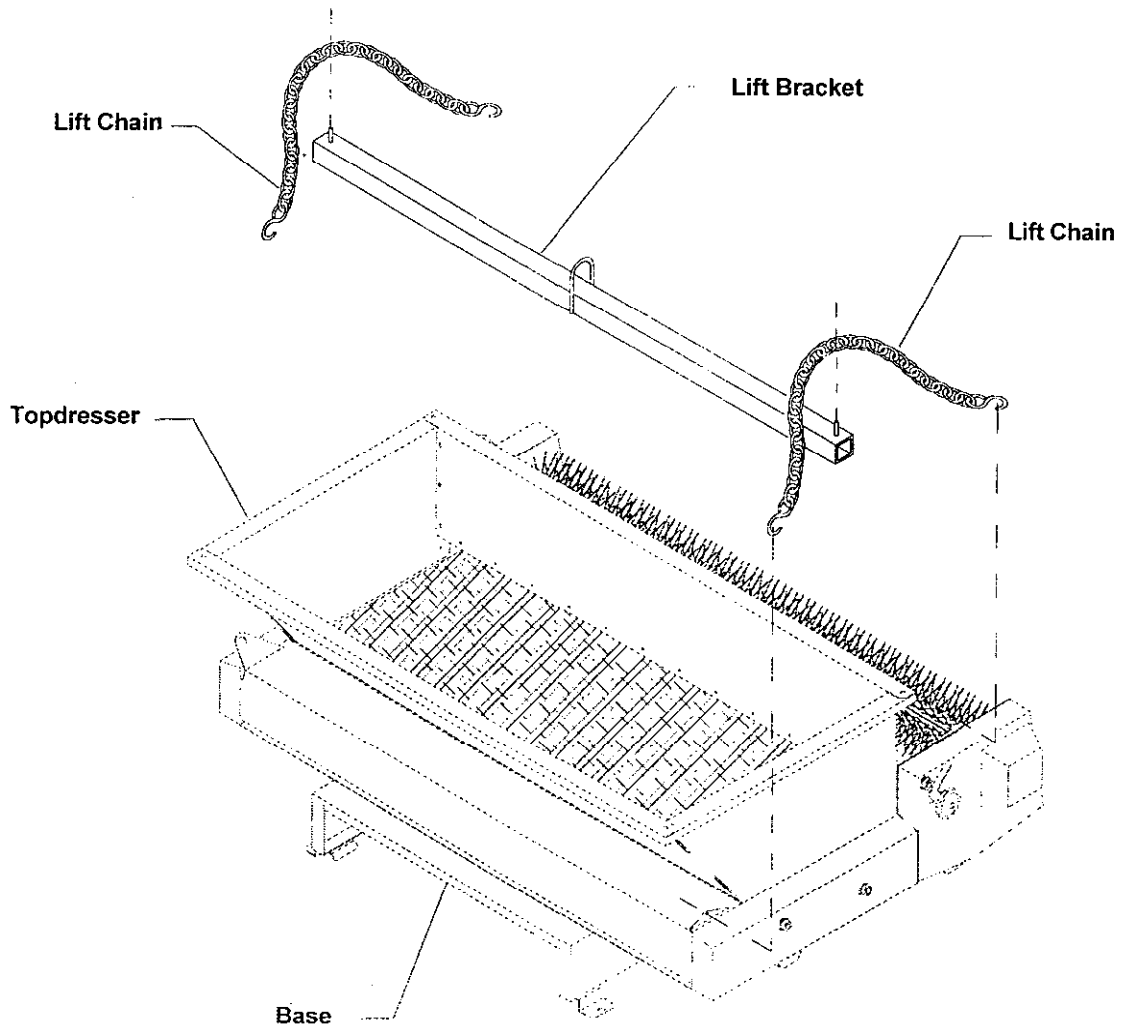

Figure 5

BEFORE OPERATING

CHECK HYDRAULIC SYSTEM

1. Visually inspect the hydraulic system for leaks, loose fasteners, missing parts, improperly routed lines. Make all repairs before operating.
2. Assure both quick couplers are full engaged.

CONTROLS

GATE CONTROL (Fig. 6)

The black knob on the left side of the unit, near the brush, is used to lock the gate into the desired open height position.

1. Loosen the black knob enough to allow it to pivot freely in the slot.
2. Set the gate into the desired position and tighten the black knob to lock into position.

NOTE: CE equipped units require the opening of the access flap on the brush guard before positioning the gate.

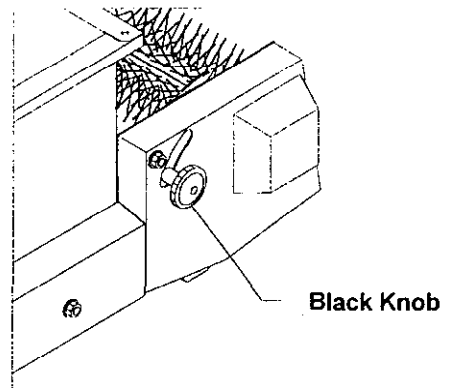

Figure 6

OPERATING INSTRUCTIONS



WARNING

Rotating parts can grab or pinch. Stay clear of brush and conveyor belt while unit is running.

Safe operation begins before taking the vehicle out for a day's work. Read and understand the operating instructions in the Toro Workman operator's manual before using the topdresser.



CAUTION

The interlock switches are for the operator's protection, so do not bypass them. Check operation of the switches daily to assure interlock system is operating on the Workman. If a switch is malfunctioning replace it before operating. Regardless whether switches are operating properly or not, replace them every two years to assure maximum safety. Do not rely entirely on safety switches - use common sense!

1. Sit on operator's seat and engage parking brake.
2. Disengage PTO (if so equipped) and return hand throttle lever to OFF position (if so equipped).
3. Move shift lever to NEUTRAL position and depress clutch lever.
4. Insert key into ignition switch and rotate it clockwise to start the engine. Release key when engine starts.
5. Practice starting, driving and stopping the Workman. Always read and understand the operator's manual for the Workman before using this unit.
6. Place sand or other topdressing material in the hopper. The maximum volume of material that can be put into the hopper is 18 cubic feet. Generally, sand weighs 100 pounds per cubic foot and could overload the Workman if more than 1400-1500 pounds are loaded into the hopper.

OPERATING INSTRUCTIONS (Continued)

IMPORTANT NOTE: When any other attachments, such as the HD Hitch frame, are installed on the Workman while using the 1800 Topdresser, the weight of those attachments must be subtracted from the payload capacity of the hopper.

A method for determining the total weight of your attachments would be to place the rear tires on a scale. **The maximum weight capacity of the rear axle of the Workman is 2600 pounds.**

7. Transport to the area to be topdressed.
8. Open the gate arm to the desired rate. Lock into position with the black knob.
9. Move the shift lever into "LO" range position. Select the desired forward speed and begin moving.
10. Pull the Remote Hydraulic Lever back to the "RUN" position. The unit is now topdressing.



IMPORTANT

As a general rule, position the weight of the load evenly from front to rear and evenly from side to side.

Transporting or topdressing with a full load can cause shifting of the sand. This shifting happens most often while turning, going up or down hills, suddenly changing speeds or while driving over rough surfaces. Shifting loads can lead to tipovers. Use caution when transporting or topdressing with a full load.

Heavy loads increase stopping distance and reduce your ability to turn quickly without tipping over.

NEVER tilt the Topdresser Bed for maintenance with any material in the hopper. Always tilt the topdresser bed with a empty hopper.

SAND APPLICATION RATE

The rate of sand being applied depends on the weight of the sand. Sand varies in moisture and coarseness which effects the weight. These factors must be taken into consideration when deciding the amount of sand required for the application. Test a small area to decide the correct amount.



WARNING

Tipping or rolling the vehicle on a hill will cause serious injury.

If engine stalls or you lose headway on a hill, never attempt to turn vehicle around.

Always back straight down a hill in reverse gear.

NEVER back down in neutral or with the clutch depressed, using only the brakes.

NEVER add sideboards or panels to the top of the hopper to increase the load capacity. The additional weight will cause tipping or rolling of the vehicle and lead to serious injury.

NEVER drive across a steep hill, always drive straight up or down. Avoid turning on a hill. Don't "drop the clutch" or slam on the brakes. Sudden speed change can initiate tipover.

LUBRICATION

BEARINGS (Fig. 7)

The topdresser has 5 self sealing bearings that must be lubricated with a No. 2 Lithium based grease.

IMPORTANT: Lubricate the bearings to maintain a slight leakage on the seals. Too much grease can cause overheating.

DRIVE CHAIN (Fig. 7)

Always maintain a light coat of grease on the drive chain.

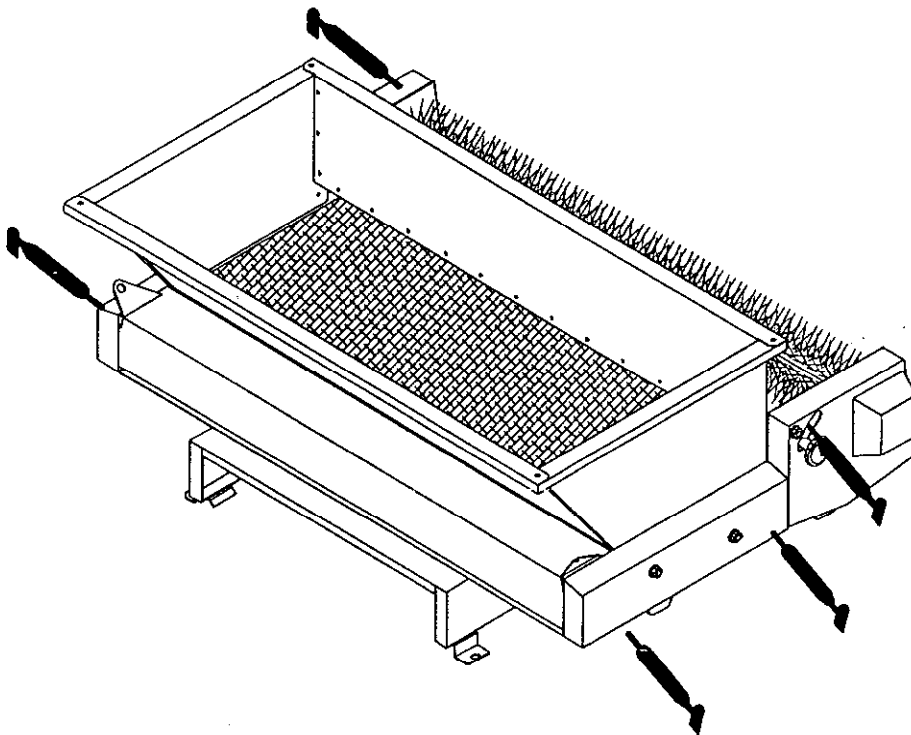

Figure 7

MAINTENANCE

WORKMAN ENGINE OR HYDRAULICS (Fig. 8)

IMPORTANT: Always unlock the Dump Stop lever before attempting to attach the cylinder for tilting.

1. The cylinders can be connected to the side of the topdresser to allow tilting of the topdresser for servicing the engine of the Workman.
2. Attach the cylinders as shown in Fig. 8. Use the tilt of the cylinders only for service of the engine or hydraulics underneath.

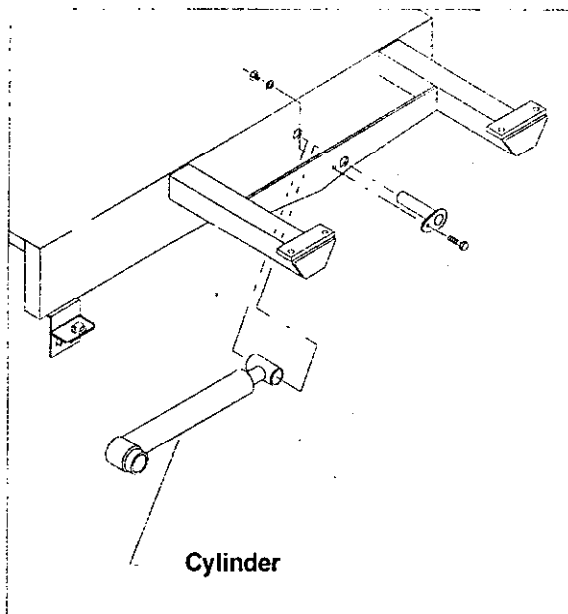

Figure 8

IMPORTANT: DO NOT rely on the cylinders to hold up the topdresser. ALWAYS block the topdresser up before going underneath to perform any type of service.

HYDRAULICS

IMPORTANT: When working with hydraulics, you must keep the work area as clean as possible. Change oil and filter as recommended. If you have a new piece of equipment under warranty and a hydraulic item goes out don't try to fix it. Install a new part and return the defective part to the factory. It is easier to get warranty on a part that has not been taken apart.

IMPORTANT: When adding oil to the system, pour it through a funnel with a fine mesh screen (200 mesh or better). Keep the funnel and containers immaculately clean. This procedure prevents accidental contamination of the hydraulic system.



CAUTION

When tilting the hopper of the topdresser back to perform maintenance on the Workman

ALWAYS remove the front mounting bolts first.

ALWAYS tilt the Topdresser with an empty load.

SAFETY SUPPORT

ALWAYS use the safety support supplied with the Workman to keep the cylinders in the extended position while performing maintenance.

MAINTENANCE

BRUSH TO CONVEYOR BELT ADJUSTMENT (Fig. 9)

The brush is moved back and forth on its mounting slots to adjust it to the conveyor belt. The brush should be as close to the belt as possible without touching. A piece of paper can be inserted between the conveyor belt and the brush to check the adjustment. The brush must be the same height from end to end. The brush adjustment should be checked weekly for wear. The bristles of the brush will wear under normal conditions and the distance from the brush to conveyor should be maintained to prevent uneven wear of the brush.

1. Loosen the nuts of the bearing housing on the right-hand side.
2. Loosen the nuts mounting the brush motor to the main frame.

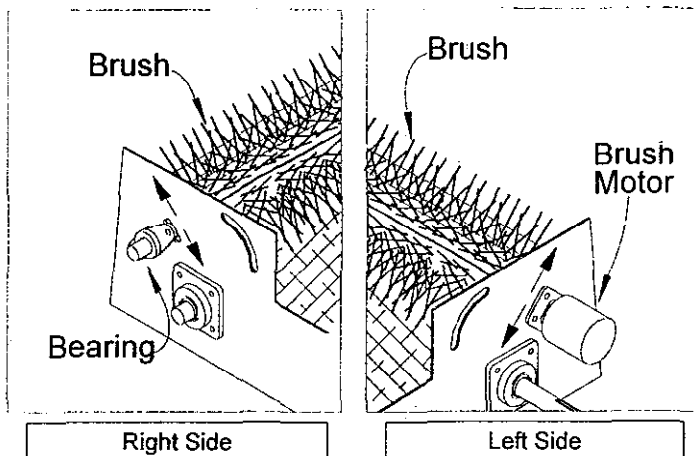

Figure 9

3. Slide the brush into position on the right hand side. Finger tighten the nuts.
4. Slide the brush into position on the left-hand side. Finger tighten the nuts.
5. Insert a piece of paper between the brush and the conveyor belt. The brush must be the same height from end to end.
6. If the adjustment is correct, tighten the nuts. If not, repeat steps 1 through 5.

CHAIN TENSION (Fig. 10)

The chain tension is adjusted with the Chain Adjustment Bolt (A). A 1/8" deflection is recommended. Do not over tighten, this will cause chain wear. Do not operate with a loose chain, this will cause sprocket wear.

1. Loosen the nuts mounting the motor and sprocket assembly (B) to the main frame.
2. Loosen the nut on the Chain Adjustment Bolt.
3. Slide the hydraulic motor and sprocket assembly (B) back and forth on the mounting slot until proper tension is achieved.
4. Lock the nut on the Chain Adjustment Bolt.
5. Tighten the nuts on the motor and sprocket assembly.

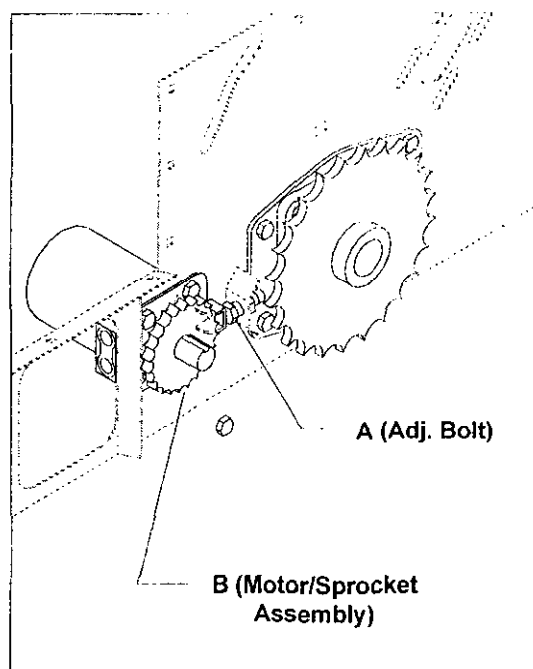

Figure 10

MAINTENANCE

ROTATION (Fig. 11)

The rotation of the conveyor, brush and the wheels is shown in Fig. 11. If the rotation is not correct, the hydraulic lines are installed incorrectly. See the Hydraulic Schematic.

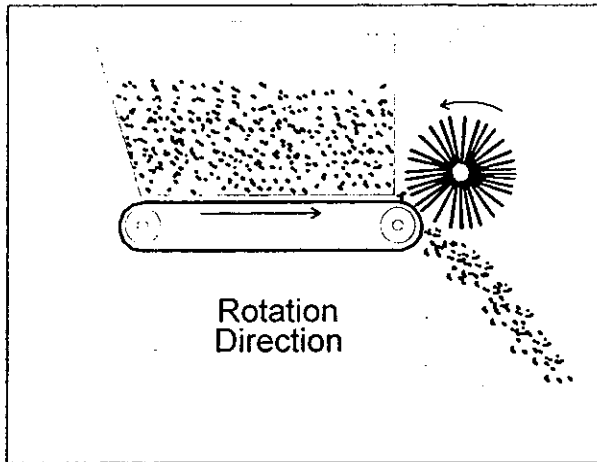

Figure 11

CONVEYOR BELT INSTALLATION/TENSION (Fig. 12 & 13)

To install a new conveyor belt follow the instructions below.

1. Turn the topdresser on until the conveyor belt seam is at the edge of the rear roller near the brush.
2. Loosen the nuts on the front bearing and release the tension on the spring by adjusting the tension adjustment nuts (A).
3. Remove the lacing (seam wire) from the old conveyor belt.

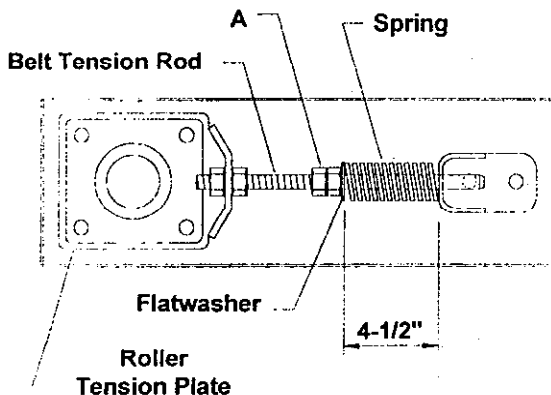

Figure 12

4. Grab one side of the old conveyor belt and pull it free from the unit.

5. Lay the new belt on the frame and roll it around the rollers bringing the seam to the edge of the rear roller.

6. Feed the lacing through the conveyor belt seam. Make sure the lacing is lined up. If the lacing is off one notch it will cause the belt to buckle and not run straight. Check for straightness with a straight edge once it has been installed. After the wire is centered, bend both ends of the wire to prevent the wire from working loose.

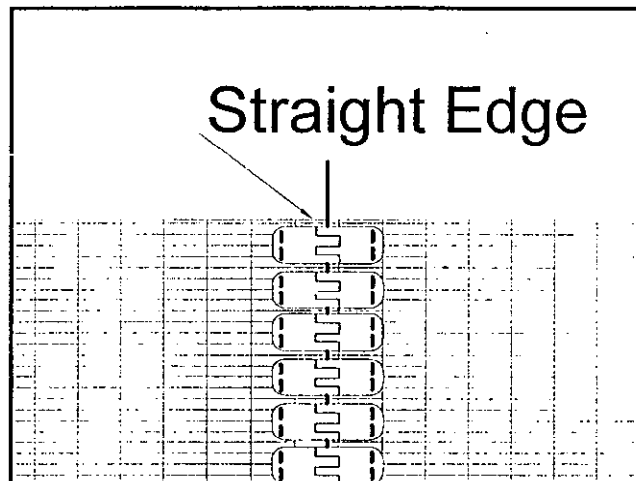

Figure 13

CONVEYOR BELT LACING/SAND LEAKAGE

The lacing on the conveyor belt has a silicone sealer on it to prevent sand leakage inside the conveyor belt. Reapply each season and everytime the lacing is removed for service. The silicone may be purchased locally. It is multipurpose, weather resistant and should be flexible or flowable.

MAINTENANCE

CONVEYOR BELT and PULLEY ALIGNMENT (Fig. 12 & Fig. 14)

1. Loosen the bearing bolts on each end of the Idler Roller. Loosen the Adjustment bolt to relieve the tension of the conveyor belt.
2. Remove the lacing pin from the conveyor belt on the Topdresser and remove the conveyor belt.
3. Loosen the set screws on all four pulleys.
4. Realign the pulleys using a long straight edge. Line the straight edge up in center of the holes on the frame (See Fig.14). The straight edge should be in the center of the V on the pulleys. Hold $58 \frac{7}{16}$ " (1484.3 mm) from center to center of the pulleys.
5. Lock the set screws on all four pulleys.
6. Replace the conveyor belt and secure with lacing.
7. Use the spring tension nuts (A) to set the tension of the belt. Hold 4-1/2" overall spring length. See Fig. 12.
8. Secure bearing bolts on the Idler Roller.

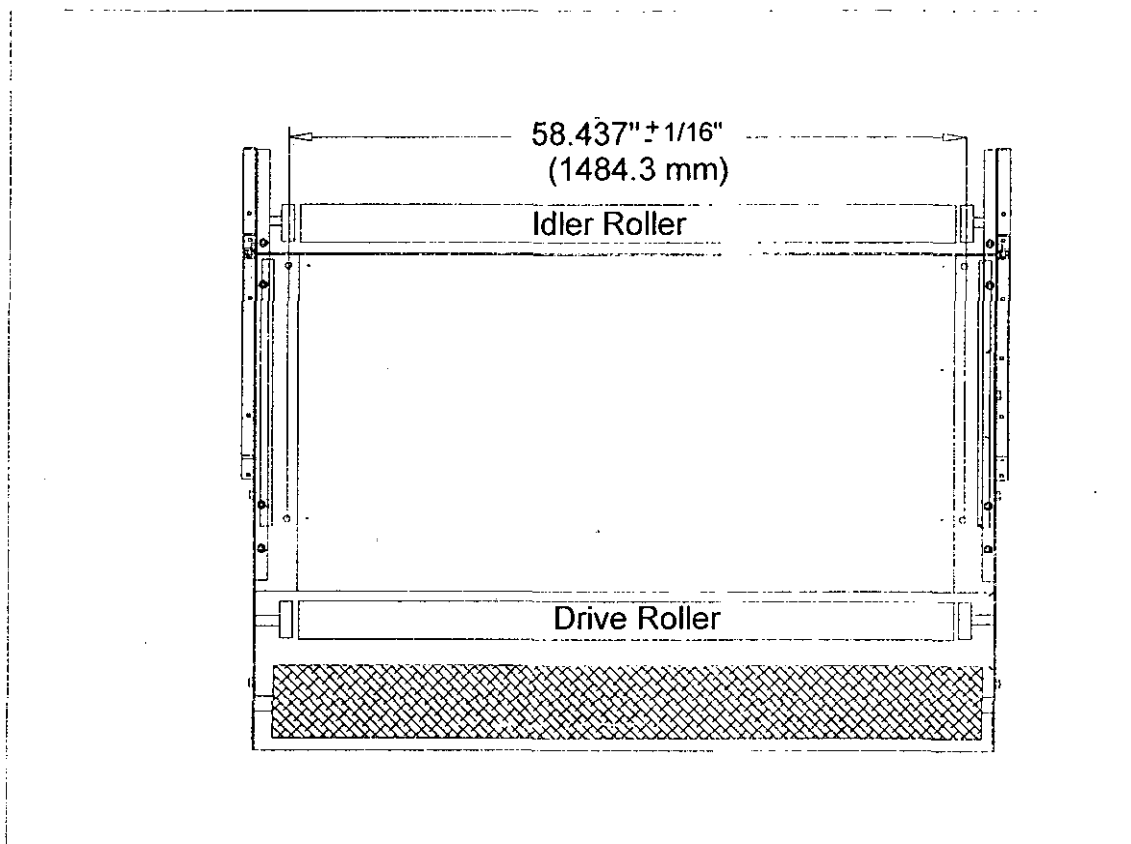
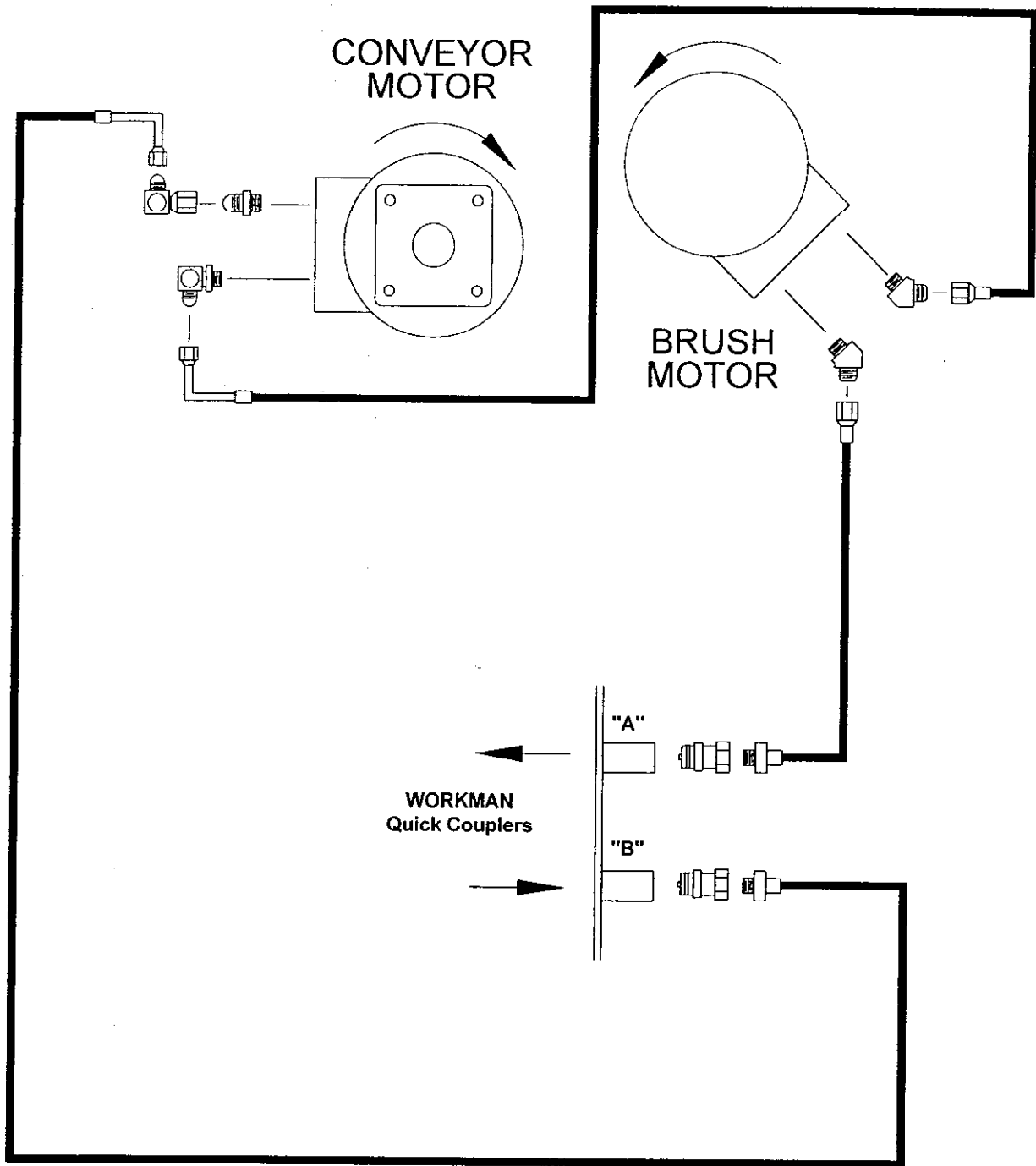

Figure 14

HYDRAULIC SCHEMATIC



SEASONAL STORAGE

1. Thoroughly clean the topdresser, especially inside the hopper. The hopper and conveyor belt area should be free of any remaining sand particles.
2. Tighten all fasteners.
3. Lubricate all grease fittings and bearings. Wipe off excess lubricant.
4. The unit should be stored out of the sun to prolong the life of the conveyor belt. When stored outside it is recommended to cover the hopper with a tarp.
5. Check the tension of the drive chain. Adjust the tension if necessary and lightly coat the chain with grease. Refer to the Maintenance section.
6. Apply a light coat of silicone to the lacing of the conveyor belt. Refer to Maintenance section.

IDENTIFICATION AND ORDERING

MODEL AND SERIAL NUMBER

The Toro Topdresser 1800 has two identification numbers: a model number and serial number. The two numbers are stamped on a plate which is riveted on the main frame. In any correspondence concerning the Topdresser 1800, supply model and serial numbers to be sure that the correct information and replacement parts are obtained.

To order replacement parts from an authorized TORO Distributor, supply the following information:

1. Model and serial numbers of the machine.
2. Part number, description and quantity of parts desired.

Note: Do not order by reference number if a parts catalog is being used; use the part number.

NOTES

NOTES

The Toro Commercial Products Two Year Limited Warranty

The Toro Company warrants your 1996 or newer Toro Commercial Product ("Product") purchased after January 1, 1997, to be free from defects in materials or workmanship for the period of time listed below*. Where a warrantable condition exists, Toro will repair the Product at no cost to you including diagnosis, labor, parts, and transportation. This warranty begins on the date the Product is delivered to the original retail purchaser.

Warranty Duration: Two years or 1500 operational hours*, whichever occurs first.

* Product equipped with hour meter.

Owner Responsibilities:

As the Product owner, you are responsible for required maintenance and adjustments stated in your Owner's Manual. Failure to perform required maintenance and adjustments can be grounds for disallowing a warranty claim.

Instructions For Obtaining Warranty Service:

You are responsible for notifying the Commercial Products Distributor or Authorized Commercial Products Dealer from whom you purchased the Product as soon as you believe a warrantable condition exists.

If you need help locating a Commercial Products Distributor or Authorized Dealer, or if you have questions regarding your warranty rights or responsibilities, you may contact us at:

Toro Commercial Products Service Department
8111 Lyndale Avenue South
Minneapolis, MN, 55420-1196
Telephone: (612) 888-8801
Facsimile: (612) 887-8258
E-Mail: Commercial.Service@Toro.Com

Maintenance Parts:

Parts scheduled for replacement as required maintenance ("Maintenance Parts"), are warranted for the period of time up to the scheduled replacement time for that part.

Items/Conditions Not Covered:

Not all product failures or malfunctions that occur during the warranty period are defects in materials or workmanship. The items / conditions listed below are not covered by this warranty:

- Product failures which result from the use of non-Toro replacement parts, or from installation and use of add-on, modified, or unapproved accessories are not covered.
- Product failures which result from failure to perform required maintenance and/or adjustments are not covered.
- Product failures which result from operating the Product in an abusive, negligent or reckless manner are not covered.

- This warranty does not apply to parts subject to consumption through use unless found to be defective. Examples of parts which are consumed, or used up, during normal Product operation include, but are not limited to, blades, reels, bedknives, tines, spark plugs, castor wheels, tires, filters, belts, etc.
- This warranty does not apply to failures caused by outside influence. Items considered to be outside influence include, but are not limited to, weather, storage practices, contamination, use of unapproved coolants, lubricants, additives, or chemicals, etc.
- This warranty does not apply to normal "wear and tear" items. Normal "Wear and Tear" includes, but is not limited to, damage to seats due to wear or abrasion, worn painted surfaces, scratched decals or windows, etc.

Other Legal Disclaimers:

The above remedy of product defects through repair by an authorized distributor or dealer is the purchaser's sole remedy for any defect. This warranty gives you specific legal rights, and you may also have other rights which vary from state to state.

Except for the Emissions warranty referenced below, if applicable, there is no other express warranty. All implied warranties of merchantability and fitness for use are limited to the duration of the express warranty.

Some states do not allow limitations on how long an implied warranty lasts, so the above limitation may not apply to you.

The Toro Company is not liable for indirect, incidental or consequential damages in connection with the use of the Product, including any cost or expense of providing substitute Product or service during periods of malfunction or non-use.

Some states do not allow the exclusion of incidental or consequential damages, so the above exclusion may not apply to you.

Note to California residents: The Emissions Control System on your Product may be covered by a separate warranty meeting requirements established by the U.S. Environmental Protection Agency (EPA), or the California Air Resources Board (CARB). The hour limitations set forth above do not apply to the Emissions Control System Warranty. Refer to the California Emission Control Warranty Statement printed in your Owner's Manual or contained in the engine manufacturer's documentation for details.