



FORM NO. 95-4837

MODEL NO. 44020 - 70001 & UP

OPERATOR'S
MANUAL

TURF SWEEPER 5400HL

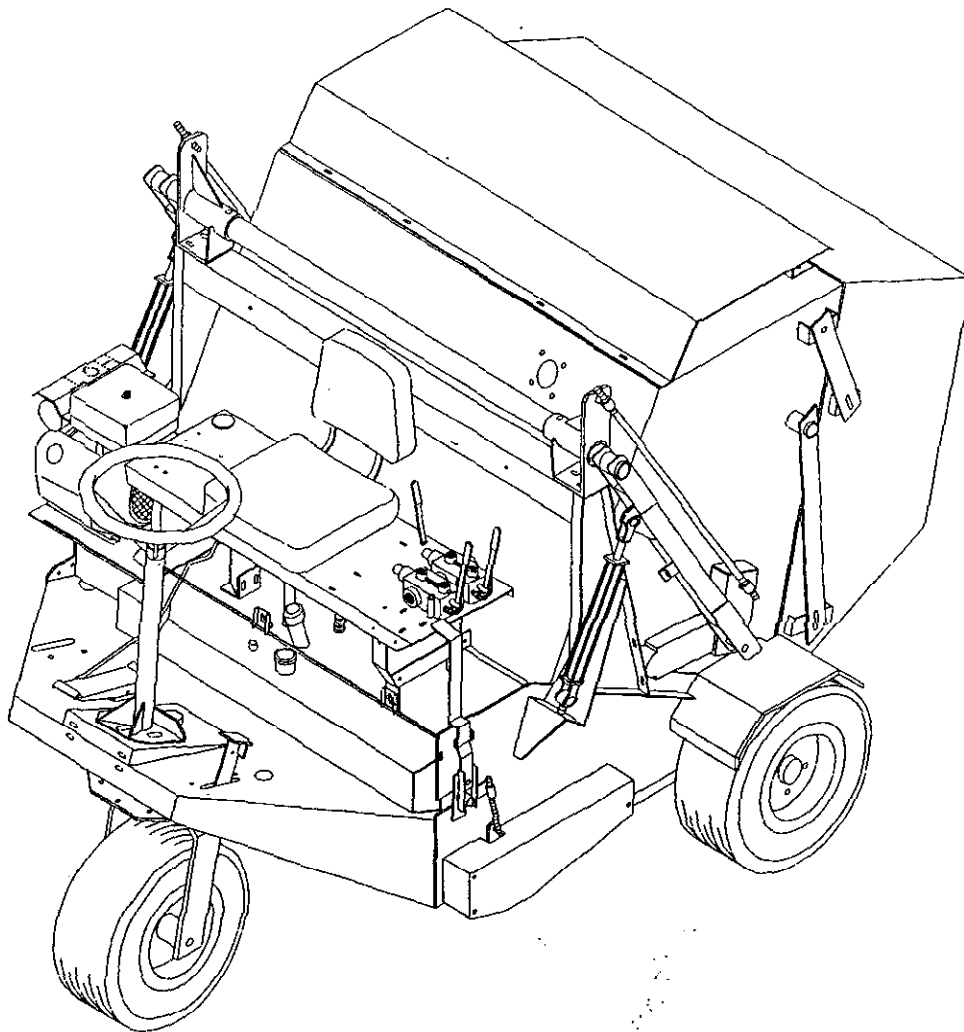

FOREWORD

Thank you for buying a high quality Toro turf care product. To get the best performance from this machine, operate and maintain it according to the instructions in this manual.

Toro also wants to stress the importance of safety. You and anyone else using or maintaining this machine are strongly urged to read this manual, especially all the safety instructions.

DANGER, WARNING and CAUTION, used with the triangular safety alert symbol, highlight safety messages. Always read and understand these messages because they relate to personal injury and your safety.

If you ever need help or have questions about your new Toro turf care product, contact your local Authorized Toro Distributor. The Toro Distributor has a complete supply of replacement parts, a full line of accessories and a professional service staff to support you. Keep your Toro all Toro. Buy genuine Toro parts and accessories.

TABLE OF CONTENTS

	Page		Page
SAFETY INSTRUCTIONS	3 - 5	Chain Tension	18
SAFETY AND INSTRUCTION DECALS ...	6 - 8	Sweeper Reels Leveling & Height Adjustment	18
SPECIFICATIONS	9	Drive Belt Adjustment	19
BEFORE OPERATING	10 - 11	Belt Tension	19
Check Tire Pressure	10	Adjusting Parking Brake Shoes	20
Check Crankcase Oil	10	Set Park Brake Pedal Stop	20
Fill Fuel Tank	10	Bleeding Brakes	21
Check Hydraulic System Oil	11	Adjusting Traction Pedal	21
Check Torque Of Wheel Nuts	11	Belt Stop Pin Adjustments	22
CONTROLS	12 - 14	Steering System	22
OPERATING INSTRUCTIONS	15	HYDRAULIC SCHEMATIC	23
LUBRICATION	16	TROUBLESHOOTING	24
MAINTENANCE	17 - 21	STORAGE	25
Changing Hydraulic Oil & Filter	17	IDENTIFICATION AND ORDERING	25
Checking Hydraulic Lines & Hoses	17	MAINTENANCE SCHEDULE	26 - 27
Wheel Motor Nut Torque	17	WARRANTY	Back Cover
Timing Chain Maintenance	17		

SAFETY INSTRUCTIONS

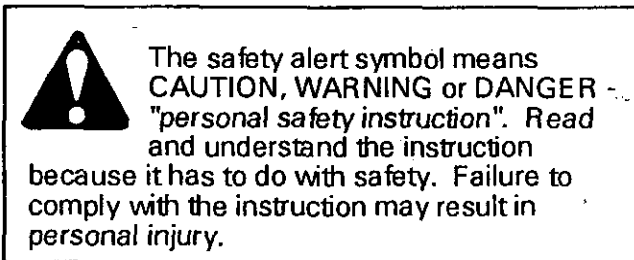

BEFORE OPERATING

1. Read and understand the contents of this manual before starting and operating the machine. Become familiar with all controls and know how to stop quickly. A free replacement manual is available by sending complete Model and Serial Number to:

The Toro Company
8111 Lyndale Avenue South
Minneapolis, MN, 55420

2. Do not allow children to operate the machine. Do not allow adults to operate the machine without proper instruction.

3. Never operate the machine while under the influence of drugs or alcohol.

4. Keep all shields and safety devices in place. If a shield, safety device or decal becomes damaged, malfunctioning or illegible, repair or replace it before operation is commenced. Also tighten loose nuts, bolts to ensure machine is in safe operating condition.

5. Before each use, tighten all bolts and nuts.

6. Do not alter this equipment in any manner which may cause hazardous conditions.

7. Fill gas tank before starting the engine. Avoid spilling any gas. Since gas is flammable, handle it carefully.

A. Use a approved fuel container.

B. Do not fill tank when engine is hot or running.

C. Do not smoke while handling fuel.

D. Fill tank outdoors and up to about one inch (25 mm) from the top of the tank.

E. Wipe up any spilled fuel.

SAFETY INSTRUCTIONS (Continued)

WHILE OPERATING



DANGER

ROTATING MEMBERS CAN CAUSE SERIOUS PERSONAL INJURY

- Keep hands and feet away from reel area.

8. Sit on seat when starting the engine and operating machine.

9. Before starting engine:

A. Engage parking brake.

B. Make sure traction pedal is in neutral.

C. After engine is started, release parking brake and keep foot off traction pedal. Machine must not move. If movement is evident, the neutral mechanism is adjusted incorrectly; therefore, shut off and adjust until machine does not move when traction pedal is released.

10. Do not run the engine in a confined area without adequate ventilation. Exhaust fumes are hazardous and could possibly be deadly.

11. Maximum seating is one person; therefore never carry passengers.

12. Do not touch engine, muffler or radiator while engine is running or soon after it is stopped. These areas could be hot enough to cause a burn.

13. Using the machine demands attention, and to prevent loss of control:

A. Operate only in daylight or when there is good artificial light.

B. Drive slowly.

C. Watch for holes or other hazards.

D. Look behind machine before backing up.

E. Do not drive close to a sand trap, ditch, creek or other hazard.

F. Reduce speed when making sharp turns and when turning on a hillside.

G. Avoid sudden stops and starts.

14. Operator must be skilled and trained in how to drive on hillsides. Failure to use caution on slopes or hills may cause loss of control possibly resulting in personal injury or death.

15. If engine stalls or machine loses headway and cannot make it to the top of a slope, do not turn machine around. Always back slowly straight down the slope.

16. Before getting off seat:

A. Move traction pedal to neutral position and remove foot from pedal.

B. Set the parking brake.

C. Shut the engine off and remove key from ignition switch. Wait for all movement to stop before getting off seat.



DANGER

MOVING HOPPER AND DUMPED DEBRIS CAN CAUSE SERIOUS PERSONAL INJURY

- Stay clear of hopper while machine is backing or dumping.
- Stay clear of moving parts while hopper is moving up or down

WHILE DUMPING

17. **NEVER** operate hopper controls while standing beside machine.

18. Keep bystanders a safe distance from hopper when dumping debris. Use care when backing machine.

19. Dump hopper only in area clear of overhead wires and other obstructions.

20. **NEVER** dump hopper on a slope. Always dump hopper on level ground.

SAFETY INSTRUCTIONS (Continued)

MAINTENANCE

21. Remove the key from the ignition switch to prevent accidental starting of the engine when servicing, adjusting or storing the machine.

22. If major repairs are ever needed or assistance desired, contact an Authorized TORO Distributor.

23. Make sure machine is in safe operating condition by keeping nuts, bolts and screws tight.

24. To reduce potential fire hazard, keep the engine free of excessive grease, grass, leaves and accumulations of dirt.

25. Make sure all hydraulic line connectors are tight, and all hydraulic hoses and lines are in good condition before applying pressure to the system.

26. Keep body and hands away from pin hole leaks or nozzles that eject hydraulic fluid under high pressure. Use paper or cardboard, not hands, to search for leaks. Hydraulic fluid escaping under pressure can have sufficient force to penetrate skin and do serious damage. If fluid is injected into the skin it must be surgically removed within a few hours by a doctor familiar with this form of injury or gangrene may result.

27. Do not over speed the engine by changing the governor settings. Maximum engine speed with no load is 3200 RPM. To ensure safety and accuracy, have an Authorized TORO Distributor check maximum engine speed with a tachometer.

28. Engine must be shut off before checking oil or adding oil to the crankcase.

29. **ALWAYS** torque the nut on the wheel motors to 230 - 250 ft. lbs. when servicing.



WARNING

TO MINIMIZE THE RISK OF PERSONAL INJURY OR DEATH

- Always attach the cylinder safety stop to the shaft of the cylinder when working under the hopper.

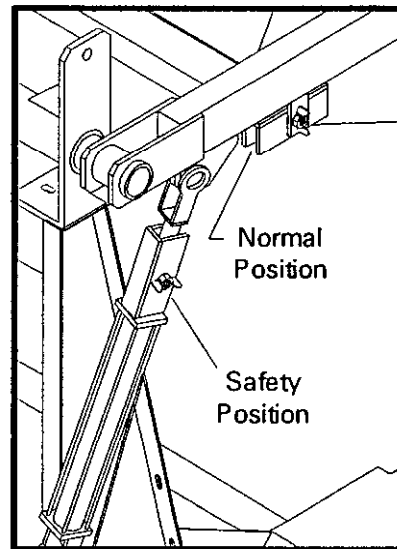

SAFETY AND INSTRUCTION DECALS

The following safety and instruction decals are installed on the unit. Replace any decals that becomes damaged or illegible. Part numbers for decals are listed below and in your Parts Catalog. Order replacements from your Authorized Toro Distributor.

DANGER

TO MINIMIZE THE RISK OF PERSONAL INJURY OR DEATH.

- LOS OPERADORES DEBEN ESTAR MUY BIEN CAPACITADOS EN UNA OPERACION SEGURA.
 - READ AND UNDERSTAND OPERATOR'S MANUAL BEFORE OPERATING THIS MACHINE.
 - KEEP HANDS AND FEET AWAY FROM SWEEPER REELS WHILE MACHINE IS RUNNING.
 - DO NOT OPERATE WITHOUT BELT, PULLEY AND CHAIN GUARDS IN PLACE.
 - STOP ENGINE BEFORE LEAVING OPERATOR'S POSITION. DO NOT OPERATE HOPPER CONTROLS WHILE STANDING BESIDE MACHINE.
 - KEEP BYSTANDERS A SAFE DISTANCE FROM HOPPER WHEN DUMPING DEBRIS. USE CARE WHEN BACKING MACHINE.
 - DUMP HOPPER ONLY IN AREA CLEAR OF OVERHEAD WIRES AND OTHER OBSTRUCTIONS.
 - NEVER DUMP HOPPER ON A SLOPE. ALWAYS DUMP HOPPER ON LEVEL GROUND.
- REPLACEMENT MANUAL AVAILABLE BY SENDING COMPLETE MODEL NUMBER TO:
THE TORO COMPANY, 100 INDUSTRIAL PARKWAY, INDUSTRIAL AIRPORT, KS 66031

01-506-0070

ON TOWER
(Part No. 01-506-0070)

DANGER

USE EXTREME CAUTION ON HILLS AND SLOPES

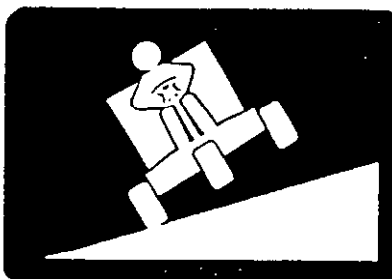
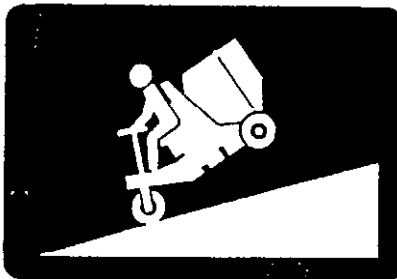

TIP OVER CAN CAUSE SERIOUS INJURY OR DEATH

- NEVER OPERATE ON STEEP SLOPES.
- NEVER ATTEMPT TO DUMP THE HOPPER ON A SLOPE. ALWAYS DUMP THE HOPPER ON LEVEL GROUND.
- SWEEP SLOPES UP AND DOWN, NEVER ACROSS THE FACE.
- WHEN GOING UPHILL OR DOWNHILL DO NOT STOP OR START SUDDENLY.
- GO SLOW AND AVOID SHARP TURNS.
- STAY ALERT FOR HOLES IN THE TERRAIN OR OTHER HIDDEN HAZARDS. TO AVOID TIPPING OR LOSS OF CONTROL, DO NOT DRIVE CLOSE TO A DITCH, CREEK, OR DROP OFF.
- IF MACHINE STOPS GOING UP HILL, DISENGAGE REELS OR BRUSHES AND BACK SLOWLY DOWN HILL. DO NOT ATTEMPT TO TURN.
- OPERATOR MUST BE SKILLED AND TRAINED IN SLOPE OPERATION - READ OPERATOR'S MANUAL.

01-506-0090

BELOW STEERING COLUMN
(Part No. 01-506-0090)

SAFETY AND INSTRUCTION DECALS (Continued)

! DANGER

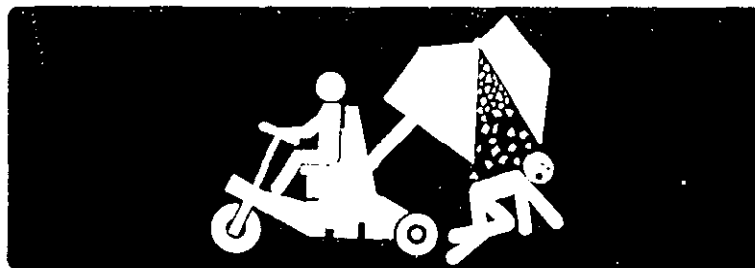

**MOVING HOPPER AND DUMPED DEBRIS
CAN CAUSE SERIOUS PERSONAL INJURY**

- STAY CLEAR OF HOPPER WHILE MACHINE IS BACKING OR DUMPING.
- STAY CLEAR OF MOVING PARTS WHILE HOPPER IS MOVING UP OR DOWN.

01-506-0060

SIDES OF HOPPER DOOR
(Part No. 01-506-0060)

! DANGER

ROTATING CHAINS AND SPROCKETS CAN
CAUSE SERIOUS PERSONAL INJURY
DO NOT OPERATE MACHINE UNLESS ALL
GUARDS ARE IN PLACE



01-506-0050

ON CHAIN GUARD
(Part No. 01-506-0050)

! DANGER

- ROTATING PULLEYS AND BELTS CAN CAUSE
SERIOUS INJURY.
- DO NOT OPERATE MACHINE UNLESS ALL
GUARDS ARE IN PLACE.



01-506-0040

ON BELT GUARD
(Part No. 01-506-0040)



! DANGER

ROTATING MEMBERS CAN
CAUSE SERIOUS PERSONAL
INJURY

- KEEP HANDS AND FEET AWAY
FROM REEL AREA.

01-506-0080

ON CHAIN & BELT GUARDS
(Part No. 01-506-0080)

SAFETY AND INSTRUCTION DECALS (Continued)

⚠ DANGER

TO AVOID FIRE HAZARD:

- KEEP LEAVES, GRASS AND OTHER COMBUSTABLE MATERIAL AWAY FROM HOT ENGINE MUFFLER.



01-506-0030

ON ENGINE
(Part No. 01-506-0030)

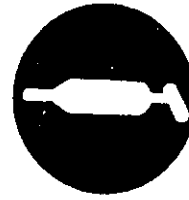

NEAR GREASE POINTS
(Part No. 01-506-0550)

TRACTION PEDAL

FORWARD

REVERSE

01-506-0570

BY FOOT PEDAL
(Part No. 01-506-0570)

GAS ONLY

71-3730

BY GAS CAP
(Part No. 01-506-0460)

HYDRAULIC OIL ONLY

10W30 OR 10W40

BY OIL FILL
(Part No. 01-506-0560)

P PARKING BRAKE

TO APPLY PARKING BRAKE:

- DEPRESS BRAKE PEDAL.
- BRAKE LOCK WILL LATCH INTO SLOTS.

TO DISENGAGE PARKING BRAKE:

- DEPRESS THE BRAKE LOCK TO RELEASE PEDAL.
- BRAKE PEDAL WILL SPRING BACK TO NEUTRAL.

01-506-0960

BY PARKING BRAKE
(Part No. 01-506-0980)

CLOSE HOPPER DOOR OPEN

LOWER HOPPER LIFT RAISE

01-506-0170

BY VALVES
(Part No. 01-506-0170)

NO RIDERS

75-5190

ON GAS TANK
(Part No. 01-506-0540)

SPECIFICATIONS

SWEEPING WIDTH: 60" (5 feet)

ENGINE: 24 HP Onan

FRAME: All welded steel construction

PICK UP FINGERS: Abrasion resistant, high resistance rubber, 140 per machine.

PICK UP: Mechanical, 2 reels, timed, counter rotating, with "Sure Grip" rubber fingers.

HOPPER: 3 cubic yards.

DUMP: Hydraulic, 5-1/2 ft. height, activated from operators seat

BEARINGS: Self sealed throughout

BRAKES: Hydraulic brake with parking brake.

DRIVE TO WHEELS: Hydraulic system - flex coupler from engine to hydraulic pump, then to two wheel motors.

TIRES: Front & Rear - 18.00 x 8.5 - 4 ply (22 PSI)

DIMENSIONS: Width - 80"
Length - 100"
Height - 66"

REEL HEIGHT ADJUSTMENT: Linkage to reels that pivot, instant positive adjustment from operator's seat.

SHIPPING WEIGHT: 2130 lbs.

OPTIONS: Thatcher, Curb Broom, Donaldson Air Cleaner Kit, Rubber Finger Puller.

BEFORE OPERATING

CHECK TIRE PRESSURE

Check tire pressure before each use. Inflate to 22 PSI.

CHECK CRANKCASE OIL

Oil recommendations are: SAE 10W30 SF-CC

The engine is shipped with 2-1/2 quarts of oil in the crankcase; however, level of oil must be checked before and after the engine is first started.

1. Position the sweeper on a level surface and make sure engine is off.
2. Remove the dipstick and wipe it with a clean rag. Push dipstick down into the tube and ensure it is fully seated. Pull dipstick out of the tube and check level of oil. If oil level is low add enough oil to raise level on top notch on dipstick.

IMPORTANT: Check level of oil after every 5 hours of operation or daily. Change oil after every 50 hours of operation and change the oil filter after the first 50 hours and every 100 hours thereafter. Change oil and filter more frequently when engine is operated in extremely dusty conditions.

FILL FUEL TANK WITH GASOLINE (Fig. 1)

THE TORO COMPANY STRONGLY RECOMMENDS THE USE OF FRESH CLEAN, UNLEADED REGULAR GRADE GASOLINE IN TORO GASOLINE POWERED PRODUCTS. UNLEADED GASOLINE BURNS CLEANER, EXTENDS LIFE, AND PROMOTES GOOD STARTING BY REDUCING THE BUILD-UP OF COMBUSTION CHAMBER DEPOSITS.

Note: Do not mix oil with gasoline. **Never** use methanol, gasoline containing methanol, gasohol, gasoline additives, premium gasoline, or white gas because engine/fuel system damage could result.



DANGER

Because gasoline is flammable, caution must be used when storing or handling it. Do not fill fuel tank while engine is running, hot or when machine is in an enclosed area. Vapors may build up and be ignited by a spark or flame source many feet away. **DO NOT SMOKE** while filling the fuel tank to prevent possibility of explosion. Always fill fuel tank outside and wipe up any spilled gasoline before starting engine. Use a funnel or spout to prevent spilling gasoline before starting engine and fill tank to about 1 inch (25 mm) below the filler neck. Store gasoline in a clean safety approved container and keep the cap in place on the container. Keep gasoline in a cool, well ventilated place; never in an enclosed area such as a hot storage shed. To assure volatility, do not buy more than a 30 day supply of gasoline.

Gasoline is a fuel for internal combustion engines; therefore, do not use it for any other purpose. Since many children like the smell of gas, keep it out of their reach because the fumes are explosive and dangerous to inhale.

1. Remove the cap from the fuel tank and fill the 5 gallon tank to within 1 inch (25 mm) from the top with unleaded gasoline. Install fuel cap tightly.
2. Wipe up any gasoline that may have spilled to prevent a fire hazard.

BEFORE OPERATING (Continued)

CHECK HYDRAULIC SYSTEM OIL (Fig. 1)

The hydraulic system is designed to operate on any high quality detergent. Oil recommendations are: 10W30 SF-CC

1. Position the sweeper on a level surface and make sure engine is off.
2. Pull out the dipstick from the oil filler tube. Check the level indicated on the dipstick.
3. If low add sufficient oil to bring to the "Full" mark. Do Not overfill.

IMPORTANT: When adding oil to the hydraulic system, use a funnel with a fine screen - 200 mesh - and ensure funnel and oil are immaculately clean. This procedure prevents accidental contamination of the hydraulic system which will damage the hydraulic system.

CHECK TORQUE OF WHEEL NUTS



WARNING

Failure to maintain proper torque could result in failure or loss of wheel and may result in personal injury. Torque rear wheel nuts to 60 - 70 ft. lbs.

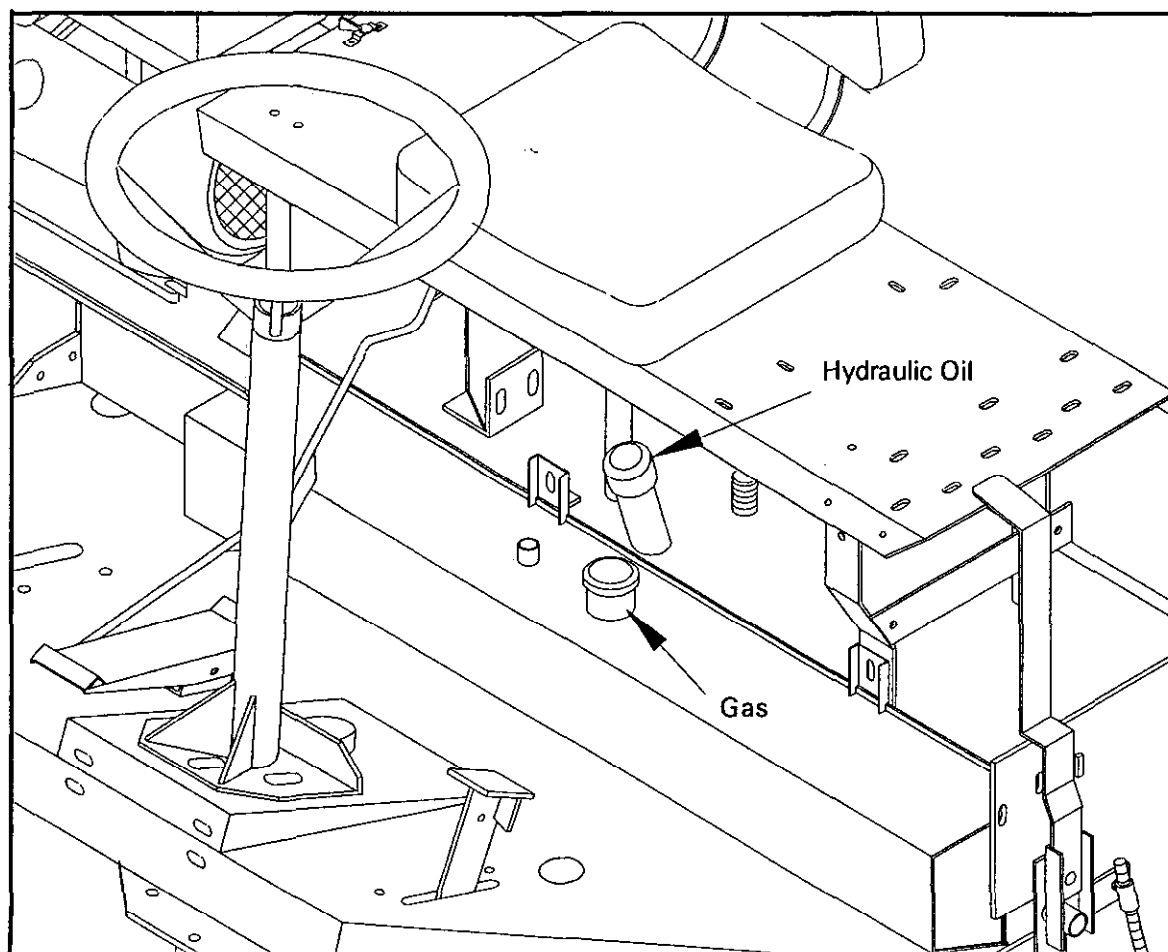

Figure 1

CONTROLS

THROTTLE CONTROL (Fig. 2)

Throttle is used to operate engine at various speeds. Moving throttle forward increases engine speed; backwards decreases engine speed. The throttle regulates the speed of the sweeper reels and in conjunction with traction pedal controls ground speed of the sweeper.

KEY SWITCH

The key switch, which is used to start and stop the engine, has two positions: "OFF" and "ON". Rotate key clockwise to engage starter motor. When engine starts, release key and it will move automatically to the "ON" position. To shut engine off, rotate key counterclockwise to the "OFF" position.

TRACTION PEDAL (Fig. 2)

The traction pedal has two functions; one to make the machine move forward, the other to make it move backward. Using the heel and toe of the right foot, depress top of pedal to move forward and bottom of pedal to move backward. Ground speed is proportionate to how far pedal is depressed. For maximum ground speed with no load, traction pedal must be fully depressed while throttle is in full position.

Maximum forward speed is approximately 9 mph. Maximum forward speed while sweeping is 9 mph. If sweeping wet debris or a thick layer of material, slower speeds may need to be used.



CAUTION

When foot is removed from traction pedal, machine should stop; it must not creep in either direction. If machine does creep, do not operate until neutral assembly has been repaired or adjusted; refer to Adjusting Traction Pedal.

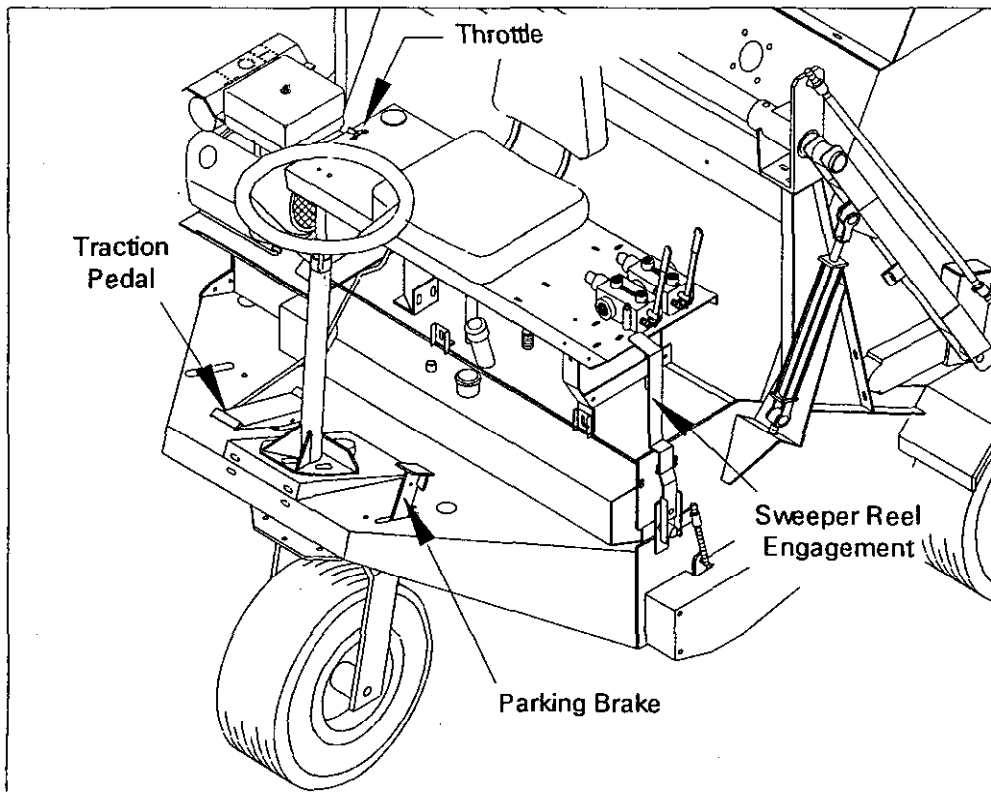

Figure 2

CONTROLS (Continued)

PARKING BRAKE (Fig. 2 & 3)



CAUTION

Whenever the engine is shut off, the parking brake must be engaged to prevent accidental movement of the machine.

To set: Lock the Brake Stop into position by placing the bottom of the Brake Stop into the slot of the Brake Stop Plate.

To release: Push down on the tab at the end of the Brake Stop.

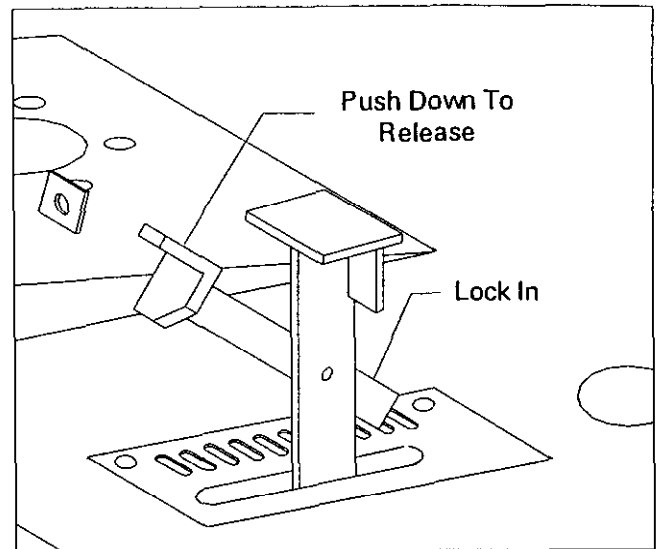

Figure 3



CAUTION

The hydrostatic transmission will not, at any time, act as a parking brake for the machine. To engage parking brake, always push down on the brake pedal and lock into position.

TOW VALVE KNOB (Fig. 4)

The tow valve knob is located in the rear of the Hydraulic Pump. In the horizontal position the handle is in the operating position. In a vertical position the handle is in the towing position.

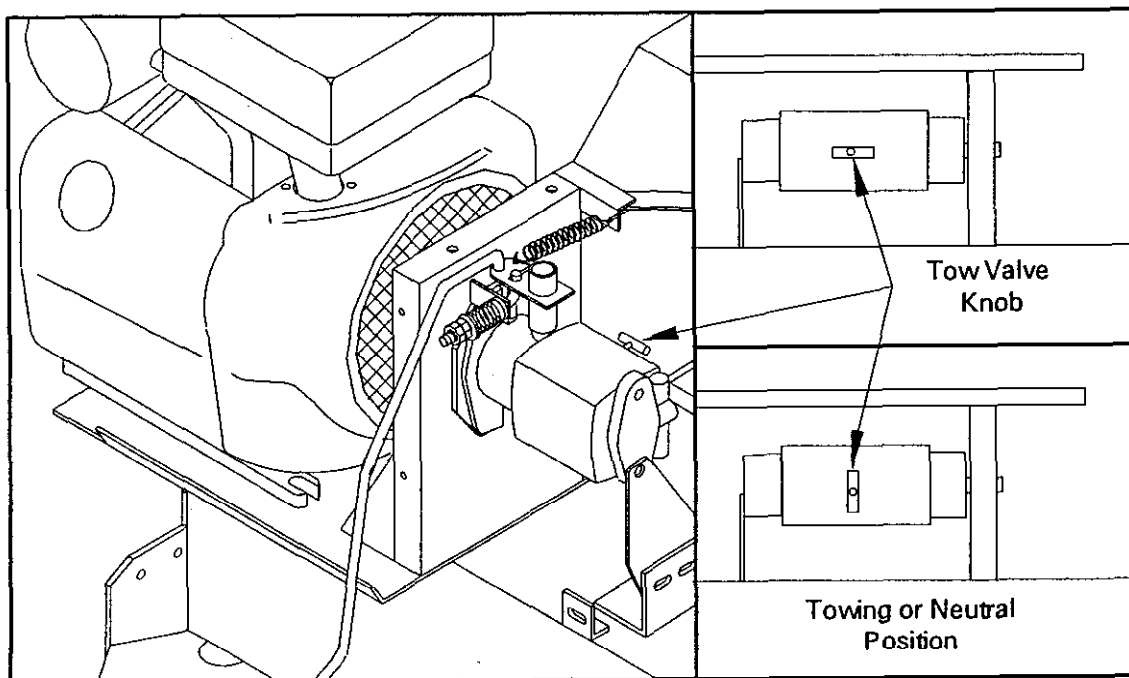

Figure 4

CONTROLS (Continued)

SWEEPER REEL HANDLE (Fig. 2 & 5)

The engagement of the sweeping reels is done with the Sweeper Reel Engagement Handle. The handle also sets the height of the fingers. There are three settings for finger height. The height of the fingers is set so the fingers touch the top of the turf. The first setting will set the fingers at 1-1/4" from the surface. The second setting sets the fingers at 1" and the third at 5/8" from the surface.

When transporting the sweeper attach the cotter pin in the hole on the pin of the Sweeper Reel handle to prevent it from coming out and accidentally engaging the reels and causing damage to the turf.

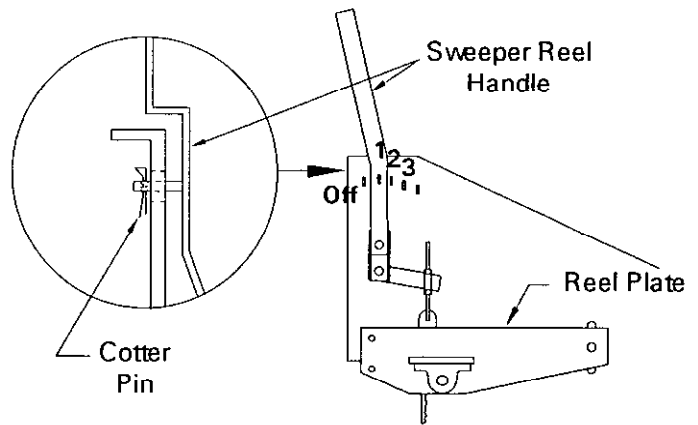

Figure 5

HOPPER DOOR (Fig. 6)

The hopper door is opened hydraulically with the valve control. Pushing the handle forward closes the door while pulling toward the operator opens the door.

HOPPER LIFT (Fig. 6)

The hopper is lifted hydraulically with the valve control. Pushing the handle forward brings the hopper down toward the frame while pulling toward the operator lift the hopper to dumping position.

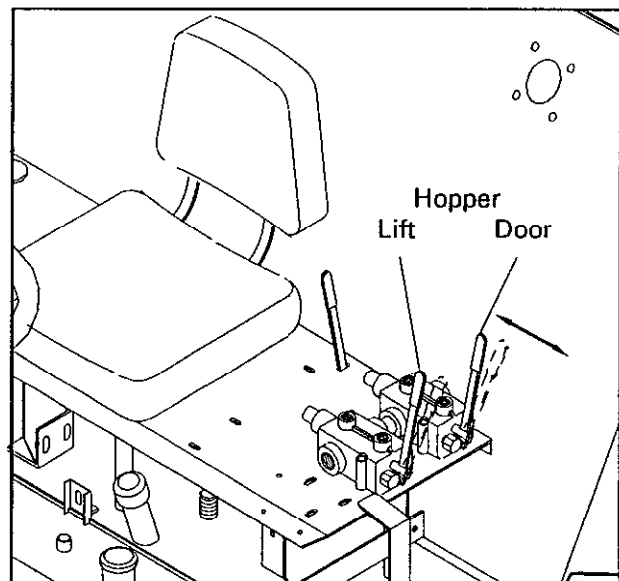

Figure 6

OPERATING INSTRUCTIONS

1. Place the unit on a level surface and apply the parking brake.
2. Start engine with the throttle at 1/2 open and choke pulled out. When engine starts, push in the choke gradually.
3. Release the parking brake.
4. Press the Traction Pedal forward to move forward. Press down on the heel of the foot to move backward. Practice moving both ways to get a feel of the machine. For quick braking quickly depress the heel of the traction pedal until hydrostatic transmission reaches neutral.



CAUTION

For emergency braking, completely remove foot from the traction pedal.

5. Run engine to 3/4 throttle.
6. As you are moving forward engage the Sweeper Reel engagement control to engage the finger reels.

IMPORTANT: NEVER run the reels in one spot for longer than a minute because the turf will be damaged.

WHILE SWEEPING



DANGER

TIP OVER CAN CAUSE SERIOUS INJURY OR DEATH

Never operate on steep slopes.

Sweep slopes up and down, **never** across the face.

When going uphill or downhill, do not stop or start suddenly.

Stay alert for holes in the terrain or other hidden hazards. To avoid tipping or loss of control, do not drive close to a ditch, creek or drop off.

If machine stops going uphill, disengage reels and back slowly downhill. Do not attempt to turn.

1. When the hopper is full, disengage reels and transport to dumping area. The sight gage on the hopper can be used to check for a full hopper. When the hopper is full the sweeper will no longer pickup as efficiently, leaving or throwing material back on the ground.

DUMPING THE HOPPER



DANGER

TO MINIMIZE THE RISK OF PERSONAL INJURY OR DEATH

Never dump hopper on a slope. Always dump hopper on level ground.

Dump only in area clear of overhead wires and other obstructions.

Do not operate hopper controls while standing beside machine.

1. Engage the hopper lift valve control to lift the hopper.
2. When the hopper is fully lifted, engage the hopper door valve control to open the door.
3. When hopper is empty, slowly close the door and return the hopper to the closed position.

LUBRICATION

BEARINGS (Fig. 7)

The sweeper has four self sealing bearings that must be lubricated with a No. 2 Lithium based grease. If the optional Thatcher is installed, there is also a bearing on each end of the blade shaft.

IMPORTANT: Lubricate the bearings as often as necessary to maintain a slight leakage on the seals. Too much grease can cause overheating.

WHEELS AND WHEEL BEARINGS (Fig. 7)

Grease fittings and wheel bearings every 100 operating hours. Use a No. 2 Lithium based grease.

DRIVE CHAIN (Fig. 7)

Always maintain a heavy coat of grease on the drive chain.

GREASE FITTINGS (Fig. 7)

There are four grease fittings that must be lubricated with a No. 2 Lithium based grease. Grease fittings every 100 hours of operation or as needed to maintain a slight leakage at the points.

STEERING GEARS & HUB (Fig. 7)

The steering gears must have a coating of grease on them at all times. The hub should be greased every 100 hours of operation. Use a No. 2 Lithium based grease.

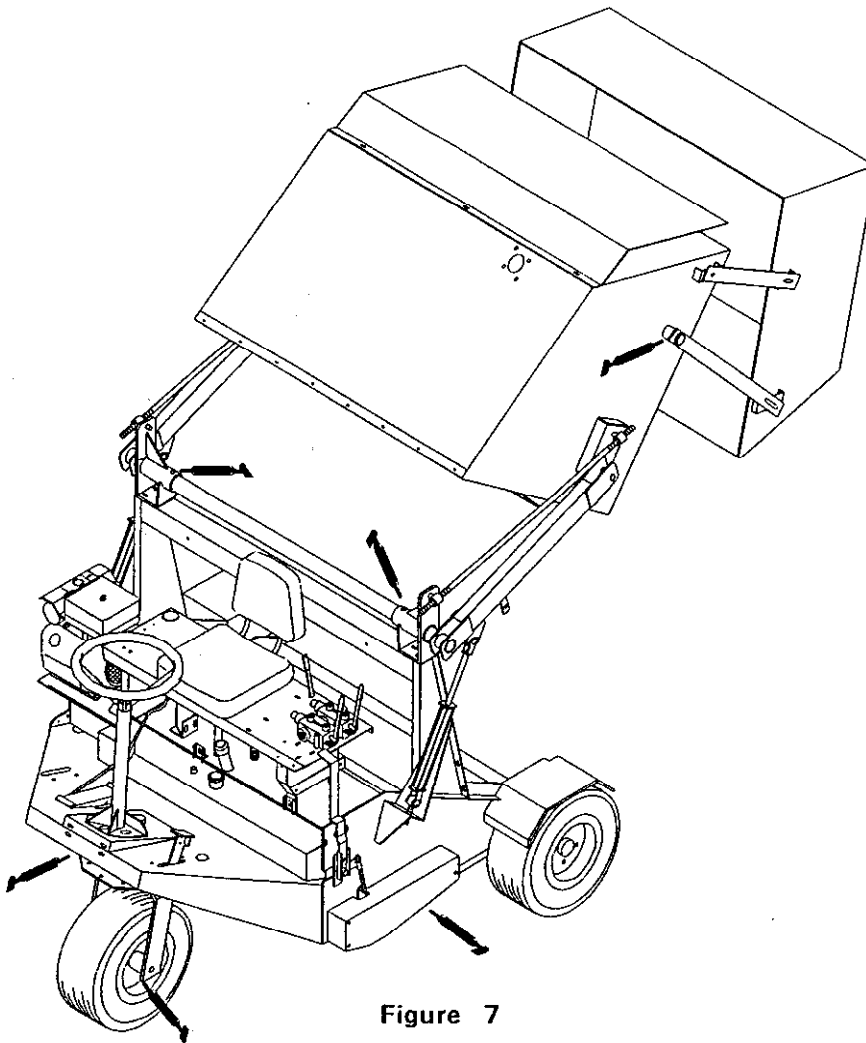

Figure 7

MAINTENANCE

CHANGING HYDRAULIC OIL AND FILTER

Normally, change hydraulic oil and filter after every 500 operating hours. If oil becomes contaminated, contact your local TORO distributor because the system must be flushed. Contaminated oil looks milky or black when compared to clean oil.

1. Remove drain plug from reservoir and let hydraulic oil flow into drain pan. Reinstall and tighten plug when hydraulic oil stops draining.
2. Clean area around filter mounting area.
3. Fill the replacement filter with 10W30 SF-CC motor oil, and lubricate the sealing gasket and hand turn until gasket contacts filter head. Then tighten 3/4 turn further. Filter should now be seated.
4. Fill the hydraulic tank with approximately 12 gallons of 10W30 SF-CC motor oil.
5. Start the engine and run it at idle for 3 to 5 minutes to circulate the fluid and remove any air trapped in the system. Operate the hopper door and hopper lift valve control. Stop the engine and re-check the fluid level.

CHECKING HYDRAULIC LINES AND HOSES

After every 100 operating hours, check hydraulic lines and hoses for leaks, kinked lines, loose mounting supports, wear, loose fittings, weather deterioration and chemical deterioration. Make all necessary repairs before operating.



WARNING

Keep body and hands away from pin hole leaks or nozzles that eject high pressure hydraulic fluid. Use a cardboard or paper to find hydraulic leaks. Hydraulic fluid escaping under pressure can penetrate skin and cause injury. Fluid accidentally injected into the skin must be surgically removed within a few hours by a doctor familiar with this form of injury or gangrene may result.

WHEEL MOTOR NUT TORQUE (Fig. 8)

ALWAYS torque the nut on the wheel motor to 230 - 250 ft. lbs when servicing. Place the tabs of the nut on the outside as shown in Fig. 8. If the tabs are installed on the inside, against the hub, the nut cannot be torqued properly.

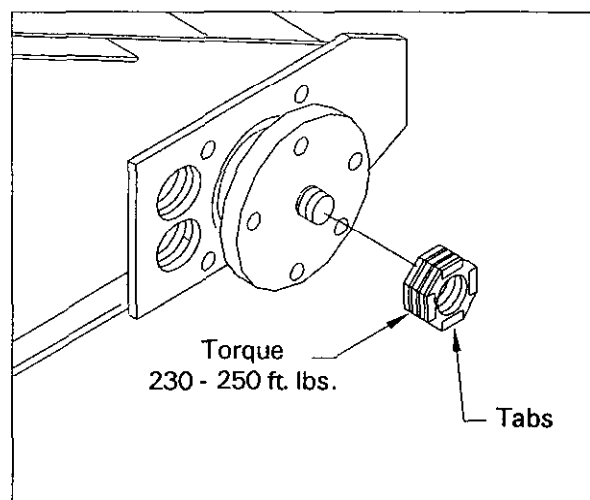

Figure 8

TIMING CHAIN MAINTENANCE (Fig. 9)

To prevent the fingers from hitting each other, reels should be set at a 45 degree position from each other.

1. Remove the chain guard.
2. Remove the connecting link from the chain.
3. Rotate the rear reel by hand until the reel is positioned as shown below.
4. Install the connecting link on the chain.
5. Install chain guard.

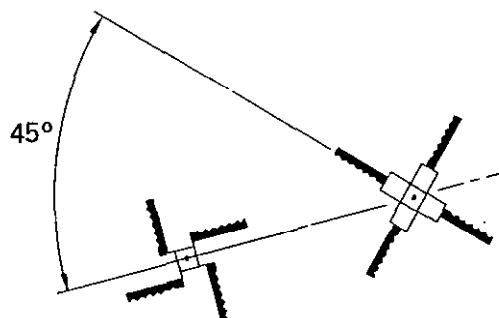

Figure 9

MAINTENANCE (Continued)

CHAIN TENSION (Fig. 10)

The rear idler sprocket is under spring tension to keep a constant tension on the reel drive chain. To increase tension, screw jam nut (A) clockwise, to decrease, turn counterclockwise. A 1/8" deflection is recommended. Do not over tighten because the chain will wear rapidly. Do not operate with a loose chain because the sprocket will wear rapidly.

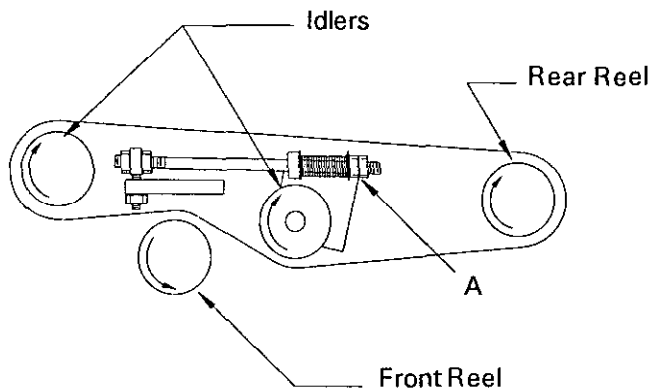

Figure 10

SWEEPER REELS LEVELING & HEIGHT ADJUSTMENT (Fig. 11)

The sweeper reels should be parallel with the bottom of the sweeper to maintain an even distance from the ground. The reels are set a 3/4" from ground level on both sides. This setting is standard and when lowered to "ON" position will accommodate most types of grasses. If the dimension is different or not correct from end to end, the nuts (A) may be used to correct it.

IMPORTANT After leveling sweeper reels, always check the tension of the reels drive belt for proper adjustment. See Drive Belt Adjustment.

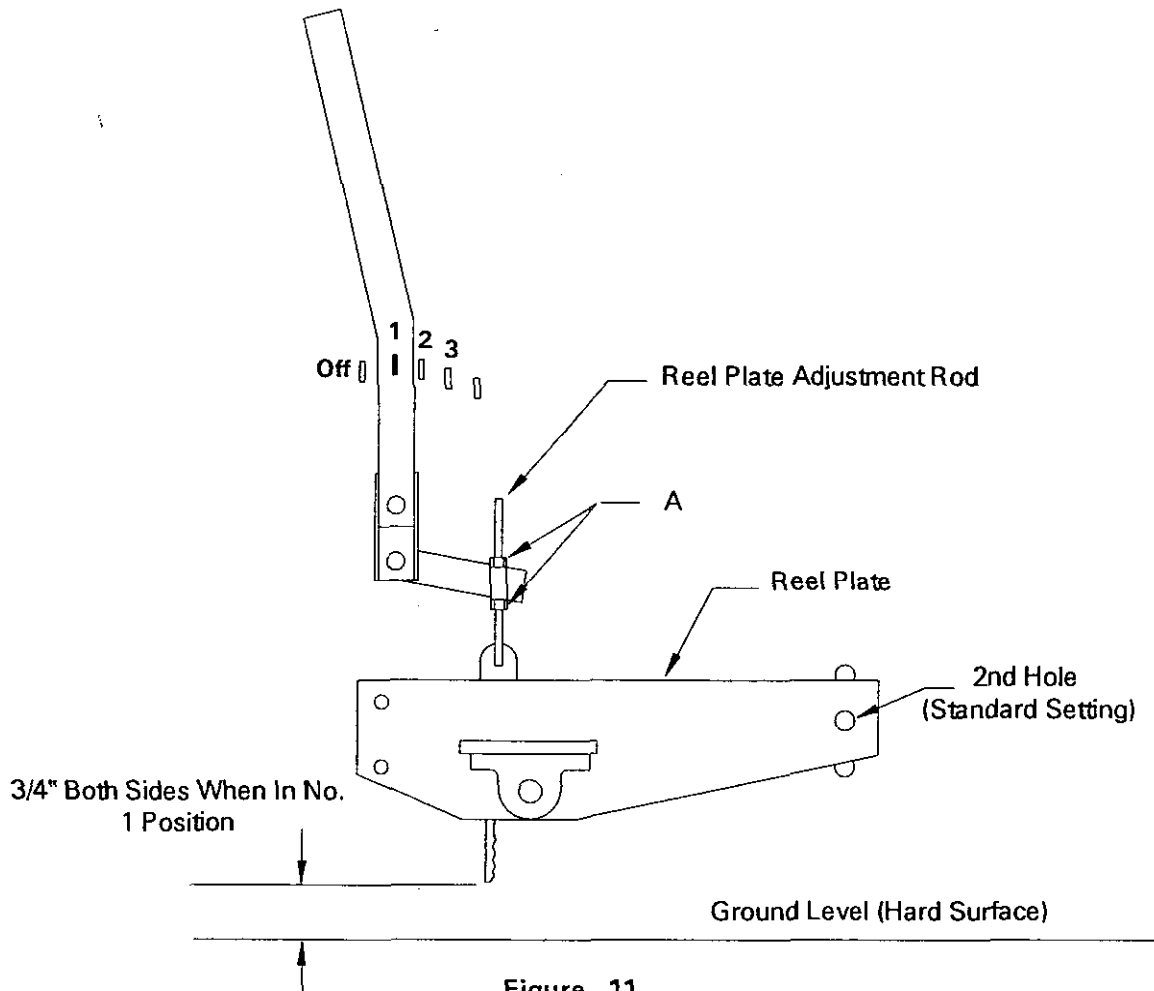

Figure 11

MAINTENANCE (Continued)

DRIVE BELT ADJUSTMENT (Fig. 12)

If Reels Fail To Engage: Adjust the idler disengaging bolt downward. The adjustment maybe necessary from time to time to compensate for wear and stretch on the drive belt.

If Reels Fail To Disengage: Adjust the idler disengaging bolt upward to move the idler pulley away from the drive belt.

BELT TENSION (Fig. 12)

The belt has 1/4" deflection with 5 lbs. of force when properly adjusted. To decrease tension, move the idler spring upward; downward to increase tension.

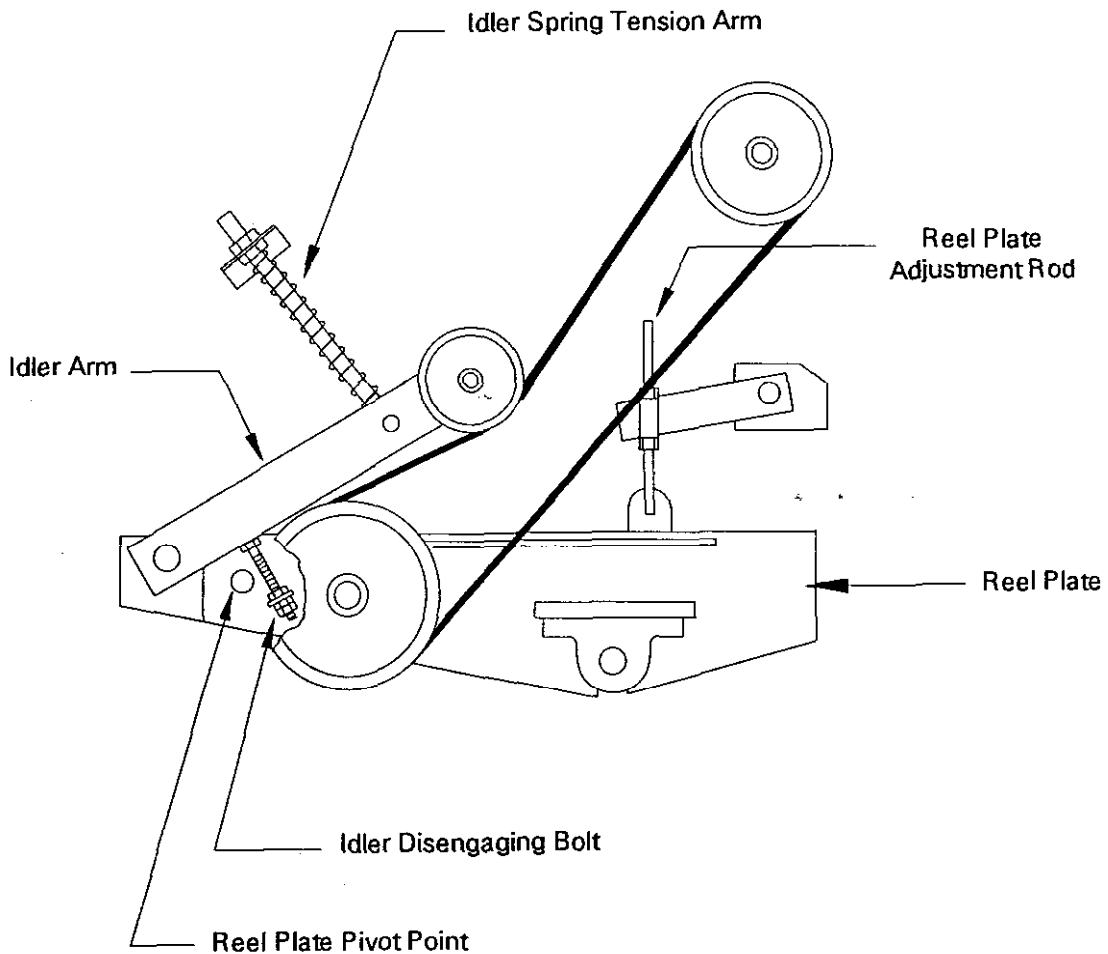

Figure 12

MAINTENANCE (Continued)

ADJUSTING PARKING BRAKE SHOES

The parking brake should be adjusted after the first 50 hours of operation.

The brakes should be adjusted in the following manner:

1. Park machine on a level surface and shut engine off.
2. Jack up one side of the machine in the front until front tire is off shop floor.



CAUTION

Support machine with jack stands to prevent it from falling accidentally.

3. With a screwdriver or standard adjusting tool rotate the starwheel of the adjuster assembly to expand the brake shoes.

4. Adjust the brake shoes out until the pressure of the linings against the drum makes the wheel very difficult to turn.

5. Rotate the starwheel in the opposite direction until the wheel turns freely with a slight lining drag.

6. Remove the jack and lower the wheel to the ground.

SET PARK BRAKE PEDAL STOP (Fig. 13)

7. Loosen the carriage bolt and nut on the Brake Pedal Stop.

8. Depress Foot Pedal forward until brake is in operating position.

9. Slide the Park Brake Pedal Stop downward until it hits against the Brake Pedal. Tighten the carriage bolt and nut.

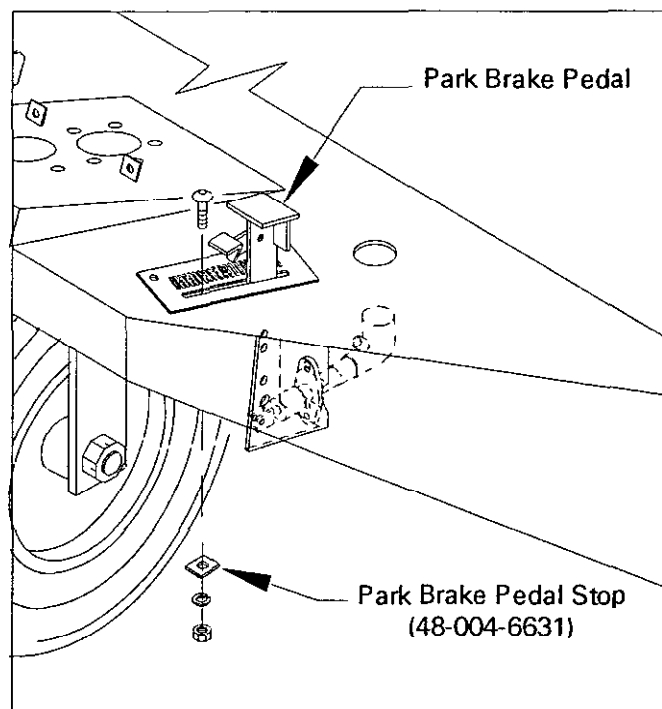

Figure 13

MAINTENANCE (Continued)

BLEEDING BRAKES

1. Slightly loosen bleeder nut on brake cylinder.
2. Engage Foot Pedal down slowly until in operating position and hold.
3. Tighten bleeder nut.

ADJUSTING TRACTION PEDAL (Fig. 14)



CAUTION

If the unit creeps forward or reverse when no pressure is applied to the foot pedal an adjustment must be made.

1. Park machine on a level surface and shut engine off. Depress the parking brake.
2. Jack up one side of the machine in the rear until rear tire is off shop floor.



CAUTION

Support machine with jack stands to prevent it from falling accidentally.

3. Repeat the process for the other rear tire also supporting with jack stands.

4. Start engine and run in IDLE position.
5. If rear tires are rotating forward, move the bottom (A) nut downward. If unit is rotating backward, move the top nut (B) upward.
6. Always tighten both nuts when final adjustments are completed.
7. Stop engine. Remove jack stands and lower machine to the shop floor.
8. Release parking brake. Test drive the machine to be sure it does not creep.

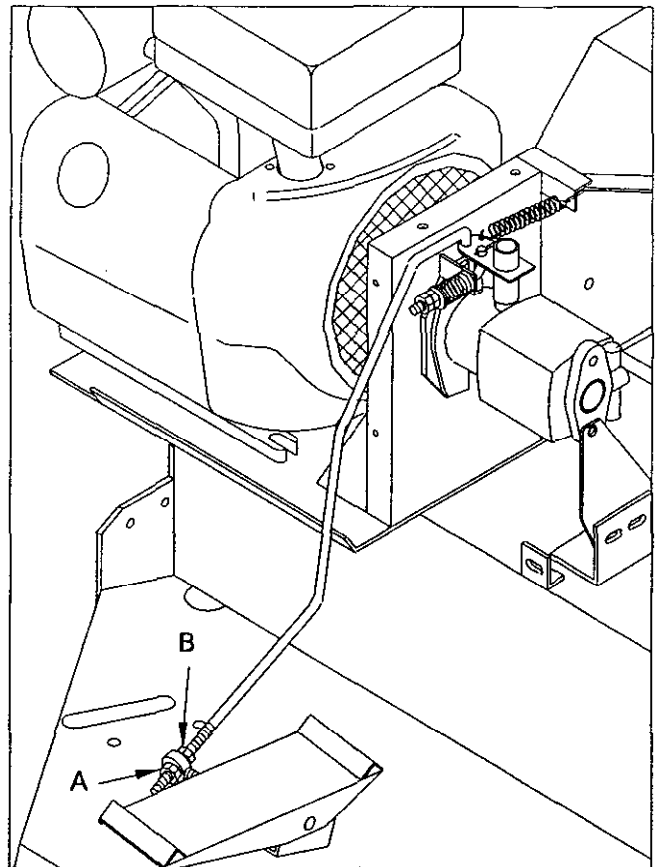

Figure 14

MAINTENANCE (Continued)

BELT STOP PIN ADJUSTMENTS (Fig. 15)

The purpose of the belt stop pins is to slow down and stop the drive belt when the Sweeper Reel lever is disengaged. Pin adjustments are maintained as follows:

1. With the engine off and key removed from ignition, place the Sweeper Reel Lever in the first (ON) position.
2. Loosen the nut on the back of the pin.
3. Adjust the belt stop pins so they are 1/16" to 1/8" from the outside of the drive belt.
4. Tighten nut.
5. Test the belts ability to stop. If the belt continues to run, repeat the process.

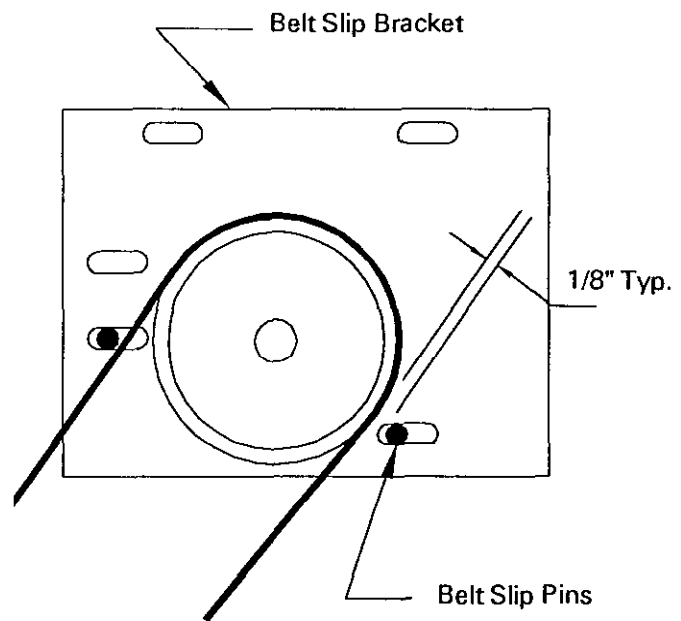

Figure 15

STEERING SYSTEM (Fig. 16)

When steering system is binding or excessive play in the column occurs:

1. Loosen the steering column hold down bolts.
2. If the steering has excessive play, move the adjustment bolts toward the steering column until the play is eliminated. The steering will be easy to turn with no play back and forth.
3. If the steering is binding, move the adjustment bolts away from the steering column until it turns freely.
4. Tighten hold down bolts.
5. Turn column from side to side and make sure it turns smoothly the complete rotation.

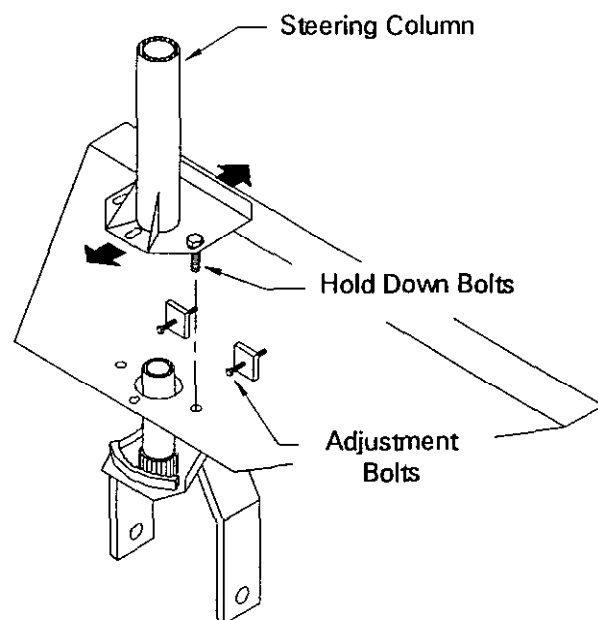
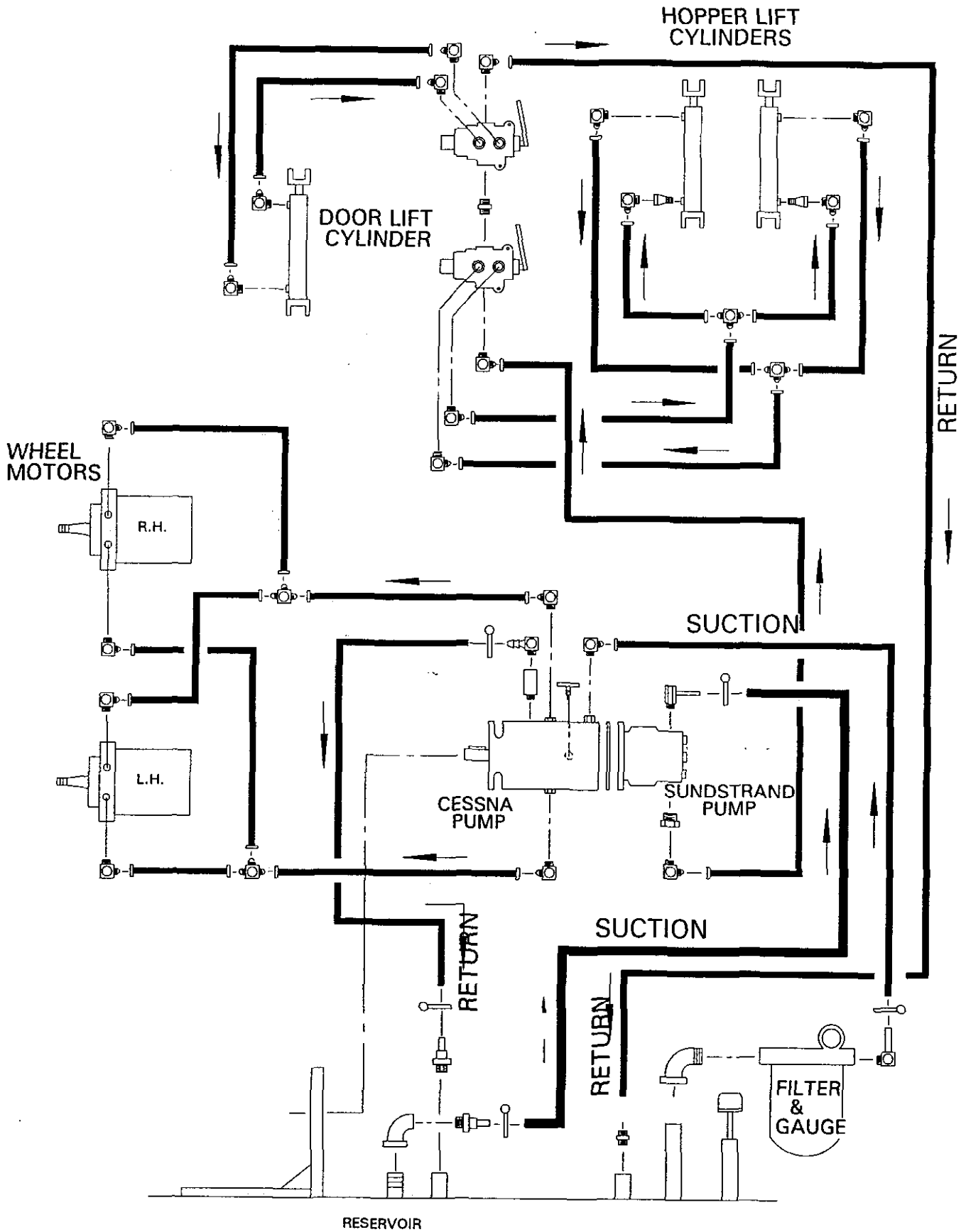

Figure 16

HYDRAULIC SCHEMATIC - 5400HL



TROUBLE SHOOTING

CONDITION	CAUSE	CORRECTION
<p>SWEEPER NOT PICKING UP</p>	<ul style="list-style-type: none"> • Missing or broken fingers. • The reels may not be timed properly. • Broken chain. • Check sprockets for sheared key. • Broken belt or improper tension. • Check sheaves for sheared key. • Finger height may be too low or too high. • Hopper floor not sealed inside against the rear crossmember. Unit may be picking up but throwing it through gap onto the ground. • Louvers on top of door and hopper may be clogged, blocking air flow. • Also check for build up on bottom of oil tank above front reel. 	<ul style="list-style-type: none"> • Replace missing or broken fingers. • See SWEEPER REELS TIMING CHAIN ADJUSTMENTS • Replace chain. • Replace key. • Replace belt/ adjust tension. • Replace key. • Adjust height. See SWEEPER REELS LEVELING AND HEIGHT ADJ. in manual. • Bend hopper floor back to seal hopper. • Clean out any blocked louvers. • Clean off any buildup on oil tank.
<p>EXCESSIVE VIBRATION</p>	<ul style="list-style-type: none"> • Check bearings on reel shaft. If they are excessively hot, they probably are damaged. • Foreign materials wrapped around reel shaft. • Reels could be bent. Should be within .015 for straightness. 	<ul style="list-style-type: none"> • Replace any damaged bearings. • Clean off any foreign objects. • Check shaft with dial calipers.

STORAGE

1. Thoroughly clean the sweeper so it is free of dirt, leaves and debris.
2. Inflate tires to 22 PSI.
3. Check all fasteners. Tighten as necessary.
4. Grease or oil all grease fittings and bearings. Wipe off excess lubricant.
5. Drain and replace hydraulic fluid and filter. Inspect all hydraulic lined and fittings. Replace if necessary. Refer to the Maintenance section.
6. Check the tension and condition of the drive chain. Adjust the tension if necessary and lightly coat the chain with grease.
7. Check the tension and condition of the drive belt.
8. Check the condition of the rubber fingers. Replace any broken or missing fingers.
9. Service the battery and cables as follows:
 - A. Remove the battery terminals from the battery posts.
 - B. Clean the battery, terminals and posts with a wire brush and baking soda solution.
 - C. Coat the cable terminals and battery posts with Grafo 112X skin over grease (Toro Part Number 505-46), or petroleum jelly to prevent corrosion.
 - D. Slowly recharge the battery every 60 days for 24 hours to prevent lead sulfating of the battery.

ENGINE

1. Drain the engine oil from the oil pan and replace drain plug.
2. Remove and discard the oil filter. Install a new oil filter.
3. Refill oil pan with 2-1/2 quarts of SF - CC, 10W30 motor oil.
4. Start the engine and run at idle speed for approximately two minutes.
5. Stop the engine.
6. Thoroughly drain all fuel from the fuel tank, lines and the fuel pump filter.
7. Flush the fuel tank with fresh clean gasoline.
8. Re-secure all fuel system fittings.

IDENTIFICATION AND ORDERING

MODEL AND SERIAL NUMBER

The TURF SWEEPER 5400HL has two identification numbers: a model and serial number. The two numbers are stamped on a plate which is riveted to Seat Bracket by the throttle control. In any correspondence concerning the Turf Sweeper 5400HL, supply model and serial numbers to be sure that the correct information and replacement parts are obtained.

To order replacement parts from an authorized TORO Distributor, supply the following information.

1. Model and serial numbers of the machine.
2. Part number, description and quantity of parts desired.

Note: Do not order by reference number if a parts catalog is being used; use the part number.

SWEEPER 5400HL Maintenance Schedule

Minimum Recommended Maintenance Intervals:

Maintenance Procedure	Maintenance Interval & Service			
	100 Hrs	200 Hrs	400 Hrs	
Check battery fluid level 50 Hrs Check battery cable connections + Change engine oil Adjust parking brake shoes A Level Service Inspect rubber fingers				
Lube all grease fittings Grease bearings Lube steering gears + Torque wheel motor nuts Inspect traction spring and linkage movement Lube wheels and wheel bearings Inspect all hydraulic hoses Replace engine gas filter B Level Service Check condition of flex coupling				
Check belt tension and condition Check chain tension and condition Inspect sprockets and idler spring Inspect rubber seals on hopper Check steering gear movement C Level Service Inspect reel pivot bolt and spacer				
= Check engine RPM (idle and full throttle) Change Air Filter D Level Service = Torque Head and Adjust Valves				
+ Initial break in at 10 hours. = Initial break in at 50 hours.				
Hydraulic Tank - Drain/Flush Annual Recommendations Replace moving hoses Fuel Tank - Drain/Flush				

SWEEPER 5400HL Maintenance Schedule

Unit Designation _____

Daily Maintenance: (duplicate this page for routine use)

TORO ID# _____

Maintenance Check Item	Daily Maintenance Check for Week Of						
	MON	TUES	WED	THUR	FRI	SAT	SUN
✓ Engine Oil Level							
✓ Air Cleaner Condition							
✓ Unusual Operating Noises							
✓ Hydraulic System Oil Level							
✓ Hydraulic Filter Gage							
✓ Hydraulic Hoses for Damage							
✓ Tire Pressure							
✓ Inspect Rubber Fingers							
✓ Unusual Engine Noises							
✓ Brake Operation							

Notation for areas of concern:

Inspection performed by: _____

Item	Date	Information
1		
2		
3		
4		
5		
6		
7		
8		
9		
10		

The Toro Commercial Products Two Year Limited Warranty

The Toro Company warrants your 1996 or newer Toro Commercial Product ("Product") purchased after January 1, 1997, to be free from defects in materials or workmanship for the period of time listed below. Where a warrantable condition exists, Toro will repair the Product at no cost to you including diagnosis, labor, parts, and transportation. This warranty begins on the date the Product is delivered to the original retail purchaser.

Warranty Duration: Two years or 1500 operational hours*, whichever occurs first.

*Product equipped with hour meter

Owner Responsibilities:

As the Product owner, you are responsible for required maintenance and adjustments stated in your Owner's Manual. Failure to perform required maintenance and adjustments can be grounds for disallowing a warranty claim.

Instructions for Obtaining Warranty Service:

You are responsible for notifying the Commercial Products Distributor or Authorized Commercial Products Dealer from whom you purchased the Product as soon as you believe a warrantable condition exists.

If you need help locating a Commercial Products Distributor or Authorized Dealer, or if you have questions regarding your warranty rights or responsibilities, you may contact us at:

Toro Commercial Products Service Department
8111 Lyndale Avenue South
Minneapolis, MN, 55420-1196
Telephone: (612) 888-8801
Facsimile: (612) 887-8258
E-Mail: Commercial.Service@Toro.Com

Maintenance Parts:

Parts scheduled for replacement as required maintenance ("Maintenance Parts"), are warranted for the period of time up to the scheduled replacement time for that part.

Items/Conditions Not Covered:

Not all product failures or malfunctions that occur during the warranty period are defects in materials or workmanship. The items / conditions listed below are not covered by this warranty:

- Product failures which result from the use of non-Toro replacement parts, or from installation and use of add-on, modified, or unapproved accessories are not covered.
- Product failures which result from failure to perform required maintenance and/or adjustments are not covered.
- Product failures which result from operating the Product in an abusive, negligent or reckless manner are not covered.

- This warranty does not apply to parts subject to consumption through use unless found to be defective. Examples of parts which are consumed, or used up, during normal Product operation include, but are not limited to, blades, reels, bedknives, tines, spark plugs, castor wheels, tires, filters, belts, etc.
- This warranty does not apply to failures caused by outside influence. Items considered to be outside influence include, but are not limited to, weather, storage practices, contamination, use of unapproved coolants, lubricants, additives, or chemicals, etc.
- This warranty does not apply to normal "wear and tear" items. Normal "Wear and Tear" includes, but is not limited to, damage to seats due to wear or abrasion, worn painted surfaces, scratched decals or windows, etc.

Other Legal Disclaimers:

The above remedy of product defects through repair by an authorized distributor or dealer is the purchaser's sole remedy for any defect. This warranty gives you specific legal rights, and you may also have other rights which vary from state to state.

Except for the Emissions warranty referenced below, if applicable, there is no other express warranty. All implied warranties of merchantability and fitness for use are limited to the duration of the express warranty.

Some states do not allow limitations on how long an implied warranty lasts, so the above limitation may not apply to you.

The Toro Company is not liable for indirect, incidental or consequential damages in connection with the use of the Product, including any cost or expense of providing substitute Product or service during periods of malfunction or non-use.

Some states do not allow the exclusion of incidental or consequential damages, so the above exclusion may not apply to you.

Note to California residents: The Emissions Control System on your Product may be covered by a separate warranty meeting requirements established by the U.S. Environmental Protection Agency (EPA), or the California Air Resources Board (CARB). The hour limitations set forth above do not apply to the Emissions Control System Warranty. Refer to the California Emission Control Warranty Statement printed in your Owner's Manual or contained in the engine manufacturer's documentation for details.