



Count on it.

Operator's Manual

Workman® GTX Electric Utility Vehicle

Model No. 07041—Serial No. 40000000 and Up

Model No. 07043—Serial No. 40000000 and Up

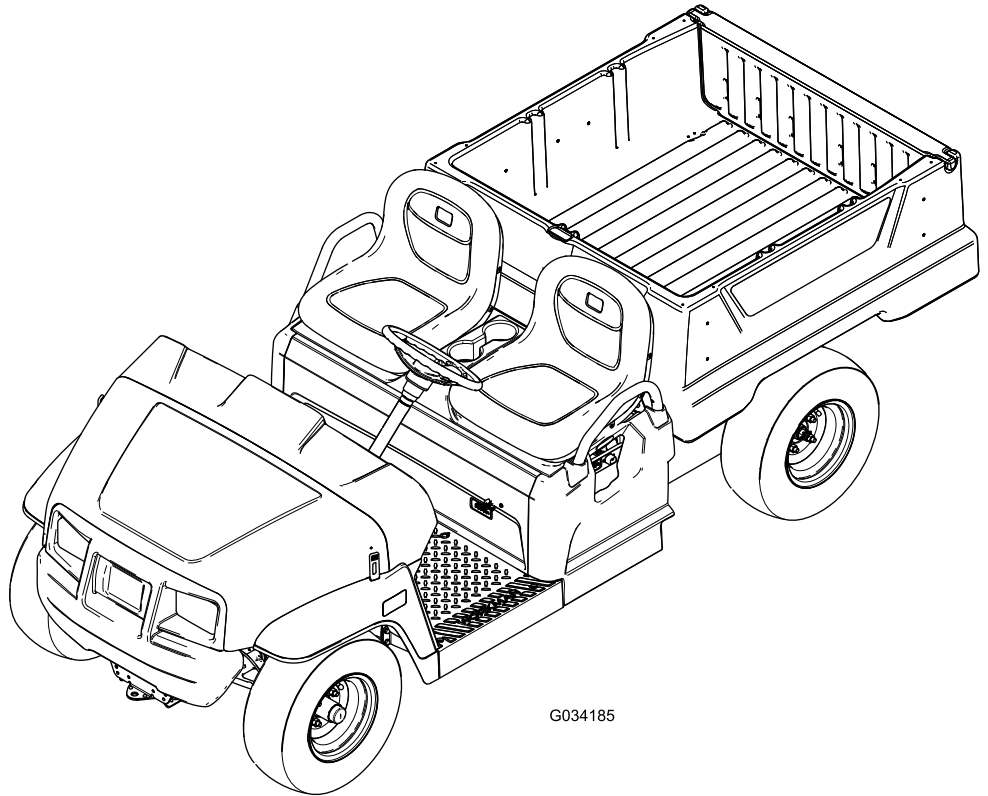

G034185



This product complies with all relevant European directives; for details, please see the separate product specific Declaration of Conformity (DOC) sheet.

⚠ WARNING

**CALIFORNIA
Proposition 65 Warning**

The power cord on this product contains lead, a chemical known to the State of California to cause birth defects or other reproductive harm. Wash hands after handling.

Battery posts, terminals, and related accessories contain lead and lead compounds, chemicals known to the State of California to cause cancer and reproductive harm. Wash hands after handling.

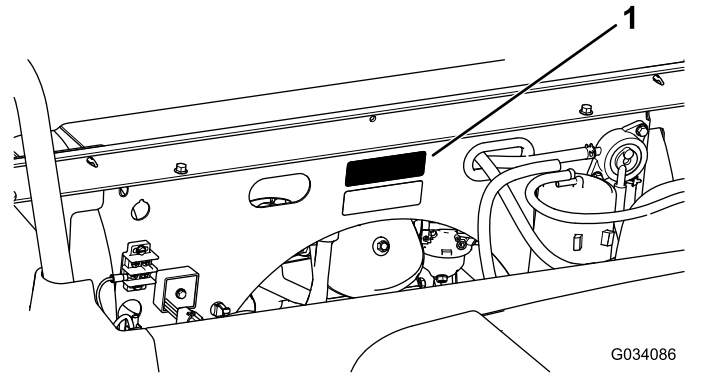

G034086
g034086

Figure 1
Bottom of Seat Assembly Shown

1. Model and serial-number location

Model No. _____
Serial No. _____

This manual identifies potential hazards and has safety messages identified by the safety-alert symbol (Figure 2), which signals a hazard that may cause serious injury or death if you do not follow the recommended precautions.



g000502

Figure 2

1. Safety-alert symbol

Introduction

Read this information carefully to learn how to operate and maintain your product properly and to avoid injury and product damage. You are responsible for operating the product properly and safely.

You may contact Toro directly at www.Toro.com for product and accessory information, help finding a dealer, or to register your product.

Whenever you need service, genuine Toro parts, or additional information, contact an Authorized Service Dealer or Toro Customer Service and have the model and serial numbers of your product ready. Figure 1 identifies the location of the model and serial numbers on the product. Write the numbers in the space provided.

This manual uses 2 words to highlight information. **Important** calls attention to special mechanical information and **Note** emphasizes general information worthy of special attention.

Contents

Safety	4	Maintaining the Tires	41
Safe Operating Practices	4	Inspecting the Steering and Suspension Components	41
Supervisor's Responsibilities	4	Adjusting the Front Wheel Toe-in	42
Before Operating	4	Changing the Transaxle Fluid	43
Operation.....	4	Brake Maintenance	43
Handling and Servicing Batteries	8	Checking the Parking Brake	43
Maintenance.....	8	Adjusting the Parking Brake.....	43
Safety and Instructional Decals	9	Checking the Brake-Fluid Level	44
Setup	12	Inspecting the Brakes	44
1 Installing the Steering Wheel (International Models Only).....	12	Replacing the Service and Parking-Brake Pads.....	44
2 Checking the Fluid Levels and Tire Pressure	12	Changing the Brake Fluid	45
3 Reading the Manual and Viewing the Safety Training Material	13	Chassis Maintenance.....	45
Product Overview	14	Adjusting the Cargo-Box Latches.....	45
Controls	15	Cleaning	46
Specifications	18	Washing the Machine	46
Attachments/Accessories	18	Storage	47
Operation	19	Battery Storage	47
Think Safety First.....	19	Troubleshooting	48
Operating the Cargo Box	19		
Using the Rear Cargo Box Accessory Mount.....	21		
Performing Pre-Starting Checks	22		
Checking the Tire Pressure.....	22		
Understanding and Using the Battery System.....	22		
Stopping the Machine	24		
Parking the Machine	24		
Breaking in a New Machine	24		
Loading the Cargo Box	25		
Transporting the Machine	25		
Towing the Machine	26		
Towing a Trailer	26		
Maintenance	27		
Recommended Maintenance Schedule(s)	27		
Daily Maintenance Checklist.....	28		
Pre-Maintenance Procedures	29		
Maintaining the Machine under Special Operating Conditions	29		
Preparing to Maintain the Machine.....	29		
Lifting the Machine	29		
Accessing the Hood.....	30		
Raising and Lowering the Seat Assembly	30		
Removing the Seat Assembly	31		
Installing the Seat Assembly	31		
Lubrication	31		
Greasing the Machine.....	31		
Greasing the Front Wheel Bearings	32		
Electrical System Maintenance	35		
Maintaining the Batteries	35		
Replacing the Fuses	39		
Maintaining the Headlights	39		
Drive System Maintenance	41		

Safety

Improper use or maintenance by the operator or owner can result in injury. To reduce the potential for injury, comply with these safety instructions and always pay attention to the safety-alert symbol, which means **Caution**, **Warning**, or **Danger**—personal safety instruction. Failure to comply with the instruction may result in personal injury or death.

The machine meets the requirements of SAE J2258.

Important: For CE required regulatory data, refer to the Declaration of Conformity supplied with the machine.

Safe Operating Practices

Important: This machine is designed primarily as an off-road machine and is not intended for extensive use on public roads.

When using the machine on public roads, follow all traffic regulations and use any additional accessories that may be required by law, such as lights, turn signals, slow-moving vehicle (SMV) signs, and others as required.

This machine was designed and tested to offer safe service when operated and maintained properly. Although hazard control and accident prevention are dependent upon the design and configuration of the machine, these factors are also dependent upon the awareness, concern, and proper training of the operator, maintenance, and storage of the machine. Improper use or maintenance of the machine can result in injury or death.

This machine has a different feel than what drivers experience with passenger cars or trucks. So take time to become familiar with your machine.

Not all the attachments that adapt to the machine are covered in this manual. See the specific *Operator's Manual* provided with each attachment for additional safety instructions.

To reduce the potential for injury or death, comply with the following safety instructions:

Supervisor's Responsibilities

Make sure that the operators are thoroughly trained and familiar with the *Operator's Manual* and all labels on the machine.

Before Operating

- This machine is designed to carry **only you**, the operator, and **1 passenger** in the seat provided by the manufacturer. **Never** carry any other passengers on the machine.
- Become familiar with the controls and know how to stop the machine quickly.
- **Never** operate the machine when tired, ill, or under the influence of drugs or alcohol.
- Wear substantial, slip-resistant shoes. Do not wear loose-fitting clothing, tie back long hair, and do not wear jewelry.
- Wearing safety glasses, safety shoes, and long pants are required by some local regulations.
- **Never** allow children to operate the machine. **Never** allow adults to operate it without proper instructions. Only trained and authorized persons should operate this machine.
- Always be aware of where bystanders are.
- Keep all shields, safety devices and decals in place. If a shield, safety device or decal is malfunctioning, illegible, or damaged, repair or replace it before operating the machine.
- Avoid driving when it is dark, especially in unfamiliar areas. If you must drive when it is dark, use the headlights.
- Before operating the machine, always check all parts of the machine and any attachments. If something is wrong, **stop using machine**. Make sure that the problem is corrected before machine or attachment is operated again.
- Operate the machine only outdoors or in a well-ventilated area.

Operation

- You and the passenger should remain seated whenever the machine is in motion. You should keep both hands on the steering wheel, whenever possible, and the passenger should use the handholds provided. Keep your arms and legs within the machine body at all times.
- Drive slower and turn less sharply when you are carrying a passenger. Remember that your passenger may not be expecting you to brake or turn and may not be ready. Never carry passengers in the box or on attachments.
- Never overload the machine. The name plate (located under the seat assembly on the rear panel) shows the load limits for the machine. Never overfill attachments or exceed the maximum gross vehicle weight (GVW).
- Failure to operate machine safely may result in an accident, tip over of the machine, and serious

injury or death. Drive carefully. To prevent tipping or loss of control, take the following precautions:

- Use extreme caution, reduce speed, and maintain a safe distance around sand traps, ditches, creeks, ramps, any unfamiliar areas, or other hazards.
- Watch for holes or other hidden hazards.
- Use caution when operating the machine on a slope. Normally, travel straight up and down slopes. Reduce speed when making sharp turns or when turning on hillsides. Avoid turning on hillsides whenever possible.
- Use extra caution when operating the machine on wet surfaces, at higher speeds, or with a full load. Stopping time increases with a full load.
- Avoid sudden stops and starts.
- Do not attempt sharp turns or abrupt maneuvers or other unsafe driving actions that may cause a loss of control of the machine.
- When dumping, do not let anyone stand behind machine and do not dump the load on anyone's feet.
- Keep all bystanders away. Before backing up, look to the rear and ensure that no one is behind the machine. Back up slowly.
- Watch out for traffic when near or crossing roads. Always yield the right of way to pedestrians and other machines. Always signal your turns or stop early enough so other persons know what you plan to do. Obey all traffic rules and regulations.
- Never operate the machine in or near an area where there is dust or fumes in the air which are explosive. The electrical and exhaust systems of the machine can produce sparks capable of igniting explosive materials.
- Always watch out for and avoid low overhangs such as tree limbs, door jambs, over head walkways, etc. Make sure there is enough room over head to easily clear the machine and your head.
- If you are ever unsure about the safe operation of the machine, **stop your work** and ask your supervisor.
- Before getting off the seat, do the following:
 - Stop the movement of the machine.
 - Lower the bed.
 - Engage the parking brake.
 - Remove the key.
- If the machine ever vibrates abnormally, stop the machine immediately, and wait for all motion to

stop and inspect for damage. Repair all damage before resuming operation.

- Lightning can cause severe injury or death. If lightning is seen or thunder is heard in the area, do not operate the machine; seek shelter.

Special Operation with the Multi-Passenger Kit Installed

- With the multi-passenger kit installed, you must account for the extra passengers contributing to the overall gross vehicle weight (GVW) of the machine.
- If you have a load in the cargo box, ensure that you do not exceed the capacity of the machine by having too many passengers.
- Passengers should sit in the designated seating positions only. Do not allow passengers to sit in the cargo box.
- The operator and passengers should remain seated whenever the machine is in motion.
- Additional machine length results in a larger turn radius, so allow more space to maneuver.

Braking

- Slow down the machine before you approach an obstacle. This gives you extra time to stop or turn away. Hitting an obstacle can injure you and your passenger. In addition, it can damage the machine and its contents.
- Gross vehicle weight (GVW) has a major impact on your ability to stop and/or turn. Heavy loads and attachments make the machine harder to stop or turn. The heavier the load, the longer it takes to stop.
- Decrease the speed of the machine if the cargo box has been removed and there is no attachment installed on the machine. The braking characteristics change and fast stops may cause the rear wheels to lock up, which affects the control of the machine.
- Turf and pavement are much more slippery when they are wet. It can take 2 to 4 times longer to stop the machine on wet surfaces as on dry surfaces. If you drive through deep-standing water and get the brakes wet, they will not work well until they are dry. After driving through water, you should test the brakes to make sure that they work properly. If they do not, drive slowly on level ground while putting light pressure on the brake pedal. This dries out the brakes.

Operating on Hills

⚠ WARNING

Operating the machine on a hill may cause tipping or rolling of the machine, or the batteries may run low and you could lose headway on the hill. This could result in personal injury.

- **Do not operate the machine on excessively steep slopes.**
- **Do not accelerate quickly or slam the brakes when backing down a hill, especially with a load.**
- **If the batteries run low or you begin to lose headway while climbing a hill, gradually apply the brakes and slowly back straight down the hill.**
- **Operate the machine slowly on a hill and use caution.**
- **Avoid turning on a hill.**
- **Reduce your load and the speed of the machine.**
- **Avoid stopping on hills, especially with a load.**

Note: A 2-post ROPS (Rollover-Protection System) is available for this machine as an accessory. A ROPS is recommended if you will be working next to drop-offs, near water, in rough terrain, or on hills/banks, which could result in a rollover. Contact an Authorized Toro Service Distributor for more details.

Take these precautions when operating the machine on a hill:

- Slow the machine down before starting up or down a hill.
- If the batteries run low or you begin to lose momentum while climbing a hill, gradually apply the brakes and slowly back the machine straight down the hill.
- Turning while traveling up or down hills can be dangerous. If you have to turn while on a hill, do it slowly and cautiously. Never make sharp or fast turns.
- Heavy loads affect stability. Reduce the weight of the load and your ground speed when operating on hills or if the load has a high center of gravity. Secure the load to the cargo box of the machine to prevent the load from shifting. Take extra care when hauling loads that shift easily (liquid, rock, sand, etc.).
- Avoid stopping on hills, especially with a load. Stopping while going down a hill takes longer than stopping on level ground. If you must stop the

machine, avoid sudden speed changes, which may initiate tipping or rolling of the machine. Do not slam on the brakes when rolling backward, as this may cause the machine to overturn.

Operating on Rough Terrain

Reduce the ground speed of the machine and load carried in the machine when operating on rough terrain, uneven ground, and near curbs, holes, and other sudden changes in terrain. Loads may shift, causing the machine to become unstable.

⚠ WARNING

Sudden changes in terrain may cause abrupt steering wheel movement, possibly resulting in hand and arm injuries.

- **Reduce your speed when operating on rough terrain and near curbs.**
- **Grip the steering wheel loosely around the perimeter, keeping thumbs up and out of the way of the steering wheel spokes.**

Loading and Dumping

- Do not exceed the rated weight capacity of the machine when operating it with a load in the cargo box, when towing a trailer, or both; refer to [Specifications \(page 18\)](#).
- Use caution when operating the machine on a hillside or on rough terrain, particularly with a load in the cargo box or when towing a trailer or both.
- Be aware that the stability and control of the machine are reduced when the load in the cargo box is poorly distributed.
- Carrying oversized loads in the cargo box changes the stability of the machine.
- The steering, braking, and stability of the machine are affected when carrying a load where the weight of the material cannot be bound to the machine, such as the liquid in a large tank.

⚠ WARNING

The weight of the box may be heavy. Hands or other body parts could be crushed.

- **Keep your hands and other body parts away when lowering the box.**
- **Do not dump materials on bystanders.**
- Never dump a loaded cargo box while the machine is sideways on a hill. The change in weight distribution may cause the machine to overturn.

- When operating with a heavy load in the cargo box, reduce your speed and allow for sufficient braking distance. Do not suddenly apply the brakes. Use extra caution on slopes.
- Be aware that heavy loads increase your stopping distance and reduce your ability to turn quickly without tipping over.
- The rear cargo space is intended for load carrying purposes only, not for passengers.

Handling and Servicing Batteries

- To reduce the potential for fire, keep the batteries and motor area free of excessive grease, grass, leaves, and accumulation of dirt.
- Always disconnect the battery cables before servicing any electrical components; refer to [Disconnecting the Batteries \(page 37\)](#).

Note: Disconnecting all of the battery cables isolates power from the electrical system.

- Battery electrolyte contains sulfuric acid. Sulfuric acid produces hydrogen gas, which, in the right proportions, is explosive.
 - Always service, store, and charge the machine in a well-ventilated area.
 - Keep sparks and open flames away from the batteries.
 - Do not smoke near the batteries.
 - Never use an open flame to check the level or leakage of battery electrolyte.
- Use caution when handling and working around electrolyte. The sulfuric acid in electrolyte can burn skin and damage clothing. Furthermore, it can be emitted as a gas that can damage your lungs.
 - Wear proper eye, hand, and face protection.
 - Do not lean over the batteries at any time.
 - Avoid breathing in battery fumes.
 - Fill the batteries where clean water is always available for flushing the skin.
 - If you get electrolyte on your skin or eyes, flush the affected area for 20 minutes with clean water. Remove acid-soaked clothing. Seek medical attention immediately.
 - Keep children and pets away from the batteries and electrolyte.
- Electrolyte is very poisonous.
 - Do not drink the electrolyte.
 - If electrolyte has been swallowed, and the person is conscious, have them drink large quantities of water immediately to dilute the electrolyte.
 - Do not attempt to make them vomit.
 - Call Poison Control and get medical attention immediately.
- When not filling the batteries, keep the battery vent caps tight on the batteries. Never operate the machine if any of the vent caps are missing or damaged.
- When removing or installing the batteries, do not allow the battery terminals to touch any metal parts of the machine.

- Do not allow metal tools to short between the battery terminals and metal parts of the machine. Remove all jewelry and watches before servicing the batteries.
- Do not check a battery charge by placing a metal object across the posts. This causes sparks, which can cause an explosion.
- Always keep the battery retainers in place to protect and secure the batteries.
- Read and understand the charging instructions before charging the batteries; refer to [Charging the Batteries \(page 35\)](#). Also, take the following precautions and actions when charging the batteries:
 - Turn the machine key switch to OFF before connecting the charger to a power source.
 - Use only the battery charger supplied with the machine to charge the batteries.
 - Do not charge a damaged or frozen battery.
 - Always unplug the AC power cord from the power outlet before unplugging it from the machine charging receptacle to avoid sparks.
 - If a battery gets hot while charging, begins emitting large amounts of gases, or spews electrolyte, immediately disconnect the charger power cord from the power outlet. Have the machine serviced by an Authorized Service Dealer before using it again.

Maintenance

- Before servicing or making adjustments to the machine, park the machine on a level surface, engage the parking brake, shut off the machine, and remove the key to prevent accidental starting of the machine.
- Never work under a raised bed without ensuring that the prop rod is fully seated in the detent slot.
- To make sure that the entire machine is in good condition, keep all nuts, bolts, and screws properly tightened.
- If the machine must be running to perform a maintenance adjustment, keep hands, feet, clothing, and any parts of the body away from the batteries and any moving parts. Keep everyone away.
- If major repairs are ever needed or assistance is required, contact an Authorized Toro Distributor.
- To ensure optimum performance and safety, always purchase genuine Toro replacement parts and accessories. Replacement parts and accessories made by other manufacturers could be dangerous. Altering this machine in any manner may affect the operation of the machine, performance, durability or its use may result in

injury or death. Such use could void the product warranty of The Toro® Company.

Safety and Instructional Decals



Safety decals and instructions are easily visible to the operator and are located near any area of potential danger. Replace any decal that is damaged or missing.



99-7345

decal99-7345

1. Warning—read the *Operator's Manual*.
2. Hot surface/burn hazard—stay a safe distance away from hot surfaces.
3. Entanglement hazard, belt—stay away from moving parts; keep all guards in place.
4. Crushing hazard, cargo box—use the prop rod to support the cargo bed

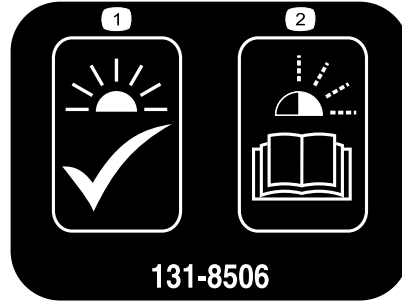

131-8506

decal131-8506

131-8506

1. Solid light—unit is prepared for operation.
2. Flashing light—refer to the charger manual for the fault codes.

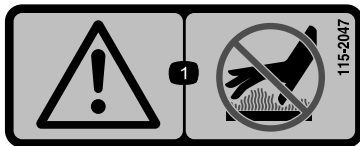

115-2047

decal115-2047

1. Warning—do not touch the hot surface.

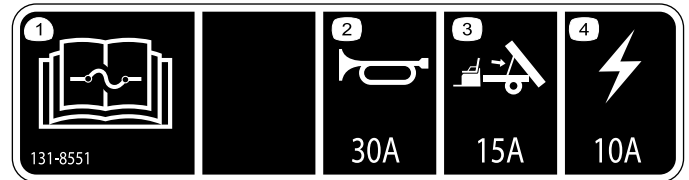

131-8551

decal131-8551

131-8551

1. Read the *Operator's Manual* for fuse information.
2. Horn (30 A)
3. Optional lift kit (15 A)
4. Main power (10 A)

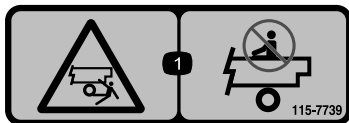

115-7739

decal115-7739

1. Falling, crushing hazard, bystanders—no riders on machine.

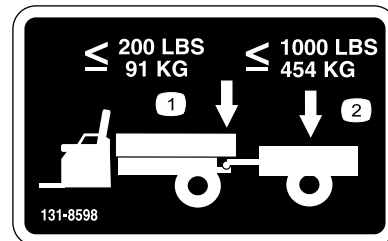

131-8598

decal131-8598

1. Maximum bed weight 91 kg (200 lb)
2. Maximum trailer weight 454 kg (1,000 lb)



120-9570

decal120-9570

1. Warning—stay away from moving parts, keep all guards and shields in place.

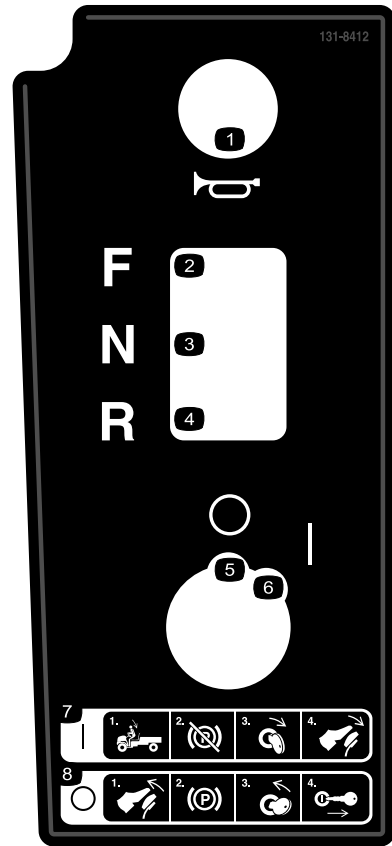

131-8412

decal131-8412

- | | |
|------------|---|
| 1. Horn | 5. Off |
| 2. Forward | 6. On |
| 3. Neutral | 7. Turning on—1) Sit in the driver's seat; 2) Disengage the parking brake; 3) Turn the key switch to the start position; 4) Push down on the pedal. |
| 4. Reverse | 8. Turning off—1) Release the pedal; 2) Engage the parking brake; 3) Turn the key switch to the stop position; 4) Remove the key from the key switch. |

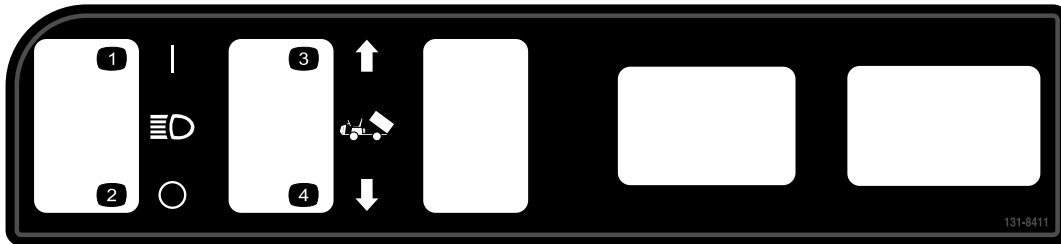

131-8411

decal131-8411

- | | |
|------------------|-------------------|
| 1. Headlight—on | 3. Raise the bed. |
| 2. Headlight—off | 4. Lower the bed. |

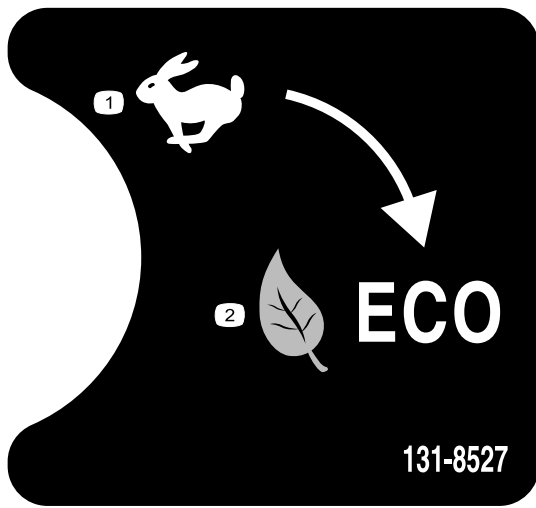

decal131-8527

131-8527

1. Performance mode
2. Eco mode

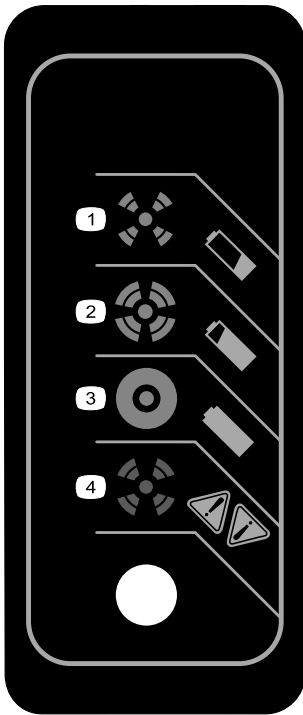

decal131-8495

131-8495

1. The battery is empty.
2. The battery is almost charged.
3. The battery is charged.
4. Charger fault; refer to the charger manual for the fault codes.



decal131-8414

131-8414

1. Warning—read the *Operator's Manual*.
2. Warning—receive proper training before operating the machine.
3. Tipping hazard—drive slowly across or up slopes; take turns slowly; do not exceed speeds of 25 kph (16 mph); drive slowly when hauling cargo; drive slowly on uneven terrain.
4. Falling hazard; severing hazard of limbs—do not carry passengers in the bed; do not carry extra passengers in between the seats; do not put your arms or legs outside of the machine while operating.

Setup

Loose Parts

Use the chart below to verify that all parts have been shipped.

Procedure	Description	Qty.	Use
1	Steering wheel	1	Install the steering wheel (International models only).
	Steering wheel cover	1	
	Washer (1/2 inch)	1	
	Dust cover	1	
2	No parts required	–	Check the fluid levels and tire pressure.
3	Operator's Manual	1	Read the Operator's Manual and view the training material before operating the machine.
	Safety training material	1	
	Registration card	1	
	Predelivery Inspection Form	1	
	Certificate of Quality	1	
	Key	2	
Charger cord (Domestic Models only)	1		

Note: Determine the left and right sides of the machine from the normal operating position.

1

Installing the Steering Wheel (International Models Only)

Parts needed for this procedure:

1	Steering wheel
1	Steering wheel cover
1	Washer (1/2 inch)
1	Dust cover

Procedure

- If the cover is installed, remove it from the hub of the steering wheel (Figure 3).
- Remove the locknut (1/2 inch) from the steering shaft (Figure 3).
- Slide the steering wheel, dust cover, and washer (1/2 inch) onto the steering shaft (Figure 3).

Note: With the front wheels straight, orient the steering wheel so that the smaller spoke on the steering wheel is vertical.

- Secure the steering wheel to the shaft with the locknut (1/2 inch) and tighten it to 18 to 30 N·m (13 to 22 ft-lb).
- Install the cover on the steering wheel (Figure 3).

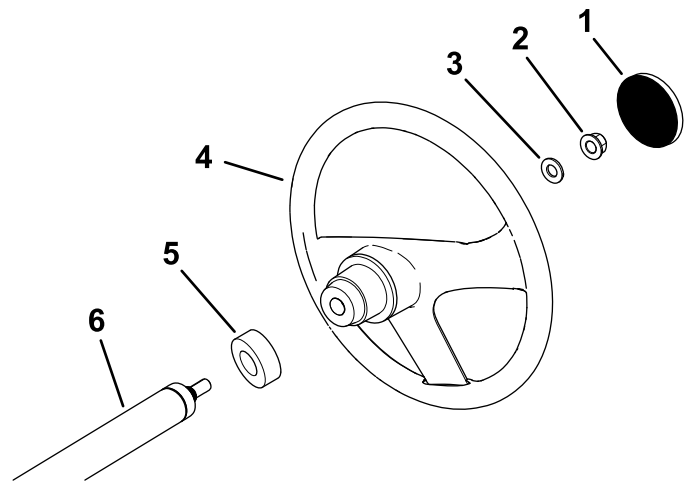

Figure 3

- | | |
|-------------------------|-------------------|
| 1. Steering wheel cover | 4. Steering wheel |
| 2. Locknut (1/2 inch) | 5. Dust cover |
| 3. Washer (1/2 inch) | 6. Steering shaft |

g198932

2

Checking the Fluid Levels and Tire Pressure

No Parts Required

Procedure

1. Check the water level in the batteries before operating the machine; refer to [Checking the Water Level of the Batteries \(page 36\)](#).
2. Ensure that the batteries are charged; refer to [Charging the Batteries \(page 35\)](#).
3. Check the brake-fluid level before the machine is first operated; refer to [Checking the Brake-Fluid Level \(page 44\)](#).
4. Check the air pressure in the tires; refer to [Checking the Tire Pressure \(page 22\)](#).

3

Reading the Manual and Viewing the Safety Training Material

Parts needed for this procedure:

1	<i>Operator's Manual</i>
1	Safety training material
1	Registration card
1	<i>Predelivery Inspection Form</i>
1	Certificate of Quality
2	Key
1	Charger cord (Domestic Models only)

Procedure

- Read the *Operator's Manual*.
- View the safety training material.
- Fill out the registration card.
- Complete the *Predelivery Inspection Form*.
- Review the *Certificate of Quality*.

Product Overview

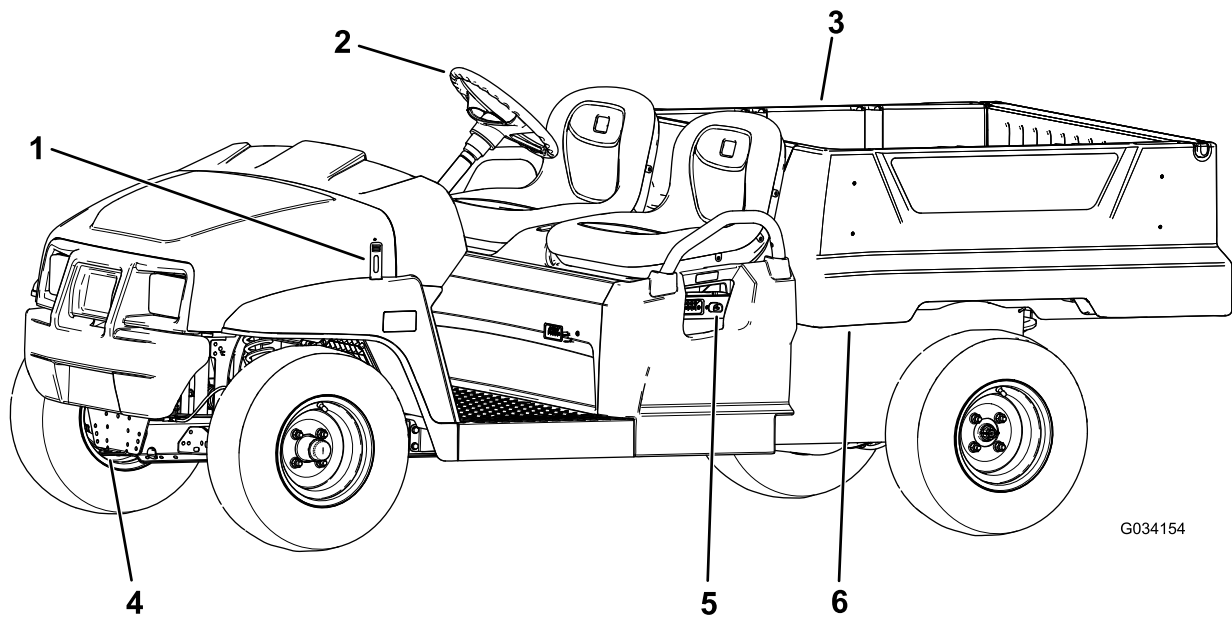

Figure 4

g034154

- | | | |
|-------------------|------------------|--------------------|
| 1. Hood latch | 3. Cargo box | 5. Battery charger |
| 2. Steering wheel | 4. Towing tongue | 6. Cargo-box lever |

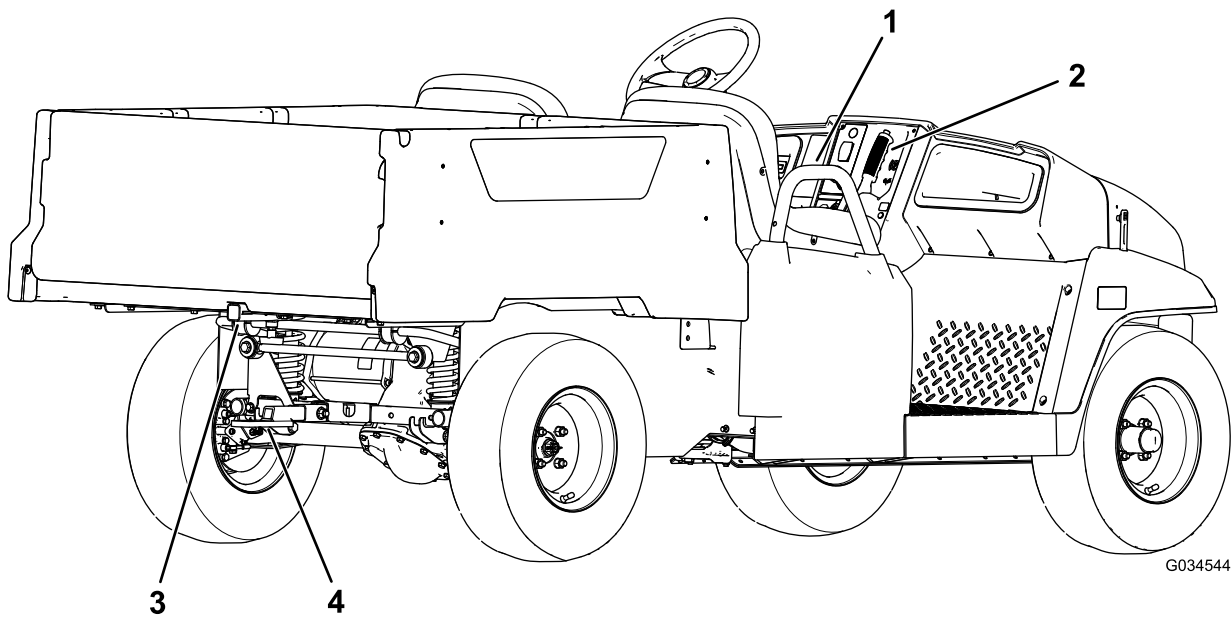

Figure 5

g034544

- | | |
|------------------------|-----------------------------------|
| 1. Passenger handhold | 3. Rear cargo-box-accessory mount |
| 2. Parking-brake lever | 4. Trailer hitch |

Controls

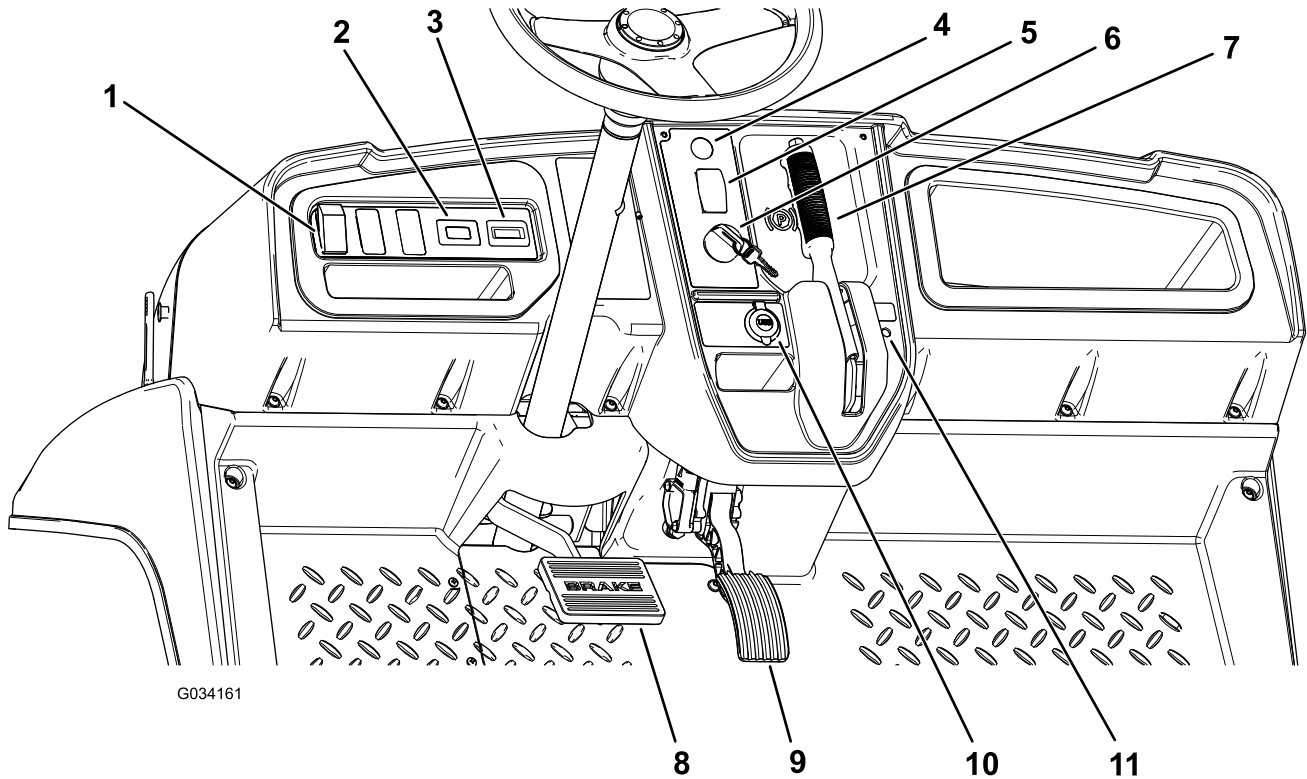

Figure 6

1. Light switch
2. Hour meter
3. Battery-discharge indicator
4. Horn button (International models only)
5. Gear-shift selector
6. Key switch
7. Parking-brake lever
8. Brake pedal
9. Accelerator pedal
10. USB power point
11. Status-indicator light

Accelerator Pedal

Use the accelerator pedal (Figure 6) to vary ground speed of the machine. Pressing down the accelerator pedal starts the machine. Pressing the pedal farther increases ground speed. Releasing the pedal slows the machine, and the machine shuts off.

The maximum forward speed in performance mode is 26 km/h (16 mph) as shown in Figure 9.

The maximum forward speed in economy mode is 19 km/h (12 mph) as shown in Figure 9.

Brake Pedal

Use the brake pedal to stop or slow the machine (Figure 6).

⚠ CAUTION

Operating a machine with worn or incorrectly adjusted brakes can may result in personal injury.

If brake pedal travels to within 25 mm (1 inch) of the machine floorboard, adjust or repair the brakes.

Parking-Brake Lever

The parking-brake lever is located on the control panel (Figure 6).

Whenever you shut off the machine, engage the parking brake to prevent the machine from accidental moving. If the machine is parked on a steep grade, make sure that you engage the parking brake.

To engage the parking brake, pull the parking-brake lever toward you (Figure 7).

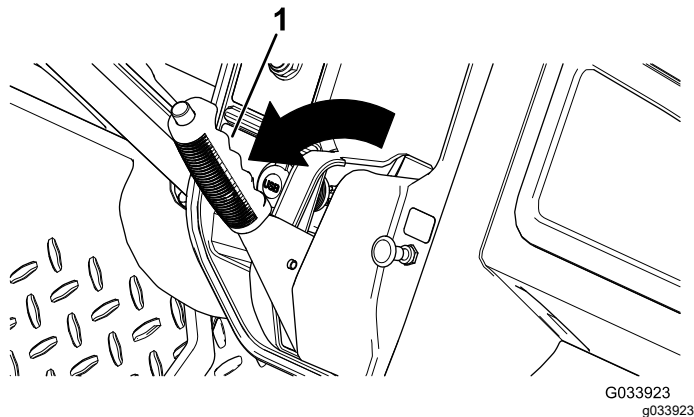

Figure 7

1. Parking-brake lever

To disengage the parking brake, push down the button on top of the parking brake lever, pull the parking-brake lever toward you to release pressure, and then push the parking-brake lever forward (Figure 8).

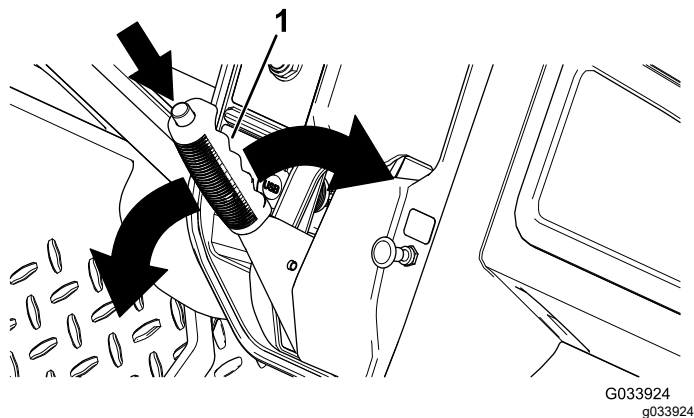

Figure 8

1. Parking-brake lever and button

Direction Selector

The direction selector is located to the left of the parking-brake lever. The direction selector has 3 positions: FORWARD, REVERSE, and NEUTRAL (Figure 6).

Note: The machine can be on in any of the 3 positions, but only moves in the FORWARD and REVERSE positions.

Important: Always stop the machine before changing direction.

Horn Button

International Models Only

The horn button is located on the control panel (Figure 6). Press the horn button to sound the horn.

Light Switch

The light switch is located to the left of the steering column (Figure 6). Use the light switch to illuminate the headlights. Push the light switch upward to turn on the headlights or push downward to turn off the lights.

Battery-Discharge Indicator

The battery-discharge indicator is located to the left of the steering column (Figure 6). The battery-discharge indicator indicates the remaining charge in the batteries. When the machine batteries are fully charged, ten indicator bars extend from the 0 to the 1 position. As the charge is used, the indicator bars disappear starting at the right side of the meter. For detailed information on the battery meter, refer to [Understanding and Using the Battery System \(page 22\)](#).

Hour Meter

The hour meter is located to the right of the light switch (Figure 6). Use the hour meter to find out the total number of operating hours. The hour meter starts to function whenever you turn the key switch to the ON position or if the machine is running.

Note: When the machine is running, the hour meter blinks continuously, recording usage.

USB Power Point

The USB power point is located to the left of the parking-brake lever (Figure 6). Use the power point to power mobile devices.

Important: When not using the USB power point, insert the rubber plug to prevent damage to the power point.

Key Switch

The key switch ([Figure 6](#)), is used to run and shut off the machine, and has 2 positions: ON and OFF. Rotate the key clockwise to the ON position to operate the machine. When the machine is stopped, rotate the key counterclockwise to the OFF position to shut off the machine. Remove the key whenever you leave the machine.

Supervisor Speed-Limit Switch

The supervisor speed-limit switch, located under the seat assembly, has 2 positions: PERFORMANCE and ECONOMY. Rotate the switch clockwise to the ECONOMY position to limit the maximum machine speed to 19 km/h (12 mph). Rotate the switch counterclockwise to the PERFORMANCE position to restore the maximum speed of the machine to 26 km/h (16 mph) as shown in [Figure 9](#).

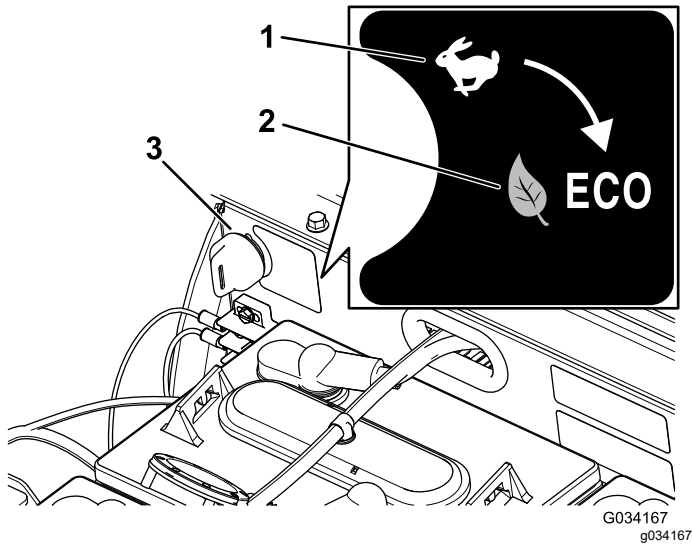

Figure 9

1. Performance position
2. Economy position
3. Supervisor speed-limit switch

Status-Indicator Light

The status-indicator light is located to the right of the parking-brake lever on the control panel ([Figure 6](#)).

When the machine is turned on, the green status-indicator light illuminates either solid or blinking.

If the light is solid, this indicates that the machine is ready for normal operation. If the light is blinking, there is an issue that needs to be resolved before continuing with normal operation of the machine.

If the status-indicator light blinks 2 times, this indicates that the parking brake is engaged while in the FORWARD or REVERSE position on the direction selector. Disengage the parking brake to shut off the status-indicator light.

Refer to [Troubleshooting \(page 48\)](#) if the status-indicator light blinks more than 2 times.

Passenger Handholds

The passenger handholds are located on the outside of each seat ([Figure 10](#)).

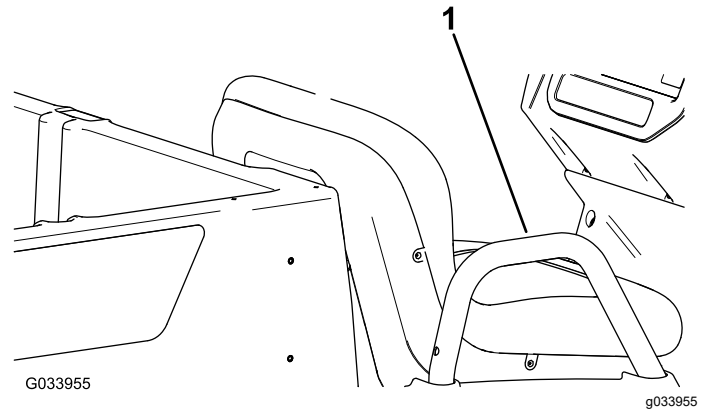

Figure 10

Passenger Side Shown

1. Passenger handhold

Specifications

Note: Specifications and design are subject to change without notice.

Base weight	Dry 633 kg (1,395 lb)
Rated capacity (on level ground)	544 kg (1,200 lb) total, including 90.7 kg (200 lb) operator and 91 kg (200 lb) passenger, load, accessories, and attachments
Maximum gross vehicle weight (GVW)—on level ground	1177 kg (2,595 lb) total, including all of the weights listed above
Maximum cargo capacity (on level ground)	363 kg (800 lb) total, including rear-mounted accessories
Maximum rear cargo box accessory mount capacity	45 kg (100 lb) total
Tow capacity	Tongue weight 91 kg (200 lb) Maximum trailer weight 454 kg (1,000 lb)
Overall width	119 cm (47 inches)
Overall length	302 cm (119 inches)
Overall height	127.5 cm (50.2 inches)
Ground clearance	21.6 cm (8.5 inches) at the front with no load or operator, 14 cm (5.5 inch) at the rear with no load or operator
Wheel base	220 cm (86.6 inches)
Wheel tread (center line to center line)	119 cm (47 inches) in the front, 119 cm (47 inches) in the rear
Cargo box length	102 cm (40 inches) inside, 114.3 cm (45 inches) outside
Cargo box width	98 cm (38.5 inches) inside, 107.3 cm (42.3 inches) at outside of the molded fenders
Cargo box height	28 cm (11 inches) inside

*Specifications listed are with Trojan T-125 batteries.

**Installing non-standard batteries may reduce the cargo-box capacity.

Attachments/Accessories

A selection of Toro approved attachments and accessories is available for use with the machine to enhance and expand its capabilities. Contact your Authorized Service Dealer or Distributor or go to www.Toro.com for a list of all approved attachments and accessories.

Operation

Note: Determine the left and right sides of the machine from the normal operating position.

Think Safety First

Carefully read all safety instructions and symbols in the safety section. Knowing this information could help you or bystanders avoid injury.

⚠ DANGER

Operating on wet grass or steep slopes can cause sliding and loss of control.

Wheels dropping over edges can cause rollovers, which may result in serious injury, death, or drowning.

To avoid loss of control and possibility of rollover:

- Do not operate near dropoffs or near water.
- Reduce speed and use extreme caution on slopes.
- Avoid sudden turns or rapid speed changes.

Operating the Cargo Box

Raising the Cargo Box to the Dump Position

⚠ WARNING

A raised box could fall and injure persons that are working beneath it.

- Always use the prop rod to hold the box up before working under the box.
- Remove any load material from the box before raising it.

⚠ WARNING

Driving the machine with the cargo box raised may cause the machine to tip or roll easier. The box structure may become damaged if you operate the machine with the box raised.

- Operate the machine only when the cargo box is down.
- After emptying the cargo box, lower it.

⚠ CAUTION

If a load is concentrated near the back of the cargo box when you release the latches, the box may unexpectedly tip open, injuring you or bystanders.

- Center loads in the cargo box, if possible.
- Hold the cargo box down and ensure that no one is leaning over the box or standing behind it when releasing the latches.
- Remove all cargo from the box before lifting the box up to service the machine.

1. Pull the lever on left, inside of the cargo box toward you and lift the cargo box up (Figure 11).

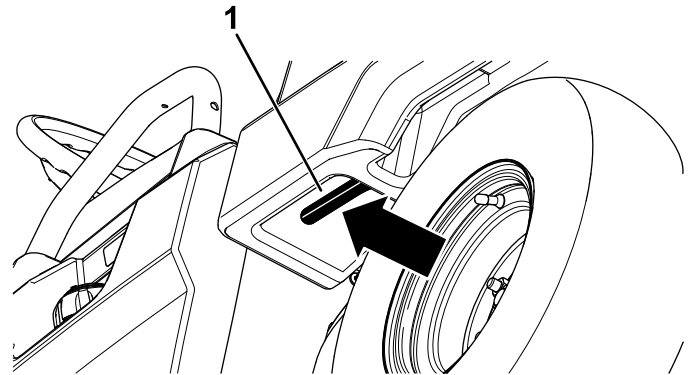

G034019
g034019

Figure 11

1. Cargo-box lever

2. Pull the prop rod into the dump position detent slot, securing the box for dumping (Figure 12).

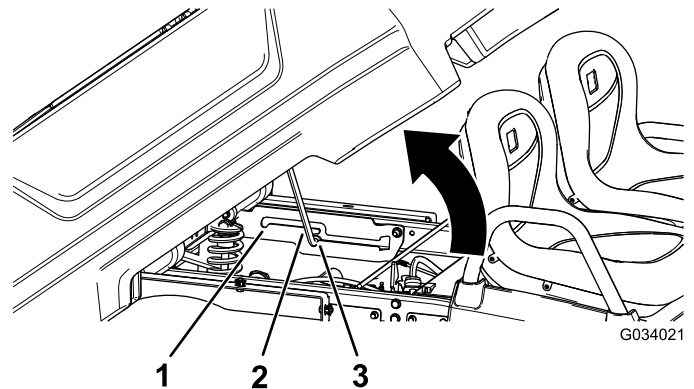

G034021

g034021

Figure 12

1. Service position detent slot
2. Prop rod
3. Dump position detent slot

Raising the Cargo Box to the Service Position

1. Pull the lever on left, inside of the cargo box toward you and lift the cargo box up (Figure 11).
2. Pull prop rod into the service position detent slot, securing the box for maintenance (Figure 12).

Lowering the Cargo Box

⚠ WARNING

The weight of the box may be heavy. Hands or other body parts could be crushed.

Keep hands and other body parts clear when lowering the box.

1. Raise the cargo box slightly by lifting up on the latch lever (Figure 11).
2. Pull the prop rod out of the detent slot (Figure 12).
3. Lower the box until it latches securely.

Opening the Tailgate

1. Ensure that the cargo box is down and latched.
2. Using both hands, raise the tailgate using the ridge near the top of the tailgate (Figure 13).
3. Lower the tailgate until it is flush with the bottom of the cargo box (Figure 13).

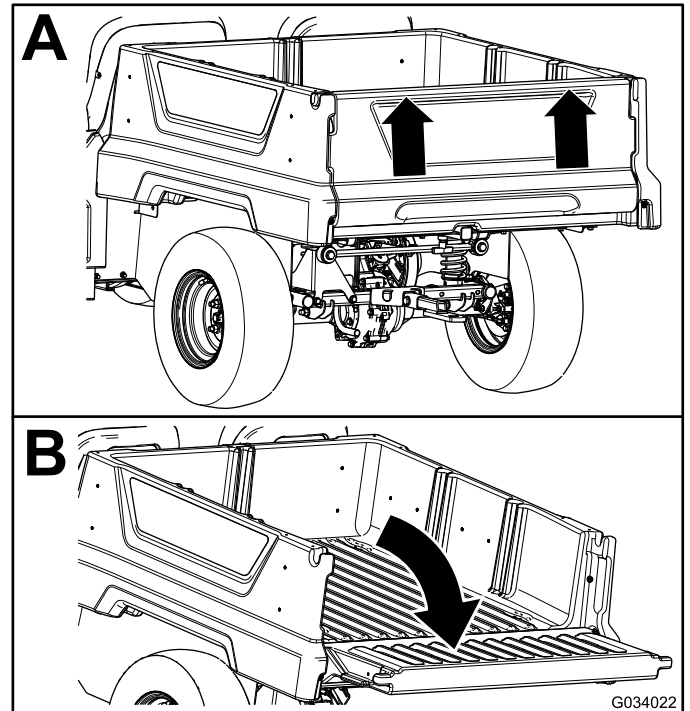

Figure 13

Closing the Tailgate

If you unloaded loose material such as sand, landscaping rock, or wood chips from the cargo box of the machine, some of the material that you unloaded may have lodged in the hinge area of the tailgate. Perform the following steps before closing the tailgate.

1. Remove as much of the material from the hinge area as possible.
2. Rotate the tailgate to approximately the 45° position (Figure 14).

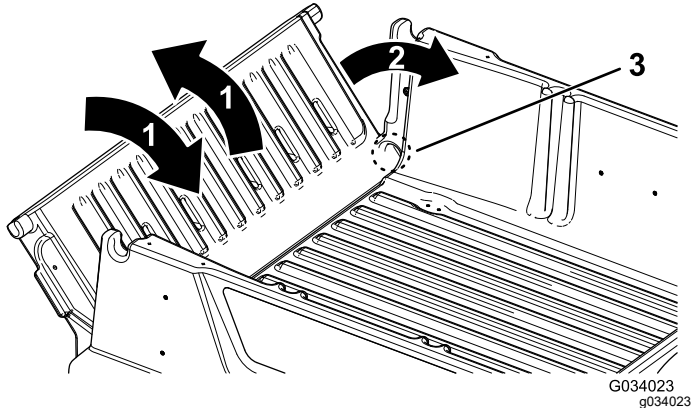

Figure 14

1. Rotate the tailgate back and forth several times.
 2. Rotate the tailgate to approximately the 45° position.
 3. Hinge area
-
3. Use a short, shaking motion to rotate the tailgate back and forth several times (Figure 14).
- Note:** This action helps move material away from the hinge area.
4. Lower the tailgate and check for material remaining in the hinge area.
 5. Repeat steps 1 through 4 until the material is removed from the hinge area.
 6. Rotate the tailgate up and lift the tailgate into the notches in the cargo box.

Using the Rear Cargo Box Accessory Mount

Use the rear cargo box accessory mount to attach accessories to the rear of the machine.

Capacity: 45 kg (100 lb)

1. Loosen the “T” handle by rotating it clockwise (Figure 15).

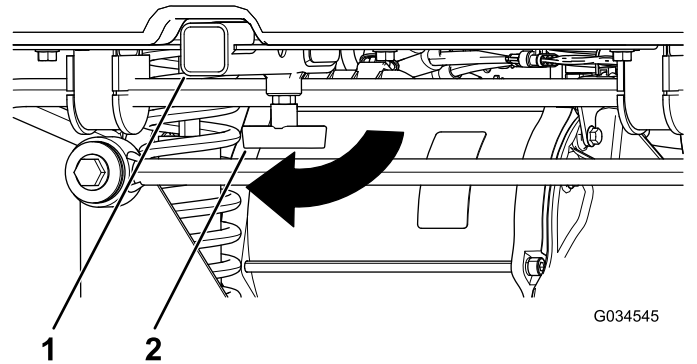

Figure 15

1. Receiver
2. “T” handle

2. Insert your accessory into the receiver until the holes align (Figure 15).
3. Secure the assembled accessory to the receiver tube using the clevis pin and hairpin cotter supplied with the accessory.
4. Tighten the “T” handle by rotating it counterclockwise (Figure 16).

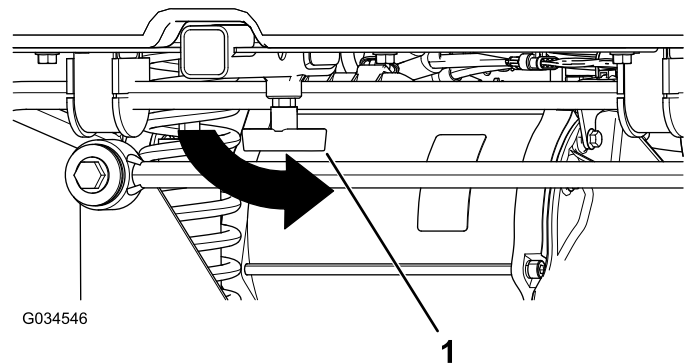

Figure 16

1. “T” handle

Performing Pre-Starting Checks

Service Interval: Before each use or daily Check the following items each time you begin using the machine for the day:

- Ensure that the batteries are charged before using the machine; [Charging the Batteries \(page 35\)](#).
- Check the water level in the batteries; [Checking the Water Level of the Batteries \(page 36\)](#).
- Check brake-fluid level, and add the specified brake fluids as needed; refer to [Checking the Brake-Fluid Level \(page 44\)](#).
- Check the air pressure in the tires; refer to [Checking the Tire Pressure \(page 22\)](#).
- Check the brake pedal operation.
- Check to see that the lights are working.
- Turn the steering wheel to the left and right to check steering response.
- Check for loose parts and any other noticeable malfunctions.

Note: Shut off the machine and allow all moving parts to stop before checking for loose parts and other wear and damage.

If any of the above items are not correct, notify your mechanic or check with your supervisor before taking the machine out for the day. Your supervisor may want you to check other items on a daily basis, so ask him or her about additional operator's responsibilities.

Checking the Tire Pressure

Service Interval: Before each use or daily

Tire Air Pressure Range: 165 to 207 kPa (24 to 30 psi)

Important: Do not exceed the maximum air pressure indicated on the sidewall of the tire.

Note: The air pressure needed in the tires is determined by the payload that you intend to carry.

1. Check the air pressure in the tires.

Note: The air pressure range in the front and rear tires is 165 to 207 kPa (24 to 30 psi).

- Use lower air pressure in the tires for lighter payloads, for less the soil compaction, for a smoother the ride, and to minimize tire marks in the ground.
 - Use higher air pressure in the tires for carrying heavier payloads at higher speeds.
2. If needed, adjust the air pressure in the tires by adding or removing air in the tires.

Understanding and Using the Battery System

Understanding Deep-Cycle Batteries

The machine contains 8 deep-cycle, lead-acid batteries that supply power to the motor and accessories. A deep-cycle battery is not the same as an automobile battery. An automobile battery is designed to provide a surge of power to start the machine and moderate power to run the lights and accessories when the motor if off or idling. The alternator then continuously charges as the automobile runs. As such, an automobile battery seldom drops below 90% of the maximum charge level.

A deep-cycle battery is designed to be a primary power source to provide a sustained output. Deep-cycle batteries are typically discharged as low as 20 to 30% of the maximum charge level. A discharge this low is considered a deep discharge.

Important: Repeated deep-discharge cycles reduces the battery life.

Lead-acid batteries produce electricity through a chemical reaction between lead plates and sulfuric acid. Charging a battery reverses the chemical reaction, allowing the battery to once again produce electricity.

A battery is a perishable item that has a limited lifetime ([Figure 17](#)). When a battery is new, it requires a break-in period to establish efficient electrical production. This break in period usually requires 100 to 150 discharge/charge cycles.

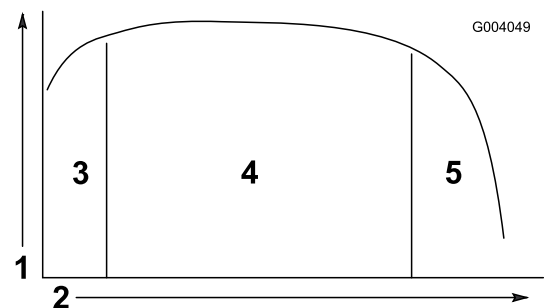

Figure 17
Battery-Lifetime Table

- | | |
|--|----------------------------|
| 1. Battery capacity | 4. Prime battery life |
| 2. Discharge/charge cycles | 5. End of the battery life |
| 3. Break-in period (100 to 150 cycles) | |

After the break-in period, the battery maintains a high capacity for many cycles. The number of cycles that a battery performs depends on the following:

- Battery maintenance—improper maintenance severely reduces the life of the batteries.
- Depth of discharge between charge cycles—**the deeper the batteries are discharged on a regular basis between charges, the shorter the service life the batteries will have.**
- Charge frequency—fully charge the batteries whenever possible.

Important: Fully discharging the batteries damages them and reduces their life.

- Low water levels—if the lead plates become exposed, it may permanently damage the batteries. Perform the following to maintain the electrolyte level:

After fully charging the batteries, fill the batteries with distilled or deionized water; refer to [Checking the Water Level of the Batteries](#) (page 36) and [Adding Distilled or Deionized Water to the Batteries](#) (page 37).

Important: Fully charge the batteries before adding the water to the batteries. While charging, the electrolyte increases in volume, and filling a low battery before fully charging the batteries can cause the electrolyte to overflow and leak out of the vent.

At the end of the battery life, the batteries gradually lose electric capacity.

Using the Battery System

When your batteries are fully charged, the tenth bar (far right) illuminates on the battery-discharge indicator ([Figure 18](#)).

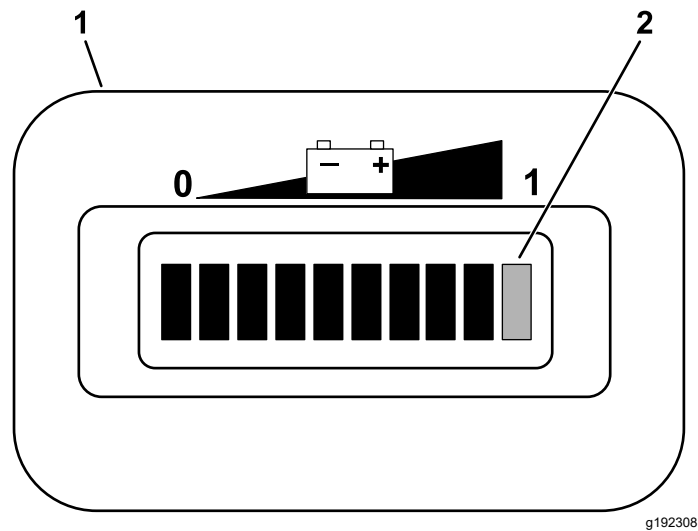

Figure 18

1. Battery-discharge indicator
2. Charge-indicator bars

As you use the machine, the bars disappear as the electrical capacity of the batteries is used.

When only the second bar from the left remains on the battery-discharge indicator, it is a good time to charge (Figure 19).

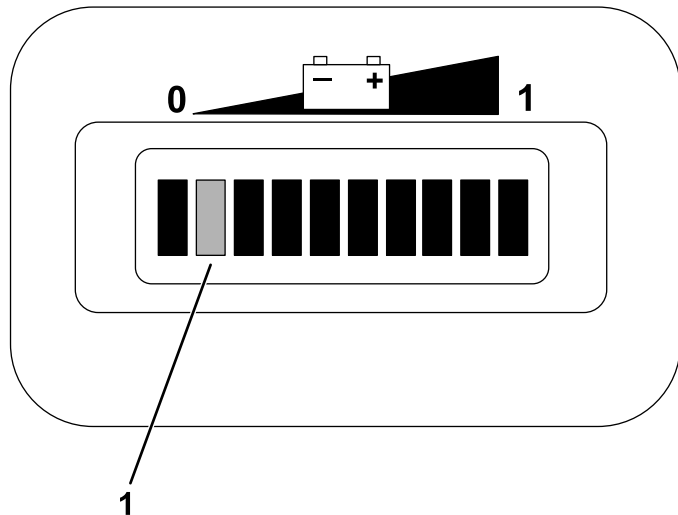

Figure 19

g192309

1. The 2 left bars alternately blink until you charge the batteries.

If you continue to use the machine with only 2 bars remaining, bars 1 and 2 alternately flash.

Important: When only the second bar from the left remains on the battery-discharge indicator, the machine may enter a reduced-speed mode; this mode aids in protecting the batteries, but prolonged operation in this mode can damage the batteries and/or the machine. Avoid draining your batteries down to the second bar from the left to prevent this issue. Charge the batteries immediately.

If the batteries become fully discharged, the machine shuts down. **Do not allow the batteries to become fully discharged.**

Important: To obtain maximum battery life, always charge the batteries before the charge reaches the second bar from the left on the screen. Regularly depleting the batteries to lower than the second bar from the left reduces the life of the batteries.

Stopping the Machine

Important: When stopping the machine on an incline, use the service brakes to stop the machine and engage the parking brake to hold the machine in place. Using the accelerator to stall the machine on the hill can overheat the motor or drain the batteries.

1. Remove your foot from the accelerator pedal.
2. Slowly press the brake pedal to apply the service brakes until the machine comes to a complete stop.

Note: The stopping distance may vary depending on the machine load and speed.

Parking the Machine

1. Stop the machine using the service brakes by pressing and holding the brake pedal.
2. Engage the parking brake by pulling the parking-brake lever toward you.
3. Rotate the key counterclockwise to the OFF position.
4. Remove the key.

Breaking in a New Machine

Service Interval: After the first 100 hours—Perform the breaking in a new machine guidelines.

Perform the breaking in a new machine guidelines to provide proper performance and long life for the machine.

- Check the brake fluid and the water level in the batteries regularly.
- Avoid hard braking situations for the first several hours of new machine break-in operation. New brake linings may not be at optimum performance until several hours of use has caused the brakes to become burnished (broken-in).
- Refer to [Maintenance \(page 27\)](#) for any special low hour checks.
- Check the front suspension positioning and adjust it if necessary.

Loading the Cargo Box

Use the following guidelines when loading the cargo box and operating the machine:

- Observe the weight capacity of the machine and limit the weight of the load that you carry in the cargo box as described in [Specifications \(page 18\)](#) and on the gross vehicle weight tag of the machine.
- **Note:** The load rating is specified for machine operation on a level surface only.
- Reduce the weight of the load that you carry in the cargo box when operating the machine on hills and rough terrain.
- Reduce the weight of the load that you carry when the materials are tall (and have a high center of gravity), such as a stack of bricks, landscaping timbers, or fertilizer bags. Distribute the load as low as possible, making sure that the load does not reduce your ability to see behind the machine when operating it.
- Keep loads centered by loading the cargo box as follows:
 - Evenly position the weight in the cargo box from side to side.

Important: Tipping over is more likely to occur if the cargo box is loaded to 1 side.

- Evenly position the weight in the cargo box from front to back.

Important: Loss of steering control or the machine may tip over if you position the load behind the rear axle and the traction on the front tires is reduced.

- Use extra caution when transporting oversized loads in the cargo box, particularly when you cannot center the weight of the oversize load to the cargo box.
- Whenever possible, secure the load by binding it to the cargo box so it does not shift.
- When transporting liquid in a large tank (such as a sprayer tank), use caution when driving the machine up hill or down hill, when suddenly changing speed or stopping, or when driving over tough surfaces.

The capacity of the cargo box is 0.28 m³ (10 ft³). The amount (volume) of material that you can place in the box without exceeding the load ratings of the machine can vary greatly depending on the density of the material.

See the following table for load volume limits with various materials:

Material	Density	Maximum Cargo Box Capacity (on level ground)
Gravel, dry	1522 kg/m ³ (95 lb/ft ³)	Full
Gravel, wet	1922 kg/m ³ (120 lb/ft ³)	3/4 Full
Sand, dry	1442 kg/m ³ (90 lb/ft ³)	Full
Sand, wet	1922 kg/m ³ (120 lb/ft ³)	3/4 full
Wood	721 kg/m ³ (45 lb/ft ³)	Full
Bark	<721 kg/m ³ (<45 lb/ft ³)	Full
Earth, packed	1602 kg/m ³ (100 lb/ft ³)	3/4 Full (approximately)

Transporting the Machine

Use a trailer with full-width ramps to move the machine a long distance. Make sure that the machine is securely bound to the trailer. Refer to [Figure 20](#) and [Figure 21](#) for the location of the tie-down points on the machine.

⚠ CAUTION

Loose seats may fall off the machine and trailer when transporting the machine, and the seats may land on another machine or obstruct the roadway.

Remove the seats or make sure that the seats are securely fastened to the coupling in the seat shroud.

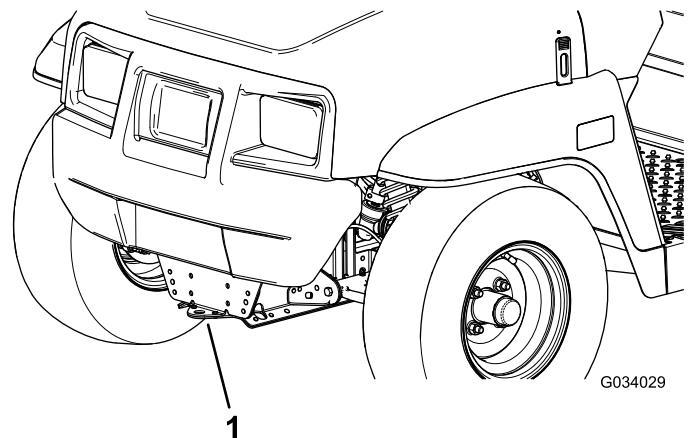

Figure 20

1. Towing tongue and tie-down point (front of the machine)

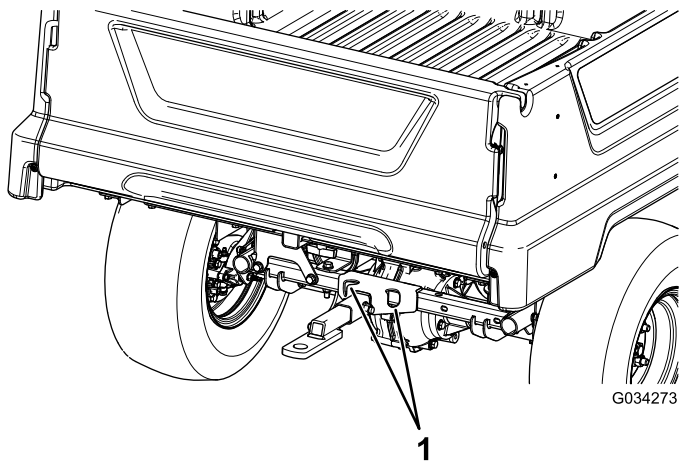

Figure 21

1. Rear tie-down points

Towing the Machine

In case of an emergency, the machine can be towed for a short distance. However, we do not recommend this as a standard operating procedure.

⚠ WARNING

Towing at excessive speeds could cause a loss of steering control, resulting in personal injury.

Never tow the machine faster than 8 km/h (5 mph).

Towing the machine is a 2-person job. If the machine must be moved a considerable distance, transport it on a truck or trailer; refer to [Transporting the Machine \(page 25\)](#).

1. Shut off the machine and remove the key.

Important: If you tow the machine with the key in the ON position, the electrical system may be damaged.

2. Affix a tow line to the tongue at the front of the machine's frame ([Figure 20](#)).
3. Disengage the parking brake.

Towing a Trailer

The machine is capable of pulling trailers.

When hauling cargo or towing a trailer, do not overload your machine or trailer. Overloading either the machine or the trailer can cause poor performance or damage to the brakes, axle, motor, transaxle, steering, suspension, body structure, or tires. Always load a trailer with 60% of the cargo weight in the front of the trailer. This places approximately 10% of the gross trailer weight (GTW) on the tow hitch of the machine.

The maximum cargo load shall not exceed 454 kg (1,000 lb), including the GTW. For example, if the GTW is 181.5 kg (400 lb) then the maximum cargo load is 544 kg (1,200 lb) including operator(s).

To provide adequate braking and traction, always load the cargo box when trailering. Do not exceed the GTW or GVW limits.

Avoid parking a machine with a trailer on a hill. If you must park on a hill, engage the parking brake and block the tires of the trailer.

Maintenance

Note: Download a copy of the electrical schematic by visiting www.Toro.com and searching for your machine from the Manuals link.

Note: Determine the left and right sides of the machine from the normal operating position.

Recommended Maintenance Schedule(s)

Maintenance Service Interval	Maintenance Procedure
After the first 100 hours	<ul style="list-style-type: none">• Perform the breaking in a new machine guidelines.
Before each use or daily	<ul style="list-style-type: none">• Perform the pre-starting checks. Check the following items each time you begin using the machine for the day:• Check the tire pressure.• Charge the batteries.• Check the water level of the batteries.• Check the brake-fluid level.
Every 25 hours	<ul style="list-style-type: none">• Clean the batteries.• Check the water level of the batteries and add distilled or deionized water to the batteries (if necessary).
Every 100 hours	<ul style="list-style-type: none">• Grease the bearings and bushings.• Check the condition of the tires and rims.• Torque the wheel-lug nuts.• Inspect the steering and suspension for loose or damaged components.• Check the front wheel toe-in.• Check the transaxle for leaks.• Inspect the brakes.
Every 300 hours	<ul style="list-style-type: none">• Grease the front wheel bearings.
Every 400 hours	<ul style="list-style-type: none">• Replace the service and parking-brake pads.
Every 800 hours	<ul style="list-style-type: none">• Change the transaxle fluid.
Every 1,000 hours	<ul style="list-style-type: none">• Change the brake fluid.

Daily Maintenance Checklist

Duplicate this page for routine use.

Maintenance Check Item	For the week of:						
	Monday	Tuesday	Wednesday	Thursday	Friday	Saturday	Sunday
Check brake and parking brake operation.							
Check gear shift/neutral operation.							
Check the water level of the batteries.							
Check brake-fluid level.							
Check unusual operating noises.							
Check tire pressure.							
Check fluid leaks.							
Check instrument operation.							
Check accelerator operation.							
Lubricate all grease fittings.							
Touch up damaged paint.							

▲ WARNING

A raised cargo box can fall and injure persons that are underneath it.

You must raise the cargo box to perform some routine maintenance.

- **Always use the prop rod to hold the cargo box up before working under it.**
- **Remove any load material from the cargo box before working under it.**

▲ CAUTION

If you leave the key in the key switch, someone could accidentally start the machine and seriously injure you or other bystanders.

Remove the key from the key switch and disconnect a battery cable before you do any maintenance.

Pre-Maintenance Procedures

Maintaining the Machine under Special Operating Conditions

If the machine is subjected to any of the conditions listed below, maintenance should be performed twice as frequently.

- Desert operation
- Cold climate operation—below 10°C (50°F)
- Trailer towing
- Frequent operation in dusty conditions
- Construction work
- After extended operation in mud, sand, water, or similar dirty conditions, have your brakes inspected and cleaned as soon as possible. This prevents any abrasive material from causing excessive wear.

Preparing to Maintain the Machine

1. Park the machine on a level surface.
2. Engage the parking brake.
3. Shut off the machine and remove the key.

Lifting the Machine

▲ DANGER

The machine may be unstable when using a jack. It could slip off the jack, injuring anyone beneath it.

- Do not start the machine while the machine is on a jack.
- Always remove the key from the key switch before getting off the machine.
- Block the tires when the machine is supported by lifting equipment.
- Use jack stands to support the machine once you have lifted the it.

Important: Whenever the machine is ran for routine maintenance and/or diagnostics, the rear wheels of the machine should be 25 mm (1 inch)

off the ground, with the rear axle supported on jack stands.

- The lifting point at the front of the machine is at the front of the frame behind the towing tongue (Figure 22).

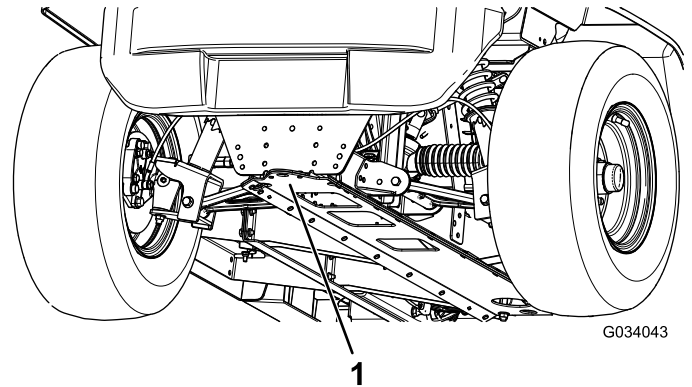

Figure 22

1. Front lifting point

- The lifting point at the rear of the machine is under the axle tubes (Figure 23).

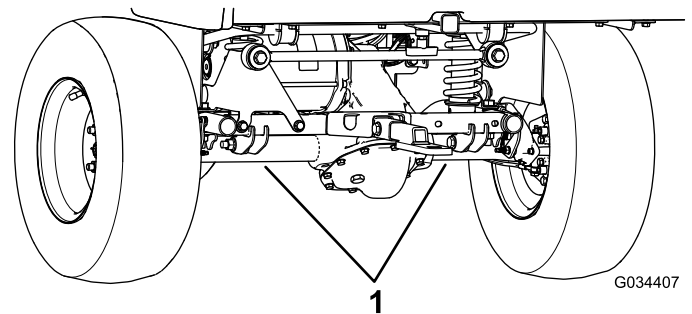

Figure 23

1. Rear lifting points

Accessing the Hood

Raising the hood

1. Lift up the handle of the rubber latches at each side of the hood (Figure 24).

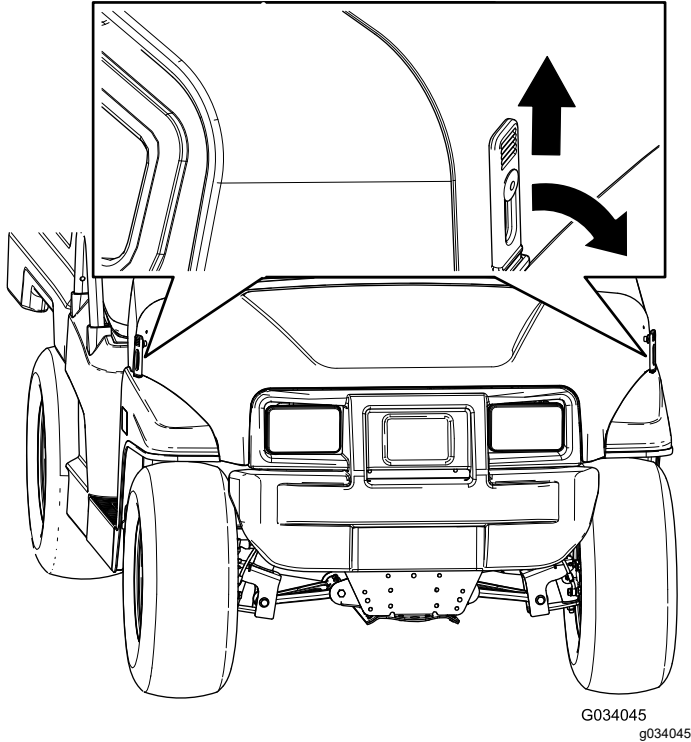

Figure 24

2. Raise the hood.

Closing the Hood

1. Gently lower the hood onto the chassis.
2. Secure the hood by aligning the rubber latches onto the latch anchors at each side of the hood (Figure 24).

Raising and Lowering the Seat Assembly

To raise the seat assembly, push the seat assembly forward until it rests on the steering wheel (Figure 25).

To lower the seat assembly, push the seat assembly rearward until it seats back into the original position (Figure 25).

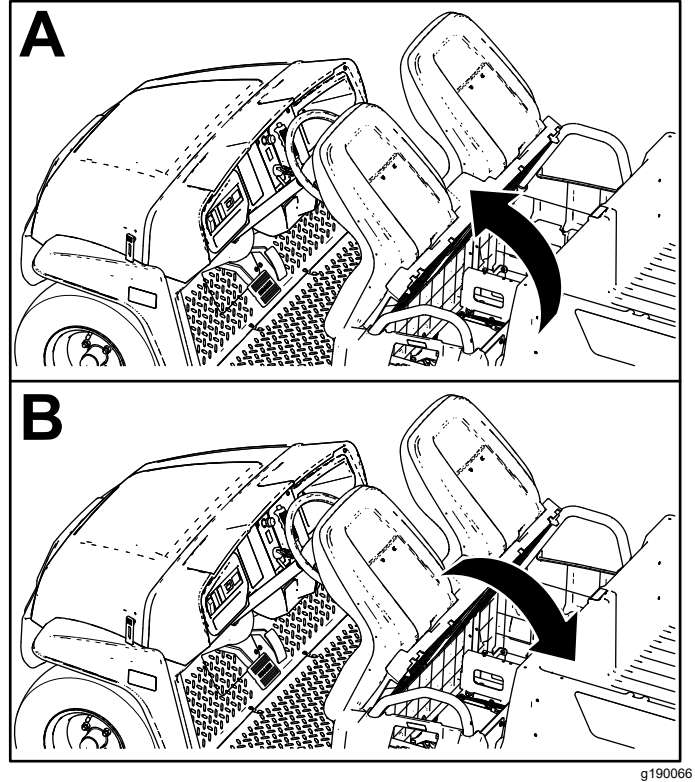

Figure 25

Removing the Seat Assembly

1. Push the seat assembly forward to the raised position (Figure 25).
2. Slide the seat assembly to the side out of the pins, and lift the seat assembly upward (Figure 26).

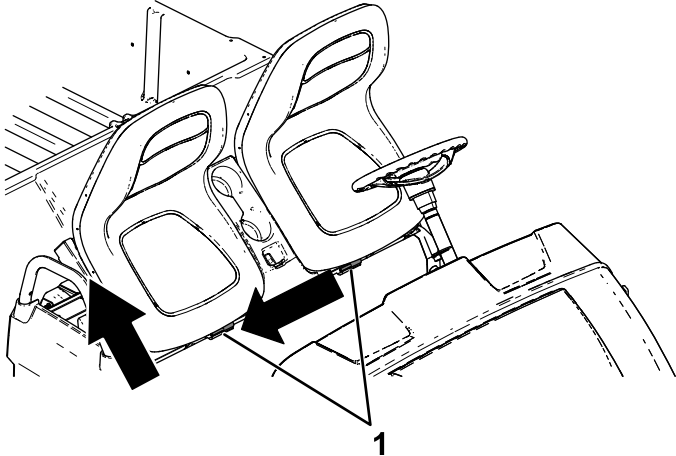

Figure 26

g190187

1. Pins

Installing the Seat Assembly

Slide the seat assembly onto the pins and lower the seat assembly (Figure 27).

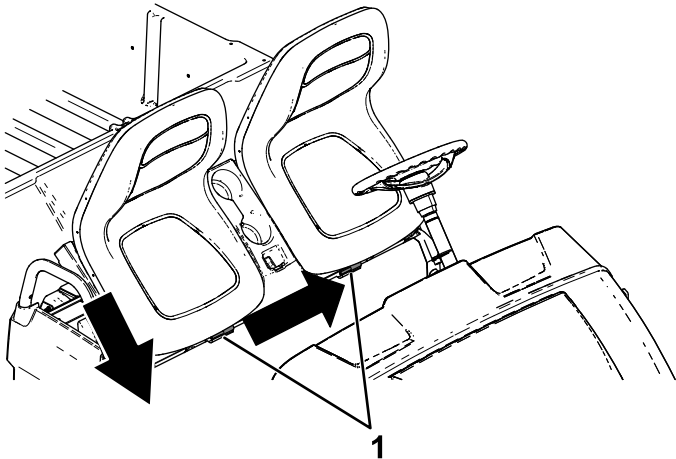

Figure 27

g190186

1. Pins

Lubrication

Greasing the Machine

Service Interval: Every 100 hours/Yearly (whichever comes first)—Grease the bearings and bushings. Grease the machine more frequently when using it for heavy-duty operations.

Grease Type: No. 2 lithium grease

1. Use a rag to wipe the grease fitting clean so that foreign matter cannot be forced into the bearing or bushing.
2. With a grease gun, apply 1 or 2 pumps of grease into the grease fittings on the machine.
3. Wipe the excess grease off the machine.

The grease fittings are located at the inner end of the control arms, the tie-rod ball joint, and the outer end of the control arms (Figure 28 and Figure 29).

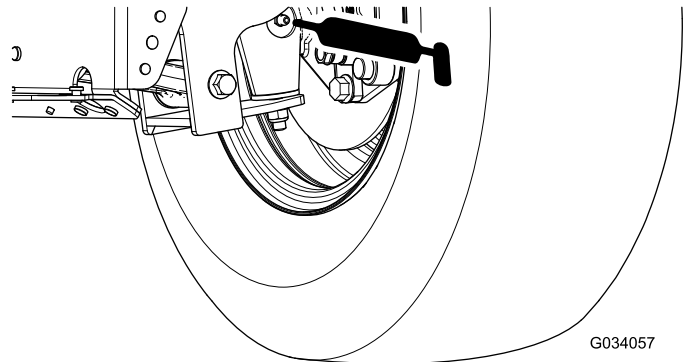

Figure 28

g034057

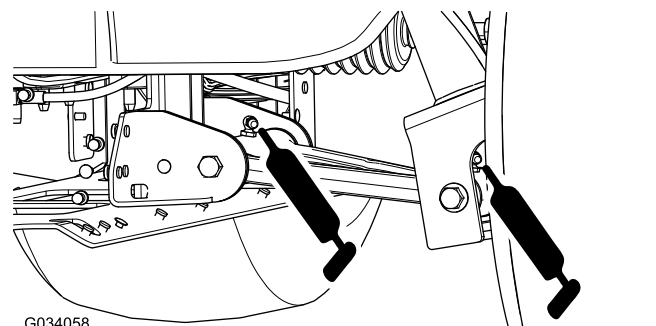

Figure 29

g034058

Greasing the Front Wheel Bearings

Service Interval: Every 300 hours

Grease specification: Mobilgrease XHP™-222

Removing the Hub and Rotor

1. Lift the front of the machine and support it with jack stands.
2. Remove the 4 lug nuts that secure the wheel to the hub (Figure 30).

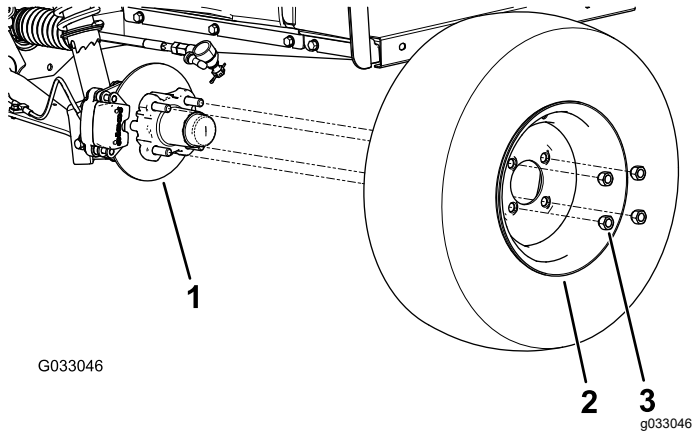

Figure 30

1. Hub
2. Wheel
3. Lug nut

3. Remove the flange-head bolts (3/8 x 3/4 inch) that secure the bracket for the brake assembly to the spindle and separate the brake from the spindle (Figure 31).

Note: Support the brake assembly before proceeding to the next step.

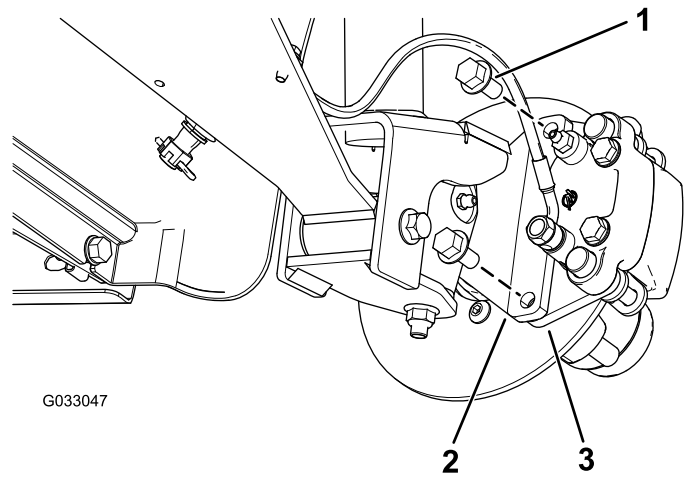

Figure 31

1. Flange-head bolts (3/8 x 3/4 inch)
2. Spindle
3. Caliper bracket (brake assembly)

4. Remove the dust cap from the hub (Figure 32).

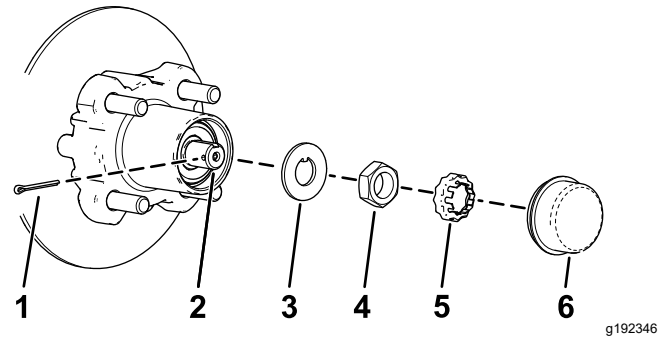

Figure 32

1. Cotter pin
2. Spindle
3. Tab washer
4. Spindle nut
5. Nut retainer
6. Dust cap

5. Remove the cotter pin and nut retainer from the spindle and spindle nut (Figure 32).
6. Remove the spindle nut from the spindle, and separate the hub and rotor assembly from the spindle (Figure 32 and Figure 33).

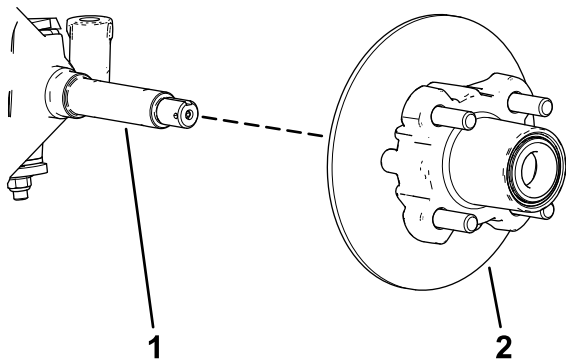

Figure 33

g192347

1. Spindle
2. Hub and rotor assembly

7. Wipe clean the spindle with a rag.
8. Repeat steps 1 through 7 to the hub and rotor at the other side of the machine.

Greasing the Wheel Bearings

1. Remove the outboard bearing and bearing race from the hub (Figure 34).

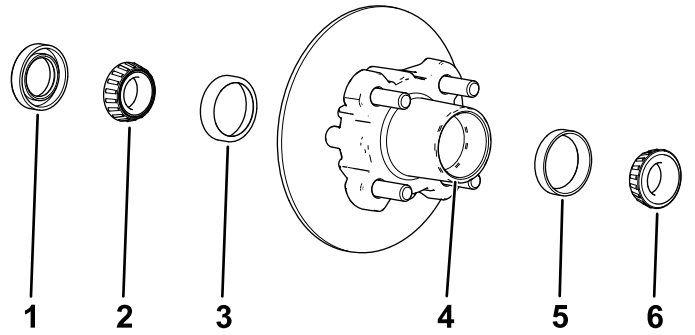

G033050
g033050

Figure 34

1. Seal
2. Inboard bearing
3. Inboard-bearing race
4. Bearing cavity (hub)
5. Outboard-bearing race
6. Outboard bearing

2. Remove the seal, inboard bearing from the hub (Figure 34).
3. Wipe clean the seal and check for wear and damage.

Note: Do not use cleaning solvent to clean the seal. Replace the seal if it is worn or damaged.

4. Clean the bearings and races, and check these parts for wear and damage.

Note: Replace all worn or damaged parts. Ensure that the bearings and races are clean and dry.

5. Clean the cavity of the hub of all grease, dirt, and debris (Figure 34).
6. Pack the bearings with the specified grease.
7. Fill the cavity of hub 50 to 80% full of the specified grease (Figure 34).
8. Assemble the inboard bearing onto the race at the inboard side of the hub and install the seal (Figure 34).
9. Repeat steps 1 through 8 to the bearings for the other hub.

Installing the Hub and Rotor

1. Apply a light coat of the specified grease to the spindle (Figure 35).

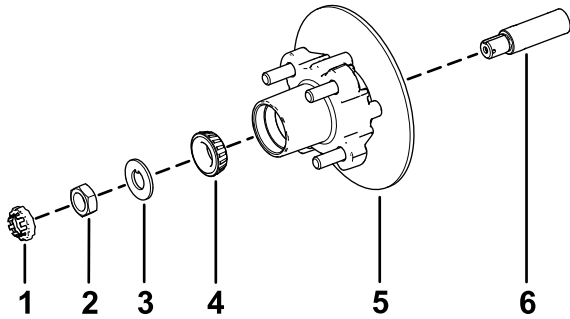

Figure 35

g192344

- | | |
|-----------------|--|
| 1. Nut retainer | 4. Outer bearing |
| 2. Spindle nut | 5. Hub, rotor, inner bearing, race, and seal |
| 3. Tab washer | 6. Spindle |
2. Assemble the hub and rotor onto the spindle with the rotor inboard (Figure 35).
 3. Assemble the outboard bearing onto the spindle and seat the bearing to the outboard race (Figure 35).
 4. Assemble the tab washer onto the spindle (Figure 35).
 5. Thread the spindle nut onto the spindle and tighten the nut to 15 N·m (11 ft-lb), while rotating the hub to seat the bearing (Figure 35).
 6. Loosen the spindle nut until the hub rotates freely.
 7. Torque the spindle nut to 170 to 225 N·cm (15 to 20 in-lb).
 8. Install the retainer over the nut and check the alignment of the slot in the retainer and the hole in the spindle for the cotter pin (Figure 36).

Note: If the slot in the retainer and the hole in the spindle are not aligned, tighten the spindle nut to align the slot and hole to a maximum torque of 226 N·cm (20 in-lb) on the nut.

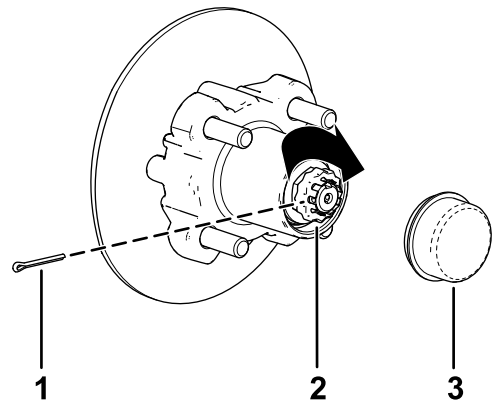

Figure 36

g192345

- | | |
|-----------------|-------------|
| 1. Cotter pin | 3. Dust cap |
| 2. Nut retainer | |
9. Install the cotter pin and bend each leg around the retainer (Figure 36).
 10. Install the dust cap onto the hub (Figure 36).
 11. Repeat steps 1 through 10 for the hub and rotor at the other side of the machine.

Installing the Brakes and Wheels

1. Clean the 2 flange-head bolts (3/8 x 3/4 inch) and apply a coat of medium-strength thread-locking compound to the threads of the bolts.
2. Align the brake pads to either side of the rotor (Figure 31) and the holes in the caliper bracket with the holes in the brake mount of the spindle frame (Figure 35).
3. Secure the caliper bracket to the spindle frame (Figure 31) using the 2 flange-head bolts (3/8 x 3/4 inch).

Torque the 2 flange-head bolts to 47 to 54 N·m (35 to 40 ft-lb).

4. Align the holes in the wheel to the studs of the hub and assemble the wheel to the hub with the valve stem outward (Figure 30).

Note: Ensure that the mounting surface of the wheel is flush with the hub.

5. Secure the wheel to the hub using the lug nuts (Figure 30).
Torque the lug nuts to 108 to 122 N·m (80 to 90 ft-lb).
6. Repeat steps 1 through 5 for the brake and wheel on the other side of the machine.

Electrical System Maintenance

Maintaining the Batteries

Raise the seat assembly and raise the cargo box before maintaining the batteries; refer to [Raising and Lowering the Seat Assembly \(page 30\)](#) and [Raising the Cargo Box to the Service Position \(page 20\)](#).

⚠ WARNING

Battery terminals or metal tools could short against metal components causing sparks. Sparks can cause the battery gases to explode, resulting in personal injury.

- When removing or installing the battery, do not allow the battery terminals to touch any metal parts of the machine.
- Do not allow metal tools to short between the battery terminals and metal parts of the machine.
- Use non-conductive tools when maintaining the batteries.
- Always keep the battery retainers in place to protect and secure the batteries.

⚠ DANGER

Do not touch any electrical components or contacts on the motor.

Touching any of these components or contacts could seriously injure you or cause death.

Cleaning the Batteries

Service Interval: Every 25 hours

1. Ensure that all the battery caps are tight.
2. Use a paper towel to clean the batteries.
3. If the battery terminals are corroded, clean them with a solution of 4 parts water and 1 part baking soda. Also, clean the posts and cable clamps with a post and clamp cleaner.

Note: The posts and clamps should have a bright, metallic shine.

4. Apply a light coating of Toro battery-terminal protector.

Charging the Batteries

Service Interval: Before each use or daily

The charger for this machine is located inside the machine under the operator's seat. For maximum battery life, charge the batteries whenever you are not using the machine. Depending on how discharged the batteries are and the ambient temperature of the batteries, it may take up to 16 hours to charge the batteries to full capacity.

Note: Normal charge time is approximately 8 to 10 hours.

Important: Lead-acid batteries do not develop a charge memory and do not need to be fully discharged before charging them. *Fully discharging the batteries may damage them.* Charge the batteries any time the machine is not in use.

⚠ WARNING

Charging the battery produces gases that can explode.

Never smoke near the batteries and keep sparks and flames away from them.

1. Position the machine in a well-ventilated area near a suitable power outlet.
2. Check the electrolyte level of the batteries.

Note: After fully charging the batteries, fill the batteries with distilled or deionized water; refer to [Adding Distilled or Deionized Water to the Batteries \(page 37\)](#).

Important: Fully charge the batteries before adding the water to the batteries. While charging, the electrolyte increases in volume, and filling a low battery before fully charging the batteries can cause the electrolyte to overflow and leak out of the vent.

3. Connect a **16 gauge (or larger diameter), 2.5 m (8.2 ft) or shorter charger cord** to the charging receptacle on the machine ([Figure 37](#)).

Note: Ensure that the charger-voltage setting matches the voltage at the power outlet being used.

Note: In high-ambient temperature environments, remove the seat assembly for optimal charging time; refer to [Removing the Seat Assembly \(page 31\)](#). If the battery charger is too hot, it may not charge properly. In cold temperatures, it may take a longer for the batteries to charge.

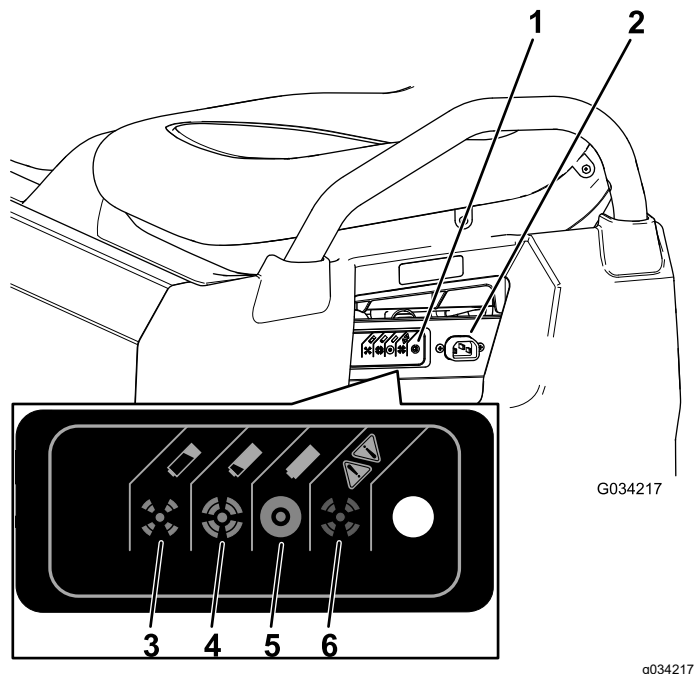

Figure 37

- | | |
|-------------------------------|--|
| 1. Charger-status light | 4. The battery is almost charged. |
| 2. Charging receptacle | 5. The battery is charged. |
| 3. The battery is near empty. | 6. Charger fault; refer to the charger manual for the fault codes. |

4. Plug the charger power cord into the power outlet.

Note: While the batteries are charging, the green light on the charger blinks on and off. When the batteries are fully charged, the green light stops blinking and stays on.

5. Disconnect the cord from the power outlet.
6. Disconnect the charger from the machine.

Refer to the following table and [Figure 37](#) for information on the meanings of the varying colors of the charger-status light.

Charger-Status Light Table

Charger-Status Light Color	Solid/Flashing	Meaning
Green	Solid	Charging complete
Green	Flashing	Short flash—less than 80% charge Long flash—greater than 80% charge
Amber	Flashing	Reduced-power mode—low AC voltage or high internal charger temperature; charge immediately
Red	Flashing	Charger error—reset the charger power. If this error persists, refer to the blink codes in the charger manual

Checking the Water Level of the Batteries

Service Interval: Before each use or daily

1. Park the machine on a level surface, engage the parking brake, shut off the machine, remove the key, and raise cargo box; [Raising the Cargo Box to the Service Position \(page 20\)](#).
2. Raise the seat assembly to access the batteries; refer to [Raising and Lowering the Seat Assembly \(page 30\)](#).
3. Check the eyelets on each of the batteries to see if they are either black or white ([Figure 38](#)).

Note: Black eyelets indicate that the batteries are full of water. White eyelets indicate that water is needed for the batteries.

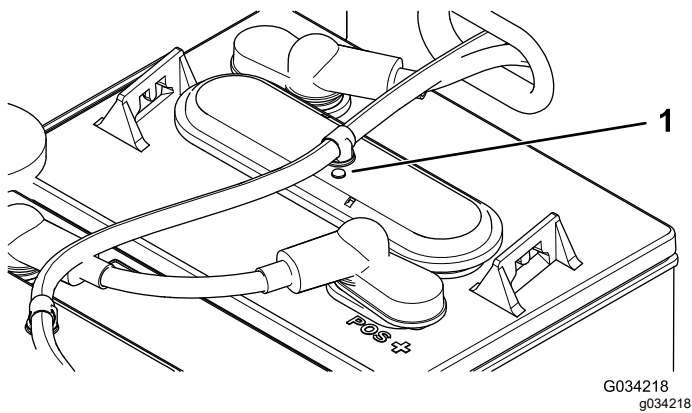

Figure 38

1. Battery eyelet

4. If the eyelets are white, you must add distilled or deionized water to the batteries; refer to [Adding Distilled or Deionized Water to the Batteries](#) (page 37).

Adding Distilled or Deionized Water to the Batteries

Service Interval: Every 25 hours/Every 2 weeks (whichever comes first)

Important: Fully charge the batteries before adding the water to the batteries. While charging, the electrolyte increases in volume, and filling a low battery before fully charging the batteries can cause the electrolyte to overflow and leak out of the vent.

Important: Use only clean, distilled or deionized water to fill the batteries. Using tap water may damage and reduce the life of the batteries.

1. Park the machine on a level surface, engage the parking brake, shut off the machine, remove the key, and raise cargo box; [Raising the Cargo Box to the Service Position](#) (page 20).
2. Charge the batteries until a full charge is achieved; refer to [Charging the Batteries](#) (page 35).
3. Raise the seat assembly to access the batteries; refer to [Raising and Lowering the Seat Assembly](#) (page 30).
4. Connect your Toro water hand pump to the water-fill port ([Figure 39](#)).

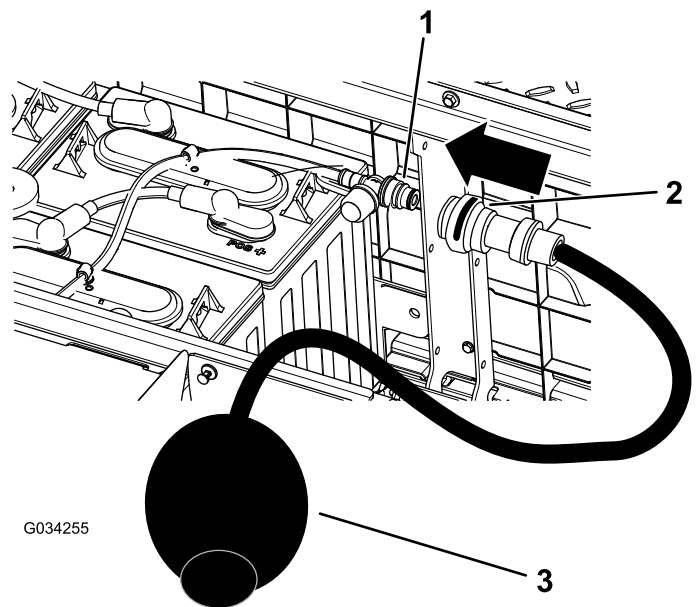

Figure 39

1. Water-fill port
2. Hand-pump connector
3. Water hand pump

5. Pump water into the water into batteries until all of the eyelets on top of the batteries are black, indicating that they are filled with water.

Important: Do not overfill the battery. Electrolyte will overflow onto other parts of the machine and severe corrosion and deterioration may result. Also, overfilling the battery may reduce the life of the battery.

Changing the Batteries

When the machine begins to lose operating range or when the length of time to discharge or charge the battery is significantly reduced, the batteries are probably wearing and losing their ability to hold a charge. Take the machine to an Authorized Service Dealer and have them test the batteries to determine whether the batteries need to be replaced. The dealer can then replace the batteries for you. If you wish to replace the batteries yourself, use the following procedures:

Disconnecting the Batteries

1. Raise the cargo bed, turn the key switch to the OFF position, and remove the key.
2. Disconnect the main negative-battery cable (black) that connects the bank of batteries to the ground point of the machine ([Figure 40](#)).

Note: The main battery cables are long when compared to battery-interconnect cables.

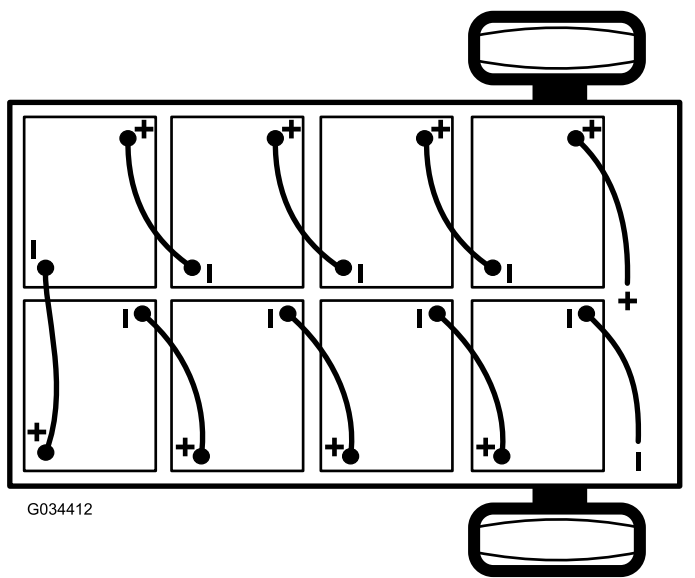

Figure 40

3. Disconnect the main positive-battery cable (red) that connects the bank of batteries to the main contactor of the machine (Figure 40).

Replacing the Batteries

1. Remove all of the battery-interconnect cables from the batteries.
2. Remove the battery retainers located between the batteries.
3. Remove all of the batteries and recycle them according to your local codes.
4. Assemble new batteries into the machine at the locations from where you removed batteries in step 3.

Note: Pay attention to the battery polarity when installing the new batteries (Figure 40).
5. Install the battery retainers and tighten the nuts until the retainer securely grips the batteries.
6. Connect the batteries together as shown in Figure 40 with the battery-interconnect cables that you removed in step 1.

Connecting the Batteries

1. Ensure that the battery terminals are clean and free of oxidation.
2. Connect the main positive-battery cable (red) between the bank of batteries and the machine (Figure 40).
3. Connect the main negative-battery cable (black) between the bank of batteries and the machine (Figure 40).
4. Torque the nuts securing all of the battery cables until the retainer securely grips the battery.
5. Coat the battery terminals with Toro battery-terminal protector.
6. Ensure that the rubber boots on each battery cable are securely seated over the battery terminals.
7. Insert the key into the key switch and rotate the switch to the ON position.
8. Lower the cargo box, rotate the key switch to the OFF position, and remove the key.

Storing the Batteries

Charge the batteries fully before placing the machine into storage. Plug the charger into a wall outlet while the machine and batteries are in storage. Leave the charger plugged into a wall outlet and charging receptacle during storage to ensure that the batteries stay charged and do not freeze; otherwise, charge the batteries at least once a month.

Important: If the machine cannot be plugged in during storage, fully charge the batteries at least once a month. The batteries self-discharge over long periods of time, which may damage the

batteries to the point of being unusable, even if the batteries are new.

Replacing the Fuses

There is 1 fuse in the electrical system; the other slots are open for options. They are located under the seat assembly behind a battery on the right side of the machine (Figure 41).

Optional lift kit—open	15 A
Main power	10 A
Horn—optional (standard on International models only)	30 A

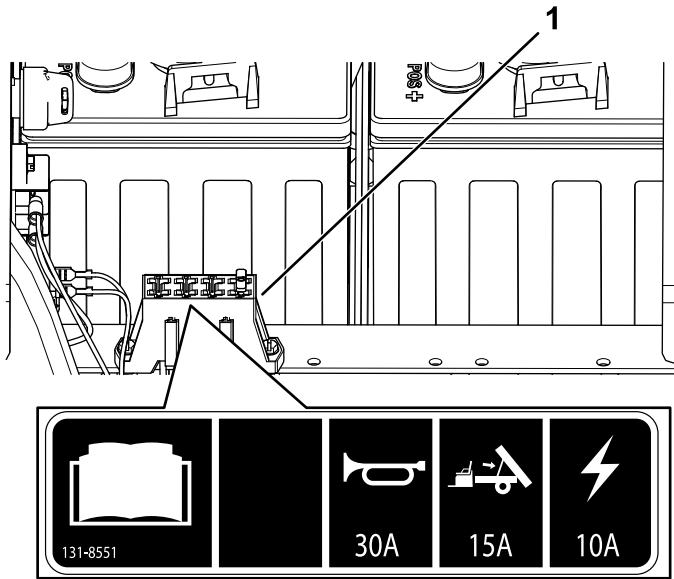

G036964

g036964

Figure 41

1. Fuse block

Maintaining the Headlights

Replacing the Bulbs

⚠ CAUTION

If you install a higher wattage bulb than the system is designed for, you may damage the 12 V power supply, or at a minimum, blow the fuse.

Always use the specified Toro LED bulb to prevent this issue.

⚠ CAUTION

The bulbs become extremely hot when in operation. Handling a hot bulb can cause severe burns and personal injury.

Always allow enough time for the bulbs to cool before replacing them. Use care whenever handling the bulb.

Specification: See your *Parts Catalog*.

1. Disconnect the batteries; refer to [Disconnecting the Batteries](#) (page 37).
2. Open the hood; refer to [Accessing the Hood](#) (page 30).
3. Disconnect the electrical connector for the harness from the connector of the lamp assembly at the back of the headlight housing (Figure 42).

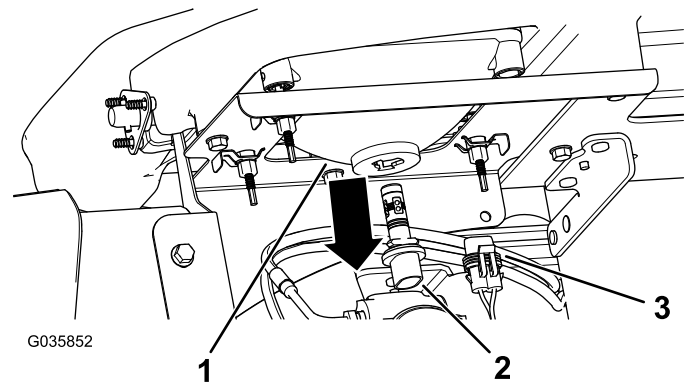

G035852

g035852

Figure 42

1. Headlight housing
2. Lamp assembly
3. Harness-electrical connector

4. Rotate the lamp assembly 1/4 turn counterclockwise and moving it rearward, out of the headlight housing (Figure 42).
5. Insert the new lamp assembly and headlight housing and align the tabs in the lamp assembly

- with the slots in the headlight housing ([Figure 42](#)).
- Secure lamp assembly by turning it 1/4 turn clockwise ([Figure 42](#)).
 - Connect the electrical connector for the harness to the connector of the new lamp assembly ([Figure 42](#)).
 - Connect the batteries and close the hood; refer to [Connecting the Batteries \(page 38\)](#).

Note: Ensure the adjustment posts are lined up with the holes in the mounting bracket behind the bumper.

- Secure the headlight assembly with the speed clips that you removed in step 4.
- Connect the electrical connector for the harness to the connector of the lamp assembly ([Figure 43](#)).
- Adjust the headlights to direct the beams to the desired position, refer to [Adjusting the Headlights \(page 40\)](#).

Replacing the Headlight

- Disconnect the batteries; refer to [Disconnecting the Batteries \(page 37\)](#).
- Open the hood; refer to [Accessing the Hood \(page 30\)](#).
- Disconnect the electrical connector for the harness from the connector of the lamp assembly ([Figure 43](#)).

Adjusting the Headlights

Use the following procedure to adjust the headlight beam position whenever a headlight assembly is replaced or removed.

- Turn the key switch to the ON position, and turn on the headlights.
- At the back of the headlight assembly, rotate adjustment screws ([Figure 43](#)) to pivot the headlight assembly and align the position of the cast beam.
- Connect the battery and close the hood; refer to [Connecting the Batteries \(page 38\)](#).

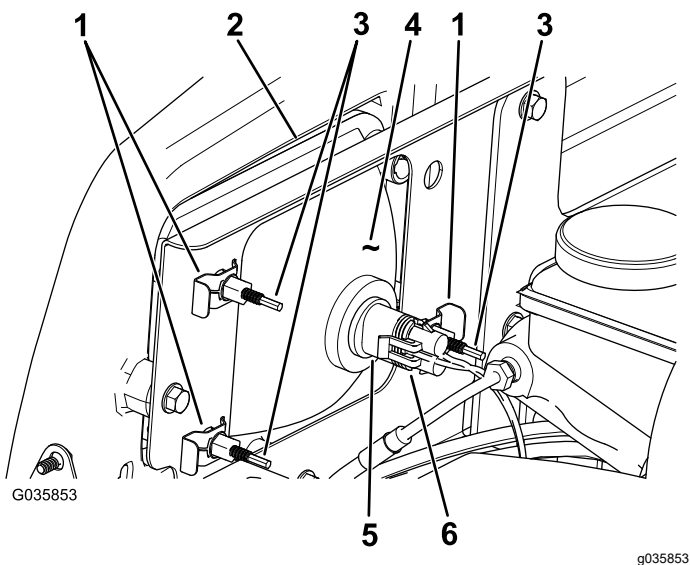

Figure 43

- | | |
|--------------------------|---------------------------------|
| 1. Speed clip | 4. Headlight |
| 2. Opening in the bumper | 5. Lamp assembly |
| 3. Adjustment screw | 6. Harness-electrical connector |

- Remove the speed clips that secure the headlight to the headlight bracket ([Figure 43](#)).

Note: Retain all parts for installation of the new headlight.

- Remove the headlight assembly by moving it forward through the opening in the front bumper ([Figure 43](#)).
- Install the new headlight through the opening in the bumper ([Figure 43](#)).

Drive System Maintenance

Maintaining the Tires

Service Interval: Every 100 hours—Check the condition of the tires and rims.

Every 100 hours—Torque the wheel-lug nuts.

1. Inspect the tires and rims for signs of wear and damage.

Note: Operating accidents, such as hitting curbs, can damage a tire or rim and also disrupt wheel alignment, so inspect tire condition after an accident.

2. Torque the wheel-lug nuts to 108 to 122 N·m (80 to 90 ft-lb).

Inspecting the Steering and Suspension Components

Service Interval: Every 100 hours—Inspect the steering and suspension for loose or damaged components.

With the steering wheel at the centered position (Figure 44), turn the steering wheel to the left or right. If you turn the steering wheel more than 13 mm (1/2 inch) to the left or right, and the tires do not turn, check the following steering and suspension components to ensure that they are not loose or damaged:

- Steering shaft to the steering-rack assembly joint

Important: Inspect the condition and security of the pinion-shaft seal (Figure 45).

- Steering-rack assembly tie rods

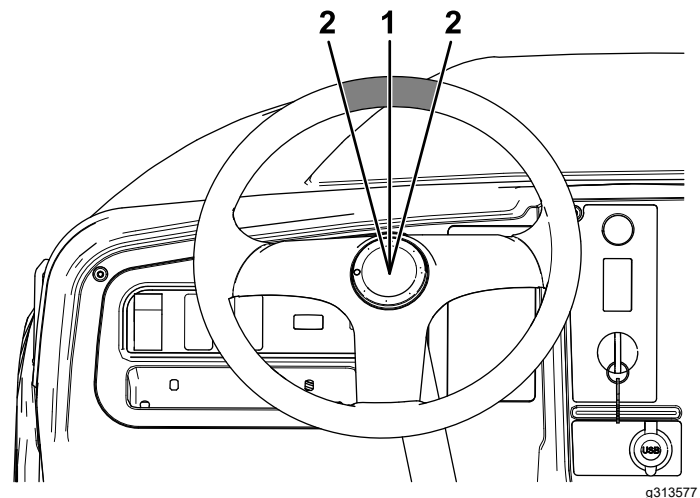

Figure 44

1. Steering wheel at the centered position
2. 13 mm (1/2 inch) from the center of the steering wheel

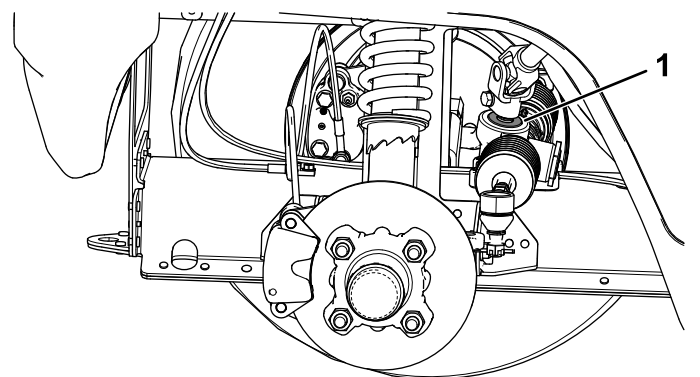

Figure 45

1. Pinion-shaft seal

Adjusting the Front Wheel Toe-in

Service Interval: Every 100 hours/Yearly (whichever comes first)—Check the front wheel toe-in.

Important: You need Toro Tool No. 6010 from your Toro Distributor to perform this procedure.

The toe-in should be 0 +/- 3 mm (0 +/- 1/8 inch).

- Check the tire pressure to ensure that the front tires are inflated to 165 to 207 kPa (24 to 30 psi).
- Either, add weight to the driver's seat equal to the average operator who will run the machine, or have an operator sit on the seat. The weight or operator must remain on the seat for the duration of the procedure.
- On a level surface, roll the machine straight back 2 to 3 m (6 to 10 ft) and then straight forward to the original starting position. This allows the suspension to settle into the operating position.
- Measure the toe-in with the wheels facing straight ahead.

Adjust the riding height to the desired position by performing the following procedure:

1. Using Toro Tool No. 6010, rotate the collar on the shock absorber to change the spring pre-load (Figure 46).

Note: This is easier to do if the front of the machine is jacked up so that the front wheels are off the ground.

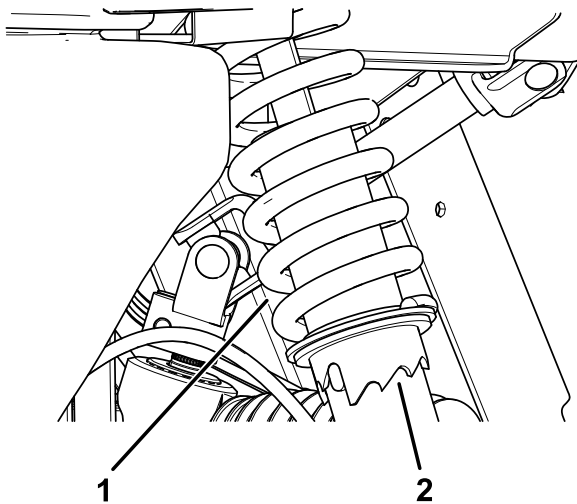

Figure 46

1. Shock-absorber spring
2. Collar

3. Measure the distance between both of the front tires at the axle height at both the front and rear of the front tires (Figure 47).

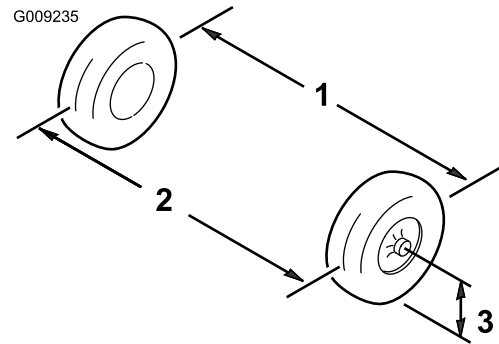

Figure 47

1. Tire center line—back
2. Tire center line—front
3. Axle center line

4. If the measurement does not fall within 0 +/- 3 mm (0 +/- 1/8 inch), loosen the jam nuts at the outer end of the tie rods (Figure 48).

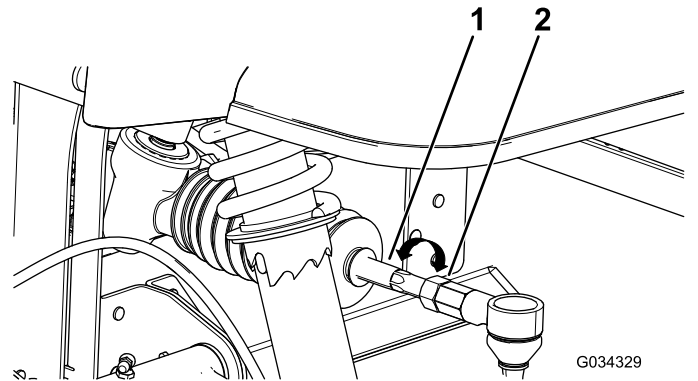

Figure 48

1. Tie rod
2. Jam nut

5. Rotate both tie rods to move the front of the tire inward or outward.
6. Tighten the tie rod jam nuts when the adjustment is correct.
7. Ensure that there is full travel of the steering wheel in both directions.

2. On a level surface, roll the machine straight back 2 to 3 m (6 to 10 ft) and then straight forward to the original starting position.

Changing the Transaxle Fluid

Service Interval: Every 100 hours

Every 800 hours/Yearly (whichever comes first)

Fluid Type: SAE 10W-30 (API service SJ or higher)

Fluid Capacity: 1.4 L (1.5 US qt)

1. Align a drain pan under the drain plug ([Figure 49](#)).

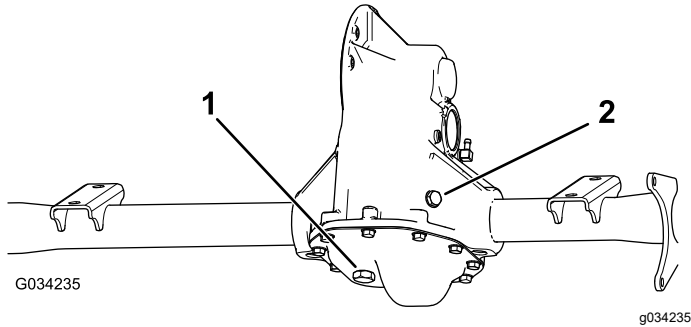

Figure 49

1. Drain plug

2. Fill plug

2. Remove the fill plug and the seal ([Figure 49](#)).

Note: Retain the fill plug and seal for installation in step 6.

3. Remove the drain plug and the seal, and allow the fluid to drain completely ([Figure 49](#)).

Note: Retain the drain plug and seal for installation in step 4.

4. Install the drain plug and seal, and torque it to 20 to 27 N·m (15 to 20 ft-lb).
5. Fill the transaxle with the specified fluid until it runs out of the fill hole.
6. Install the fill plug and seal, and torque it to 20 to 27 N·m (15 to 20 ft-lb).

Brake Maintenance

Checking the Parking Brake

1. Engage the parking brake by pulling the parking-brake lever toward you, until you feel tension.
2. If you do not feel tension when pulling the parking-brake toward you within 11.4 to 16.5 cm (4-1/2 to 6-1/2 inches) from the “P” symbol on the dash, then you need to adjust the parking brake; refer to [Adjusting the Parking Brake](#) ([page 43](#)).

Adjusting the Parking Brake

1. Ensure that the parking brake is disengaged.
2. Using jack stands, lift the rear of the machine; refer to [Lifting the Machine](#) ([page 29](#)).
3. Using 2 wrenches, hold the adjusting post on the caliper in place with 1 wrench, and loosen the jam nut 1/4 turn with the other wrench ([Figure 50](#)).

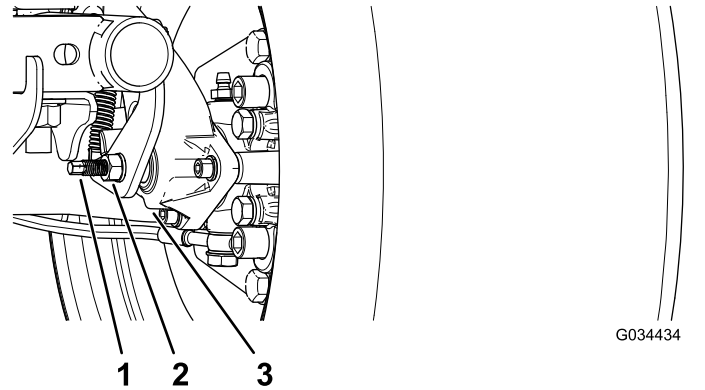

Figure 50

1. Adjusting post

3. Caliper

2. Jam nut

4. While holding the adjusting post and the jam nut in place, turn the adjusting post in to tighten ([Figure 50](#)).

Note: Perform this step until you feel drag on the wheel.

5. While holding the adjusting post and the jam nut in place, back off 1/4 turn ([Figure 50](#)).
6. While holding the adjusting post and the jam nut in place, tighten the jam nut ([Figure 50](#)).
7. Perform steps 1 through 6 to the other side.

- Verify that the parking brake is adjusted to the proper tension; refer to [Checking the Parking Brake \(page 43\)](#).

Note: If you cannot adjust the parking brake to the required tension, the brake pads may be worn and need to be replaced. Contact your Authorized Toro Service Dealer for assistance.

Checking the Brake-Fluid Level

Service Interval: Before each use or daily Check the brake-fluid level before the motor is first used.

Brake Fluid Type: DOT 3

- Park the machine on a level surface, engage the parking brake, shut off the machine, and remove the key.
- Raise the hood to gain access to the master-brake cylinder and reservoir ([Figure 51](#)).

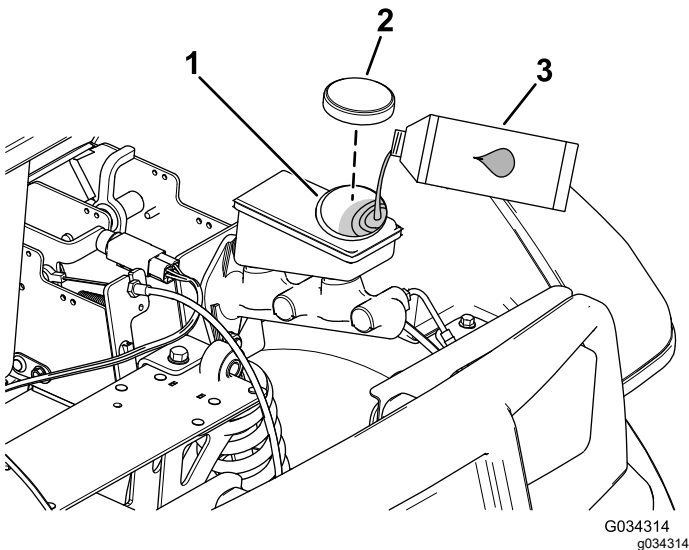

Figure 51

- Filler neck (reservoir)
- Reservoir cap
- DOT 3 brake fluid

- Look at the outline of the fluid level at the side of the reservoir ([Figure 52](#)).

Note: The level should be above the Minimum line.

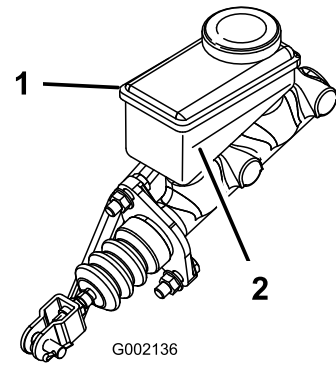

Figure 52

- Brake-fluid reservoir
- Minimum line

- If the fluid level is low, perform the following:
 - Clean the area around the reservoir cap and remove the cap ([Figure 51](#)).
 - Add DOT 3 brake fluid to the reservoir until the fluid level is above the Minimum line ([Figure 52](#)).

Note: Do not overfill the reservoir with brake fluid.
 - Install the reservoir cap ([Figure 51](#)).
- Close the hood of the machine.

Inspecting the Brakes

Service Interval: Every 100 hours

Brakes are a critical safety component of the machine. As with all safety components, they should be closely inspected at regular intervals to ensure optimum performance and safety.

- Inspect the brake shoes for wear or damage. If the lining (brake pad) thickness is less than 1.6 mm (1/16 inch), the brake shoes should be replaced.
- Inspect the backing plate and other components for signs of excessive wear or deformation. If any deformation is found, the appropriate components must be replaced.
- Check the brake-fluid level; refer to [Checking the Brake-Fluid Level \(page 44\)](#).

Replacing the Service and Parking-Brake Pads

Service Interval: Every 400 hours

Contact your authorized Authorized Toro Service Dealer to inspect and possibly replace the service and parking-brake pads.

Changing the Brake Fluid

Service Interval: Every 1,000 hours

Contact your authorized Authorized Toro Service Dealer.

Chassis Maintenance

Adjusting the Cargo-Box Latches

If the cargo-box latch is out of adjustment, the cargo box vibrates up and down as you drive the machine. You can adjust the latch posts to make the latches hold the cargo box snugly to the chassis.

1. Verify that the cargo box is latching.

Note: If the cargo box does not latch, the box-latch striker is likely too low. If the cargo box latches, but vibrates up and down as you drive, the box-latch striker is likely too high.

2. Raise the cargo box; [Raising the Cargo Box to the Dump Position \(page 19\)](#).
3. Loosen the 2 bolts on the box-latch striker and move the striker up or down, depending on if the striker is too high or too low ([Figure 53](#)).

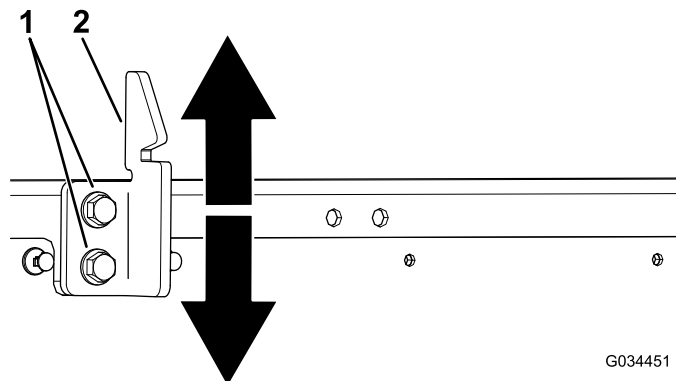

G034451

g034451

Figure 53

1. Bolts
2. Box-latch striker

4. Tighten the 2 bolts on the box-latch striker ([Figure 53](#)).
5. Verify that the adjustment is correct by latching the cargo box several times.

Cleaning

Washing the Machine

Wash the machine as needed. Use water alone or with a mild detergent. You may use a rag when washing the machine; however, the hood will lose some of its luster.

Important: Pressurized water is not recommended when washing the machine. It may damage the electrical system, loosen important decals, or wash away necessary grease at friction points. Avoid excessive use of water, especially near the control panel, motor, motor controller, charger, back of the dashboard, and batteries.

Storage

1. Park the machine on a level surface, engage the parking brake, shut off the machine, and remove the key.
2. Clean dirt and grime from the entire machine, including the outside of the motor housing.

Important: You can wash the machine with mild detergent and water. Do not use high pressure water to wash the machine. Pressure washing may damage the electrical system or wash away necessary grease at friction points. Avoid excessive use of water, especially near the control panel, lights, motor, and the battery.

3. Inspect the brakes; refer to [Inspecting the Brakes \(page 44\)](#).
4. Grease the machine; refer to [Greasing the Machine \(page 31\)](#).
5. Check the tire pressure; refer to [Checking the Tire Pressure \(page 22\)](#).
6. Check and tighten all bolts, nuts, and screws. Repair or replace any part that is damaged.
7. Paint all scratched or bare metal surfaces.

Note: Paint is available from your Authorized Service Dealer.

8. Store the machine in a clean, dry garage or storage area.
9. Remove the key and put it in a safe place out of the reach of children.
10. Cover the machine to protect it and keep it clean.

3. After fully charging the batteries, fill the batteries with distilled or deionized water before storing; refer to [Adding Distilled or Deionized Water to the Batteries \(page 37\)](#).

Battery Storage

1. Charge the batteries fully before placing the machine into storage; refer to [Charging the Batteries \(page 35\)](#). Plug the charger into a wall outlet while the machine and batteries are in storage. Leave the charger plugged into a wall outlet and charging receptacle during storage to ensure that the batteries stay charged and do not freeze; otherwise, charge the batteries monthly at a minimum.
2. Plug in the charger during storage to maintain full battery life.

Important: If the machine cannot be plugged in during storage, fully charge the batteries at least once a month. The batteries self-discharge over long periods of time, which may damage the batteries to the point of being unusable, even if the batteries are new.

Troubleshooting

Machine-Status Light Flash Pattern

Problem	Possible Cause	Corrective Action
The machine-status light is always illuminated.	1. The system is functioning properly.	1. None
The machine-status light flashed 1 time.	1. There is a controller-configuration fault.	1. Contact your Authorized Toro Service Dealer.
The machine-status light flashed 2 times.	1. The parking brake is engaged while in FORWARD or REVERSE position. 2. A drive-switch fault occurred.	1. Disengage the parking brake. 2. Turn off the machine and check the functionality of the switches.
The machine-status light flashed 3 times.	1. The motor current exceeded the controller-rated maximum. 2. There is an internal-power component fault.	1. Turn the key switch to the OFF position, wait a few seconds, and turn the key switch to the ON position. Check all batteries and high-current controller connections. If the condition continues, refer to your Authorized Service Dealer. 2. Contact your Authorized Toro Service Dealer.
The machine-status light flashed 4 times.	1. A main-contactor fault occurred.	1. Test the contact wires, coil and contacts for normal operation.
The machine-status light flashed 5 times.	1. Exceeded the maximum motor speed.	1. Turn the key switch to the OFF position, wait a few seconds, turn the key switch to the ON position, and check for normal operation.
The machine-status light flashed 6 times.	1. The throttle is pressed while starting the machine. 2. There is a wire that is not making a connection.	1. Release the pedal, turn the key switch to the OFF position, wait a few seconds, turn the key switch to the ON position, and check for normal operation. 2. Test the wiring between the controller and contactor, switches, and the status-indicator light.
The machine-status light flashed 7 times.	1. The remaining charge on the batteries is low. 2. The batteries are fully discharged. 3. The internal capacitor has a pre-charge of less than 5V.	1. Stop operation, drive slowly to your nearest charging station, and charge the batteries fully. 2. Tow the machine to your charging station and charge the batteries fully. 3. Fully charge the batteries, turn the key switch to the OFF position, wait a few seconds, turn the key switch to the ON position, and check for normal operation.
The machine-status light flashed 8 times.	1. The controller or motor is overheated or too cold.	1. Determine if the motor or controller is very hot or very cold, then allow the machine to return to safe temperatures before resuming normal operation.
The machine-status light flashed 10 times.	1. A controller-configuration fault occurred.	1. Contact your Authorized Toro Service Dealer.

Problem	Possible Cause	Corrective Action
The machine-status light flashed 11 times.	<ol style="list-style-type: none"> 1. A motor-encoder fault occurred. 2. Exceeded the maximum motor speed. 	<ol style="list-style-type: none"> 1. Check the motor-encoder (speed sensor) wiring. 2. Turn the key switch to the OFF position, wait a few seconds, turn the key switch to the ON position, and check for normal operation.
The machine-status light flashed 12 times.	<ol style="list-style-type: none"> 1. A controller-configuration fault occurred. 	<ol style="list-style-type: none"> 1. Contact your Authorized Toro Service Dealer.
The machine-status light flashed 13 times.	<ol style="list-style-type: none"> 1. An internal-software fault occurred. 	<ol style="list-style-type: none"> 1. Contact your Authorized Toro Service Dealer.
The machine-status light flashed 14 times.	<ol style="list-style-type: none"> 1. A communication fault occurred. 	<ol style="list-style-type: none"> 1. Contact your Authorized Toro Service Dealer.
The machine-status light is not illuminated.	<ol style="list-style-type: none"> 1. There is either no power to the controller or the controller has failed. 	<ol style="list-style-type: none"> 1. Contact your Authorized Toro Service Dealer.

Notes:

European Privacy Notice

The Information Toro Collects

Toro Warranty Company (Toro) respects your privacy. In order to process your warranty claim and contact you in the event of a product recall, we ask you to share certain personal information with us, either directly or through your local Toro company or dealer.

The Toro warranty system is hosted on servers located within the United States where privacy law may not provide the same protection as applies in your country.

BY SHARING YOUR PERSONAL INFORMATION WITH US, YOU ARE CONSENTING TO THE PROCESSING OF YOUR PERSONAL INFORMATION AS DESCRIBED IN THIS PRIVACY NOTICE.

The Way Toro Uses Information

Toro may use your personal information to process warranty claims, to contact you in the event of a product recall and for any other purpose which we tell you about. Toro may share your information with Toro's affiliates, dealers or other business partners in connection with any of these activities. We will not sell your personal information to any other company. We reserve the right to disclose personal information in order to comply with applicable laws and with requests by the appropriate authorities, to operate our systems properly or for our own protection or that of other users.

Retention of your Personal Information

We will keep your personal information as long as we need it for the purposes for which it was originally collected or for other legitimate purposes (such as regulatory compliance), or as required by applicable law.

Toro's Commitment to Security of Your Personal Information

We take reasonable precautions in order to protect the security of your personal information. We also take steps to maintain the accuracy and current status of personal information.

Access and Correction of your Personal Information

If you would like to review or correct your personal information, please contact us by email at legal@toro.com.

Australian Consumer Law

Australian customers will find details relating to the Australian Consumer Law either inside the box or at your local Toro Dealer.



The Toro Warranty

A Limited Warranty

Electric
Workman

Conditions and Products Covered

The Toro Company and its affiliate, Toro Warranty Company, pursuant to an agreement between them, jointly warrant your Toro Commercial product ("Product") to be free from defects in materials or workmanship for two years or 1500 operational hours*, whichever occurs first. Where a warrantable condition exists, we will repair the Product at no cost to you including diagnostics, labor, parts, and transportation. This warranty begins on the date the Product is delivered to the original retail purchaser.

* Product equipped with an hour meter.

Instructions for Obtaining Warranty Service

You are responsible for notifying the Commercial Products Distributor or Authorized Commercial Products Dealer from whom you purchased the Product as soon as you believe a warrantable condition exists. If you need help locating a Commercial Products Distributor or Authorized Dealer, or if you have questions regarding your warranty rights or responsibilities, you may contact us at:

Commercial Products Service Department
Toro Warranty Company
8111 Lyndale Avenue South
Bloomington, MN 55420-1196
E-mail: commercial.warranty@toro.com

Owner Responsibilities

As the Product owner, you are responsible for required maintenance and adjustments stated in your *Operator's Manual*. Failure to perform required maintenance and adjustments can be grounds for disallowing a warranty claim.

Items and Conditions Not Covered

Not all product failures or malfunctions that occur during the warranty period are defects in materials or workmanship. This warranty does not cover the following:

- Product failures which result from the use of non-Toro replacement parts, or from installation and use of add-on, or modified non-Toro branded accessories and products. A separate warranty may be provided by the manufacturer of these items.
- Product failures which result from failure to perform recommended maintenance and/or adjustments. Failure to properly maintain your Toro product per the Recommended Maintenance listed in the *Operator's Manual* can result in claims for warranty being denied.
- Product failures which result from operating the Product in an abusive, negligent or reckless manner.

Countries Other than the United States or Canada

Customers who have purchased Toro products exported from the United States or Canada should contact their Toro Distributor (Dealer) to obtain guarantee policies for your country, province, or state. If for any reason you are dissatisfied with your Distributor's service or have difficulty obtaining guarantee information, contact the Toro importer. If all other remedies fail, you may contact us at Toro Warranty Company.

- Parts subject to consumption through use unless found to be defective. Examples of parts which are consumed, or used up, during normal Product operation include, but are not limited to, batteries, carbon brushes, brake components, tires, filters, belts, etc.
- Failures caused by outside influence. Items considered to be outside influence include, but are not limited to, weather, storage practices, contamination, use of unapproved lubricants, additives, chemicals, etc.
- Normal "wear and tear" items. Normal "wear and tear" includes, but is not limited to, damage to seats due to wear or abrasion, worn painted surfaces, scratched decals or windows, etc.

Parts

Parts scheduled for replacement as required maintenance are warranted for the period of time up to the scheduled replacement time for that part. Parts replaced under this warranty are covered for the duration of the original product warranty and become the property of Toro. Toro will make the final decision whether to repair any existing part or assembly or replace it. Toro may use remanufactured parts for warranty repairs.

Note Regarding Deep Cycle Battery Warranty:

Deep cycle batteries have a specified total number of kilowatt-hours they can deliver during their lifetime. Operating, recharging, and maintenance techniques can extend or reduce total battery life. As the batteries in this product are consumed, the amount of useful work between charging intervals will slowly decrease until the battery is completely worn out. Replacement of worn out batteries, due to normal consumption, is the responsibility of the product owner. Battery replacement may be required during the normal product warranty period at owner's expense.

General Conditions

Repair by an Authorized Toro Distributor or Dealer is your sole remedy under this warranty.

Neither The Toro Company nor Toro Warranty Company is liable for indirect, incidental or consequential damages in connection with the use of the Toro Products covered by this warranty, including any cost or expense of providing substitute equipment or service during reasonable periods of malfunction or non-use pending completion of repairs under this warranty.

All implied warranties of merchantability and fitness for use are limited to the duration of this express warranty. Some states do not allow exclusions of incidental or consequential damages, or limitations on how long an implied warranty lasts, so the above exclusions and limitations may not apply to you.

This warranty gives you specific legal rights, and you may also have other rights which vary from state to state.