

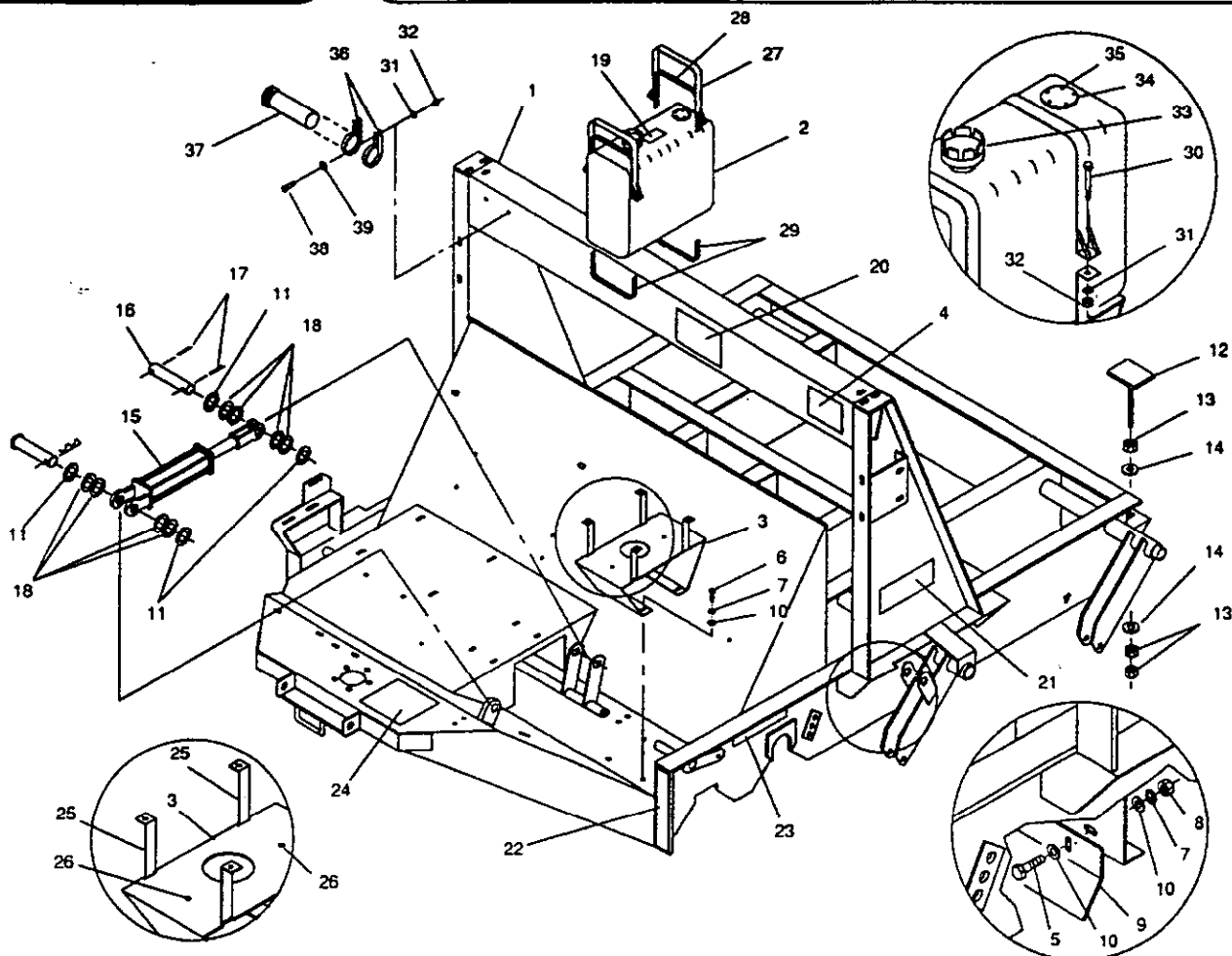

MODEL NO. 44089 - 30001 & UP

PARTS CATALOG

TURF SWEEPER 1655HL



MAIN FRAME ASSEMBLY

166HL-1

Ref. No.	Part No.	Description	No. Used
1	66-005-5414	Main Frame	1
2	53-9990	Gas Tank	1
*	66-004-4611	Fuel Line	1
*	01-280-0300	Gas Tank Gasket	1
3	66-004-4382	Gas Tank Stand	1
4	01-506-0070	Decal - Danger	1
5	323-7	Capscrew - Hex Hd.	4
6	323-6	Capscrew - Hex Hd.	4
7	3253-5	Lock Washer	8
8	3217-7	Hex Nut	4
9	66-004-1621	Air Deflector	1
10	3256-4	Flat Washer	12
11	01-168-1610	Machinery Bushing	4(var)
12	66-005-0421	Hopper Stop Pad	2
13	3217-11	Hex Nut	6

Ref. No.	Part No.	Description	No. Used
14	3256-7	Flat Washer	4
15	01-301-0060	Cylinder	1
*	01-301-0100	Seal Kit	1
16	66-004-2171	Cylinder Pin	1
17	3272-23	Cotter Pin	2
18	01-168-1614	Machinery Bushing	8(var)
19	01-506-0460	Decal - Gas	1
20	01-506-0520	Decal - Toro	1
21	01-506-0780	Decal - Turf Sweeper 1655HL	2
22	01-506-0150	Decal - Height Gauge	1
23	01-506-0080	Decal - Danger	1
24	01-506-1150	Decal - Danger	1
25	66-004-4371	Lower Tank Strap	2
26	01-161-0030	Pop Rivet	2
27	24-0620	Tank Strap	2

* Not Illustrated

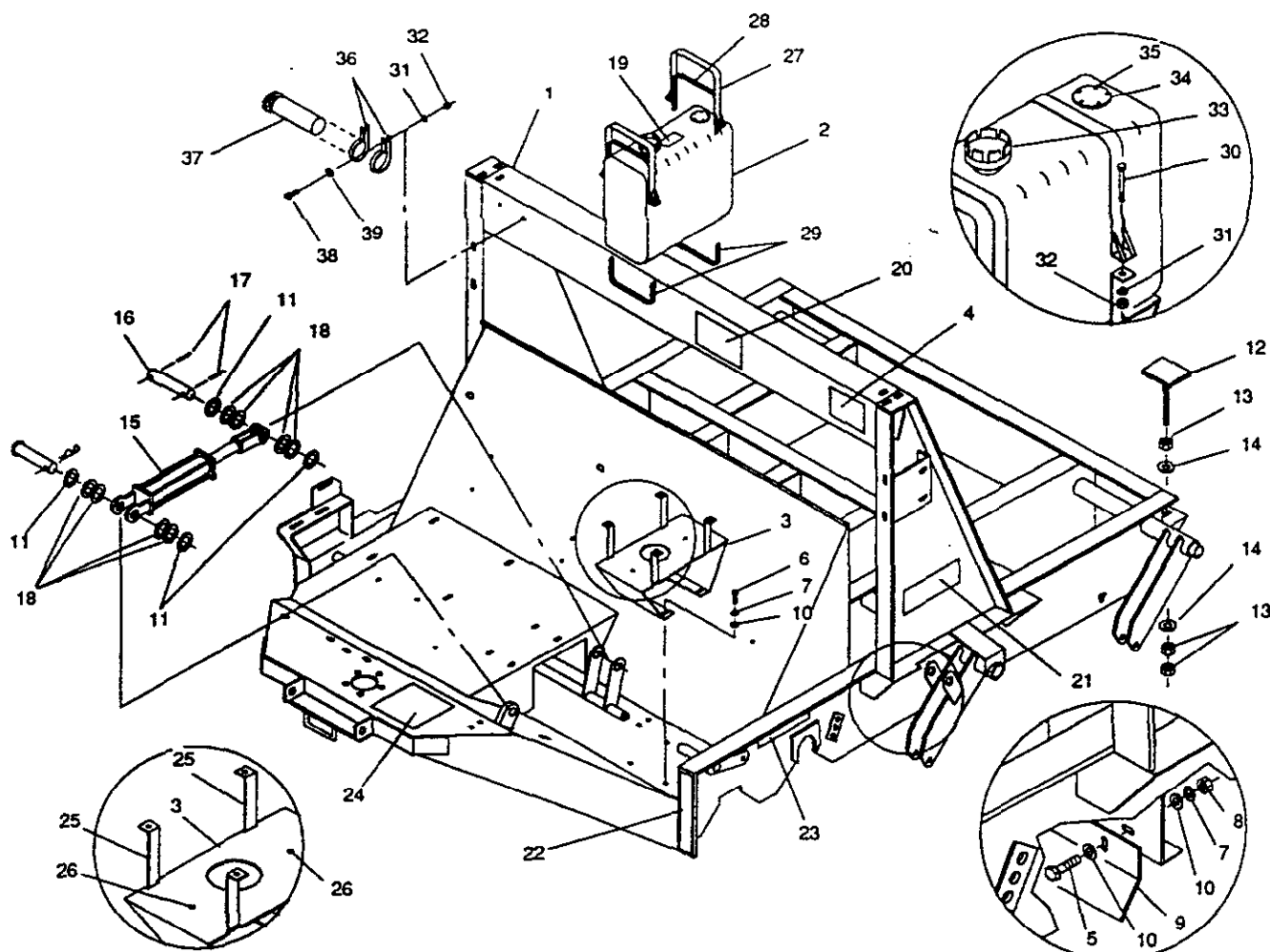

MAIN FRAME ASSEMBLY (Continued)

166HL-1

Ref. No.	Part No.	Description	No. Used
28	24-0610	Upper Felt Strip	2
29	25-8390	Lower Felt Strip	2
30	3258-37	Machine Screw - Slotted Rd. Hd.	4
31	3253-3	Lock Washer	6
32	3217-5	Hex Nut	6
33	01-280-0350	Cap & Gauge Unit	1

Ref. No.	Part No.	Description	No. Used
34	66-004-4341	Hole Cover	1
35	01-158-1690	Screw - Pan Hd.	5
36	2412-133	R-Clamp	2
37	74-0720	Tube	1
38	321-4	Capscrew - Hex Hd.	2
39	3256-2	Flat Washer	2

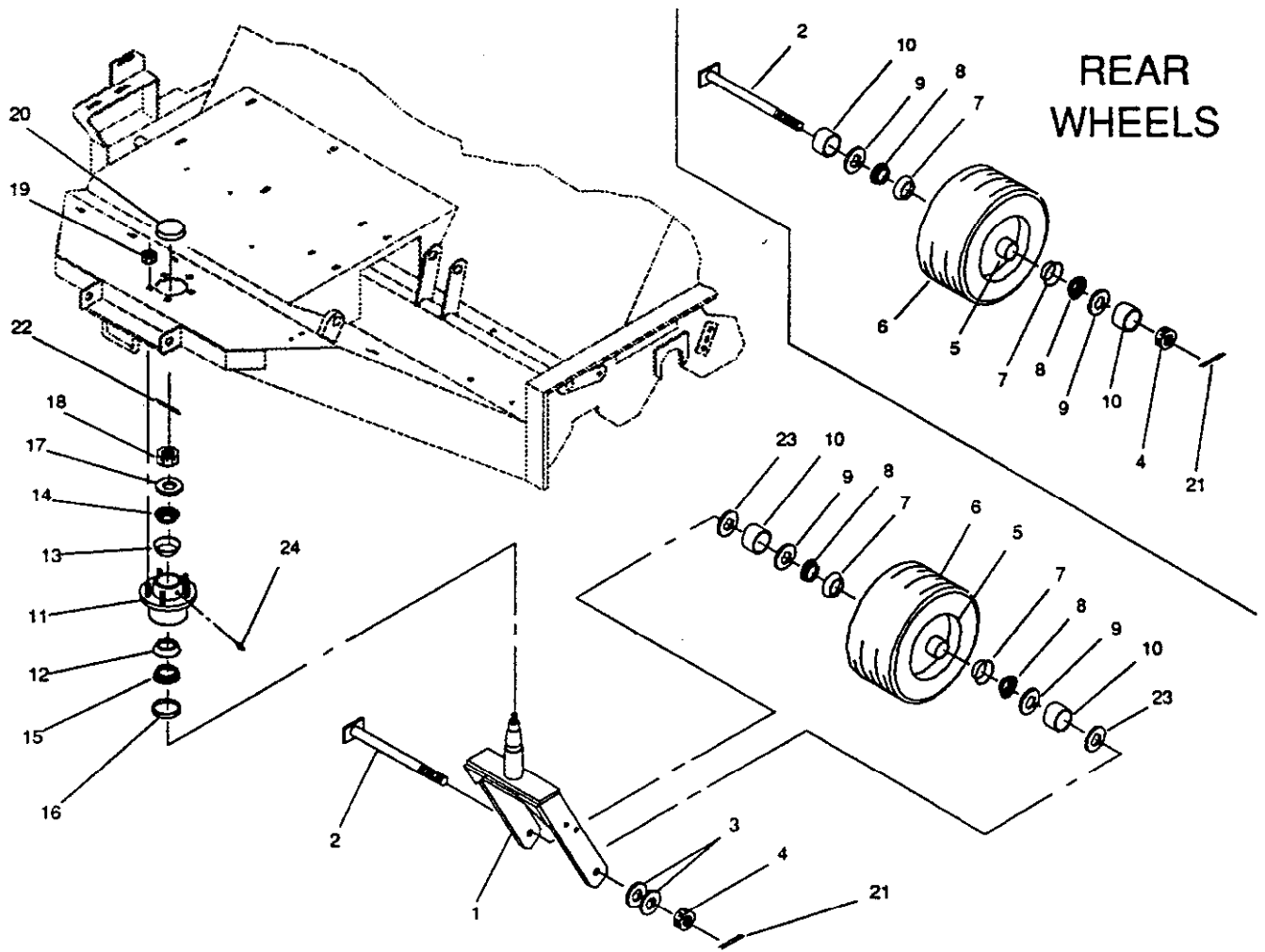

REAR
WHEELS

WHEEL ASSEMBLY

166HL-2

Ref. No.	Part No.	Description	No. Used
1	66-005-3481	Yoke Assembly	1
2	48-005-0421	Axle Bolt Assembly	5
3	01-168-1210	Machinery Bushing	2(var)
4	01-190-1210	Castle Nut	5
5	01-269-0340	Wheel	5
6	01-269-0320	Tire	5
7	01-103-0130	Race	10
8	01-102-0130	Bearing	10
9	01-405-0460	Oil Seal	10
10	01-269-0060	Wheel Spacer	10
11	01-269-2040	Steering Hub (Incl. Ref. #12,13)	1
12	01-103-0040	Inner Race	1
13	01-103-0140	Outer Race	1
14	01-102-0070	Outer Bearing	1

Ref. No.	Part No.	Description	No. Used
15	01-102-0050	Inner Bearing	1
16	01-405-0370	Seal	1
17	3256-28	"SAE" Flat Washer	1
18	01-190-1216	Castle Nut	1
19	01-269-0300	Lug Nut	5
20	01-286-0040	Dust Cap	1
21	3272-23	Cotter Pin	5
22	3272-15	Cotter Pin	1
23	01-168-1218	Machinery Bushing	2
24	01-215-0050	Grease Fitting	1
*	01-269-0140	Steering Hub, complete (Incl. Ref. #11,14,15,16,19,20)	1

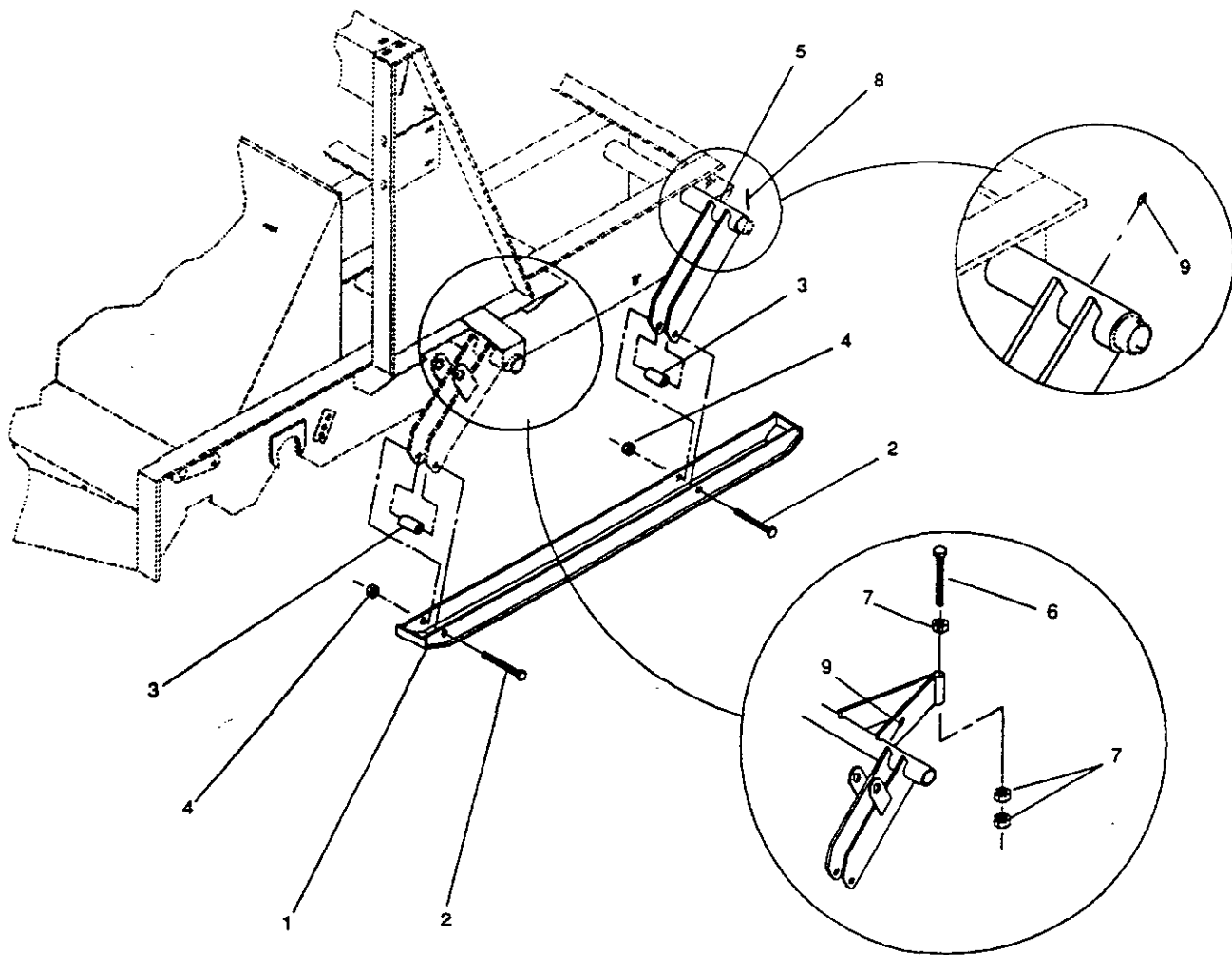

SKID ASSEMBLY

166HL-3

Ref. No.	Part No.	Description	No. Used
1	66-005-0381	Skid Assembly	2
2	327-16	Capscrew - Hex Hd.	4
3	66-004-2161	Spacer	4
4	3296-53	Lock Nut	4
5	66-005-0361	Rear Outrigger-L.H.	1

Ref. No.	Part No.	Description	No. Used
*	66-005-4221	Rear Outrigger-R.H.	1
6	01-182-1256	Capscrew - Hex Hd.	2
7	3217-12	Hex Nut	6
8	32121-10	Roll Pin	2
9	01-215-0050	Grease Fitting	4

* Not Illustrated

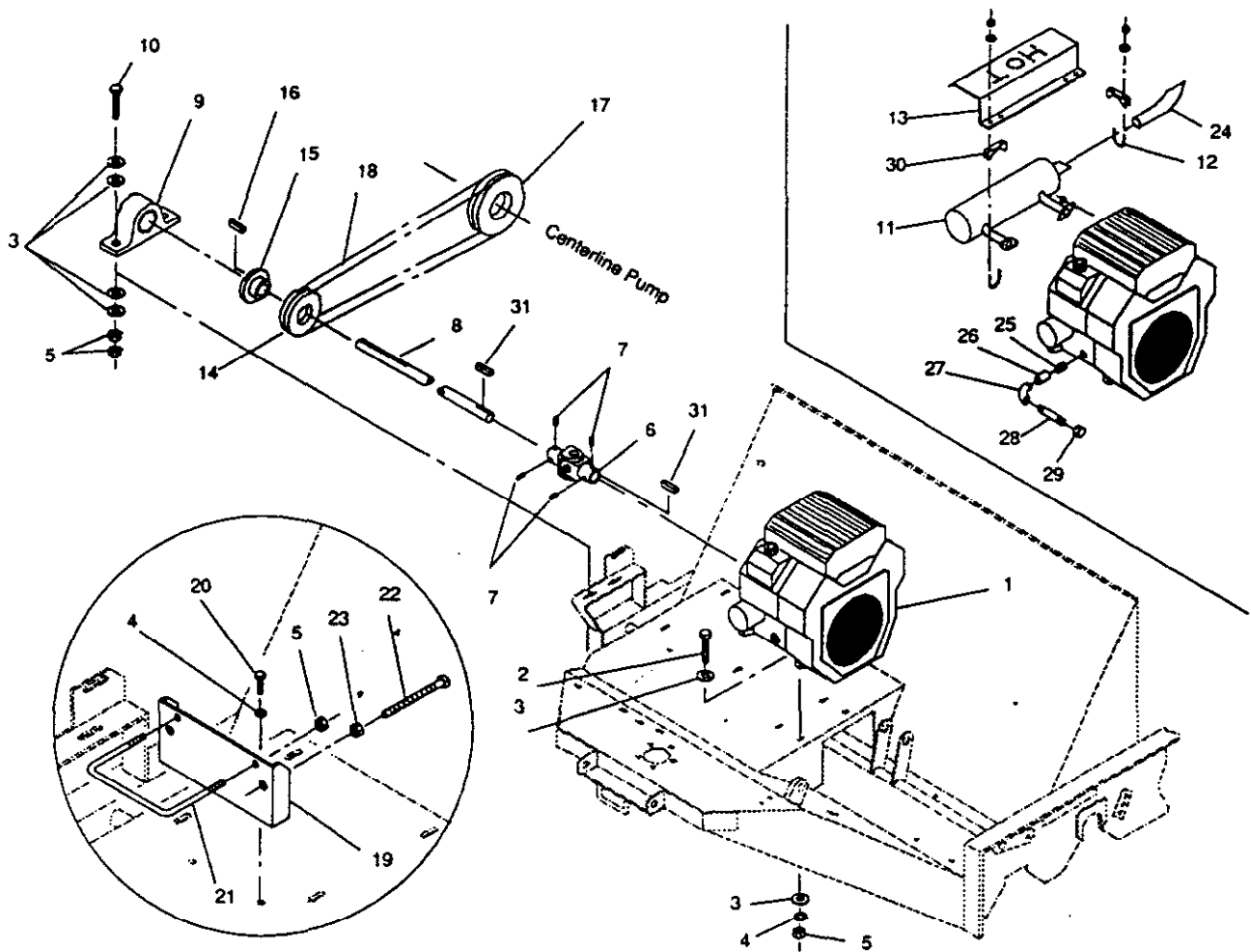

ENGINE MOUNTING

166HL-4

Ref. No.	Part No.	Description	No. Used
1	01-270-4130	Engine	1
*	01-270-4140	"Whisper Switch" Solenoid (Opt.)	1
*	01-600-0260	Battery Cable(neg)	1
*	01-600-0090	Battery Cable(pos)	1
2	323-9	Capscrew - Hex Hd.	4
3	3256-4	Flat Washer	16
4	3253-5	Lock Washer	6
5	3217-7	Hex Nut	10
6	01-263-0050	U-joint	1
7	01-163-0030	Set Screw	4
8	66-004-4361	Jack Shaft	1
9	01-113-0010	Bearing	1
10	323-10	Capscrew - Hex Hd.	2
11	01-273-0430	Muffler Kit	1
12	01-170-0160	Muffler Clamp	1
13	66-004-4491	Muffler Guard	1
14	01-260-0040	Sheave	1

Ref. No.	Part No.	Description	No. Used
15	01-260-0190	Bushing	1
16	48-004-1931	Key	1
17	01-260-0020	Sheave	1
18	01-264-0190	Belt	1
19	66-005-5431	Battery Bracket	1
20	323-6	Capscrew - Hex Hd.	2
21	48-004-3831	Battery Hold Down	1
22	01-182-0840	Capscrew - Hex Hd.	2
23	3217-9	Hex Nut	2
24	01-273-0310	Exhaust Extension	1
25	01-456-0050	Pipe Nipple	1
26	01-453-0130	Pipe Coupling	1
27	01-455-0200	Street Elbow	1
28	01-456-0130	Pipe Nipple	1
29	01-451-0120	Pipe Cap	1
30	01-170-0150	Muffler Clamp	2
31	82-004-1171	Key	2

* Not Illustrated

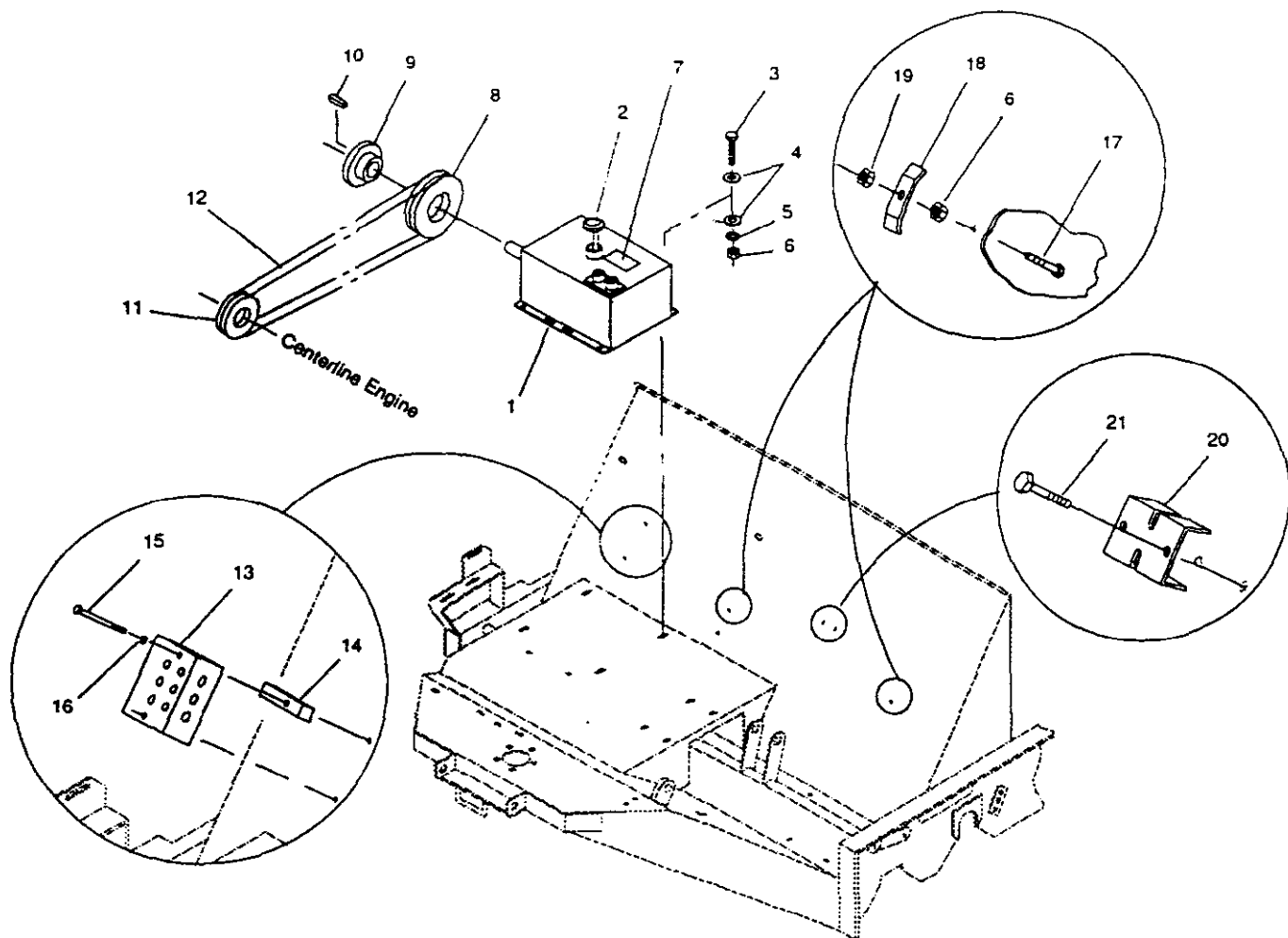

PUMP MOUNTING

166HL-5

Ref. No.	Part No.	Description	No. Used
1	01-305-0010	Pump	1
	01-305-0620	Seal Kit	1
2	41-002-0061	Dipstick	1
3	323-7	Capscrew - Hex Hd.	4
4	3256-4	Flat Washer	8
5	3253-5	Lock Washer	4
6	3217-7	Hex Nut	6
7	01-506-0560	Decal - Hydraulic Oil	1
8	01-260-0020	Sheave	1
9	01-260-0230	Bushing	1
10	84-004-2851	Key	1

Ref. No.	Part No.	Description	No. Used
11	01-260-0040	Sheave	1
12	01-264-0190	Belt	1
13	01-308-1040	Manifold Assembly	1
14	66-004-4531	Valve Spacer	2
15	321-20	Capscrew - Hex Hd.	2
16	3253-3	Lock Washer	2
17	323-9	Capscrew - Hex Hd.	2
18	48-004-3431	Hose Bracket	2
19	3296-22	Lock Nut	2
20	66-004-4841	Valve Clamp	1
21	323-10	Capscrew - Hex Hd.	2

* Not Illustrated

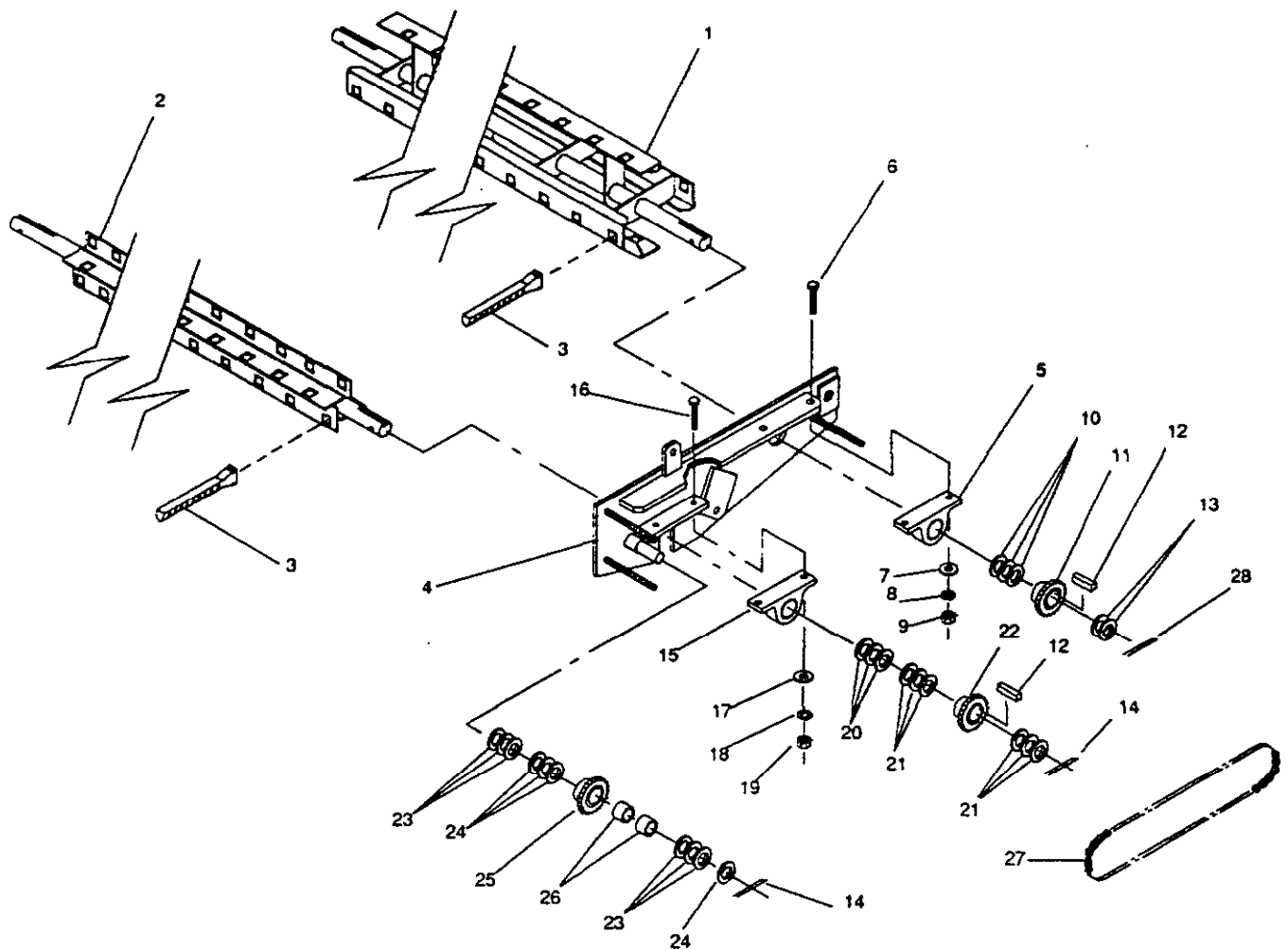

SWEEPER REEL & TIMING CHAIN ASSEMBLY

166HL-6

Ref. No.	Part No.	Description	No. Used
1	66-005-0242	Rear Reel Assembly	1
2	66-005-0231	Front Reel Assembly	1
3	01-279-0010	Rubber Fingers	140
4	48-005-0182	Reel Plate Assembly- L.H.	1
5	01-113-0020	Bearing	1
6	325-7	Capscrew - Hex Hd.	2
7	3256-6	Flat Washer	2
8	3253-7	Lock Washer	2
9	3217-9	Hex Nut	2
10	01-168-2014	Machinery Bushing	3(var)
11	01-262-0520	Sprocket	1
12	48-004-1931	Key	2
13	01-168-2010	Machinery Bushing	2
14	3272-23	Cotter Pin	2
15	01-113-0010	Bearing	1
16	323-8	Capscrew - Hex Hd.	1

Ref. No.	Part No.	Description	No. Used
17	3256-4	Flat Washer	1
18	3253-5	Lock Washer	1
19	3217-7	Hex Nut	1
20	01-168-1610	Machinery Bushing	3(var)
21	01-168-1614	Machinery Bushing	6(var)
22	01-262-0530	Sprocket	1
23	01-168-1410	Machinery Bushing	6(var)
24	01-168-1414	Machinery Bushing	4(var)
25	01-262-0610	Sprocket	1
26	01-105-0520	Needle Bearing	2
27	54-004-0941	Reel Chain	1
	01-251-0020	Offset Link	1
	48-002-5441	Idler Sprocket Assembly (Incl. Ref. #25, 26)	1
28	3272-25	Cotter Pin	1

* Not Illustrated

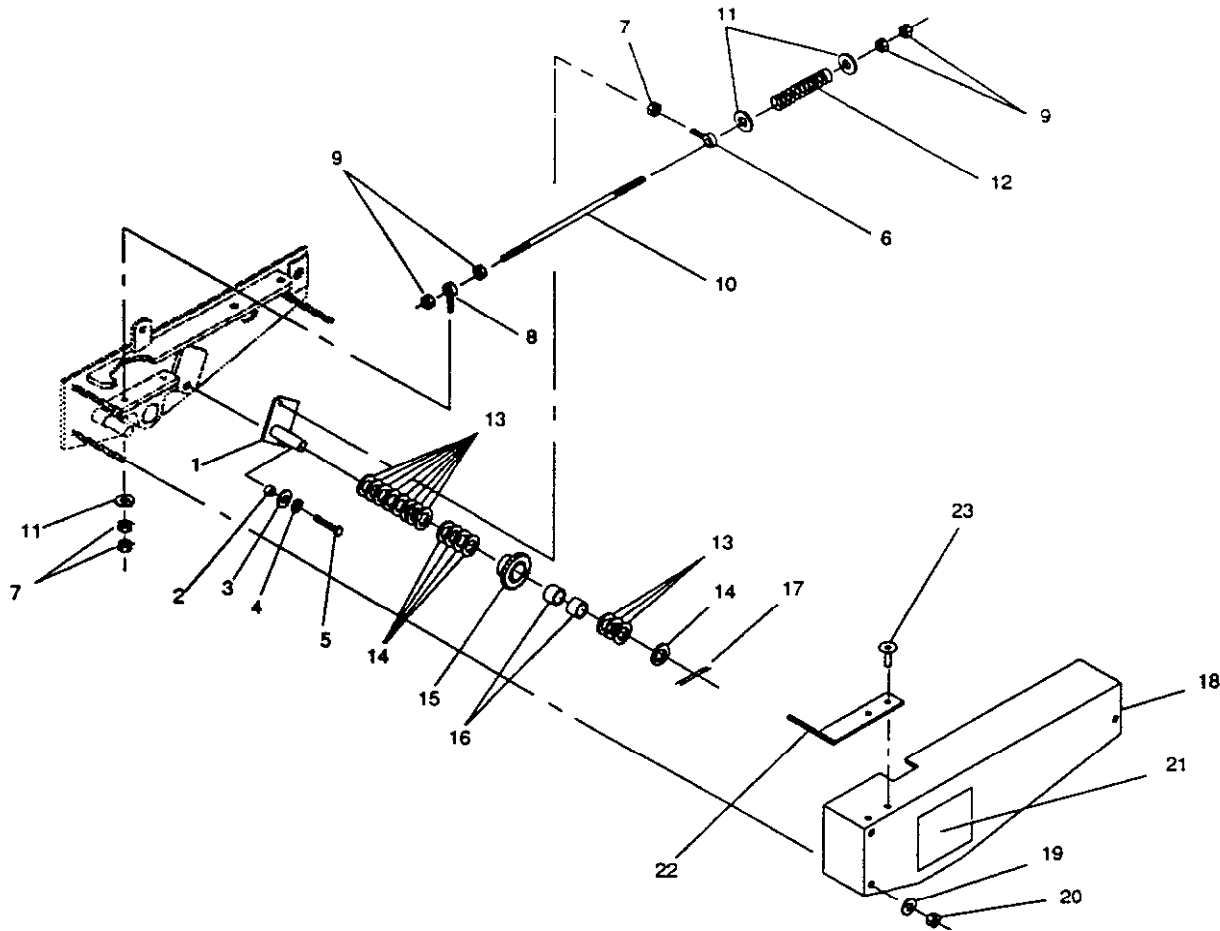

CHAIN IDLER & GUARD ASSEMBLY

166HL-7

Ref. No.	Part No.	Description	No. Used
1	48-005-0191	Idler Shaft Assembly	1
2	48-004-3881	Spacer	1
3	3256-26	"SAE" Flat Washer	1
4	3253-7	Lock Washer	1
5	325-5	Capscrew - Hex Hd.	1
6	02-250-0020	Rod End Bearing	1
7	3220-3	Jam Nut	3
8	01-250-0020	Rod End Bearing	1
9	3217-7	Hex Nut	4
10	48-004-3891	Idler Spring Rod	1
11	3256-4	Flat Washer	3
12	01-261-0300	Spring	1
13	01-168-1410	Machinery Bushing	11(var)

Ref. No.	Part No.	Description	No. Used
14	01-168-1414	Machinery Bushing	5(var)
15	01-262-0610	Sprocket	1
16	01-105-0520	Needle Bearing	2
17	3272-23	Cotter Pin	1
18	48-005-0162	Idler Cover	1
19	3256-5	Flat Washer	3
20	3296-48	Lock Nut	3
21	01-506-0050	Decal - Danger	1
*	48-002-5441	Idler Sprocket Assembly (Incl. Ref. # 15, 16)	1
22	66-005-0371	Reel Height Indicator	1
23	01-161-0030	Pop Rivet	2

* Not Illustrated

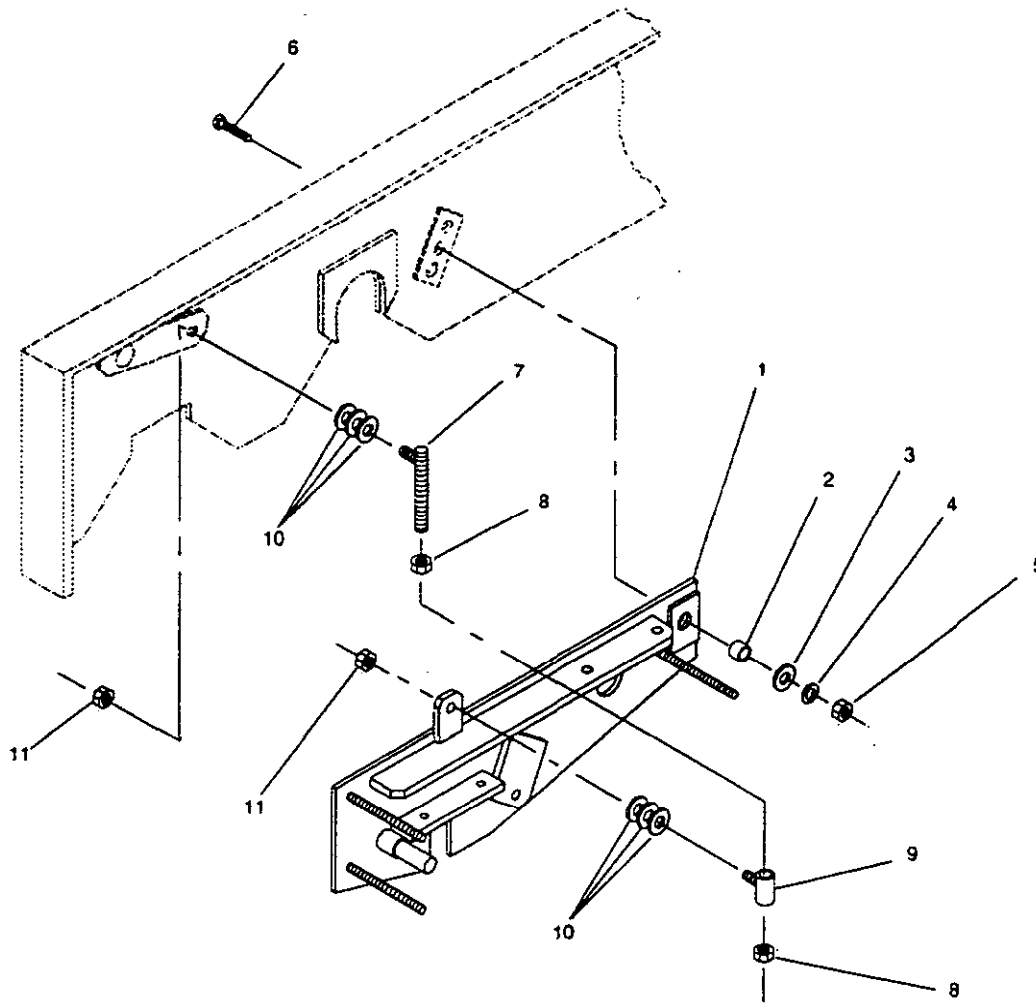

REEL LIFT ASSEMBLY - L.H.

166HL-8

Ref. No.	Part No.	Description	No. Used
1	48-005-0182	Reel Plate Assembly-L.H.	1
2	48-004-5841	Reel Plate Spacer	1
3	3256-27	*SAE* Flat Washer	1
4	3253-8	Lock Washer	1
5	3218-6	Jam Nut	1
6	327-6	Capscrew - Hex Hd.	1

Ref. No.	Part No.	Description	No. Used
7	66-005-0201	Reel Lift Rod Assembly	1
8	3217-11	Hex Nut	2
9	48-005-0591	Reel Lift Tube Assembly	1
10	3256-6	Flat Washer	6
11	3296-25	Lock Nut	2

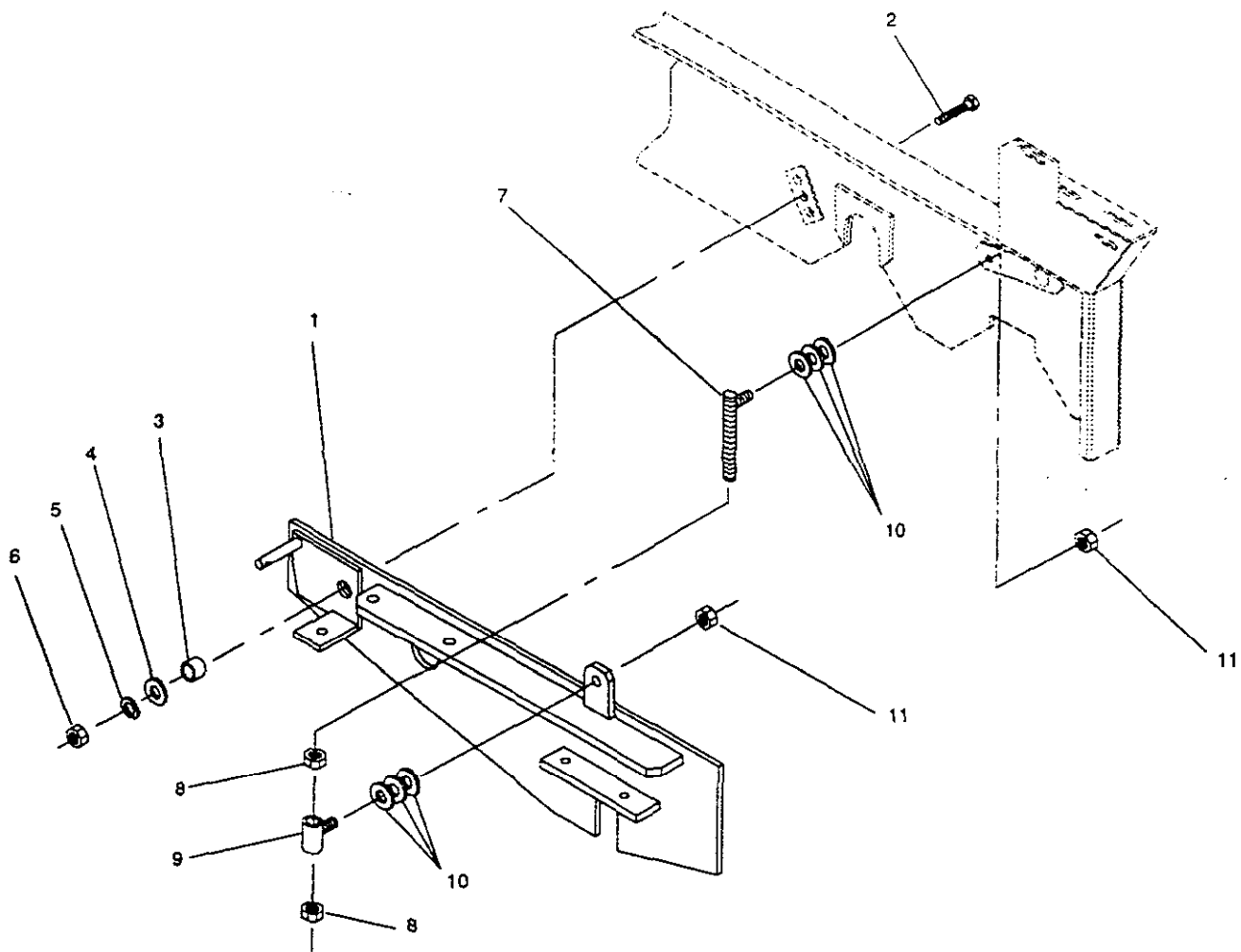

REEL LIFT ASSEMBLY - R.H.

166HL-9

Ref. No.	Part No.	Description	No. Used
1	48-005-0172	Reel Plate Assembly-R.H.	1
2	327-6	Capscrew - Hex Hd.	1
3	48-004-5841	Reel Plate Spacer	1
4	3256-27	"SAE" Flat Washer	1
5	3253-8	Lock Washer	1
6	3218-6	Jam Nut	1

Ref. No.	Part No.	Description	No. Used
7	66-005-0201	Reel Lift Rod Assembly	1
8	3217-11	Hex Nut	2
9	48-005-0591	Reel Lift Tube Assembly	1
10	3256-6	Flat Washer	6
11	3296-25	Lock Nut	2

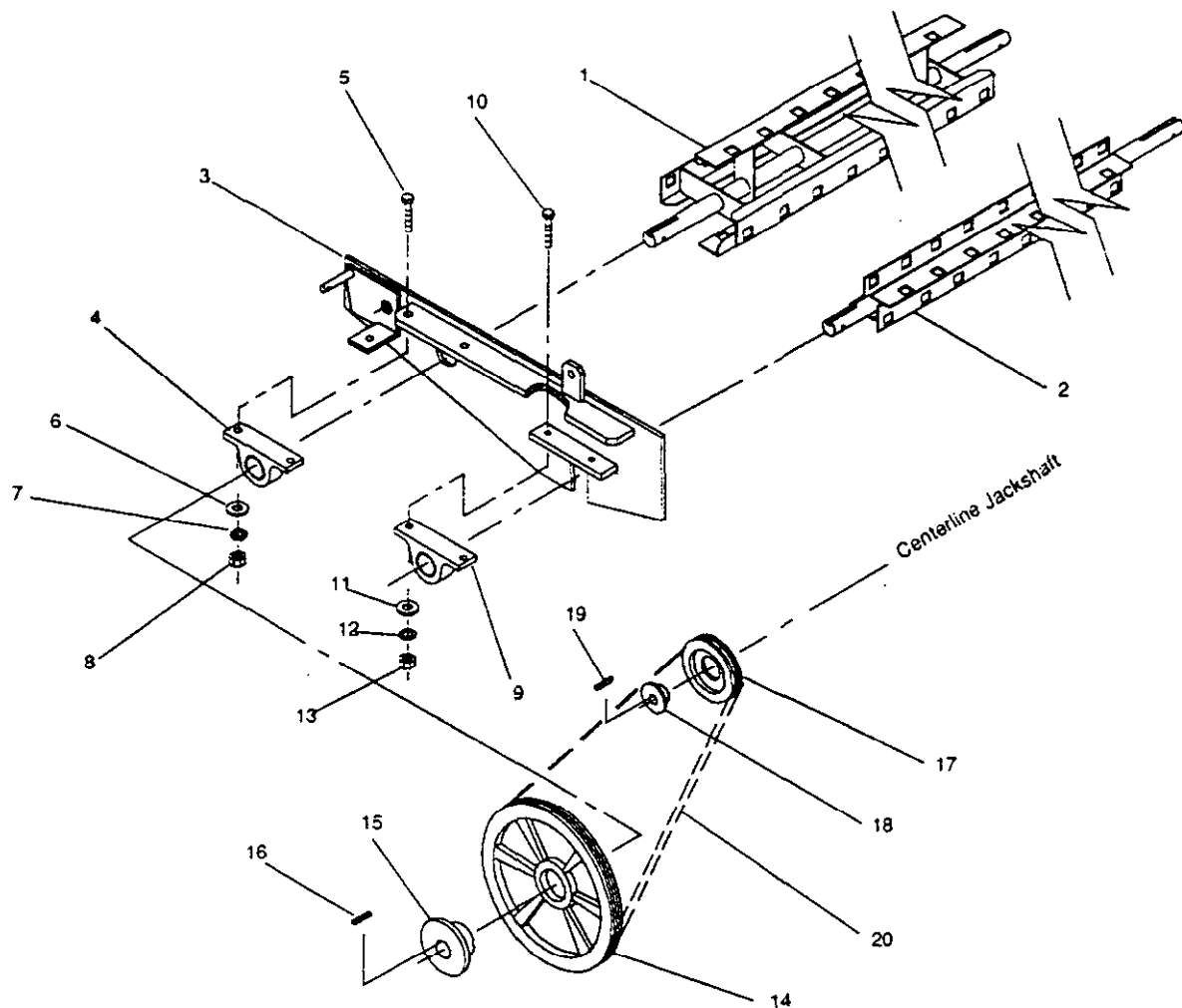

BELT DRIVE ASSEMBLY

166HL-10

Ref. No.	Part No.	Description	No. Used
1	66-005-0242	Rear Reel Assembly	1
2	66-005-0231	Front Reel Assembly	1
3	48-005-0172	Reel Plate Assembly-R.H.	1
4	01-113-0020	Bearing	1
5	325-7	Capscrew - Hex Hd.	2
6	3256-6	Flat Washer	2
7	3253-7	Lock Washer	2
8	3217-9	Hex Nut	2
9	01-113-0010	Bearing	1
10	323-8	Capscrew - Hex Hd.	2

Ref. No.	Part No.	Description	No. Used
11	3256-4	Flat Washer	2
12	3253-5	Lock Washer	2
13	3217-7	Hex Nut	2
14	01-260-0010	Sheave	1
15	01-260-0290	Bushing	1
16	66-004-3211	Key	1
17	01-260-0030	Sheave	1
18	01-260-0280	Bushing	1
19	82-004-1171	Key	1
20	01-264-0010	Belt	1

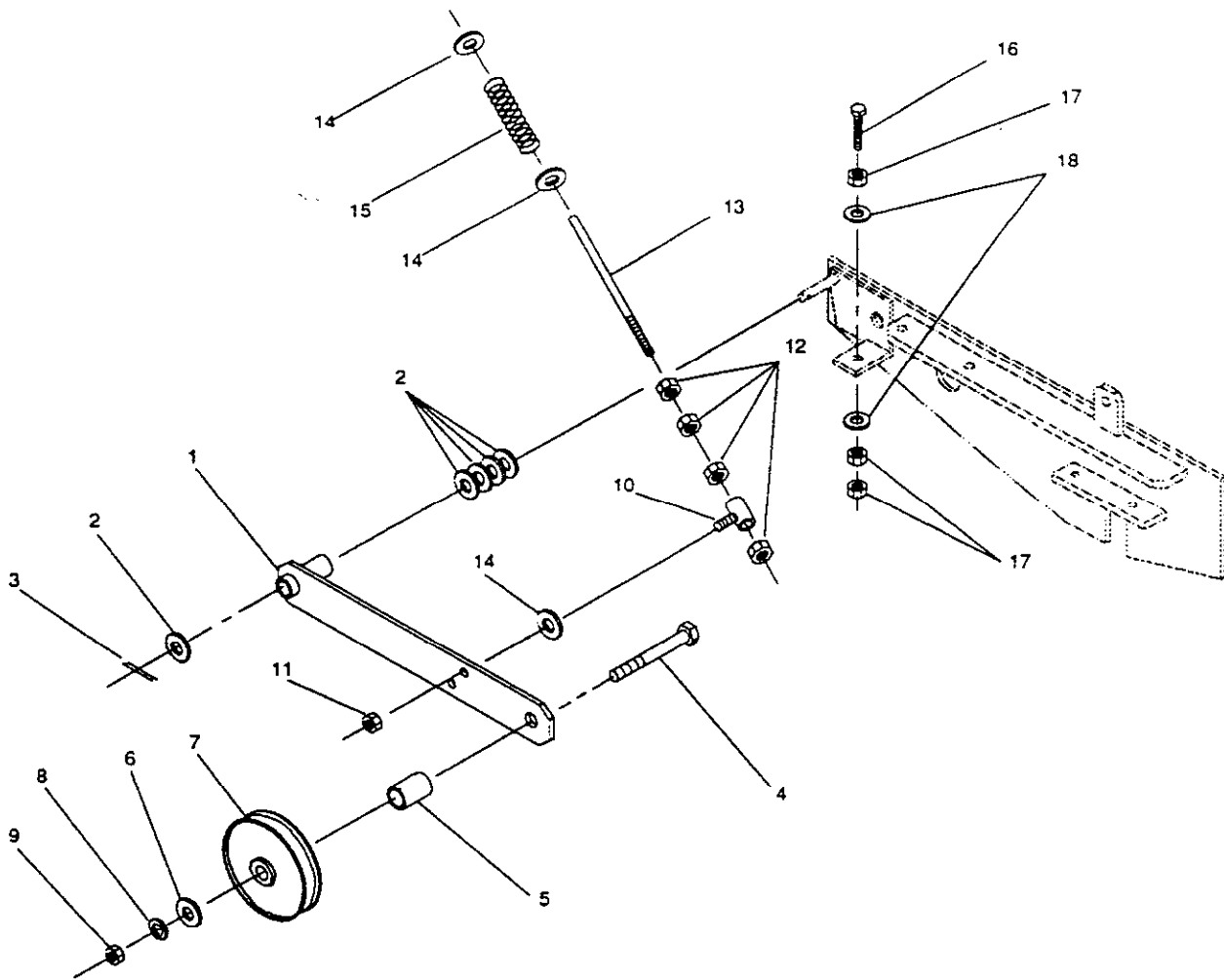

BELT IDLER ASSEMBLY

166HL-11

Ref. No.	Part No.	Description	No. Used
1	48-005-0611	Idler Arm	1
2	01-168-1014	Machinery Bushing	5
3	3272-21	Cotter Pin	1
4	327-14	Capscrew - Hex Hd.	1
5	48-004-3471	Spacer	1
6	3256-7	Flat Washer	2
7	01-268-0010	Pulley	1
8	3253-8	Lock Washer	1
9	3217-11	Hex Nut	1

Ref. No.	Part No.	Description	No. Used
10	48-005-0121	Spring Tension Adjustment	1
11	3296-22	Lock Nut	1
12	3217-7	Hex Nut	4
13	48-004-1711	Idler Spring Rod	1
14	3256-4	Flat Washer	3
15	01-261-0300	Spring	1
16	01-182-0832	Capscrew - Hex Hd.	1
17	3217-9	Hex Nut	3
18	3256-6	Flat Washer	2

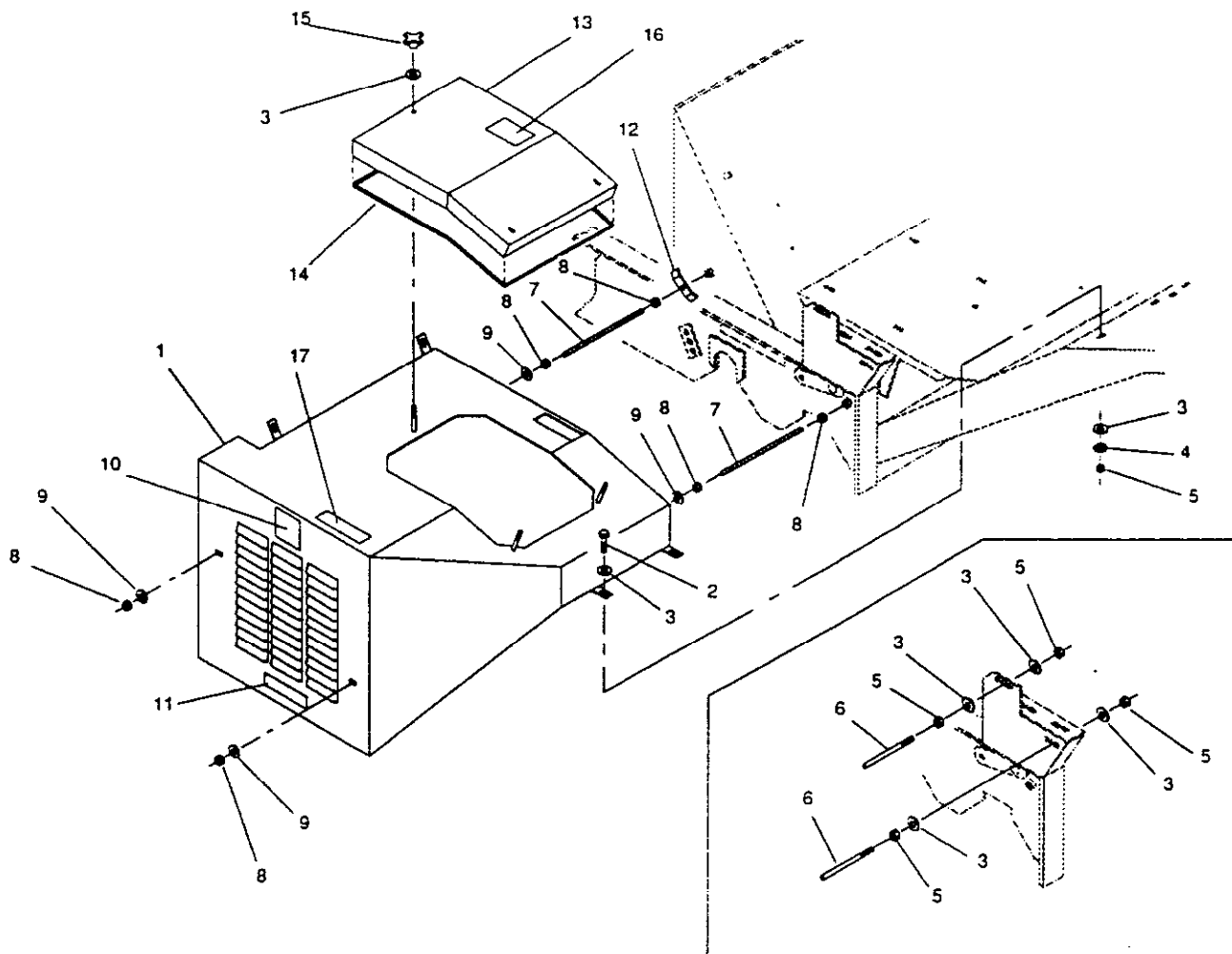

BELT GUARD & BELT SLIP PINS

166HL-12

Ref. No.	Part No.	Description	No. Used
1	66-005-5442	Belt Guard	1
2	323-6	Capscrew - Hex Hd.	4
3	3256-4	Flat Washer	15
4	3253-5	Lock Washer	4
5	3217-7	Hex Nut	8
6	48-004-1211	Belt Slip Pin	2
7	01-650-0400	All Thread	2
8	3217-8	Hex Nut	6
9	3256-5	Flat Washer	4

Ref. No.	Part No.	Description	No. Used
10	01-506-0040	Decal - Danger	1
11	01-506-0080	Decal - Danger	1
12	48-004-1861	Hose Bracket	1
13	66-005-5421	Access Cover	1
14	66-004-4571	Seal - Guard	1
15	01-257-0010	Knob	3
16	66-6840	Decal - Warning	1
17	75-5190	Decal - No Riders	1

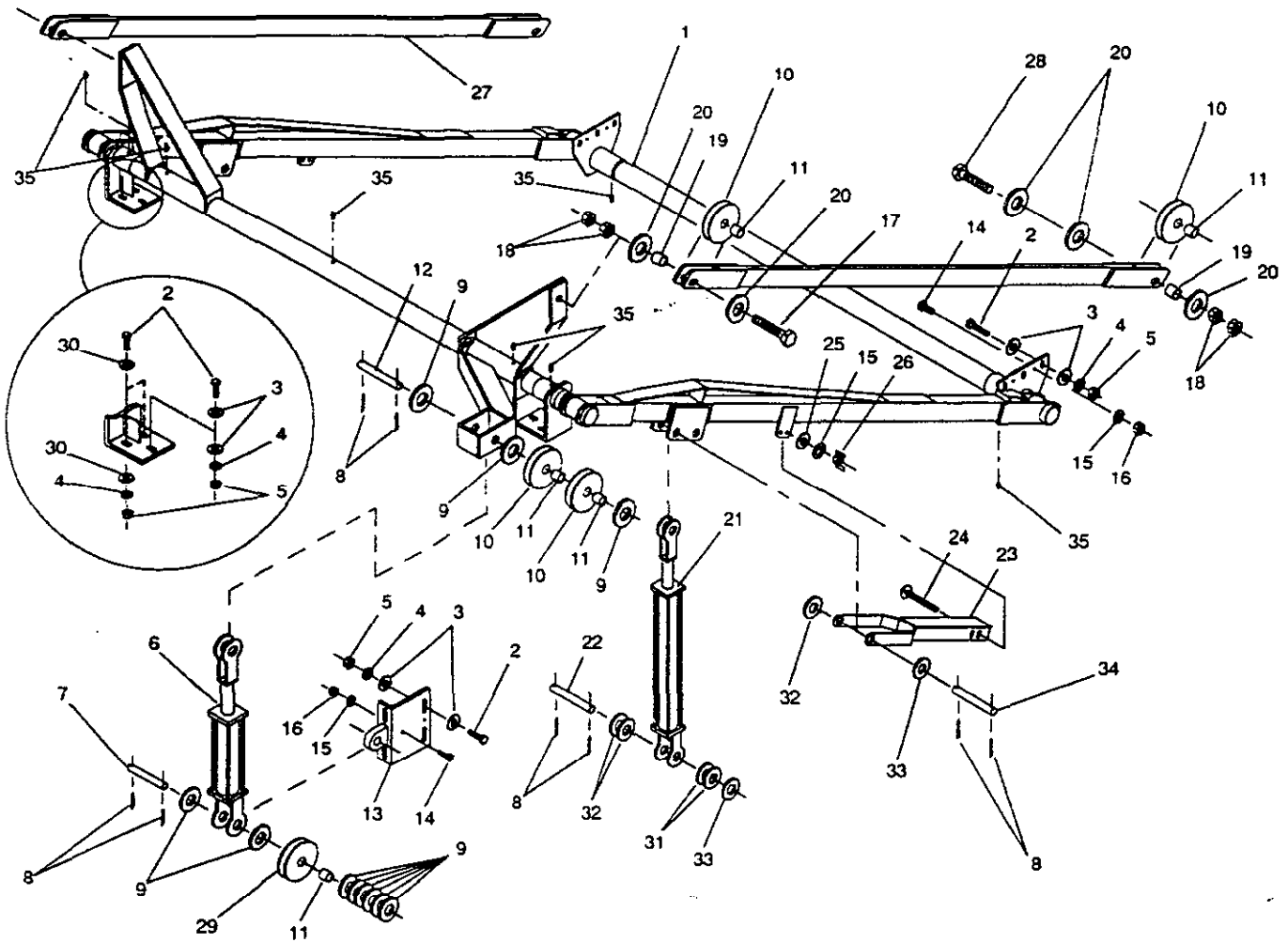

LIFT ARM ASSEMBLY

166HL-13

Ref. No.	Part No.	Description	No. Used
1	66-005-0192	Lift Arm Assembly	1
2	325-6	Capscrew - Hex Hd.	16
3	3256-6	Flat Washer	24
4	3253-7	Lock Washer	16
5	3217-9	Hex Nut	16
6	01-301-0060	Cylinder	1
*	01-301-0100	Seal Kit	1
7	66-004-4141	Cylinder Pin	1
8	3272-23	Cotter Pin	12
9	01-166-1600	Flat Washer	11(var)
10	01-268-0050	Cable Pulley	4
11	01-125-0030	Bronze Bushing	5
12	66-004-2181	Cylinder Pin	1
13	65-005-0281	Dump Cylinder Pivot Assembly	1
14	323-6	Capscrew - Hex Hd.	6
15	3253-5	Lock Washer	8
16	3217-7	Hex Nut	6
17	328-5	Capscrew - Hex Hd.	2
18	3218-7	Jam Nut	8

Ref. No.	Part No.	Description	No. Used
19	66-004-2141	Hopper Pivot Arm Bushing	4
20	01-166-1200	Flat Washer	10
21	01-301-0080	Cylinder	2
*	01-301-0100	Seal Kit	1
22	66-004-2171	Cylinder Pin	2
23	66-005-0271	Safety Stop	2
24	3231-10	Carriage Bolt	2
25	3256-4	Flat Washer	2
26	01-192-0070	Wing Nut	2
27	66-005-0251	Upper Arm Assembly	2
28	328-8	Capscrew - Hex Hd.	2
29	01-268-0040	Cable Pulley	1
30	3256-26	"SAE" Flat Washer	8
31	01-168-1610	Machinery Bushing	8(var)
32	01-168-1614	Machinery Bushing	8(var)
33	01-168-1618	Machinery Bushing	8(var)
34	66-004-3291	Cylinder Pin	2
35	01-215-0050	Grease Fitting	7

* Not Illustrated

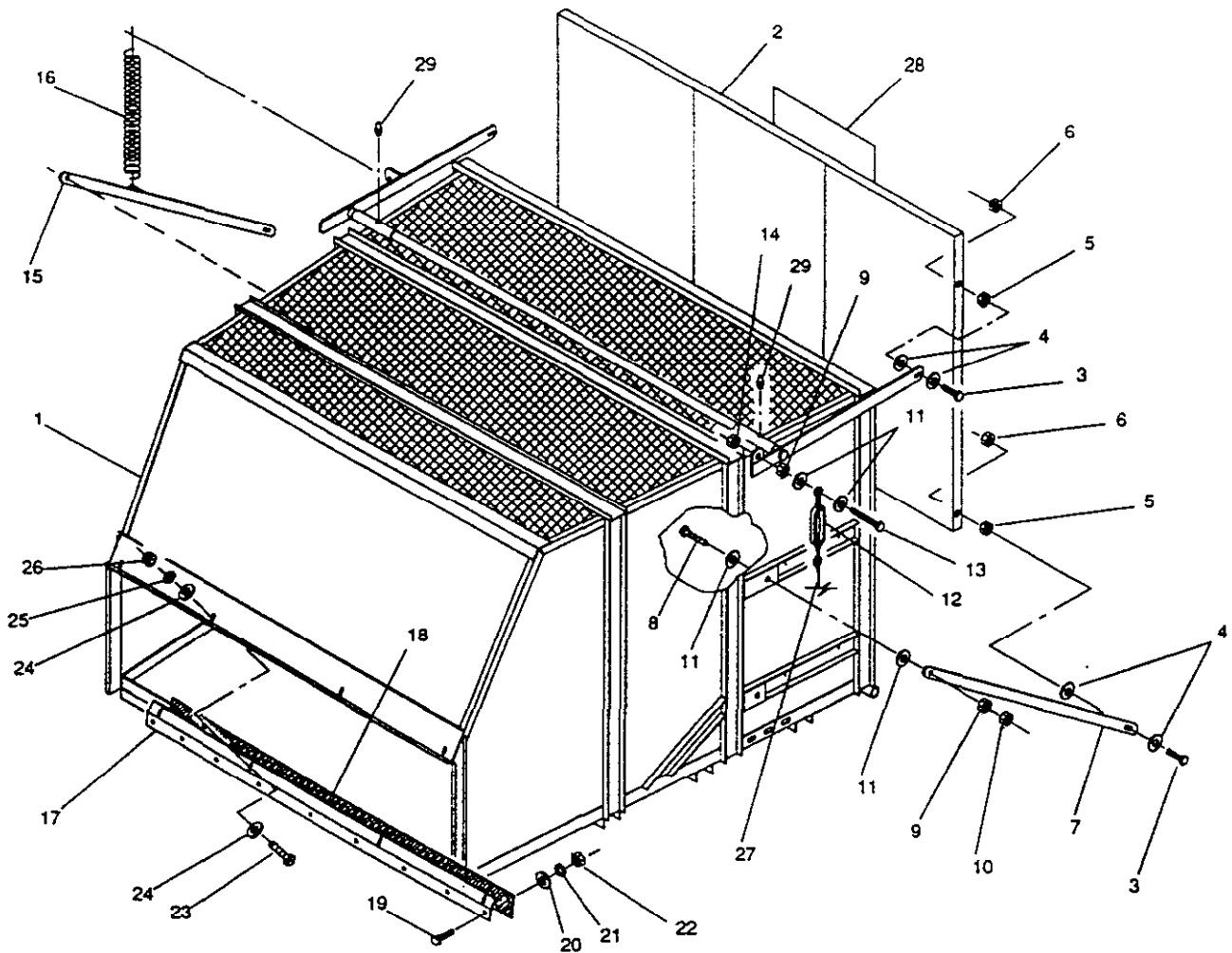

HOPPER ASSEMBLY

166HL-14

Ref. No.	Part No.	Description	No. Used
1	66-002-0442	Hopper Assembly	1
2	66-002-0042	Hopper Door Assembly	1
3	325-7	Capscrew - Hex Hd.	4
4	3256-6	Flat Washer	8
5	3217-9	Hex Nut	5
6	3296-25	Lock Nut	4
7	66-004-1641	Lower Door Arm-L.H.	1
8	327-9	Capscrew - Hex Hd.	2
9	3217-11	Hex Nut	3
10	3218-6	Jam Nut	2
11	3256-7	Flat Washer	6
12	01-171-0010	Turnbuckle	1
13	327-7	Capscrew - Hex Hd.	1
14	3296-53	Lock Nut	1
15	66-005-0211	Lower Door Arm-R.H.	1

Ref. No.	Part No.	Description	No. Used
16	66-004-3571	Door Spring	1
17	66-004-4182	Front Rubber Mount	1
18	66-004-4191	Rubber Flap	1
19	322-5	Capscrew - Hex Hd.	9
20	3256-3	Flat Washer	9
21	3253-4	Lock Washer	9
22	3217-6	Hex Nut	9
23	323-6	Capscrew - Hex Hd.	4
24	3256-4	Flat Washer	8
25	3253-5	Lock Washer	4
26	3217-7	Hex Nut	4
27	66-004-3361	Rear Door Lift Cable	1
*	01-170-0010	Cable Clamp	4
28	01-506-0530	Decal - Toro	1
29	01-215-0050	Grease Fitting	2

* Not Illustrated

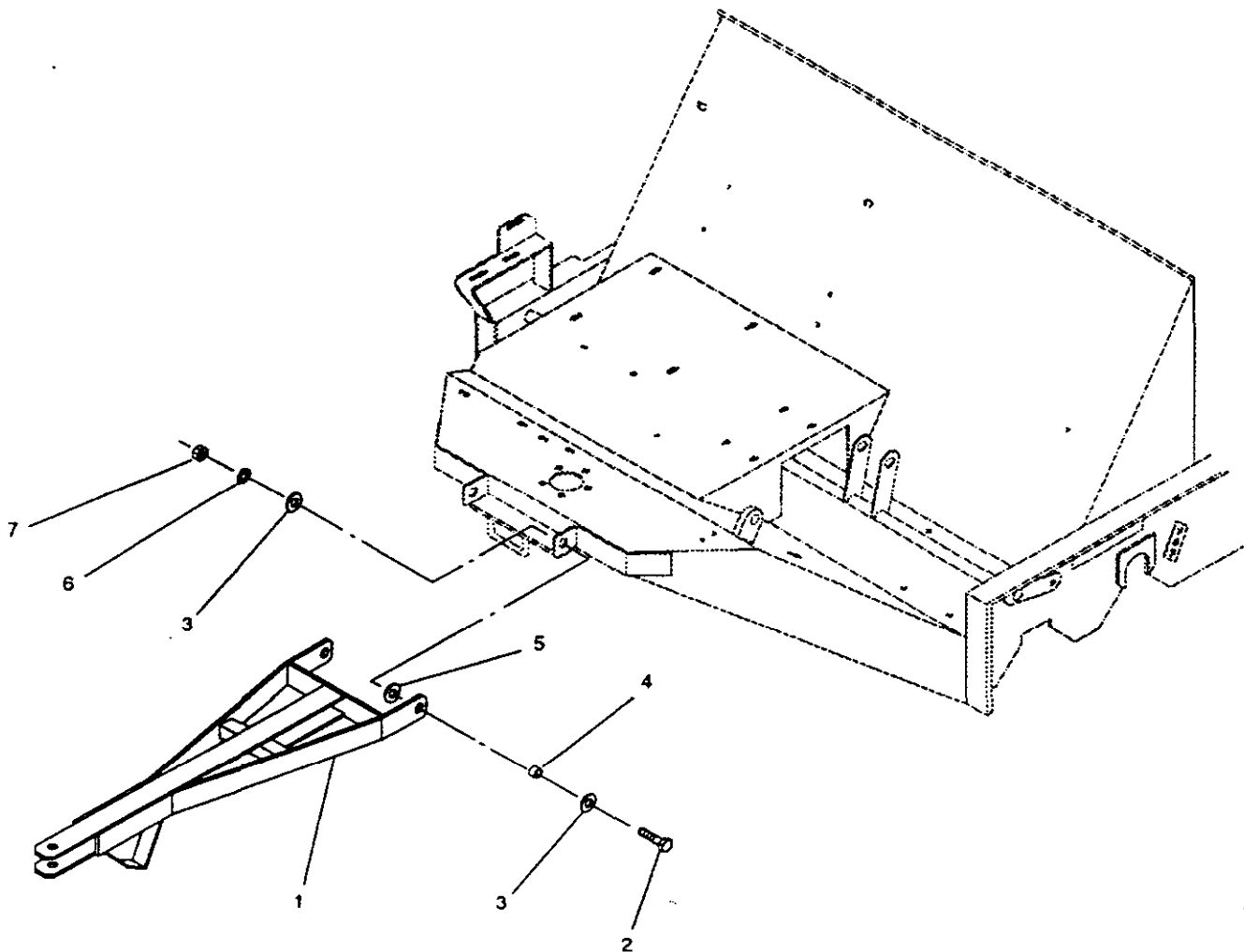

TONGUE ASSEMBLY

166HL-15

Ref. No.	Part No.	Description	No. Used
1	66-005-5452	Tongue	1
2	327-6	Capscrew - Hex Hd.	2
3	3256-7	Flat Washer	4
4	66-004-1401	Tongue Bushing	2

Ref. No.	Part No.	Description	No. Used
5	01-168-1414	Machinery Bushing	2
6	3253-8	Lock Washer	2
7	3217-11	Hex Nut	2

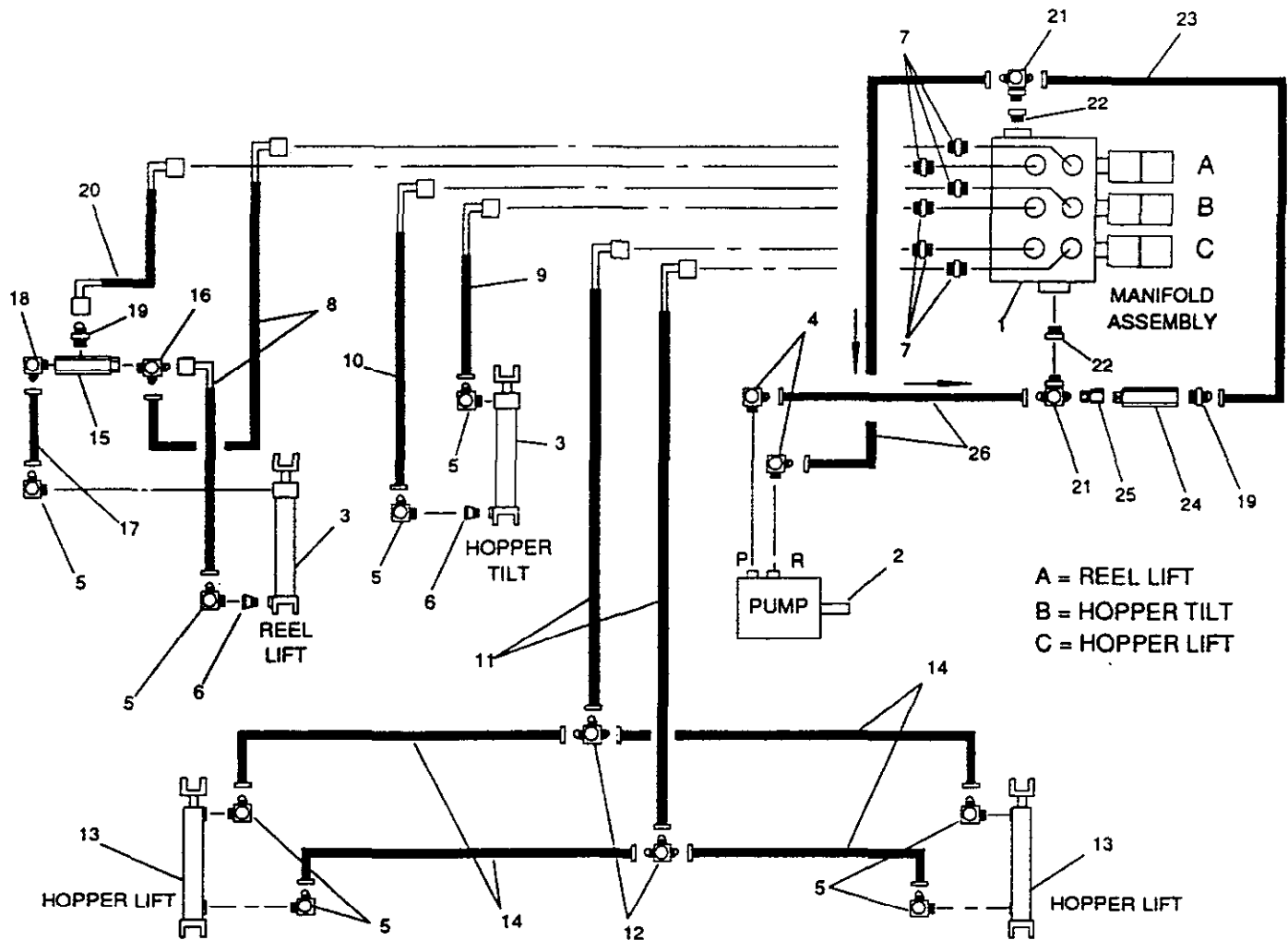

HYDRAULIC SCHEMATIC

166HL-16

Ref. No.	Part No.	Description	No. Used
1	01-308-0990	Manifold Assembly	1
2	01-305-0010	Hydraulic Pump	1
*	01-305-0620	Seal Kit	1
3	01-301-0060	Cylinder	2
*	01-301-0100	Seal Kit	1
4	01-201-0030	Fitting	2
5	01-201-0190	Fitting	8
6	01-310-0010	Flow Restrictor	2
7	01-201-0780	Fitting	6
8	01-312-3150	Hose Assembly	2
9	01-312-3040	Hose Assembly	1
10	01-312-3030	Hose Assembly	1
11	01-312-3050	Hose Assembly	2
12	01-201-0140	Fitting	2
13	01-301-0080	Cylinder	2
*	01-301-0100	Seal Kit	1

Ref. No.	Part No.	Description	No. Used
14	01-312-2840	Hose Assembly	4
15	01-308-1100	Check Valve	1
16	01-201-2970	Fitting	1
17	01-312-2280	Hose Assembly	1
18	01-201-1330	Fitting	1
19	01-201-1790	Fitting	2
20	01-312-3140	Hose Assembly	1
21	01-201-2990	Fitting	2
22	01-201-2980	Fitting	2
23	01-312-2570	Hose Assembly	1
24	01-308-1110	Relief Valve	1
25	01-201-3000	Fitting	1
26	01-312-2910	Hose Assembly	2

* Not Illustrated

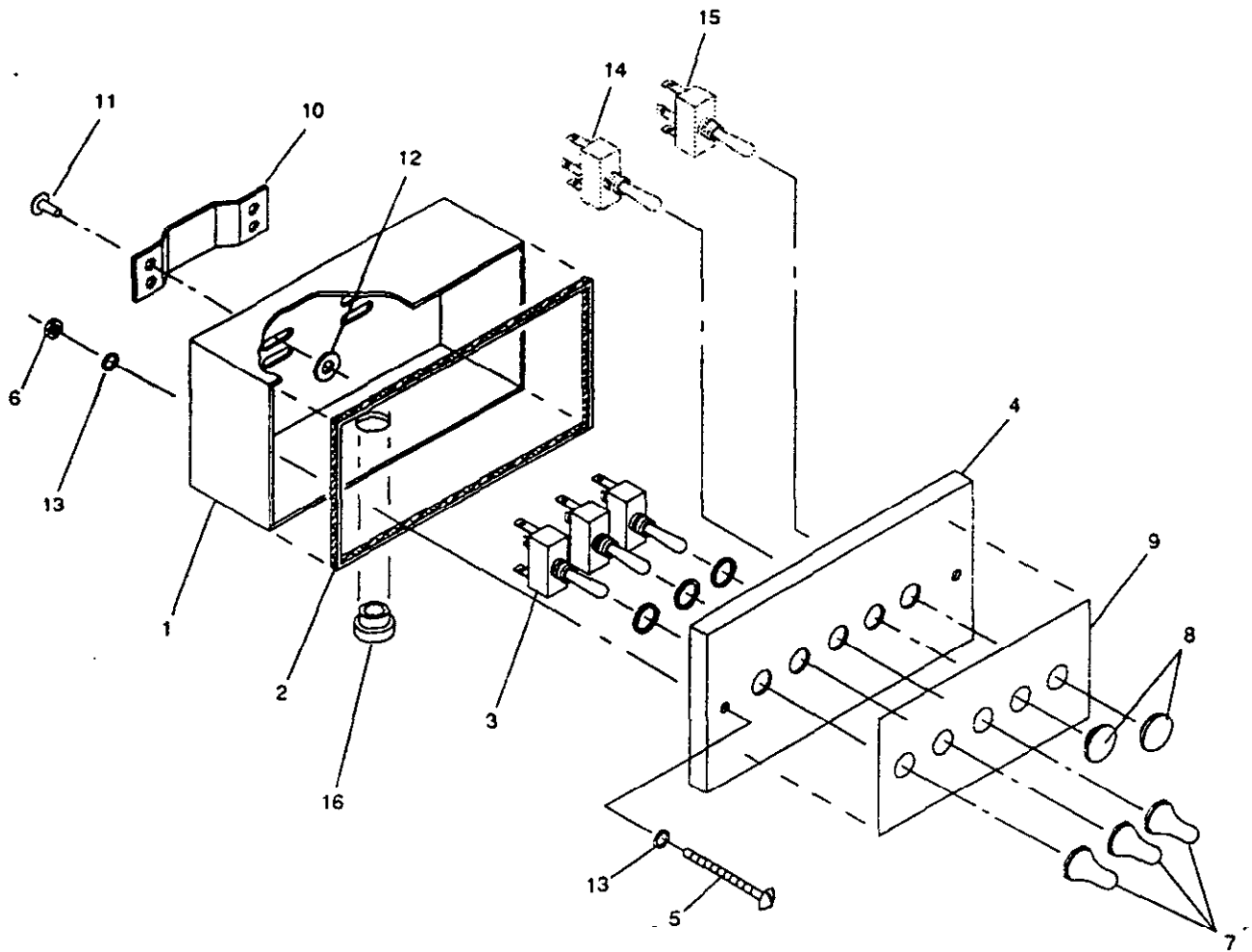

CONTROL BOX

166HL-17

Ref. No.	Part No.	Description	No. Used
1	66-005-4551	Control Box	1
2	66-004-4591	Seal - Control Box	1
3	01-603-0930	Switch	3
4	66-004-5351	Control Box Lid	1
5	01-158-1700	Machine Screw - Slotted Rd. Hd.	2
6	3217-27	Hex Nut	2
7	01-603-0760	Rubber Boot	3
8	01-127-0310	Rubber Plug	2
9	01-506-1260	Decal - Control Box	1
10	66-004-5371	Hanger Sleeve	1

Ref. No.	Part No.	Description	No. Used
11	01-161-0060	Pop Rivet	4
12	3256-51	Flat Washer	4
13	01-169-0150	Sealing Washer	4
14	01-603-0920	Switch - Thatcher (optional)	1
15	01-603-0910	Switch - Throttle (optional)	1
16	01-612-0620	Strain Relief	1
*	01-270-4140	Solenoid (Opt. *Whisper Switch)	1
*	01-606-0390	Wiring Harness	1

* Not Illustrated

CONTROL BOX WIRING DIAGRAM

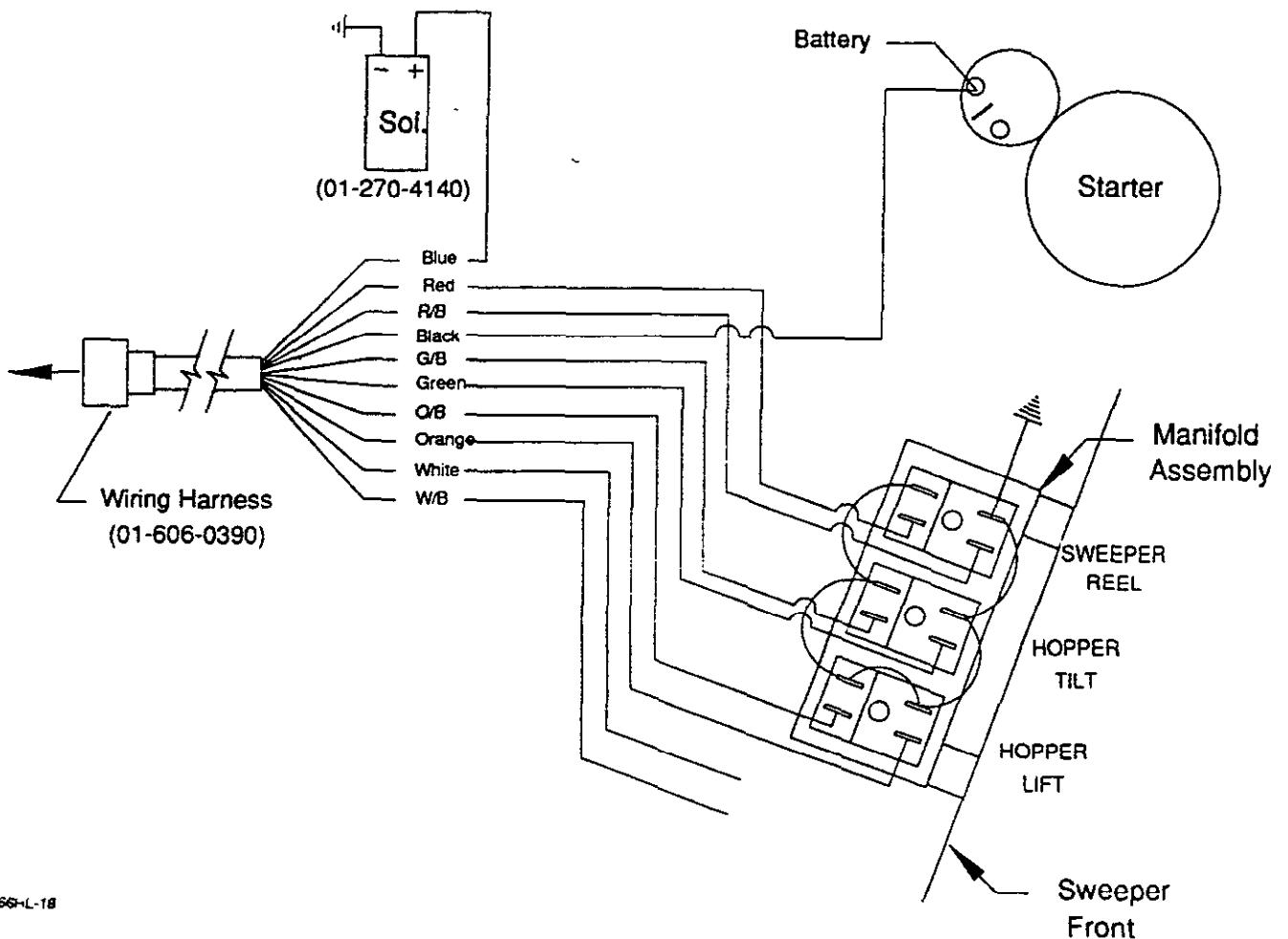
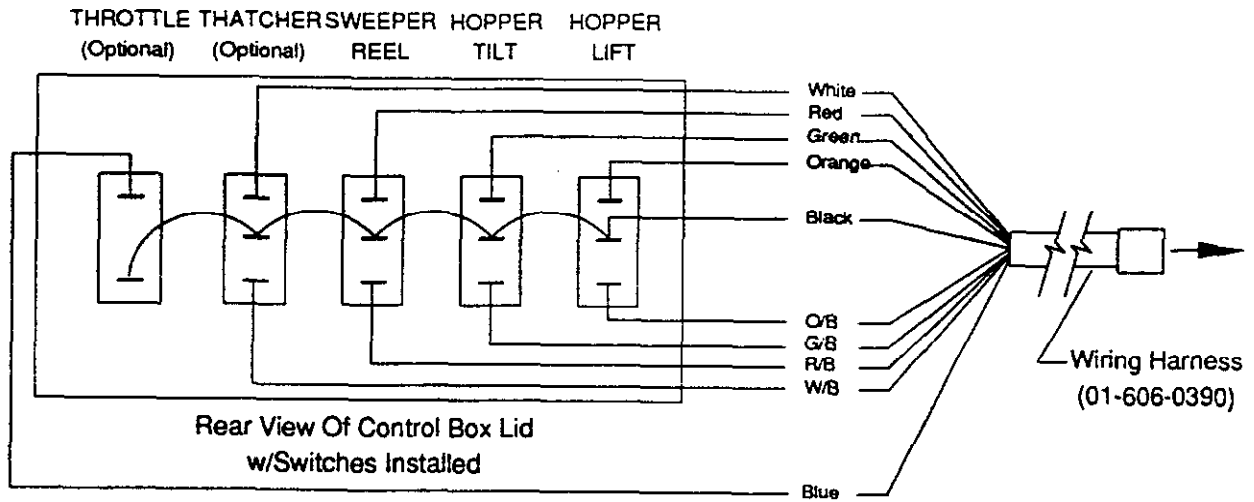

PART NUMBER INDEX

Part No.	Description	Pg. No.	Ref. No.	Qty.	Part No.	Description	Pg. No.	Ref. No.	Qty.
01-102-0050	Inner Bearing	3	15	1	01-201-3000	Fitting	17	25	1
01-102-0070	Outer Bearing	3	14	1	01-205-0150	Channel	13	14	1
01-102-0130	Bearing	3	8	10	01-215-0050	Grease Fitting	14	35	7
01-103-0040	Inner Race	3	12	1	01-215-0050	Grease Fitting	15	29	2
01-103-0130	Race	3	7	10	01-215-0050	Grease Fitting	3	24	1
01-103-0140	Outer Race	3	13	1	01-215-0050	Grease Fitting	4	9	4
01-105-0520	Needle Bearing	7	26	2	01-250-0020	Rod End Bearing	8	8	1
01-105-0520	Needle Bearing	8	16	2	01-251-0020	Offset Link	7	*	1
01-113-0010	Bearing	11	9	1	01-257-0010	Knob	13	15	3
01-113-0010	Bearing	5	9	1	01-260-0010	Sheave	11	14	1
01-113-0010	Bearing	7	15	1	01-260-0020	Sheave	5	17	1
01-113-0020	Bearing	11	4	1	01-260-0020	Sheave	6	8	1
01-113-0020	Bearing	7	5	1	01-260-0030	Sheave	11	17	1
01-125-0030	Bronze Bushing	14	11	5	01-260-0040	Sheave	5	14	1
01-127-0310	Rubber Plug	18	8	2	01-260-0040	Sheave	6	11	1
01-151-0060	Cotter Pin	14	8	12	01-260-0190	Bushing	5	15	1
01-158-1690	Screw - Pan Hd.	2	35	5	01-260-0230	Bushing	6	9	1
01-158-1700	Machine Screw - Slotted RH	18	5	2	01-260-0280	Bushing	11	18	1
01-161-0030	Pop Rivet	1	26	2	01-260-0290	Bushing	11	15	1
01-161-0030	Pop Rivet	8	23	2	01-261-0300	Spring	12	15	1
01-161-0060	Pop Rivet	18	11	4	01-261-0300	Spring	8	12	1
01-163-0030	Set Screw	5	7	4	01-262-0520	Sprocket	7	11	1
01-166-1200	Flat Washer	14	20	10	01-262-0530	Sprocket	7	22	1
01-166-1600	Flat Washer	14	9	9	01-262-0610	Sprocket	7	25	1
01-168-1014	Machinery Bushing	12	2	5	01-262-0610	Sprocket	8	15	1
01-168-1210	Machinery Bushing	3	3	2	01-263-0050	U-joint	5	6	1
01-168-1410	Machinery Bushing	7	23	6	01-264-0010	Belt	11	20	1
01-168-1410	Machinery Bushing	8	13	11	01-264-0190	Belt	5	18	1
01-168-1414	Machinery Bushing	16	5	2	01-264-0190	Belt	6	12	1
01-168-1414	Machinery Bushing	7	24	4	01-268-0010	Pulley	12	7	1
01-168-1414	Machinery Bushing	8	14	5	01-268-0040	Cable Pulley	14	29	1
01-168-1610	Machinery Bushing	1	11	4	01-268-0050	Cable Pulley	14	10	4
01-168-1610	Machinery Bushing	14	31	8	01-269-0060	Wheel Spacer	3	10	10
01-168-1610	Machinery Bushing	7	20	3	01-269-0140	Steering Hub	3	11	1
01-168-1614	Machinery Bushing	1	18	8	01-269-0300	Lug Nut	3	19	5
01-168-1614	Machinery Bushing	14	32	8	01-269-0320	Tire	3	6	5
01-168-1614	Machinery Bushing	7	21	6	01-269-0340	Wheel	3	5	5
01-168-1618	Machinery Bushing	14	33	8	01-270-4130	Engine	5	1	1
01-168-2010	Machinery Bushing	7	13	2	01-270-4140	Solenoid	18	*	1
01-168-2014	Machinery Bushing	7	10	3	01-273-0310	Exhaust Extension	5	24	1
01-169-0150	Sealing Washer	18	13	4	01-273-0430	Muffler Kit	5	11	1
01-170-0010	Cable Clamp	15	*	4	01-279-0010	Rubber Fingers	7	3	140
01-170-0160	Muffler Clamp	5	12	3	01-280-0300	Gas Tank Gasket	1	*	1
01-171-0010	Tumbuckle	15	12	1	01-280-0350	Cap & Gauge Unit	2	33	1
01-182-0614	Capscrew - Hex Hd.	13	12	2	01-286-0040	Dust Cap	3	20	1
01-182-0832	Capscrew - Hex Hd.	12	16	1	01-301-0060	Cylinder	1	15	1
01-182-0840	Capscrew - Hex Hd.	5	22	2	01-301-0060	Cylinder	14	6	1
01-182-1256	Capscrew - Hex Hd.	4	6	2	01-301-0060	Cylinder	17	3	2
01-189-0813	Lock Nut	10	11	2	01-301-0080	Cylinder	14	21	2
01-189-0813	Lock Nut	15	6	4	01-301-0080	Cylinder	17	13	2
01-189-0813	Lock Nut	9	11	2	01-301-0100	Seal Kit	1	*	1
01-190-1210	Castle Nut	3	4	5	01-301-0100	Seal Kit	14	*	1
01-190-1216	Castle Nut	3	18	1	01-301-0100	Seal Kit	14	*	1
01-192-0070	Wing Nut	14	26	2	01-301-0100	Seal Kit	17	*	1
01-201-0030	Fitting	17	4	2	01-301-0100	Seal Kit	17	*	1
01-201-0140	Fitting	17	12	2	01-305-0010	Hydraulic Pump	17	2	1
01-201-0190	Fitting	17	5	8	01-305-0010	Pump	6	1	1
01-201-0780	Fitting	17	7	6	01-305-0620	Seal Kit	17	*	1
01-201-1330	Fitting	17	18	1	01-305-0620	Seal Kit	6	*	1
01-201-1790	Fitting	17	19	2	01-308-0990	Manifold Assembly	17	1	1
01-201-2970	Fitting	17	16	1	01-308-0990	Manifold Assembly	6	13	1
01-201-2980	Fitting	17	22	2	01-308-1100	Check Valve	17	15	1
01-201-2990	Fitting	17	21	2	01-308-1110	Relief Valve	17	24	1

* Not Illustrated

PART NUMBER INDEX (Continued)

Part No.	Description	Pg. No.	Ref. No.	Qty.	Part No.	Description	Pg. No.	Ref. No.	Qty.
01-310-0010	Flow Restrictor	17	6	2	3217-7	Hex Nut	7	19	1
01-312-2280	Hose Assembly	17	17	1	3217-7	Hex Nut	8	9	4
01-312-2570	Hose Assembly	17	23	1	3217-8	Hex Nut	13	8	6
01-312-2840	Hose Assembly	17	14	4	3217-9	Hex Nut	11	8	2
01-312-2910	Hose Assembly	17	26	2	3217-9	Hex Nut	12	17	3
01-312-3030	Hose Assembly	17	10	1	3217-9	Hex Nut	14	5	16
01-312-3040	Hose Assembly	17	9	1	3217-9	Hex Nut	15	5	5
01-312-3050	Hose Assembly	17	11	2	3217-9	Hex Nut	5	23	2
01-312-3140	Hose Assembly	17	20	1	3217-9	Hex Nut	7	9	2
01-312-3150	Hose Assembly	17	8	2	3218-6	Jam Nut	10	6	1
01-405-0370	Seal	3	16	1	3218-6	Jam Nut	15	10	2
01-405-0460	Oil Seal	3	9	10	3218-6	Jam Nut	9	5	1
01-451-0120	Pipe Cap	5	29	1	3218-7	Jam Nut	14	18	8
01-453-0130	Pipe Coupling	5	26	1	322-5	Capscrew - Hex Hd.	15	19	9
01-455-0200	Street Elbow	5	27	1	3220-3	Jam Nut	8	7	3
01-456-0050	Pipe Nipple	5	25	1	323-10	Capscrew - Hex Hd.	5	10	2
01-456-0130	Pipe Nipple	5	28	1	323-6	Capscrew - Hex Hd.	1	6	4
01-506-0040	Decal - Danger	13	10	1	323-6	Capscrew - Hex Hd.	13	2	2
01-506-0050	Decal - Danger	8	21	1	323-6	Capscrew - Hex Hd.	14	14	6
01-506-0070	Decal - Danger	1	4	1	323-6	Capscrew - Hex Hd.	15	23	4
01-506-0080	Decal - Danger	1	23	1	323-6	Capscrew - Hex Hd.	5	20	2
01-506-0080	Decal - Danger	13	11	1	323-7	Capscrew - Hex Hd.	1	5	4
01-506-0150	Decal - Height Gauge	1	22	1	323-7	Capscrew - Hex Hd.	6	3	4
01-506-0460	Decal - Gas	1	19	1	323-8	Capscrew - Hex Hd.	11	10	2
01-506-0520	Decal - Toro	1	20	1	323-8	Capscrew - Hex Hd.	7	16	1
01-506-0530	Decal - Toro	15	28	1	323-9	Capscrew - Hex Hd.	5	2	4
01-506-0560	Decal - Hydraulic Oil	6	7	1	323-9	Capscrew - Hex Hd.	6	17	2
01-506-0780	Decal - Turf Sweeper 1655HL	1	21	2	3231-10	Carriage Bolt	14	24	2
01-506-1150	Decal - Danger	1	24	1	325-5	Capscrew - Hex Hd.	8	5	1
01-506-1260	Decal - Control Box	18	9	1	325-6	Capscrew - Hex Hd.	14	2	16
01-600-0090	Battery Cable	5	*	1	325-7	Capscrew - Hex Hd.	11	5	2
01-600-0260	Battery Cable	5	*	1	325-7	Capscrew - Hex Hd.	15	3	4
01-603-0760	Rubber Boot	18	7	3	325-7	Capscrew - Hex Hd.	7	6	2
01-603-0910	Switch - Throttle	18	15	1	3253-3	Lock Washer	2	31	4
01-603-0920	Switch - Thatcher	18	14	1	3253-3	Lock Washer	6	16	2
01-603-0930	Switch	18	3	3	3253-4	Lock Washer	15	21	9
01-606-0390	Wiring Harness	18	*	1	3253-5	Lock Washer	1	7	8
01-612-0620	Strain Relief	18	16	1	3253-5	Lock Washer	11	12	2
01-650-0400	All Thread	13	7	2	3253-5	Lock Washer	13	4	4
02-250-0020	Rod End Bearing	8	6	1	3253-5	Lock Washer	14	15	8
24-0610	Upper Felt Strip	2	28	2	3253-5	Lock Washer	15	25	4
24-0620	Tank Strap	1	27	2	3253-5	Lock Washer	5	4	8
25-8390	Lower Felt Strip	2	29	2	3253-5	Lock Washer	6	5	4
321-23	Capscrew - Hex Hd.	6	15	2	3253-5	Lock Washer	7	18	1
32121-10	Roll Pin	4	8	2	3253-7	Lock Washer	11	7	2
3217-11	Hex Nut	1	13	4	3253-7	Lock Washer	14	4	16
3217-11	Hex Nut	10	8	2	3253-7	Lock Washer	7	8	2
3217-11	Hex Nut	12	9	1	3253-7	Lock Washer	8	4	1
3217-11	Hex Nut	15	9	3	3253-8	Lock Washer	10	5	1
3217-11	Hex Nut	16	7	2	3253-8	Lock Washer	12	8	1
3217-11	Hex Nut	9	8	2	3253-8	Lock Washer	16	6	2
3217-12	Hex Nut	4	7	6	3253-8	Lock Washer	9	4	1
3217-27	Hex Nut	18	6	2	3256-26	"SAE" Flat Washer	14	30	8
3217-5	Hex Nut	2	32	4	3256-26	"SAE" Flat Washer	8	3	1
3217-6	Hex Nut	15	22	9	3256-27	"SAE" Flat Washer	10	4	1
3217-7	Hex Nut	1	8	4	3256-27	"SAE" Flat Washer	9	3	1
3217-7	Hex Nut	11	13	2	3256-28	"SAE" Flat Washer	3	17	1
3217-7	Hex Nut	12	12	4	3256-3	Flat Washer	15	20	9
3217-7	Hex Nut	13	5	8	3256-4	Flat Washer	1	10	12
3217-7	Hex Nut	14	16	6	3256-4	Flat Washer	11	11	2
3217-7	Hex Nut	15	26	4	3256-4	Flat Washer	12	14	3
3217-7	Hex Nut	5	5	8	3256-4	Flat Washer	13	3	15
3217-7	Hex Nut	6	6	6	3256-4	Flat Washer	14	25	2

* Not Illustrated

PART NUMBER INDEX (Continued)

Part No.	Description	Pg. No.	Ref. No.	Qty.	Part No.	Description	Pg. No.	Ref. No.	Qty.
3256-4	Flat Washer	15	24	8	48-005-0421	Axle Bolt Assembly	3	2	5
3256-4	Flat Washer	5	3	16	48-005-0591	Reel Lift Tube Assembly	10	9	1
3256-4	Flat Washer	6	4	8	48-005-0591	Reel Lift Tube Assembly	9	9	1
3256-4	Flat Washer	7	17	1	48-005-0611	Idler Arm	12	1	1
3256-4	Flat Washer	8	11	3	53-9990	Gas Tank	1	2	1
3256-5	Flat Washer	13	9	4	54-004-0941	Reel Chain	7	27	1
3256-5	Flat Washer	8	19	3	65-005-0281	Dump Cylinder Pivot Ass'y	14	13	1
3256-51	Flat Washer	18	12	4	66-002-0042	Hopper Door Assembly	15	2	1
3256-6	Flat Washer	10	10	6	66-002-0442	Hopper Assembly	15	1	1
3256-6	Flat Washer	11	6	2	66-004-1401	Tongue Bushing	16	4	2
3256-6	Flat Washer	12	18	2	66-004-1621	Air Deflector	1	9	1
3256-6	Flat Washer	14	3	24	66-004-1641	Lower Door Arm-L.H.	15	7	1
3256-6	Flat Washer	15	4	8	66-004-2141	Hopper Pivot Arm Bushing	14	19	4
3256-6	Flat Washer	7	7	2	66-004-2161	Spacer	4	3	4
3256-6	Flat Washer	9	10	6	66-004-2171	Cylinder Pin	1	16	1
3256-7	Flat Washer	1	14	4	66-004-2171	Cylinder Pin	14	22	2
3256-7	Flat Washer	12	6	2	66-004-2181	Cylinder Pin	14	12	1
3256-7	Flat Washer	15	11	6	66-004-3211	Key	11	16	1
3256-7	Flat Washer	16	3	4	66-004-3291	Cylinder Pin	14	34	2
3258-37	Machine Screw - Slotted RH	2	30	4	66-004-3361	Rear Door Lift Cable	15	27	1
327-14	Capscrew - Hex Hd.	12	4	1	66-004-3561	Fuel Line	1	*	1
327-16	Capscrew - Hex Hd.	4	2	4	66-004-3571	Door Spring	15	16	1
327-6	Capscrew - Hex Hd.	10	2	1	66-004-4141	Cylinder Pin	14	7	1
327-6	Capscrew - Hex Hd.	16	2	2	66-004-4182	Front Rubber Mount	15	17	1
327-6	Capscrew - Hex Hd.	9	6	1	66-004-4191	Rubber Flap	15	18	1
327-7	Capscrew - Hex Hd.	15	13	1	66-004-4341	Hole Cover	2	34	1
327-9	Capscrew - Hex Hd.	15	8	2	66-004-4361	Jack Shaft	5	8	1
3272-21	Cotter Pin	12	3	1	66-004-4371	Lower Tank Strap	1	25	2
3272-23	Cotter Pin	1	17	2	66-004-4382	Gas Tank Stand	1	3	1
3272-23	Cotter Pin	3	21	5	66-004-4491	Muffler Guard	5	13	1
3272-23	Cotter Pin	7	14	2	66-004-4531	Valve Spacer	6	14	2
3272-23	Cotter Pin	8	17	1	66-004-4591	Seal - Control Box	18	2	1
3272-25	Cotter Pin	7	28	1	66-004-5351	Control Box Lid	18	4	1
328-5	Capscrew - Hex Hd.	14	17	2	66-004-5371	Hanger Sleeve	18	10	1
328-8	Capscrew - Hex Hd.	14	28	2	66-005-0192	Lift Arm Assembly	14	1	1
3296-22	Lock Nut	12	11	1	66-005-0201	Reel Lift Rod Assembly-L.H.	9	7	1
3296-22	Lock Nut	6	19	2	66-005-0201	Reel Lift Rod Assembly-R.H.	10	7	1
3296-48	Lock Nut	8	20	3	66-005-0211	Lower Door Arm-R.H.	15	15	1
3296-53	Lock Nut	15	14	1	66-005-0231	Front Reel Assembly	11	2	1
3296-53	Lock Nut	4	4	4	66-005-0231	Front Reel Assembly	7	2	1
41-002-0061	Dipstick	6	2	1	66-005-0242	Rear Reel Assembly	11	1	1
48-002-5441	Idler Sprocket Assembly	7	*	1	66-005-0242	Rear Reel Assembly	7	1	1
48-002-5441	Idler Sprocket Assembly	8	*	1	66-005-0251	Upper Arm Assembly	14	27	2
48-004-1211	Belt Slip Pin	13	6	2	66-005-0271	Safety Stop	14	23	2
48-004-1711	Idler Spring Rod	12	13	1	66-005-0311	Tongue	16	1	1
48-004-1931	Key	5	16	1	66-005-0361	Rear Outrigger-L.H.	4	5	1
48-004-1931	Key	7	12	2	66-005-0371	Reel Height Indicator	8	22	1
48-004-3431	Hose Bracket	6	18	2	66-005-0381	Skid Assembly	4	1	2
48-004-3471	Spacer	12	5	1	66-005-0421	Hopper Stop Pad	1	12	2
48-004-3831	Battery Hold Down	5	21	1	66-005-3481	Yoke Assembly	3	1	1
48-004-3881	Spacer	8	2	1	66-005-4094	Main Frame	1	1	1
48-004-3891	Idler Spring Rod	8	10	1	66-005-4221	Rear Outrigger-R.H.	4	*	1
48-004-5841	Reel Plate Spacer	10	3	1	66-005-4551	Control Box	18	1	1
48-004-5841	Reel Plate Spacer	9	2	1	66-005-5421	Access Cover	13	13	1
48-005-0121	Spring Tension Adjustment	12	10	1	66-005-5431	Battery Bracket	5	19	1
48-005-0162	Idler Cover	8	18	1	66-005-5442	Belt Guard	13	1	1
48-005-0172	Reel Plate Assembly-R.H.	10	1	1	66-6840	Decal - Warning	13	16	1
48-005-0172	Reel Plate Assembly-R.H.	11	3	1	75-5190	Decal - No Riders	13	17	1
48-005-0182	Reel Plate Assembly-L.H.	9	1	1	82-004-1171	Key	11	19	1
48-005-0182	Reel Plate Assembly	7	4	1	84-004-2851	Key	6	10	1
48-005-0191	Idler Shaft Assembly	8	1	1					

* Not Illustrated

PRODUCT CHANGES

In an effort to make improvements available to TORO owners as quickly as possible minor changes are incorporated into Toro's products from time to time that do not become immediately shown in the Parts Catalog. If such a change has been made in your unit which is not reflected in your manual see your TORO Distributor or an Authorized Service Dealer for information and part numbers.

IDENTIFICATION & ORDERING

MODEL AND NUMBERS

The 1655HL has two identification numbers; a model number and a serial number. The two numbers are stamped on a plate which is located on the control base. In any correspondence concerning the 1655HL, supply model and serial numbers to assure that correct information and replacement parts are obtained.

To order replacement parts from your TORO Distributor or an Authorized Service Dealer, supply the following information:

1. Model and serial number of the 1655HL.
2. Part number description and the quantity of part (s) desired.

NOTE: Do not order by reference number if a parts catalog is being used: use the PART NUMBER.

TABLE OF CONTENTS

Description	Page	Description	Page
Main Frame Assembly	1 - 2	Belt Idler Assembly	12
Wheel Assembly	3	Belt Guard & Belt Slip Pins	13
Skid Assembly	4	Lift Arm Assembly	14
Engine Mounting	5	Hopper Assembly	15
Pump Mounting	6	Tongue Assembly	16
Sweeper Reel & Timing Chain Assembly	7	Hydraulic Schematic	17
Chain Idler & Guard Assembly	8	Control Box	18
Reel Lift Assembly - L.H.	9	Control Box Wiring Diagram	19
Reel Lift Assembly - R.H.	10	Part Number Index	20 - 22
Belt Drive Assembly	11		

