

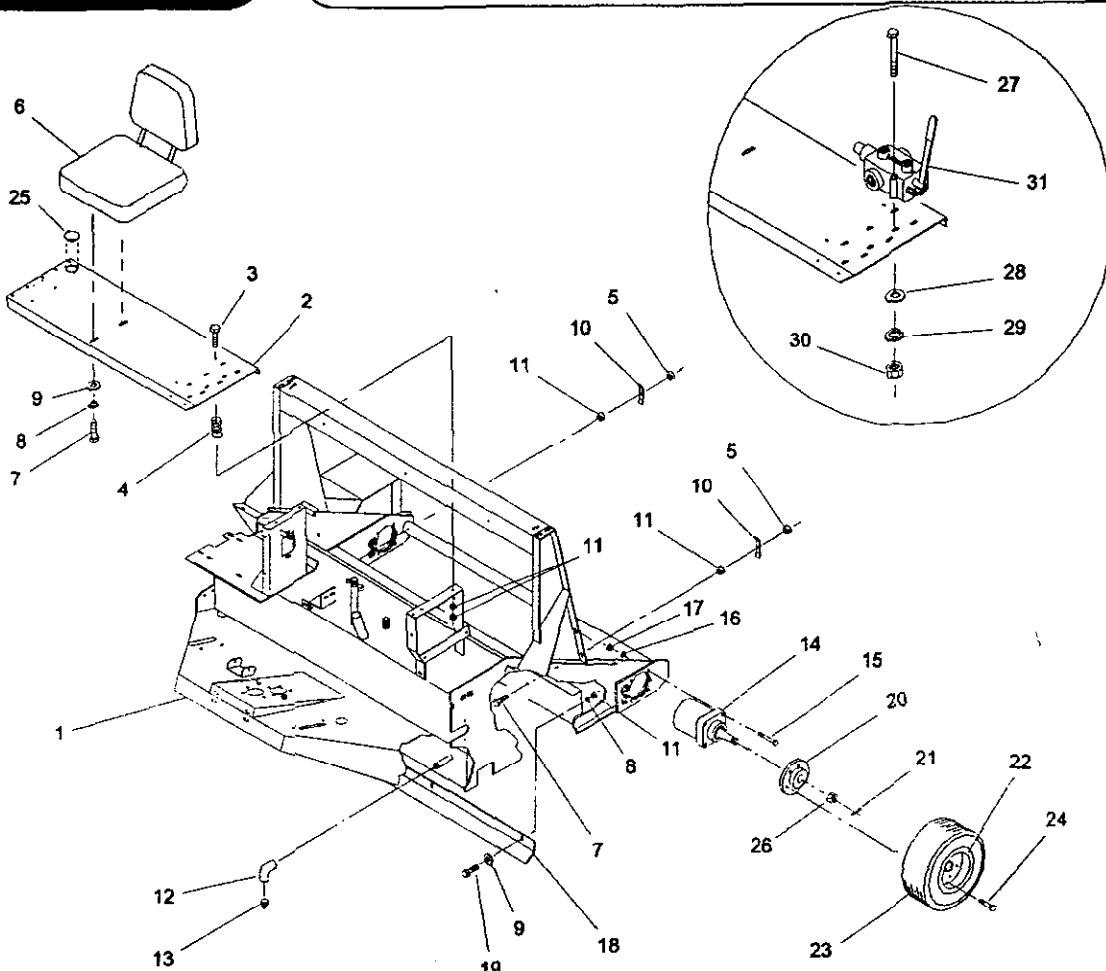

MODEL NO. 44050 - 50105 & UP MODEL NO. 44055 - 50111 & UP	<b>PARTS CATALOG</b>
<b>TURF SWEEPER 4800HL</b>	



**MAIN FRAME ASSEMBLY**

48HL-001

Ref. No.	Part No.	Description	No. Used
1	48-005-0774	Main Frame	1
2	48-005-0462	Seat Mount	1
3	323-10	Capscrew - Hex Hd.	4
4	01-261-0240	Spring	4
5	3296-39	Lock Nut	2
6	01-286-0220	Seat	1
7	01-182-0616	Capscrew - Hex Hd.	4
8	3253-5	Lock Washer	5
9	3256-4	Flat Washer	5
10	48-004-1861	Hose Hold Down Bracket	2
11	3217-7	Hex Nut	13
12	01-455-0100	Elbow	1
13	01-451-0010	Pipe Plug	1
14	01-304-0410	Hydraulic Motor	2
		(Incl. Ref. #26)	
*	01-304-0260	Seal Kit	1
15	325-12	Capscrew - Hex Hd.	8
16	3253-7	Lock Washer	8
17	3		

Ref. No.	Part No.	Description	No. Used
217-9		Hex Nut	8
18	48-004-1751	Air Deflector	1
19	323-6	Capscrew - Hex Hd.	3
20	01-269-2540	Wheel Hub	2
21	01-151-0170	Cotter Pin	2
22	01-269-1020	Wheel	2
23	01-269-0330	Tire	2
24	01-158-2040	Lug Bolt	10
25	01-288-0020	Hour Meter (Onan)	1
*	01-127-0070	Plastic Plug (B & S)	1
26	01-190-1620	Castle Nut (Incl. w/Ref. #14)	2
27	322-12	Capscrew - Hex Hd.	4
28	3256-3	Flat Washer	4
29	3253-4	Lock Washer	4
30	3217-6	Hex Nut	4
31	01-308-0050	Valve	2
*	01-308-0130	Seal Kit	1

\* Not Illustrated

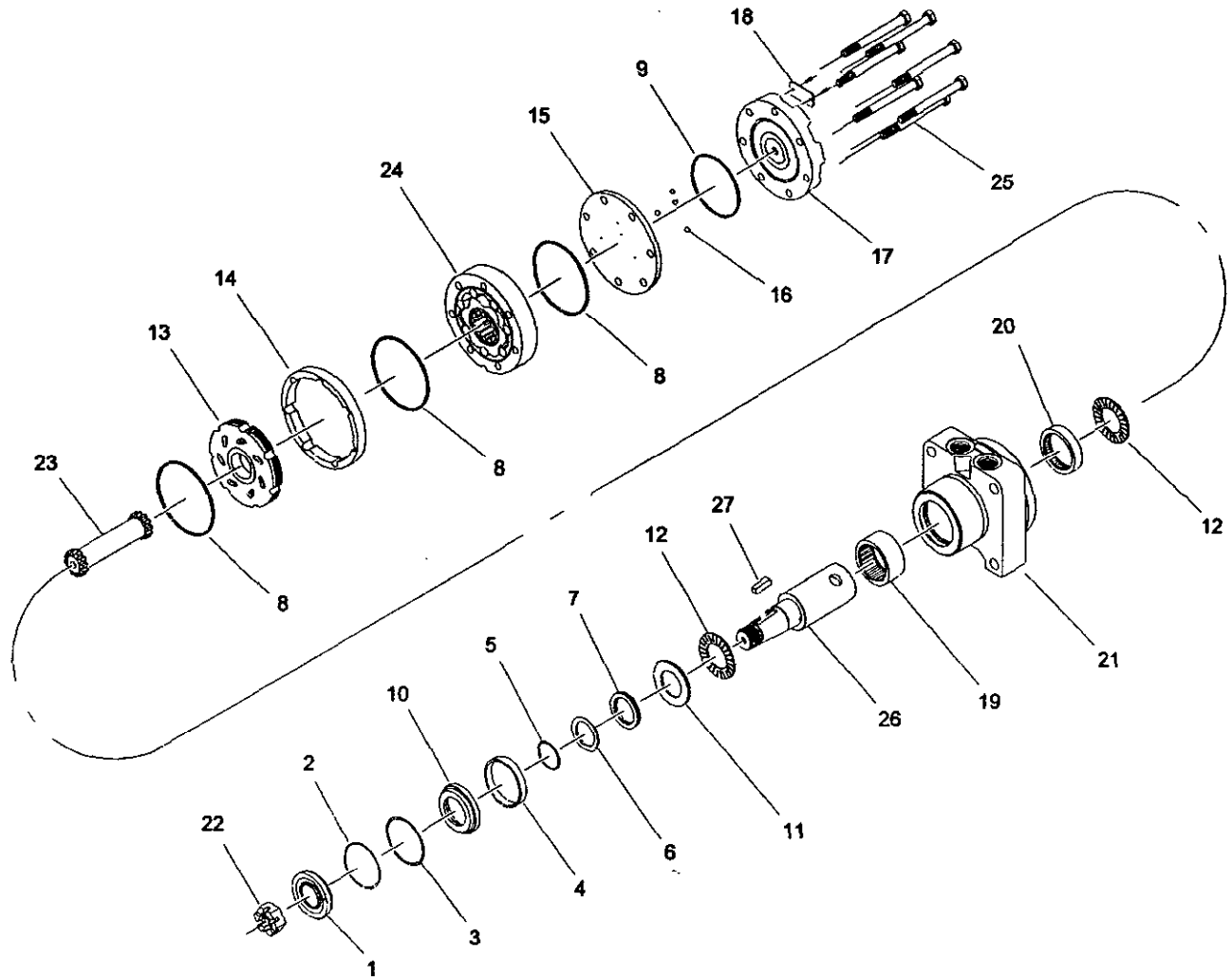

## HYDRAULIC MOTOR - NO. 01-304-0410

HYDM0410

Ref. No.	Part No.	Description	No. Used
1		Dust Seal	1
2		Snap Ring	1
3		Backup Shim	1
4		Lathe Cut Seal	1
5		Backup Shim	1
6		Teflon Backup	1
7		Shaft Seal	1
8		Body Seal	3
9		Endcover Seal	1
10		Seal Carrier	1
11		Thrust Washer	1
*	01-304-0260	Seal Kit (Incl. #1 - 11)	1
12	01-304-0660	Thrust Bearing	2
13	01-304-1560	Manifold (CCW)	1
14	01-304-1550	Manifold Boot	1

Ref. No.	Part No.	Description	No. Used
15		Balance Plate	1
16		Ball (3/16" steel)	4
*	01-304-1570	Balance Plate Kit (Incl. #15,16)	1
17	01-304-1580	Endcover	1
18		I. D. Tag Assembly	1
19		Roller Bearing	1
20		Roller Bearing	1
21		Housing	1
*	01-304-0840	Housing Kit (Incl. #19 - 21)	1
22	01-190-1620	Castle Nut	1
23	01-304-0850	Drive Link	1
24	01-304-0860	Rotor Set	1
25	01-304-0870	Bolt Set (7)	1
26	01-304-0490	Shaft	1
27	01-304-0880	Shaft Key	1

\* Not Illustrated

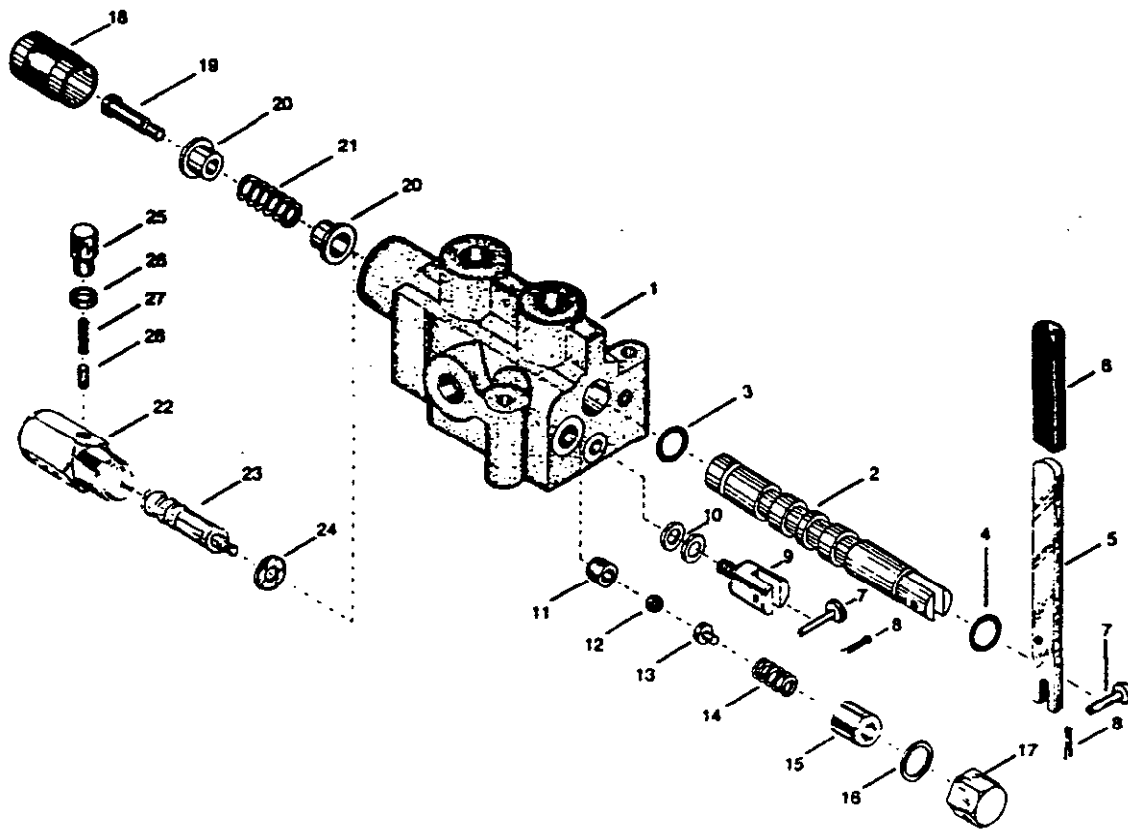

## HYDRAULIC VALVE - NO. 01-308-0050

VLE-0050

Ref. No.	Part No.	Description	No. Used
1		Casting, Body	1
2		Spool, 4-way	1
3		O-Ring, Spool	1
4		O-Ring, Casting	1
5	01-308-0190	Lever	1
6		Knob	1
7	01-308-1750	Pin	2
8		Cotter Pin	2
9		Pivot Clevis	1
10		Washer	2
11		Seal	1
12		Ball	1
13		Socket, Ball	1
14		Spring	1
15		Screw, Adjustment	1
16	01-169-0070	Washer	1
17		Cap, Relief	1

Ref. No.	Part No.	Description	No. Used
18		Cap	1
19		Bolt, Shoulder	1
20		Stop, Spool	2
21		Spring	1
*	01-308-0140	Spring Centered Assembly Kit (Incl. Ref. # 18-21)	1
22		Cap, Detent	1
23		Bolt, Detent	1
24		Stop, Spool	1
25		Cap, Point	1
26		Washer	1
27		Spring	1
28		Point	1
*	01-308-0150	Detent Kit (Incl. Ref. # 22-28)	1
*	01-308-0130	Valve Repair Kit	1

\* Not Illustrated

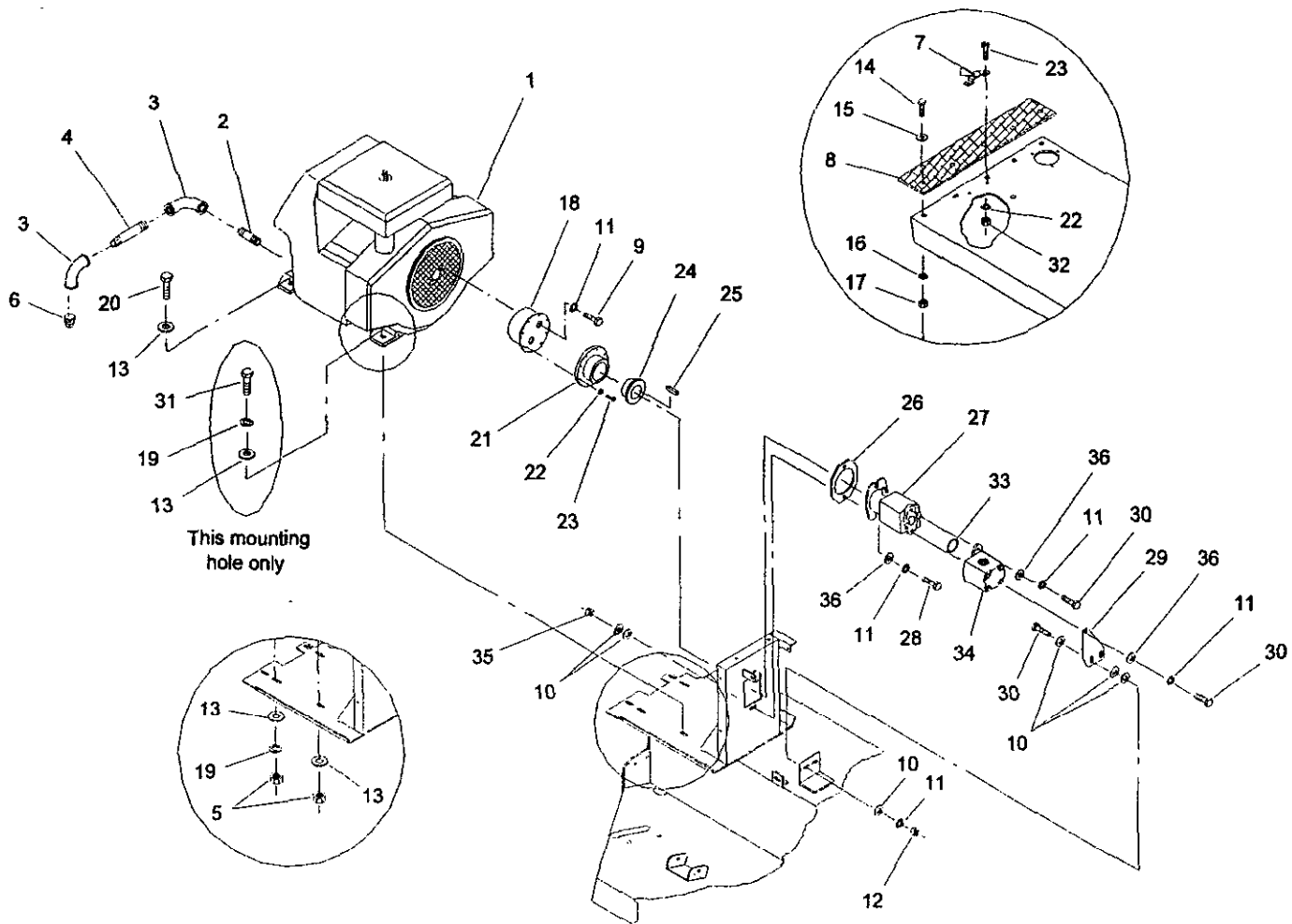

## BRIGGS & STRATTON ENGINE MOUNTING - MODEL NO. 44050

48HL-006

Ref. No.	Part No.	Description	No. Used
1	01-270-1640	Engine	1
*	01-600-0050	Battery Cable (neg.)	1
*	01-600-0060	Battery Cable (pos.)	1
2	01-456-0050	Pipe Nipple	1
3	01-455-0030	Pipe Elbow	2
4	01-456-0070	Pipe Nipple	1
5	3217-6	Hex Nut	4
6	01-451-0020	Pipe Plug	1
7	48-002-0071	Throttle Assembly	1
*	01-256-0020	Throttle Handle	1
*	48-004-4071	Throttle Outer Sheath	1
*	48-004-4081	Throttle Inner Wire	1
8	48-004-6441	Flywheel Guard	1
9	323-8	Capscrew - Hex Hd.	2
10	3256-4	Flat Washer	10
11	3253-5	Lock Washer	8
12	3217-7	Hex Nut	2
13	3256-3	Flat Washer	8
14	321-6	Capscrew - Hex Hd.	5
15	3256-2	Flat Washer	5
16	3253-3	Lock Washer	5
17	3217-5	Hex Nut	5
18	48-004-5052	Engine Adaptor	1

Ref. No.	Part No.	Description	No. Used
19	3253-4	Lock Washer	4
20	322-7	Capscrew - Hex Hd.	3
21	01-265-0180	Flex Coupling	1
22	01-169-0010	Lock Washer	10
23	01-158-0150	Capscrew - Socket Hd.	10
24	01-260-0900	"H" Bushing	1
25	48-004-5071	Key	1
26	48-004-5521	Cessna Pump Spacer	1
27	01-305-0090	Cessna Pump	1
*	48-005-0641	Tow Valve Handle	1
*	01-163-0100	Set Screw	1
*	01-305-0080	Seal Kit	1
28	323-10	Capscrew - Hex Hd.	2
29	48-004-3131	Pump Support	1
30	323-7	Capscrew - Hex Hd.	4
31	322-6	Capscrew - Hex Hd.	1
32	3217-26	Hex Nut	2
33	01-402-0230	O-Ring	1
34	01-305-0020	Sundstrand Pump	1
*	01-305-0600	Seal Kit	1
35	3296-39	Lock Nut	2
36	3256-24	"SAE" Flat Washer	4

\* Not Illustrated

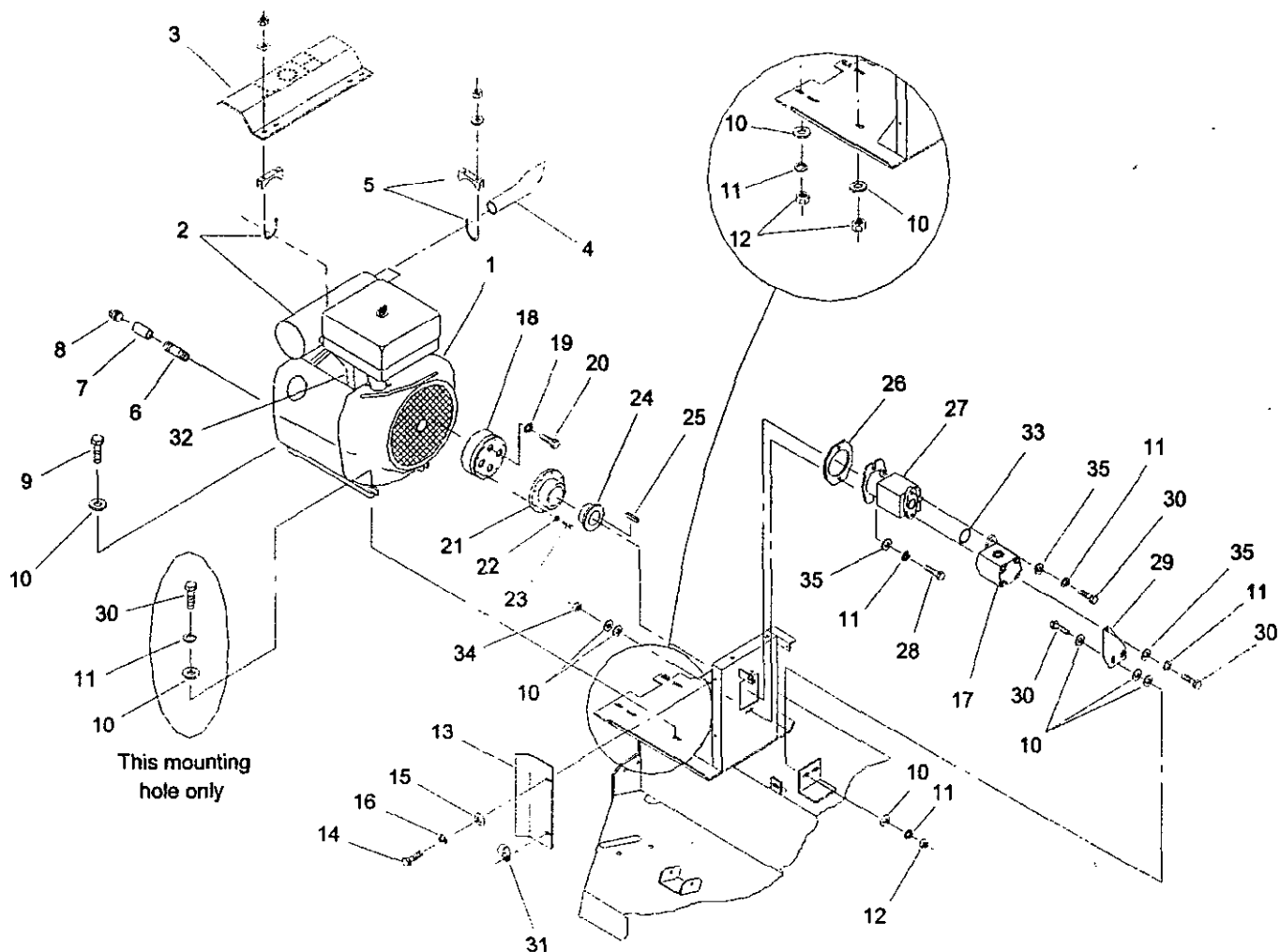

## ONAN ENGINE MOUNTING - MODEL NO. 44055

48HL-005

Ref. No.	Part No.	Description	No. Used
1	01-270-1370	Engine	1
*	01-600-0050	Battery Cable (neg.)	1
*	01-600-0190	Battery Cable (pos.)	1
2	01-273-0240	Muffler Kit, Includes clamps & muffler	1
3	48-004-5651	Muffler Guard	1
4	01-273-0310	Exhaust Extension	1
5	01-170-0160	Clamp	1
6	01-456-0050	Pipe Nipple	1
7	01-453-0130	Pipe Coupling	1
8	01-451-0020	Pipe Plug	1
9	323-8	Capscrew - Hex Hd.	3
10	3256-4	Flat Washer	20
11	3253-5	Lock Washer	10
12	3217-7	Hex Nut	6
13	48-004-6391	Flywheel Guard	1
14	321-6	Capscrew - Hex Hd.	2
15	3256-2	Flat Washer	2
16	3253-3	Lock Washer	2
17	01-305-0020	Sundstrand Pump	1
*	01-305-0600	Seal Kit	1
18	48-004-5062	Engine Adaptor	1

Ref. No.	Part No.	Description	No. Used
19	3253-4	Lock Washer	4
20	322-6	Capscrew - Hex Hd.	4
21	01-265-0180	Flex Coupling	1
22	01-169-0010	Lock Washer	8
23	01-158-0150	Capscrew - Socket Hd.	8
24	01-260-0900	"H" Bushing	1
25	48-004-5071	Key	1
26	48-004-5521	Cessna Pump Spacer	1
27	01-305-0090	Cessna Pump	1
*	48-005-0641	Tow Valve Handle	1
*	01-163-0100	Set Screw	1
*	01-305-0080	Seal Kit	1
28	323-10	Capscrew - Hex Hd.	2
29	48-004-3131	Pump Support	1
30	323-7	Capscrew - Hex Hd.	5
31	01-202-0190	Cable Clamp	1
32	01-273-0250	Muffler Tube Kit, Includes tubes, bolts & gaskets	1
33	01-402-0230	O-Ring	1
34	3296-39	Lock Nut	2
36	3256-24	"SAE" Flat Washer	4

\* Not Illustrated

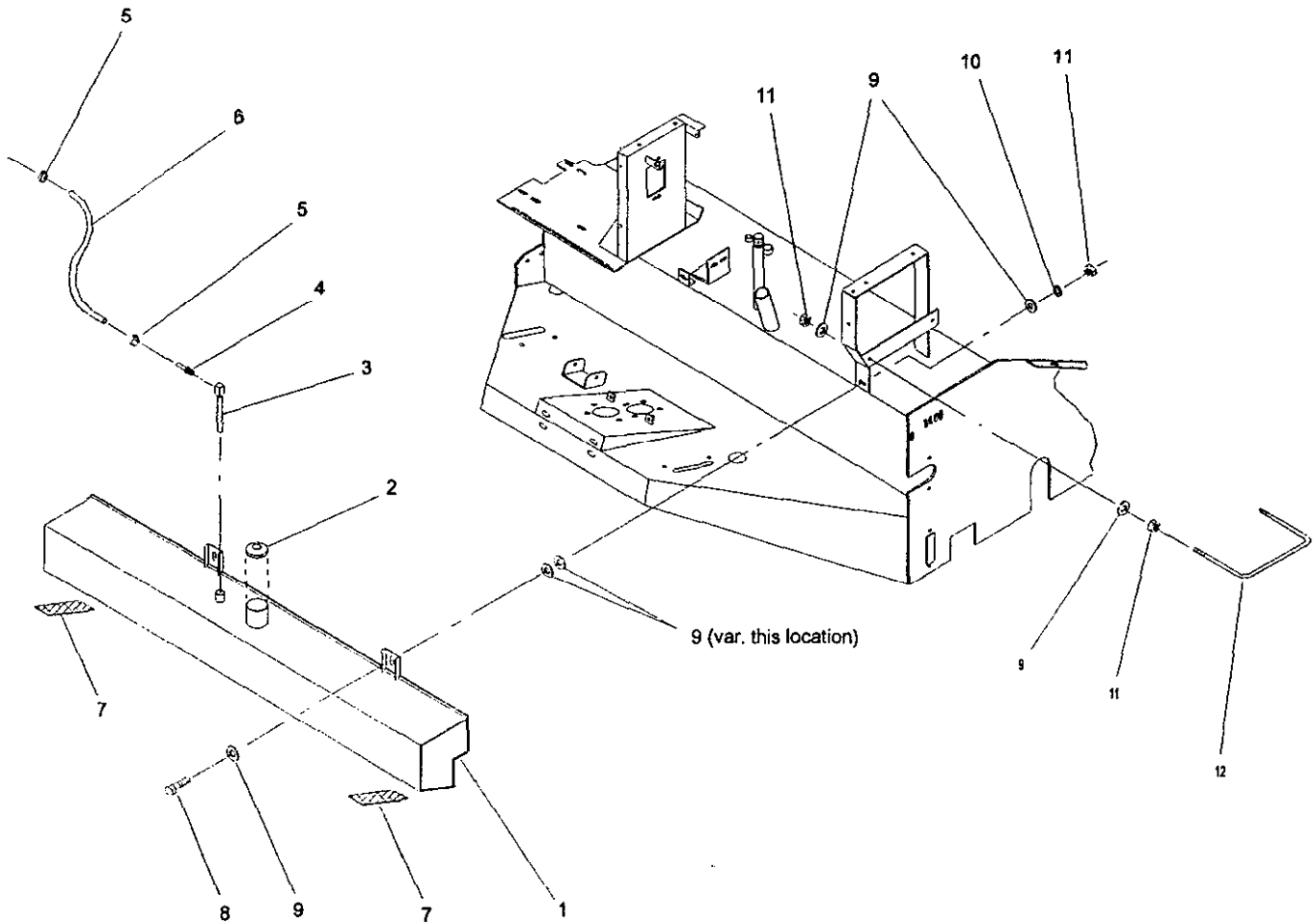

## GAS TANK & BATTERY HOLD DOWN

48-007

Ref. No.	Part No.	Description	No. Used
1	48-005-0712	Gas Tank	1
2	01-280-0020	Gas Cap - Type A - Vented	1
3	01-280-0190	Tank Withdrawal Assembly	1
4	01-217-0060	Hose Barb	1
5	01-202-0030	Hose Clamp	2
6	48-004-6261	Fuel Line (Onan)	1
*	48-004-4111	Fuel Line (B & S)	1

Ref. No.	Part No.	Description	No. Used
7	48-004-5131	PVK80 Rubber	2
8	323-7	Capscrew - Hex Hd.	2
9	3256-4	Flat Washer	12(var)
10	3253-5	Lock Washer	2
11	3217-7	Hex Nut	6
12	48-004-3831	Battery Hold Down	1

\* Not Illustrated

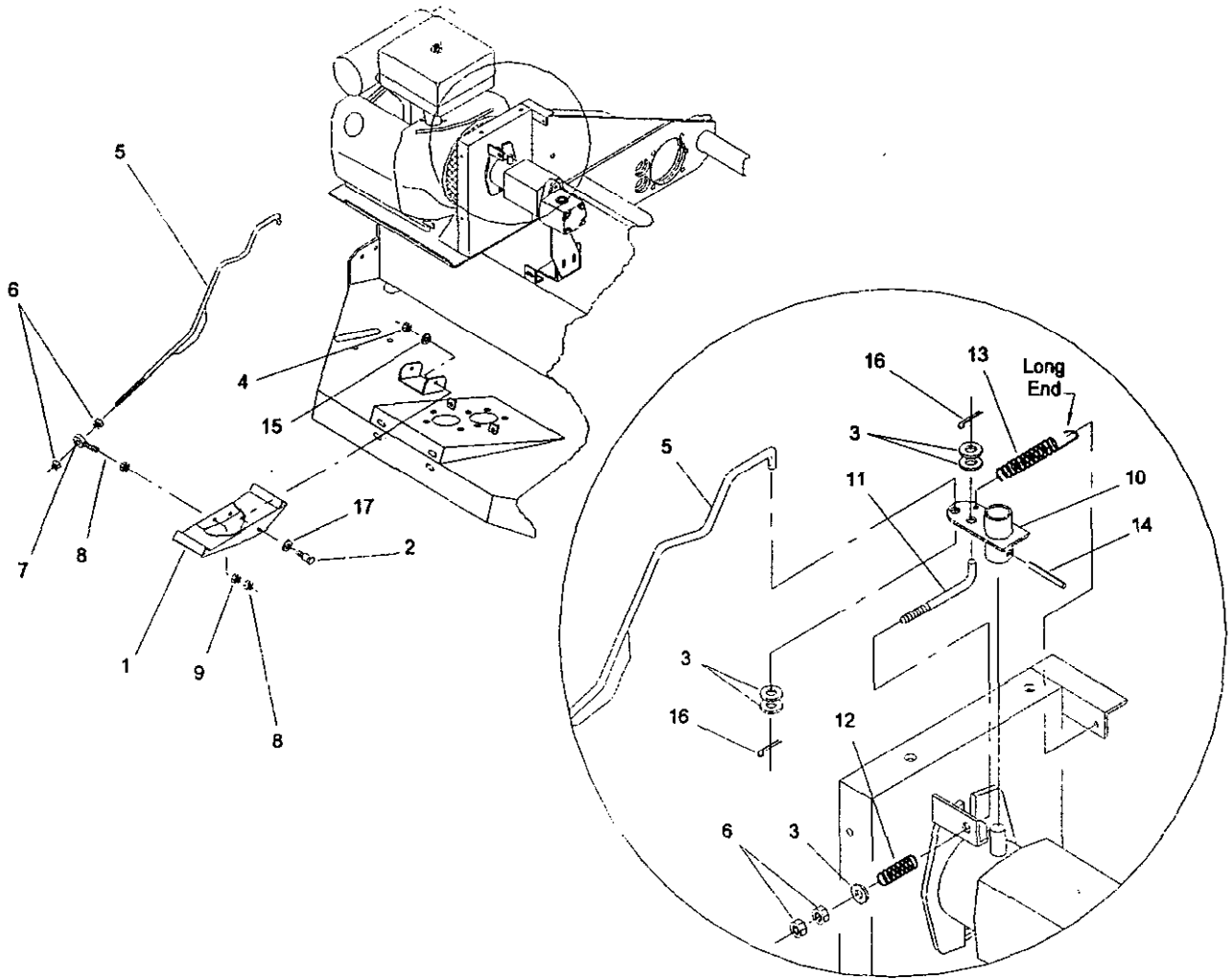

## FOOT PEDAL & PUMP CONTROL ROD ASSEMBLY

48-003

Ref. No.	Part No.	Description	No. Used
1	48-005-0621	Foot Pedal	1
2	01-158-0270	Shoulder Bolt	2
3	3256-4	Flat Washer	5
4	01-189-0518	Lock Nut	2
5	48-005-8231	Control Rod	1
6	3217-7	Hex Nut	4
7	01-250-0020	Rod End Bearing	1
8	3220-3	Jam Nut	2
9	3219-3	Hex Nut	1

Ref. No.	Part No.	Description	No. Used
10	48-005-0241	Pump Control Arm Assembly	1
11	48-004-2601	Spring Rod	1
12	01-261-0330	Spring	1
13	01-261-0930	Spring	1
14	32121-12	Roll Pin	1
15	3256-2	Flat Washer	2
16	3272-11	Cotter Pin	2
17	3256-23	"SAE" Flat Washer	2

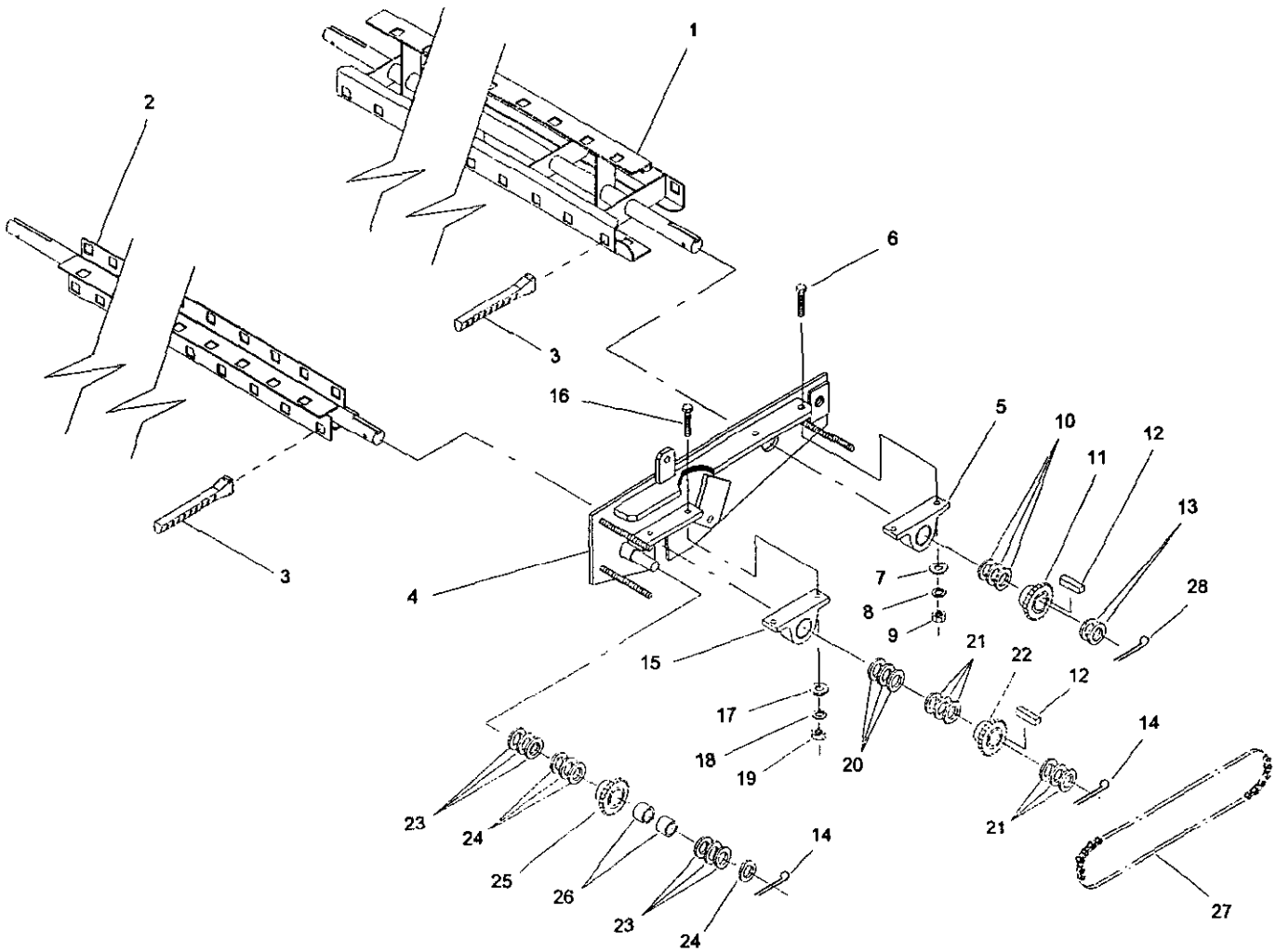

## SWEEPER REEL & TIMING CHAIN ASSEMBLY

48-008

Ref. No.	Part No.	Description	No. Used
1	48-005-0201	Rear Reel Assembly	1
2	48-005-0131	Front Reel Assembly	1
3	01-279-0010	Rubber Fingers	116
4	48-005-0182	Reel Plate Assembly, L.H.	1
5	01-113-0020	Bearing	1
6	325-7	Capscrew - Hex Hd.	2
7	3256-26	"SAE" Flat Washer	2
8	3253-7	Lock Washer	2
9	3217-9	Hex Nut	2
10	01-168-2014	Machinery Bushing	3(var)
11	01-262-0040	Sprocket	1
12	48-004-1931	Key	2
13	01-168-2010	Machinery Bushing	2
14	3272-23	Cotter Pin	2
15	01-113-0010	Bearing	1
16	323-8	Capscrew - Hex Hd.	1

Ref. No.	Part No.	Description	No. Used
17	3256-24	"SAE" Flat Washer	1
18	3253-5	Lock Washer	1
19	3217-7	Hex Nut	1
20	01-168-1610	Machinery Bushing	3(var)
21	01-168-1614	Machinery Bushing	6(var)
22	01-262-0050	Sprocket	1
23	01-168-1410	Machinery Bushing	6(var)
24	01-168-1414	Machinery Bushing	4(var)
25	01-262-0610	Sprocket	1
26	01-105-0520	Needle Bearing	2
*	48-002-5441	Idler Sprocket Assembly (Incl. Ref. #25, 26)	1
27	48-004-4041	Reel Chain, #50	1
*	01-251-0020	Offset Link	1
28	3272-25	Cotter Pin	1

\* Not Illustrated

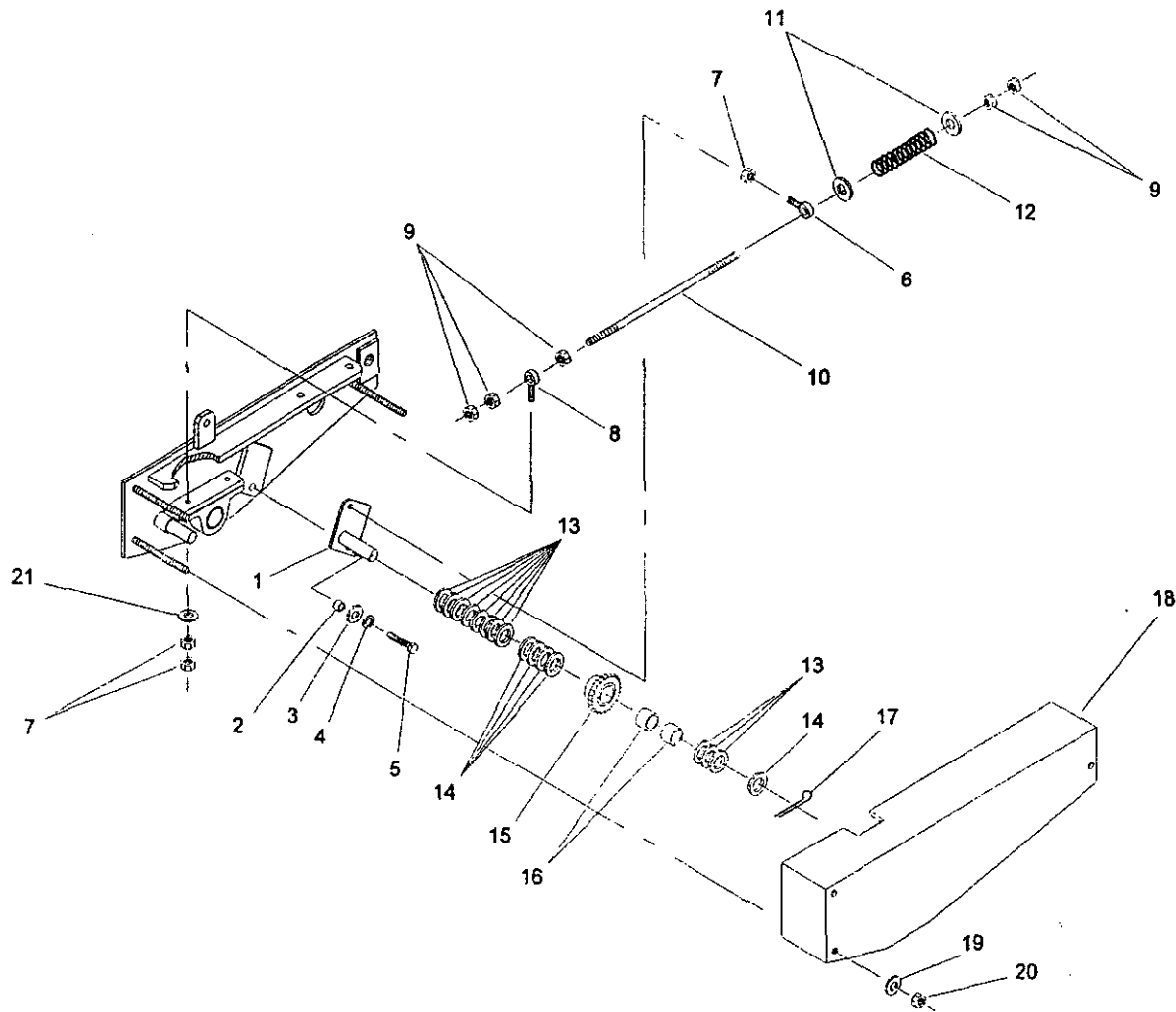

## CHAIN IDLER & GUARD ASSEMBLY

48-009

Ref. No.	Part No.	Description	No. Used
1	48-005-0191	Idler Shaft Assembly	1
2	48-004-3881	Spacer	1
3	3256-26	"SAE" Flat Washer	1
4	3253-7	Lock Washer	1
5	325-5	Capscrew - Hex Hd.	1
6	02-250-0020	Rod End Bearing (short)	1
7	3220-3	Jam Nut	3
8	01-250-0020	Rod End Bearing	1
9	3217-7	Hex Nut	5
10	48-004-3891	Idler Spring Rod	1
11	3256-4	Flat Washer	2
12	01-261-0300	Spring	1

Ref. No.	Part No.	Description	No. Used
13	01-168-1410	Machinery Bushing	11(var)
14	01-168-1414	Machinery Bushing	5(var)
15	01-262-0610	Sprocket	1
16	01-105-0520	Needle Bearing	2
*	48-002-5441	Idler Sprocket Assembly (Incl. Ref. # 15, 16)	1
17	3272-23	Cotter Pin	1
18	48-005-0162	Idler Cover	1
19	3256-5	Flat Washer	3
20	3296-48	Lock Nut	3
21	3256-24	"SAE" Flat Washer	1

\* Not Illustrated

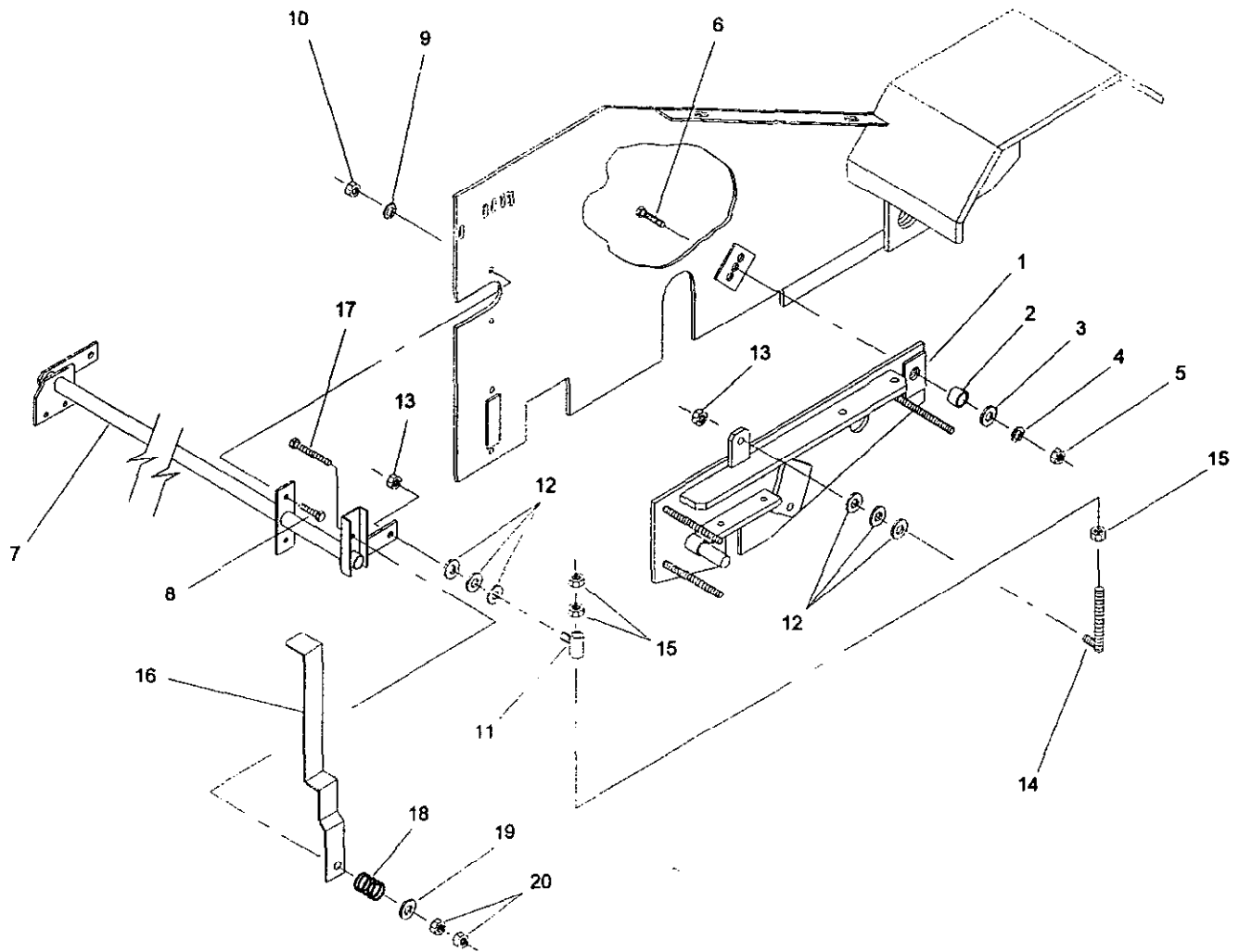

### REEL LIFT ASSEMBLY - L.H.

48-010

Ref. No.	Part No.	Description	No. Used
1	48-005-0182	Reel Plate Assembly-L.H.	1
2	48-004-5841	Reel Plate Spacer	1
3	3256-27	"SAE" Flat Washer	1
4	3253-8	Lock Washer	1
5	3218-6	Jam Nut	1
6	327-6	Capscrew - Hex Hd.	1
7	48-005-0432	Reel Lift Assembly	1
8	323-6	Capscrew - Hex Hd.	2
9	3253-5	Lock Washer	2
10	3217-7	Hex Nut	2

Ref. No.	Part No.	Description	No. Used
11	48-005-0591	Reel Lift Tube Assembly	1
12	3256-6	Flat Washer	6
13	01-189-0813	Lock Nut	2
14	48-005-0231	Reel Lift Rod Assembly-L.H.	1
15	3217-11	Hex Nut	3
16	48-005-0222	Handle	1
17	323-11	Capscrew - Hex Hd.	1
18	01-261-0240	Spring	1
19	3256-4	Flat Washer	1
20	3218-3	Jam Nut	2

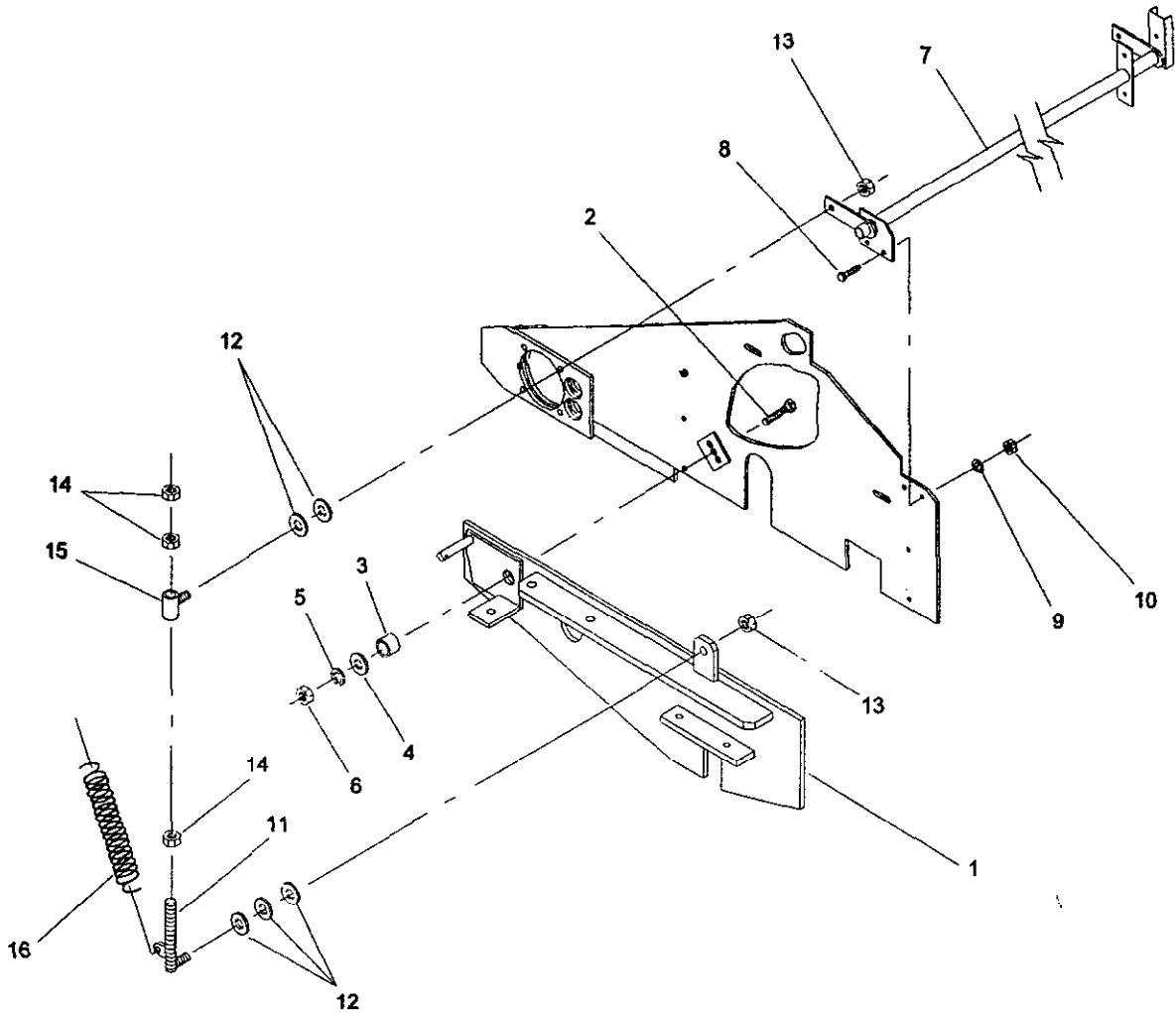

### REEL LIFT ASSEMBLY - R.H.

48-011

Ref. No.	Part No.	Description	No. Used
1	48-005-0172	Reel Plate Assembly-R.H.	1
2	327-6	Capscrew - Hex Hd.	1
3	48-004-5841	Reel Plate Spacer	1
4	3256-27	"SAE" Flat Washer	1
5	3253-8	Lock Washer	1
6	3218-6	Jam Nut	1
7	48-005-0432	Reel Lift Assembly	1
8	323-6	Capscrew - Hex Hd.	2

Ref. No.	Part No.	Description	No. Used
9	3253-5	Lock Washer	2
10	3217-7	Hex Nut	2
11	48-005-5781	Reel Lift Rod Assembly-R.H.	1
12	3256-6	Flat Washer	5
13	01-189-0813	Lock Nut	2
14	3217-11	Hex Nut	3
15	48-005-0591	Reel Lift Tube Assembly	1
16	01-261-0340	Spring	1

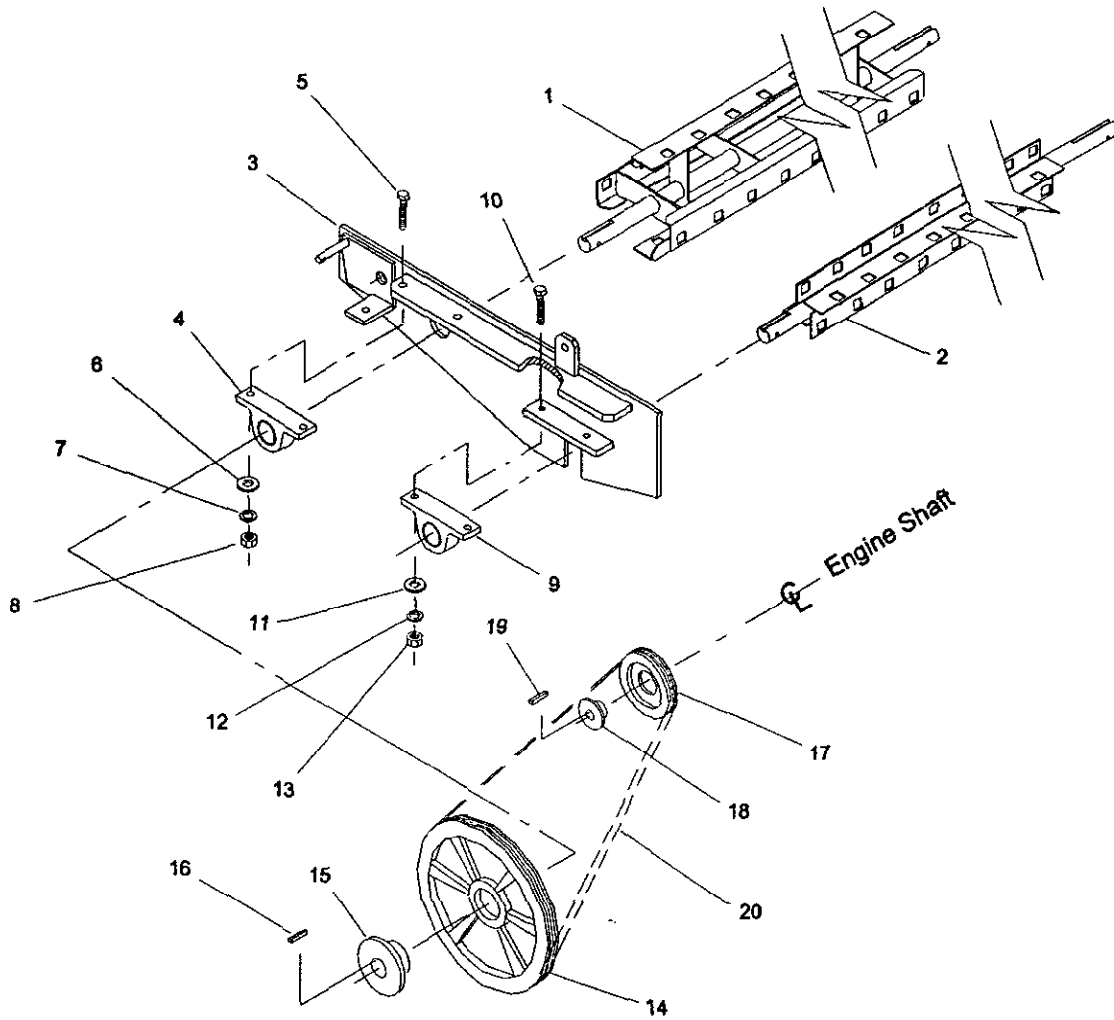

## BELT DRIVE ASSEMBLY

48-012

Ref. No.	Part No.	Description	No. Used
1	48-005-0201	Rear Reel Assembly	1
2	48-005-0131	Front Reel Assembly	1
3	48-005-0172	Reel Plate Assembly-R.H.	1
4	01-113-0020	Bearing	1
5	325-7	Capscrew - Hex Hd.	2
6	3256-26	"SAE" Flat Washer	2
7	3253-7	Lock Washer	2
8	3217-9	Hex Nut	2
9	01-113-0010	Bearing	1
10	323-8	Capscrew - Hex Hd.	2
11	3256-24	"SAE" Flat Washer	2
12	3253-5	Lock Washer	2

Ref. No.	Part No.	Description	No. Used
13	3217-7	Hex Nut	2
14	01-260-0010	Sheave	1
15	01-260-0290	Bushing	1
16	66-004-3211	Key	1
17	01-260-0110	Sheave	1
18	01-260-0780	Bushing (Onan)	1
*	01-260-0280	Bushing (B & S)	1
19	82-004-1171	Key	1
20	01-264-0010	Belt	1

\* Not Illustrated

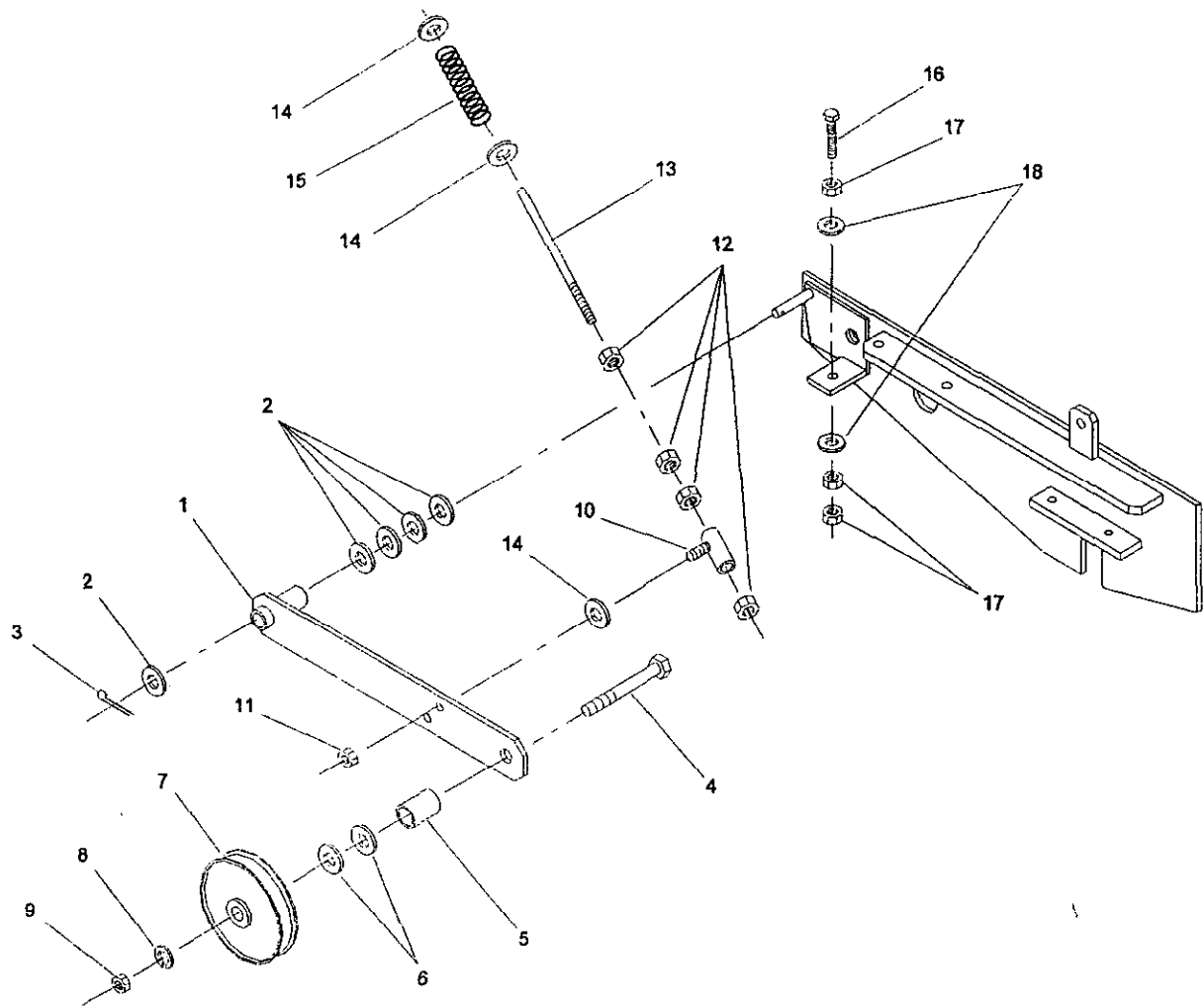

## BELT IDLER ASSEMBLY

48-018

Ref. No.	Part No.	Description	No. Used
1	48-005-0611	Idler Arm	1
2	01-168-1014	Machinery Bushing	5
3	3272-21	Cotter Pin	1
4	327-14	Capscrew - Hex Hd.	1
5	48-004-3471	Spacer	1
6	3256-7	Flat Washer	3
7	01-268-0010	Pulley	1
8	3253-8	Lock Washer	1
9	3217-11	Hex Nut	1

Ref. No.	Part No.	Description	No. Used
10	48-005-0121	Spring Tension Adjustment	1
11	3296-39	Lock Nut	1
12	3217-7	Hex Nut	4
13	48-004-1711	Idler Spring Rod	1
14	3256-4	Flat Washer	3
15	01-261-0300	Spring	1
16	01-182-0832	Capscrew - Hex Hd.	1
17	3217-9	Hex Nut	3
18	3256-6	Flat Washer	2

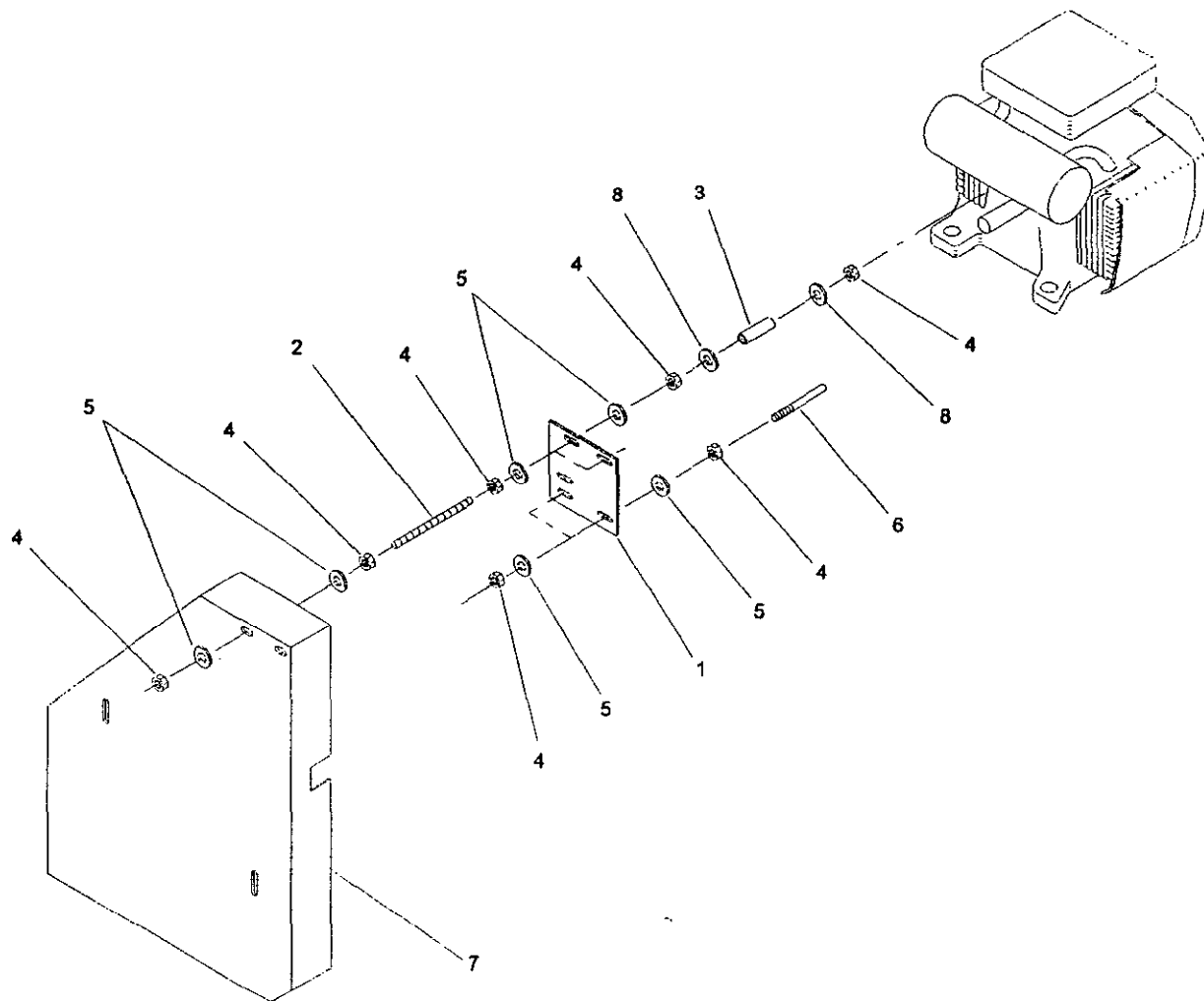

## BELT SLIP BRACKET

48-014

Ref. No.	Part No.	Description	No. Used
1	48-004-3291	Belt Slip Bracket	1
2	01-650-0160	All Thread (Onan)	2
*	01-650-0140	All Thread (B & S)	2
3	48-004-6271	Spacer (Onan)	2
*	48-004-2101	Spacer (B & S)	2

Ref. No.	Part No.	Description	No. Used
4	3217-7	Hex Nut	14
5	3256-4	Flat Washer	12
6	48-004-1211	Belt Slip Pin	2
7	48-005-0322	Belt Guard	1
8	3256-24	"SAE" Flat Washer	4

\* Not illustrated

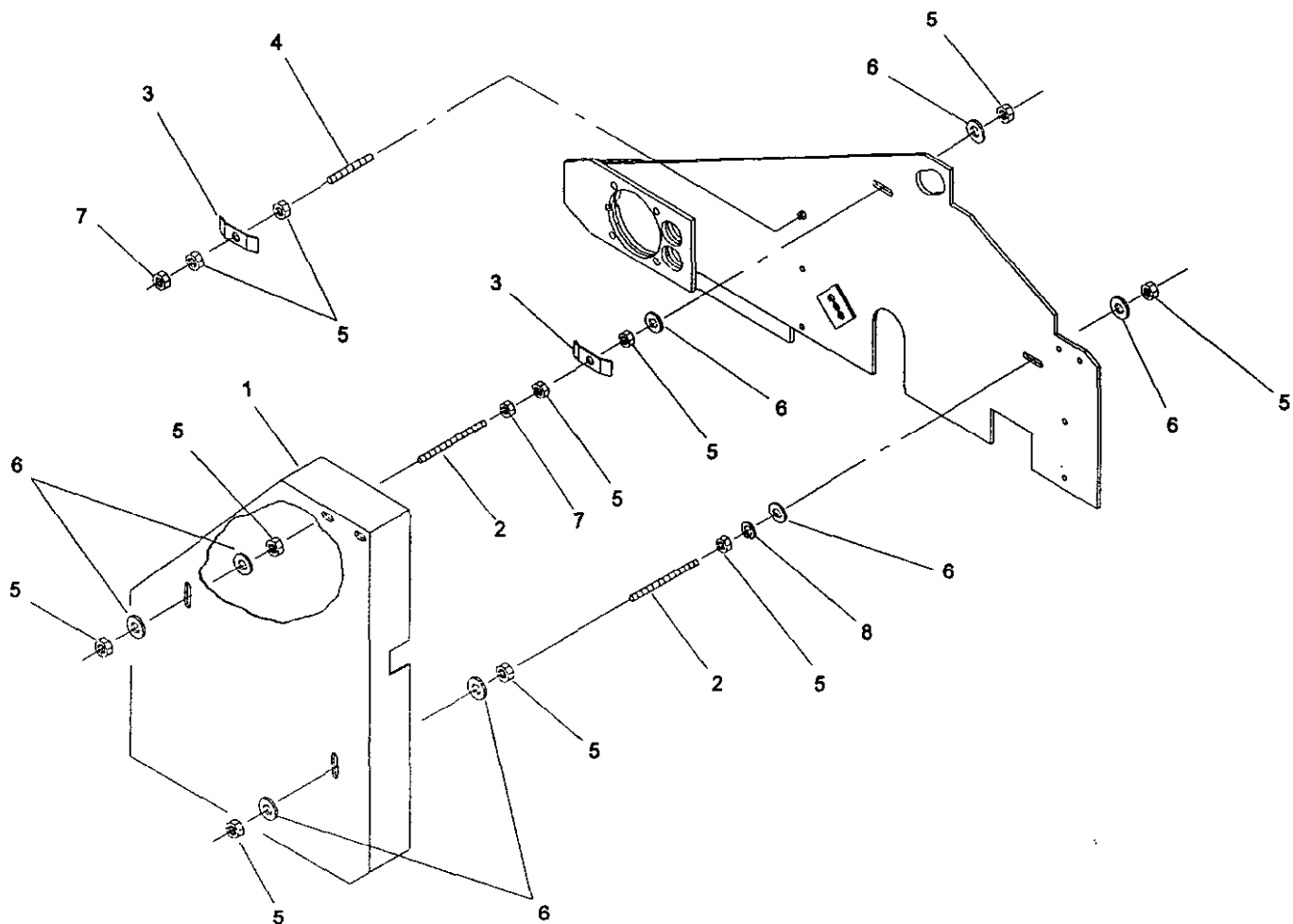

## BELT GUARD & HOSE BRACKETS

48-015

Ref. No.	Part No.	Description	No. Used
1	48-005-0322	Belt Guard	1
2	01-650-0420	All Thread	2
3	48-004-1861	Hose Hold Down Bracket	2
4	01-650-0280	All Thread	1

Ref. No.	Part No.	Description	No. Used
5	3217-8	Hex Nut	10
6	3256-5	Flat Washer	8
7	3218-4	Jam Nut	3
8	3253-6	Lock Washer	1

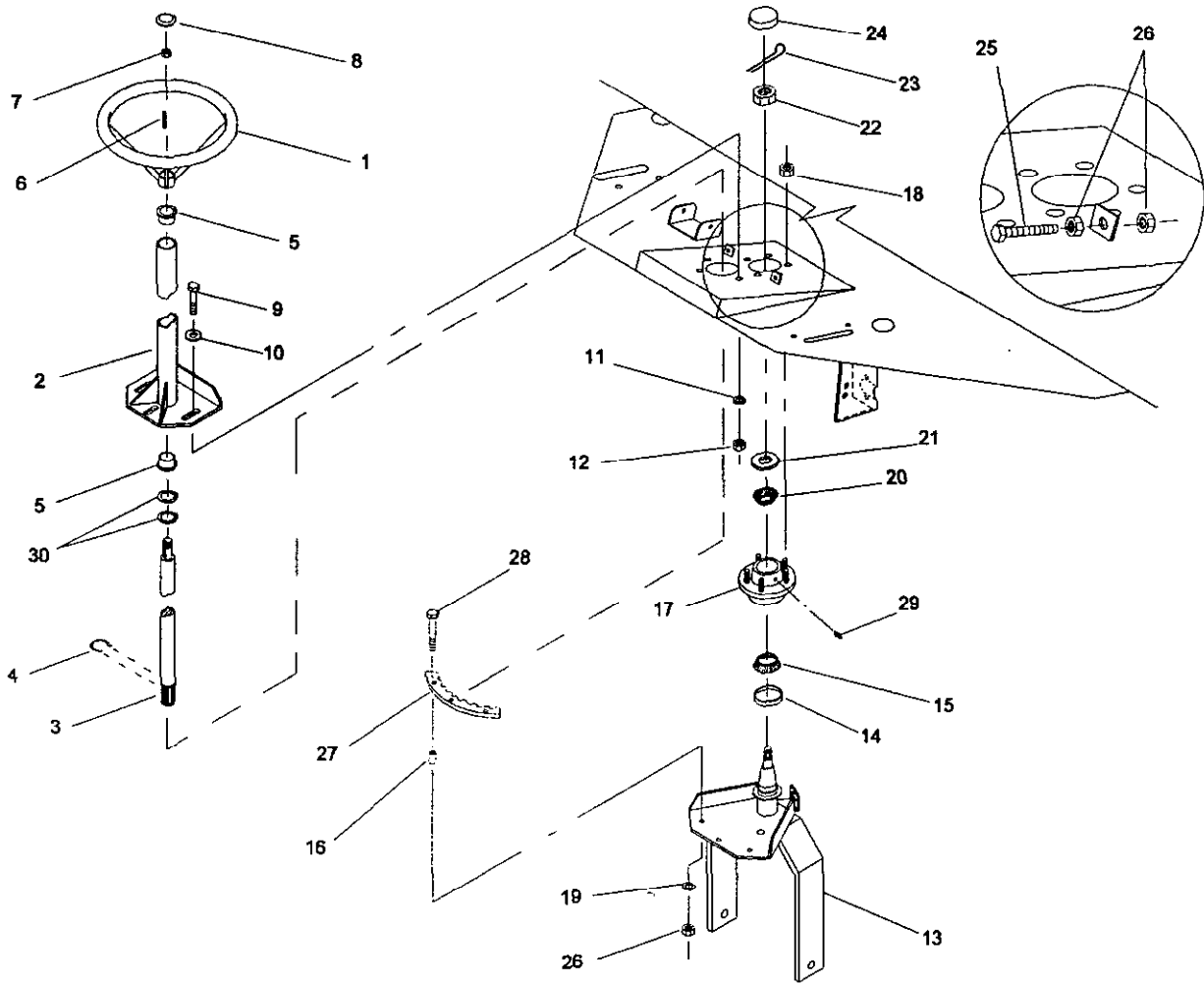

## STEERING ASSEMBLY

48-016

Ref. No.	Part No.	Description	No. Used
1	01-286-0130	Steering Wheel	1
2	54-005-1521	Steering Column Assembly	1
*	54-002-0011	Steering Column Assembly w/bushing (Incl. Ref. # 2,5)	1
3	54-004-1501	Steering Shaft	1
4	01-160-0410	Retaining Ring	1
5	01-126-0110	Bushing, Oilite	2
6	48-004-1961	Key	1
7	3220-7	Jam Nut	1
8	01-286-0030	Cover Plate	1
9	325-6	Capscrew - Hex Hd.	3
10	3256-6	Flat Washer	3
11	3253-7	Lock Washer	3
12	3217-9	Hex Nut	3
13	54-005-0242	Steering Yoke Assembly	1
14	01-405-0370	Seal	1
15	01-102-0050	Bearing	1

Ref. No.	Part No.	Description	No. Used
16	48-004-4651	Sector Spacer	3
17	01-269-0140	Steering Hub , complete (Incl. Ref. #14,15,18,20,24)	1
18	01-269-0300	Lug Nut	5
19	3253-5	Lock Washer	3
20	01-102-0070	Bearing	1
21	3256-28	"SAE" Flat Washer	1
22	01-190-1216	Castle Nut	1
23	3272-15	Cotter Pin	1
24	01-286-0040	Grease Cap	1
25	01-182-0620	Capscrew - Hex Hd.	2
26	3217-7	Hex Nut	7
27	48-004-1282	Steering Yoke Gear	1
28	323-11	Capscrew - Hex Hd.	3
29	01-215-0050	Grease Fitting	1
30	01-168-2010	Machinery Bushing	2

\* Not Illustrated

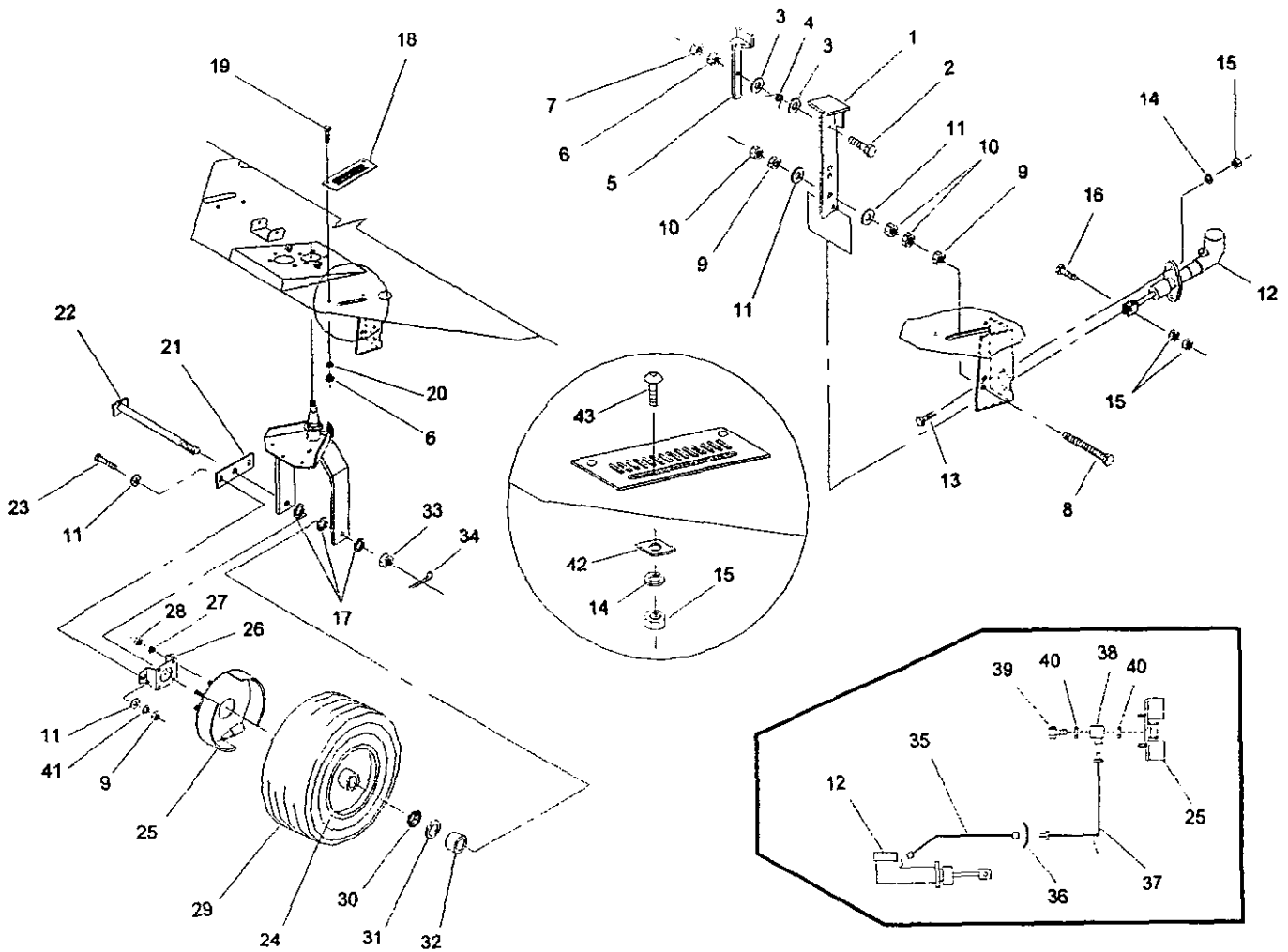

## BRAKE SYSTEM

48-017

Ref. No.	Part No.	Description	No. Used
1	48-005-0671	Brake Pedal	1
2	323-9	Capscrew - Hex Hd.	1
3	3256-4	Flat Washer	2
4	01-261-0050	Spring	1
5	48-005-0781	Brake Stop Weldment	1
6	3217-7	Hex Nut	3
7	3218-3	Jam Nut	1
8	01-182-0824	Capscrew - Hex Hd.	1
9	3217-9	Hex Nut	4
10	3218-5	Jam Nut	3
11	3256-6	Flat Washer	6
12	01-314-0290	Hydraulic Brake Cylinder	1
13	322-6	Capscrew - Hex Hd.	2
14	3253-4	Lock Washer	3
15	3217-6	Hex Nut	5
16	322-5	Capscrew - Hex Hd.	1
17	01-168-1210	Machinery Bushing	3
18	48-004-6241	Brake Stop Plate	1
19	323-6	Capscrew - Hex Hd.	2
20	3253-5	Lock Washer	2
21	54-005-0261	Brake Mount	1
22	54-005-0251	Axle	1
23	325-6	Capscrew - Hex Hd.	2
24	54-005-0282	Front Wheel	1
25	01-314-0300	Hydraulic Brake Assembly	1
*	01-266-0080	Wheel Cylinder Assembly	1
*	01-314-0500	Wheel Cylinder Repair Kit	1

Ref. No.	Part No.	Description	No. Used
*	01-314-0540	Capscrew - Socket Hd.	2
*	01-314-0430	Brake Shoe	2
*	01-314-0470	Brake Shoe Lever	2
*	01-314-0480	Brake Shoe Spring	2
*	01-314-0460	Anchor Pin	2
*	01-160-0380	Retaining Ring	2
*	01-314-0490	Adjusting Screw Assembly	2
*	01-314-0550	Shoulder Bolt	4
26	54-004-1241	Brake Shoe Bracket	1
27	3253-6	Lock Washer	4
28	3217-8	Hex Nut	4
29	01-269-0320	Front Tire	1
30	254-78	Bearing	2
31	01-405-0460	Seal	2
32	01-269-0060	Axle Spacer	2
33	01-190-1210	Castle Nut	1
34	3272-23	Cotter Pin	1
35	01-314-0020	Hydraulic Brake Hose	1
36	01-314-0070	Brake Line Clip	1
37	01-314-0330	Hydraulic Brake Line	1
38	01-314-0360	Connector	1
39	01-314-0340	Bolt	1
40	01-314-0350	Gasket	2
41	3253-7	Lock Washer	2
42	48-004-6631	Break Pedal Stop	1
43	3230-2	Carriage Bolt	1

\* Not Illustrated

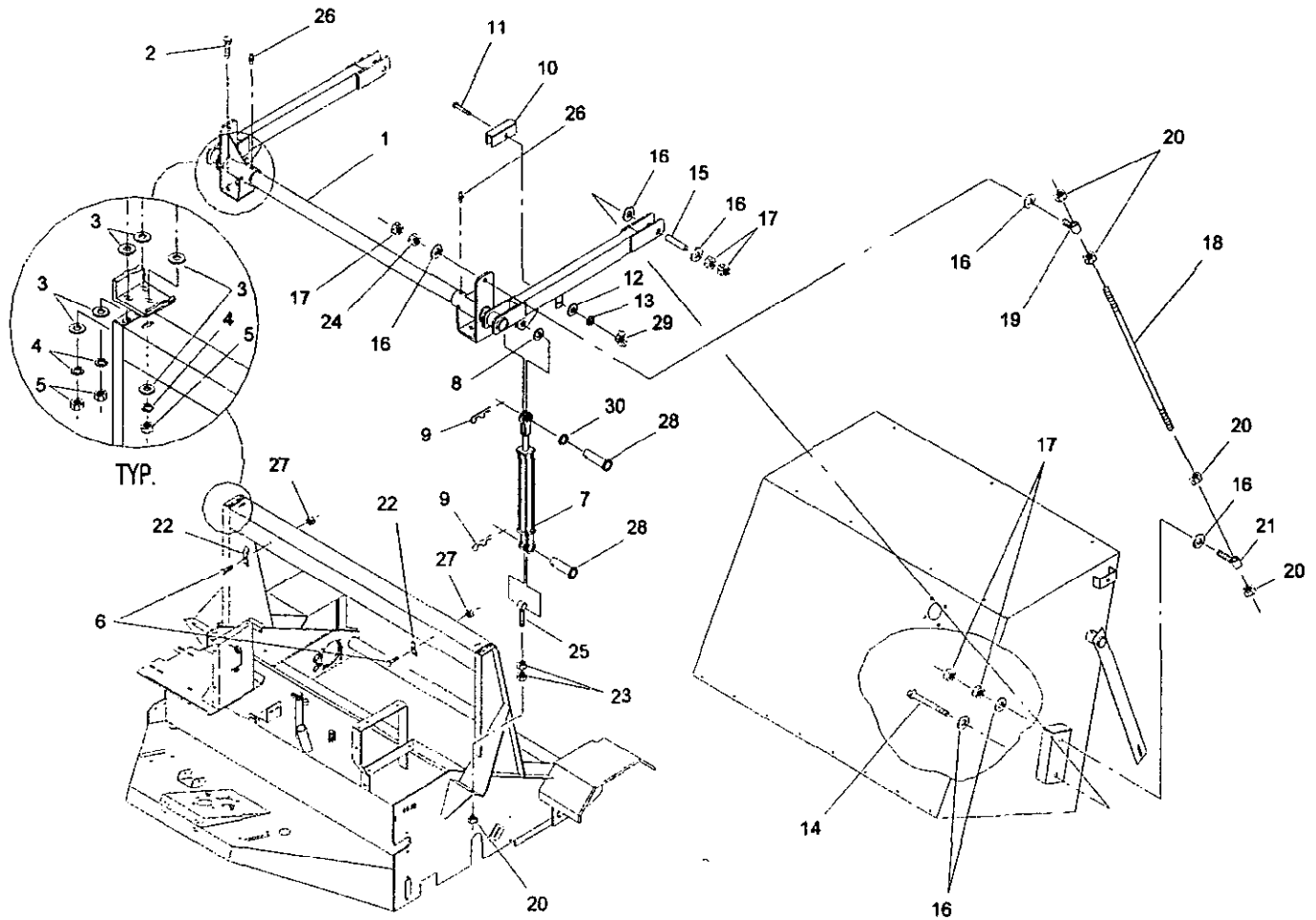

## HOPPER LIFT ARM ASSEMBLY

48HL-018

Ref. No.	Part No.	Description	No. Used
1	48-005-0352	Main Lift Arm	1
2	325-6	Capscrew - Hex Hd.	6
3	3256-26	"SAE" Flat Washer	12
4	3253-7	Lock Washer	6
5	3217-9	Hex Nut	6
6	323-9	Capscrew - Hex Hd.	8
7	01-301-0540	Cylinder (Incl. Ref. #28)	1
*	01-301-0570	Seal Kit	1
8	01-168-1610	Machinery Bushing	1
9	01-159-0010	Presto Pin	4
10	48-005-0561	Cylinder Safety Stop	1
11	3231-10	Carriage Bolt	1
12	3256-4	Flat Washer	1
13	3253-5	Lock Washer	7
14	328-23	Capscrew - Hex Hd.	2
15	48-004-3441	Spacer	2

Ref. No.	Part No.	Description	No. Used
16	01-166-1200	Flat Washer	12
17	3218-7	Jam Nut	10
18	48-004-3052	Upper Arm	2
19	48-005-0381	Upper Pivot Arm Bracket	2
20	3219-9	Hex Nut	9
21	48-005-0371	Lower Pivot Assembly	2
22	48-004-4831	Hose Bracket	2
23	01-191-1614	Jam Nut	2
24	3217-12	Hex Nut	2
25	48-005-0571	Cylinder Adj. Pivot	1
26	01-215-0050	Grease Fitting	4
27	3296-39	Lock Nut	2
28	01-252-0150	Clevis Pin	2
29	32103-3	Wing Nut	1
30	01-168-1614	Machinery Bushing	1(var)

\* Not Illustrated

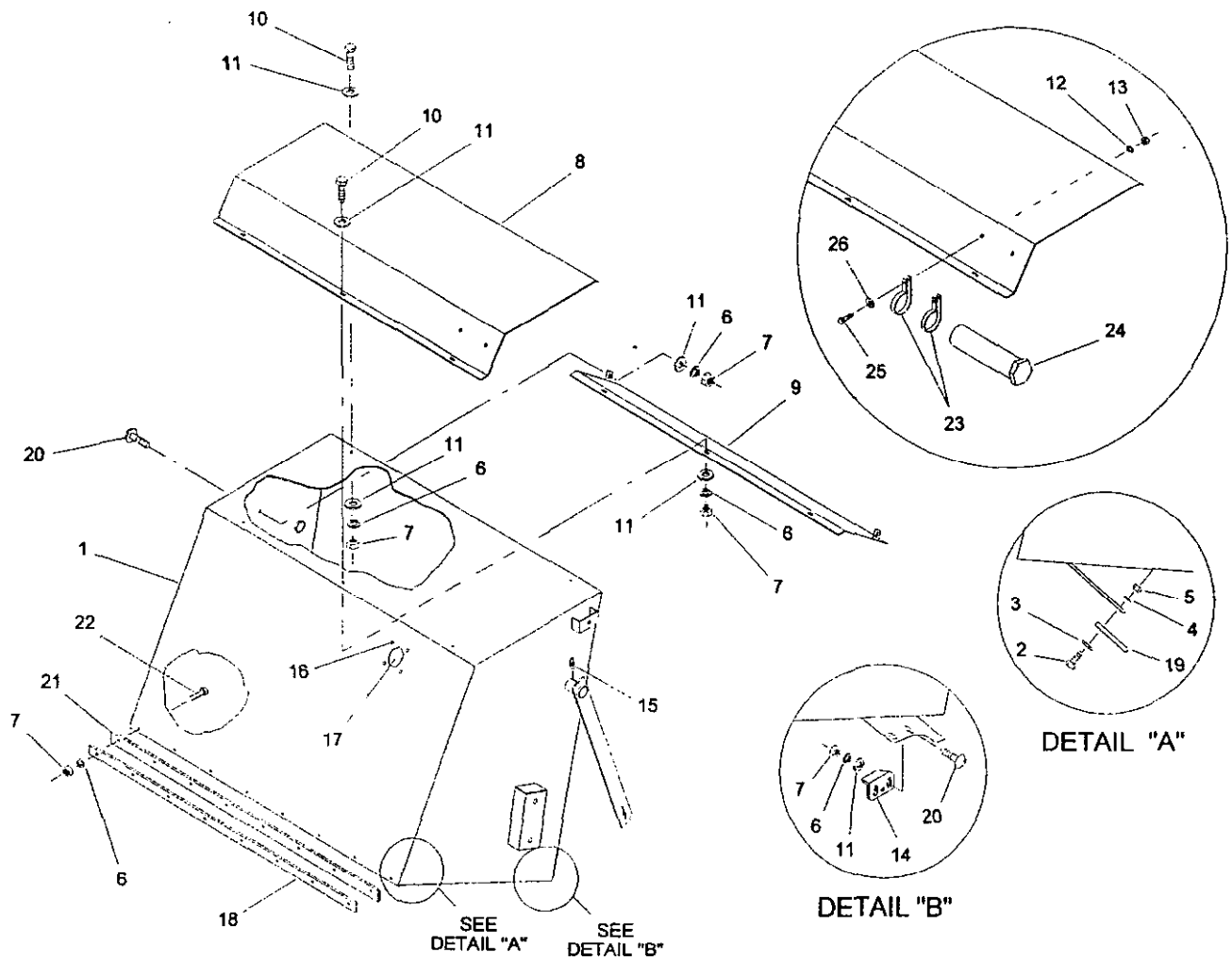

## HOPPER ASSEMBLY

48HL-019

Ref. No.	Part No.	Description	No. Used
1	48-005-0513	Hopper	1
2	322-3	Capscrew - Hex Hd.	8
3	3256-3	Flat Washer	8
4	3253-4	Lock Washer	8
5	3217-6	Hex Nut	8
6	3253-5	Lock Washer	19
7	3217-7	Hex Nut	19
8	48-005-0292	Dust Shield Assembly	1
9	48-004-6282	Wet Leaf Deflector	1
10	01-184-0610	Machine Screw - Rd. Hd.	5
11	3256-4	Flat Washer	16
12	3253-3	Lock Washer	2
13	3217-5	Hex Nut	2
14	48-004-4461	Hopper Pivot Adj. Bracket-RH	1

Ref. No.	Part No.	Description	No. Used
*	48-004-6591	Hopper Pivot Adj. Bracket-LH	1
15	01-215-0050	Grease Fitting	2
16	01-161-0030	Pop Rivet	4
17	48-004-4641	Peep Hole Cover	1
18	48-004-6161	Rubber Flap Mount	1
19	48-004-5451	Hopper Floor Seal	1
20	3231-2	Carriage Bolt	6
21	48-004-6191	Hopper Flap	1
22	323-7	Capscrew - Hex Hd.	8
23	2412-133	R-Clamp	2
24	74-0720	Manual Tube	1
25	321-4	Capscrew - Hex Hd.	2
26	3256-2	Flat Washer	2

\* Not Illustrated

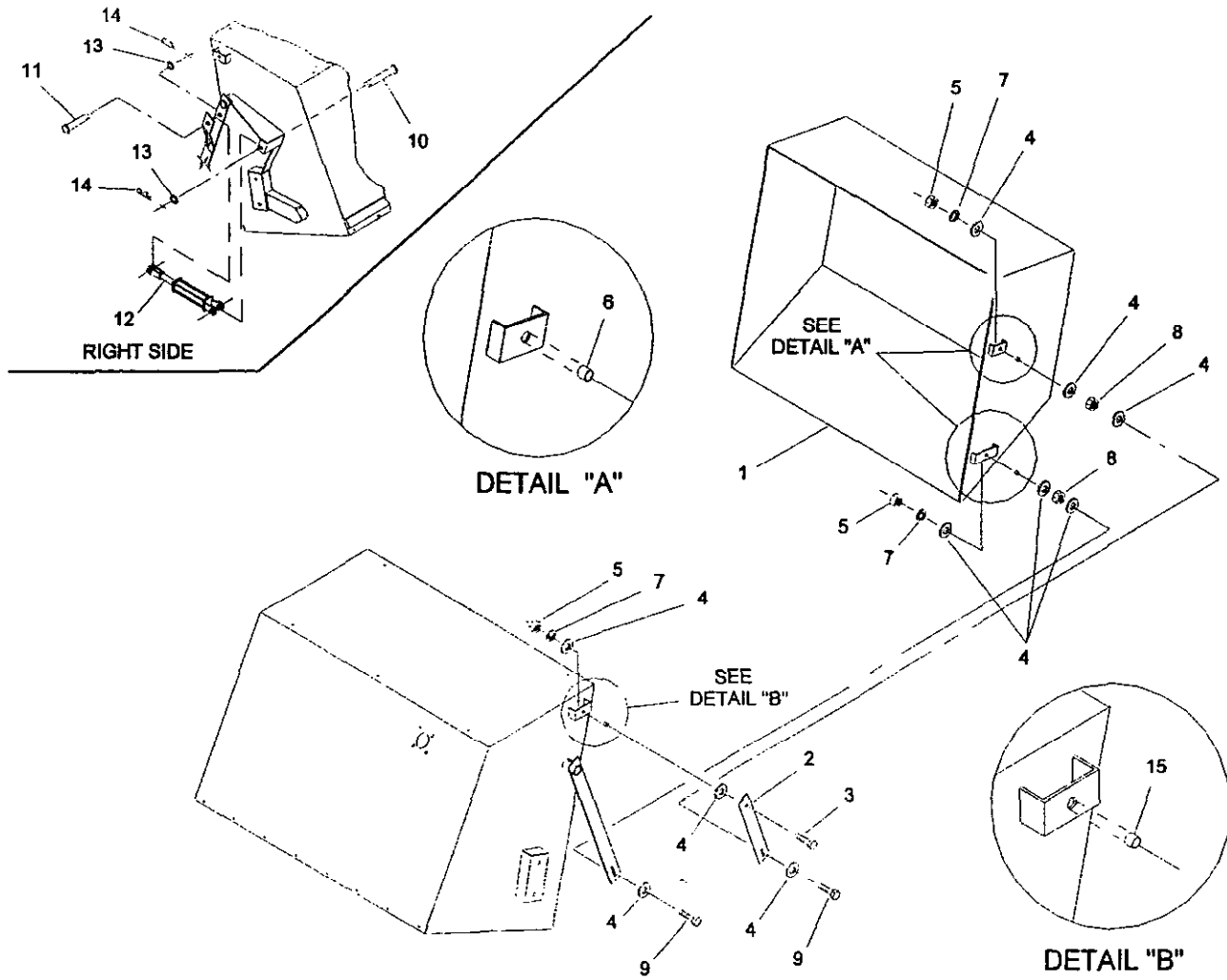

## HOPPER DOOR ASSEMBLY

48HL-022

Ref. No.	Part No.	Description	No. Used
1	48-005-0602	High Lift Hopper Door	1
2	48-004-3001	Door Linkage-Upper	2
3	325-7	Capscrew - Hex Hd.	2
4	3256-6	Flat Washer	20
5	3217-9	Hex Nut	6
6	48-004-6101	Hopper Box Spacer	4
7	3253-7	Lock Washer	6
8	3218-5	Jam Nut	4

Ref. No.	Part No.	Description	No. Used
9	325-8	Capscrew - Hex Hd.	4
10	48-005-0341	Hopper Door Cyl. Pin-lower	1
11	48-005-0331	Hopper Door Cyl. Pin-upper	1
12	01-301-0550	Cylinder	1
*	01-301-0570	Seal Kit	1
13	3256-42	Flat Washer	2
14	01-159-0010	Presto Pin	2
15	48-004-6311	Hopper Box Spacer	2

\* Not Illustrated

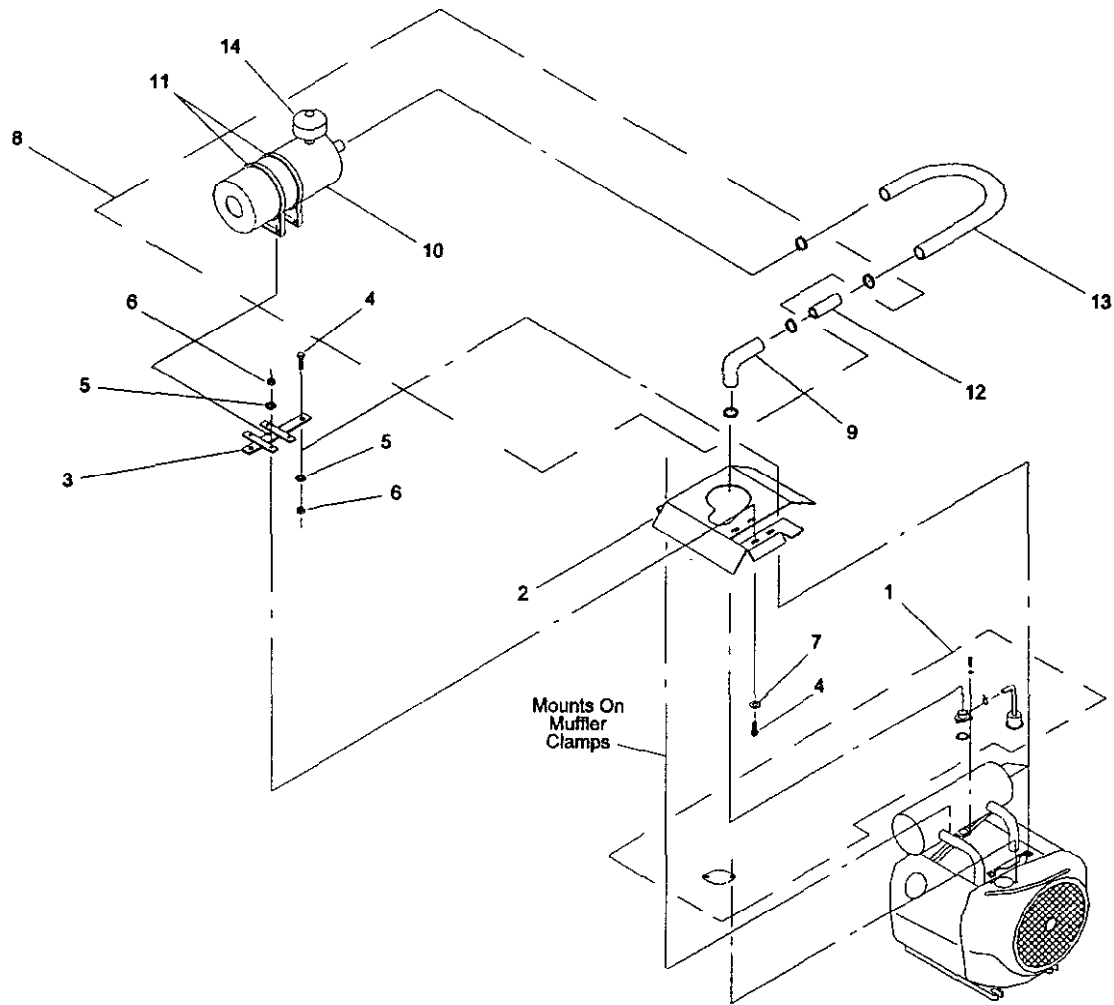

## DONALDSON AIR CLEANER - MODEL NO. 44062

48-020

Ref. No.	Part No.	Description	No. Used
1	01-289-0330	Adaptor Kit	1
2	48-004-6302	Air Cleaner Base	1
3	48-005-0791	Air Cleaner Mount	1
4	322-5	Capscrew - Hex Hd.	6
5	3253-4	Lock Washer	6
6	3217-6	Hex Nut	6
7	3256-3	Flat Washer	4
8	01-289-0280	Air Cleaner Kit	1
*	01-289-0470	Filter Element (Incl. w/Ref. #8)	1

Ref. No.	Part No.	Description	No. Used
9	01-289-0300	Air Cleaner-Elbow	1
10	01-289-0310	Air Cleaner (Incl. Ref. #11)	1
11	01-289-0320	Bands	1
12	93-004-0511	Spacer	1
13	54-004-1701	Hose	1
14	01-289-0290	Pre-cleaner	1

\*Not Illustrated

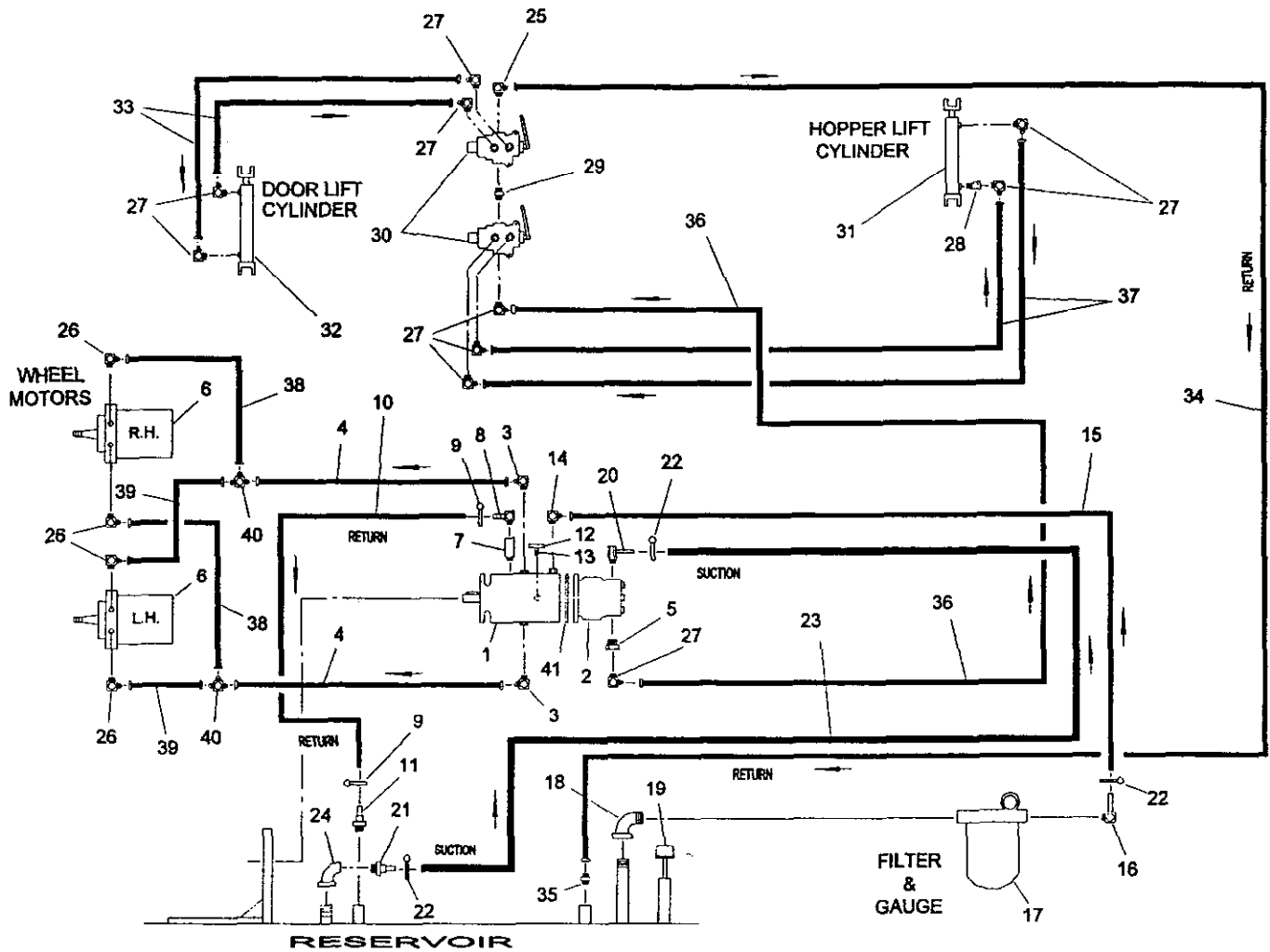

## HYDRAULIC SCHEMATIC - 4800HL

48HL-021

Ref. No.	Part No.	Description	No. Used
1	01-305-0090	Cessna Pump	1
*	01-305-0080	Seal Kit	1
2	01-305-0020	Sundstrand Pump	1
*	01-305-0600	Seal Kit	1
3	01-201-0440	Fitting	2
4	01-312-1260	Hose Assembly	2
5	01-201-0020	Fitting	1
6	01-304-0410	Hyd. Motor	2
*	01-304-0260	Seal Kit	1
7	01-201-0490	Fitting	1
8	01-217-0050	Hose Barb	1
9	01-202-0030	Hose Clamp	2
10	48-004-4921	Hose Assembly	1
11	01-217-0060	Hose Barb	1
12	48-005-0641	Tow Valve Handle	1
13	01-163-0100	Set Screw	1
14	01-201-1880	Fitting	1
15	01-312-1710	Hose Assembly	1
16	01-201-1890	Fitting	1
17	01-316-0020	Filter Assembly	1
*	01-315-0010	Filter Head	1
*	01-317-0240	Filter Element	1
*	01-303-0010	Filter Gauge	1
18	01-455-0020	Fitting	1
19	48-002-0101	Breather Cap w/dipstick	1

Ref. No.	Part No.	Description	No. Used
20	01-201-1080	Fitting	1
21	01-201-0750	Fitting	1
22	01-202-0050	Hose Clamp	3
23	48-004-4931	Hose Assembly	1
24	01-455-0080	Fitting	1
25	01-201-0530	Fitting	1
26	01-201-1580	Fitting	4
27	01-201-0190	Fitting	10
28	01-310-0040	Fitting	1
29	01-201-0160	Fitting	1
30	01-308-0050	Valve	2
*	01-308-0130	Seal Kit	1
31	01-301-0540	Cylinder	1
*	01-301-0570	Seal Kit	1
32	01-301-0550	Cylinder	1
*	01-301-0570	Seal Kit	1
33	01-312-0190	Hose Assembly	2
34	01-312-0840	Hose Assembly	1
35	01-201-0810	Fitting	1
36	01-312-0200	Hose Assembly	1
37	01-312-0280	Hose Assembly	2
38	01-312-1430	Hose Assembly	2
39	01-312-1420	Hose Assembly	2
40	01-201-1530	Fitting	2
41	01-402-0230	O-Ring	1

\* Not Illustrated

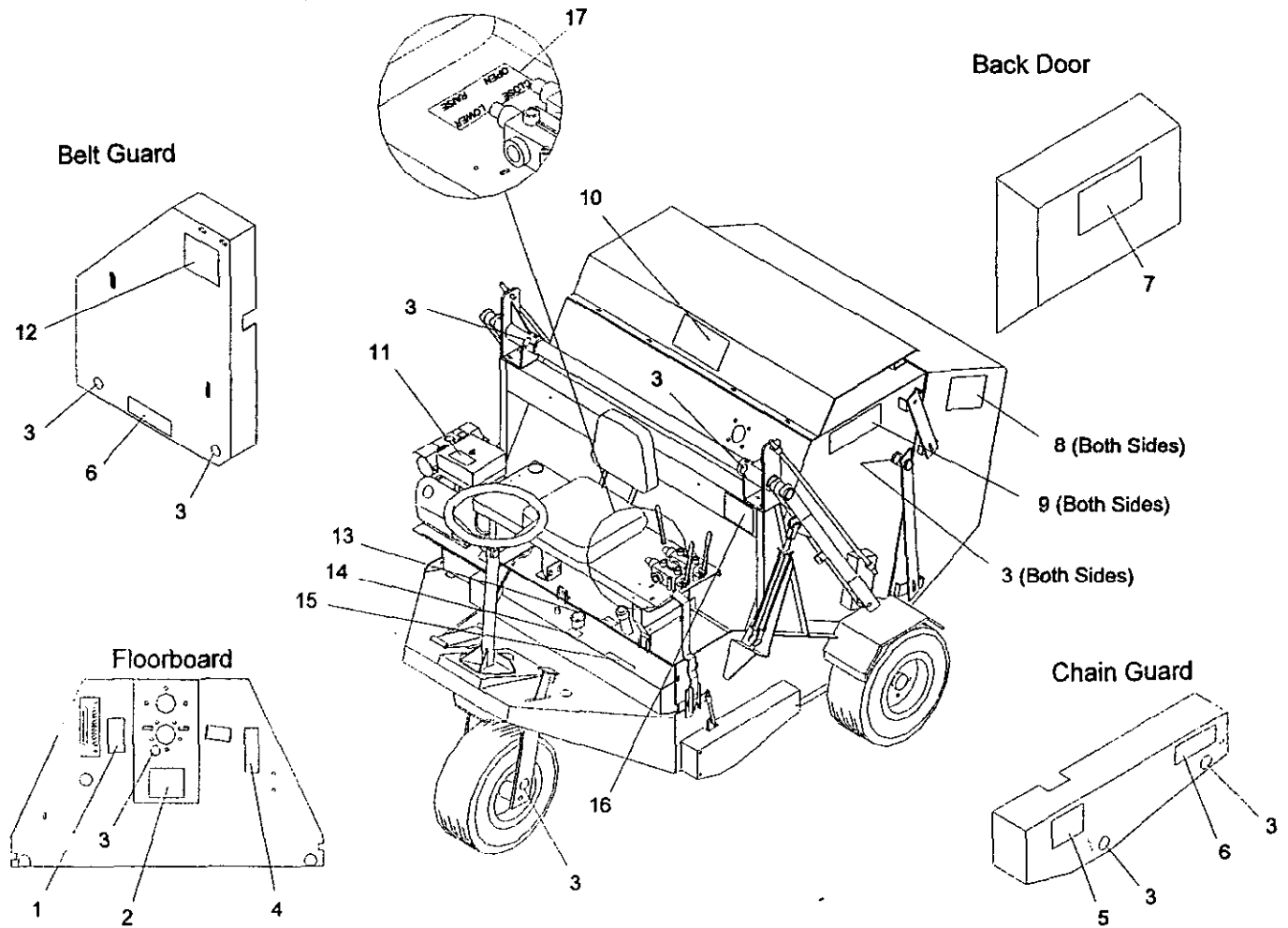

## DECALS

48HLDECL

Ref. No.	Part No.	Description	No. Used
1	01-506-0980	Decal - Parking Brake	1
2	01-506-0090	Decal - Danger	1
3	58-6520	Decal - Grease	10
4	01-506-0570	Decal - Traction Pedal	1
5	01-506-0050	Decal - Danger	1
6	01-506-0080	Decal - Danger	2
7	67-7920	Decal - Toro	1
8	01-506-0060	Decal - Danger	2
9	01-506-0720	Decal - Turf Sweeper 4800HL	2

Ref. No.	Part No.	Description	No. Used
10	66-6140	Decal - Toro	1
11	01-506-0030	Decal - Danger	1
12	01-506-0040	Decal - Danger	1
13	52-9640	Decal - Hydraulic Oil	1
14	71-3730	Decal - Gas Only	1
15	75-5190	Decal - No Riders	1
16	01-506-0070	Decal - Danger	1
17	01-506-0170	Decal - Hopper Door/ Hopper Lift	1

# CESSNA PUMP - NO. 01-305-0090

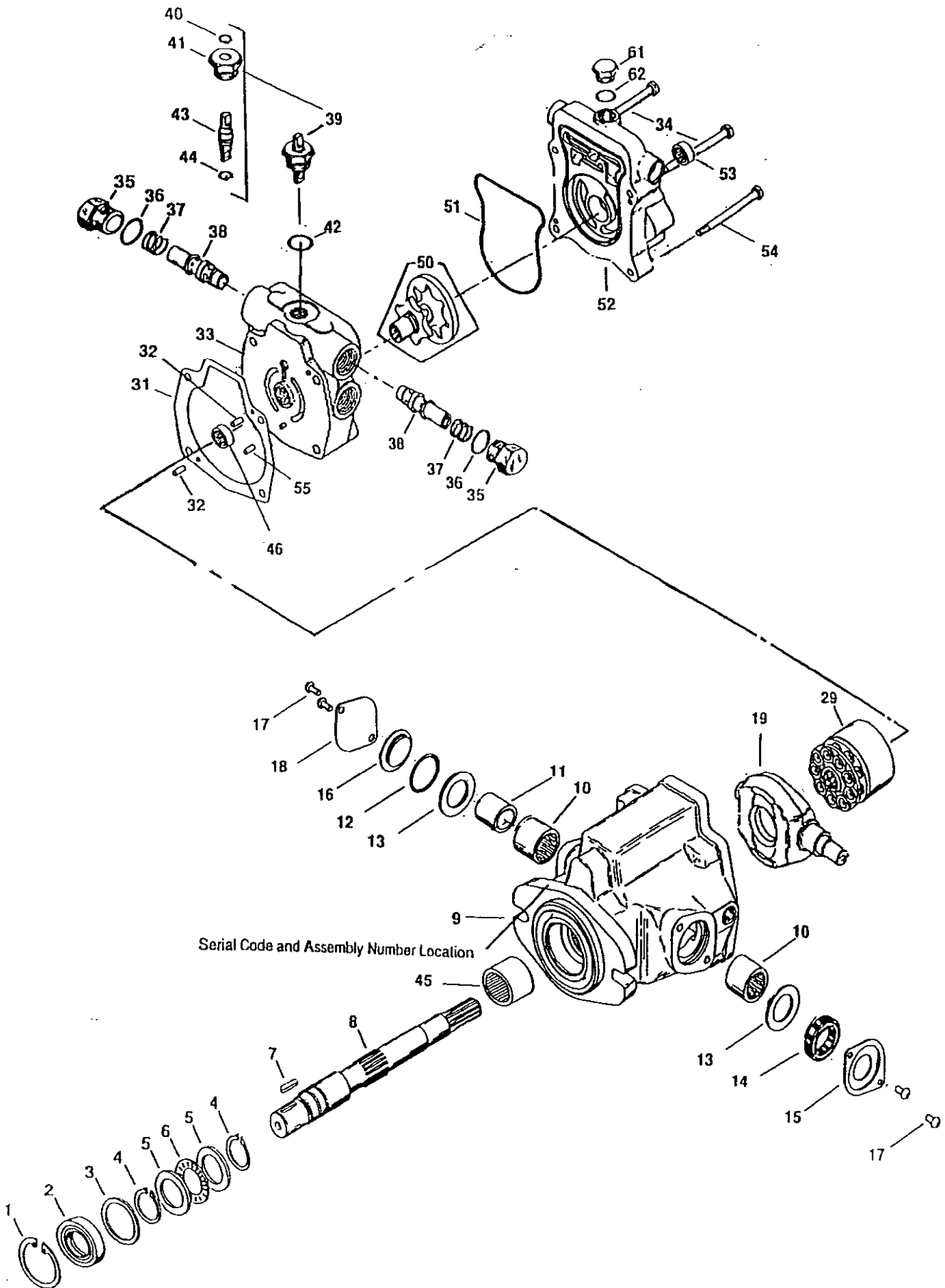

## CESSNA PUMP - NO. 01-305-0090

Ref. No.	Part No.	Description	No. Used
1		Retaining Ring	1
2	01-405-0400	Shaft Seal - Drive	1
3	92-4626	Washer	1
4		Retaining Ring	2
5	92-4629	Bearing Race	2
6	01-105-0490	Thrust Bearing	1
7	92-4641	Key - Drive Shaft	1
8	01-305-0120	Drive Shaft	1
9	92-4623	Housing Assembly	1
10	01-105-0460	Needle Bearing	2
11	01-105-0500	Inner Race	1
12		O-Ring	1
13	92-4631	Washer	2
14		Shaft Seal - Trunnion	1
15	92-4636	Seal Cover	1
16	92-4638	Cover - O-Ring	1
17	92-4633	Screw - Pan Head	4
18	92-4637	Trunnion Cover	1
19	92-4625	Camplate	1
20			
21			
22			
23			
24			
25			
26			
27			
28			
29	92-4624	Rotating Kit Assembly	1
30			
31	01-401-0010	Housing Gasket	1
32	01-153-0200	Dowel Pin	2
33	92-4622	Back Plate Assembly	1
34	92-4640	Capscrew	2
35	92-4634	Plug Assembly	2
36		O-Ring	2

Ref. No.	Part No.	Description	No. Used
37	01-305-1520	Spring	2
38	01-305-1530	Relief Valve	2
39	01-308-0180	Dump Valve Assembly	1
40		Retaining Ring	1
41		Separator Plug	1
42		O-Ring	1
43	01-318-0090	Separator	1
44		O-Ring	1
45	01-105-0320	Bearing	1
46	01-105-0470	Bearing	1
47			
48			
49			
50	01-254-0060	Gerator & Coupler Assembly	1
51		Molded O-Ring	1
52	92-4646	Charge Pump Adaptor	1
53	01-105-0480	Bearing	1
54	92-4639	Capscrew	2
55	92-4649	Roll Pin	1
56			
57			
58			
59			
60			
61	92-4643	Plug Assembly	1
62		O-Ring	1
	* 01-305-1500	Relief Valve Ass'y (Incl. Ref. #35,37,38)	2
	* 92-4650	Seal Kit (Incl. Ref. #1,2,4,12,14,31, 36,40,42,44,51,62)	1

\* Not illustrated

# PART NUMBER INDEX

Part No.	Description	Pg. No.	Ref. No.	Qty.	Part No.	Description	Pg. No.	Ref. No.	Qty.
01-102-0050	Bearing	16	15	1	01-201-0160	Fitting	22	29	1
01-102-0070	Bearing	16	20	1	01-201-0190	Fitting	22	27	10
01-105-0320	Bearing	25	45	1	01-201-0440	Fitting	22	3	2
01-105-0460	Needle Bearing	25	10	2	01-201-0490	Fitting	22	7	1
01-105-0470	Bearing	25	46	1	01-201-0530	Fitting	22	25	1
01-105-0480	Bearing	25	53	1	01-201-0750	Fitting	22	21	1
01-105-0490	Thrust Bearing	25	6	1	01-201-0810	Fitting	22	35	1
01-105-0500	Inner Race	25	11	1	01-201-1080	Fitting	22	20	1
01-105-0520	Needle Bearing	8	26	2	01-201-1530	Fitting	22	40	2
01-105-0520	Needle Bearing	9	16	2	01-201-1580	Fitting	22	26	4
01-113-0010	Bearing	12	9	1	01-201-1880	Fitting	22	14	1
01-113-0010	Bearing	8	15	1	01-201-1890	Fitting	22	16	1
01-113-0020	Bearing	12	4	1	01-202-0030	Hose Clamp	22	9	2
01-113-0020	Bearing	8	5	1	01-202-0030	Hose Clamp	6	5	2
01-126-0110	Bushing, Oilite	16	5	2	01-202-0050	Hose Clamp	22	22	3
01-127-0070	Plastic Plug	1	*	1	01-215-0050	Grease Fitting	16	29	1
01-151-0170	Cotter Pin	1	21	2	01-215-0050	Grease Fitting	18	26	4
01-153-0200	Dowel Pin	25	32	2	01-215-0050	Grease Fitting	19	15	2
01-158-0150	Capscrew - Socket Hd.	4	23	10	01-217-0050	Hose Barb	22	8	1
01-158-0150	Capscrew - Socket Hd.	5	23	8	01-217-0060	Hose Barb	22	11	1
01-158-0270	Shoulder Bolt	7	2	2	01-217-0060	Hose Barb	6	4	1
01-158-2040	Lug Bolt	1	24	10	01-250-0020	Rod End Bearing	9	8	1
01-159-0010	Presto Pin	18	9	4	01-250-0020	Rod End Bearing	7	7	1
01-159-0010	Presto Pin	20	14	2	01-251-0020	Offset Link	8	*	1
01-160-0380	Retaining Ring	17	*	2	01-252-0150	Clevis Pin	18	28	2
01-160-0410	Retaining Ring	16	4	1	01-254-0060	Gerator & Coupler Assembly	25	50	1
01-161-0030	Pop Rivet	19	16	4	01-256-0020	Throttle Handle	4	*	1
01-163-0100	Set Screw	22	13	1	01-260-0010	Sheave	12	14	1
01-163-0100	Set Screw	4	*	1	01-260-0110	Sheave	12	17	1
01-163-0100	Set Screw	5	*	1	01-260-0280	Bushing	12	*	1
01-166-1200	Flat Washer	18	16	12	01-260-0290	Bushing	12	15	1
01-168-1014	Machinery Bushing	13	2	5	01-260-0780	Bushing	12	18	1
01-168-1210	Machinery Bushing	17	17	3	01-260-0900	"H" Bushing	4	24	1
01-168-1410	Machinery Bushing	9	13	11	01-260-0900	"H" Bushing	5	24	1
01-168-1410	Machinery Bushing	8	23	6	01-261-0050	Spring	17	4	1
01-168-1414	Machinery Bushing	9	14	5	01-261-0240	Spring	1	4	4
01-168-1414	Machinery Bushing	9	24	4	01-261-0240	Spring	10	18	1
01-168-1610	Machinery Bushing	18	8	1	01-261-0300	Spring	9	12	1
01-168-1610	Machinery Bushing	8	20	3	01-261-0300	Spring	13	15	1
01-168-1614	Machinery Bushing	18	30	1	01-261-0330	Spring	7	12	1
01-168-1614	Machinery Bushing	8	21	6	01-261-0340	Spring	11	16	1
01-168-2010	Machinery Bushing	16	30	2	01-261-0930	Spring	7	13	1
01-168-2010	Machinery Bushing	8	13	2	01-262-0040	Sprocket	8	11	1
01-168-2014	Machinery Bushing	8	10	3	01-262-0050	Sprocket	8	22	1
01-169-0010	Lock Washer	4	22	10	01-262-0610	Sprocket	9	15	1
01-169-0010	Lock Washer	5	22	8	01-262-0610	Sprocket	8	25	1
01-169-0070	Washer	3	16	1	01-264-0010	Belt	12	20	1
01-170-0160	Clamp	5	5	1	01-265-0180	Flex Coupling	4	21	1
01-182-0616	Capscrew - Hex Hd.	1	7	4	01-265-0180	Flex Coupling	5	21	1
01-182-0620	Capscrew - Hex Hd.	16	25	2	01-266-0080	Wheel Cylinder Assembly	17	*	1
01-182-0824	Capscrew - Hex Hd.	17	8	1	01-268-0010	Pulley	13	7	1
01-182-0832	Capscrew - Hex Hd.	13	16	1	01-269-0060	Axle Spacer	17	32	2
01-184-0610	Machine Screw - Rd. Hd.	19	10	7	01-269-0140	Steering Hub	16	17	1
01-189-0518	Lock Nut	7	4	2	01-269-0300	Lug Nut	16	18	5
01-189-0813	Lock Nut	10	13	2	01-269-0320	Front Tire	17	29	1
01-189-0813	Lock Nut	11	13	2	01-269-0330	Tire	1	23	2
01-190-1210	Castle Nut	17	33	1	01-269-1020	Wheel	1	22	2
01-190-1216	Castle Nut	16	22	1	01-269-2540	Wheel Hub	1	20	2
01-190-1620	Castle Nut	1	26	2	01-270-1370	Engine	5	1	1
01-190-1620	Castle Nut	2	22	1	01-270-1640	Engine	4	1	1
01-191-1614	Jam Nut	18	23	2	01-273-0240	Muffler Kit	5	2	1
01-201-0020	Fitting	22	5	1					

\* Not Illustrated

# PART NUMBER INDEX (Continued)

Part No.	Description	Pg. No.	Ref. No.	Qty.	Part No.	Description	Pg. No.	Ref. No.	Qty.
01-273-0250	Muffler Tube Kit	5	32	1	01-308-0130	Seal Kit	22	*	1
01-273-0310	Exhaust Extension	5	4	1	01-308-0130	Valve Repair Kit	3	*	1
01-279-0010	Rubber Fingers	8	3	116	01-308-0140	Spring Centered Assembly Kit	3	*	1
01-280-0020	Gas Cap	6	2	1	01-308-0150	Detent Kit	3	*	1
01-280-0190	Tank Withdrawal Assembly	6	3	1	01-308-0180	Dump Valve Assembly	25	39	1
01-286-0030	Cover Plate	16	8	1	01-308-0190	Lever	3	5	1
01-286-0040	Grease Cap	16	24	1	01-308-1750	Pin	3	7	2
01-286-0130	Steering Wheel	16	1	1	01-310-0040	Fitting	22	28	1
01-286-0220	Seat	1	6	1	01-312-0190	Hose Assembly	22	33	2
01-288-0020	Hour Meter	1	25	1	01-312-0200	Hose Assembly	22	36	1
01-289-0280	Air Cleaner Kit	21	8	1	01-312-0280	Hose Assembly	22	37	2
01-289-0290	Pre-cleaner	21	14	1	01-312-0840	Hose Assembly	22	34	1
01-289-0300	Air Cleaner-Elbow	21	9	1	01-312-1260	Hose Assembly	22	4	2
01-289-0310	Air Cleaner	21	10	1	01-312-1420	Hose Assembly	22	39	2
01-289-0320	Bands	21	11	1	01-312-1430	Hose Assembly	22	38	2
01-289-0330	Adaptor Kit	21	1	1	01-312-1710	Hose Assembly	22	15	1
01-289-0470	Filter Element	21	*	1	01-314-0020	Hydraulic Brake Hose	17	35	1
01-301-0540	Cylinder	18	7	1	01-314-0070	Brake Line Clip	17	36	1
01-301-0540	Cylinder	22	31	1	01-314-0290	Hydraulic Brake Cylinder	17	12	1
01-301-0550	Cylinder	20	12	1	01-314-0300	Hydraulic Brake Assembly	17	25	1
01-301-0550	Cylinder	22	32	1	01-314-0330	Hydraulic Brake Line	17	37	1
01-301-0570	Seal Kit	18	*	1	01-314-0340	Bolt	17	39	1
01-301-0570	Seal Kit	20	*	1	01-314-0350	Gasket	17	40	2
01-301-0570	Seal Kit	22	*	1	01-314-0360	Connector	17	38	1
01-303-0010	Filter Gauge	22	*	1	01-314-0430	Brake Shoe	17	*	2
01-304-0260	Seal Kit	1	*	1	01-314-0460	Anchor Pin	17	*	2
01-304-0260	Seal Kit	22	*	1	01-314-0470	Brake Shoe Lever	17	*	2
01-304-0260	Seal Kit	2	*	1	01-314-0480	Brake Shoe Spring	17	*	2
01-304-0410	Hyd. Motor	22	6	2	01-314-0490	Adjusting Screw Assembly	17	*	2
01-304-0410	Hydraulic Motor	1	14	2	01-314-0500	Wheel Cylinder Repair Kit	17	*	1
01-304-0490	Shaft	2	26	1	01-314-0540	Capscrew - Socket Hd.	17	*	2
01-304-0660	Thrust Bearing	2	12	2	01-314-0550	Shoulder Bolt	17	*	4
01-304-0840	Housing Kit	2	*	1	01-315-0010	Filter Head	22	*	1
01-304-0850	Drive Link	2	23	1	01-316-0020	Filter Assembly	22	17	1
01-304-0860	Rotor Set	2	24	1	01-317-0240	Filter Element	22	*	1
01-304-0870	Bolt Set	2	25	1	01-318-0090	Separator	25	43	1
01-304-0880	Shaft Key	2	27	1	01-401-0010	Housing Gasket	25	31	1
01-304-1550	Manifold Boot	2	14	1	01-402-0230	O-Ring	22	41	1
01-304-1560	Manifold (CCW)	2	13	1	01-402-0230	O-Ring	4	33	1
01-304-1570	Balance Plate Kit	2	*	1	01-402-0230	O-Ring	5	33	1
01-304-1580	Endcover	2	17	1	01-405-0370	Seal	16	14	1
01-305-0020	Sundstrand Pump	22	2	1	01-405-0400	Shaft Seal - Drive	25	2	1
01-305-0020	Sundstrand Pump	4	34	1	01-405-0460	Seal	17	31	2
01-305-0020	Sundstrand Pump	5	17	1	01-451-0010	Pipe Plug	1	13	1
01-305-0080	Seal Kit	22	*	1	01-451-0020	Pipe Plug	4	6	1
01-305-0080	Seal Kit	4	*	1	01-451-0020	Pipe Plug	5	8	1
01-305-0080	Seal Kit	5	*	1	01-453-0130	Pipe Coupling	5	7	1
01-305-0090	Cessna Pump	22	1	1	01-455-0020	Fitting	22	18	1
01-305-0090	Cessna Pump	4	27	1	01-455-0030	Pipe Elbow	4	3	2
01-305-0090	Cessna Pump	5	27	1	01-455-0080	Fitting	22	24	1
01-305-0120	Drive Shaft	25	8	1	01-455-0100	Elbow	1	12	1
01-305-0600	Seal Kit	22	*	1	01-456-0050	Pipe Nipple	4	2	1
01-305-0600	Seal Kit	4	*	1	01-456-0050	Pipe Nipple	5	6	1
01-305-0600	Seal Kit	5	*	1	01-456-0070	Pipe Nipple	4	4	1
01-305-1500	Relief Valve Ass'y	25	*	2	01-506-0030	Decal - Danger	23	11	1
01-305-1520	Spring	25	37	2	01-506-0040	Decal - Danger	23	12	1
01-305-1530	Relief Valve	25	38	2	01-506-0050	Decal - Danger	23	5	1
01-308-0050	Valve	1	31	2	01-506-0060	Decal - Danger	23	8	2
01-308-0050	Valve	22	30	2	01-506-0070	Decal - Danger	23	16	1
01-308-0130	Seal Kit	1	*	1	01-506-0080	Decal - Danger	23	6	2

\*Not illustrated

# PART NUMBER INDEX (Continued)

Part No.	Description	Pg. Ref. No.	Qty.	Part No.	Description	Pg. Ref. No.	Qty.
01-506-0090	Decal - Danger	23	2	1	3218-4	Jam Nut	15 7 2
01-506-0170	Decal - Hopper Door/ Hopper Lift	23	17	1	3218-5	Jam Nut	17 10 3
01-506-0570	Decal - Traction Pedal	23	4	1	3218-5	Jam Nut	22 8 4
01-506-0720	Decal - Turf Sweeper 4800HL	23	9	2	3218-6	Jam Nut	10 5 1
01-506-0980	Decal - Parking Brake	23	1	1	3218-6	Jam Nut	11 6 1
01-600-0050	Battery Cable	4	*	1	3218-7	Jam Nut	18 17 10
01-600-0050	Battery Cable	5	*	1	3219-3	Hex Nut	7 9 1
01-600-0060	Battery Cable	4	*	1	3219-9	Hex Nut	18 20 9
01-600-0190	Battery Cable	5	*	1	322-12	Capscrew - Hex Hd.	1 27 4
01-650-0140	All Thread	14	*	2	322-3	Capscrew - Hex Hd.	19 2 8
01-650-0160	All Thread	14	2	2	322-5	Capscrew - Hex Hd.	17 16 1
01-650-0280	All Thread	15	4	1	322-5	Capscrew - Hex Hd.	21 4 6
01-650-0420	All Thread	15	2	2	322-6	Capscrew - Hex Hd.	17 13 2
02-250-0020	Rod End Bearing	9	6	1	322-6	Capscrew - Hex Hd.	4 37 1
2412-133	R-Clamp	19	23	2	322-6	Capscrew - Hex Hd.	5 20 4
254-78	Bearing	17	30	2	322-7	Capscrew - Hex Hd.	4 20 3
321-4	Capscrew - Hex Hd.	19	25	2	3220-3	Jam Nut	9 7 3
321-6	Capscrew - Hex Hd.	4	14	5	3220-3	Jam Nut	7 8 2
321-6	Capscrew - Hex Hd.	5	14	2	3220-7	Jam Nut	16 7 1
32103-3	Wing Nut	18	29	1	323-10	Capscrew - Hex Hd.	1 3 4
32121-12	Roll Pin	7	14	1	323-10	Capscrew - Hex Hd.	4 28 2
3217-11	Hex Nut	10	15	3	323-10	Capscrew - Hex Hd.	5 28 2
3217-11	Hex Nut	13	9	1	323-11	Capscrew - Hex Hd.	10 17 1
3217-12	Hex Nut	18	24	2	323-11	Capscrew - Hex Hd.	16 28 3
3217-24	Hex Nut	11	14	3	323-6	Capscrew - Hex Hd.	1 19 3
3217-26	Hex Nut	4	32	2	323-6	Capscrew - Hex Hd.	10 8 2
3217-5	Hex Nut	19	13	2	323-6	Capscrew - Hex Hd.	11 8 2
3217-5	Hex Nut	4	17	5	323-6	Capscrew - Hex Hd.	17 19 2
3217-6	Hex Nut	17	15	4	323-6	Capscrew - Hex Hd.	4 30 2
3217-6	Hex Nut	1	30	4	323-6	Capscrew - Hex Hd.	5 30 2
3217-6	Hex Nut	19	5	8	323-7	Capscrew - Hex Hd.	19 22 8
3217-6	Hex Nut	21	6	6	323-7	Capscrew - Hex Hd.	4 31 3
3217-6	Hex Nut	4	5	4	323-7	Capscrew - Hex Hd.	5 31 2
3217-7	Hex Nut	1	11	13	323-7	Capscrew - Hex Hd.	6 8 2
3217-7	Hex Nut	9	9	5	323-8	Capscrew - Hex Hd.	12 10 2
3217-7	Hex Nut	10	10	2	323-8	Capscrew - Hex Hd.	4 9 4
3217-7	Hex Nut	11	10	2	323-8	Capscrew - Hex Hd.	5 9 4
3217-7	Hex Nut	12	13	2	323-8	Capscrew - Hex Hd.	8 16 1
3217-7	Hex Nut	13	12	4	323-9	Capscrew - Hex Hd.	17 2 1
3217-7	Hex Nut	14	4	14	323-9	Capscrew - Hex Hd.	18 6 8
3217-7	Hex Nut	16	26	7	3230-2	Carriage Bolt	17 43 1
3217-7	Hex Nut	17	6	3	3231-10	Carriage Bolt	18 11 1
3217-7	Hex Nut	19	7	19	3231-2	Carriage Bolt	19 20 6
3217-7	Hex Nut	4	12	2	325-12	Capscrew - Hex Hd.	1 15 8
3217-7	Hex Nut	5	12	6	325-5	Capscrew - Hex Hd.	9 5 1
3217-7	Hex Nut	6	11	6	325-5	Capscrew - Hex Hd.	16 9 3
3217-7	Hex Nut	7	6	4	325-6	Capscrew - Hex Hd.	17 23 2
3217-7	Hex Nut	8	19	1	325-6	Capscrew - Hex Hd.	18 2 6
3217-8	Hex Nut	15	5	11	325-6	Capscrew - Hex Hd.	12 5 2
3217-8	Hex Nut	17	28	4	325-7	Capscrew - Hex Hd.	20 3 2
3217-9	Hex Nut	1	17	8	325-7	Capscrew - Hex Hd.	8 6 2
3217-9	Hex Nut	12	8	2	325-7	Capscrew - Hex Hd.	20 9 4
3217-9	Hex Nut	13	17	3	325-8	Capscrew - Hex Hd.	20 9 4
3217-9	Hex Nut	16	12	3	3253-3	Lock Washer	19 12 2
3217-9	Hex Nut	17	9	4	3253-3	Lock Washer	4 16 5
3217-9	Hex Nut	18	5	6	3253-3	Lock Washer	5 16 2
3217-9	Hex Nut	22	5	6	3253-4	Lock Washer	17 14 2
3217-9	Hex Nut	8	9	2	3253-4	Lock Washer	1 29 4
3218-3	Jam Nut	10	20	2	3253-4	Lock Washer	19 4 8
3218-3	Jam Nut	17	7	1	3253-4	Lock Washer	21 5 6
					3253-4	Lock Washer	4 19 4
					3253-4	Lock Washer	5 19 4

\* Not Illustrated

# PART NUMBER INDEX (Continued)

Part No.	Description	Pg. No.	Ref. No.	Qty.	Part No.	Description	Pg. No.	Ref. No.	Qty.
3253-5	Lock Washer	1	8	5	3256-5	Flat Washer	15	6	8
3253-5	Lock Washer	10	9	2	3256-6	Flat Washer	10	12	6
3253-5	Lock Washer	11	9	2	3256-6	Flat Washer	11	12	5
3253-5	Lock Washer	12	12	2	3256-6	Flat Washer	13	18	2
3253-5	Lock Washer	16	19	3	3256-6	Flat Washer	16	10	3
3253-5	Lock Washer	17	20	2	3256-6	Flat Washer	17	11	6
3253-5	Lock Washer	18	13	7	3256-6	Flat Washer	20	4	20
3253-5	Lock Washer	19	6	19	3256-7	Flat Washer	13	6	3
3253-5	Lock Washer	4	11	8	327-14	Capscrew - Hex Hd.	13	4	1
3253-5	Lock Washer	5	11	10	327-6	Capscrew - Hex Hd.	10	6	1
3253-5	Lock Washer	6	10	2	327-6	Capscrew - Hex Hd.	11	2	1
3253-5	Lock Washer	8	18	1	3272-11	Cotter Pin	7	16	2
3253-6	Lock Washer	15	8	1	3272-15	Cotter Pin	16	23	1
3253-6	Lock Washer	17	27	4	3272-21	Cotter Pin	13	3	1
3253-7	Lock Washer	1	16	8	3272-23	Cotter Pin	9	17	1
3253-7	Lock Washer	9	4	1	3272-23	Cotter Pin	17	34	1
3253-7	Lock Washer	12	7	2	3272-23	Cotter Pin	8	14	3
3253-7	Lock Washer	16	11	3	328-23	Capscrew - Hex Hd.	18	14	2
3253-7	Lock Washer	17	41	2	3296-39	Lock Nut	1	5	2
3253-7	Lock Washer	18	4	6	3296-39	Lock Nut	13	11	1
3253-7	Lock Washer	20	7	6	3296-39	Lock Nut	18	27	2
3253-7	Lock Washer	8	8	2	3296-39	Lock Nut	4	35	2
3253-8	Lock Washer	10	4	1	3296-39	Lock Nut	5	34	2
3253-8	Lock Washer	11	5	1	3296-48	Lock Nut	9	20	3
3253-8	Lock Washer	13	8	1	48-002-0071	Throttle Assembly	4	7	1
3256-2	Flat Washer	19	26	2	48-002-0101	Breather Cap	22	19	1
3256-2	Flat Washer	4	17	5	48-002-5441	Idler Sprocket Assembly	9	*	1
3256-2	Flat Washer	5	15	2	48-002-5441	Idler Sprocket Assembly	8	*	1
3256-2	Flat Washer	7	15	2	48-004-1211	Belt Slip Pin	14	6	2
3256-24	"SAE" Flat Washer	9	21	1	48-004-1282	Steering Yoke Gear	16	27	1
3256-24	"SAE" Flat Washer	10	19	1	48-004-1711	Idler Spring Rod	13	13	1
3256-24	"SAE" Flat Washer	14	8	4	48-004-1751	Air Deflector	1	18	1
3256-24	"SAE" Flat Washer	4	36	4	48-004-1861	Hose Hold Down Bracket	1	10	2
3256-24	"SAE" Flat Washer	5	35	4	48-004-1861	Hose Hold Down Bracket	15	3	2
3256-24	"SAE" Flat Washer	8	17	1	48-004-1931	Key	8	12	2
3256-26	"SAE" Flat Washer	9	3	1	48-004-1961	Key	16	6	1
3256-26	"SAE" Flat Washer	12	6	2	48-004-2101	Spacer	14	*	2
3256-26	"SAE" Flat Washer	18	3	12	48-004-2601	Spring Rod	7	11	1
3256-26	"SAE" Flat Washer	8	7	2	48-004-3001	Door Linkage-Upper	20	2	2
3256-27	"SAE" Flat Washer	10	3	1	48-004-3052	Upper Arm	18	18	2
3256-27	"SAE" Flat Washer	11	4	1	48-004-3131	Pump Support	4	29	1
3256-28	"SAE" Flat Washer	16	21	1	48-004-3131	Pump Support	5	29	1
3256-3	Flat Washer	1	28	4	48-004-3291	Belt Slip Bracket	14	1	1
3256-3	Flat Washer	19	3	8	48-004-3441	Spacer	18	15	2
3256-3	Flat Washer	21	7	4	48-004-3471	Spacer	13	5	1
3256-3	Flat Washer	4	13	8	48-004-3831	Battery Hold Down	6	12	1
3256-3	Flat Washer	7	17	2	48-004-3881	Spacer	9	2	1
3256-4	Flat Washer	1	9	5	48-004-3891	Idler Spring Rod	9	10	1
3256-4	Flat Washer	9	11	2	48-004-4041	Reel Chain	8	27	1
3256-4	Flat Washer	12	11	2	48-004-4071	Throttle Outer Sheath	4	*	1
3256-4	Flat Washer	13	14	3	48-004-4081	Throttle Inner Wire	4	*	1
3256-4	Flat Washer	14	5	12	48-004-4111	Fuel Line	6	*	1
3256-4	Flat Washer	17	3	2	48-004-4461	Hopper Pivot Adj. Bracket-RH	19	14	1
3256-4	Flat Washer	18	12	1	48-004-4641	Peep Hole Cover	19	17	1
3256-4	Flat Washer	19	11	16	48-004-4651	Sector Spacer	16	16	3
3256-4	Flat Washer	4	10	10	48-004-4831	Hose Bracket	18	22	2
3256-4	Flat Washer	5	10	20	48-004-4921	Hose Assembly	22	10	1
3256-4	Flat Washer	6	9	12	48-004-4931	Hose Assembly	22	23	1
3256-4	Flat Washer	7	3	9	48-004-5052	Engine Adaptor	4	18	1
3256-42	Flat Washer	20	13	2	48-004-5062	Engine Adaptor	5	18	1
3256-5	Flat Washer	9	19	3	48-004-5071	Key	4	25	1

\* Not Illustrated

# PART NUMBER INDEX (Continued)

Part No.	Description	Pg. No.	Ref. No.	Qty.	Part No.	Description	Pg. No.	Ref. No.	Qty.
48-004-5071	Key	5	25	1	48-005-0602	High Lift Hopper Door	20	1	1
48-004-5131	PVK80 Rubber	6	7	2	48-005-0611	Idler Arm	13	1	1
48-004-5451	Hopper Floor Seal	19	19	1	48-005-0621	Foot Pedal	7	1	1
48-004-5521	Cessna Pump Spacer	4	26	1	48-005-0641	Tow Valve Handle	22	12	1
48-004-5521	Cessna Pump Spacer	5	26	1	48-005-0641	Tow Valve Handle	4	*	1
48-004-5651	Muffler Guard	5	3	1	48-005-0641	Tow Valve Handle	5	*	1
48-004-5841	Reel Plate Spacer	10	2	1	48-005-0671	Brake Pedal	17	1	1
48-004-5841	Reel Plate Spacer	11	3	1	48-005-0712	Gas Tank	6	1	1
48-004-6101	Hopper Box Spacer	20	6	4	48-005-0774	Main Frame	1	1	1
48-004-6161	Rubber Flap Mount	19	18	1	48-005-0781	Brake Stop Weldment	17	5	1
48-004-6191	Hopper Flap	19	21	1	48-005-0791	Air Cleaner Mount	21	3	1
48-004-6241	Brake Stop Plate	17	18	1	48-005-5781	Reel Lift Rod Assembly-R.H.	11	11	1
48-004-6261	Fuel Line	6	6	1	48-005-8231	Control Rod	7	5	1
48-004-6271	Spacer	14	3	2	52-9640	Decal - Hydraulic Oil	23	13	1
48-004-6282	Wet Leaf Deflector	19	9	1	54-002-0011	Steering Column Assembly	16	*	1
48-004-6302	Air Cleaner Base	21	2	1	54-004-1241	Brake Shoe Bracket	17	26	1
48-004-6311	Hopper Box Spacer	20	17	2	54-004-1501	Steering Shaft	16	3	1
48-004-6391	Flywheel Guard	5	13	1	54-004-1701	Hose	21	13	1
48-004-6441	Flywheel Guard	4	8	1	54-005-0242	Steering Yoke Assembly	16	13	1
48-004-6591	Hopper Pivot Adj. Bracket-LH	19	*	1	54-005-0251	Axle	17	22	1
48-004-6631	Break Pedal Stop	17	42	1	54-005-0261	Brake Mount	17	21	1
48-005-0121	Spring Tension Adjustment	13	10	1	54-005-0282	Front Wheel	17	24	1
48-005-0131	Front Reel Assembly	12	2	1	54-005-1521	Steering Column Assembly	16	2	1
48-005-0131	Front Reel Assembly	8	2	1	58-6520	Decal - Grease	23	3	10
48-005-0162	Idler Cover	9	18	1	66-004-3211	Key	12	16	1
48-005-0172	Reel Plate Assembly-R.H.	11	1	1	66-6140	Decal - Toro	23	10	1
48-005-0172	Reel Plate Assembly-R.H.	12	3	1	67-7920	Decal - Toro	23	7	1
48-005-0182	Reel Plate Assembly-L.H.	10	1	1	71-3730	Decal - Gas Only	23	14	1
48-005-0182	Reel Plate Assembly, L.H.	8	4	1	74-0720	Manual Tube	19	24	1
48-005-0191	Idler Shaft Assembly	9	1	1	75-5190	Decal - No Riders	23	15	1
48-005-0201	Rear Reel Assembly	12	1	1	82-004-1171	Key	12	19	1
48-005-0201	Rear Reel Assembly	8	1	1	92-4622	Back Plate Assembly	25	33	1
48-005-0222	Handle	10	16	1	92-4623	Housing Assembly	25	9	1
48-005-0231	Reel Lift Rod Assembly-L.H.	10	14	1	92-4624	Rotating Kit Assembly	25	29	1
48-005-0241	Pump Control Arm Assembly	7	10	1	92-4625	Camplate	25	19	1
48-005-0292	Dust Shield Assembly	19	8	1	92-4626	Washer	25	3	1
48-005-0322	Belt Guard	14	7	1	92-4629	Bearing Race	25	5	2
48-005-0322	Belt Guard	15	1	1	92-4631	Washer	25	13	2
48-005-0331	Hopper Door Cyl. Pin-upper	20	11	1	92-4633	Screw - Pan Head	25	17	4
48-005-0341	Hopper Door Cyl. Pin-lower	20	10	1	92-4634	Plug Assembly	25	35	2
48-005-0352	Main Lift Arm	18	1	1	92-4636	Seal Cover	25	15	1
48-005-0371	Lower Pivot Assembly	18	21	2	92-4637	Trunnion Cover	25	18	1
48-005-0381	Upper Pivot Arm Bracket	18	19	2	92-4638	Cover - O-Ring	25	16	1
48-005-0432	Reel Lift Assembly	10	7	1	92-4639	Capscrew	25	54	2
48-005-0432	Reel Lift Assembly	11	7	1	92-4640	Capscrew	25	34	2
48-005-0462	Seat Mount	1	2	1	92-4641	Key - Drive Shaft	25	7	1
48-005-0513	Hopper	19	1	1	92-4643	Plug Assembly	25	61	1
48-005-0561	Cylinder Safety Stop	18	10	1	92-4646	Charge Pump Adaptor	25	52	1
48-005-0571	Cylinder Adj. Pivot	18	25	1	92-4649	Roll Pin	25	55	1
48-005-0591	Reel Lift Tube Assembly	10	11	1	92-4650	Seal Kit	25	*	1
48-005-0591	Reel Lift Tube Assembly	11	15	3	93-004-0511	Spacer	21	12	1

\*Not Illustrated

## PRODUCT CHANGES

In an effort to make improvements available to TORO owners as quickly as possible minor changes are incorporated into Toro's products from time to time that do not become immediately shown in the Parts Catalog. If such a change has been made in your unit which is not reflected in your manual see your TORO Distributor or an Authorized Service Dealer for information and part numbers.

## IDENTIFICATION & ORDERING

### MODEL AND NUMBERS

The TURF SWEEPER 4800HL has two identification numbers; a model number and a serial number. The two numbers are stamped on a plate which is located on the seat bracket. In any correspondence concerning the Turf Sweeper 4800HL, supply model and serial numbers to assure that correct information and replacement parts are obtained.

To order replacement parts from your TORO Distributor or an Authorized Service Dealer, supply the following information:

1. Model and serial number of the unit.
2. Part number description and the quantity of part (s) desired.

**NOTE:** Do not order by reference number if a parts catalog is being used: use the PART NUMBER.

## TABLE OF CONTENTS

Description	Page	Description	Page
Main Frame Assembly . . . . .	1	Belt Slip Bracket . . . . .	14
Hydraulic Motor - No. 01-304-0410 . . . . .	2	Belt Guard & Hose Brackets . . . . .	15
Hydraulic Valve - No. 01-308-0050 . . . . .	3	Steering Assembly . . . . .	16
Briggs & Stratton Engine Mounting - Model #44050 . . . . .	4	Brake System . . . . .	17
Onan Engine Mounting - Model #44055 . . . . .	5	Hopper Lift Arm Assembly . . . . .	18
Gas Tank & Battery Hold Down . . . . .	6	Hopper Assembly . . . . .	19
Foot Pedal & Pump Control Rod Assembly . . . . .	7	Hopper Door Assembly . . . . .	20
Sweeper Reels & Timing Chain Assembly . . . . .	8	Donaldson Air Cleaner - Model No. 44062 . . . . .	21
Chain Idler & Guard Assembly . . . . .	9	Hydraulic Schematic - 4800HL . . . . .	22
Reel Lift Assembly-L.H. . . . .	10	Decals . . . . .	23
Reel Lift Assembly-R.H. . . . .	11	Cessna Pump - No. 01-305-0090 . . . . .	24 - 25
Belt Drive Assembly . . . . .	12	Part Number Index . . . . .	26 - 30
Belt Idler Assembly . . . . .	13		

# NOTES

**NOTES**

# NOTES

# NOTES

