



Count on it.

Operator's Manual

Flex-Force Power System™ 60V MAX Snowthrower

Model No. 39901—Serial No. 319000001 and Up

Model No. 39901T—Serial No. 319000001 and Up

Model No. 39902—Serial No. 319000001 and Up

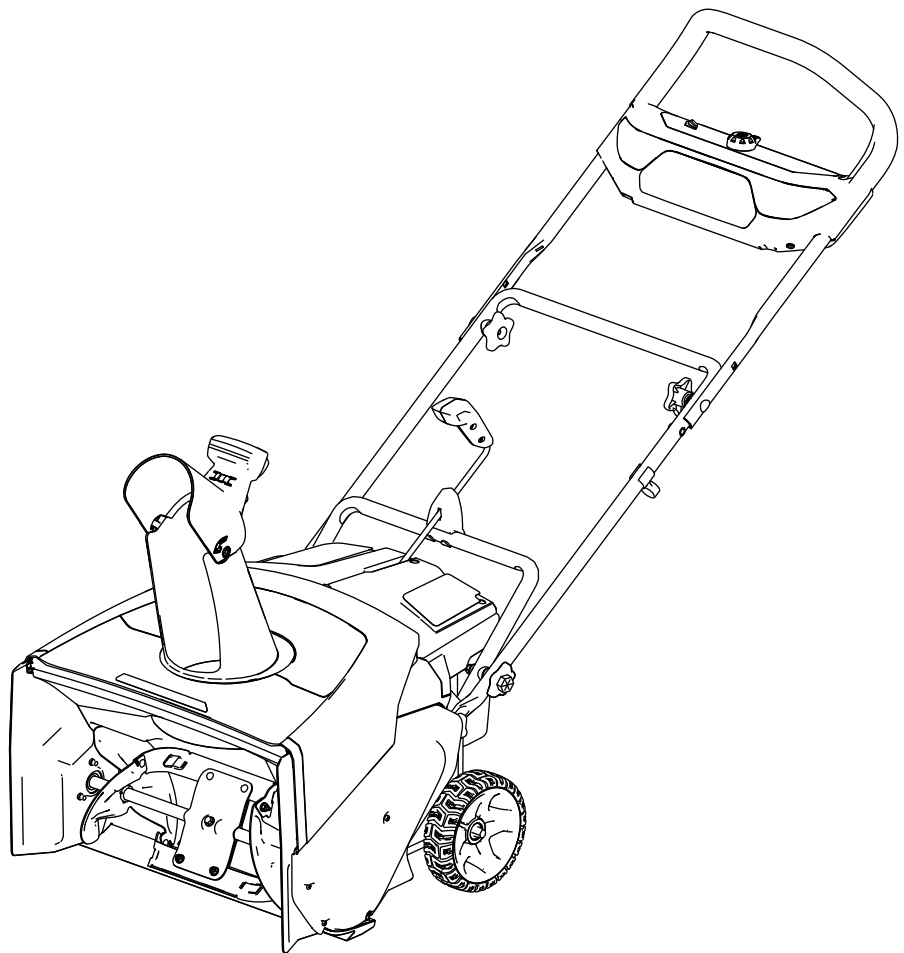



For assistance, please see www.Toro.com/support for instructional videos or contact 1-888-384-9939 before returning this product.

⚠ WARNING

CALIFORNIA Proposition 65 Warning

The power cord on this product contains lead, a chemical known to the State of California to cause birth defects or other reproductive harm. Wash hands after handling.

Use of this product may cause exposure to chemicals known to the State of California to cause cancer, birth defects, or other reproductive harm.

Whenever you need service, genuine the manufacturer parts, or additional information, contact an Authorized Service Dealer or the manufacturer Customer Service and have the model and serial numbers of your product ready. Figure 1 identifies the location of the model and serial numbers on the product. Write the numbers in the space provided.

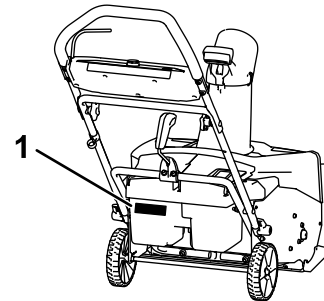

Figure 1

g288478

1. Model and serial number location

Model No. _____

Serial No. _____

This manual identifies potential hazards and has safety messages identified by the safety-alert symbol (Figure 2), which signals a hazard that may cause serious injury or death if you do not follow the recommended precautions.



Figure 2

Safety-alert symbol

g000502

This manual uses 2 words to highlight information. **Important** calls attention to special mechanical information and **Note** emphasizes general information worthy of special attention.

Introduction

This machine is intended to be used by residential homeowners. It is designed for removing up to 30 cm (12 inches) of snow from patios, sidewalks, and small driveways. It is not designed for removing materials other than snow, nor is it designed for clearing off gravel surfaces. It is designed to use Toro Flex-Force lithium-ion battery pack Model 88675 (provided with Model 39901) or 88660 (provided with Model 39902); it can also use battery pack Model 88620, Model 88625, Model 88640, or Model 88650. These battery packs are designed to be charged only by battery charger Models 88602 (provided with Models 39901 and 39902), 88605, or 88610. Using this product for purposes other than its intended use could prove dangerous to you and bystanders.

Model 39901T does not include a battery or a charger.

Read this information carefully to learn how to operate and maintain your product properly and to avoid injury and product damage. You are responsible for operating the product properly and safely.

Visit www.Toro.com for more information, including safety tips, training materials, accessory information, help finding a dealer, or to register your product.

Safety

READ ALL INSTRUCTIONS

WARNING—When using an electrical machine, basic safety precautions should always be followed to reduce the risk of fire, electric shock, or injury, including the following:

I. Training

1. The operator of the machine is responsible for any accidents or hazards occurring to others or their property.
2. Read and understand the contents of this *Operator's Manual* before you start the machine. Ensure that everyone using this machine knows how to use it, knows how to shut it off quickly, and understands the warnings.
3. Do not allow children to use or play with the machine, battery pack, or the battery charger; local regulations may restrict the age of the operator.
4. Do not allow children or untrained people to operate or service this device. Allow only people who are responsible, trained, familiar with the instructions, and physically capable to operate or service the device.
5. Before using the machine, battery pack, and battery charger, read all the instructions and cautionary markings on these products.
6. Become familiar with the controls and proper use of the machine, battery pack, and battery charger.

II. Preparation

1. Keep bystanders and children out of the operating area.
2. Never allow children to operate the machine.
3. Do not operate the machine without all guards and safety devices in place and functioning properly on the machine.
4. Inspect the area where you will use the machine and remove all objects that could interfere with the operation of the machine or that the machine could throw.
5. Use only the battery pack specified by Toro. Using other accessories and attachments may increase the risk of injury and fire.
6. Plugging the battery charger into an outlet that is not 120 V can cause a fire or electric shock. Do not plug the battery charger into an outlet other than 120 V.
7. Do not use a damaged or modified battery pack or battery charger, which may exhibit

unpredictable behavior that results in fire, explosion, or risk of injury.

8. If the supply cord to the battery charger is damaged, contact an Authorized Service Dealer to replace it.
9. Do not use non-rechargeable batteries.
10. Charge the battery pack with only the battery charger specified by Toro. A charger suitable for 1 type of battery pack may create a risk of fire when used with another battery pack.
11. Charge the battery pack in a well-ventilated area only.
12. Do not expose a battery pack or battery charger to fire or to temperatures higher than 68°C (154°F).
13. Follow all charging instructions and do not charge the battery pack outside of the temperature range specified in the instructions. Otherwise, you may damage the battery pack and increase the risk of fire.
14. Dress properly—Wear appropriate clothing, including eye protection; long pants; and rubber boots. Tie back long hair and do not wear loose clothing or loose jewelry that can get caught in moving parts.

III. Operation

1. Contact with the moving rotor will cause serious injury. Keep your hands and feet away from all moving parts of the machine. Keep clear of any discharge opening.
2. Using this machine for purposes other than its intended use could prove dangerous to you and bystanders.
3. Prevent unintentional starting—Ensure that the electric-start button is removed from the ignition before connecting the battery pack and handling the machine.
4. Use your full attention while operating the machine. Do not engage in any activity that causes distractions; otherwise, injury or property damage may occur.
5. Stop the machine, remove the electric-start button, remove the battery pack from the machine, and wait for all movement to stop before adjusting, servicing, cleaning, or storing the machine.
6. Do not use the machine on a gravel surface.
7. Remove the battery pack and electric-start button from the machine whenever you leave it unattended or before changing accessories.
8. Do not force the machine—Allow the machine to do the job better and safer at the rate for which it was designed.

9. Stay alert—Watch what you are doing and use common sense when operating the machine. Do not use the machine while ill, tired, or under the influence of alcohol or drugs.
10. Operate the machine only in good visibility and appropriate weather conditions.
11. Use extreme caution when reversing or pulling the machine toward you.
12. Keep proper footing and balance at all times, especially on slopes. Use extreme caution when changing directions on slopes. Do not operate the machine on exceedingly steep slopes. Walk, never run with the machine.
13. Do not direct the discharge material toward anyone. Avoid discharging material against a wall or obstruction; material may ricochet toward you. Stop the machine when crossing gravel surfaces.
14. If the machine strikes an object or starts to vibrate, immediately shut off the machine, remove the electric-start button, remove the battery pack, and wait for all movement to stop before examining the machine for damage. Make all necessary repairs before resuming operation.
15. Shut off the machine whenever you leave the operating position for any reason.
16. Shut off the machine before unclogging the machine and always use a stick or a cleanout tool to remove the clog.
17. Stop the machine and remove the electric-start button before loading the machine for hauling.
18. Under abusive conditions, the battery pack may eject liquid; avoid contact. If you accidentally come into contact with the liquid, flush with water. If the liquid contacts your eyes, seek medical help. Liquid ejected from the battery pack may cause irritation or burns.
5. For best performance, use only genuine Toro replacement parts and accessories. Other replacement parts and accessories could be dangerous, and such use could void the product warranty.
6. Maintain the machine—Keep handles dry, clean, and free from oil and grease. Keep guards in place and in working order. Use identical replacement parts only.
7. Check all hardware at frequent intervals for proper tightness to ensure that the machine is in safe working condition.
8. Check the machine for damaged parts. Check for misaligned and binding moving parts, broken parts, mounting, and any other condition that may affect its operation. Unless indicated in the instructions, have an Authorized Service Dealer repair or replace a damaged guard or part.
9. When the battery pack is not in use, keep it away from metal objects such as paper clips, coins, keys, nails, and screws that can make a connection from 1 terminal to another. Shorting the battery terminals may cause burns or a fire.
10. When you are not using the machine, store it indoors in a dry, secure place out of the reach of children.
11. CAUTION—A mistreated battery pack may present a risk of fire or chemical burn. Do not disassemble the battery pack. Do not heat the battery pack above 68°C (154°F) or incinerate it. Replace the battery pack with a genuine Toro battery pack only; using another type of battery pack may cause a fire or explosion. Keep battery packs out of the reach of children and in the original packaging until you are ready to use them.
12. Do not dispose of the battery in a fire. The cell may explode. Check with local codes for possible special disposal instructions.

IV. Maintenance and Storage

1. Stop the machine, remove the electric-start button, remove the battery pack from the machine, and wait for all movement to stop before adjusting, servicing, cleaning, or storing the machine.
2. Do not attempt to repair the machine except as indicated in the instructions. Have an Authorized Service Dealer perform service on the machine using identical replacement parts.
3. Wear gloves and eye protection when servicing the machine.
4. When servicing the rotor, be aware that the rotor can still move even though the power source is off.

SAVE THESE INSTRUCTIONS

Safety and Instructional Decals



Safety decals and instructions are easily visible to the operator and are located near any area of potential danger. Replace any decal that is damaged or missing.

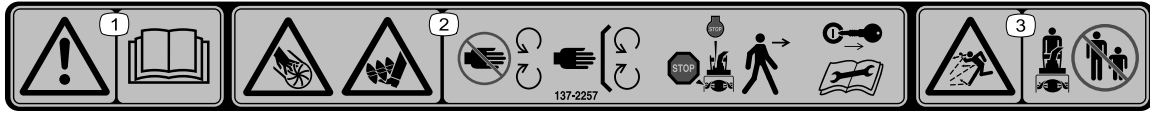

137-2257

decal137-2257

- Warning—read the *Operator's Manual*.
- Cutting/dismemberment of hand hazard, impeller; cutting/entanglement of foot hazard, auger—stay away from moving parts; keep all guards and shields in place; shut off the engine and remove the key before leaving the machine; read the *Operator's Manual* before performing maintenance.
- Thrown object hazard—keep bystanders away.

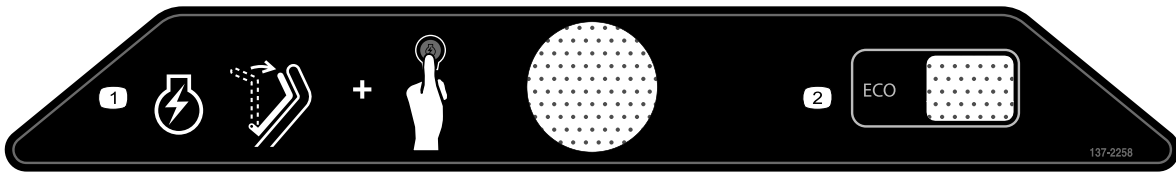

137-2258

decal137-2258

- To start the engine, bring the bail to the handle and press the ignition button.
- ECO



137-9462

decal137-9462



137-9463

decal137-9463

- The battery pack is charging.
- The battery pack is fully charged.
- The battery pack is over or under the appropriate temperature range.
- Battery pack charging fault



137-9456

decal137-9456

1. Read the *Operator's Manual*.
2. Keep away from open fire or flames.
3. Do not expose to rain.



138-6697

decal138-6697

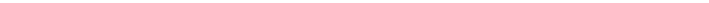

114-9034

decal114-9034



137-9455

decal137-9455

1. Read the *Operator's Manual*.
2. Keep away from open fire or flames.
3. Do not expose to rain.

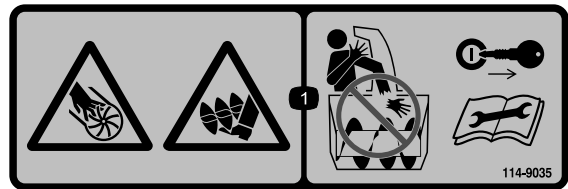

114-9035

decal114-9035

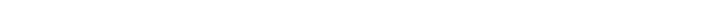

1. Cutting/dismemberment hazard of hand, impeller; cutting/dismemberment hazard of foot, auger—do not place your hand in the chute; remove the key and read the *Operator's Manual* before performing maintenance.

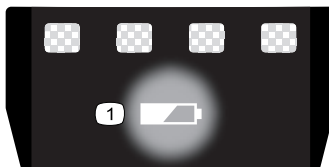

137-9461

decal137-9461

1. Battery charge status

Setup

Loose Parts

Use the chart below to verify that all parts have been shipped.

| Procedure | Description | Qty. | Use |
|-----------|-------------------|------|---------------------------------------|
| 1 | No parts required | – | Mount the battery charger (optional). |
| 2 | No parts required | – | Unfold the handle. |
| 3 | Chute deflector | 1 | Install the chute deflector. |
| 4 | Chute-control rod | 1 | Install the chute-control rod. |

Important: The battery pack is not fully charged when you purchase it. Before using the machine for the first time, refer to [Charging the Battery Pack \(page 14\)](#).



Mounting the Battery Charger (Optional)

No Parts Required

Procedure

If desired, mount the battery charger securely on a wall using the wall-mount key holes on the back of the charger.

Mount it indoors (such as a garage or other dry place), near a power outlet, and out of the reach of children.

Refer to [Figure 3](#) for assistance in mounting the charger.

Slide the charger over the appropriately positioned hardware to secure the charger in place (hardware not included).

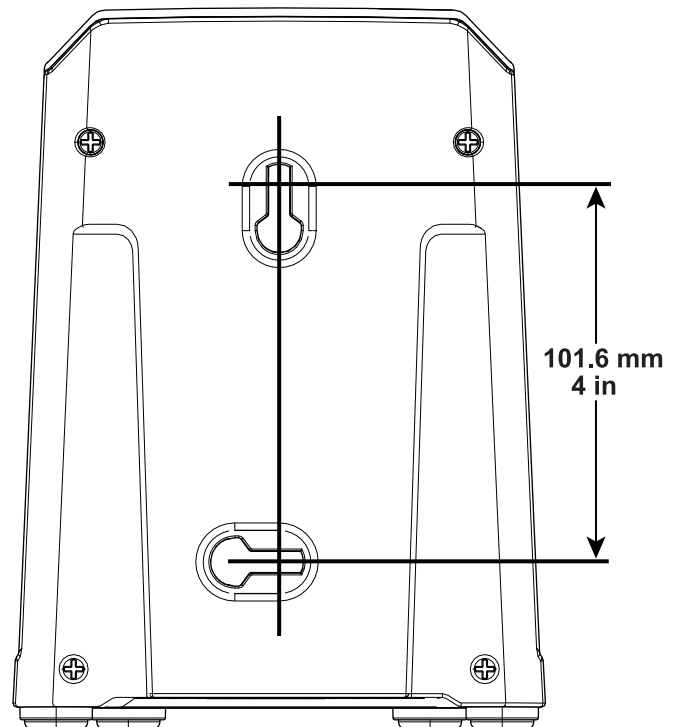

Figure 3

g247359

2

Unfolding the Handle

No Parts Required

Procedure

1. Remove the machine from the box.
2. Unfold the upper handle and allow the upper handle knobs to snap into place (A of Figure 4).
3. Tighten the handle knobs (B of Figure 4).

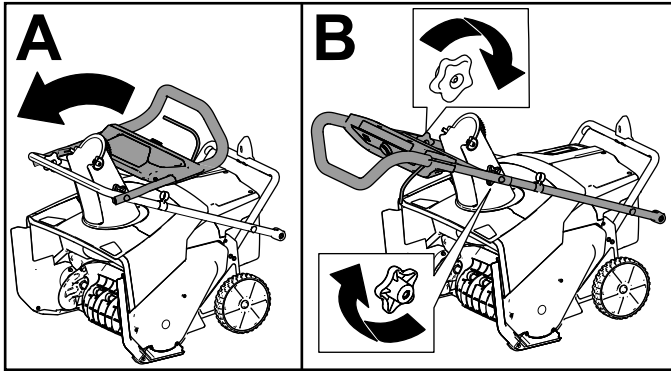

Figure 4

5. Move the lower handle into place and install the lower handle knobs as shown in Figure 6.

Note: You may use a wrench on the hex on the outside of the knob to tighten the knob.

Important: Tighten the knobs until the handlebar touches the side plate with no gap.

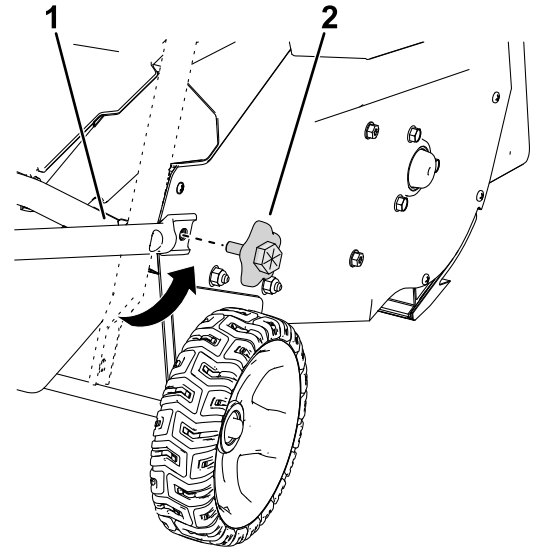

Figure 6

1. Align the lower handle with the weld nuts.
2. Install the lower handle knobs.

4. Remove the lower handle knobs from both sides of the machine (Figure 5).

Note: The lower knobs are installed to a weld nut in the side of the machine.

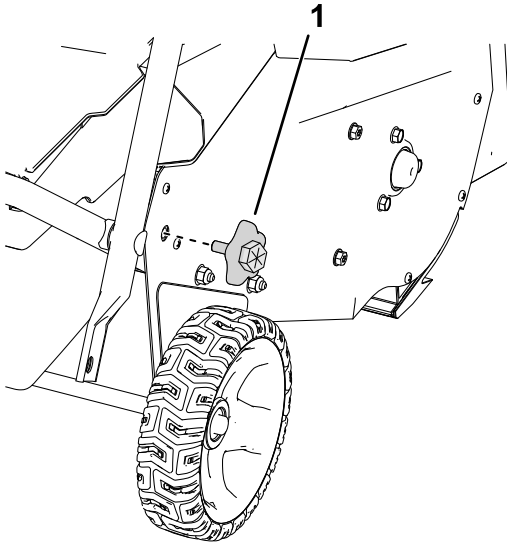

Figure 5
Right side shown

1. Lower handle knob

3

Installing the Chute Deflector

Parts needed for this procedure:

| | |
|---|-----------------|
| 1 | Chute deflector |
|---|-----------------|

Procedure

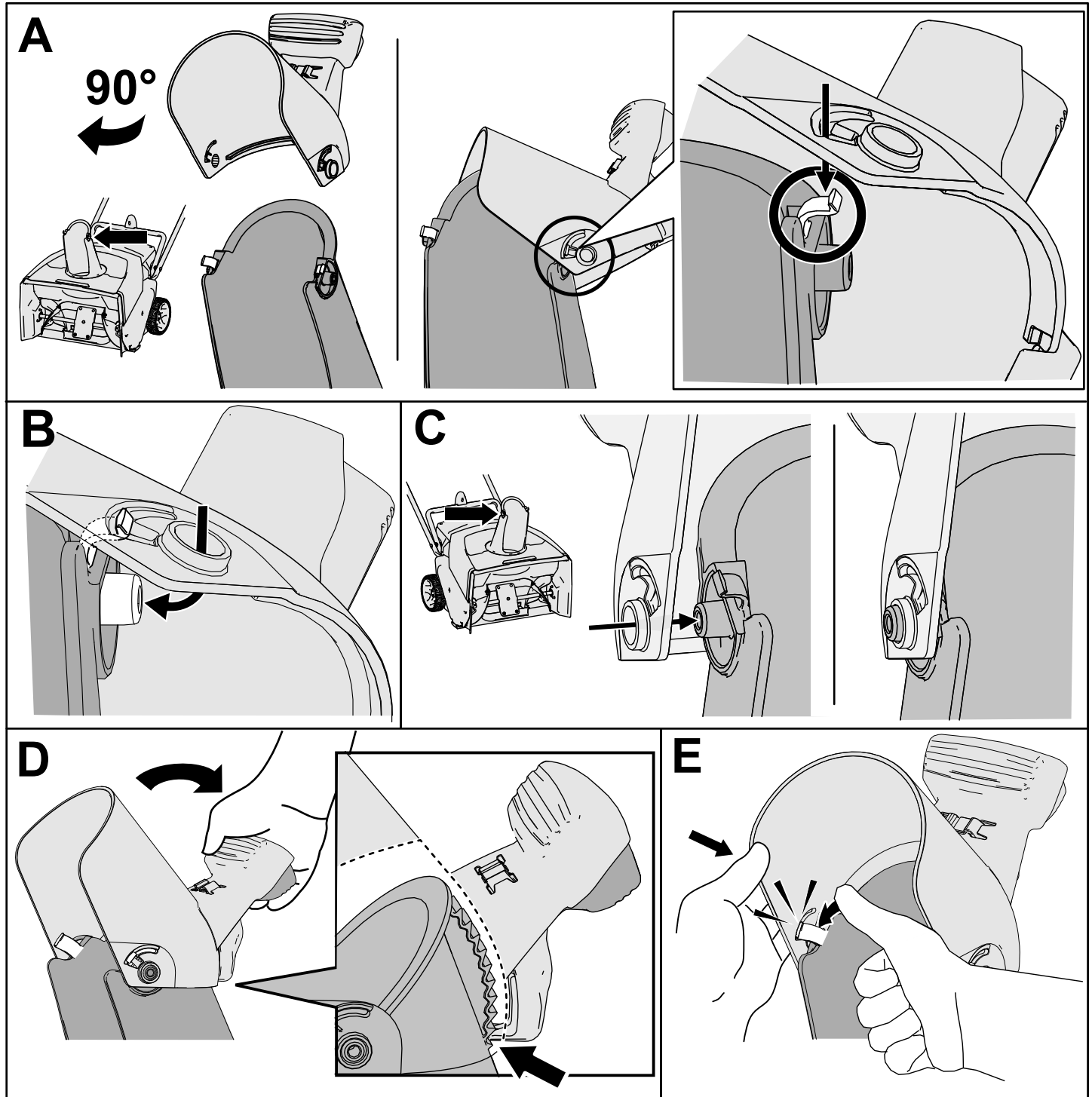

Figure 7

g316999

4

Installing the Chute-Control Rod

Parts needed for this procedure:

| | |
|---|-------------------|
| 1 | Chute-control rod |
|---|-------------------|

Procedure

1. Ensure that the chute is facing forward (Figure 8).
2. With the handle facing forward, install the chute-control rod into the guide and push it down until it snaps into place (Figure 8).

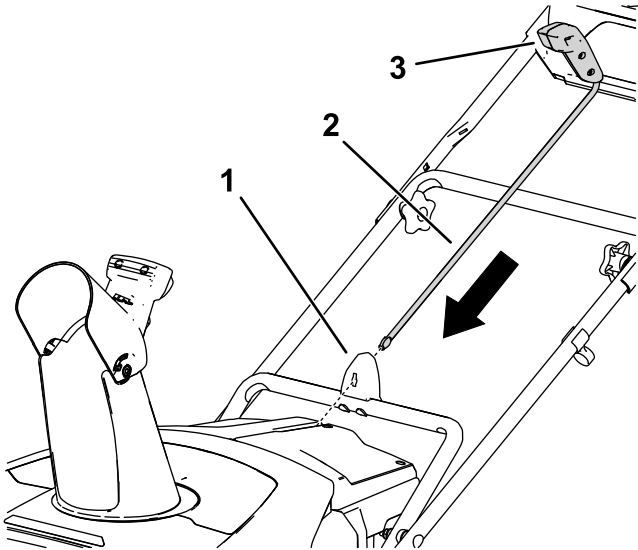

g282249

Figure 8

1. Chute-control guide
2. Chute-control rod
3. Chute-control handle

Product Overview

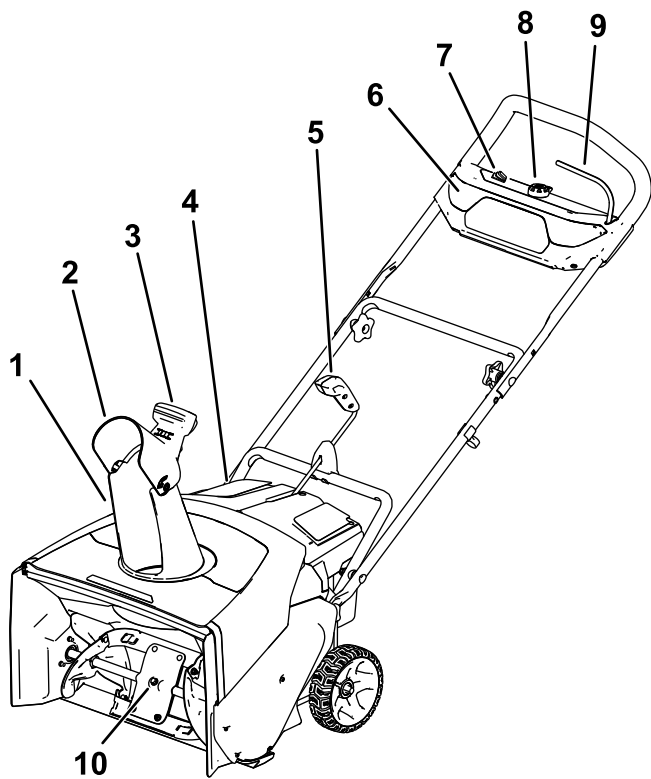

Figure 9

g318456

- | | |
|----------------------------|--------------------------|
| 1. Discharge chute | 6. Headlight |
| 2. Chute deflector | 7. ECO switch |
| 3. Chute-deflector handle | 8. Electric-start button |
| 4. Battery-compartment lid | 9. Bail |
| 5. Chute-control rod | 10. Rotor blades |

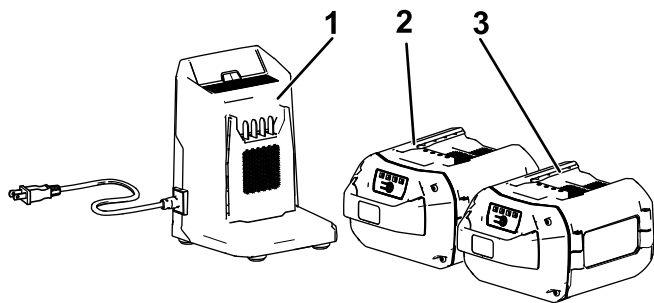

Figure 10

g359246

- | | |
|--|---|
| 1. Battery charger Model 88602 (included with Model 39901 and 39902) | 3. Battery pack Model 88660 (2 included with Model 39902) |
| 2. Battery pack Model 88675 (included with Model 39901) | |

Specifications

Battery Pack

| Model | 88660 | 88675 |
|---|--------|--------|
| Battery pack capacity | 6.0 Ah | 7.5 Ah |
| | 324 Wh | 405 Wh |
| Battery manufacturer rating = 60V maximum and 54V nominal. Actual voltage varies with load. | | |

Battery Charger

| | |
|--------|-------------------------------------|
| Model | 88602 |
| Type | 60V MAX Lithium-Ion Battery Charger |
| Input | 120V AC 50/60Hz Max 2.0A |
| Output | 60V MAX DC 2.0A |

Appropriate Temperature Ranges

| | |
|----------------------------------|--------------------------------|
| Charge/store the battery pack at | 5°C (41°F) to 40°C (104°F)* |
| Use the machine at | -30°C (-22°F) to 23°C (73°F)* |
| Store the machine at | -30°C (-22°F) to 49°C (120°F)* |

*Charging time will increase if you do not charge the battery within this range.

Store the machine, battery pack, and battery charger in an enclosed clean, dry area.

Attachments/Accessories

A selection of Toro approved attachments and accessories may be available for use with the machine to enhance and expand its capabilities. Contact your Authorized Service Dealer or authorized Toro distributor or go to www.Toro.com for a list of all approved attachments and accessories.

To ensure optimum performance and continued safety certification of the machine, use only genuine Toro replacement parts and accessories. Replacement parts and accessories made by other manufacturers could be dangerous, and such use could void the product warranty.

Operation

Installing the Battery Pack

Important: Use the battery pack only in temperatures that are within the appropriate range; refer to [Specifications \(page 11\)](#).

1. Make sure that the vents on the battery are clear of any dust and debris.
2. Lift up the battery-compartment lid (A of [Figure 11](#)).
3. Line up the cavity in the battery pack with the tongue on the machine and slide the battery pack into the compartment until it lock into place (B of [Figure 11](#)).
4. Close the battery-compartment lid (C of [Figure 11](#)).

Note: If the battery-compartment lid does not close completely, the battery is not fully installed.

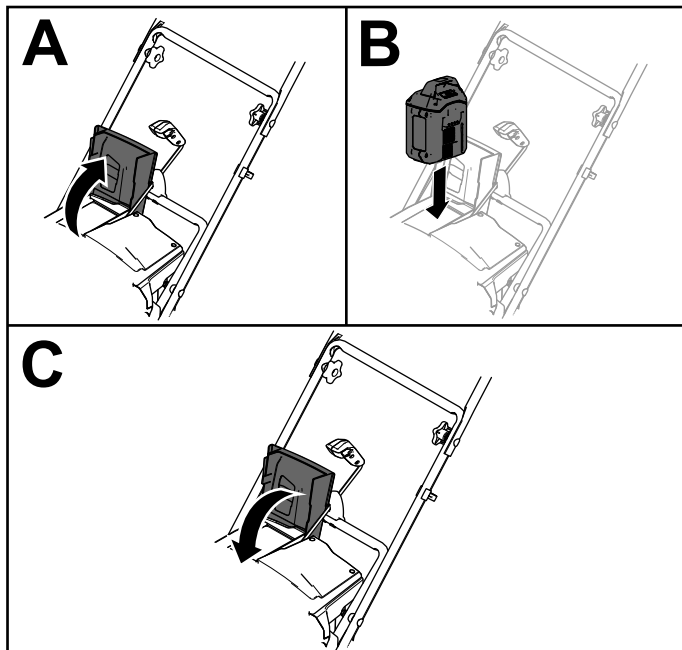

Figure 11

g282250

Starting the Machine

1. Ensure that the battery pack is installed in the machine; refer to [Installing the Battery Pack \(page 12\)](#).
2. Insert the electric-start button into the electric starter (A of [Figure 12](#)).
3. Squeeze the bail and hold it to the handle (B and C of [Figure 12](#)).

Note: When you squeeze the bail, the lights turn on and the battery-charge indicator lights on the battery illuminate.

4. Press the electric-start button until the motor starts (D of [Figure 12](#)).

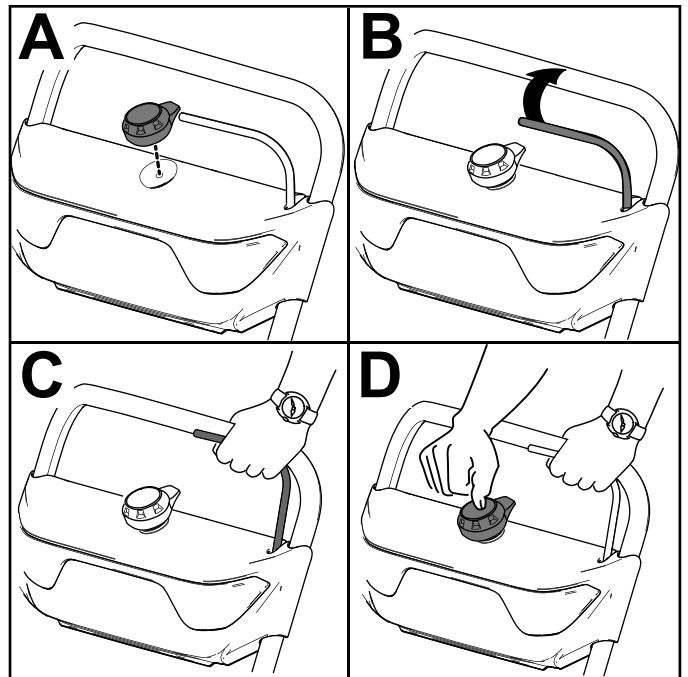

Figure 12

g288479

Activating ECO Mode

Using ECO mode may extend battery life by reducing rotor speed; use ECO mode whenever you are moving snow a short distance. Activate ECO mode using the ECO switch as shown in [Figure 9](#).

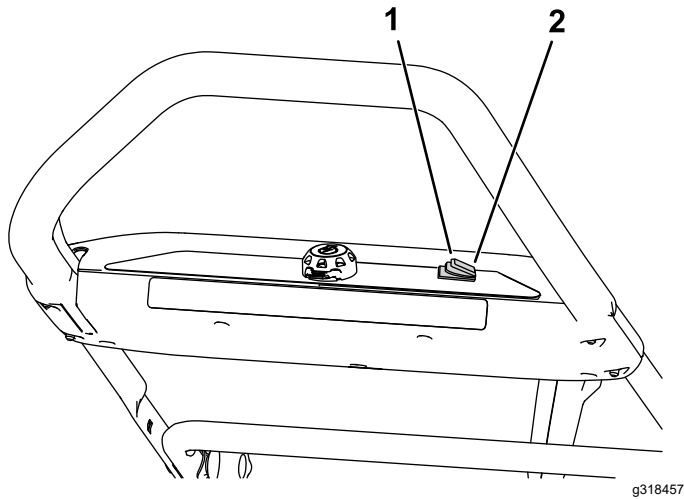

Figure 13

1. Turn ECO mode on
2. Turn ECO mode off

Removing the Battery Pack from the Machine

1. Lift up the battery-compartment lid.
2. Press the battery pack-latch to release the battery pack and remove the battery pack.
3. Close the battery-compartment lid.

Shutting Off the Machine

1. Release the bail (A of [Figure 14](#)).
2. Remove the electric-start button from the electric starter (B of [Figure 14](#)).
3. Remove the battery pack; refer to [Removing the Battery Pack from the Machine](#) (page 13).

Note: Whenever you are not using the appliance, remove the battery pack.

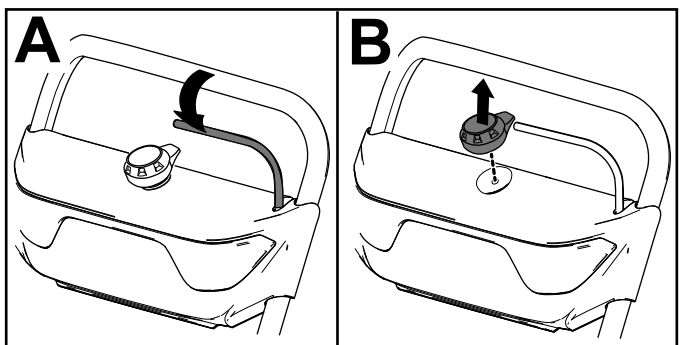

Figure 14

Charging the Battery Pack

Important: The battery pack is not fully charged when you purchase it. Before using the tool for the first time, place the battery pack in the charger and charge it until the LED display indicates the battery pack is fully charged. Read all safety precautions.

Important: Charge the battery pack only in temperatures that are within the appropriate range; refer to [Specifications \(page 11\)](#).

Note: At any time, press the battery-charge-indicator button on the battery pack to display the current charge (LED indicators).

1. Ensure that the vents on the battery and charger are clear of any dust and debris.

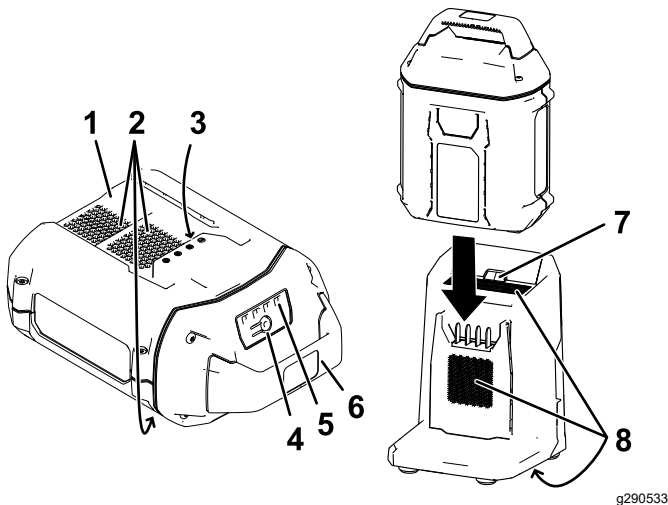

Figure 15

- | | |
|------------------------------------|------------------------------------|
| 1. Battery pack cavity | 5. LED indicators (current charge) |
| 2. Battery pack venting areas | 6. Handle |
| 3. Battery pack terminals | 7. Charger LED indicator light |
| 4. Battery-charge-indicator button | 8. Charger venting areas |
2. Line up the cavity in the battery pack ([Figure 15](#)) with the tongue on the charger.
 3. Slide the battery pack into the charger until it is fully seated ([Figure 15](#)).
 4. To remove the battery pack, slide the battery backward out of the charger.
 5. Refer to the following table to interpret the LED indicator light on the battery charger.

| Indicator light | Indicates |
|-----------------|--------------------------|
| Off | No battery pack inserted |
| Green blinking | Battery pack is charging |

| | |
|--------------|--|
| Green | Battery pack is charged |
| Red | Battery pack and/or battery charger is over or under the appropriate temperature range |
| Red blinking | Battery pack charging fault* |

*Refer to [Troubleshooting \(page 18\)](#) for more information.

Important: The battery can be left on the charger for short periods between uses.

If the battery will not be used for longer periods, remove the battery from the charger; refer to [Storage \(page 17\)](#).

Adjusting the Discharge Chute and Chute Deflector

To adjust the discharge chute, move the handle on the chute-control rod in the direction that you wish to direct the snow stream.

To adjust the chute deflector (and therefore the height of the snow stream), squeeze the trigger and raise or lower the chute deflector (Figure 16).

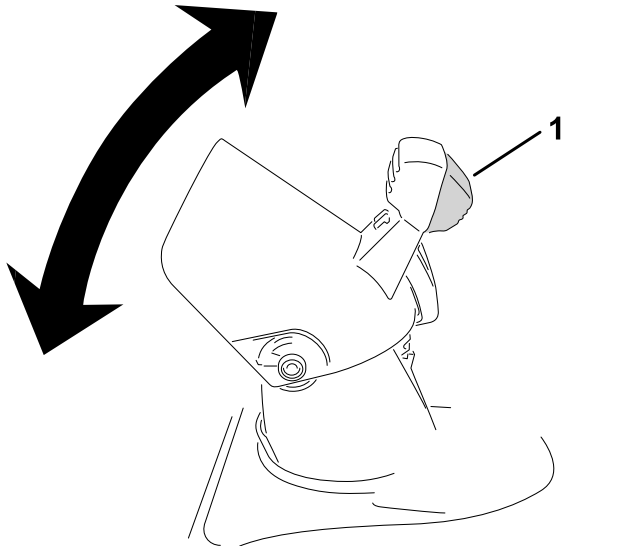

Figure 16

g318452

1. Chute deflector trigger

⚠ WARNING

A gap between the discharge chute and the chute deflector may allow the machine to throw snow and objects in the direction of the operator. Thrown objects could cause serious personal injury.

- Do not force the chute deflector too far forward so that a gap appears between the discharge chute and chute deflector.
- Do not adjust the chute deflector with the power control bar engaged. Release the power control bar before adjusting the chute deflector.

Clearing a Clogged Discharge Chute

⚠ WARNING

Contacting a rotating rotor with your hands inside the discharge chute could cause serious personal injury.

Never use your hands to clean out the discharge chute.

1. Shut off the motor, remove the electric-start button, and remove the battery pack.
2. Wait 10 seconds to ensure that the rotor blades have stopped rotating.
3. Always use a clean-out tool, not your hands, to clear the chute.

Operating Tips

⚠ WARNING

The rotor can throw stones, toys, and other foreign objects and cause serious personal injury to you or bystanders.

- **Keep the area to be cleared free of all objects that the rotor blades could pick up and throw.**
- **Keep all children and pets away from the area of operation.**
- Remove the snow as soon as possible after it falls.
- Push the machine forward, but allow it to work at its own pace.
- Overlap each swath to ensure complete snow removal.
- Discharge the snow downwind whenever possible.

Preventing Freeze-up after Use

- Let the motor run for a few minutes to prevent moving parts from freezing. Shut off the machine, wait for all moving parts to stop, and remove ice and snow from the machine.
- Clean off any snow and ice from the base of the chute.
- Rotate the discharge chute left and right to free it from any ice buildup.
- In snowy and cold conditions, some controls and moving parts may freeze. Do not use excessive force when trying to operate frozen controls. If you have difficulty operating any control or part, start the machine and let it run for a few minutes.

Maintenance

Stop the machine, remove the electric-start button, remove the battery pack from the machine, and wait for all movement to stop before adjusting, servicing, cleaning, or storing the machine.

Replacing the Scraper

Service Interval: Every 20 hours

Replace the scraper blade if it is damaged or if scraping performance is greatly reduced.

When needed, remove and replace the scraper as shown in [Figure 17](#).

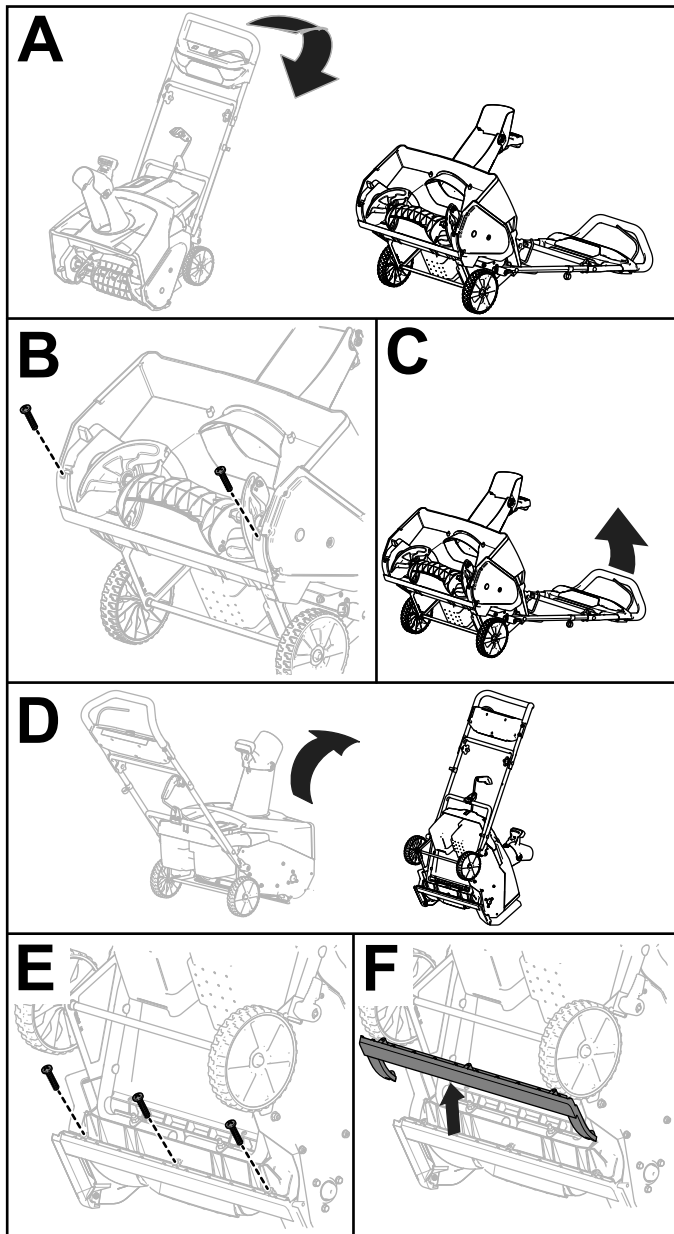

Figure 17

g248009

Storage

Important: Store the machine, battery pack, and charger only in temperatures that are within the appropriate range; refer to [Specifications \(page 11\)](#).

Important: If you are storing the battery pack for the off-season, charge it until 2 or 3 LED indicators turn green on the battery. Do not store a fully charged or fully depleted battery. When you are ready to use the machine again, charge the battery pack until the left indicator light turns green on the charger or all 4 LED indicators turn green on the battery.

- Disconnect the product from the power supply (i.e., remove the plug from the power supply or the battery pack) and check for damage after use.
- Clean all foreign material from the product.
- Do not store the tool with the battery pack installed.
- When not in use, store the machine, battery pack, and battery charger out of the reach of children.
- Keep the machine, battery pack, and battery charger away from corrosive agents, such as garden chemicals and de-icing salts.
- To reduce the risk of serious personal injury, do not store the battery pack outside or in vehicles.
- Store the machine, battery pack, and battery charger in an enclosed clean, dry area.

Preparing the Battery Pack for Recycling

Important: Upon removal, cover the terminals of the battery pack with heavy-duty adhesive tape. Do not attempt to destroy or disassemble the battery pack or remove any of its components.



Lithium-ion battery packs labeled with the Call2Recycle seal can be recycled at any participating retailer or battery recycling facility in the Call2Recycle program (US and Canada only). To locate a participating retailer or facility closest to you, please call 1-800-822-8837 or visit www.call2recycle.org. If you cannot locate a participating retailer or facility nearby, or if your rechargeable battery is not labeled with the Call2Recycle seal, please contact your local municipality for more information on how to responsibly recycle the battery. If you are located outside of the US and Canada, please contact your authorized Toro distributor.

Troubleshooting

Perform only the steps described in these instructions. All further inspection, maintenance, and repair work must be performed by an authorized service center or a similarly qualified specialist if you cannot solve the problem yourself.

| Problem | Possible Cause | Corrective Action |
|---|---|---|
| The machine does not start. | <ol style="list-style-type: none"> 1. The battery is not fully installed in the machine. 2. The battery pack is not charged. 3. The battery pack is damaged. 4. There is another electrical problem with the machine. | <ol style="list-style-type: none"> 1. Remove and then reseat the battery into the machine, making sure that it is fully installed and latched. 2. Remove the battery pack from the machine and charge it. 3. Replace the battery pack. 4. Contact an Authorized Service Dealer. |
| The machine does not reach full power. | <ol style="list-style-type: none"> 1. The battery pack charge capacity is too low. 2. The air vents are blocked. | <ol style="list-style-type: none"> 1. Remove the battery pack from the machine and fully charge the battery pack. 2. Clean the air vents. |
| The battery pack loses charge quickly. | <ol style="list-style-type: none"> 1. The battery pack is over or under the appropriate temperature range. | <ol style="list-style-type: none"> 1. Move the battery pack to a place where it is dry and the temperature is between 5°C (41°F) and 40°C (104°F). |
| The battery charger is not working. | <ol style="list-style-type: none"> 1. The battery charger is over or under the appropriate temperature range. 2. The outlet that the battery charger is plugged into does not have power. | <ol style="list-style-type: none"> 1. Unplug the battery charger and move it to a place where it is dry and the temperature is between 5°C (41°F) and 40°C (104°F). 2. Contact your licensed electrician to repair the outlet. |
| The LED indicator light on the battery charger is red. | <ol style="list-style-type: none"> 1. The battery charger and/or battery pack is over or under the appropriate temperature range. | <ol style="list-style-type: none"> 1. Unplug the battery charger and move the battery charger and battery pack to a place where it is dry and the temperature is between 5°C (41°F) and 40°C (104°F). |
| The LED indicator light on the battery charger is blinking red. | <ol style="list-style-type: none"> 1. There is an error in the communication between the battery pack and the charger. 2. The battery pack is weak. | <ol style="list-style-type: none"> 1. Remove the battery pack from the battery charger, unplug the battery charger from the outlet, and wait 10 seconds. Plug the battery charger into the outlet again and place the battery pack on the battery charger. If the LED indicator light on the battery charger is still blinking red, repeat this procedure again. If the LED indicator light on the battery charger is still blinking red after 2 attempts, properly dispose of the battery pack at a battery recycling facility. 2. Properly dispose of the battery pack at a battery recycling facility. |
| The machine does not run or run continuously. | <ol style="list-style-type: none"> 1. The battery is not fully installed into the machine. | <ol style="list-style-type: none"> 1. Remove and then reseat the battery into the machine making sure that it is fully installed and latched. |

| Problem | Possible Cause | Corrective Action |
|---|--|---|
| The machine is producing a beeping sound. | <ol style="list-style-type: none"> 1. The battery pack is not charged. 2. The machine is in an unsafe position for operation. 3. The machine is overloaded. 4. There is another electrical problem with the machine. | <ol style="list-style-type: none"> 1. Remove the battery pack from the machine and charge it. 2. Ensure that the machine is not at an extreme angle while operating. 3. Walk at a slower pace while clearing snow. 4. Attempt the other troubleshooting actions, if the alarm still sounds, contact an Authorized Service Dealer. |

California Proposition 65 Warning Information

What is this warning?

You may see a product for sale that has a warning label like the following:



WARNING: Cancer and Reproductive Harm—www.p65Warnings.ca.gov.

What is Prop 65?

Prop 65 applies to any company operating in California, selling products in California, or manufacturing products that may be sold in or brought into California. It mandates that the Governor of California maintain and publish a list of chemicals known to cause cancer, birth defects, and/or other reproductive harm. The list, which is updated annually, includes hundreds of chemicals found in many everyday items. The purpose of Prop 65 is to inform the public about exposure to these chemicals.

Prop 65 does not ban the sale of products containing these chemicals but instead requires warnings on any product, product packaging, or literature with the product. Moreover, a Prop 65 warning does not mean that a product is in violation of any product safety standards or requirements. In fact, the California government has clarified that a Prop 65 warning "is not the same as a regulatory decision that a product is 'safe' or 'unsafe.'" Many of these chemicals have been used in everyday products for years without documented harm. For more information, go to <https://oag.ca.gov/prop65/faqs-view-all>.

A Prop 65 warning means that a company has either (1) evaluated the exposure and has concluded that it exceeds the "no significant risk level"; or (2) has chosen to provide a warning based on its understanding about the presence of a listed chemical without attempting to evaluate the exposure.

Does this law apply everywhere?

Prop 65 warnings are required under California law only. These warnings are seen throughout California in a wide range of settings, including but not limited to restaurants, grocery stores, hotels, schools, and hospitals, and on a wide variety of products. Additionally, some online and mail order retailers provide Prop 65 warnings on their websites or in catalogs.

How do the California warnings compare to federal limits?

Prop 65 standards are often more stringent than federal and international standards. There are various substances that require a Prop 65 warning at levels that are far lower than federal action limits. For example, the Prop 65 standard for warnings for lead is 0.5 µg/day, which is well below the federal and international standards.

Why don't all similar products carry the warning?

- Products sold in California require Prop 65 labelling while similar products sold elsewhere do not.
- A company involved in a Prop 65 lawsuit reaching a settlement may be required to use Prop 65 warnings for its products, but other companies making similar products may have no such requirement.
- The enforcement of Prop 65 is inconsistent.
- Companies may elect not to provide warnings because they conclude that they are not required to do so under Prop 65; a lack of warnings for a product does not mean that the product is free of listed chemicals at similar levels.

Why does the manufacturer include this warning?

the manufacturer has chosen to provide consumers with as much information as possible so that they can make informed decisions about the products they buy and use. the manufacturer provides warnings in certain cases based on its knowledge of the presence of one or more listed chemicals without evaluating the level of exposure, as not all the listed chemicals provide exposure limit requirements. While the exposure from the manufacturer products may be negligible or well within the "no significant risk" range, out of an abundance of caution, the manufacturer has elected to provide the Prop 65 warnings. Moreover, if the manufacturer does not provide these warnings, it could be sued by the State of California or by private parties seeking to enforce Prop 65 and subject to substantial penalties.