



44" Snowthrower
Wheel Horse[®] 5xi Garden Tractor Attachment
Model No. 79366—21000001 and Up

Operator's Manual

Contents

	Page
Introduction	2
Safety	3
General Snowthrower Safety	3
Preparation	3
Operation	3
Maintenance and Storage	4
Toro Snowthrower Safety	4
Safety and Instruction Decals	4
Installation	5
Loose Parts	5
Assembling the Snowthrower	6
Setting Up the Tractor	7
Installing the Snowthrower on the Tractor	8
Removing the Snowthrower	12
Operation	14
Operating the Snowthrower	15
Raising and Lowering the Snowthrower	15
Adjusting the Discharge Chute	16
Tips for Throwing Snow	16
Maintenance	17
Recommended Maintenance Schedule	17
Greasing and Lubrication	17
Replacing the Snowthrower Belt	19
Adjusting the Skids	21
Replacing the Scraper Blade	21
Adjusting the Drive Chain Tension	22
Storage	22

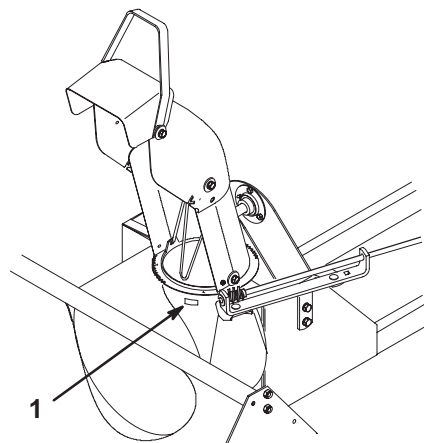

m-3732

Figure 1

1. Model and serial number plate

For your convenience, write the product model and serial numbers in the space below.

<p>Model No.: _____</p> <p>Serial No.: _____</p>
--

Read this manual carefully to learn how to operate and maintain your product correctly. Reading this manual will help you and others avoid personal injury and damage to the product. Although we design, produce and market safe, state-of-the-art products, you are responsible for using the product properly and safely. You are also responsible for training persons, who you allow to use the product, about safe operation.

The warning system in this manual identifies potential hazards and has special safety messages that help you and others avoid personal injury, even death. **Danger**, **Warning**, and **Caution** are signal words used to identify the level of hazard. However, regardless of the hazard, be extremely careful.

Danger signals an extreme hazard that will cause serious injury or death if the recommended precautions are not followed.

Warning signals a hazard that may cause serious injury or death if the recommended precautions are not followed.

Caution signals a hazard that may cause minor or moderate injury if the recommended precautions are not followed.

Two other words are also used to highlight information. **Important** calls attention to special mechanical information, and **Note** emphasizes general information worthy of special attention.

Introduction



Thank you for purchasing a Toro product.

All of us at Toro want you to be completely satisfied with your new product, so feel free to contact your local Authorized Service Dealer for help with service, genuine replacement parts, or other information you may require.

Whenever you contact your Authorized Service Dealer or the factory, always know the model and serial numbers of your product. These numbers will help the Service Dealer or Service Representative provide exact information about your specific product. You will find the model and serial number plate at the location shown in Figure 1.



Safety

Improper use or maintenance by the operator or owner can result in injury. To reduce the potential for injury, comply with the safety instructions in the traction unit operator's manual and always pay attention to the safety alert  symbol, which means CAUTION, WARNING, or DANGER—"personal safety instruction." Failure to comply with the instruction may result in personal injury or death.

 **Danger** 

When the snowthrower is in operation, the impeller and auger can be rotating and cut off or injure hands and feet.

- Before adjusting, cleaning, repairing and inspecting the snowthrower, and before unclogging the discharge chute, *move the PTO to the off position, stop the engine, and wait for all moving parts to stop. Remove the key.*
- Use a stick, *not your hands*, to remove an obstruction from the discharge chute.
- Stay behind the handles and away from the discharge opening while operating the snowthrower.
- Keep face, hands, feet, and any other part of your body or clothing away from concealed, moving, or rotating parts.

 **Warning** 

The auger/impeller may pick up and throw stones, toys, and other foreign objects, causing serious personal injury to the operator or to bystanders.

- Keep the area to be cleared free of all objects that could be picked up and thrown by the auger/impeller.
- Keep all children and pets away from area of operation.

General Snowthrower Safety

The following instructions have been adapted from the ANSI/OPEI and ISO standards.

Preparation

- Thoroughly inspect the area where the equipment is to be used and remove all doormats, sleds, boards, wires, and other foreign objects.

- Do not operate the equipment without wearing adequate winter outer garments. Wear footwear that will improve footing on slippery surfaces.
- Adjust the auger housing height to clear gravel or crushed rock surface.
- Never attempt to make any adjustments while the engine is running, except when specifically recommended by Toro.
- Let engine and machine adjust to outdoor temperatures before starting to clear snow.
- The operation of any powered machine can result in foreign objects being thrown into the eyes. Always wear safety glasses or eye shields during operation or while performing an adjustment or repair.

Operation

- Do not put hands or feet near or under rotating parts. Keep clear of the discharge opening at all times.
- Exercise extreme caution when operating on or crossing gravel drives, walks, or roads. Stay alert for hidden hazards or traffic. Do not carry passengers.
- After striking a foreign object, stop the engine, remove the wire(s) from the spark plug(s), thoroughly inspect the snowthrower for any damage, and repair the damage before restarting and operating the snowthrower.
- If the unit should start to vibrate abnormally, stop the engine and check immediately for the cause. Vibration is generally a warning of trouble.
- Stop the engine whenever you leave the operating position, before unclogging the auger/impeller housing or discharge chute, and when making any repairs, adjustments, or inspections.
- When cleaning, repairing, or inspecting, make certain the auger/impeller and all moving parts have stopped. Disconnect the spark plug wire(s) and keep the wire away from the plug to prevent someone from accidentally starting the engine.
- Do not clear snow across the face of slopes. Exercise extreme caution when changing direction on slopes. Do not attempt to clear steep slopes.
- Never operate the snowthrower without proper guards, plates, or other safety protective devices in place.
- Never operate the snow thrower near glass enclosures, automobiles, window wells, drop-offs, and the like without proper adjustment of the snow discharge angle. Keep children and pets away.
- Do not overload the machine capacity by attempting to clear snow at too fast a rate.

- Never operate the machine at high transport speeds on slippery surfaces. Look behind and use care when moving in reverse.
- Never direct discharge at bystanders or allow anyone in front of the unit.
- Disengage power to the auger/impeller when the snowthrower is transported or not in use.
- Never operate the snowthrower without good visibility or light.

Maintenance and Storage

- Check fasteners at frequent intervals for proper tightness to be sure the equipment is in safe working condition.
- Always refer to the operator's manual for important details if the snowthrower is to be stored for an extended period.
- Maintain or replace safety and instruction labels, as necessary.
- Run the machine a few minutes after throwing snow to prevent freeze-up of the auger/impeller.

Toro Snowthrower Safety

The following list contains safety information specific to Toro products or other safety information that you must know that is not included in the ANSI or ISO standards.

- **The rotating auger/impeller or rotor blades can cut off or injure fingers or hands.** Stay in the operator's position and away from the discharge opening while

operating the snowthrower. **Keep your face, hands, feet, and any other part of your body or clothing away from concealed, moving, or rotating parts.**

- Before adjusting, cleaning, repairing, and inspecting the snowthrower, and before unclogging the discharge chute, **stop the engine, remove the key, and wait for all moving parts to stop.** Also, pull the wire(s) off of the spark plug(s) and keep it away from the plug(s) to prevent someone from accidentally starting the engine.
- Use a stick, **not your hands** to remove obstructions from the discharge chute.
- **Before** leaving the operator's position, stop the engine, remove the key, and wait for all moving parts to stop.
- Do not wear loose fitting clothing that could possibly get caught in moving parts.
- If a shield, safety device, or decal is damaged, illegible, or lost, repair or replace it before beginning operation. Also, tighten any loose fasteners.
- **Do not** use the snowthrower on a roof.
- Perform only those maintenance instructions described in this manual. Before performing any maintenance, service, or adjustment, stop the engine, remove the key and pull the wire(s) from the spark plug(s), keeping it away from the plug(s) to prevent someone from accidentally starting the engine. If major repairs are ever needed, contact your Authorized Toro Service Dealer.
- To ensure the best performance and safety, purchase only genuine Toro replacement parts and accessories to keep the Toro all Toro. **Do not use "Will Fit" replacement parts and accessories as they could cause a safety hazard.**

Safety and Instruction Decals



Safety decals and instructions are easily visible to the operator and are located near any area of potential danger. Replace any decal that is damaged or lost.

Two on the Upper Discharge Chute (Part No. 94-8079)



On Top of the Housing (Part No. 92-8652)



Two on Top of the Housing (Part No. 63-2380)



On Top of the Pulley Cover (Part No. 98-8705)



Installation

Note: Determine the left and right side of the machine from the normal operating position.

Note: To use the snowthrower with your tractor, you must have a rear-mount Attach-A-Matic™ hitch, rear wheel weights and chains, all of which must be purchased separately. If you will be using the snowthrower on slopes or in very slippery conditions, purchase a rear weight box instead of the rear wheel weights.

Loose Parts

DESCRIPTION	QTY.	USE
Snowthrower frame assembly	1	Attaching the lift tube
Lift tube	1	
Clevis pin, 1/2 x 2-5/8 in. (67 mm)	1	
Clevis clip	1	
Discharge chute assembly	1	Assembling the discharge chute
Washer, 5/16 in. (8 mm)	3	
Locknut, 5/16 in.	3	
Carriage bolt, 5/16-18 x 3/4 in. (19 mm)	3	
Clevis pin, 3/8 x 1 in. (25 mm)	2	Preparing the tractor attachment lift
Hairpin cotter, small	2	
Pulley box	1	Installing the pulley box
Belt	1	
Clevis pin, 1/2 x 1 in. (25 mm)	1	Mounting the snowthrower to the tractor
Clevis clip	1	
Spring tension link	1	
Support rod link	1	
Support brace	2	
Washer, 13/16 in. (21 mm)	2	
Hairpin cotter, large	4	
Washer, 15/16 in. (24 mm)	2	
Crank support	1	
Locking pin	1	
Chute control rod	1	
Hairpin cotter, small	3	
Hairpin cotter, medium	1	
Pulley cover	1	
Screw, #10 x 1/2 in. (13 mm)	4	
Rod Assembly	1	
Spacer washer, 1 in. (25 mm)	5	
C-pin	2	

Assembling the Snowthrower

Attaching the Lift Tube

Connect the lift tube to the snowthrower frame assembly using a 1/2 x 2-5/8 in. (67 mm) clevis pin and clip (Fig. 1).

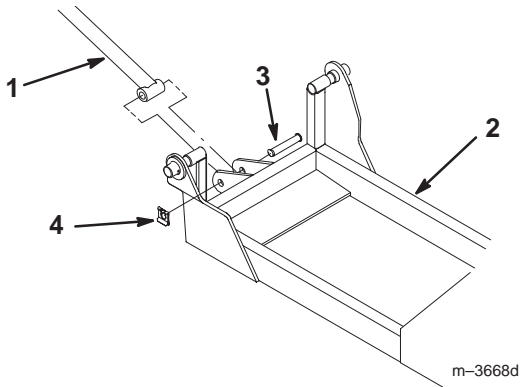

Figure 1

- | | |
|-------------------------------|--|
| 1. Lift tube | 3. Clevis pin, 1/2 x 2-5/8 in. (67 mm) |
| 2. Snowthrower frame assembly | 4. Clevis clip |

Assembling the Discharge Chute

Install the discharge chute assembly onto the chute ring with three, 5/16 x 3/4 in. (19 mm) carriage bolts (heads to the inside); three, 5/16 in. (8 mm) washers; and three, 5/16 in. locknuts (Fig. 2).

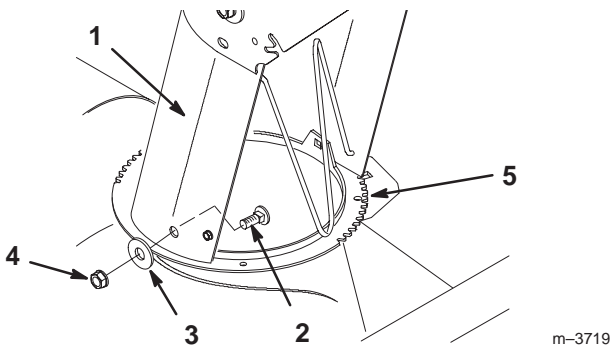

Figure 2

- | | |
|--|----------------------------|
| 1. Discharge chute assembly | 3. Washer, 5/16 in. (8 mm) |
| 2. Carriage bolt, 5/16 x 3/4 in. (19 mm) | 4. Locknut, 5/16 in. |
| | 5. Chute ring |

Verifying the Drive Chain Tension

Verify that the drive chain has between 1/8 and 1/2 in. deflection in the area shown in Figure 3. If the chain is too tight or too loose, adjust it; refer to Adjusting the Drive Chain Tension, page 22.

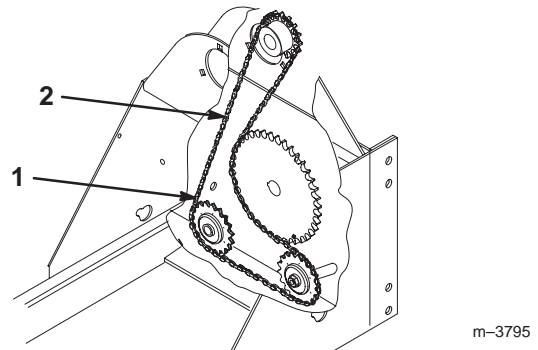

Figure 3

- | | |
|----------------|--------------------------|
| 1. Drive chain | 2. Check deflection here |
|----------------|--------------------------|

Assembling the Spring Tension Link

Insert the hooked end of the spring tension link into the open hole in the outer leg of the spring tension lever (Fig. 4).

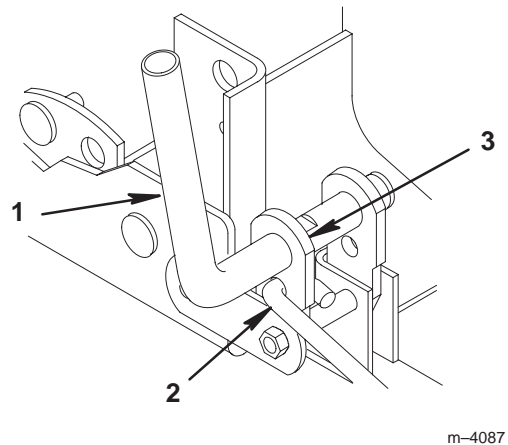

Figure 4

- | | |
|--------------------------------------|--------------|
| 1. Spring tension lever | 3. Outer leg |
| 2. Hooked end of spring tension link | |

Installing the Drive Belt and Pulley Cover

1. Route the belt under the four pulleys and inside the belt guide in the pulley box (Fig. 5).

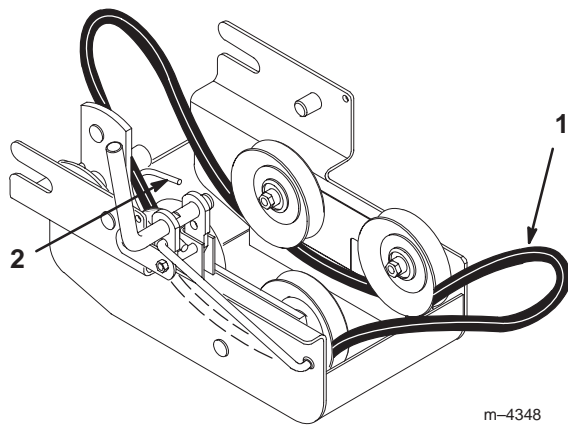

Figure 5

1. Snowthrower belt
2. Belt guide

2. Slide the pulley box into the snowthrower frame (Fig. 6).
3. Route the belt over the snowthrower pulley (Fig. 6).

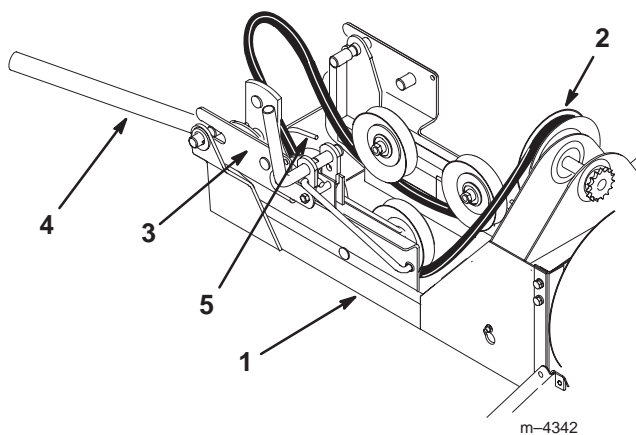

Figure 6

1. Snowthrower frame
2. Snowthrower pulley
3. Pulley box
4. Lift tube
5. Belt guide

4. Ensure that the wide side of the PTO drive belt is toward the outside diameter of **all the pulleys** (Fig. 7).

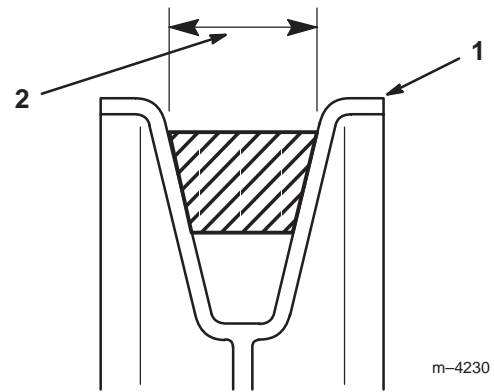

Figure 7

1. Pulley outside diameter
2. Wide side of belt

5. Attach the pulley cover to the snowthrower frame assembly with four, #10 x 1/2 in. (13 mm) screws (Fig. 8).

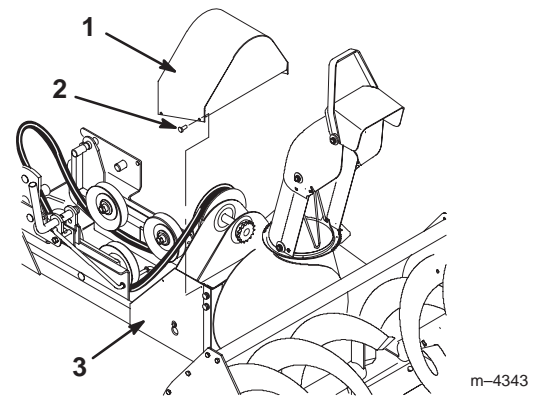

Figure 8

1. Pulley cover
2. Screw, #10 x 1/2 in. (13 mm)
3. Snowthrower frame assembly

Setting Up the Tractor

Installing the Rear Attach-A-Matic Hitch, Rear Wheel Weights, and Chains

Install the rear Attach-A-Matic hitch, the rear wheel weights, and chains according to the instructions supplied with them.

Note: If you will be using the snowthrower on slopes or in very slippery conditions, purchase and install a rear weight box instead of the rear wheel weights.

Preparing the Attachment Lift

1. Start the engine.

2. Raise the attachment lift.
3. Set the parking brake, stop the engine, and remove the ignition key.
4. Secure the lift arms to the tractor frame with two, 3/8 x 1 in. (25 mm) clevis pins and two small hairpin cotters (Fig. 9).

Note: The two lift arms are located on the tractor frame, just ahead of the rear wheels.

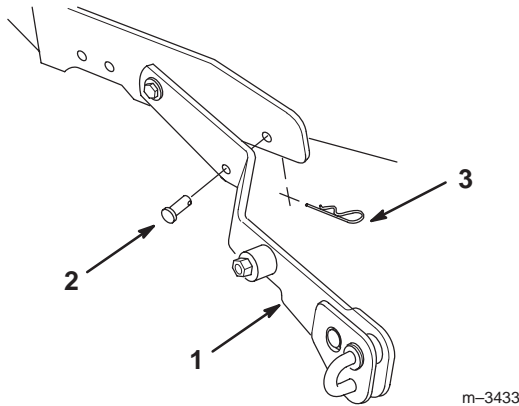

Figure 9

Right side of tractor shown

- | | |
|------------------------------------|--------------------------|
| 1. Lift arm | 3. Hairpin cotter, small |
| 2. Clevis pin, 3/8 x 1 in. (25 mm) | |

Important Remove the pins when attaching a mower.

Installing the Snowthrower on the Tractor

Connecting the Snowthrower to the Front Attach-A-Matic Hitch

1. Position the snowthrower frame assembly and its attachment parts on a level surface with enough space behind them to accommodate the tractor.
2. Park the tractor behind the snowthrower with the front wheels lined up to straddle the snowthrower frame and lift rod (Fig. 10).

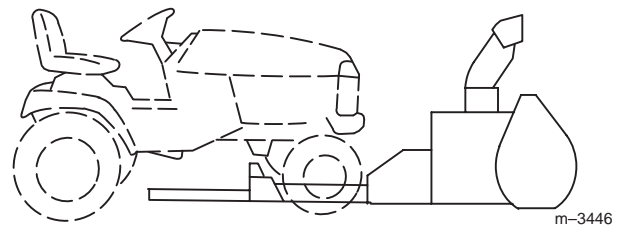

Figure 10

3. Lower the attachment lift, stop the engine, and remove the ignition key.
4. With the high-low range selector in neutral (N), pull the tractor forward toward the snowthrower until the end of the snowthrower frame is just underneath the tractor's front Attach-A-Matic hitch (Fig. 11).

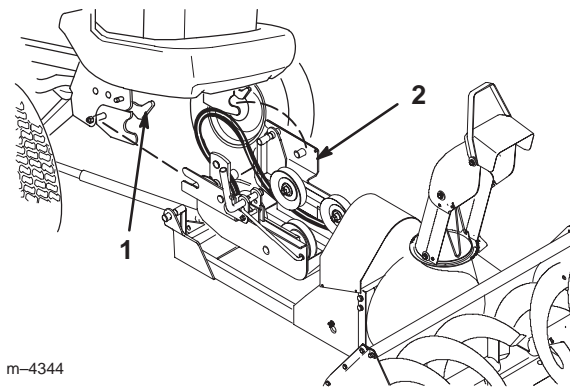

Figure 11

- | | |
|---------------------------------|---------------|
| 1. Attach-A-Matic hitch latches | 2. Pulley box |
|---------------------------------|---------------|

5. Ensure the latches on the front Attach-A-Matic hitch are open (Fig. 11).
6. Slide the pulley box completely into the hitch (Fig. 11).
7. Close the latches by rotating them down (Fig. 11).
8. Install two C-pins into the locking holes of the pulley box (Fig. 12).
9. Secure the pins with two small hairpin cotters on the inside (Fig. 12).

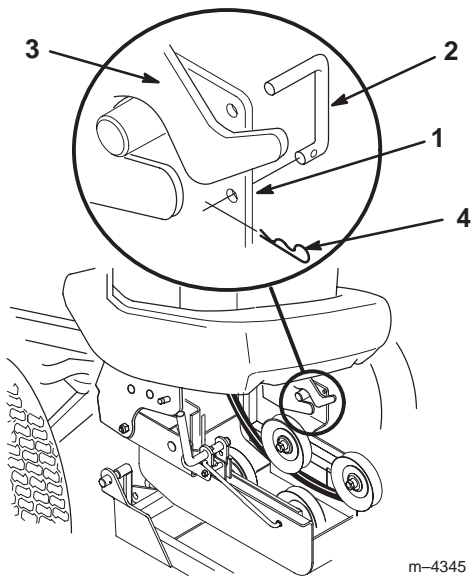

Figure 12

- | | |
|---------------|--------------------------|
| 1. Pulley box | 3. Attach-A-Matic latch |
| 2. C-pin | 4. Hairpin cotter, small |

Connecting the Snowthrower to the Mid Attach-A-Matic Hitch

1. Pull the tractor toward the snowthrower until the snowthrower frame connecting pins are directly below the mid Attach-A-Matic hitch (Fig. 13)

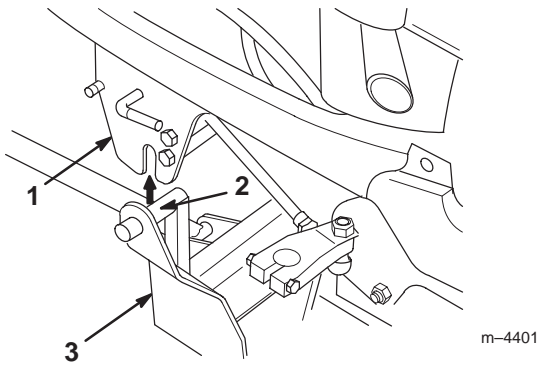

Figure 13

Right side of tractor shown

- | | |
|---|----------------------|
| 1. Mid Attach-A-Matic hitch | 3. Snowthrower frame |
| 2. Snowthrower connecting pins (right side shown) | |

2. Ensure that the mid Attach-A-Matic hitch latches are open.
3. Slide the round end of the crank support under the notch in the snowthrower frame (Fig. 14).

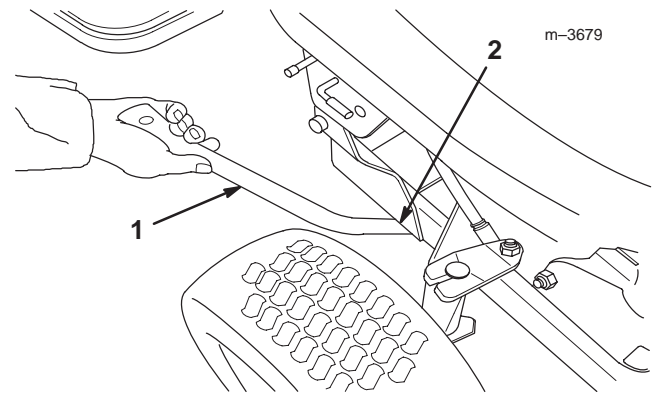

Figure 14

Right side of tractor shown

- | | |
|------------------|-------------------------------|
| 1. Crank Support | 2. Notch in snowthrower frame |
|------------------|-------------------------------|

4. Use the crank support as a lever to lift the snowthrower frame until its connecting pins are completely inside the notches in the mid Attach-A-Matic hitch (Fig. 15).

Warning

The snowthrower is heavy and can injure hands or feet if it falls on them.

Keep your hands and feet away from the underside of the snowthrower frame.

5. Turn the mid Attach-A-Matic hitch lever counterclockwise to lock the snowthrower in place (Fig. 15).

Important Ensure that the snowthrower frame is locked in place. You should hear a distinct click if the snowthrower is correctly mounted.

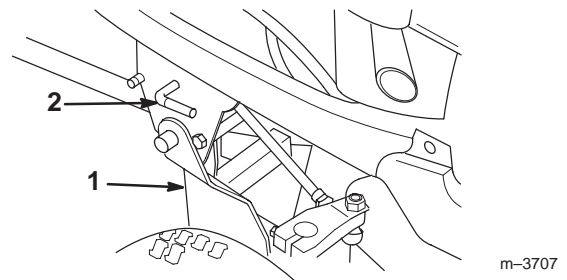

Figure 15

Right side of tractor shown

- | | |
|----------------------|-----------------------------------|
| 1. Snowthrower frame | 2. Mid Attach-A-Matic hitch lever |
|----------------------|-----------------------------------|

Connecting the Lift Rod

1. Set the parking brake.
2. Add two 1 in (25 mm) washers onto the end of the lift rod assembly, then slide it into the lift tube (Fig. 16).

Important The washers (Fig. 16) adjust how low the snowthrower can drop below grade. If the snowthrower drops too low, the drive belt can lose tension and slip. Add washers, as needed, to prevent this problem.

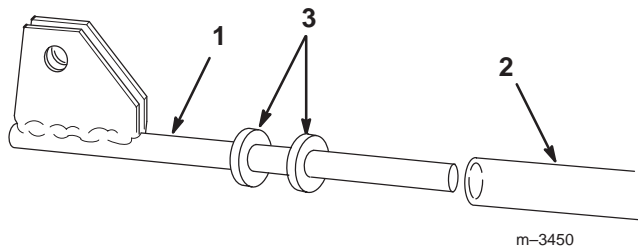

Figure 16

- | | |
|----------------------|---------------------------|
| 1. Lift rod assembly | 3. Washers, 1 in. (25 mm) |
| 2. Lift tube | |

3. Lift the front of the snowthrower and support it securely so that the scraper is 1 to 2 in. off the ground.
4. From beneath the tractor, connect the lift rod assembly to the middle hole in the attachment lift plate with the 1/2 x 1 in. (25 mm) clevis pin and clip (Fig. 17).

Note: The lift plate goes between the lift rod assembly plates.

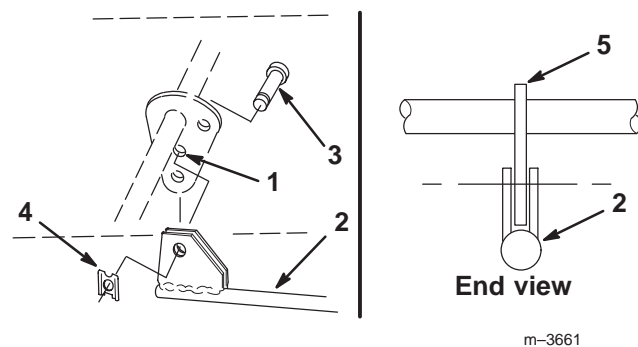

Figure 17

Right side of tractor shown

- | | |
|---|------------------------------------|
| 1. Middle hole in attachment lift plate | 3. Clevis pin, 1/2 x 1 in. (25 mm) |
| 2. Snowthrower rod assembly | 4. Clevis clip |
| | 5. Attachment lift plate |

Installing the Belt to the Engine PTO Pulley

1. Open the hood of the tractor
2. Remove the right-hand side panel.



Caution



Components under the hood will be hot if the tractor has been running. If you touch hot components you may be burned.

Allow the tractor to cool before performing maintenance or touching components under the hood.

3. Route the snowthrower belt around the engine PTO pulley (Fig. 18).

Note: Lifting up on the spring-loaded pulley will ease installation of the belt.

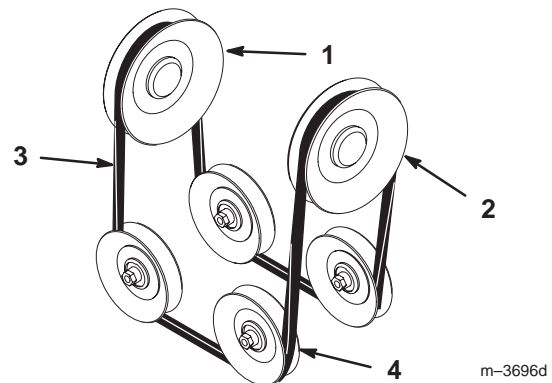

Figure 18

- | | |
|-----------------------|-------------------------|
| 1. Engine PTO pulley | 3. Belt |
| 2. Snowthrower pulley | 4. Spring-loaded pulley |

4. Ensure that the wide side of the PTO drive belt is toward the outside diameter of all six pulleys (Fig. 19).

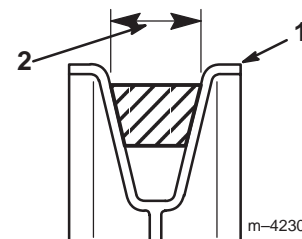

Figure 19

- | | |
|----------------------------|----------------------|
| 1. Pulley outside diameter | 2. Wide side of belt |
|----------------------------|----------------------|

5. Replace the right side panel and close the hood.

- On the right side of the tractor, pull forward on the spring tension lever and connect the spring tension link to the keyhole slot in the snowthrower frame (Fig. 20).

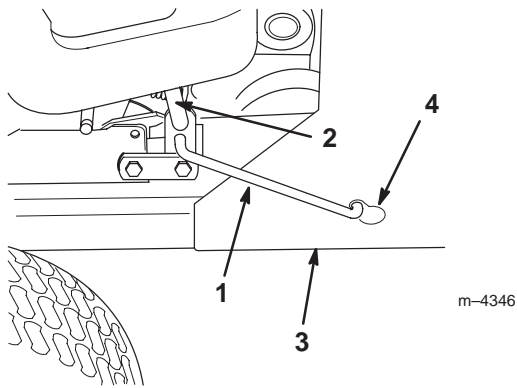

Figure 20

Right side of tractor shown

- | | |
|-------------------------|----------------------|
| 1. Spring tension link | 3. Snowthrower frame |
| 2. Spring tension lever | 4. Keyhole slot |

Securing the Rear of the Snowthrower

- Open the latches on the rear Attach-A-Matic hitch.
- Put the support rod link into the front notches on the rear Attach-A-Matic hitch and close the latches to secure it in place (Fig. 21).

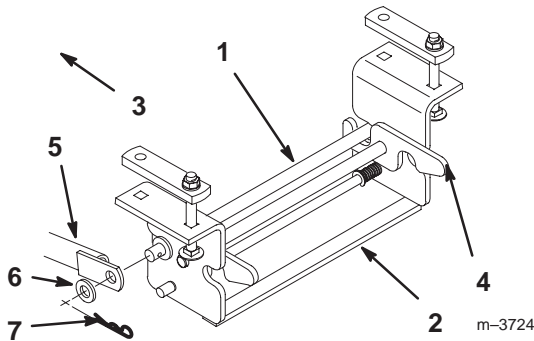

Figure 21

- | | |
|------------------------------------|------------------------------|
| 1. Support rod link | 5. Support brace |
| 2. Rear Attach-A-Matic hitch | 6. Washer, 13/16 in. (21 mm) |
| 3. Front of tractor | 7. Hairpin cotter, large |
| 4. Rear Attach-A-Matic hitch latch | |

- Slide the non adjusting ends of the two support braces onto the support rod link that is now in the rear Attach-A-Matic hitch mount, ensuring that the rod on each brace faces inward.
- Secure the braces to the rod with a 13/16 in. (21 mm) washer and a large hairpin cotter (Fig. 21).

- Secure the other ends of the support braces to the frame rods protruding from the mid Attach-A-Matic hitch with a 15/16 in. (24 mm) washer and a large hairpin cotter (Fig. 22).

Note: You may need to turn the adjuster of each brace before the holes in the adjuster align with the frame rod.

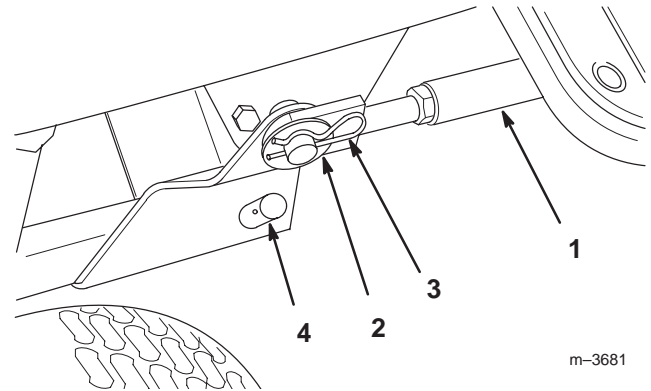

Figure 22

Left side of tractor shown

- | | |
|-----------------------------|------------------------------------|
| 1. Support brace | 4. Mounting post for crank support |
| 2. Washer, 15/16 in. (24mm) | |
| 3. Hairpin cotter, large | |

Installing the Chute Crank

- Slide the crank support onto the mounting post on the left-hand side of the tractor (Fig. 22).
- Secure the crank support in position with a locking pin and small hairpin cotter (Fig. 23).

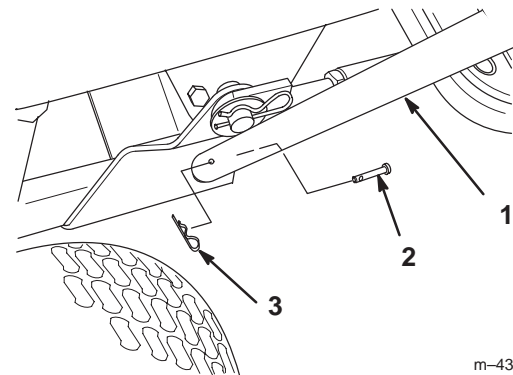

Figure 23

Left side of tractor shown

- | | |
|------------------|--------------------------|
| 1. Crank support | 3. Hairpin cotter, small |
| 2. Locking pin | |
- Slide the chute control rod through the hole in the end of the crank support (Fig. 24).

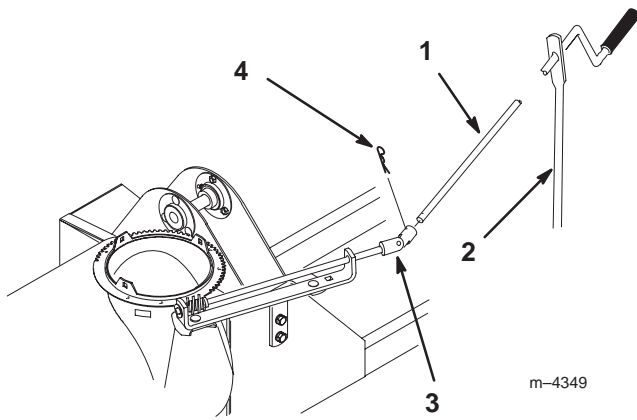

Figure 24

- | | |
|----------------------|---------------------------|
| 1. Chute control rod | 3. Universal joint |
| 2. Crank support | 4. Hairpin cotter, medium |

4. Connect the end of the chute control rod to the universal joint on the snowthrower with a medium hairpin cotter (Fig. 24).

Removing the Snowthrower

Removing the Belt

1. Park the tractor on a level surface, lower the attachment lift, disengage the PTO, set the parking brake, stop the engine, and remove the ignition key.
2. Relieve the snowthrower belt tension by pulling the spring tension lever forward until you have enough slack to disconnect the link from the keyhole slot (Fig. 25).

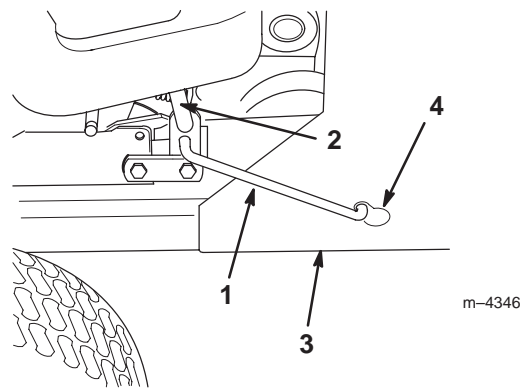

Figure 25

Right side of tractor shown

- | | |
|-------------------------|----------------------|
| 1. Spring tension link | 3. Snowthrower frame |
| 2. Spring tension lever | 4. Keyhole slot |

3. Connect the end of the chute control rod to the universal joint on the snowthrower with a medium hairpin cotter (Fig. 24).
4. Open the hood of the tractor
5. Remove the right-hand side panel.

⚠
Caution
⚠

Components under the hood will be hot if the tractor has been running. If you touch hot components you may be burned.

Allow the tractor to cool before performing maintenance or touching components under the hood.

6. Remove the snowthrower belt from around the engine PTO pulley (Fig. 26).

Note: Lifting up on the spring-loaded pulley will ease removal of the belt.

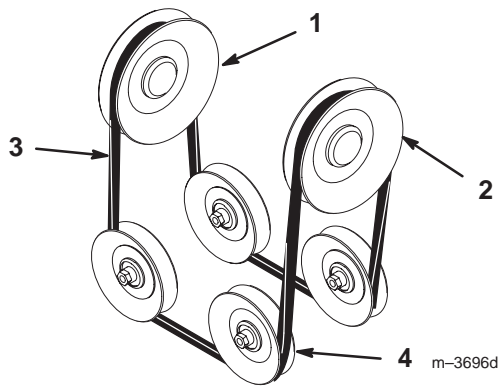

Figure 26

- | | |
|-----------------------|-------------------------|
| 1. Engine PTO pulley | 3. Belt |
| 2. Snowthrower pulley | 4. Spring-loaded pulley |

7. Replace the right side panel and close the hood.

Removing the Chute Crank

1. Remove the chute control rod by removing the hairpin cotter connecting it to the universal joint (Fig. 27).

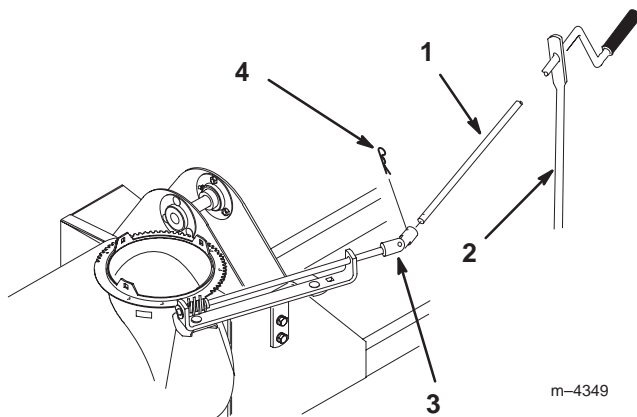

Figure 27

- | | |
|----------------------|---------------------------|
| 1. Chute control rod | 3. Universal joint |
| 2. Crank support | 4. Hairpin cotter, medium |

2. Slide the chute control rod out of the end of the crank support (Fig. 27).

3. Remove the crank support by removing the hairpin cotter and clevis pin at its base (Fig. 28), then lifting the support from its mounting post.

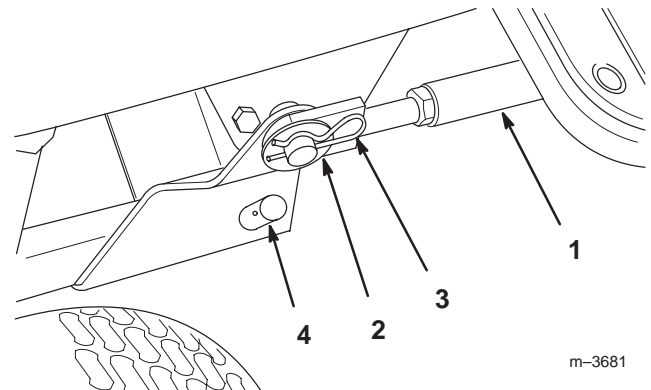

Figure 28

Left side of tractor shown

- | | |
|-----------------------------|------------------------------------|
| 1. Support brace assembly | 4. Mounting post for crank support |
| 2. Washer, 15/16 in. (24mm) | |
| 3. Hairpin cotter, large | |

Disconnecting the Rear of the Snowthrower

1. Remove the support braces from the frame rods protruding from the mid Attach-A-Matic hitch by removing the hairpin cottes and washers (Fig. 28).

2. Remove the other ends of the two support braces from the rear Attach-A-Matic hitch mount by removing the hairpin cottes and washers (Fig. 29).

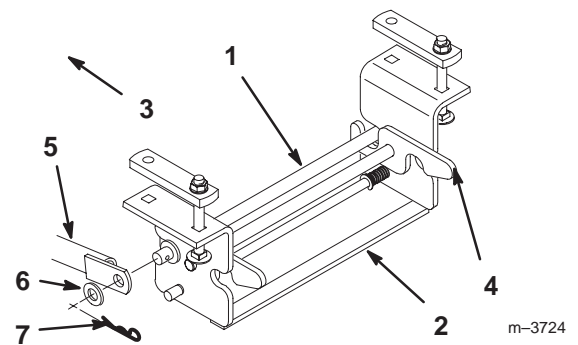

Figure 29

- | | |
|------------------------------------|------------------------------|
| 1. Support rod link | 5. Support brace |
| 2. Rear Attach-A-Matic hitch | 6. Washer, 13/16 in. (21 mm) |
| 3. Front of tractor | 7. Hairpin cotter, large |
| 4. Rear Attach-A-Matic hitch latch | |

3. Release the latches on the rear Attach-A-Matic hitch and remove the support rod link (Fig. 29).

Disconnecting the Lift Rod

Disconnect the lift rod from the attachment lift plate by removing the clevis clip and clevis pin (Fig. 30).

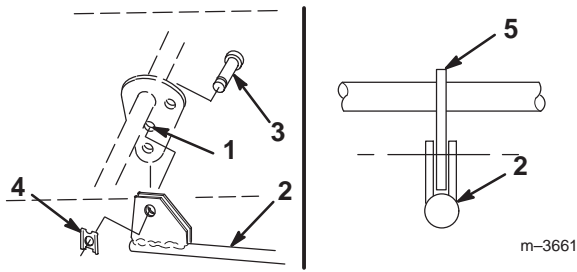

Figure 30

Right side of tractor shown

- | | |
|---|--------------------------|
| 1. Middle hole in attachment lift plate | 4. Clevis clip |
| 2. Snowthrower lift rod | 5. Attachment lift plate |
| 3. Clevis pin, 1/2 x 1 in. (25 mm) | |

Disconnecting the Snowthrower

1. Press the button of the mid Attach-A-Matic hitch and carefully turn the lever clockwise to release the snowthrower (Fig. 31).

The snowthrower frame will drop to the ground.

Warning

The snowthrower is heavy and can injure hands or feet if it falls on them.

Keep your hands and feet away from the underside of the snowthrower frame.

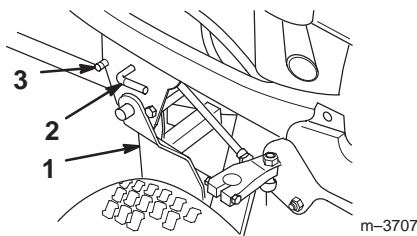

Figure 31

Right side of tractor shown

- | | |
|-----------------------------------|------------------------------------|
| 1. Snowthrower frame | 3. Mid Attach-A-Matic hitch button |
| 2. Mid Attach-A-Matic hitch lever | |

2. Put the high-low range lever in neutral (N) and release the parking brake.
3. Push the tractor back, away from the snowthrower until there is sufficient space to remove the pulley box.
4. Remove the C-pins from the pulley box locking holes (Fig. 32).
5. Open the latches of the front Attach-A-Matic hitch, remove the pulley box, and slide it into snowthrower frame.
6. Install the C-pins into the locking holes of the pulley box for storage, securing them with the hairpin cotters.

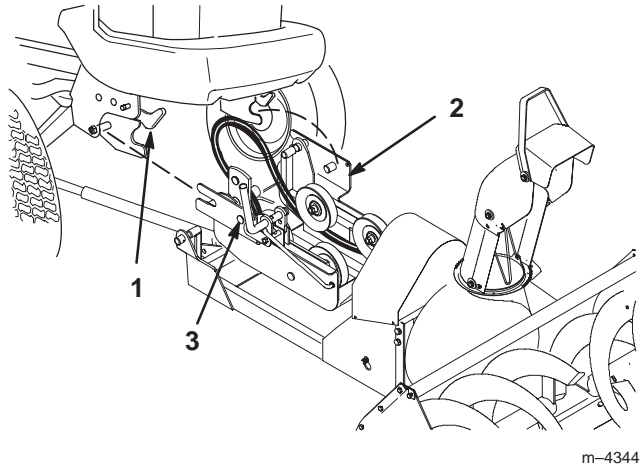

Figure 32

- | | |
|---------------------------------|------------------|
| 1. Attach-A-Matic hitch latches | 2. Pulley box |
| | 3. Locking holes |

7. Push the tractor back, away from the snowthrower frame and set the parking brake.

Operation

Danger

If you attach the snowthrower to the tractor without adding weight to the rear of the tractor, the tractor may become unstable and could tip over, crushing you or bystanders. You may also lose control of the tractor.

Do not operate the snowthrower without first installing rear wheel weights or a rear weight box.



Danger



When the snowthrower is in operation, the impeller and auger can be rotating and cut off or injure hands and feet.

- Before adjusting, cleaning, repairing and inspecting the snowthrower, and before unclogging the discharge chute, *move the PTO to the off position, stop the engine, and wait for all moving parts to stop. Remove the key.*
- Use a stick, *not your hands*, to remove an obstruction from the discharge chute.
- Stay behind the handles and away from the discharge opening while operating the snowthrower.
- Keep face, hands, feet, and any other part of your body or clothing away from concealed, moving, or rotating parts.

Operating the Snowthrower

The power take off (PTO) runs the snowthrower. If the ignition key is in the run or lights position and the PTO is engaged, the PTO indicator light will be on. When this light is on, it is a reminder: the implement is being powered and the starter will not crank while the PTO is engaged. Always turn off the PTO before getting off the seat.

Engaging the PTO

1. Press the brake pedal to stop the machine.
2. Move the throttle lever to the fast position.

Important For best performance, always use full throttle when the PTO is on.

3. Pull the PTO switch to the on position (Fig. 33).

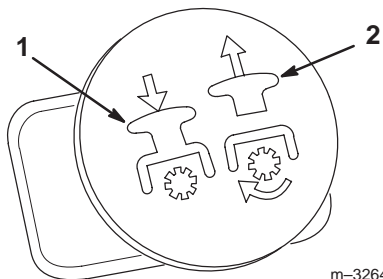

m-3264

Figure 33

1. Push (off-disengaged)
2. Pull (on-engaged)

Disengaging the PTO

Push the PTO switch to the off position.

Note: Determine the left and right side of the machine from the normal operating position.

Raising and Lowering the Snowthrower

Raise and lower the snowthrower using the attachment power lift lever. This lever is located to the right of the steering wheel (Fig. 34).

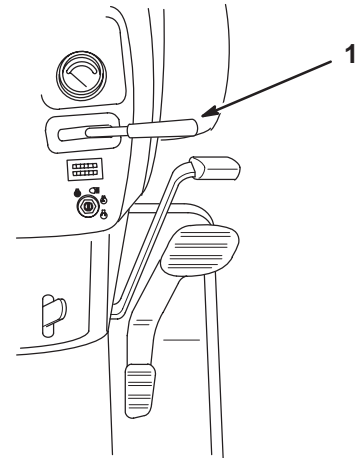

m-3258

Figure 34

1. Attachment power lift lever

Raising the Snowthrower

1. Start the tractor.
2. Pull the lift lever up (Fig. 35).

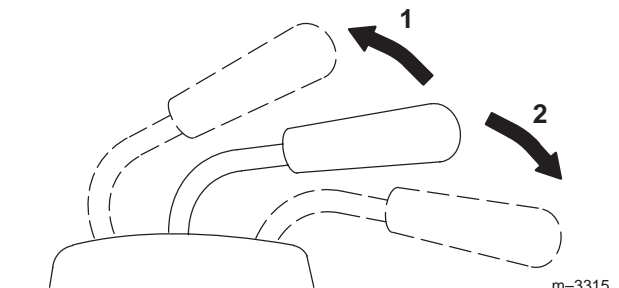

m-3315

Figure 35

1. Lift lever, Up
2. Lift lever, Down

3. Release the lever when the snowthrower has reached the desired height.

The snowthrower will remain in the raised position until you lower it again.



Warning



When the engine is off, attachments in the raised position may gradually lower, possibly pinning or injuring you or a bystander.

Lower the attachment lift before stopping the engine.

Lowering the Snowthrower

1. Start the tractor.
2. Push the lift lever down (Fig. 35).

Adjusting the Discharge Chute



Danger



When the snowthrower is in operation, the impeller and auger can be rotating and cut off or injure hands and feet.

- Before adjusting, cleaning, repairing and inspecting the snowthrower, and before unclogging the discharge chute, move the PTO to the off position, stop the engine, and wait for all moving parts to stop. Remove the key.
- Use a stick, *not your hands*, to remove an obstruction from the discharge chute.
- Stay behind the handles and away from the discharge opening while operating the snowthrower.
- Keep face, hands, feet, and any other part of your body or clothing away from concealed, moving, or rotating parts.

You can rotate the discharge chute 180° side to side by turning the crank handle (Fig. 36).

You can move the chute deflector, on top of the discharge chute, up and down to control the height and distance the snowthrower thrower snow (Fig. 36).

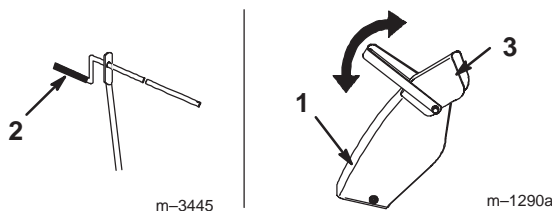

Figure 36

1. Discharge chute
2. Crank handle
3. Chute deflector

Tips for Throwing Snow



- Remove snow as soon as possible after it falls. This produces best snow removal results.
 - Adjust the skids to match the type of surface being cleaned; refer to Adjusting the Skids, page 21.
 - The snowthrower is designed to clean snow down to the contact surface, but there are times when the front of the snowthrower may tend to ride up. If this happens, reduce forward speed.
 - Discharge snow downwind whenever possible, and overlap each pass to ensure complete snow removal.
 - If the wheels slip, shift the high-low range lever to low (L) to reduce forward speed.
 - Run the snowthrower for a few minutes after clearing snow so moving parts do not freeze. Engage the PTO to clear any remaining snow from the inside housing.
 - Do not overload the snowthrower by clearing snow at too fast a rate. If the engine slows down, reduce forward speed.
 - Always use full throttle (maximum engine speed) when throwing snow.
 - In wet or slushy conditions, reduce clogging of the discharge chute by maintaining maximum engine speed and by not overloading the engine.
 - In some snow and cold weather conditions, some controls and moving parts may freeze. Therefore, when any control becomes hard to operate, stop the machine and wait for all moving parts to stop; then check all parts for freeze up. Free all controls and moving parts before operating.
- Important** Do not use excessive force when trying to free frozen controls.
- Use low range (L) on the high-low range lever for best performance and smoothest operation.

Maintenance

Note: Determine the left and right side of the machine from the normal operating position.

Recommended Maintenance Schedule

Maintenance Service Interval	Maintenance Procedure
25 hours	<ul style="list-style-type: none"> • Drive shaft bearings—grease • Drive chain—oil • Gear box lubricant—check • Drive chain—adjust tension
Fall Service	<ul style="list-style-type: none"> • Drive shaft bearings—grease • Drive chain—oil • Gear box lubricant—add • Drive chain—adjust tension • Belt—check for wear/cracks • Scraper—check for wear
Storage Service	<ul style="list-style-type: none"> • Drive shaft bearings—grease • Drive chain—oil • Gear box lubricant—add • Drive chain—adjust tension • Belt—check for wear/cracks • Scraper—check for wear • Chipped Surfaces—paint

Caution

If you leave the key in the ignition switch, someone could accidentally start the engine and seriously injure you or other bystanders.

Remove the key from the ignition and disconnect the wire from the spark plug before you do any maintenance. Set the wire aside so that it does not accidentally contact the spark plug.

Greasing and Lubrication

Grease and oil the machine after every 25 operating hours or once a year, whichever occurs first.

Grease Type: General-purpose grease.

Oil Type: SAE 10W or 10W30.

Greasing the Bearings

Figures 37 and 38 illustrate the fittings that you need to grease.

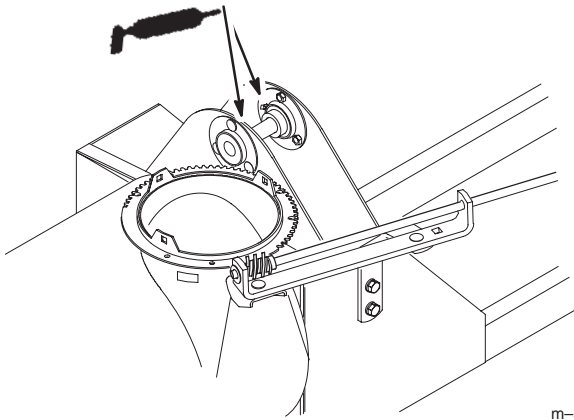
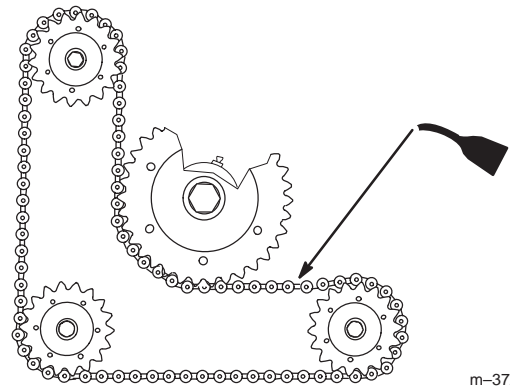

Figure 37

m-3737



m-3723

Figure 39

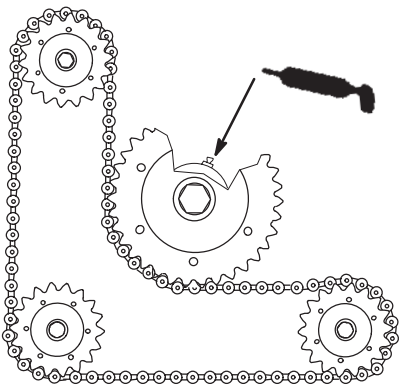

m-3723

Figure 38

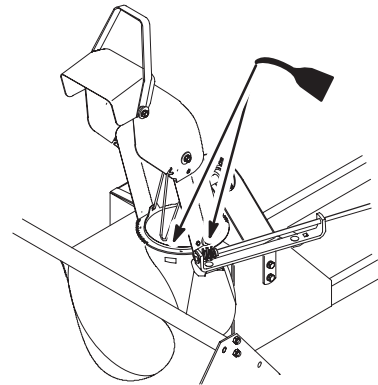

m-3732

Figure 40

1. Disengage the PTO, set the parking brake, lower the attachment lift, stop the engine, and remove the key.
2. Clean the grease fittings with a rag.
3. Scrape any paint off the front of the fittings.
4. Connect a grease gun to each fitting in turn and pump grease into them.
5. Wipe up any excess grease.

Oiling the Drive Chain and Discharge Chute

1. Disengage the PTO, set the parking brake, lower the attachment lift, stop the engine, and remove the key.
2. Coat the entire chain with oil and allow it to penetrate each roller (Fig. 39).

3. Place a few drops of oil on the discharge chute rotator shaft and discharge chute mounting (Fig. 40).

4. Wipe off excess oil.

Adding Gear Box Lubricant

1. Move the snowthrower to a level surface.
2. Disengage the PTO, set the parking brake, lower the attachment lift, stop the engine, and remove the key.
3. Clean area around plug with a rag and remove plug (Fig. 41).

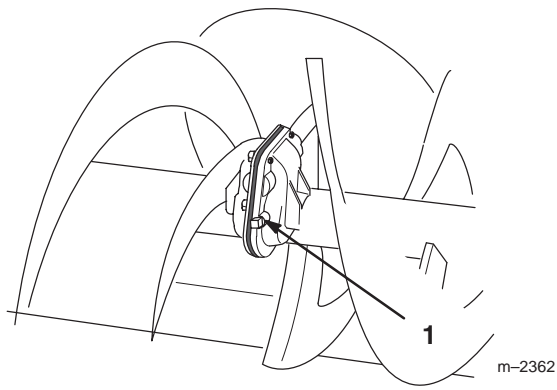

Figure 41

1. Plug

4. Add SAE 90 gear oil until it is level with the bottom of the hole in the housing (Fig. 41).

5. Apply pipe sealant to the plug and install it.

Replacing the Snowthrower Belt

Once each year, examine the drive belt for signs of wear and cracking. If any are found, purchase a belt from an Authorized Service Dealer and replace it.

Note: The procedure below documents how to replace the belt when the snowthrower is on the tractor, so you can replace the belt in the case that it breaks. You can also easily replace the belt prior to installing the snowthrower on the tractor.

Removing Belt

1. Move the snowthrower to a level surface.
2. Disengage the PTO, set the parking brake, lower the attachment lift, stop the engine, and remove the key.
3. Relieve the snowthrower belt tension by pulling the spring tension lever forward until you have enough slack to disconnect the link from the keyhole slot (Fig. 20).

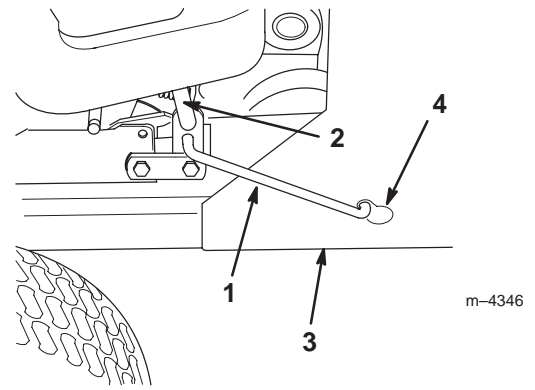

Figure 42

Right side of tractor shown

1. Spring tension link
2. Spring tension lever
3. Snowthrower frame
4. Keyhole slot

4. Remove the pulley cover from the snowthrower frame assembly, by removing the four #10 x 1/2 in. (13 mm) screws (Fig. 8).

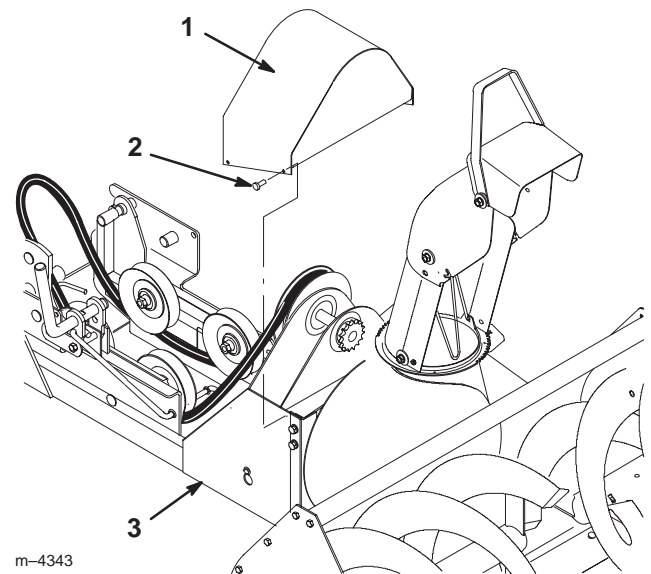

Figure 43

1. Pulley cover
2. Screw #10 x 1/2" (13 mm)
3. Snowthrower frame assembly

5. Lift up on the spring-loaded pulley and remove the snowthrower belt from the snowthrower pulley (Fig. 18).

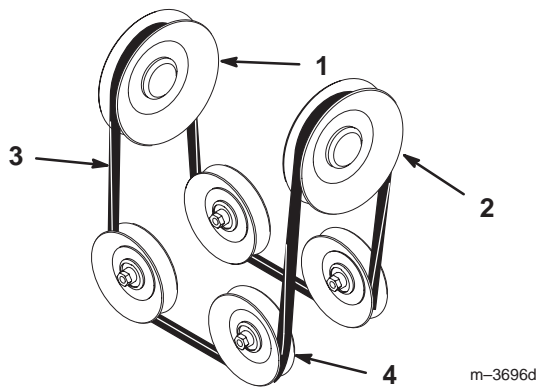

Figure 44

- | | |
|-----------------------|-------------------------|
| 1. Engine PTO pulley | 3. Belt |
| 2. Snowthrower pulley | 4. Spring-loaded pulley |

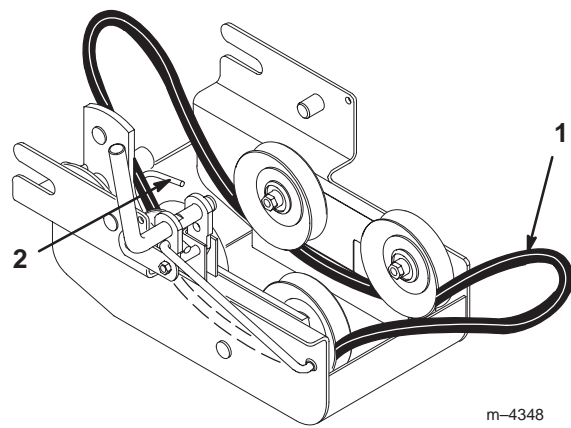

Figure 45

- | | |
|---------------------|---------------|
| 1. Snowthrower belt | 2. Belt guide |
|---------------------|---------------|

6. Open the hood of the tractor.
7. Remove the right-hand side panel.

⚠
Caution
⚠

Components under the hood will be hot if the tractor has been running. If you touch hot components you may be burned.

Allow the tractor to cool before performing maintenance or touching components under the hood.

8. Remove the snowthrower belt from around the engine PTO pulley (Fig. 18).

Installing Belt

1. Route the new snowthrower belt under the pulleys and inside the belt guide (Fig. 45).

2. Route the snowthrower belt around the engine PTO pulley.
3. Replace the right side panel and close the hood.
4. Lift up on the spring-loaded pulley and route the snowthrower belt around the snowthrower pulley.
5. Ensure that the wide side of the PTO drive belt is toward the outside diameter of all six of the pulleys (Fig. 7).

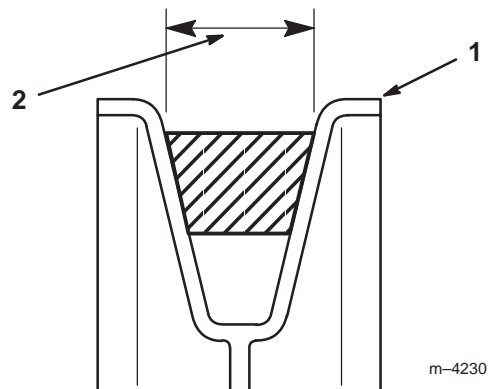

Figure 46

- | | |
|----------------------------|----------------------|
| 1. Pulley outside diameter | 2. Wide side of belt |
|----------------------------|----------------------|

6. On the right side of the tractor, pull forward on the spring tension lever and connect the spring tension link on the pulley housing to the keyhole slot in the snowthrower frame (Fig. 20).
7. Attach the pulley cover to the snowthrower frame assembly with four # 10 x 1/2 in. (13 mm) screws (Fig. 8)

Adjusting the Skids

The distance between the scraper blade and the ground is controlled by skids on each side of the housing. The height can be adjusted so the scraper blade will not catch on uneven surfaces

1. Move the snowthrower to a level surface.
2. Disengage the PTO and set the parking brake.
3. Raise the attachment lift enough for the skids to clear the ground.
4. Support the snowthrower housing off the ground.
5. Stop the engine and remove the ignition key.
6. Loosen the nuts securing the skids to the housing until the skids slide up and down easily (Fig. 47).

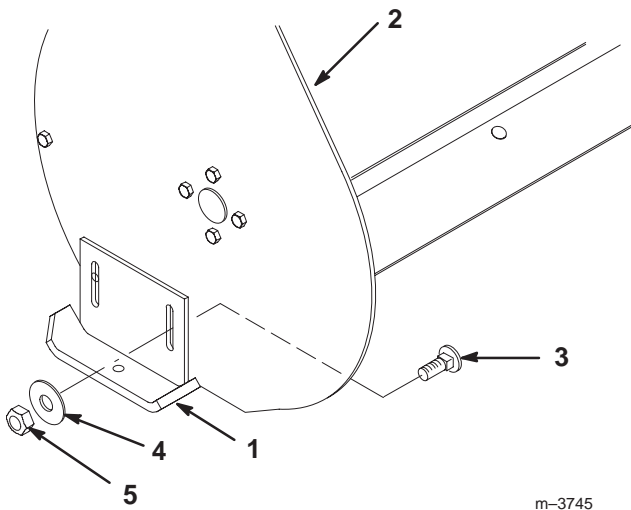

Figure 47

- | | |
|-----------------------------|----------------|
| 1. Skid | 4. Flat washer |
| 2. Housing | 5. 5/16" nut |
| 3. Carriage bolt, 5/16" x 1 | |

7. Raise or lower the skids equally on both sides to obtain level scraping action, and tighten nuts securely (Fig. 47).

Note: On smooth, paved surfaces, the scraper blade can be close to the surface. On uneven, gravel or crushed rock surfaces, adjust the skids to raise the scraper, thereby preventing catching or picking up rocks.

Important The scraper should be higher above the pavement if the pavement surfaces on which the snowthrower will be used are cracked, rough or uneven.

Replacing the Scraper Blade

The scraper blade contacts the ground preventing damage to the snowthrower housing. Periodically inspect the scraper blade for wear. When the scraper becomes worn, before the working surface contacts the housing, replace the scraper blade.

1. Disengage the PTO, set the parking brake, lower the attachment lift, stop the engine, and remove the key.
2. Support the snowthrower housing off the ground.
3. Remove the nuts, washers, carriage bolts, and scraper blade (Fig. 48).
4. Install a new scraper blade with the previously removed hardware (Fig. 48).

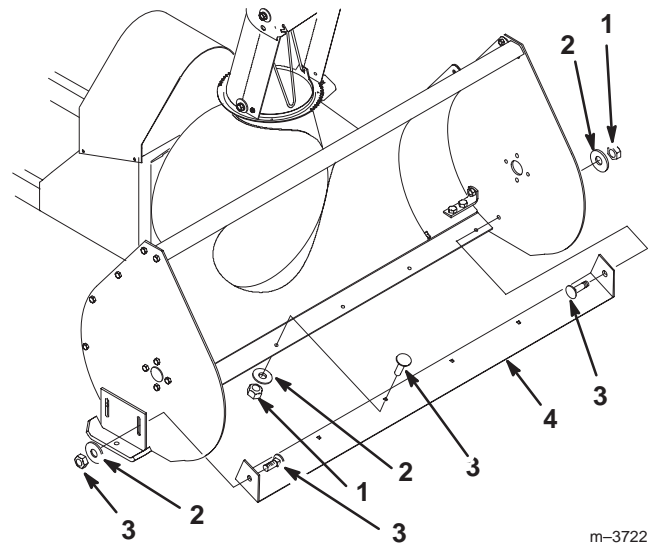

Figure 48

- | | |
|-----------|------------------|
| 1. Nut | 3. Carriage bolt |
| 2. Washer | 4. Scraper blade |

Adjusting the Drive Chain Tension

Check the drive chain tension after every 25 operating hours or once a year, whichever occurs first. It should have 1/8 to 1/2 in. deflection in the area indicated in Figure 49. If it does not meet this specification, use the following procedure to adjust it.

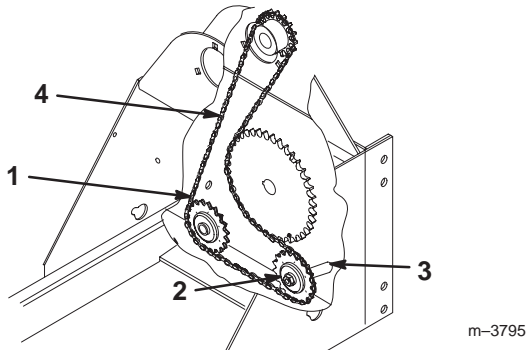

Figure 49

- | | |
|-------------------|--------------------------|
| 1. Drive chain | 3. Adjustment slot |
| 2. Idler sprocket | 4. Check deflection here |

1. Disengage the PTO, set the parking brake, lower the attachment lift, stop the engine, and remove the key.
2. Loosen the nut that secures the idler sprocket. (Fig. 49).
3. Slide the idler sprocket in the adjustment slot until the chain is snug, but not tight.
4. Torque the nut securing the sprocket to 67 to 83 ft-lbs (90.8 to 112.5 N·m).

Important Do not overtighten the chain or excessive wear will occur.

Storage

1. Before long-term storage, wash the machine with mild detergent and water to remove dirt and grime from the entire machine.
2. Check the condition of the scraper blade; refer to Replacing the Scraper Blade, page 21.
3. Check the condition of the drive belt and chain.
4. Grease and oil the snowthrower; refer to Greasing and Lubrication, page 17.
5. Check and tighten all bolts, nuts, and screws. Repair or replace any part that is damaged or defective.
6. Paint all scratched or bare metal surfaces. Paint is available from your Authorized Service Dealer.
7. Coat the inside auger housing and discharge chute with automotive wax to prevent rust and reduce the sticking of snow to these surfaces.
8. Store the machine in a clean, dry garage or storage area. Cover the machine to protect it and keep it clean.

