



Wheel Horse®  
**44'' Snowthrower**  
for  
**5xi Lawn and Garden Tractors**  
Model No. 79366 – 8900501 & Up

---

# Operator's Manual

**IMPORTANT:** Read this manual, and **your tractor manual**, carefully. They contain information about your safety and the safety of others. Also become familiar with the controls and their proper use before you operate the product.

# Introduction

We want you to be completely satisfied with your new product, so feel free to contact your local Authorized Service Dealer for help with service, genuine replacement parts, or other information you may require.

Whenever you contact your Authorized Service Dealer or the factory, always know the model and serial numbers of your product. These numbers will help the Service Dealer or Service Representative provide exact information about your specific product. You will find the model and serial number plate located in a unique place on the product as shown below.

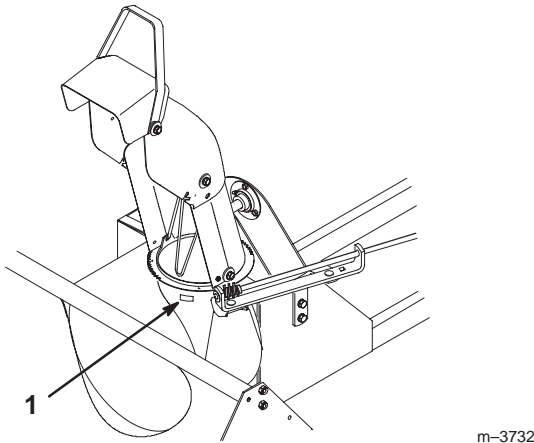

Figure 1

1. Model and Serial Number Plate

For your convenience, write the product model and serial numbers in the space below.

<b>Model No.</b> _____
<b>Serial No.</b> _____

The warning system in this manual identifies potential hazards and has special safety messages that help you and others avoid personal injury, even death. DANGER, WARNING and CAUTION are signal words used to identify the level of hazard. However, regardless of the hazard, be extremely careful.

**DANGER** signals an extreme hazard that will cause serious injury or death if the recommended precautions are not followed.

**WARNING** signals a hazard that may cause serious injury or death if the recommended precautions are not followed.

**CAUTION** signals a hazard that may cause minor or moderate injury if the recommended precautions are not followed.

Two other words are also used to highlight information. “Important” calls attention to special mechanical information and “Note” emphasizes general information worthy of special attention.

The left and right side of the machine is determined by sitting on the seat in the normal operator’s position.

# Contents

	<b>Page</b>		<b>Page</b>
Safety and Instruction Decals .....	2	Adjusting The Discharge Chute .....	16
Installation .....	3	Tips for Throwing Snow .....	16
Loose Parts .....	3	Maintenance .....	17
Assembling the Snowthrower .....	5	Service Interval Chart .....	17
Setting Up the Tractor .....	6	Greasing and Lubrication .....	17
Installing the Snowthrower on the Tractor ..	6	Replacing the Snowthrower Belt .....	19
Removing the Snowthrower .....	11	Adjusting the Skids .....	20
Operation .....	14	Replacing the Scraper Blade .....	21
Operating the Power Take Off (PTO) ....	14	Adjusting Drive Chain Tension .....	21
Operating the Attachment Lift Lever .....	15	Storage .....	22

## Safety and Instruction Decals



Safety decals and instructions are easily visible to the operator and are located near any area of potential danger. Replace any decal that is damaged or lost.

**ON UPPER DISCHARGE CHUTE**  
**CHUTE**  
**(Part No. 94-8079)**



**ON TOP OF HOUSING**  
**(Part No. 92-8652)**



**(2) ON TOP OF HOUSING**  
**(Part No. 63-2380)**



**ON TOP OF PULLEY COVER**  
**(Part No. 98-8705)**



# Installation

## Loose Parts

**Note:** A rear-mount Attach-A-Matic™ and rear wheel weights and chains, all of which must be purchased separately, are required to operate the tractor equipped with this snowthrower. Use the chart below to identify parts used for assembly.

DESCRIPTION	QTY.	USE
Snowthrower frame assembly	1	Attach lift tube
Lift tube	1	
Clevis pin 1/2" x 2" (51 mm)	1	
Clevis clip	1	
Discharge chute assembly	1	Assemble discharge chute
Washer 5/16" (8 mm)	3	
Locknut 5/16"	3	
Carriage bolt 5/16-18 x 3/4" (19 mm)	3	
Clevis pin 3/8" x 1" (25 mm)	2	Prepare tractor attachment lift
Hairpin cotter—small	2	
Pulley box	1	Install pulley box
Belt	1	

DESCRIPTION	QTY.	USE
Clevis pin 1/2" x 1" (25 mm)	1	Mount snowthrower to tractor
Clevis clip	1	
Spring tension link	1	
Support rod link	1	
Support brace	2	
Washer 13/16" (21 mm)	2	
Hairpin cotter—large	4	
Washer 15/16" (24 mm)	2	
Crank support	1	
Locking pin	1	
Chute control rod	1	
Hairpin cotter—small	1	
Pulley cover	1	
Screw #10 x 1/2" (13 mm)	4	
Rod Assembly	1	
Spacer washer 1" (25 mm)	2	
Clevis pin 5/16" x 1-3/8" (35 mm)	2	
Hairpin cotter	2	
Flat washer 5/16" (8 mm)	2	
Operator's Manual	1	Read before operating

# Assembling the Snowthrower

## Attach Lift Tube

Connect the lift tube to the snowthrower frame assembly with the 2" (51 mm) clevis pin and clip (Fig. 2)

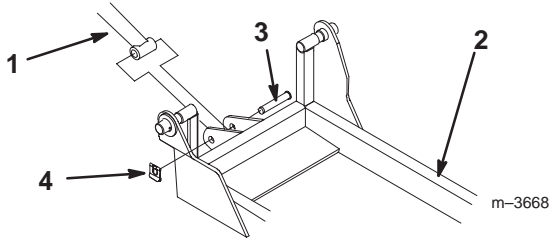

Figure 2

- |                               |                          |
|-------------------------------|--------------------------|
| 1. Lift tube                  | 3. Clevis pin 2" (51 mm) |
| 2. Snowthrower frame assembly | 4. Clevis clip           |

## Verify the Drive Chain Tension

Verify that the drive chain has between 1/8" and 1/2" deflection in the area shown in Figure 4. If the chain is too tight or too loose, adjust it; refer to Adjusting Drive Chain Tension, page 21.

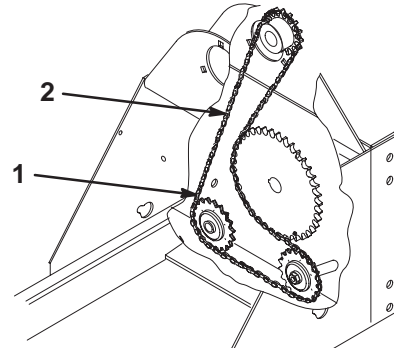

Figure 4

- |                |                         |
|----------------|-------------------------|
| 1. Drive chain | 2. Test deflection here |
|----------------|-------------------------|

## Assemble the Discharge Chute

Install the discharge chute assembly onto the chute ring with (3) 5/16 x 3/4" (19 mm) carriage bolts (heads to the inside), (3) 5/16" (8 mm) washers and (3) 5/16" locknuts (Fig. 3).

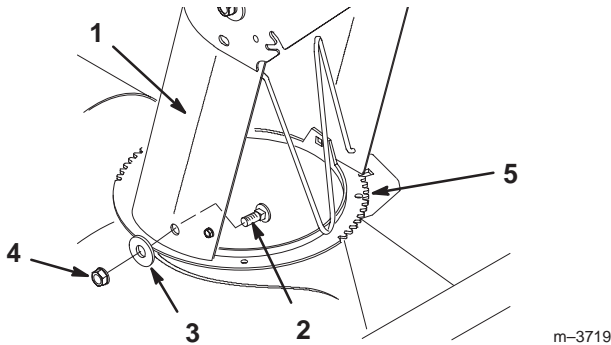

Figure 3

- |                                      |                        |
|--------------------------------------|------------------------|
| 1. Discharge chute assembly          | 3. Washer 5/16" (8 mm) |
| 2. Carriage bolt 5/16 x 3/4" (19 mm) | 4. Locknut 5/16"       |
|                                      | 5. Chute ring          |

## Install Drive Belt and Pulley Cover

1. Ensure that the belt is under the pulleys and inside the belt guide in the pulley box (Fig. 5).
2. Slide the pulley box into the snowthrower frame (Fig. 5).
3. Route the belt over the snowthrower pulley (Fig. 5).

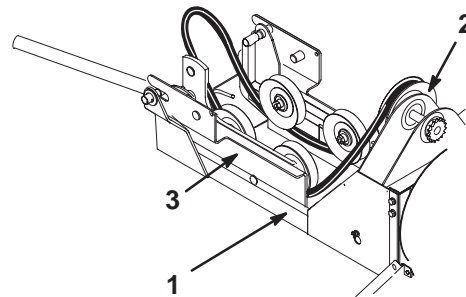
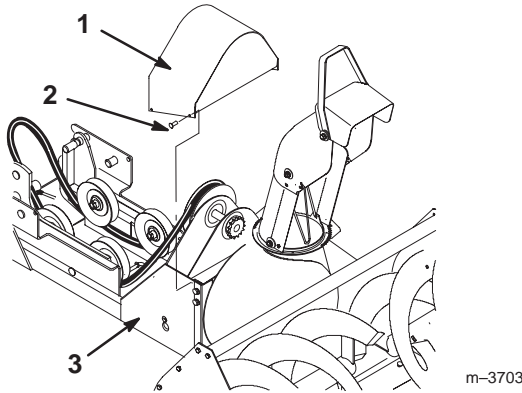

Figure 5

- |                       |               |
|-----------------------|---------------|
| 1. Snowthrower frame  | 3. Pulley box |
| 2. Snowthrower pulley |               |

4. Attach the pulley cover to the snowthrower frame assembly with (4) #10 x 1/2" (13 mm) screws (Fig. 6).



**Figure 6**

- 1. Pulley cover
- 2. Screw #10 x 1/2" (13 mm)
- 3. Snowthrower frame assembly

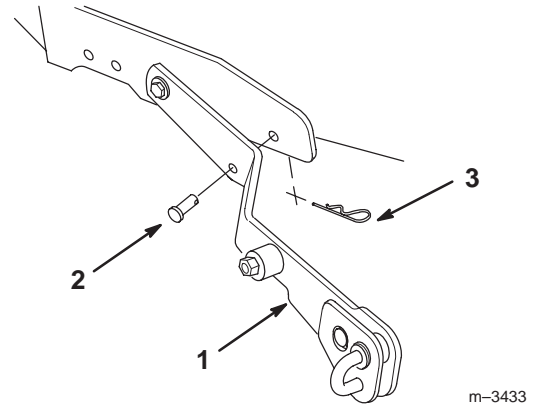

**Figure 7**

- 1. Lift arm
- 2. Clevis pin 3/8" x 1" (25 mm)
- 3. Hairpin cotter—small

## Setting Up the Tractor

### Install Rear Wheel Weights and Chains

Install the rear wheel weights and chains. Refer to Attachment Operator's Manual for instructions.

### Install the Rear Attach-A-Matic™

Install the rear Attach-A-Matic™ to the tractor; refer to the installation instructions that come with the rear Attach-A-Matic™ mount.

### Prepare the Tractor's Attachment Lift

1. Start the engine
2. Raise the attachment lift.
3. Set the parking brake and turn the ignition key to "STOP" to stop the engine. Remove the key.
4. The two lift arms are attached to the tractor frame, just ahead of the rear wheels. Secure the lift arms to the tractor frame with 3/8" x 1" (25 mm) clevis pins and small hairpin cotters (Fig. 7).

These pins must be installed when operating with a blade, snowthrower, or the tiller attachment.

**Note:** Remove the pins to attach a mower.

## Installing the Snowthrower on the Tractor

1. Position the snowthrower frame assembly and its attachment parts on a level surface with enough space behind them to accommodate the tractor.
2. Park the tractor over the snowthrower lift rod between the tractor wheels (Fig. 8). Lower the attachment lift and turn the ignition key to "STOP" to stop the engine. Remove the key.

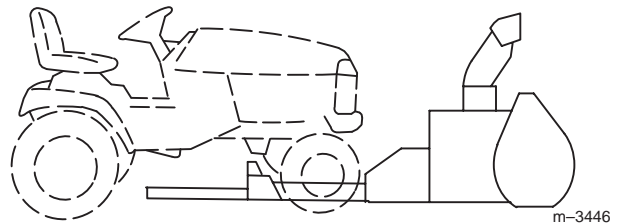

**Figure 8**

3. With the High–Low range selector in neutral “N,” pull the tractor forward toward the snowthrower until the end of the snowthrower frame is just underneath the tractor’s front Attach-A-Matic™.
4. Ensure the latches on the tractor’s front Attach-A-Matic™ are open. Then slide the pulley box completely into the Attach-A-Matic™ latches. Close the latches by rotating them down (Fig. 9).

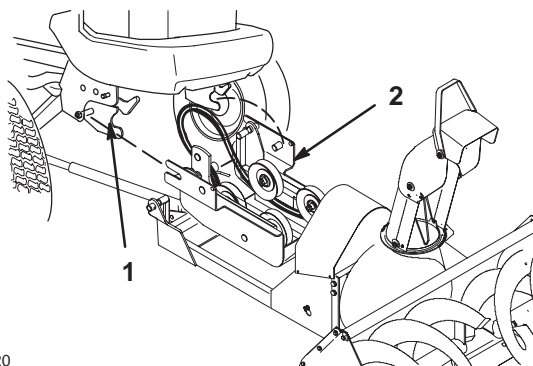

m-3720

**Figure 9**

1. Attach-A-Matic™ latches
2. Pulley box

5. Install (2) 1–3/8” (35 mm) long clevis pins into the locking holes of the pulley box. Secure them with (2) 5/16” (8 mm) flat washers and (2) hairpin cotters on the inside (Fig. 10).

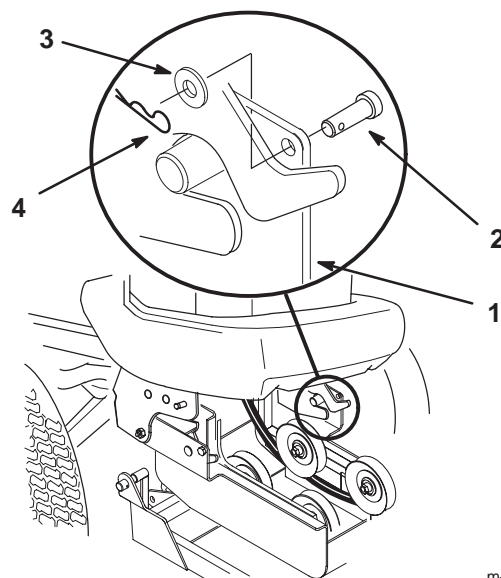

m-3738

**Figure 10**

1. Pulley box
2. Clevis pin 1–3/8” (35 mm)
3. Flat washer 5/16” (8 mm)
4. Hairpin cotter

6. Now connect the snowthrower frame to the mid Attach-A-Matic™. You will need the crank support to help with this.

- A. Continue pulling the tractor toward the snowthrower until the end of the snowthrower frame is directly below the mid Attach-A-Matic™ hitch (Fig. 8).
- B. Make sure the mid Attach-A-Matic™ latches are open.
- C. Slide the round end of the crank support under the notch in the snowthrower frame (Fig. 11).

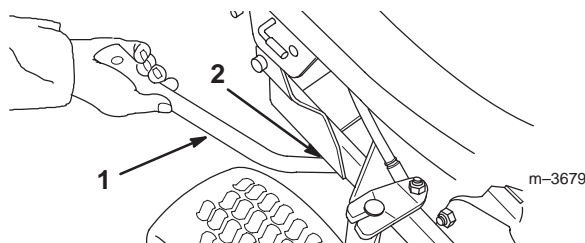

m-3679

**Figure 11**

1. Crank Support
2. Notch in snowthrower frame

- D. Use the crank support as a lever to lift the snowthrower frame until its connecting pins are completely inside the notches in the mid Attach-A-Matic™ (Fig. 12).

**CAUTION**

**POTENTIAL HAZARD**

- The snowthrower frame assembly is heavy.

**WHAT CAN HAPPEN**

- Hands and feet can be injured by the weight of the snowthrower coming down on them.

**HOW TO AVOID THE HAZARD**

- Keep hands and feet away from the underside of the snowthrower frame.

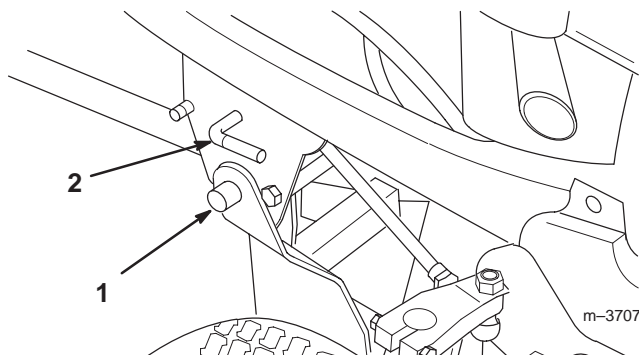

**Figure 12**

1. Snowthrower frame connecting pins      2. Mid Attach-A-Matic™ lever

- E. Turn the mid Attach-A-Matic™ lever counterclockwise to lock the snowthrower in place (Fig. 12).

**IMPORTANT: Make sure the snowthrower frame is locked in place. You should hear a distinct click if the snowthrower is correctly mounted.**

- F. Set the parking brake.

7. Add (2) 1" (25 mm) washers onto the end of the rod assembly, then slide it into the lift tube.

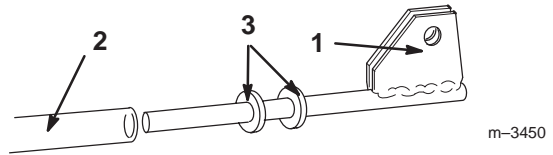
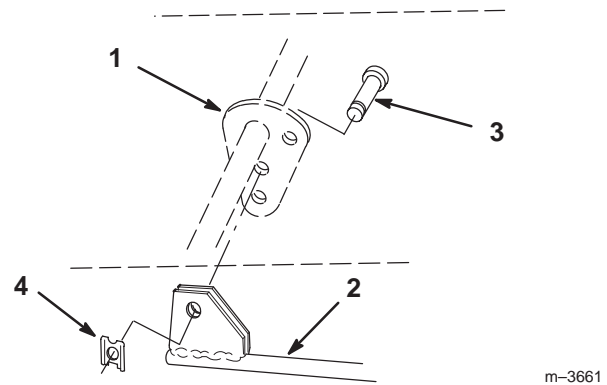

**Figure 13**

1. Rod assembly      3. Washer 1" (25 mm)  
2. Lift tube

**Note:** A washer may need to be removed from the rod assembly for the holes to line up with the attachment lift plate.

8. From beneath the tractor, connect the snowthrower rod assembly to the middle hole in the attachment lift plate with the 1" (25 mm) clevis pin and clip (Fig. 14).



**Figure 14**

Right side of tractor shown

1. Attachment lift plate      3. Clevis pin 1/2" x 1" (25 mm)  
2. Snowthrower rod assembly      4. Clevis clip

9. Now install the snowthrower belt to the engine PTO pulley:
  - A. Open the hood of the tractor
  - B. Remove the right-hand side panel.

**CAUTION**

**POTENTIAL HAZARD**

- Components under the hood will be hot if the tractor has been running.

**WHAT CAN HAPPEN**

- Touching hot components can cause burns.

**HOW TO AVOID THE HAZARD**

- Allow the tractor to cool before performing maintenance or touching components under the hood.

- C. Route the snowthrower belt around the engine PTO pulley (Fig. 15).

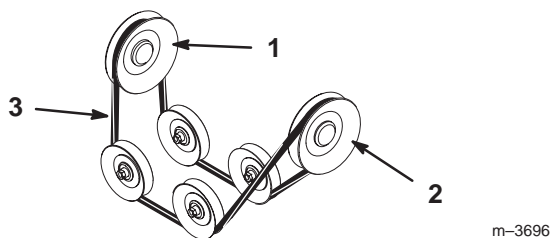
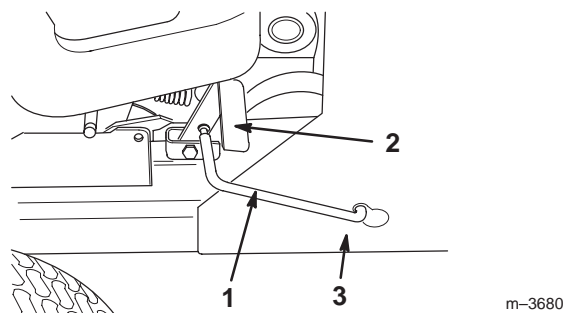

**Figure 15**

1. Engine PTO pulley
2. Snowthrower pulley
3. Belt

- D. Replace the right side panel and close the hood.

10. On the right side of the tractor, pull forward on the spring tension link lever and connect the spring tension link from the spring tension link lever on the pulley housing to the snowthrower frame (Fig. 16).



**Figure 16**

1. Spring tension link
2. Spring tension link lever
3. Snowthrower frame

11. Open the latches on the rear Attach-A-Matic™. Put the support rod link into the front notches on the rear Attach-A-Matic™ and close the latches to secure it in place (Fig. 17).
12. Slide the non adjusting ends of the two support braces onto the support rod link that is now in the rear Attach-A-Matic™ mount.
  - Make sure the rod of each brace faces outward.
  - Secure the braces to the rod with a 13/16" (21 mm) washer and a large hairpin cotter (Fig. 17).

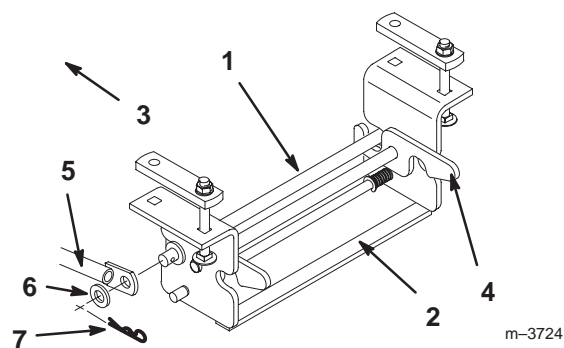

**Figure 17**

1. Support rod link
2. Rear Attach-A-Matic™
3. Front of tractor
4. Rear Attach-A-Matic™ latch
5. Support brace
6. Washer 13/16" (21 mm)
7. Hairpin cotter—large

13. Secure the other ends of the support braces to the frame rods protruding from the mid Attach-A-Matic™ with a 15/16" (24 mm) washer and a large hairpin cotter (Fig. 18). You may need to turn the adjuster of each brace before the holes in the adjuster align with the frame rod.

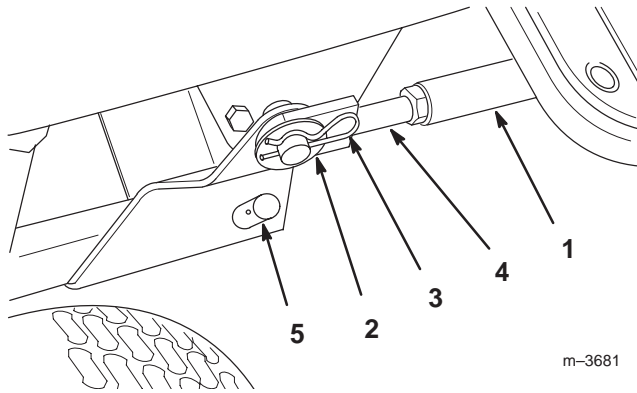
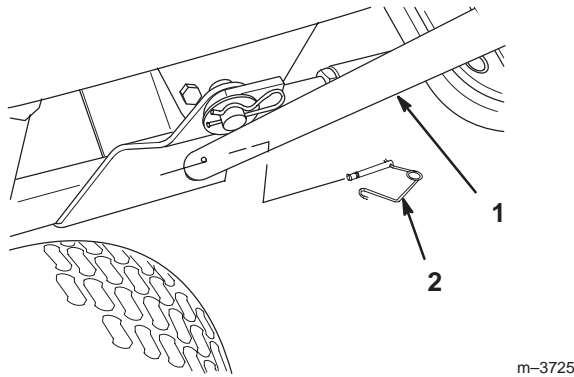

**Figure 18**

Left side of tractor shown

- |                   |                                    |
|-------------------|------------------------------------|
| 1. Support brace  | 4. Adjuster                        |
| 2. Flat washer    | 5. Mounting post for crank support |
| 3. Hairpin cotter |                                    |

14. Slide the crank support onto the mounting post on the left-hand side of the tractor (Fig. 18). Secure it in position with the locking pin (Fig. 19).



**Figure 19**

- |                  |                |
|------------------|----------------|
| 1. Crank support | 2. Locking pin |
|------------------|----------------|

15. Slide the chute control rod through the hole in the end of the crank support and connect the end of the chute control rod to the universal joint on the snowthrower with a hairpin cotter (Fig. 20).

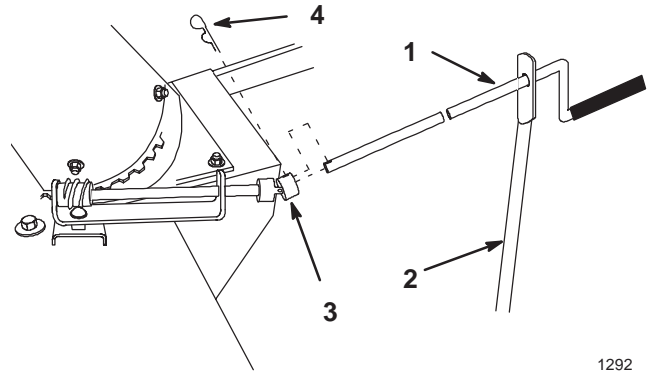
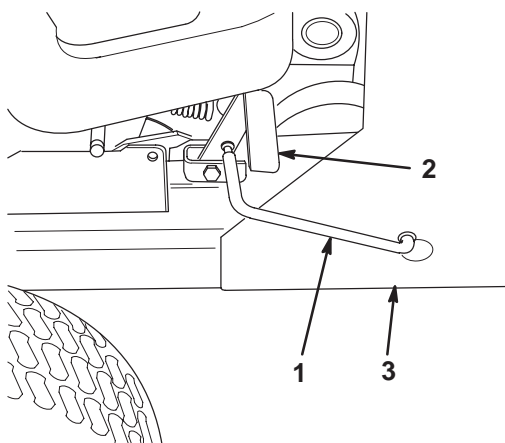

**Figure 20**

- |                      |                         |
|----------------------|-------------------------|
| 1. Chute control rod | 3. Universal joint      |
| 2. Crank support     | 4. Hairpin cotter—small |

## Removing the Snowthrower

1. Park the tractor on a level surface, lower the attachment lift, disengage the power take off (PTO), set the parking brake and turn the ignition key to "STOP" to stop the engine. Remove the key.
2. Disconnect the pulley housing from the snowthrower frame by pulling the spring tension link lever forward until you have enough slack to disconnect the link (Fig. 21).



m-3680

**Figure 21**

- |                              |                      |
|------------------------------|----------------------|
| 1. Spring tension link       | 3. Snowthrower frame |
| 2. Spring tension link lever |                      |

3. Remove the snowthrower belt from the engine PTO pulley:
  - A. Open the hood of the tractor
  - B. Remove the right-hand side panel.

### CAUTION

#### POTENTIAL HAZARD

- Components under the hood will be hot if the tractor has been running.

#### WHAT CAN HAPPEN

- Touching hot components can cause burns.

#### HOW TO AVOID THE HAZARD

- Allow the tractor to cool before performing maintenance or touching components under the hood.

- C. Remove the snowthrower belt from around the engine PTO pulley (Fig. 22).

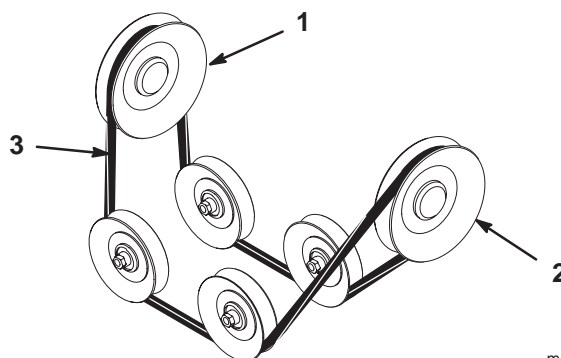

m-3696

**Figure 22**

- |                       |         |
|-----------------------|---------|
| 1. Engine PTO pulley  | 3. Belt |
| 2. Snowthrower pulley |         |

- D. Replace the right side panel and close the hood.

- Remove the chute control rod by removing the hairpin cotter connecting it to the universal joint (Fig. 23). Slide the chute control rod out of the end of the crank support.

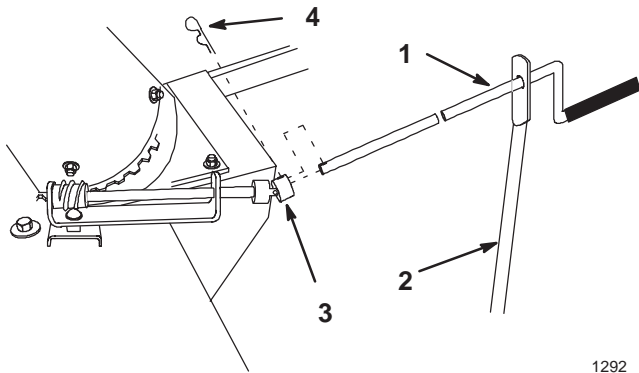

Figure 23

- |                      |                    |
|----------------------|--------------------|
| 1. Chute control rod | 3. Universal joint |
| 2. Crank support     | 4. Hairpin cotter  |

- Remove the crank support by removing the locking pin at its base (Fig. 24), then lifting the support from its mounting post.
- Remove the support braces from the frame rods protruding from the mid Attach-A-Matic™ by removing the hairpin cotters and washers (Fig. 24).

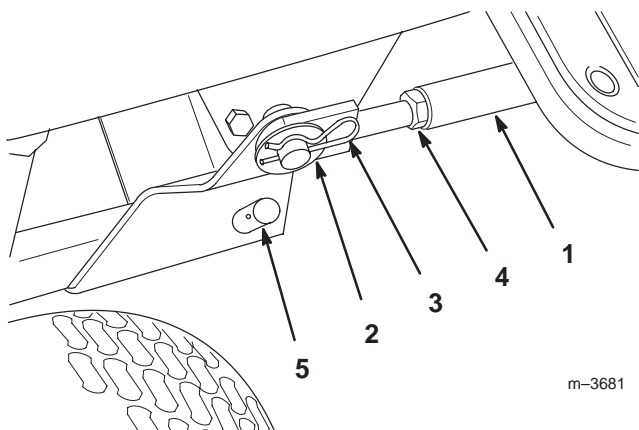

Figure 24

Left side of tractor shown

- |                   |                                    |
|-------------------|------------------------------------|
| 1. Support brace  | 4. Adjustment nut for brace        |
| 2. Flat washer    | 5. Mounting post for crank support |
| 3. Hairpin cotter |                                    |

- Remove the other ends of the two support braces from the rear Attach-A-Matic™ mount by removing the hairpin cotters and washers (Fig. 25).
- Release the latches on the rear Attach-A-Matic™ and remove the support rod link (Fig. 25).

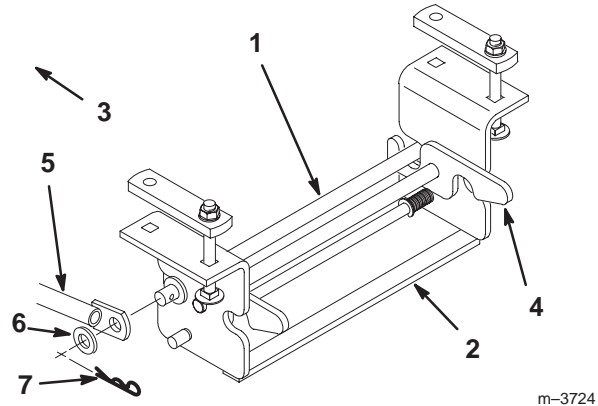

Figure 25

- |                               |                          |
|-------------------------------|--------------------------|
| 1. Support rod link           | 5. Support brace         |
| 2. Rear Attach-A-Matic™       | 6. Washer 13/16" (21 mm) |
| 3. Front of tractor           | 7. Hairpin cotter-large  |
| 4. Rear Attach-A-Matic™ latch |                          |

- Disconnect the snowthrower lift rod from the attachment lift plate by removing the clip from the clevis pin (Fig. 26).

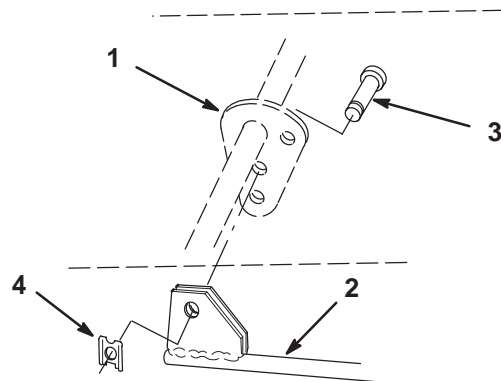



Figure 26

Right side of tractor shown

- |                          |                                 |
|--------------------------|---------------------------------|
| 1. Attachment lift plate | 3. Clevis pin 1/2" x 1" (25 mm) |
| 2. Snowthrower lift rod  | 4. Clevis clip                  |

10. Please use **CAUTION** during this step!

**WARNING**

**POTENTIAL HAZARD**

- The snowthrower frame assembly is heavy.

**WHAT CAN HAPPEN**

- Hands and feet can be injured by the weight of the snowthrower coming down on them.

**HOW TO AVOID THE HAZARD**

- Keep hands and feet away from the underside of the snowthrower frame.

Press the button of the mid Attach-A-Matic™ and carefully turn the lever clockwise to release the snowthrower (Fig. 27).

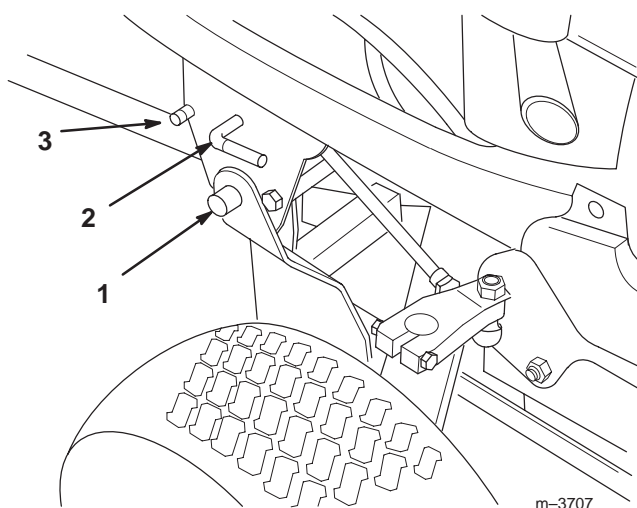
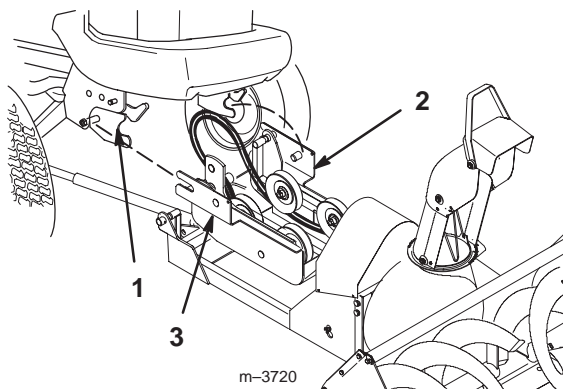

**Figure 27**

- |                                     |                               |
|-------------------------------------|-------------------------------|
| 1. Snowthrower frame connecting pin | 3. Mid Attach-A-Matic™ button |
| 2. Mid Attach-A-Matic™ lever        |                               |

11. Put the tractor's High–Low range lever in neutral "N" and release the parking brake.
12. Push the tractor back, away from the snowthrower until there is sufficient space to remove the pulley box.

13. Remove the clevis pins from the pulley box locking holes (Fig. 28). Open the latches of the front Attach-A-Matic™, remove the pulley box, and slide it into snowthrower frame.
14. Install the clevis pins into the locking holes of the pulley box for storage.



**Figure 28**

- |                            |                  |
|----------------------------|------------------|
| 1. Attach-A-Matic™ latches | 3. Locking holes |
| 2. Pulley box              |                  |

15. Push the tractor back, away from the snowthrower frame. Set the parking brake.

# Operation

## DANGER

### POTENTIAL HAZARD

- When the snowthrower is attached to the tractor, without additional weight, the tractor may become unstable.

### WHAT CAN HAPPEN

- Loss of traction and stability may cause loss of tractor control.

### HOW TO AVOID THE HAZARD

- NEVER operate the tractor equipped with the snowthrower, unless rear weights are installed.

## DANGER

### POTENTIAL HAZARD

- Rotating auger can cut off fingers, hands or other body parts and throw objects.

### WHAT CAN HAPPEN

- Contact with rotating auger and thrown debris can cause severe injury or death.

### HOW TO AVOID THE HAZARD

- Stay away from the discharge and auger openings while operating the snowthrower.
- Keep your hands, feet, and any other part of your body or clothing away from concealed, moving or rotating parts.
- Use a stick, not your hand, to remove obstructions from the discharge chute or auger housing.
- Before adjusting, cleaning, repairing and inspecting the snowthrower and before unlogging the discharge chute, shut off the engine and wait for all moving parts to stop. Move the power take off (PTO) to “OFF” and rotate the ignition key to “OFF.” Remove the key.

## Operating the Power Take Off (PTO)

The power take-off (PTO) switch engages and disengages power to the electric clutch.

If the ignition key is in the RUN or LIGHTS position and the power take off (PTO) is engaged, the PTO indicator light will be on. When this light is on, it is a reminder: the implement is being powered and the starter will not crank while the PTO is engaged. Always turn off the PTO before getting off the seat.

## Engaging the Power Take Off (PTO)

1. Depress the brake pedal to stop the machine.
2. Move the throttle lever to FAST.

**IMPORTANT:** For best performance, always use full throttle when the power take off (PTO) switch is ON.

3. Pull the power take off (PTO) switch to ON (Fig. 29).

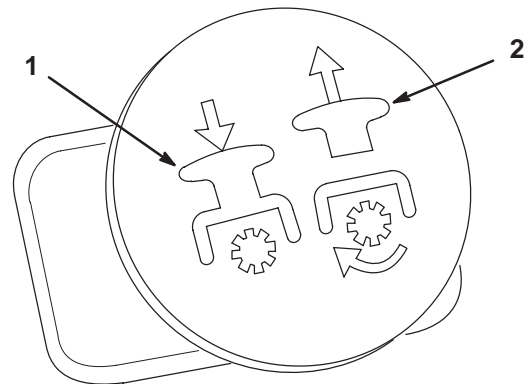

m-3264

Figure 29

1. Push (off-disengaged)
2. Pull (on-engaged)

## Disengaging the Power Take Off (PTO)

1. Push the power take off (PTO) switch to OFF.

## Operating the Attachment Lift Lever

The attachment lift lever (Fig. 30 & 31) is used to raise and lower various attachments.

### Raising Attachments

1. Start the tractor.
2. Pull the attachment lift lever upward until the latch locks. In this position, the lift will hold the attachment in the up, or raised position.

### WARNING

#### POTENTIAL HAZARD

- When the engine is off, attachments in the raised position can gradually lower.

#### WHAT CAN HAPPEN

- Someone nearby may be pinned or injured by the attachment as it lowers.

#### HOW TO AVOID THE HAZARD

- Always lower the attachment lift each time you shut off the tractor.

**IMPORTANT:** The tractor hood must be closed before the snowthrower is raised.

### Lowering Attachments

1. Start the tractor.

2. Push the attachment lift lever downward to lower the attachment.

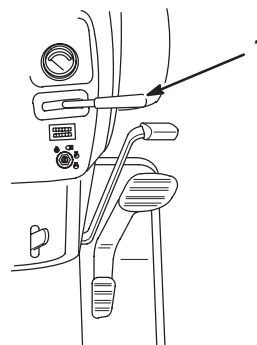

**Figure 30**

m-3258

1. Attachment lift lever

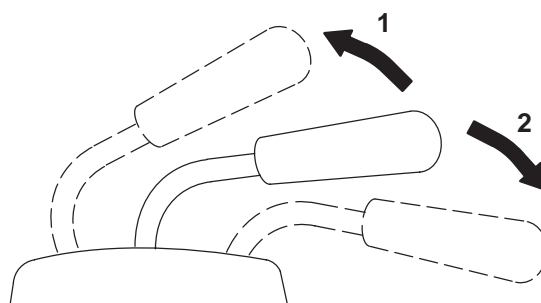

m-3315

**Figure 31**

1. Raise attachment
2. Lower attachment

## Adjusting The Discharge Chute

### DANGER

#### POTENTIAL HAZARD

- The rotating auger can cut off fingers, hands or other body parts and throw objects.

#### WHAT CAN HAPPEN

- Contact with the rotating auger and thrown debris can cause severe injury or even death.

#### HOW TO AVOID THE HAZARD

- Stay away from the discharge and auger openings while operating the snowthrower.
- Keep your hands, feet, and any other parts of your body or clothing away from concealed, moving or rotating parts.
- Use a stick, not your hand, to remove obstructions from the discharge chute or auger housing.
- Before adjusting, cleaning, repairing and inspecting the snowthrower and before unclogging the discharge chute, shut off the engine and wait for all moving parts to stop. Move the power take off (PTO) to “OFF” and rotate the ignition key to “OFF.” Remove the key.

The discharge chute can be rotated 180° side to side. The direction is controlled by turning the crank handle (Fig. 32).

The chute deflector, on top of the discharge chute, can be moved up and down to control the height and distance snow is thrown (Fig. 32).

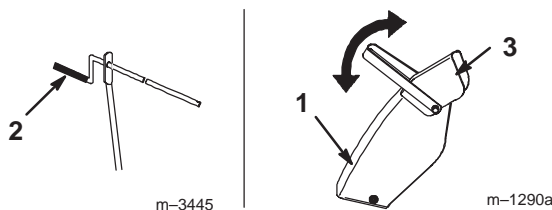

Figure 32

1. Discharge chute
2. Crank handle
3. Chute deflector

## Tips for Throwing Snow

Remove snow as soon as possible after it falls. This produces best snow removal results.

Adjust the skids to match the type of surface being cleaned; refer to Adjusting the Skids, page 20.

The snowthrower is designed to clean snow down to the contact surface, but there are times when the front of the snowthrower may tend to ride up. If this happens, reduce forward speed.

Discharge snow downwind whenever possible, and overlap each pass to ensure complete snow removal. If the wheels slip, shift into the High–Low range lever to Low “L” to reduce forward speed.

Run the snowthrower for a few minutes after clearing snow so moving parts do not freeze. Engage the power take off (PTO) to clear any remaining snow from the inside housing.

Do not overload the snowthrower by clearing snow at too fast a rate. If the engine slows down, reduce forward speed.

Always use full throttle (maximum engine speed) when throwing snow.

In wet or slushy conditions, clogging of the discharge chute will be reduced by maintaining maximum engine speed and by not overloading the engine.

In some snow and cold weather conditions, some controls and moving parts may freeze. Therefore, when any control becomes hard to operate, stop the machine and wait for all moving parts to stop; then check all parts for freeze up. **DO NOT USE EXCESSIVE FORCE AND TRY TO OPERATE THE CONTROLS WHEN FROZEN.** Free all controls and moving parts before operating.

Use low range (on the high–low range lever) for best performance and smoothest operation.

# Maintenance

## Service Interval Chart

Service Operation	Each Use	5 Hours	25 Hours	Storage Service	Fall Service	Notes
Drive shaft bearings—grease			X	X	X	
Drive chain—oil			X	X	X	
Gear box lubricant—check			X	X	X	
Belt—check for wear/cracks				X	X	
Chipped Surfaces—paint				X		
Scraper—check for wear				X	X	
Drive chain—adjust tension			X			

### CAUTION

#### POTENTIAL HAZARD

- If you leave the key in the ignition switch, someone could start the engine.

#### WHAT CAN HAPPEN

- Accidental starting of the engine could seriously injure you or other bystanders.

#### HOW TO AVOID THE HAZARD

- Remove the key from the ignition switch and pull the wire(s) off the spark plug(s) before you do any maintenance. Also push the wire(s) aside so it does not accidentally contact the spark plug(s).

## Greasing and Lubrication

### Service Interval Specification

Grease and oil the machine after every 25 operating hours or once a year, whichever occurs first.

**Grease Type:** General-purpose grease.

**Oil Type:** SAE 10W or 10W30.

### How to Grease

1. Disengage the power take off (PTO), set the parking brake, lower the attachment lift, and turn the ignition key to “STOP” to stop the engine. Remove the key.
2. Clean the grease fittings with a rag. Make sure to scrape any paint off the front of the fitting(s).
3. Connect a grease gun to the fittings. Pump grease into the fittings. Wipe up any excess grease.

## Where to Add Grease

1. Lubricate the jack shaft bearings (Fig. 33) and drive bearings (Fig. 34).

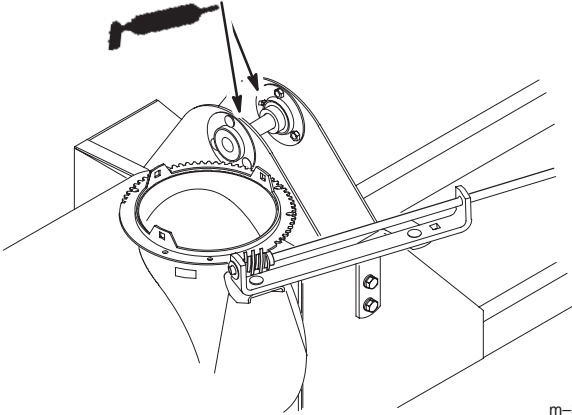

Figure 33

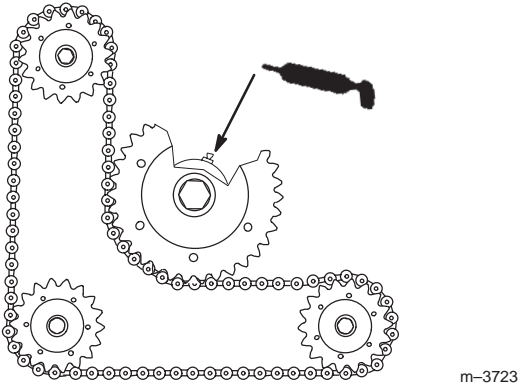

Figure 34

## Oil the Drive Chain

1. Disengage the power take off (PTO), set the parking brake, lower the attachment lift, and turn the ignition key to "STOP" to stop the engine. Remove the key.
2. Coat the entire chain with oil and allow it to penetrate each roller (Fig. 35).
3. Place a few drops of oil on the discharge chute rotator shaft and discharge chute mounting (Fig. 36).
4. Wipe off excess oil.

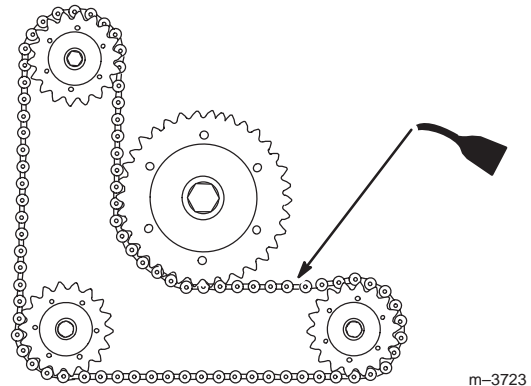

Figure 35

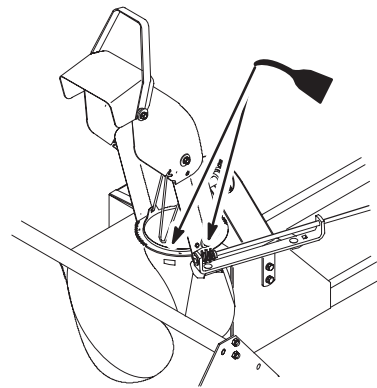
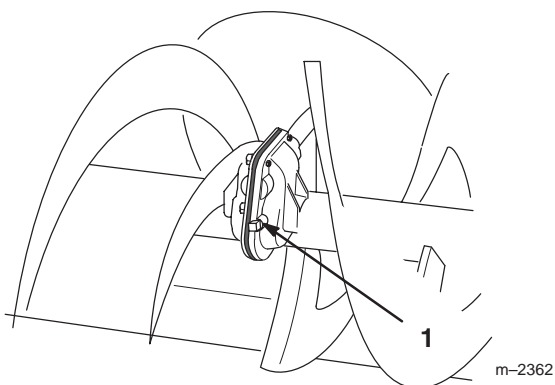

Figure 36

## Check Gear Box Lubricant

1. Move the snowthrower to a level surface. Disengage the power take off (PTO), set the parking brake, lower the attachment lift, and turn the ignition key to "OFF" to stop the engine. Remove the key.
2. Clean area around plug with a rag and remove plug (Fig. 37).
3. Add SAE 90 gear oil until level with bottom of hole in housing (Fig. 37).



**Figure 37**

1. Plug

## Replacing the Snowthrower Belt

Once each year, examine the drive belt for signs of wear and cracking. If any are found, purchase a belt from an Authorized Service Dealer and replace it as follows:

1. Remove the snowthrower from the tractor; refer to Removing the Snowthrower, page 11.
2. Remove the pulley cover from the snowthrower frame assembly, by removing the (4) #10 x 1/2" (13 mm) screws (Fig. 38).
3. Slide the pulley box out of the snowthrower frame (Fig. 38).

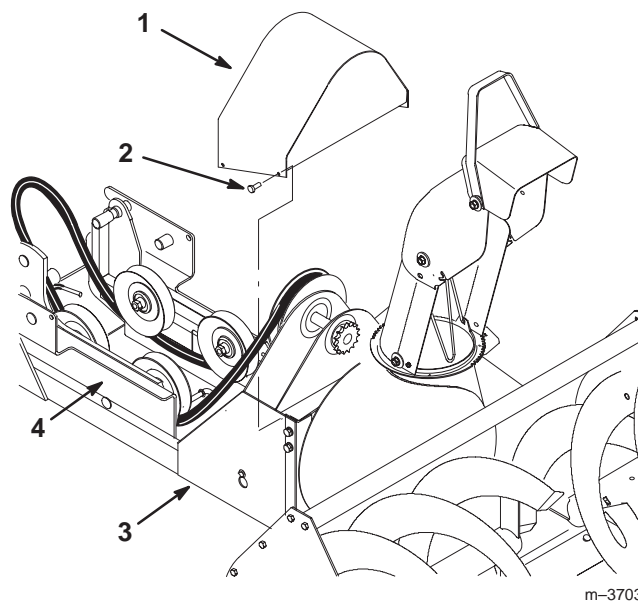

**Figure 38**

1. Pulley cover
2. Screw #10 x 1/2" (13 mm)
3. Snowthrower frame assembly
4. Pulley box

4. Remove the existing snowthrower belt.
5. Route the new snowthrower belt under the pulleys and inside the belt guide (Fig. 39).

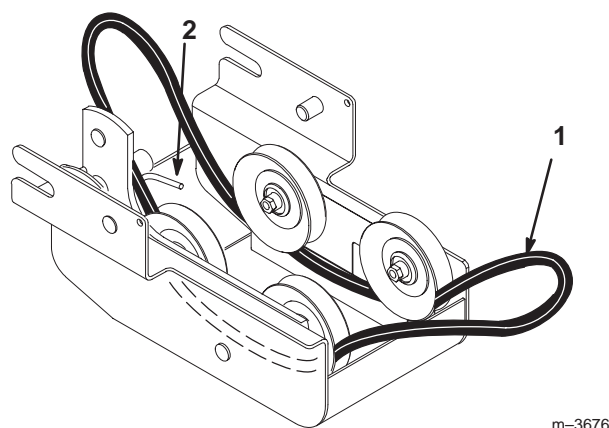

**Figure 39**

1. Snowthrower belt
2. Belt guide

- Slide the pulley box into the snowthrower frame (Fig. 40).
- Route the belt over the snowthrower pulley (Fig. 40).

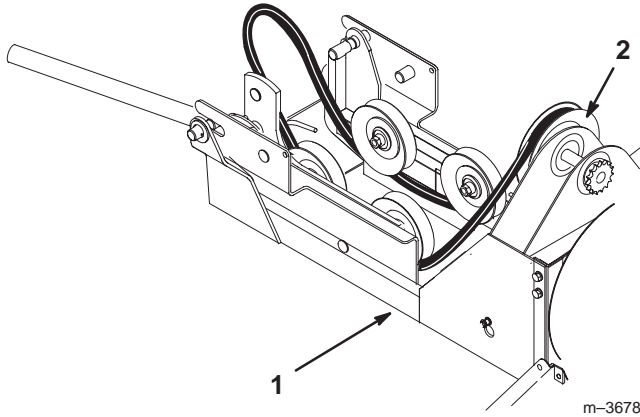

**Figure 40**

- Snowthrower frame
- Snowthrower pulley

- Attach the pulley cover to the snowthrower frame assembly with (4) #10 x 1/2" (13 mm) screws (Fig. 38).
- Install the snowthrower on the tractor; refer to Installing the Snowthrower on the Tractor, page 6.

## Adjusting the Skids

The distance between the scraper blade and the ground is controlled by skids on each side of the housing. The height can be adjusted so the scraper blade will not catch on uneven surfaces

- Move the snowthrower to a level surface.
- Disengage the power take off (PTO) and set the parking brake. Raise the attachment lift enough for the skids to clear the ground. Support the snowthrower housing off the ground. Turn the ignition key to "STOP" to stop the engine. Remove the key.
- Loosen the nuts securing the skids to the housing until the skids slide up and down easily (Fig. 41).

- Raise or lower the skids equally on both sides to obtain level scraping action, and tighten nuts securely (Fig. 41).

**Note:** On smooth, paved surfaces, the scraper blade can be close to the surface. On uneven, gravel or crushed rock surfaces, adjust the skids to raise the scraper, thereby preventing catching or picking up rocks.

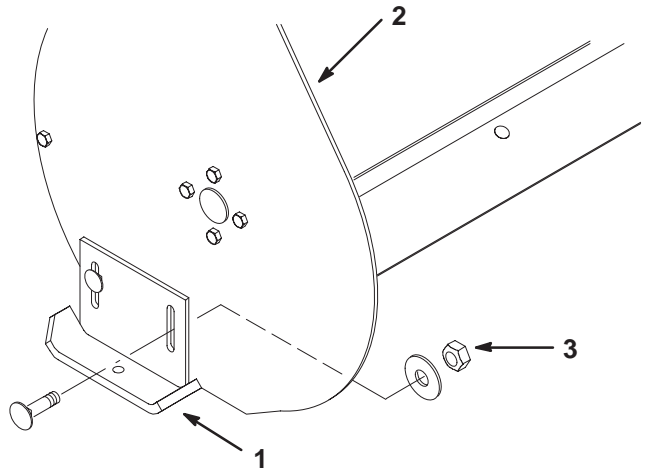

**Figure 41**

- Skid
- Housing
- Nuts and washers

**IMPORTANT:** The scraper should be higher above the pavement if the pavement surfaces on which the snowthrower will be used are cracked, rough or uneven.

## Replacing the Scraper Blade

The scraper blade contacts the ground preventing damage to the snowthrower housing. Periodically inspect the scraper blade for wear. When scraper becomes worn, before working surface contacts the housing, replace the scraper blade.

1. Disengage the power take off (PTO), set the parking brake, raise the attachment lift, and turn the ignition key to "STOP" to stop the engine. Remove the key.
2. Support the snowthrower housing off the ground.
3. Remove nuts, washers, carriage bolts and scraper blade (Fig. 42).
4. Replace scraper blade and install with previously removed hardware (Fig. 42).

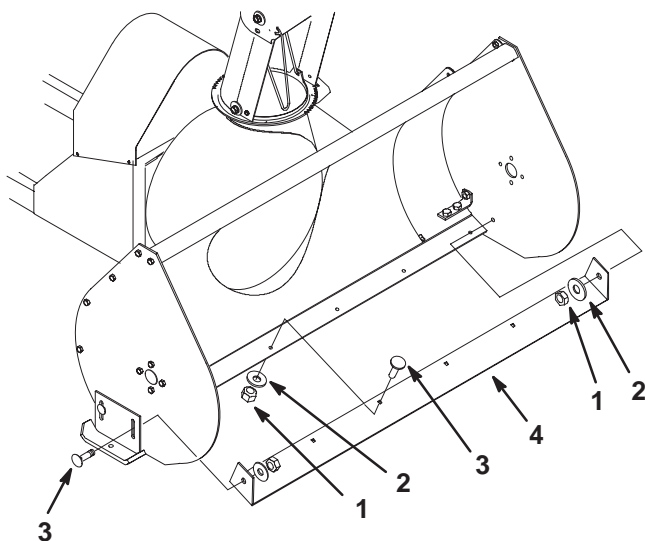

m-3722

**Figure 42**

- |           |                  |
|-----------|------------------|
| 1. Nut    | 3. Carriage bolt |
| 2. Washer | 4. Scraper blade |

## Adjusting Drive Chain Tension

Check the drive chain tension after every 25 operating hours or once a year, whichever occurs first. Adjust as necessary to maintain proper tension.

1. Disengage the power take off (PTO), set the parking brake, lower the attachment lift, and turn the ignition key to "STOP" to stop the engine. Remove the key.
2. To adjust, loosen the bolt that secures the idler sprocket. (Fig. 43).
3. Slide the idler sprocket in the adjustment slot until the chain is snug, but not tight ( $1/8''$  to  $1/2''$  deflection of the chain in the area indicated in Figure 43) and torque the bolt securing the sprocket to 67 to 83 ft lbs (90.8 to 112.5 Nm).

**IMPORTANT: Do not overtighten the chain or excessive wear will occur.**

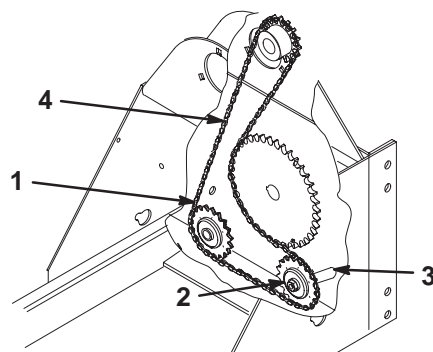

m-3795

**Figure 43**

- |                   |                         |
|-------------------|-------------------------|
| 1. Drive chain    | 3. Adjustment slot      |
| 2. Idler sprocket | 4. Test deflection here |

## Storage

1. Before long-term storage, wash the machine with mild detergent and water to remove dirt and grime from the entire machine.
2. Check the condition of the scraper blade; refer to Replacing the Scraper Blade, page 21.
3. Check the condition of the drive belt and chain.
4. Grease and oil the snowthrower; refer to Greasing and Lubrication, page 17.
5. Check and tighten all bolts, nuts, and screws. Repair or replace any part that is damaged or defective.
6. Paint all scratched or bare metal surfaces. Paint is available from your Authorized Service Dealer.
7. Coat the inside auger housing and discharge chute with automotive wax to prevent rust and reduce the sticking of snow to these surfaces.
8. Store the machine in a clean, dry garage or storage area. Cover the machine to protect it and keep it clean.