



Count on it.

Parts Catalog

HoverPro® 450 Machine

Model No. 02616—Serial No. 40000000 and Up



Ordering Replacement Parts

To order replacement parts, please supply the part number, the quantity, and the description of each part desired.

Understanding Reference Numbers

Each identified part in an illustration has a reference number. The reference number for a part also appears in the parts list, along with other information about the part.

This catalog uses two special reference number formats, one to indicate parts in a service assembly and another to indicate the quantity of a given part in an illustration.

Service Assembly Reference Numbers

Parts in service assemblies have reference numbers in the form a:b. The a represents the reference number of the entire service assembly and the b represents a sequential number unique to each part within the service assembly.

For example, a wheel assembly might be identified by reference number 6, the tire by 6:1, the valve by 6:2, and the wheel by 6:3. When you order the assembly identified by reference number 6, you receive all parts identified by reference numbers 6:1, 6:2, and 6:3. However, you may also order any part individually. Reference numbers of this type appear in illustration and in parts lists.

Reference Numbers Indicating Quantity

In an illustration, if a reference number indicates more than one part, the reference number has the form nX y. The n represents the quantity of the part, the X is the multiplication symbol, and the y represents the reference number.

For example, in an illustration, the reference number 2X 37 means that two of the parts identified by reference number 37 are indicated.

Contents

- Cutting Assembly 4
- Engine and Deck Assembly 6
- Handle Assembly 8
- Attachments and Accessories 10

Cutting Assembly

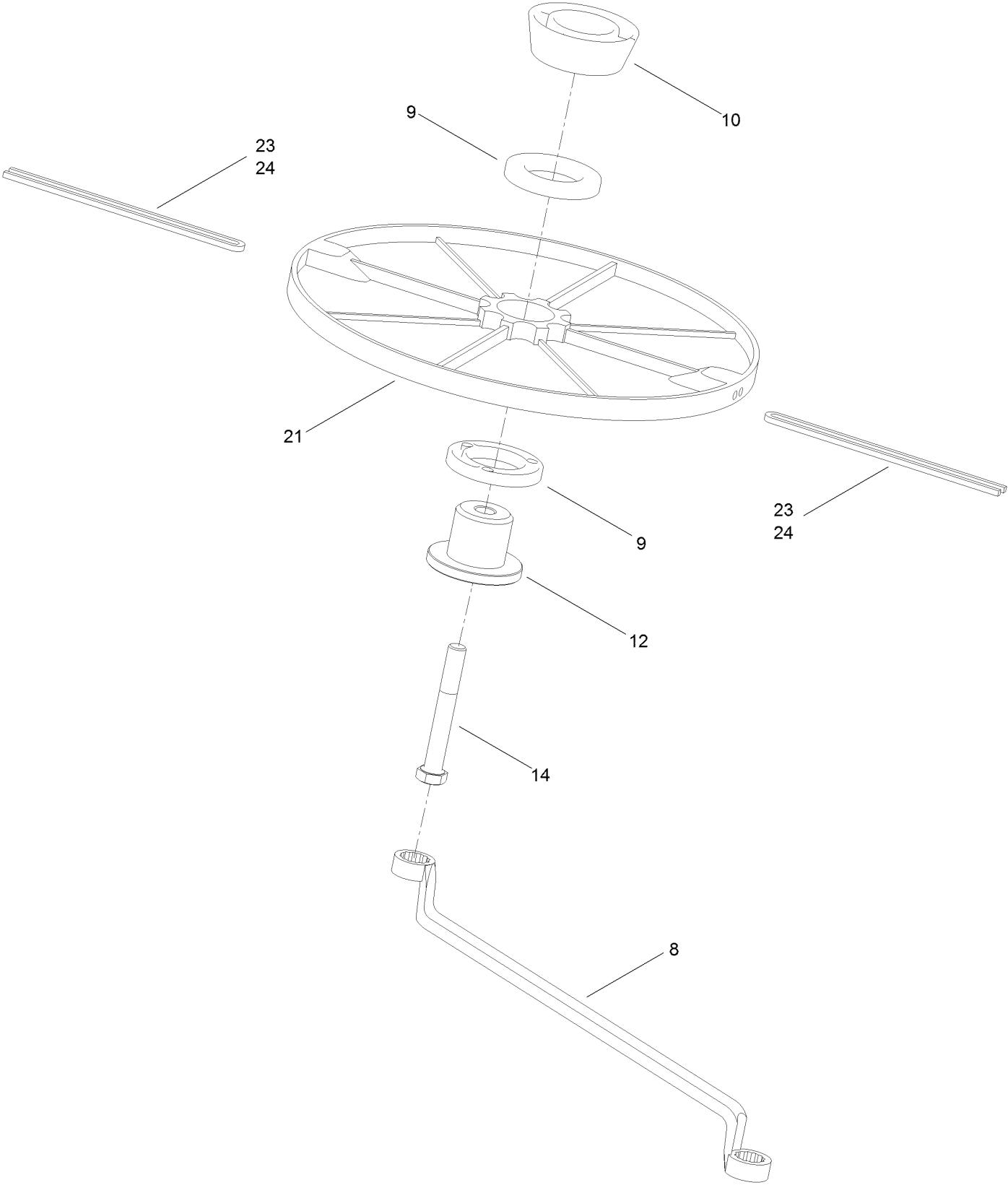

Cutting Assembly (continued)

<i>Ref.</i>	<i>Part Number</i>	<i>Qty.</i>	<i>Description</i>	<i>Ref.</i>	<i>Part Number</i>	<i>Qty.</i>	<i>Description</i>
8	H190210	1	Spanner	21	H292401	1	Disc-Safeway
9	H192025	2	Spacer-Blade, Aluminium	23	H292384	1	Flexiblade-3.5 MM, 143 Metres
10	H192270	1	Spacer-Distance	24	H292385	1	Flexiblade-3.5 MM, 27 Metres
12	H192272	1	Retainer-Blade				
14	H292018	1	Screw-Set				

Engine and Deck Assembly

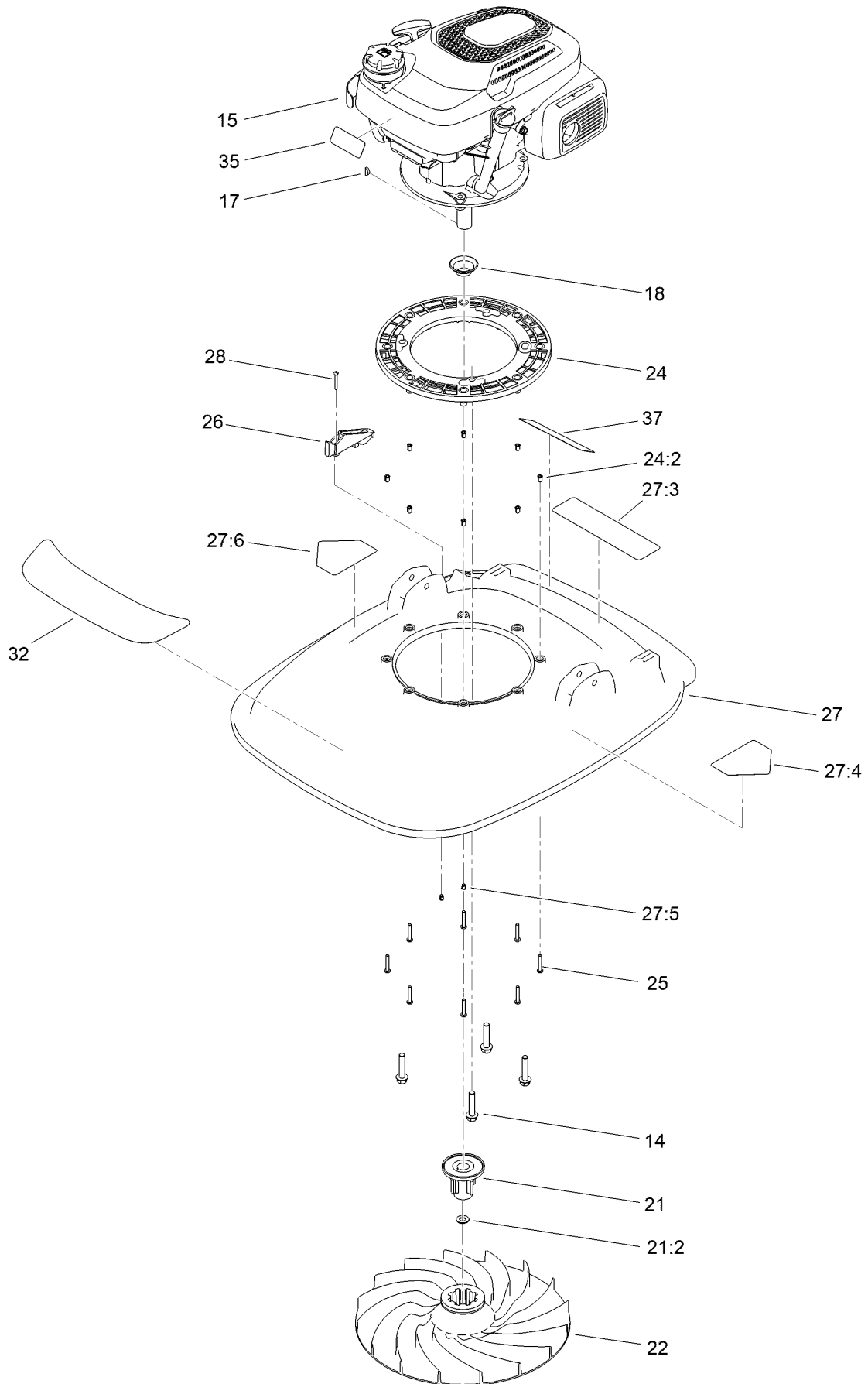

Engine and Deck Assembly (continued)

<i>Ref.</i>	<i>Part Number</i>	<i>Qty.</i>	<i>Description</i>	<i>Ref.</i>	<i>Part Number</i>	<i>Qty.</i>	<i>Description</i>
14	111-2157	4	Screw-Taptite	26	H292269	1	Bracket
15	134-6432	1	Engine-Honda (Gcvx170)	27	111-6003	1	Deck ASM
17	1662	1	Key-Woodruff	27:3	111-5393	1	Decal-Warning
18	H190118	1	Protector-Seal, Oil	27:4	94-8072	1	Decal-Danger
21	H290011	1	Drive And Spacer ASM	27:5	H292280	2	Insert
21:2	09479	1	Washer-Plain	27:6	111-9826	1	Decal-Danger
22	H192268	1	Impeller	28	H292279	2	Screw
24	H290003	1	Frame-Engine	32	111-5349	1	Decal-Hover Pro
24:2	H192266	8	Insert-Brass	35	130-8322	1	Decal-Warning, Ethanol
25	H292004	8	Set-Screw	37	133-8062	1	Decal-Arrestor, Spark

Handle Assembly

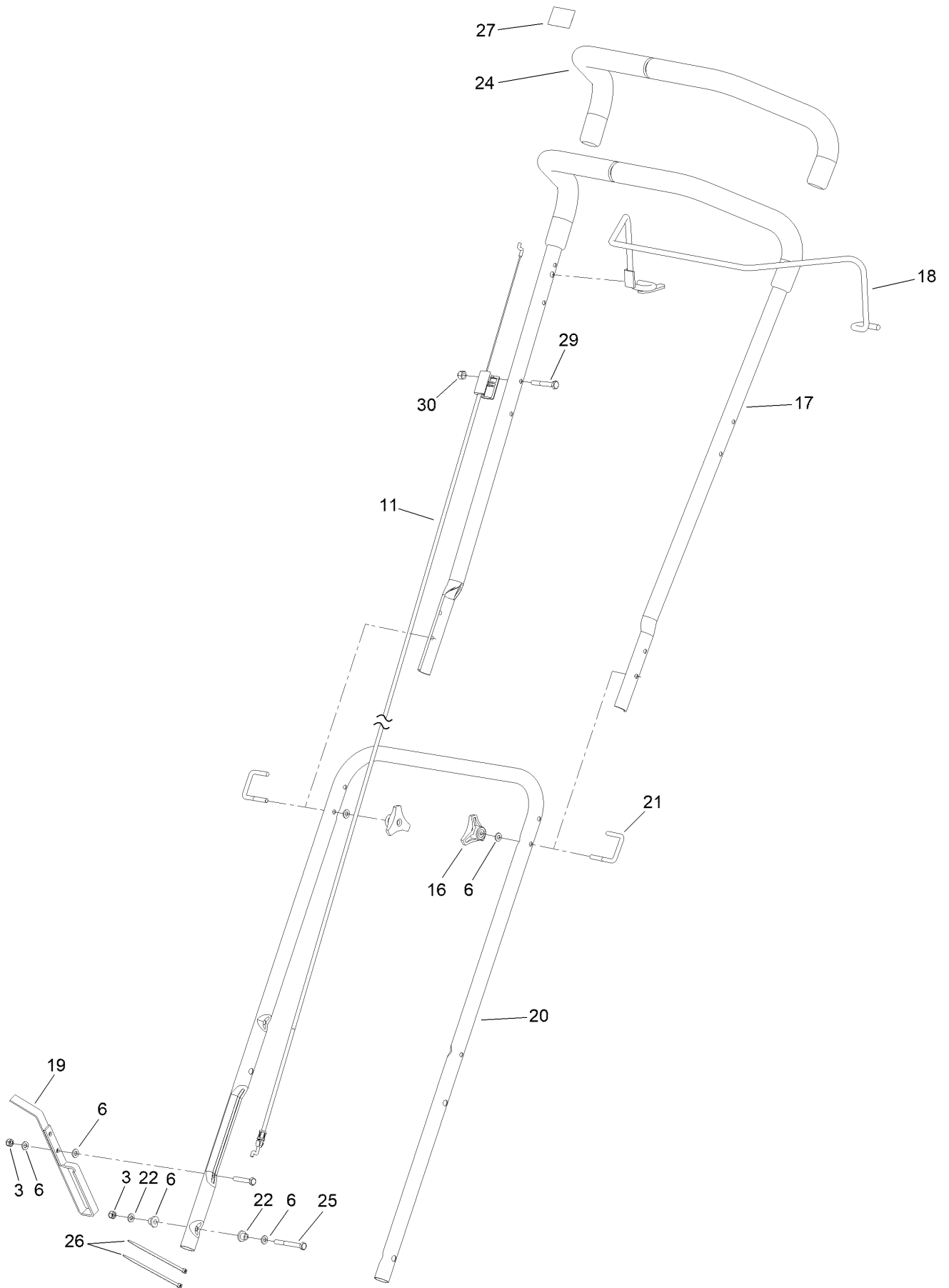

Handle Assembly (continued)

<i>Ref.</i>	<i>Part Number</i>	<i>Qty.</i>	<i>Description</i>	<i>Ref.</i>	<i>Part Number</i>	<i>Qty.</i>	<i>Description</i>
3	09438	3	Nut-Nyloc	21	H292026	2	Bolt-U
6	111-7679	8	Washer-Plain	22	H292058	4	Spacer-Handle
11	134-6958	1	OPC Cable	24	H292276	2	Grip-Handle
16	H192204	2	Handwheel	25	H292309	2	Bolt-Hex
17	H290237	1	Handle-Upper	26	HY3966	2	Tie-Cable
18	H290239	1	Arm-Bail	27	H295159	1	Decal-Stop
19	H290286	1	Footstop	29	05010	1	Bolt
20	111-7260-03	1	Handle-Lower	30	137-3088	1	Nut-Hex

Attachments and Accessories

For 02616 HoverPro 450 Machine

Product Name	Model/Part
Transport Wheel Kit	02622
Handlebar Extension Kit	02623

Notes:



Count on it.