



Greensmaster[®] 3100
2 Wheel Drive Traction Unit
Model No. 04356—210000701 and Up

Parts Catalog

Ordering Replacement Parts

To order replacement parts, please supply: the part number, the quantity, and the description of each part desired.

Understanding Reference Numbers

Each identified part in an illustration has a reference number. The reference number for a part also appears in the parts list, along with other information about the part.

This catalog uses two special reference number formats, one to indicate parts in a service assembly and another to indicate the quantity of a given part in an illustration.

Service Assembly Reference Numbers

Parts in service assemblies have reference numbers in the form **a:b**. The **a** represents the reference number of the entire service assembly and the **b** represents a sequential number unique to each part within the service assembly.

For example, a wheel assembly might be identified by reference number **6**, the tire by **6:1**, the valve by **6:2**, and the wheel by **6:3**. When you order the assembly identified by reference number **6**, you receive all parts identified by reference numbers **6:1**, **6:2**, and **6:3**. However, you may also order any part individually.

Reference numbers of this type appear in illustrations and in part lists.

Reference Numbers Indicating Quantity

In an illustration, if a reference number indicates more than one part, the reference number has the form **nX y**. The **n** represents the quantity of the part, the **X** is the multiplication symbol, and the **y** represents the reference number.

For example, in an illustration, the reference number **2X 37** means that two of the parts identified by reference number **37** are indicated.

Contents

Description	Page	Description	Page
Control Pedal Assembly	4	Electrical Schematic	37
Control Pedal Assembly (Continued)	5	Grass Basket Assembly and Miscellaneous Parts	38
Traction Controls Assembly	6	Hydraulic Schematic	39
Front Wheel and Brake Assembly	7	Cylinder Assembly Briggs and Stratton Model 350447-1259-E1	40
Hydraulic Drive Motor Assembly No. 92-9199 .	8	Crankshaft Assembly Briggs and Stratton Model 350447-1259-E1	41
Steering Arm Assembly	9	Cylinder Head Assembly Briggs and Stratton Model 350447-1259-E1	42
Power Steering Valve Assembly No. 92-8690 .	10	Intake Manifold and Rocker Cover Assembly Briggs and Stratton Model 350447-1259-E1	43
Right Hand Pull Frame Assembly	11	Carburetor Assembly Briggs and Stratton Model 350447-1259-E1	44
Hydraulic Cylinder Assembly No. 99-8159	12	Governor Assembly Briggs and Stratton Model 350447-1259-E1	45
Left Hand Pull Frame Assembly	13	Alternator Assembly Briggs and Stratton Model 350447-1259-E1	46
Rear Pull Frame Assembly	14	Fuel Pump, Oil Pump and Dipstick Assembly Briggs and Stratton Model 350447-1259-E1	47
Hydraulic Cylinder Assembly No. 99-8160	16	Air Cleaner Assembly Briggs and Stratton Model 350447-1259-E1	48
Seat Assembly	17	Blower Housing Assembly Briggs and Stratton Model 350447-1259-E1	49
Control Valve Installation Assembly	18	Flywheel Assembly Briggs and Stratton Model 350447-1259-E1	50
Control Valve Installation Assembly (Continued)	19	Starter Assembly Briggs and Stratton Model 350447-1259-E1	51
Control Valve Assembly No. 105-3800	20	Gasket Assembly Briggs and Stratton Model 350447-1259-E1	52
Section 1 Assembly No. 105-3801	21	Carburetor Overhaul Kit Assembly Briggs and Stratton Model 350447-1259-E1	53
Section 2 Assembly No. 105-3802	22		
Section 3 Assembly No. 105-3803	23		
Section 4 Assembly No. 105-3804	24		
Section 5 Assembly No. 93-1386	25		
Engine Installation Assembly	26		
Hydraulic Pump Installation Assembly	27		
Hydraulic Pump Assembly No. 92-9764	28		
Frame Assembly	29		
Rear Wheel Assembly	30		
Hydraulic Cylinder Assembly No. 83-2330	31		
Control Panel Assembly	32		
Hydraulic Reservoir Assembly	33		
Fuel Tank Assembly	34		
Reel Motor Installation Assembly	35		
Reel Motor Assembly No. 94-3506	36		

Accessories

Description	Model / Part No.	Description	Model / Part No.
Individual Reel Shut Off Kit	28-2150	8 Blade, 4 Bolt (Heavy Duty) Cutting Unit	04404
Basket Reinforcement Kit	26-0900	8 Blade, 4 Bolt Cutting Unit	04408
Thatching Reels	04493	11 Blade, 4 Bolt Cutting Unit	04406
Variable Speed Kit	04422	8 Blade, SPA Cutting Unit	04468
Traction Tire	231-124	11 Blade, SPA Cutting Unit	04450
Armrests	30707	8 Blade, 4 Bolt Cutting Unit	04470
Spiker	04494	11 Blade, 4 Bolt Cutting Unit	04471
Tri-Roller	04495	8 Blade, SPA Cutting Unit	04472
Backlapping Kit	92-9656	11 Blade, SPA Cutting Unit	04473
Backlap Kit - 2 Speed, 3 Position	94-1870	Three Wheel Drive Kit	100-6441

Part Description Abbreviations

Part descriptions in this catalog may include the following abbreviations.

Abbreviation	Meaning	Abbreviation	Meaning
AR	as required	HYD	hydraulic
ASM	assembly	INC	incorporated
CARR	carriage	LH	left hand
DEG	degrees	NI	nylon insert
FH	flat head	PPH	Phillips pan head
GA	gauge	PTH	Phillips truss head
HF	hex flange	PTO	power take off
HH	hex head	RH	right hand
HHF	hex head flange	SFH	slotted fillister head
HLH	hex lag head	SHH	slotted hex head
HJ	hex jam	SQH	square head
HOC	height-of-cut	SHWH	slotted hex washer head
HS	hex socket	SPH	slotted pan head
HSBH	hex socket button head	SRH	slotted round head
HSFH	hex socket flat head	STD	standard
HSH	hex socket head	TAP	self tapping
HWH	hex washer head	TTH	Torx truss head
HWHTF	hex washer head thread forming	WH	wing head

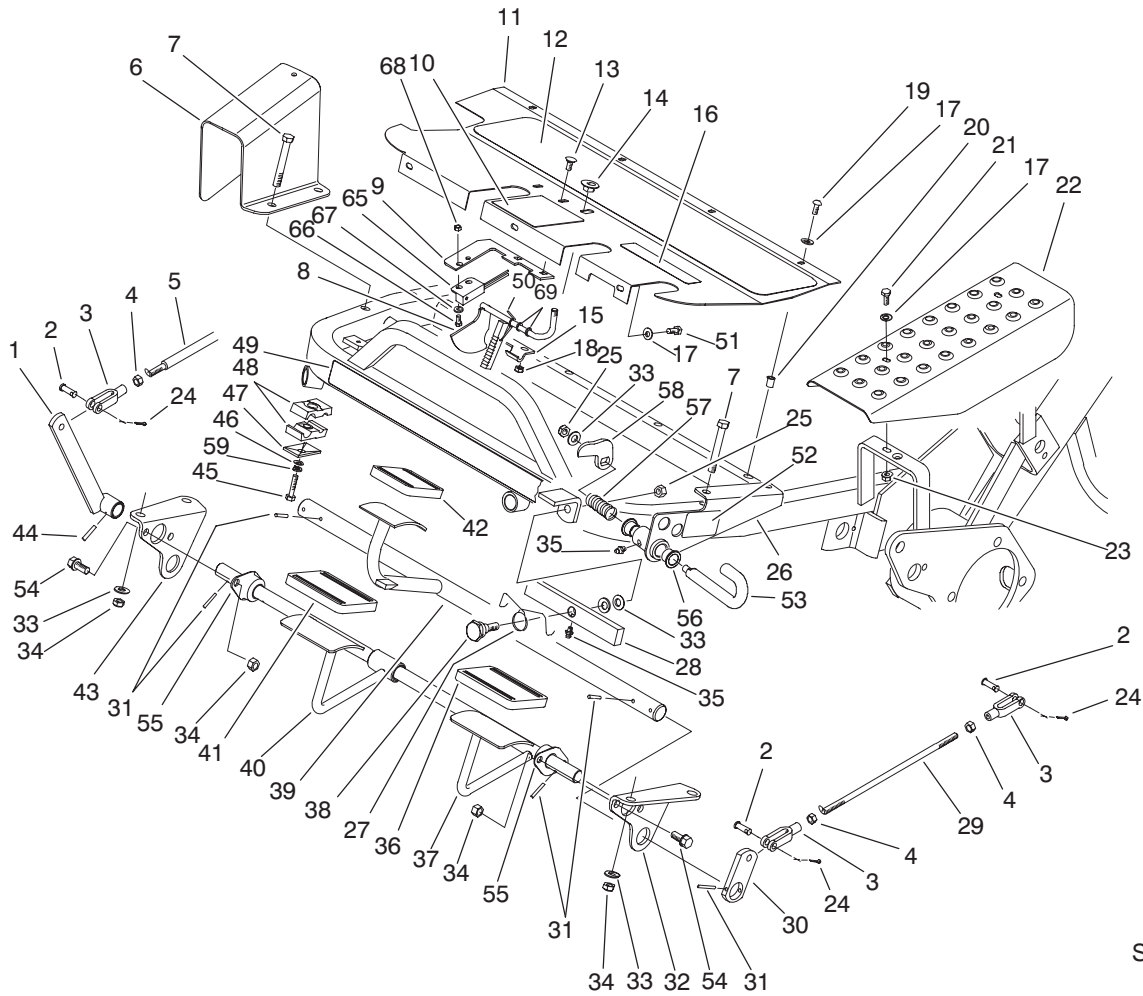

Sheet No.: 2

Control Pedal Assembly

Ref. No.	Part No.	Qty.	Description
1	49-6200-01	1	Lever-Cutting
2	283-61	5	Pin-Yoke
3	282-2	5	Yoke
4	3220-2	5	Nut
5	49-5430	1	Rod-Control
6	49-6110-01	1	Guard
7	323-13	4	Screw-HH
8	100-9819	1	Latch ASM
9	100-9821	1	Plate-Switch, Reed
10	93-8062	1	Decal-Brake, Parking
11	83-0640-01	1	Plate-Footrest
12	49-6120	1	Pad-Footrest
13	3229-11	2	Screw-CARR
14	32141-111	1	Nut-Adjusting
15	95-1629	1	Hinge-Lower
16	93-8075	1	Decal-Mow/Lift
17	3256-1	9	Washer-Flat
18	3296-16	2	Nut-Lock, NI
19	3274-31	4	Screw-HSBH
20	32148-6	8	Nut-Insert
21	321-4	2	Screw-HH
22	83-0200-01	1	Plate-Cover, LH
23	32128-33	2	Nut-HF
24	3272-6	5	Pin-Cotter
25	3296-39	2	Nut-Lock, NI
26	93-9901-01	1	Bracket-Lockout, Mow

Ref. No.	Part No.	Qty.	Description
27	83-0080	1	Spring-Pivot, Lift
28	83-0060	1	Lift-Pivot
29	27-2270	2	Rod-Adjustment, Brake
30	10-8100-01	2	Strap-Shaft, Brake
31	32121-35	8	Pin-Roll
32	88-9640-01	1	Bracket-Lift Pivot, LH
33	3256-24	7	Washer-Flat
34	3296-59	8	Nut-Lock NI
35	302-5	2	Fitting-Grease
36	93-7631	1	Pad-Foot, Lift
37	88-9660	1	Shaft-Control, Cut
38	83-2590	1	Bolt-Shoulder, Pivot
39	83-0160	1	Shaft-Brake
40	83-0140	1	Pedal-Mow
41	93-7630	1	Pad-Foot
42	93-7629	1	Pad-Foot, Brake
43	88-9630-01	1	Bracket-Lift Pivot, RH
44	32121-6	1	Pin-Roll
45	321-11	1	Screw-HH
46	3256-22	1	Washer-Flat
47	69-9760	1	Coverplate
48	56-7970	2	Clamp-Tube
49	88-9620	1	Decal-Gr3100
50	10-8140	1	Bracket-Spring, Latch
51	321-3	3	Screw-HH

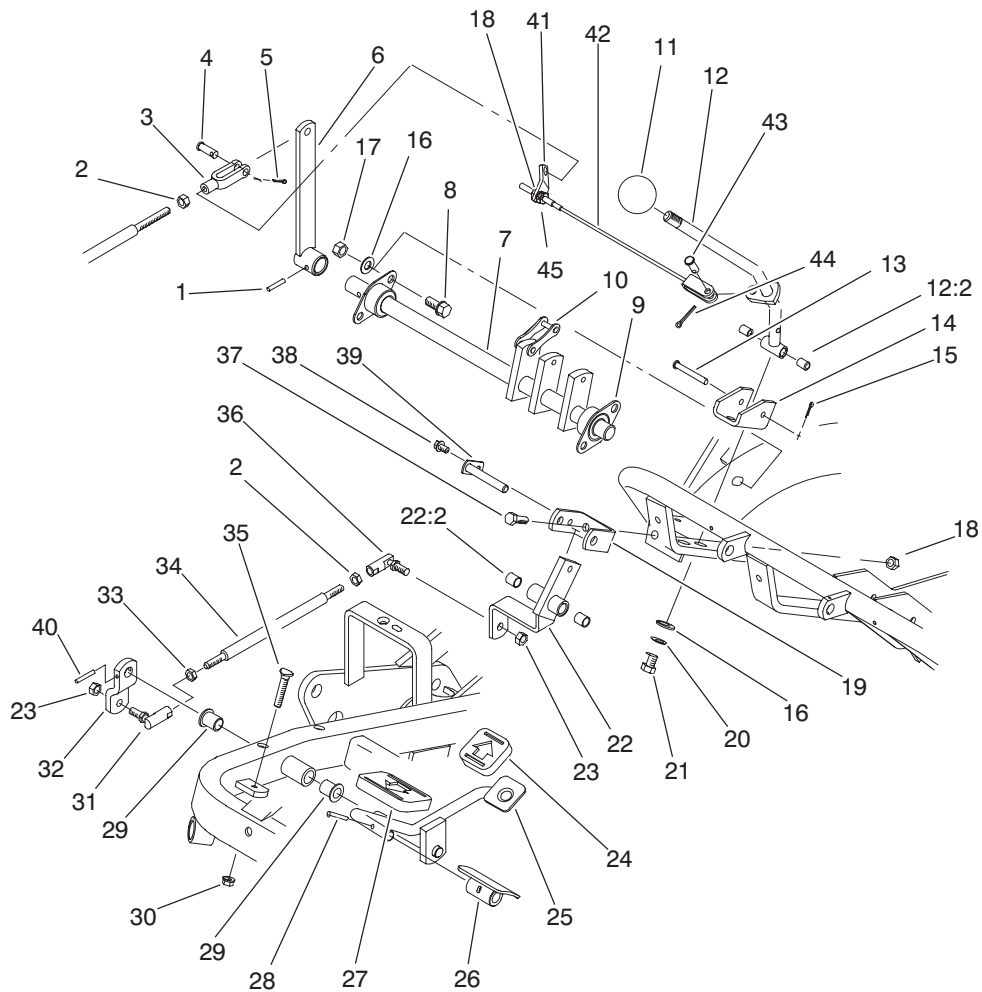

Sheet No.: 3

Traction Controls Assembly

Ref. No.	Part No.	Qty.	Description
1	32121-6	1	Pin-Roll
2	3220-2	3	Nut
3	282-2	1	Yoke
4	283-61	1	Pin-Yoke
5	3272-6	1	Pin-Cotter
6	47-5320-01	1	Lever
7	44-0870	1	Cam Shaft ASM
8	3234-1	4	Screw-HHF
9	27-2320	2	Bearing
10	57-6220	5	Link-Connecting
11	233-48	1	Knob
12	93-9934	1	Handle-Traction
12:2	256-251	2	Bushing
13	283-57	1	Pin
14	49-6220	1	Bracket-Arm, Control
15	3272-4	1	Pin-Cotter
16	3256-24	6	Washer-Flat
17	3296-59	4	Nut-Lock NI
18	3296-29	3	Nut-Lock NI
19	49-6250	1	Bracket-Pivot
20	3254-6	2	Washer-Lock, Internal
21	3211-2	2	Screw-HH
22	49-6260	1	Pivot ASM
22:2	256-2	2	Bushing
23	3296-4	2	Nut-Lock, NI
24	74-9110	1	Pad-Pedal, Reverse

Ref. No.	Part No.	Qty.	Description
25	83-0540-01	1	Traction Pedal ASM
26	49-6440-03	1	Pedal-Forward
27	74-9100	1	Pad-Pedal, Forward
28	32121-45	1	Pin-Spring
29	256-155	2	Bushing-Flange
30	32128-20	1	Nut-HF
31	2411-42	1	Joint-Ball, LH
32	83-0630	1	Arm-Pivot, Traction
33	3220-20	1	Nut-Jam
34	83-0580	1	Rod-Control, Traction
35	17-9420	1	Screw-Handle
36	2411-43	1	Joint-Ball
37	322-5	2	Screw-HH
38	12-3270	1	Screw
39	49-6290	1	Pivot Shaft ASM
40	32121-51	1	Pin-Roll
41	93-9936	1	Bracket-Return, Traction
42	93-9937	1	Traction Cable ASM
43	283-62	1	Pin-Clevis
44	3272-10	1	Pin-Cotter
45	3217-6	1	Nut-Hex

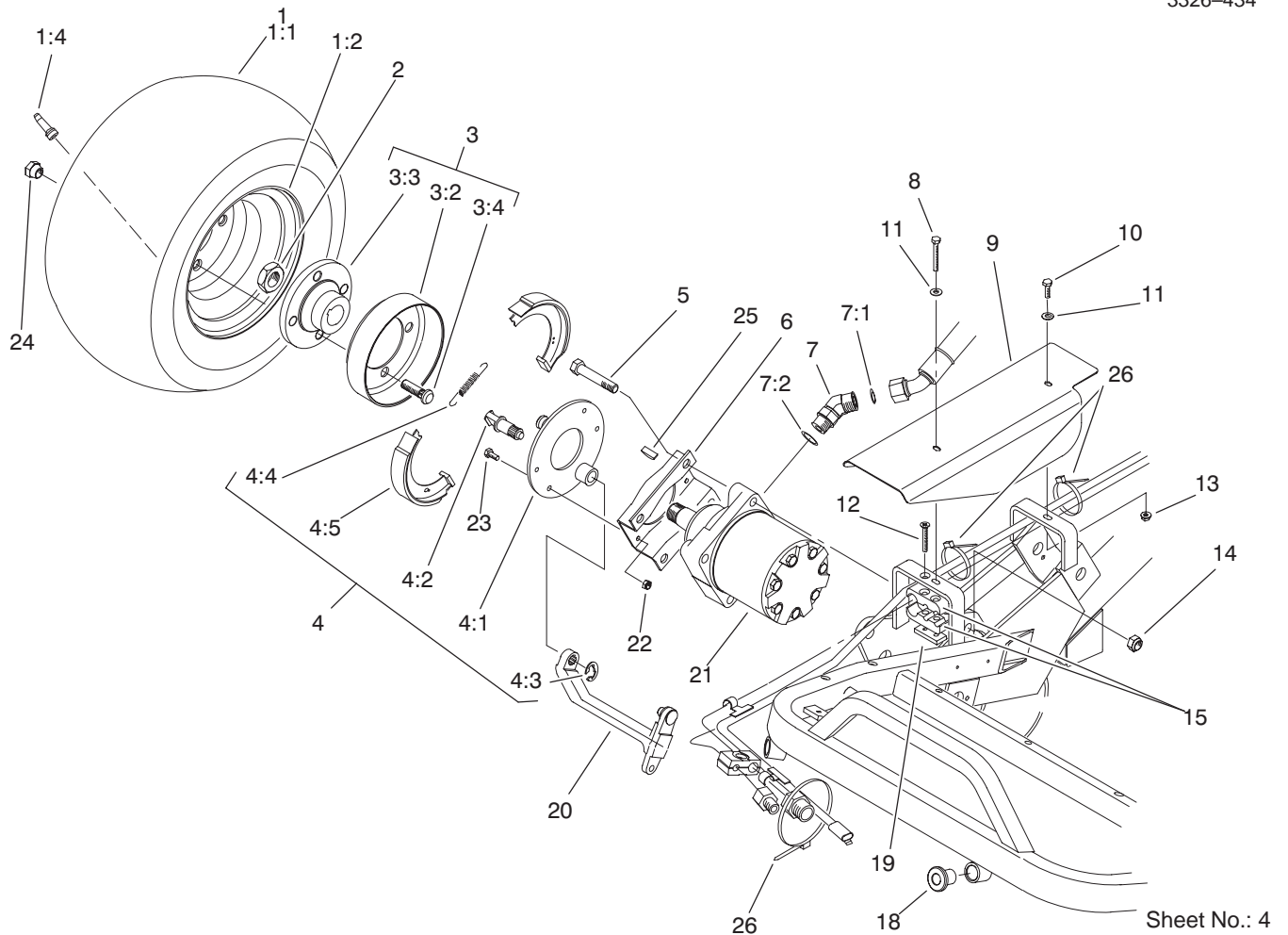

Front Wheel and Brake Assembly

Ref. No.	Part No.	Qty.	Description
☆1		2	Wheel & Tire ASM
1:1	28-3680	1	Tire
1:2	217-60	1	Rim
1:4	232-24	1	Stem-Valve
*1:5	232-37	1	Tube
2	26-3790	2	Nut-Lock
3	10-6821	2	Brake Drum ASM
3:2	10-6850	1	Drum-Brake
3:3	10-6870-03	1	Hub-Wheel
3:4	85-6540	4	Stud-Drive
4	104-7705	2	Brake ASM
4:1	70-9870	1	Plate-Backing
4:2	104-7707	1	Cam Shaft-Brake
4:3	104-7706	1	E-Ring-Bowed
4:4	70-9880	2	Spring-Return
4:5	70-9840	2	Shoe-Brake
5	325-11	8	Screw-HH
6	84-2000-03	2	Bracket-Brake
7	340-14	4	Fitting-Hyd, 45°
7:1	237-65	1	O-Ring
7:2	237-80	1	O-Ring
8	321-11	1	Screw-HH
9	83-0190-01	1	Cover-RH
10	321-4	1	Screw-HH
11	3256-22	2	Washer-Flat
12	32108-100	1	Screw-FH

Ref. No.	Part No.	Qty.	Description
13	32128-33	1	Nut-HF
14	3296-23	8	Nut-Lock, NI
15	57-6140	2	Clamp-Tube, Half
18	83-1700	2	Bushing-Flange
19	83-1220	1	Plate-Clamp
20	93-2096	2	Lever-Brake
21	92-9199	2	Motor-Hyd, Wheel
22	3296-42	8	Nut-Lock, NI
23	321-5	8	Screw-HH
24	242-50	8	Nut-Lug
25	3257-42	2	Key-Woodruff
26	3290-378	3	Tie-Cable

- ☆ Not serviced
* Not illustrated

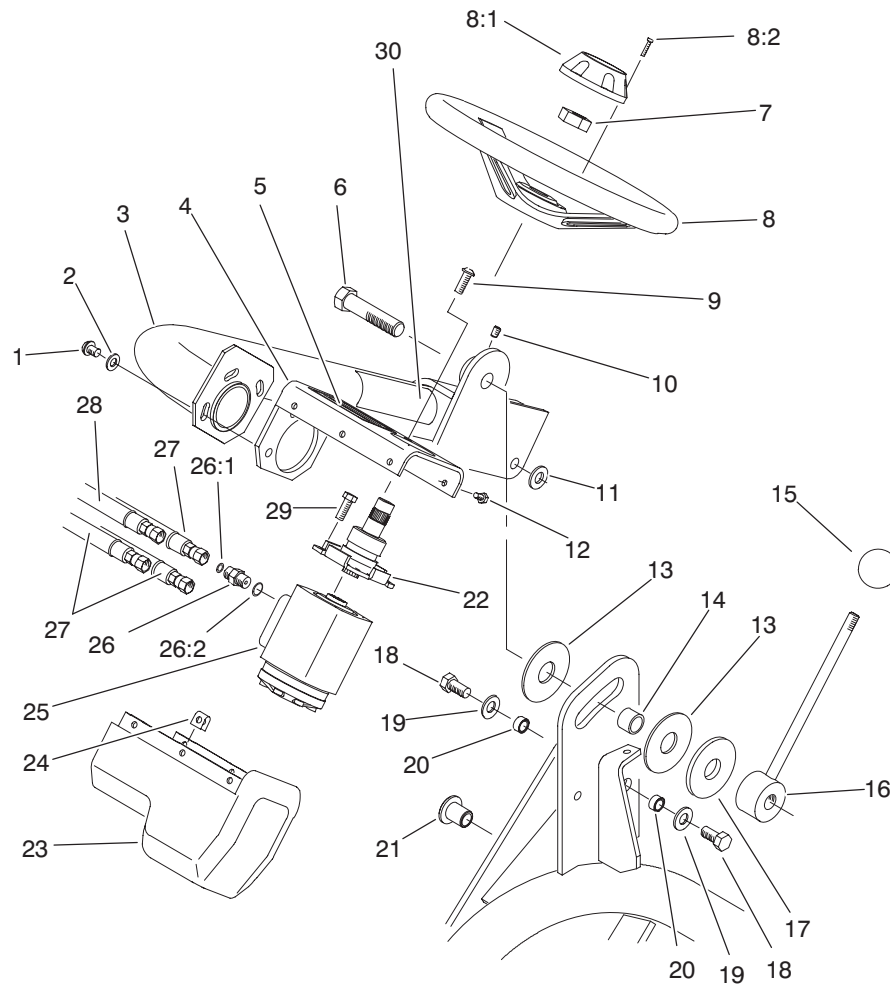

Sheet No.: 5

Steering Arm Assembly

Ref. No.	Part No.	Qty.	Description
1	3274-80	3	Screw-HH
2	3256-80	3	Washer-Flat
3	83-0650-01	1	Arm-Steering
4	83-0780-03	1	Support-Valve, Steering
5	93-8063	1	Decal-Warning (Europe)
5	104-2053	1	Decal-Warning
6	83-0750	1	Capscrew-HH, LH Thread
7	47-6990	1	Nut
8	68-5130	1	Wheel-Steering
8:1	68-5140	1	Cap-Wheel, Steering
8:2	32144-21	1	Screw
9	3274-63	2	Screw-HSH
10	3242-2	1	Screw-SQH
11	65-6390	1	Washer-Thrust, Plain
12	3274-39	6	Screw-HSBH
13	83-0740	2	Disc-Friction
14	83-0730	1	Spacer-Lockup
15	233-48	1	Knob
16	83-0700-03	1	Handle-Lockup
17	83-0760	1	Spacer-Plate, Lockup
18	325-4	2	Screw-HH
19	3256-26	2	Washer-Flat
20	47-2890	2	Bushing

Ref. No.	Part No.	Qty.	Description
21	83-1700	1	Bushing-Flange
22	83-1420	1	Column-Steering
23	83-0810	1	Cover-Steering
24	3290-277	6	Nut-Speed
25	92-8690	1	Valve-Control, Steering
26	340-1	4	Adapter
26:1	237-35	1	O-Ring
26:2	237-42	1	O-Ring
27	83-1350	3	Hose-Hyd
28	83-1360	1	Hose-Hyd
29	323-4	2	Screw-HH
30	93-8068	1	Decal-Arm, Steering

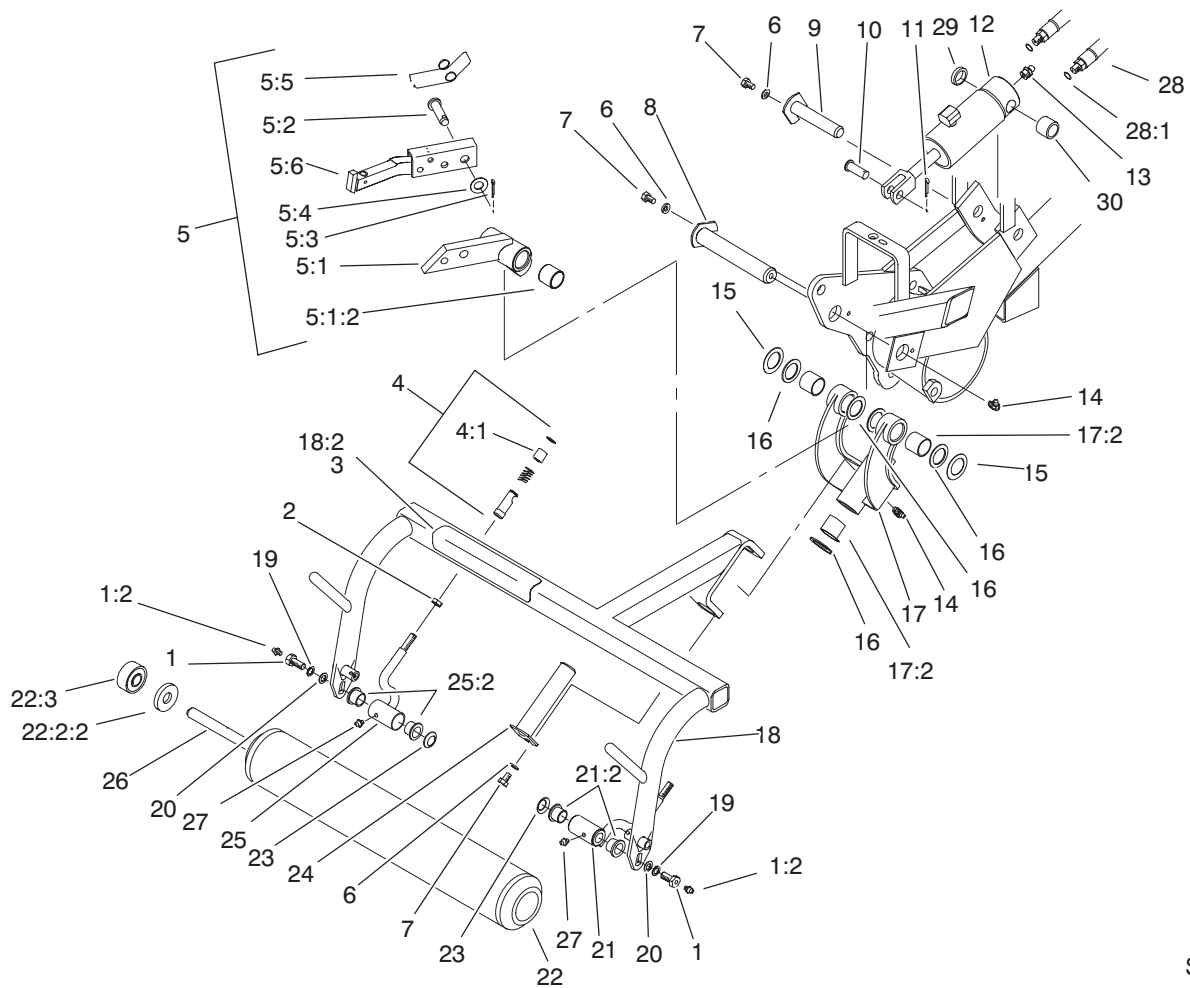

Sheet No.: 6

Right Hand Pull Frame Assembly

Ref. No.	Part No.	Qty.	Description
1	11-0160	2	Roller Shaft Screw ASM
1:2	302-5	1	Fitting-Grease
2	3220-3	2	Nut-Jam
3	93-8064	1	Decal-Danger (Europe)
4	99-1460	2	Ball Joint Receiver ASM
4:1	99-1461	1	Sleeve-Joint, Ball
☆5		1	RH Lift Arm ASM
5:1	62-2440	1	Lift Arm ASM
5:1:2	3-0348	2	Bushing
5:2	63-8750	1	Pin-Pivot
5:3	3272-11	1	Pin-Cotter
5:4	3256-26	1	Washer-Flat
5:5	57-7650	1	Spring-Torsion
5:6	94-5588-01	1	Bar-Lift
6	3256-23	3	Washer-Flat
7	322-1	3	Screw-HH
8	10-6110	1	Pin-Hinge
9	10-6060	1	In-Pivot, Ram
10	283-8	1	Pin-Clevis
11	3272-11	1	Pin-Cotter
12	99-8159	1	Hyd Cylinder ASM
13	302-2	1	Fitting-Grease
14	302-60	2	Fitting-Lube

Ref. No.	Part No.	Qty.	Description
15	5-1226	2	Washer
16	10-8110	6	Washer-Thrust
17	10-7820	1	Pivot Hinge ASM
17:2	3-0348	4	Bushing
18	104-2055	1	Right Pull Frame ASM
18:2	62-5070	1	Decal-Warning
19	3253-21	2	Washer-Lock
20	3256-24	2	Washer-Flat
21	92-0586	1	Pull Arm ASM
21:2	3-1506	2	Bushing
22	99-4277	1	Roller ASM
☆22:2		2	Hub Yoke ASM
22:2:2	253-83	1	Seal-Oil
22:3	251-141	2	Bearing-Ball
23	3290-317	2	Washer-Spring
24	10-6090	1	Pin-Pivot
25	92-0585	1	Pull Arm ASM
25:2	3-1506	2	Bushing
26	21-8470	1	Shaft-Roller
27	302-5	2	Fitting-Grease
28	92-9767	2	Hose
28:1	237-78	1	O-Ring
29	105-3828	1	Spacer
30	74-3730	1	Spacer-Spindle, Rear

☆ Not serviced

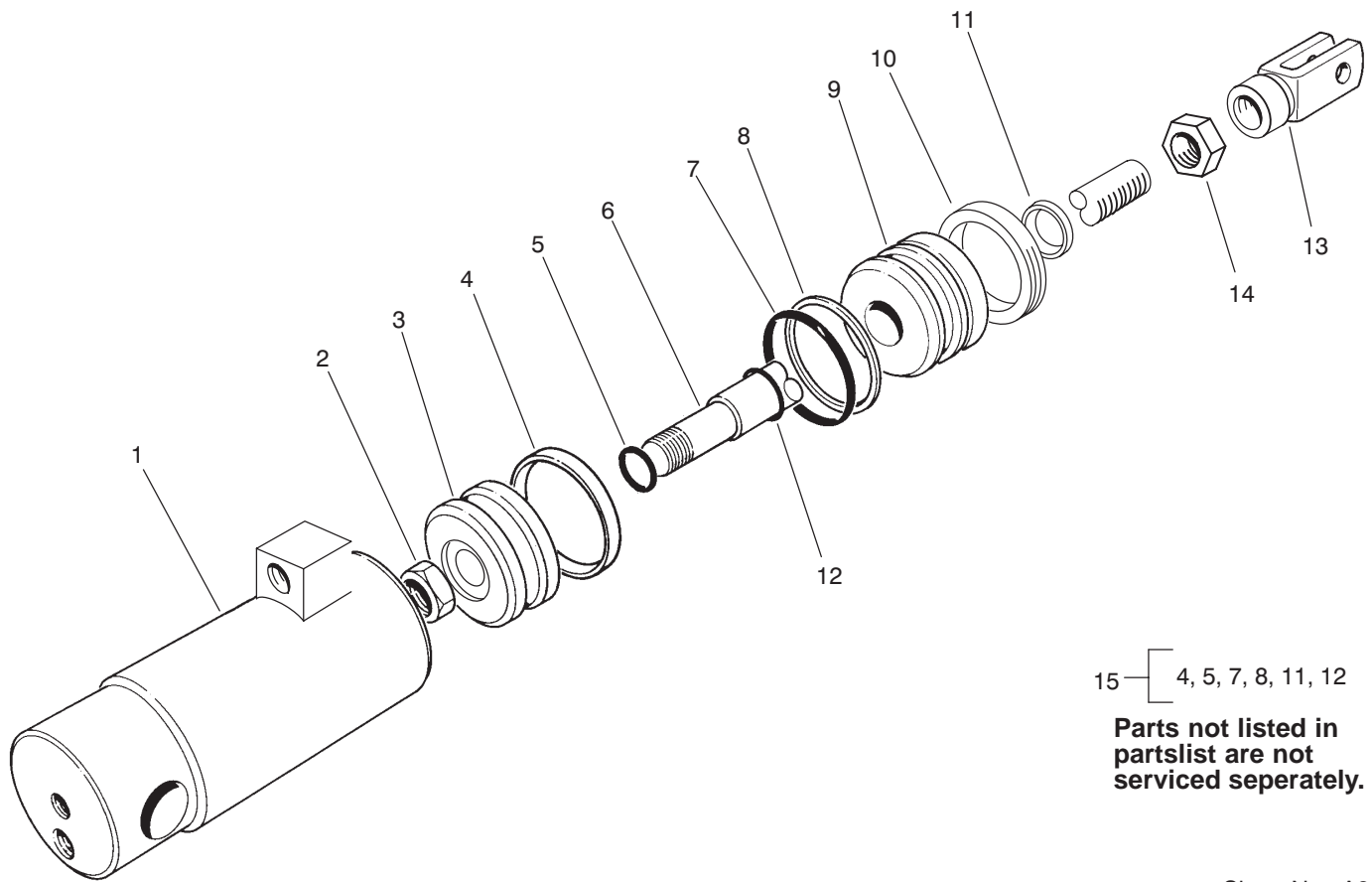

15 — [4, 5, 7, 8, 11, 12]
Parts not listed in partslist are not serviced seperately.

Sheet No.: A3
 T-3154-1

Hydraulic Cylinder Assembly No. 99-8159

Ref. No.	Part No.	Qty.	Description
2	32152-10	1	Locknut-Deform, Top
3	52-1990	1	Piston-Cylinder, Hyd
13	76-1850	1	Clevis
14	3220-6	1	Nut-Jam
15	99-8163	1	Kit-Repair, Seal

Ref. No.	Part No.	Qty.	Description

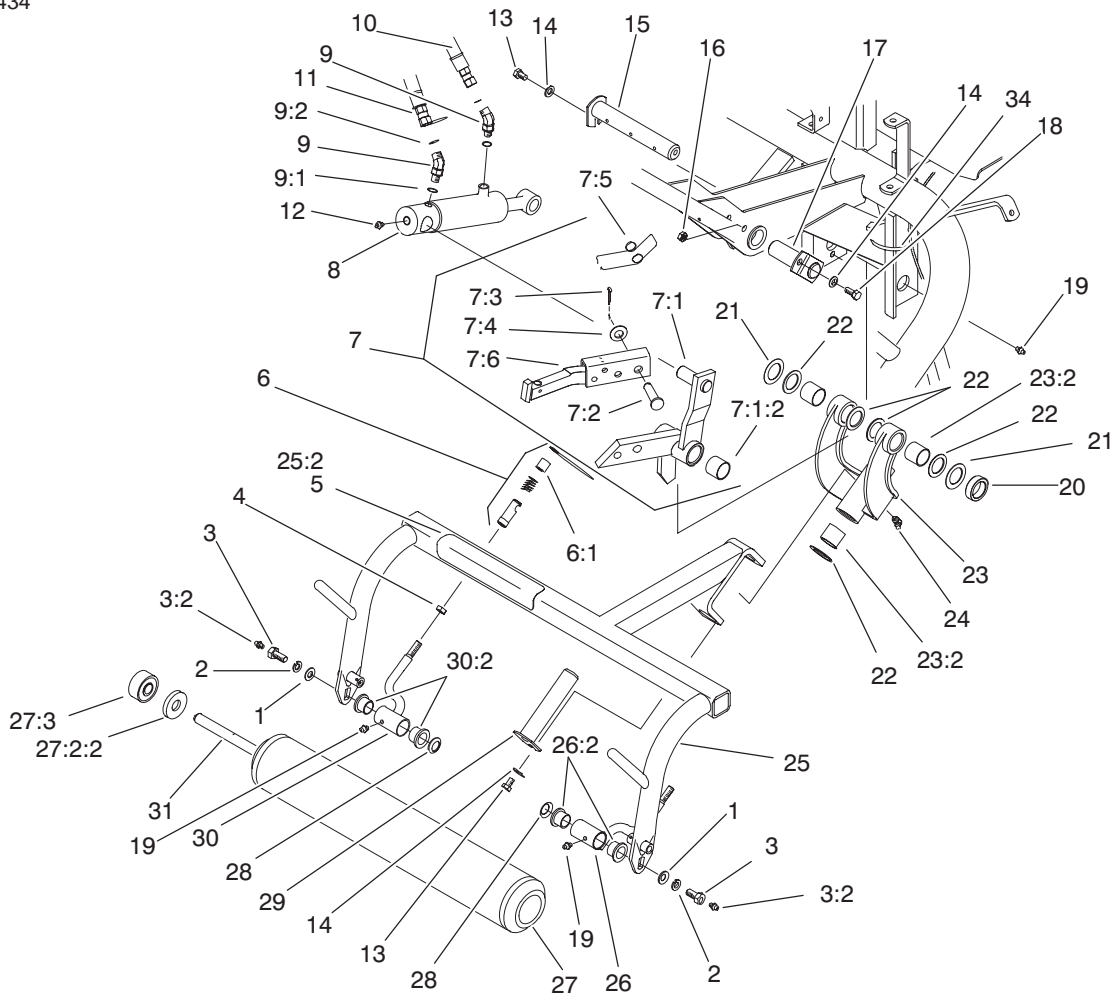

Sheet No.: 8

Rear Pull Frame Assembly

Ref. No.	Part No.	Qty.	Description
1	3256-24	2	Washer-Flat
2	3253-21	2	Washer-Lock
3	11-0160	2	Roller Shaft Screw
3:2	302-5	1	Fitting-Grease
4	3220-3	2	Nut-Jam
5	93-8064	1	Decal-Danger (Europe)
6	99-1460	2	Ball Joint Receiver ASM
6:1	99-1461	1	Sleeve-Joint, Ball
☆7		1	Center Lift Arm ASM
7:1	68-5380	1	Center Lift Arm ASM
7:1:2	3-0348	2	Bushing
7:2	63-8750	1	Pin-Pivot
7:3	3272-11	1	Pin-Cotter
7:4	3256-26	1	Washer-Flat
7:5	57-7650	1	Spring-Torsion
7:6	62-2420-01	1	Bar-Lift
8	99-8160	1	Hyd Cylinder ASM
9	340-103	2	Fitting-Hyd, 45°
9:1	237-78	1	O-Ring
9:2	237-21	1	O-Ring
10	83-1680	1	Hose-Hyd
11	88-9700	1	Hose-Hyd
12	302-2	1	Fitting-Grease

Ref. No.	Part No.	Qty.	Description
13	322-1	2	Screw-HH
14	3256-23	3	Washer-Flat
15	27-2550	1	Pin-Hinge
16	3296-29	1	Nut-Lock NI
17	68-5560	1	Pin-Cylinder, Pivot
18	322-3	1	Screw-HH
19	302-5	3	Fitting-Grease
20	93-2384	1	Spacer-Carrier
21	5-1226	2	Washer
22	10-8110	6	Washer-Thrust
23	10-7820	1	Pivot Hinge ASM
23:2	3-0348	4	Bushing
24	302-60	1	Fitting-Lube
25	104-2056	1	Rear Pull Frame ASM
25:2	62-5070	1	Decal-Warning
26	92-0586	1	Pull Arm ASM
26:2	3-1506	2	Bushing
27	99-4277	1	Roller ASM
☆27:2		2	Hub Yoke ASM
27:2:2	253-83	1	Seal-Oil
27:3	251-141	2	Bearing-Ball
28	3290-317	2	Washer-Spring
29	10-6090	1	Pin-Pivot
30	92-0585	1	Pull Arm ASM
30:2	3-1506	2	Bushing
31	21-8470	1	Shaft-Roller

☆ Not serviced

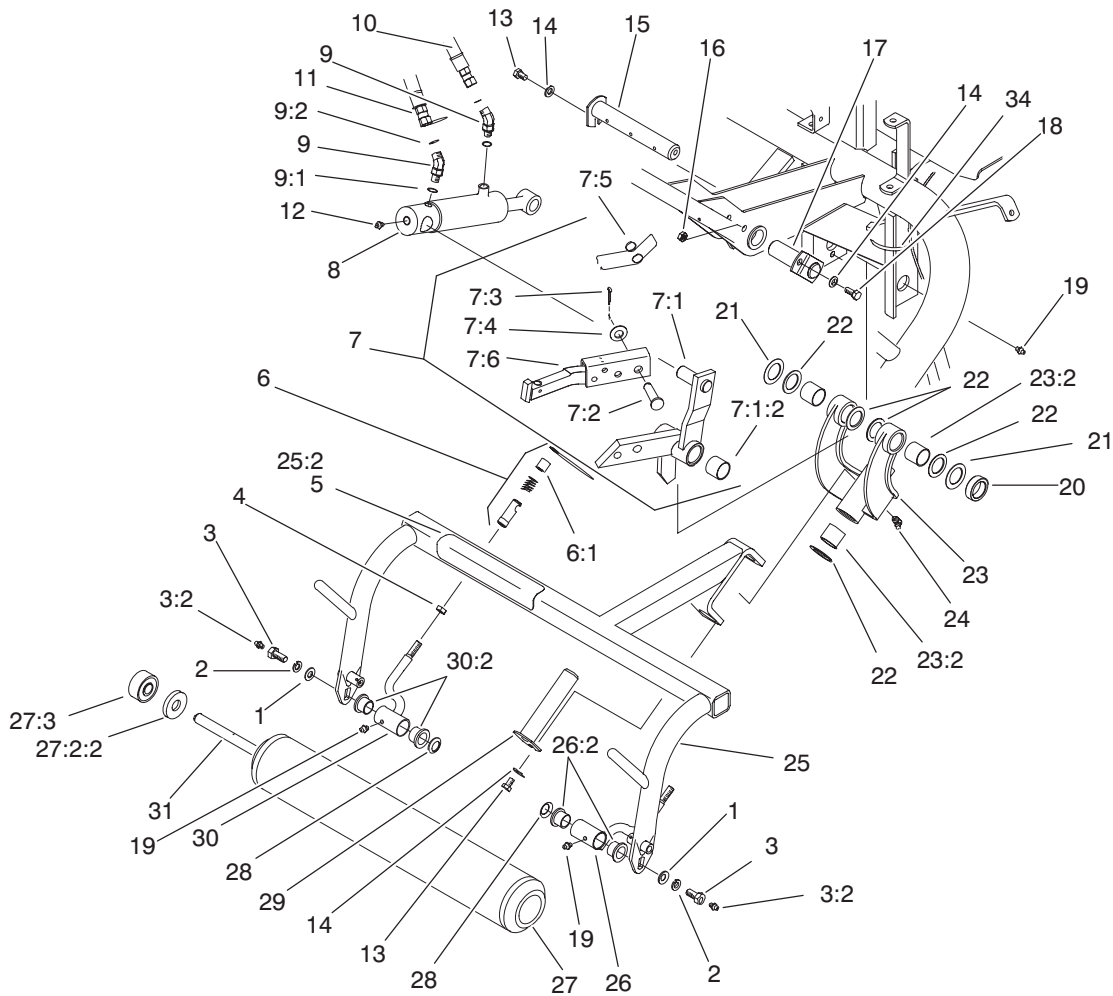

Sheet No.: 8

Rear Pull Frame Assembly

Ref. No.	Part No.	Qty.	Description
34	3290-379	1	Tie-Cable

Ref. No.	Part No.	Qty.	Description

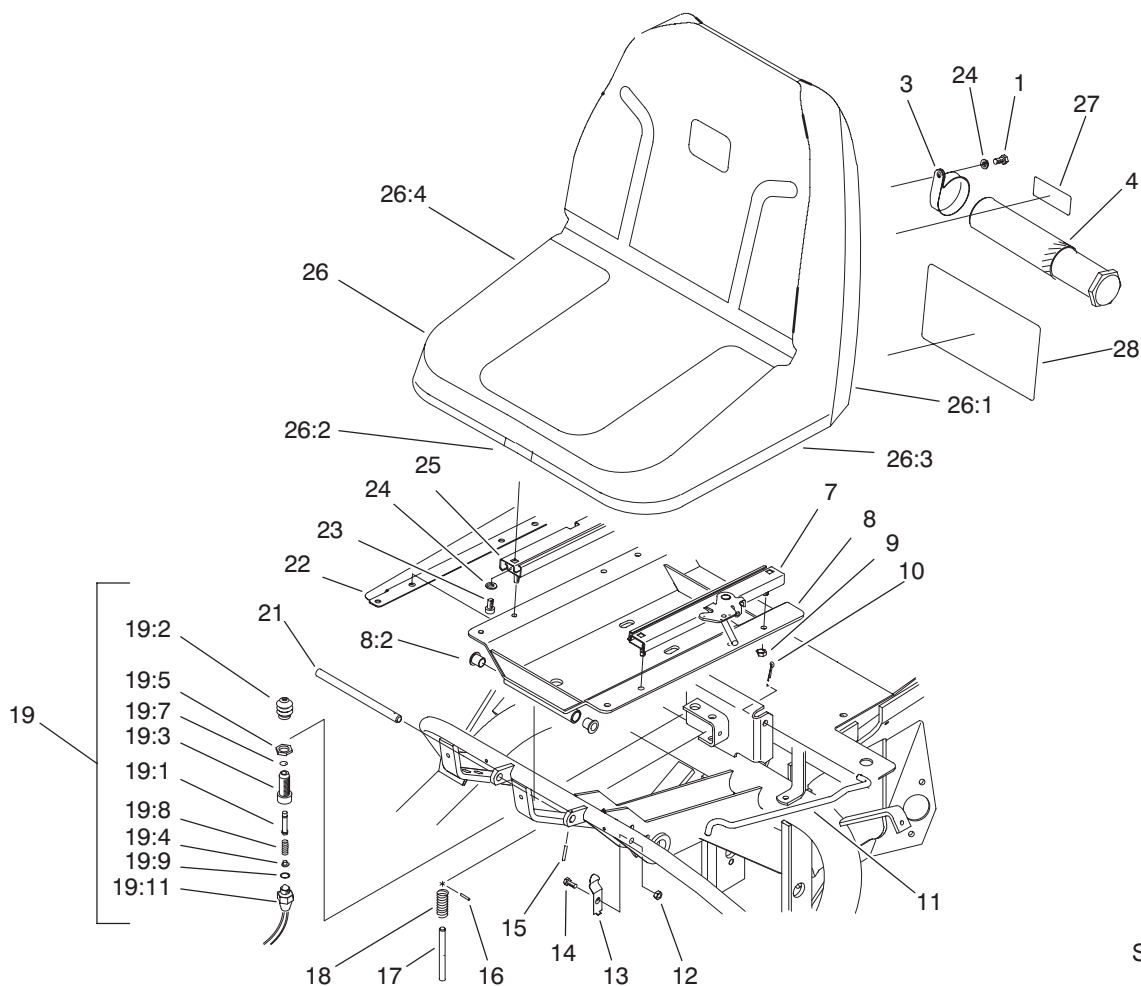

Sheet No.: 9

Seat Assembly

Ref. No.	Part No.	Qty.	Description	Ref. No.	Part No.	Qty.	Description
1	322-2	2	Screw-HH	21	49-5880	1	Shaft-Support, Seat
3	2412-133	2	R-Clamp	22	83-1840-01	1	Cover-Valve, RH
4	74-0720	1	Tube-Manual	23	3274-12	4	Screw-HSH
7	51-0790	1	Adjuster-Seat, LH	24	3256-23	6	Washer-Flat
8	83-1270	1	Seat Support ASM	25	51-0780	1	Slider-Seat
8:2	256-155	2	Bushing-Flange	26	100-3187	1	Seat ASM
9	3296-29	4	Nut-Lock NI	26:1	92-6534	1	Shell
10	3272-11	1	Pin-Cotter	26:2	351-80	1	Clip
11	68-5100	1	Rod-Seat, Prop	26:3	351-78	1	Edging
12	3296-16	1	Nut-Lock, NI	26:4	100-6411	1	Cushion-Replacement
13	68-5310	1	Clip-Rod, Prop	27	93-8067	1	Decal-Oil, Hyd
14	321-3	1	Screw-HH	28	93-7260	1	Decal-Danish
15	32121-45	1	Pin-Spring	28	93-7259	1	Decal-Finnish
16	3284-3	1	Pin-Groove	28	84-9260	1	Decal-German
17	51-0350	1	Pin-Spring, Seat	28	83-2490	1	Decal-Japanese
18	3-6685	1	Spring	28	84-9240	1	Decal-Spanish
19	43-9071	1	Limit Switch ASM	28	84-9250	1	Decal-French
19:1	43-8860	1	Plunger-Switch	28	84-9270	1	Decal-Swedish
19:2	43-8870	1	Boot-Switch	28	84-9280	1	Decal-Italian
19:3	43-8620	1	Pin-Guide, Switch	28	93-7257	1	Decal-Portugese
19:4	43-8610	1	Guide	28	93-7258	1	Decal-Norwegian
19:5	218-461	2	Nut-HH	28	93-7261	1	Decal-Dutch
19:7	237-7	1	O-Ring	28	94-8036	1	Decal-Service
19:8	43-8600	1	Spring-Compression				
19:9	237-30	1	O-Ring				
19:11	72-4320	1	Switch				

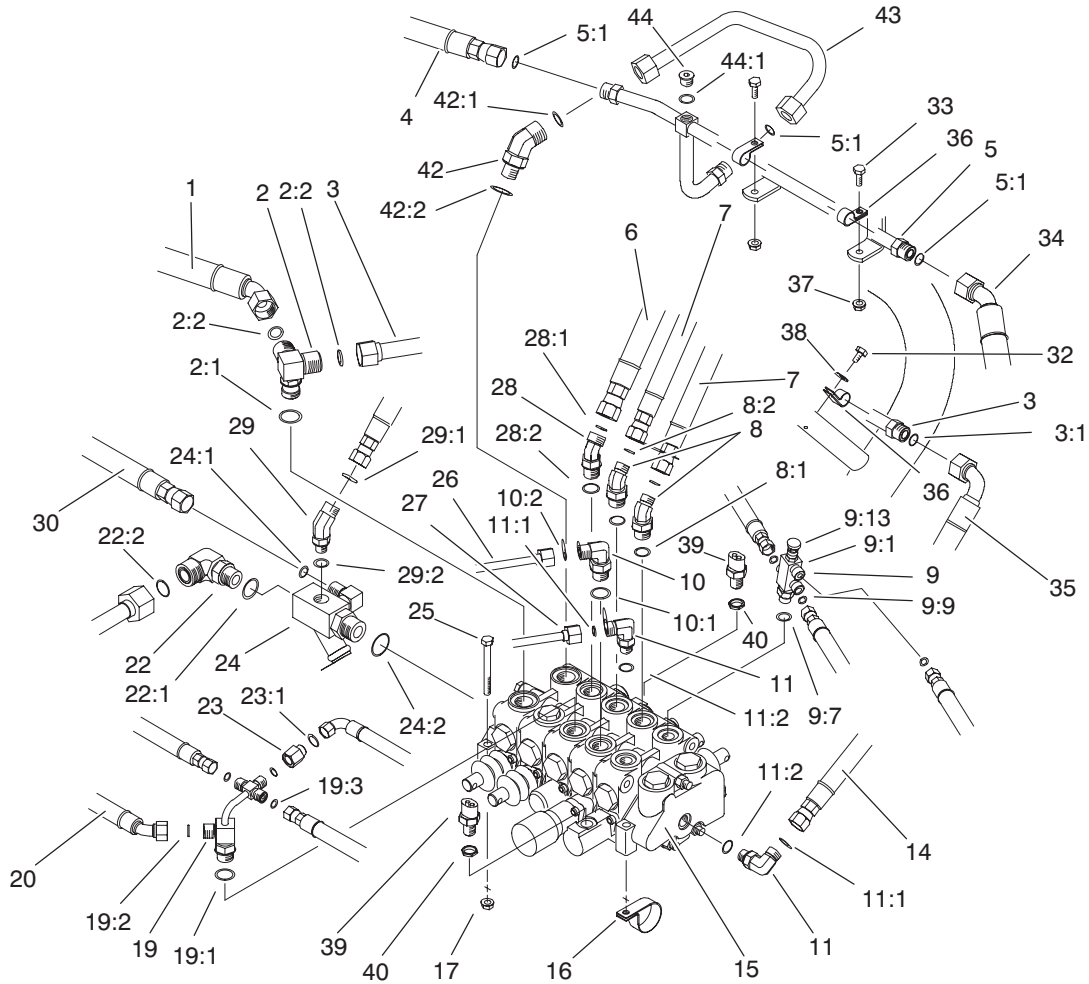

Sheet No.: 10

Control Valve Installation Assembly

Ref. No.	Part No.	Qty.	Description
1	98-0647	1	Hose-Hyd
2	63-4050	1	Fitting
2:1	237-80	1	O-Ring
2:2	237-65	2	O-Ring
3	70-7130	1	Line-Tube
3:1	237-65	2	O-Ring
4	98-2152	1	Hyd Hose ASM
5	93-0113	1	Tube-Traction
5:1	237-65	3	O-Ring
6	98-2151	1	Hose-Hyd
7	98-0649	2	Hose-Hyd
8	340-138	2	Fitting-Hyd, 45°
8:1	237-79	1	O-Ring
8:2	237-22	1	O-Ring
9	93-2556	1	Needle Valve ASM
9:1	93-2555	1	Fitting-Body
9:7	237-42	1	O-Ring
9:9	237-21	3	O-Ring
9:13	93-2554	1	Needle ASM
10	340-18	1	Fitting-Hyd, 90°
10:1	237-79	1	O-Ring
10:2	237-22	1	O-Ring
11	340-77	2	Fitting-Hyd, 90°
11:1	237-22	1	O-Ring
11:2	237-42	1	O-Ring
14	98-2150	1	Hose-Hyd

Ref. No.	Part No.	Qty.	Description
15	105-3800	1	Control Valve ASM
16	304-61	1	Clamp-Hose
17	32128-20	3	Nut-HF
19	83-1670	1	Fitting ASM
19:1	237-79	1	O-Ring
19:2	237-22	1	O-Ring
19:3	237-21	3	O-Ring
20	95-5986	1	Hose-Hyd
22	340-16	1	Fitting-Hyd, 90°
22:1	237-80	1	O-Ring
22:2	237-58	1	O-Ring
23	71-0990	1	Orifice
23:1	237-21	1	O-Ring
24	68-5260	1	Manifold-Tee
24:1	237-30	1	O-Ring
24:2	237-81	1	O-Ring
25	322-14	3	Screw-HH
26	63-4030	1	Tube-Hyd
27	63-4020	1	Tube-Hyd
28	340-101	1	Fitting-Hyd, 90°
28:1	237-30	1	O-Ring
28:2	237-79	1	O-Ring
29	340-137	1	Fitting
29:1	237-21	1	O-Ring
29:2	237-42	1	O-Ring
30	95-5987	1	Hose-Hyd

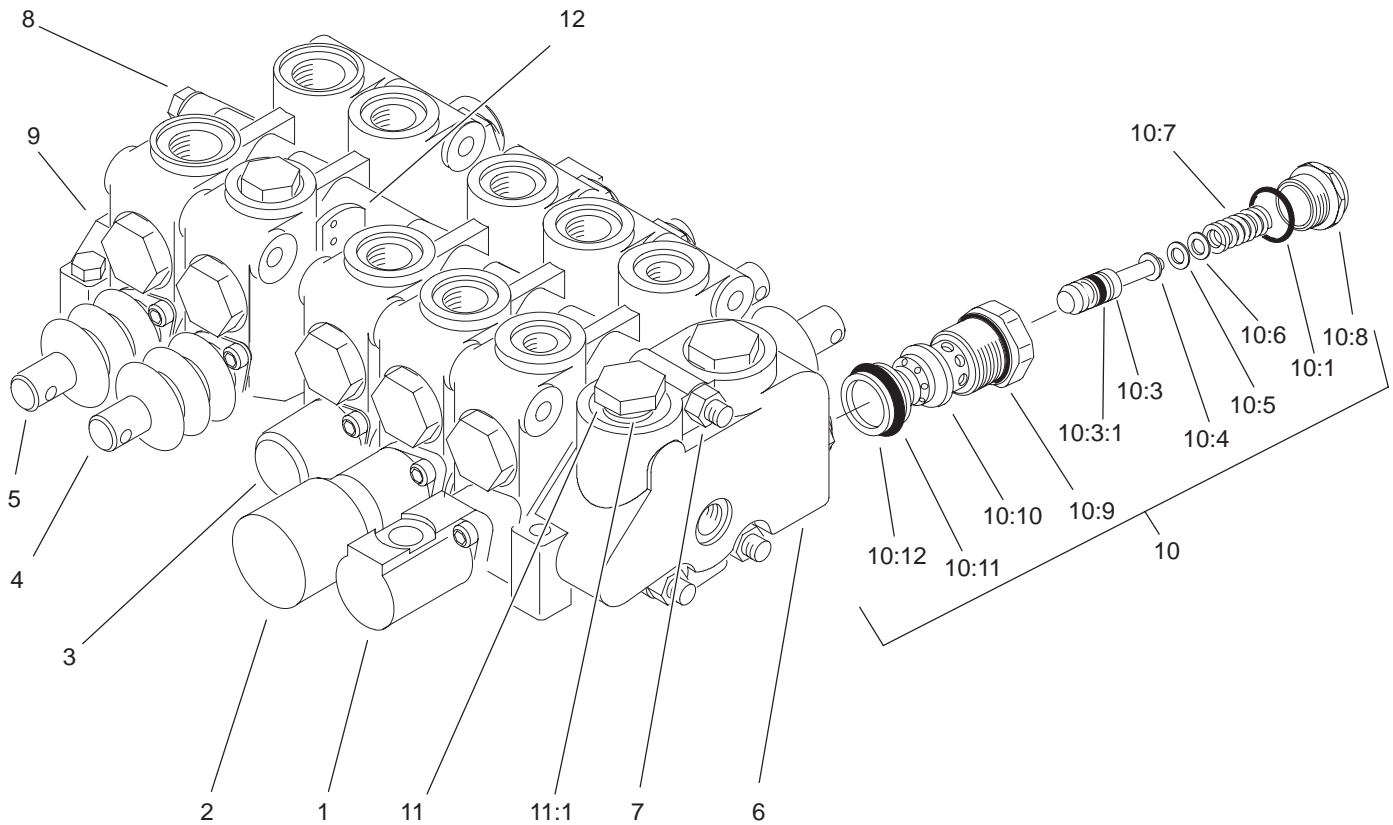

T-3794
Sheet No.:A5

Control Valve Assembly No. 105-3800

Ref. No.	Part No.	Qty.	Description
1	105-3801	1	Section 1 ASM
2	105-3802	1	Section 2 ASM
3	105-3803	1	Section 3 ASM
4	105-3804	1	Section 4 ASM
5	93-1386	1	Section 5 ASM
6	353-772	1	Cover-Left
7	3217-7	3	Nut-Hex
8	353-853	3	Bolt
9	353-668	1	Plate-Cover
10	353-766	1	Cart-Relief
10:1	237-54	1	O-Ring
10:3	353-531	1	Poppet & Ring ASM
10:3:1	353-392	1	Ring-Piston
10:4	353-328	1	Shim (.040)
10:5	353-329	1	Shim (.020)
10:6	353-330	1	Shim (.010)
10:7	353-855	1	Spring
10:8	353-334	1	Cap-Relief
10:9	353-331	1	O-Ring
10:10	353-760	1	Relief-Body
10:11	353-758	1	O-Ring
10:12	353-952	1	Seal-Back-Up
11	353-721	2	Plug
11:1	237-54	1	O-Ring
12	354-122	1	Disc-Seal

Ref. No.	Part No.	Qty.	Description
*13	92-2545	1	Spool Set Kit
*14	84-2190	1	Section Seal Kit

* Not illustrated

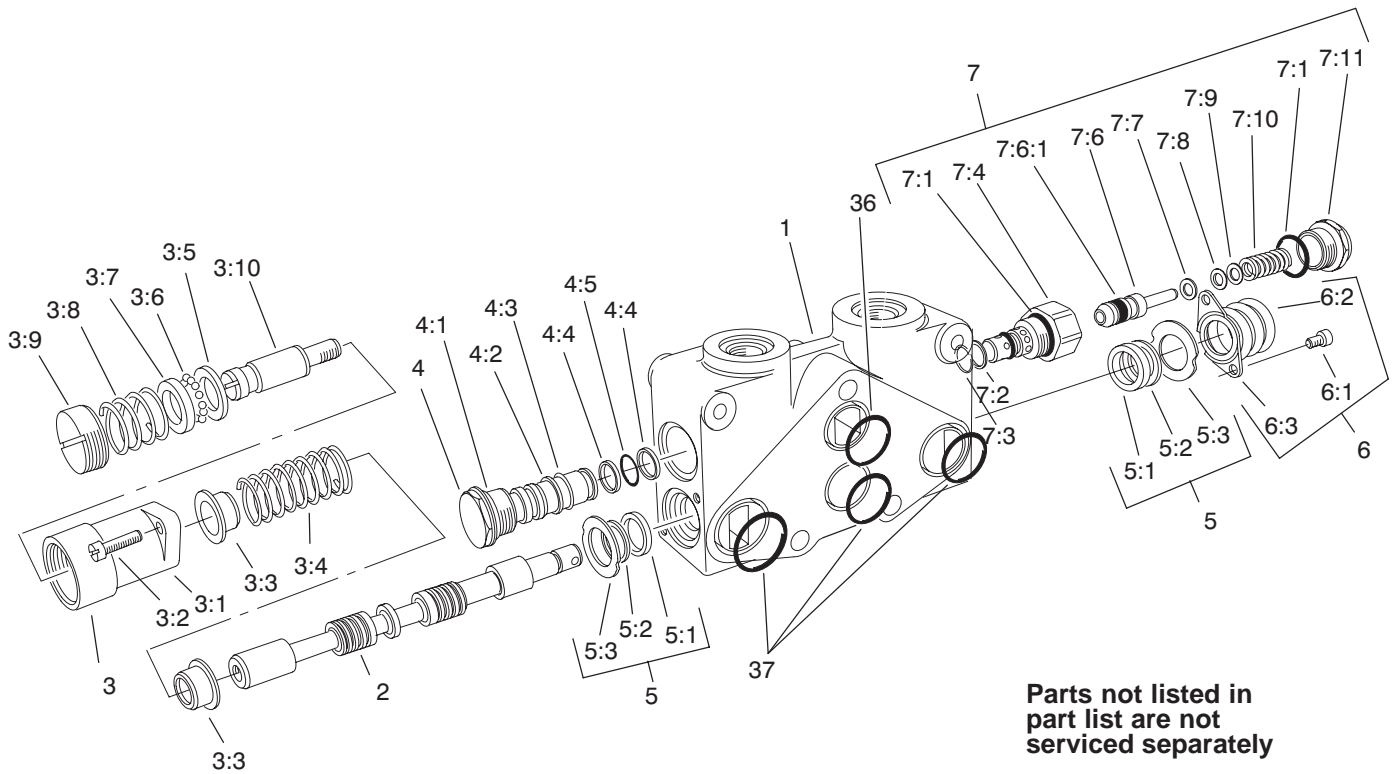

T-3778
Sheet No.:A7

Section 2 Assembly No. 105-3802

Ref. No.	Part No.	Qty.	Description
3	105-3806	1	Positioner
3:1	99-8181	1	Bonnet-R
3:2	3274-15	2	Screw-HSH
3:3	353-417	2	Collar-Stop
3:4	104-7741	1	Spring
3:5	354-29	1	Plate-Trust
3:6	52-5880	12	Ball-Detent
3:7	42-2680	1	Race-Ball
3:8	104-7727	1	Spring-Detent
3:9	353-763	1	Cap-Adjustment
3:10	353-762	1	Spud-Out
4	353-481	1	Lift Check ASM
4:1	237-54	1	O-Ring
4:2	353-306	1	Washer-Backup
4:3	353-305	1	O-Ring
4:4	353-303	2	Washer-Backup
4:5	353-302	1	O-Ring
5	92-2548	2	Kit-Set, Spool
5:1	353-957	1	Cup-Seal
5:2	92-2546	1	Wiper-Seal
5:3	92-2547	1	Seal-Retainer
6	93-3652	1	Boot-Dust
6:1	3274-52	2	Screw-HSH
6:2	353-575	1	Boot
6:3	93-3651	1	Retainer-Boot
7	353-642	1	Cartridge-Relief

Ref. No.	Part No.	Qty.	Description
7:1	237-54	2	O-Ring
7:2	353-306	1	Washer-Backup
7:3	353-305	1	O-Ring
7:4	353-851	1	Body-Relief
7:6	353-531	1	Poppet & Ring ASM
7:6:1	353-392	1	Ring-Piston
7:7	353-328	1	Shim (.040)
7:8	353-329	1	Shim (.020)
7:9	353-330	1	Shim (.010)
7:10	353-398	1	Spring
7:11	353-334	1	Cap-Relief

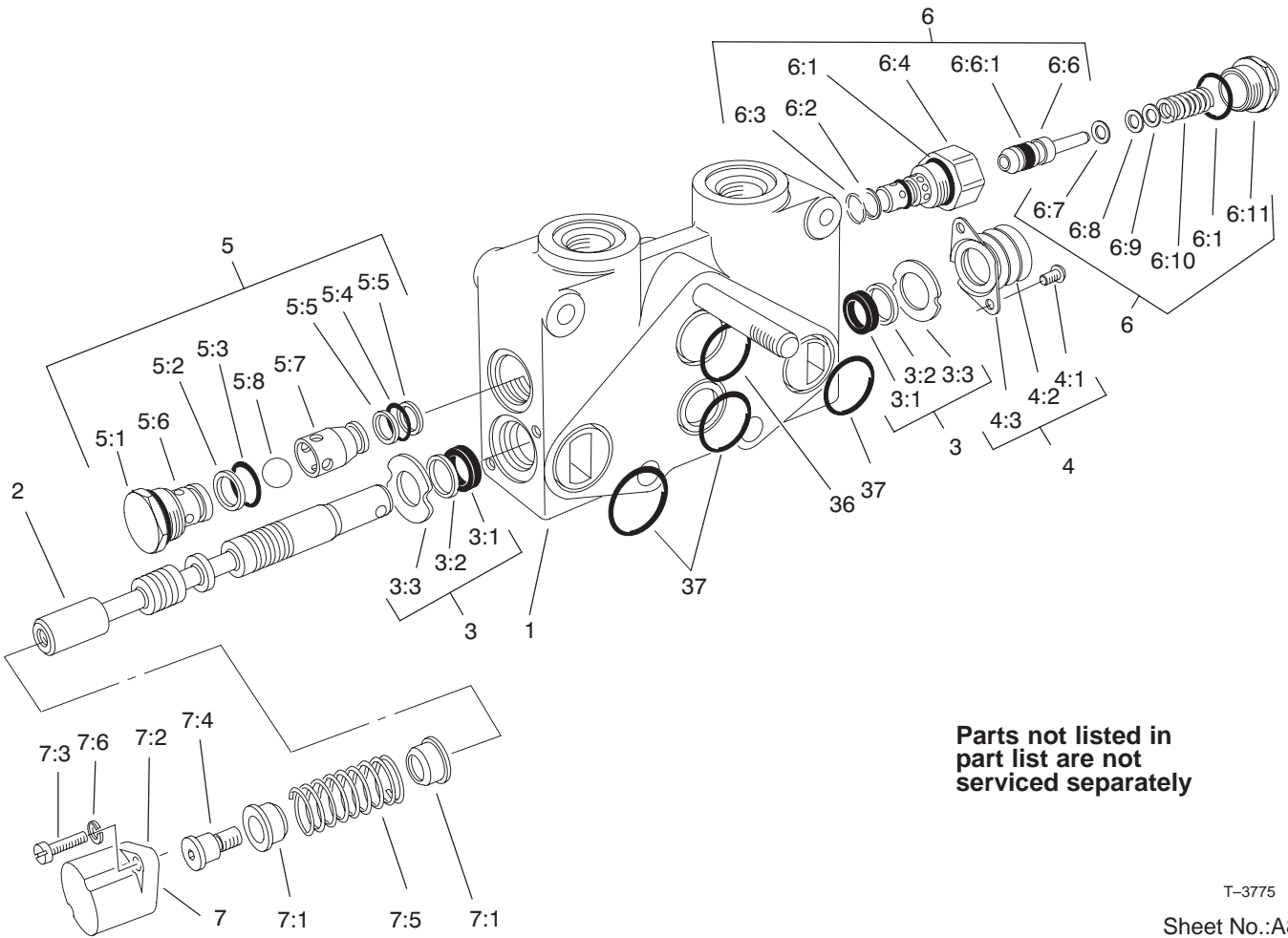

Parts not listed in part list are not serviced separately

T-3775

Sheet No.:A8

Section 3 Assembly No. 105-3803

Ref. No.	Part No.	Qty.	Description
3	92-2548	2	Kit-Set, Spool
3:1	353-957	1	Cup-Seal
3:2	92-2546	1	Wiper-Seal
3:3	92-2547	1	Seal-Retainer
4	93-3652	1	Boot-Dust
4:1	3274-52	2	Screw-HSH
4:2	353-575	1	Boot
4:3	93-3651	1	Retainer-Boot
5	354-129	1	Anticavitation Check ASM
5:1	237-54	1	O-Ring
5:2	353-306	1	Washer-Backup
5:3	353-305	1	O-Ring
5:4	353-302	1	O-Ring
5:5	353-303	2	Washer-Backup
5:6	353-483	1	Body-Check
5:7	353-484	1	Return-Ball, Check
5:8	353-737	1	Ball-Check
6	353-642	1	Cartridge-Relief
6:1	237-54	2	O-Ring
6:2	353-306	1	Washer-Backup
6:3	353-305	1	O-Ring
6:4	353-851	1	Body-Relief
6:6	353-531	1	Poppet & Ring ASM
6:6:1	353-392	1	Ring-Piston
6:7	353-328	1	Shim (.040)

Ref. No.	Part No.	Qty.	Description
6:8	353-329	1	Shim (.020)
6:9	353-330	1	Shim (.010)
6:10	353-398	1	Spring
6:11	353-334	1	Cap-Relief
7	105-3808	1	Positioner-Spring Return
7:1	353-417	2	Collar-Stop
7:2	99-6895	1	Bonnet
7:3	52-5900	2	Screw
7:4	52-5860	1	Collar-Spool
7:5	104-7741	1	Spring
7:6	3253-3	2	Washer-Lock

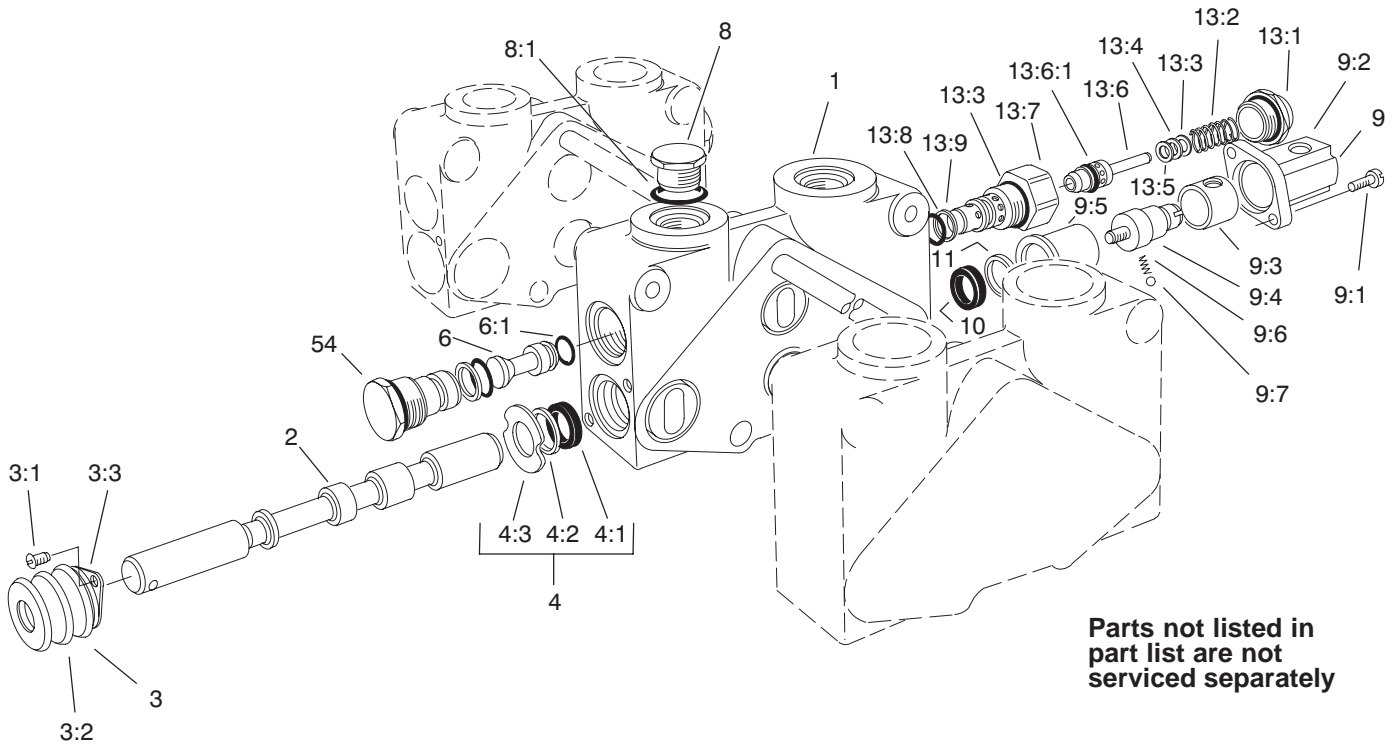

T-3776
Sheet No.:A9

Section 4 Assembly No. 105-3804

Ref. No.	Part No.	Qty.	Description
3	93-3652	1	Boot-Dust
3:1	3274-52	2	Screw-HSH
3:2	353-575	1	Boot
3:3	93-3651	1	Retainer-Boot
4	92-2548	1	Kit-Set, Spool
4:1	353-957	1	Cup-Seal
4:2	92-2546	1	Wiper-Seal
4:3	92-2547	1	Seal-Retainer
6	353-844	1	Plug
6:1	353-850	1	O-Ring
8	353-550	1	Plug-Hyd
8:1	237-79	1	O-Ring
9	353-840	1	Bonnet ASM
9:1	52-5900	2	Screw
9:2	353-847	1	Bonnet
9:3	353-849	1	Sleeve
9:4	353-846	1	Spud
9:5	353-845	1	Sleeve-Detent
9:6	353-730	1	Spring
9:7	353-731	1	Ball
10	353-957	1	Cup-Seal
11	353-958	1	Washer
13	354-140	1	Relief-Rcm
13:1	353-334	1	Cap-Relief
13:2	353-398	1	Spring
13:3	353-330	1	Shim (.010)

Ref. No.	Part No.	Qty.	Description
13:4	353-329	1	Shim (.020)
13:5	353-328	1	Shim (.040)
13:6	353-531	1	Poppet & Ring ASM
13:6:1	353-392	1	Ring-Piston
13:7	353-851	1	Body-Relief
13:8	353-305	1	O-Ring
13:9	353-306	1	Washer-Backup
13:10	237-54	2	O-Ring
14	353-953	1	Plug ASM

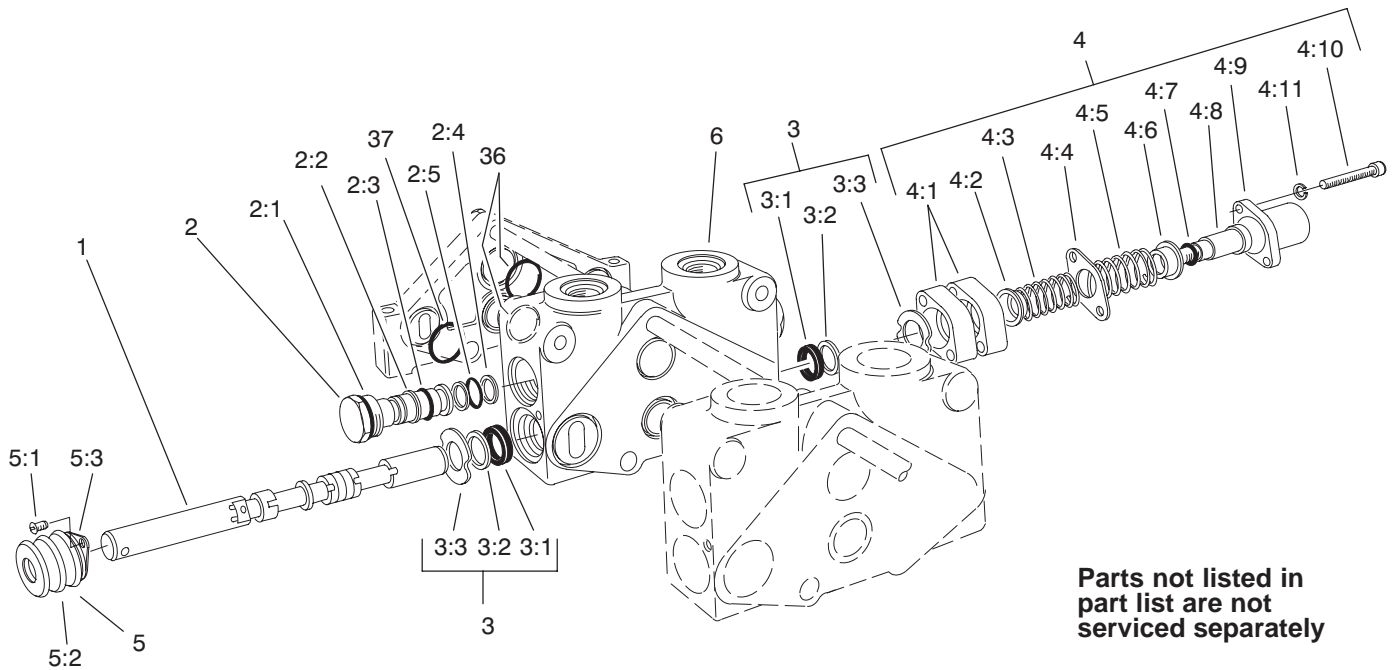

T-3779
Sheet No.:B1

Section 5 Assembly No. 93-1386

Ref. No.	Part No.	Qty.	Description
1	94-5434	1	Spool
2	353-481	2	Lift Check ASM
2:1	237-54	1	O-Ring
2:2	353-306	1	Washer-Backup
2:3	353-305	1	O-Ring
2:4	353-303	2	Washer-Backup
2:5	353-302	1	O-Ring
3	92-2548	2	Kit-Set, Spool
3:1	353-957	1	Cup-Seal
3:2	92-2546	1	Wiper-Seal
3:3	92-2547	1	Seal-Retainer
4	353-833	1	Positioner ASM
4:1	353-733	2	Spacer-Bonnet
4:2	353-417	1	Collar-Stop
4:3	353-831	1	Spring
4:4	353-529	1	Plate-Retainer, Seal
4:5	92-3148	1	Spring-Traction
4:6	353-808	1	Collar-Spring
4:7	353-830	1	O-Ring
4:8	94-4248	1	Collar-Spool
4:9	99-6895	1	Bonnet
4:10	354-28	2	Screw-HS
4:11	3253-4	2	Washer-Lock
5	93-3652	1	Boot-Dust
5:1	3274-52	2	Screw-HSH

Ref. No.	Part No.	Qty.	Description
5:2	353-575	1	Boot
5:3	93-3651	1	Retainer-Boot

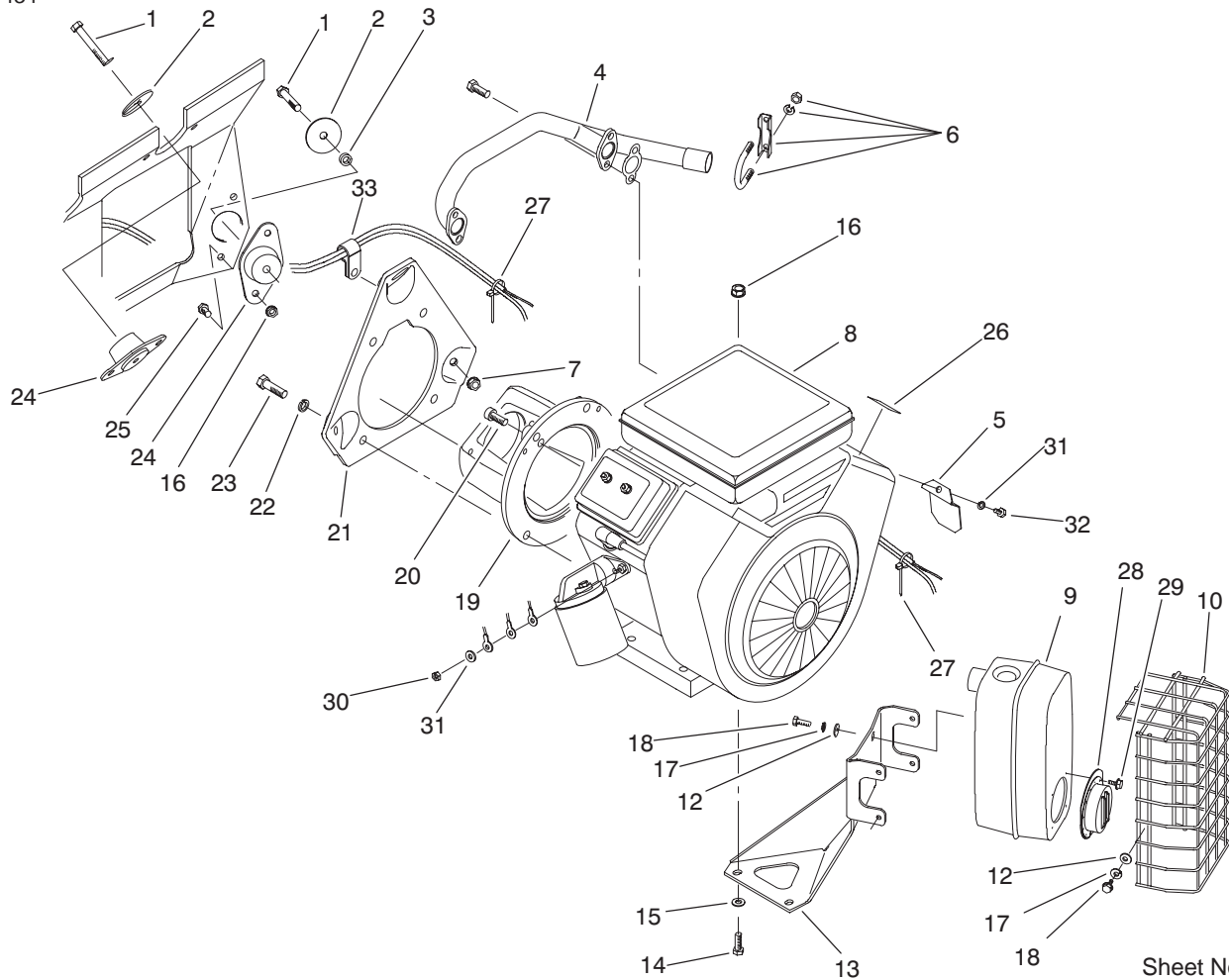

Sheet No.: 11

Engine Installation Assembly

Ref. No.	Part No.	Qty.	Description
1	323-12	3	Screw-HH
2	83-1040	3	Washer-Flat
3	83-1050	2	Spacer
4	83-1080	1	Exhaust Manifold ASM
5	83-2310	1	Shield-Regulator
6	2112-11	1	Clamp-Muffler
7	3290-357	3	Nut-Flange, Lock
8	100-6438	1	Engine-B & S, 350447-1259-E1
9	98-0616	1	Muffler ASM
10	83-1400-03	1	Shield-Muffler
12	3256-1	8	Washer-Flat
13	83-1630-03	1	Bracket-Support, Muffler
14	322-8	2	Screw-HH
15	3256-23	2	Washer-Flat
16	32128-20	8	Nut-HF
17	3253-3	8	Washer-Lock
18	49-2040	8	Screw-Tapping
19	83-1060-03	1	Adapter-Pump
20	3274-7	2	Screw-HSH
21	85-8120-03	1	Plate-Mount, Engine
22	3253-6	4	Washer-Lock
23	324-7	4	Screw-HH
24	83-1030	3	Mount-Engine
25	322-3	6	Screw-HH

Ref. No.	Part No.	Qty.	Description
26	93-8069	1	Decal-Surface, Hot
27	3290-379	2	Tie-Cable
28	83-2220	1	Deflector-Exhaust
29	83-2230	4	Screw-HH
30	43-2830	1	Nut-Hex
31	43-5930	2	Washer-Spring
32	33113-016	1	Screw-HH
33	2412-81	1	Clamp

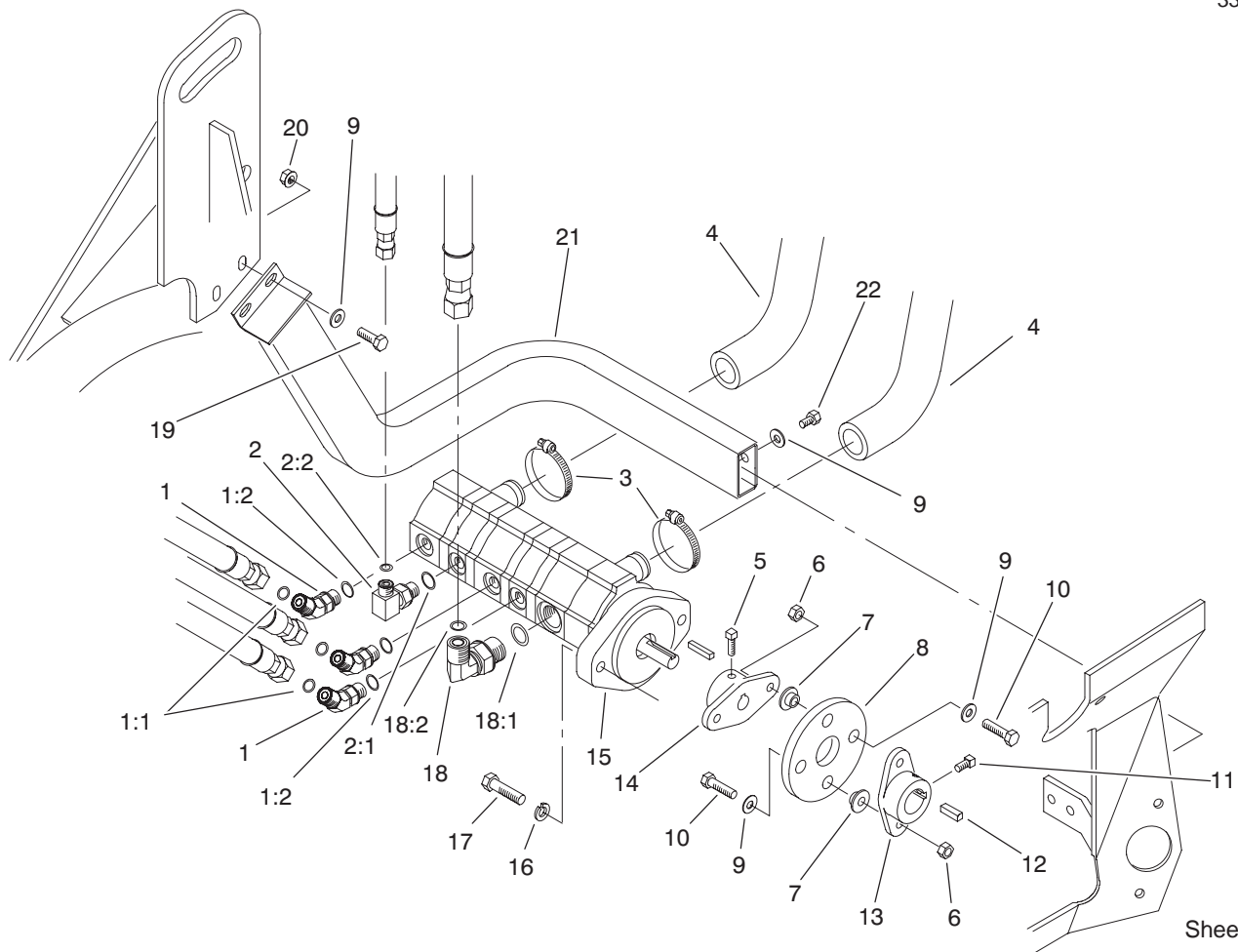

Sheet No.: 12

Hydraulic Pump Installation Assembly

Ref. No.	Part No.	Qty.	Description
1	340-87	3	Fitting-Adapter, 45°
1:1	237-22	1	O-Ring
1:2	237-42	1	O-Ring
2	340-82	1	Adapter
2:1	237-42	1	O-Ring
2:2	237-21	1	O-Ring
3	2412-34	2	Clamp-Hose
4	83-0910	2	Hose-Inlet, Pump
5	3241-6	2	Screw-SQH
6	3296-29	4	Nut-Lock NI
7	27-6600	4	Spacer-Coupling
8	44-2230	1	Coupling-Rubber
9	3256-23	8	Washer-Flat
10	322-6	4	Screw-HH
11	3241-2	2	Screw-SQH
12	10-7070	1	Key-Square
13	27-1960	1	Hub-Engine
14	27-1970	1	Hub-Pump
15	92-9764	1	Hyd Pump ASM
16	3253-21	2	Washer-Lock
17	323-8	2	Screw-HH
18	340-105	1	Fitting-90°
18:1	237-80	1	O-Ring
18:2	237-30	1	O-Ring
19	322-4	2	Screw-HH
20	32128-20	2	Nut-HF

Ref. No.	Part No.	Qty.	Description
21	83-1940-01	1	Guard-Pump
22	322-1	2	Screw-HH

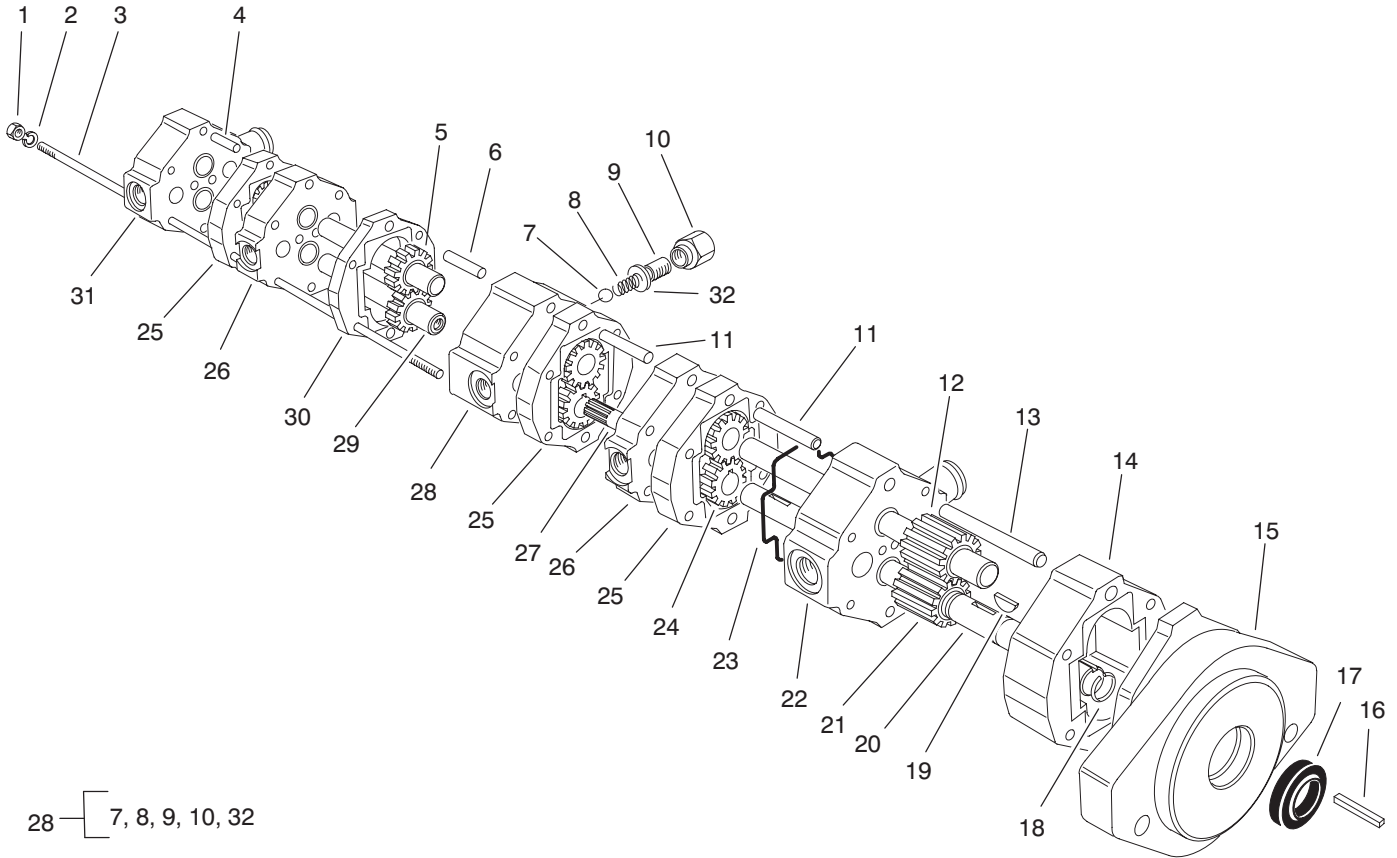

28 — [7, 8, 9, 10, 32

Parts not listed in partslist are not serviced seperately.

Sheet No.: B2
T-0645

Hydraulic Pump Assembly No. 92-9764

Ref. No.	Part No.	Qty.	Description
1	3217-6	4	Nut-Hex
2	354-16	4	Washer
3	354-17	4	Stud
4	354-11	2	Dowel
5	354-9	1	Idler Shaft & Gear ASM
6	354-12	2	Dowel
11	354-13	4	Dowel
12	92-9774	1	Shaft
13	354-14	2	Pin-Dowel
14	92-9766	1	Plate-Gear
15	354-2	1	Body ASM
16	5-0946	1	Key-Square
17	353-931	1	Oil Seal
18	353-886	2	Ring-Retaining
19	353-884	4	Key
20	92-9772	1	Shaft-Drive
21	92-9773	1	Gear-59b
22	354-3	1	Bearing Plate ASM
23	353-922	10	Ring-Seal
24	353-967	6	Gear
25	353-969	3	Plate-Gear
26	353-923	2	Plate
27	354-5	1	Adaptor-Splined
28	354-4	1	Bearing Plate ASM
29	354-8	1	Drive Shaft & Gear

Ref. No.	Part No.	Qty.	Description
30	354-6	1	Plate-Gear
31	354-7	1	Pump Cover ASM
32	354-35	1	Gasket

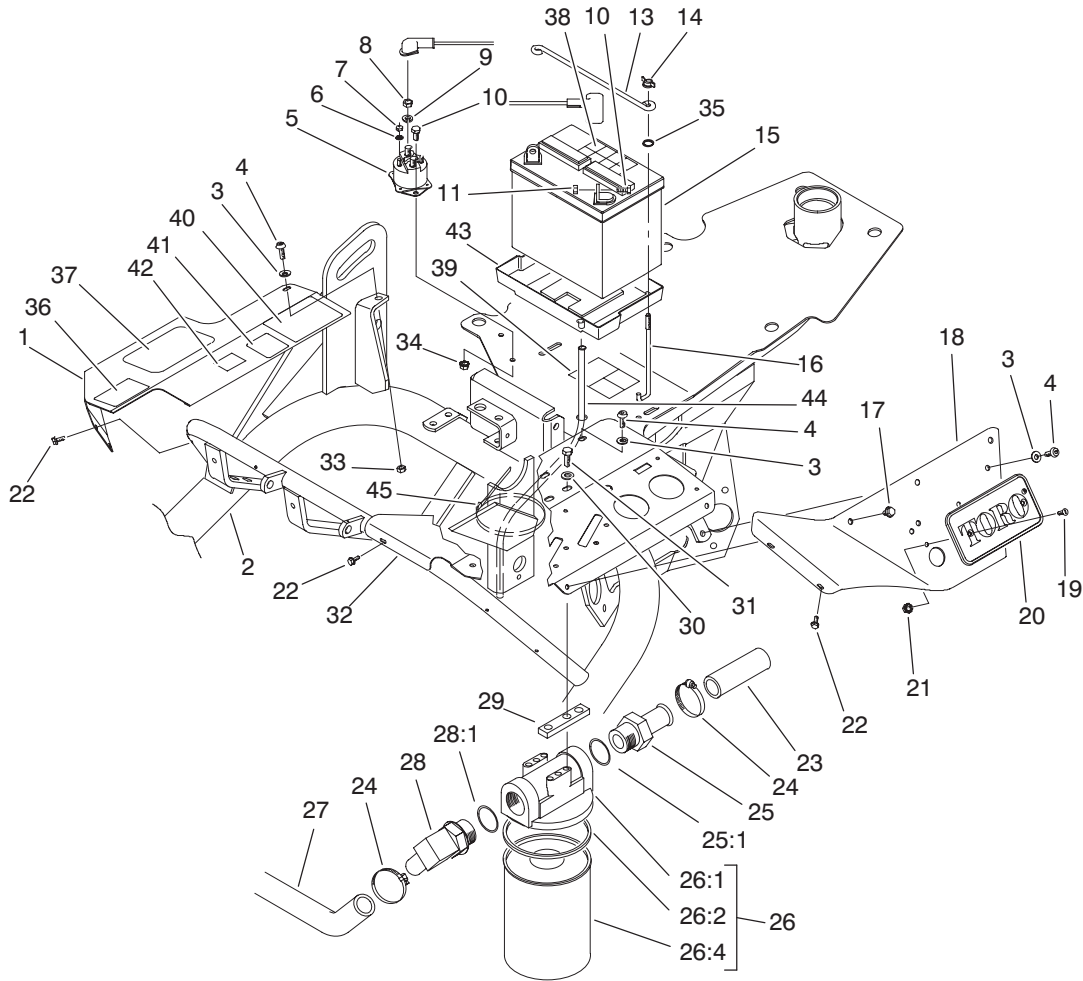

Sheet No.: 13

Frame Assembly

Ref. No.	Part No.	Qty.	Description
1	94-2694-01	1	Cover-RH
2	92-9164-01	1	Frame ASM
3	3256-22	3	Washer-Flat
4	3274-69	3	Screw-HSBH
5	28-4210	1	Solenoid
6	3254-1	2	Washer-Lock, Internal
7	3219-14	2	Nut-Hex
8	3218-13	2	Nut-Jam
9	3253-4	2	Washer-Lock
10	321-3	4	Screw-HH
11	3217-5	2	Nut-Hex
13	100-6434	1	Hold Down-Battery
14	32103-22	2	Nut-Wing
15	92-1677	1	Battery-Dry
16	100-6435	2	Post-Battery
17	46-8560	3	Screw-HHF
18	83-0840-01	1	Shield-Cover, Valve
19	3290-470	2	Screw-HSFH
20	61-3310	1	Plate-Logo
21	32149-7	2	Nut-Keps
22	32104-116	5	Screw
23	83-1430	1	Hose-Line, Return
24	2412-34	3	Clamp-Hose
25	353-563	1	Fitting-Hyd, Straight
25:1	237-101	1	O-Ring
☆26		1	Filter & Head ASM

Ref. No.	Part No.	Qty.	Description
26:1	44-5560	1	Head-Filter, Oil
26:2	72-3850	1	Seal-Filter, Oil
26:4	74-3570	1	Filter
27	68-5880	1	Hose-Hyd
28	353-564	1	Fitting-90°
28:1	237-101	1	O-Ring
29	27-2380	2	Spacer
30	3256-23	4	Washer-Flat
31	322-4	4	Screw-HH
32	83-0830-01	1	Panel-Control, Upper
33	3296-16	3	Nut-Lock, NI
34	32149-2	2	Nut
35	237-143	2	O-Ring
36	93-8065	1	Decal-Traction
37	67-1300	1	Decal-Toro
38	93-7276	1	Decal-Danger
39	93-6668	1	Decal-Battery
40	92-5524	1	Decal-Rating, Noise
41	63-9920	1	Decal-Level, Noise
42	93-7252	1	Decal-International
43	106948	1	Tray-Battery
44	104-2061	1	Tube-Drain, Battery
45	3290-379	1	Tie-Cable

☆ Not serviced

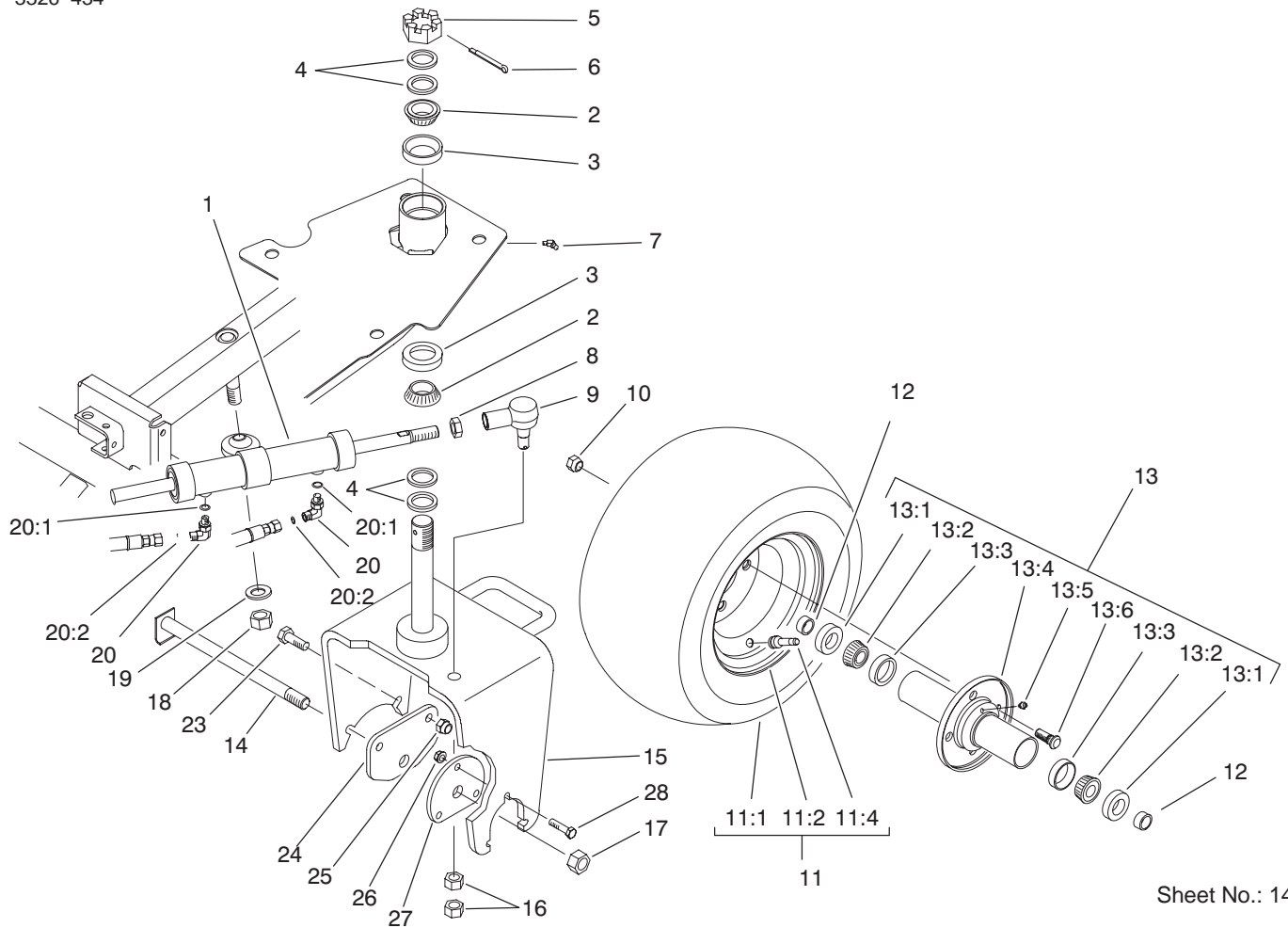

Sheet No.: 14

Rear Wheel Assembly

Ref. No.	Part No.	Qty.	Description
1	83-2330	1	Cylinder-Steering
2	254-70	2	Bearing-Cone
3	254-61	2	Bearing-Cup
4	18-6320	4	Washer-Steering
5	32136-9	1	Nut-Hex, Slot
6	3272-37	1	Pin-Cotter
7	302-11	1	Fitting-Lube 45°
8	84-5300	1	Nut-Jam
9	83-1640-03	1	Rod End ASM
10	242-50	4	Nut-Lug
☆11		1	Wheel & Tire ASM
11:1	28-3680	1	Tire
11:2	217-60	1	Rim
11:4	232-24	1	Stem-Valve
*11:5	232-37	1	Tube
12	74-3730	2	Spacer-Spindle, Rear
☆13		1	Hub-Tire, Sulky
13:1	253-111	2	Seal-Oil
13:2	254-78	2	Bearing-Cone
13:3	254-79	2	Bearing-Roller, Cup
13:4	75-9440	1	Hub ASM
13:5	302-55	1	Zerk
13:6	10-6830	4	Stud-Type, Drive
14	5-3934	1	Bolt-Caster
15	93-2529-01	1	Fork-Castor
16	3220-6	2	Nut-Jam

Ref. No.	Part No.	Qty.	Description
17	3296-67	1	Nut-Lock NI
18	3217-12	1	Nut-Hex
19	3256-28	1	Washer-Flat
20	340-132	2	Fitting-Hyd, 90°
20:1	237-78	1	O-Ring
20:2	237-21	1	O-Ring
23	325-6	2	Screw-HH
24	99-1485-01	1	Plate-Adapter, Motor
25	3296-23	2	Nut-Lock, NI
26	3296-39	3	Nut-Lock, NI
27	99-1486-01	1	Plate-Adapter
28	323-8	3	Screw-HH

☆ Not serviced
* Not illustrated

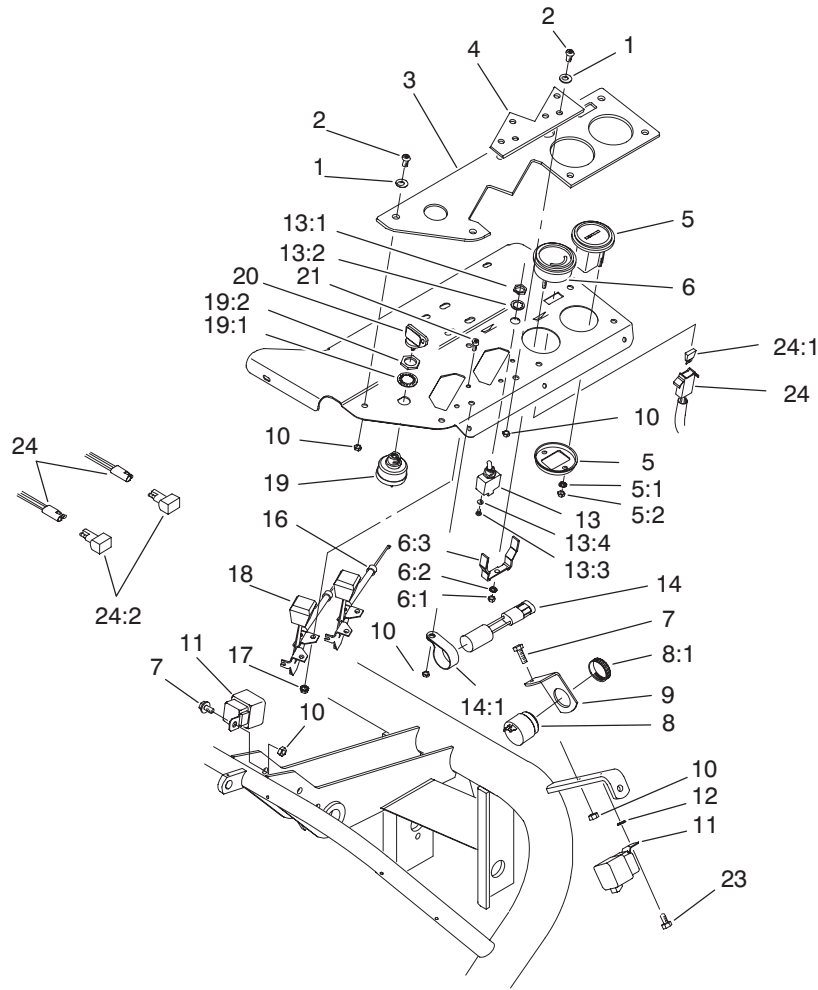

Sheet No.: 15

Control Panel Assembly

Ref. No.	Part No.	Qty.	Description
1	3256-1	8	Washer-Flat
2	3274-69	8	Screw-HSBH
3	93-8061	1	Panel-Control
4	83-2030	1	Plate-Filler
5	66-2950	1	Gauge-Hourmeter
5:1	3255-20	2	Washer-Lock
5:2	3217-25	2	Nut-Hex
6	98-2160	1	Voltmeter
6:1	3217-27	1	Nut-Hex
6:2	3255-25	1	Washer-Lock
6:3	78-0080	1	Clamp-Mounting
7	321-4	2	Screw-HH
8	80-9330	1	Alarm-Audio
8:1	104-5107	1	Nut-Plastic, Knurled
9	83-1530	1	Bracket-Support, Buzzer
10	3296-16	10	Nut-Lock, NI
11	70-1480	2	Relay
12	3255-7	1	Washer-Lock/Ext
13	83-1660	1	Switch - 3 Position
13:1	218-498	2	Locknut-Hex
13:2	218-589	1	Washer
13:3	218-588	3	Screw
13:4	3253-19	3	Washer-Lock/Sp
14	83-2280	1	Timer-Delay
14:1	98-4604	1	R-Clamp

Ref. No.	Part No.	Qty.	Description
16	83-0040	1	Control-Choke
17	3296-27	4	Nut-Lock NI
18	83-0030	1	Control-Throttle
19	88-9830	1	Switch-Ignition
19:1	3254-5	1	Washer-Lock, Internal
19:2	218-461	1	Nut-HH
20	63-8360	2	Key-Ignition
21	3273-26	4	Screw-HSH
23	32104-95	1	Screw-HWH
24	104-2058	1	Harness-Wire, Main
24:1	218-578	1	Fuse-10 Amp
24:2	100-4918	2	Diode

☆ Not serviced

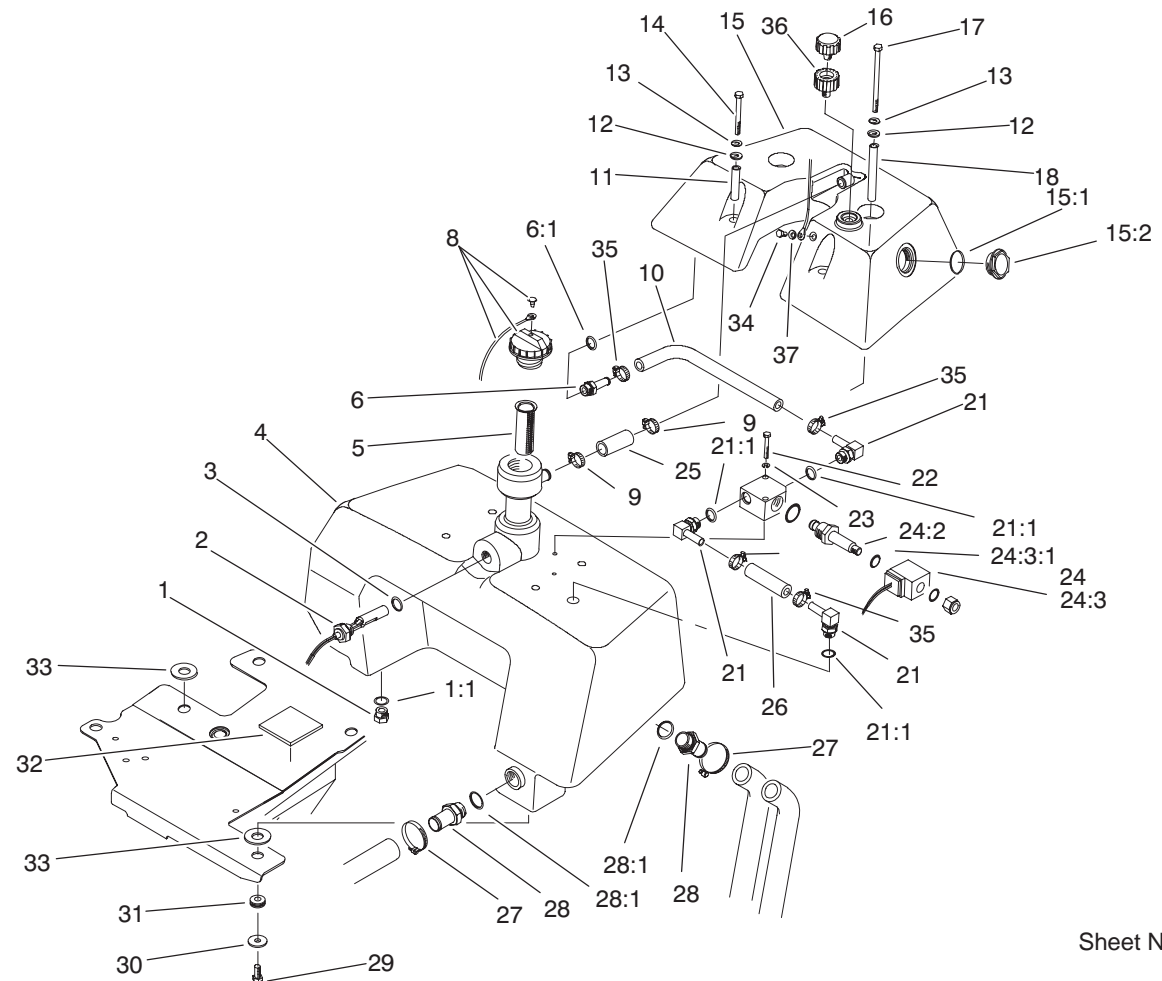

Sheet No.: 16

Hydraulic Reservoir Assembly

Ref. No.	Part No.	Qty.	Description
1	353-550	1	Plug-Hyd
1:1	237-79	1	O-Ring
2	83-1450	1	Sensor-Level, Oil
3	237-80	1	O-Ring
4	92-8966	1	Tank-Hyd
5	83-1520	1	Screen-Filler
6	354-121	1	Fitting-Hyd, Straight
6:1	237-79	1	O-Ring
8	93-7160	1	Cap-Oil, Hyd
9	2412-141	2	Clamp-Drive, Worm
10	83-2070	1	Hose-Valve
11	83-1550	2	Spacer-Tube, Short
12	83-1470	4	Washer-Neoprene
13	3256-71	4	Washer-Flat
14	322-14	2	Screw-HH
15	83-2100	1	Tank-Auxiliary, Hyd
15:1	94-8166	1	O-Ring
15:2	83-2250	1	Guage-Sight
16	68-6150	1	Breather-Air
17	322-29	2	Screw-HH
18	83-1560	2	Spacer-Tube, Long
21	354-120	3	Fitting-Hyd, 90°
21:1	237-79	2	O-Ring
22	321-11	2	Screw-HH
23	3253-3	2	Washer-Lock
24	83-1460	1	Solenoid Valve ASM

Ref. No.	Part No.	Qty.	Description
24:2	83-2000	1	Spool-Valve
24:3	83-2010	1	Coil-Valve
24:3:1	94-5438	1	Seal-Solenoid
25	83-2090	1	Hose-Overflow
26	83-2080	1	Hose-Valve, Tank
27	2412-34	3	Clamp-Hose
28	83-0870	3	Fitting-Barb, Hose
28:1	237-177	1	O-Ring
29	323-6	3	Screw-HH
30	63-8410	3	Washer
31	240-11	3	Grommet-Mount, Tank
32	83-2390	1	Pad-Tank
33	83-2400	2	Spacer/Washer-Tank
34	321-2	1	Screw-HH
35	2412-36	4	Clamp-Hose
36	92-8020	1	Adapter-Breather
37	3256-22	1	Washer-Flat

Hydraulic Schematic

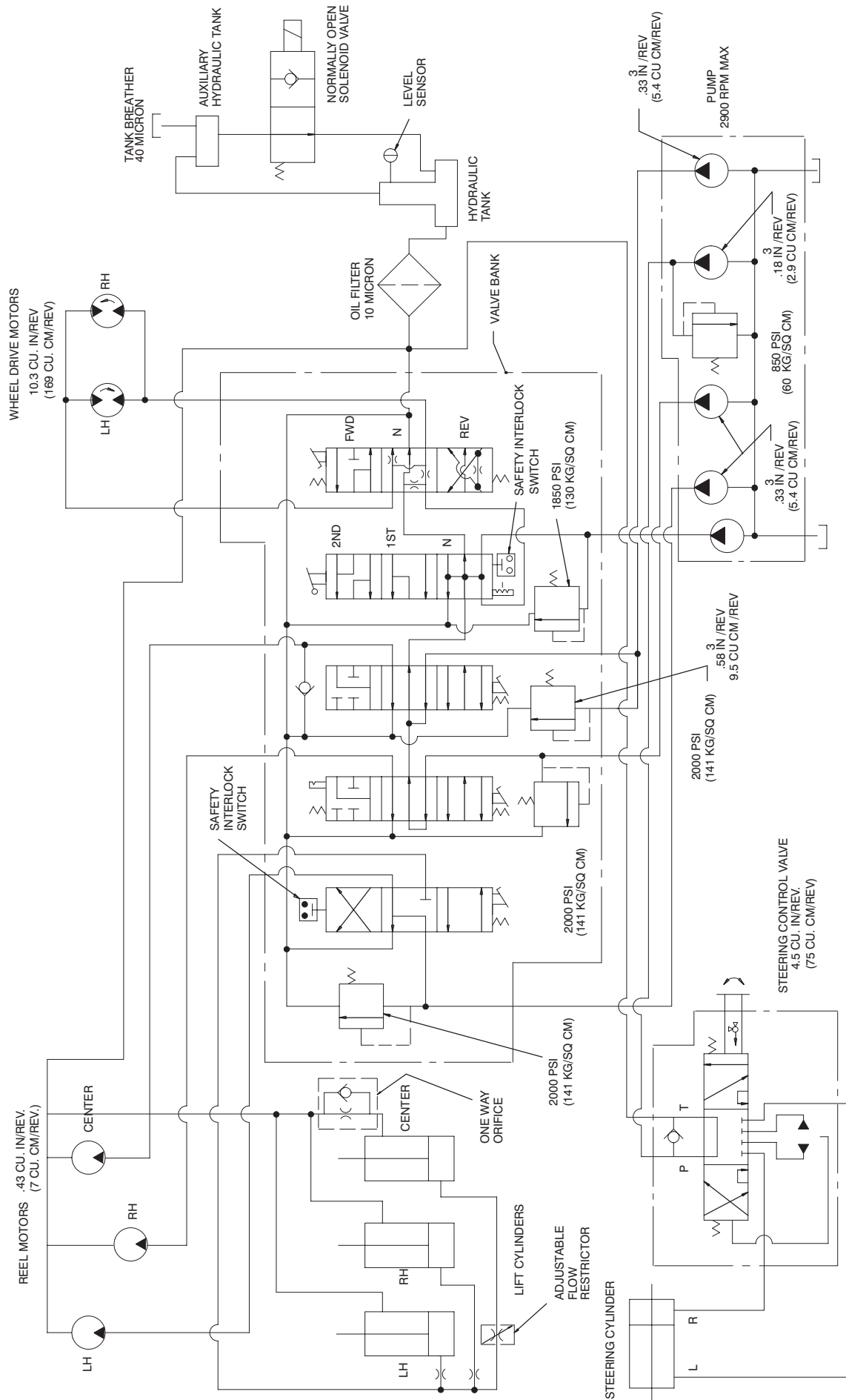

1019 LABEL KIT

1058 OWNER'S MANUAL

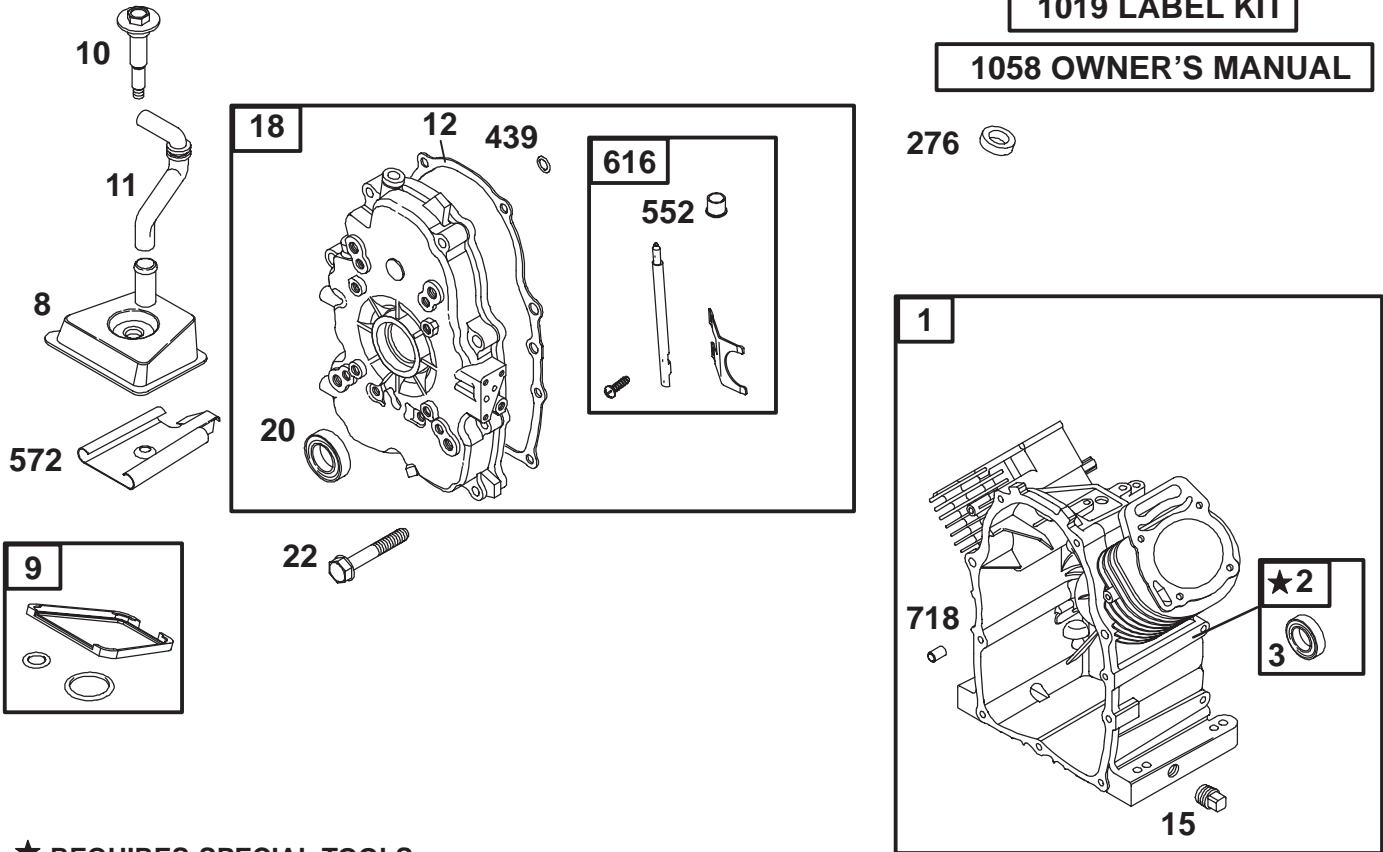

★ REQUIRES SPECIAL TOOLS TO INSTALL. SEE REPAIR INSTRUCTION MANUAL.

Assemblies include all parts shown in frames.

Cylinder Assembly Briggs and Stratton Model 350447-1259-E1

Ref. No.	Part No.	Qty.	Description
1	692544	1	Cylinder Assembly
2	808534	1	Bearing/Seal Kit
★3	805101	1	Oil Seal
8	692095	1	Breather Assembly
△★9	807688	1	Valve Cover Gasket
10	690751	1	Screw (Breather Assembly)
11	806083	1	Breather Tube
★12	691684	1	Crankcase Gasket
15	690946	1	Oil Drain Plug
18	808847	1	Crankcase Cover
★20	805049	1	Oil Seal
22	692540	1	Screw (Crankcase Gasket)
276	690704	1	Sealing Washer
★439	692154	1	O Ring Seal (Crankcase Cover)
552	806686	1	Governor Crank Bushing
572	690686	1	Breather Baffle
616	806685	1	Governor Crank
718	806469	1	Locating Pin

Ref. No.	Part No.	Qty.	Description
1019	808036	1	Label Kit
1058	274272	1	Owner's Manual

△ Included in Valve Overhaul Gasket Set—Ref. 1095.

★ Included in Engine Gasket Set—Ref. 358.

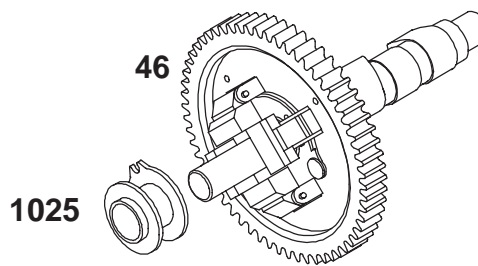
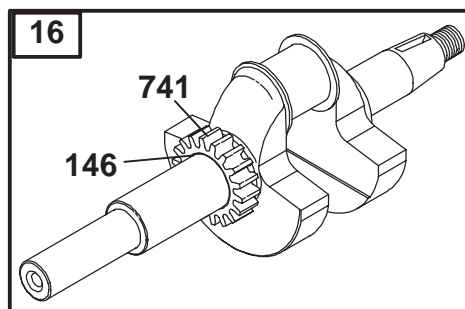
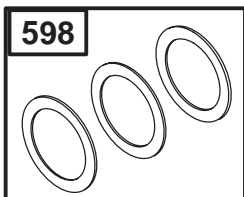
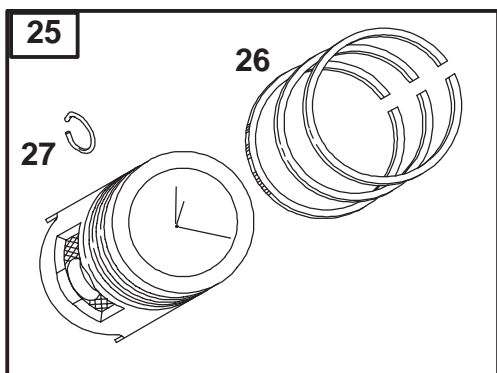
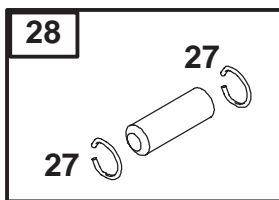
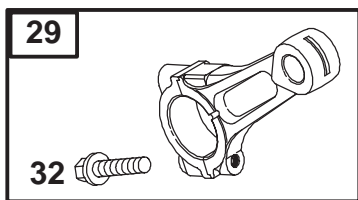

Assemblies include all parts shown in frames.

Crankshaft Assembly Briggs and Stratton Model 350447-1259-E1

Ref. No.	Part No.	Qty.	Description
16	692171	1	Crankshaft
17	690752	1	Ball Bearing
25	808326	1	Piston Assembly (Standard)
	808336	1	Piston Assembly (.010 O.S.)
	808337	1	Piston Assembly (.020 O.S.)
	808338	1	Piston Assembly (.030 O.S.)
26	807889	1	Ring Set (Standard)
	807994	1	Ring Set (.010 O.S.)
	807995	1	Ring Set (.020 O.S.)
	807996	1	Ring Set (.030 O.S.)
27	690683	1	Piston Pin Lock
28	807886	1	Piston Pin (Standard)
29	807900	1	Connecting Rod (Standard)
	807803	1	Connecting Rod (.020 Undersize)
32	690698	1	Screw (Connecting Rod 1 7/8")

Ref. No.	Part No.	Qty.	Description
46	691557	1	Camshaft
146	691639	1	Timing Key
377	808095	1	Woodruff Key
598	807625	1	End Play Shim
741	691530	1	Timing Gear
1025	690689	1	Governor Spool

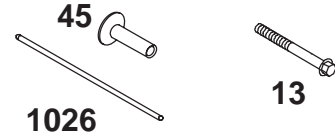
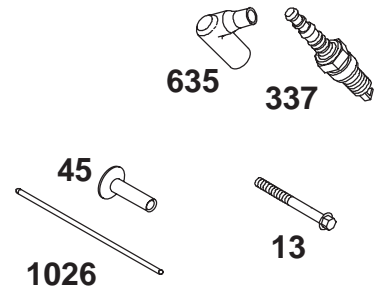
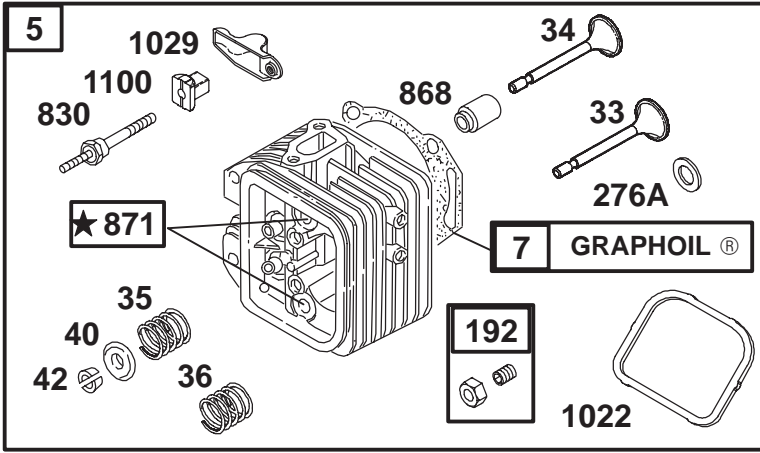

★ REQUIRES SPECIAL TOOLS TO INSTALL. SEE REPAIR INSTRUCTION MANUAL.

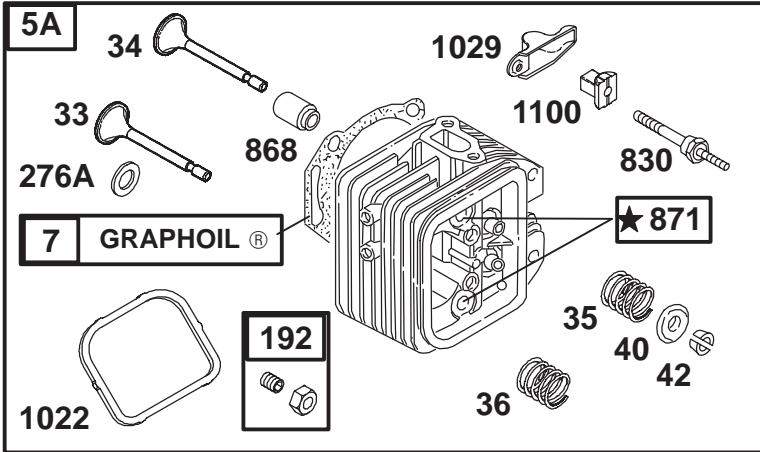

Assemblies include all parts shown in frames.

Cylinder Head Assembly Briggs and Stratton Model 350447-1259-E1

Ref. No.	Part No.	Qty.	Description
5	808383	1	Cylinder Head (No. 1)
5A	808384	1	Cylinder Head (No. 2)
Δ★7	690888	1	Cylinder Head Gasket
13	692059	1	Screw (Cylinder Head)
33	807681	1	Exhaust Valve
34	807680	1	Intake Valve
35	692084	1	Valve Spring (Intake)
36	692084	1	Valve Spring (Exhaust)
40	692058	1	Valve Retainer
42	807683	1	Valve Retainer
45	690977	1	Valve Tappet
192	807623	1	Rocker Arm Adjuster
Δ★276A	691766	1	Sealing Washer
337	496018	1	Sparkplug
383	19374	1	Sparkplug Wrench
613	691902	1	Screw (Exhaust Manifold)
635	692076	1	Sparkplug Boot
830	691544	1	Stud (Rocker Arm)

Ref. No.	Part No.	Qty.	Description
868	691963	1	Valve Seal
871	692057	1	Bushing Guide
883	691613	1	Exhaust Gasket
Δ★1022	806039	1	Rocker Cover Gasket
1026	691836	1	Push Rod (Steel-Intake)
	691758	1	Push Rod (Aluminum-Exhaust)
1029	691543	1	Rocker Arm
1100	690973	1	Rocker Arm Pivot

Δ Included in Valve Overhaul Gasket Set-Ref. 1095.

★ Included in Engine Gasket Set-Ref. 358.

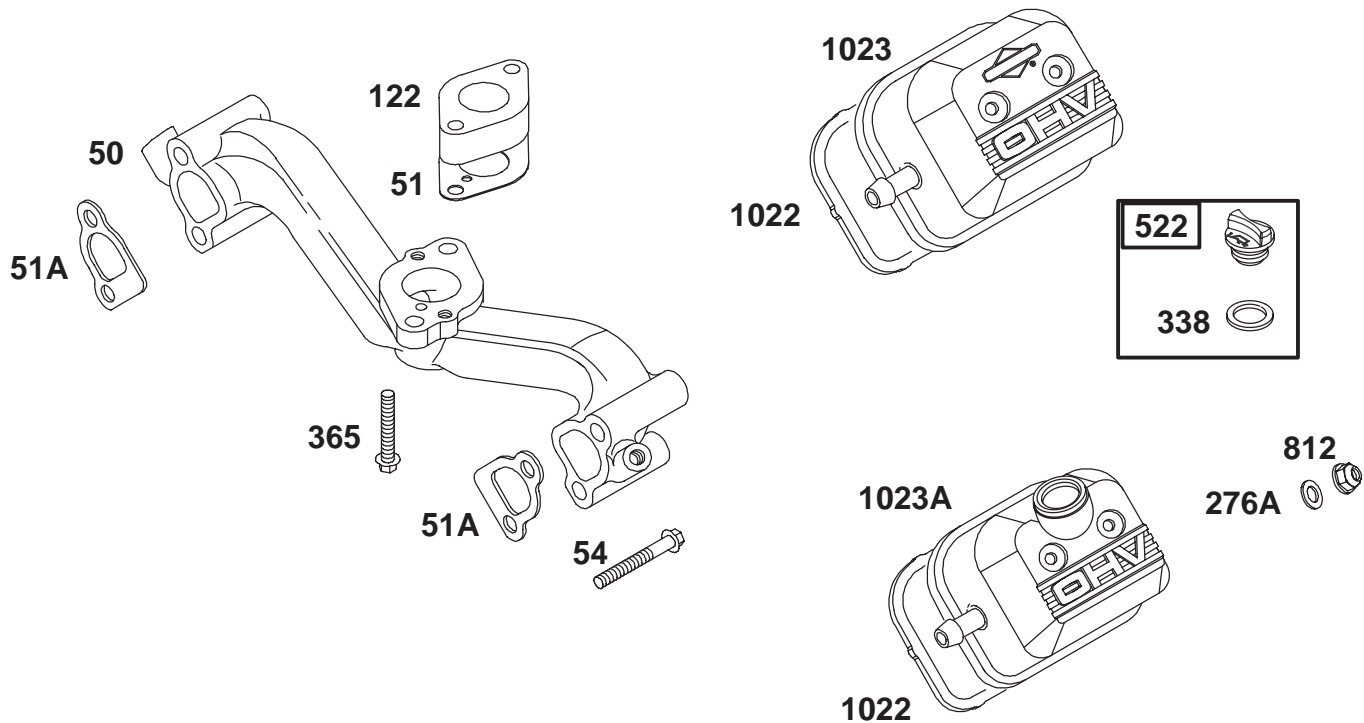

★ REQUIRES SPECIAL TOOLS TO INSTALL. SEE REPAIR INSTRUCTION MANUAL.

Assemblies include all parts shown in frames.

Intake Manifold and Rocker Cover Assembly Briggs and Stratton Model 350447-1259-E1

Ref. No.	Part No.	Qty.	Description
50	690754	1	Intake Manifold
★51	691694	1	Intake Gasket
Δ★51A	692035	1	Intake Gasket
54	690676	1	Screw (Intake Manifold)
122	690747	1	Carburetor Spacer
Δ★276A	691766	1	Sealing Washer
338	691312	1	Dipstick Gasket
365	690711	1	Screw (Carburetor)
522	491832	1	Dipstick/Fill Plug
Δ812	692055	1	Nut (Rocker Arm Cover)
Δ★1022	806039	1	Rocker Cover Gasket
1023	691494	1	Rocker Cover
1023A	690910	1	Rocker Cover

Ref. No.	Part No.	Qty.	Description

Δ Included in Valve Overhaul Gasket Set-Ref. 1095.

★ Included in Engine Gasket Set-Ref. 358.

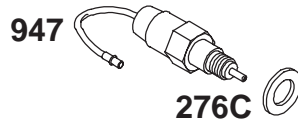
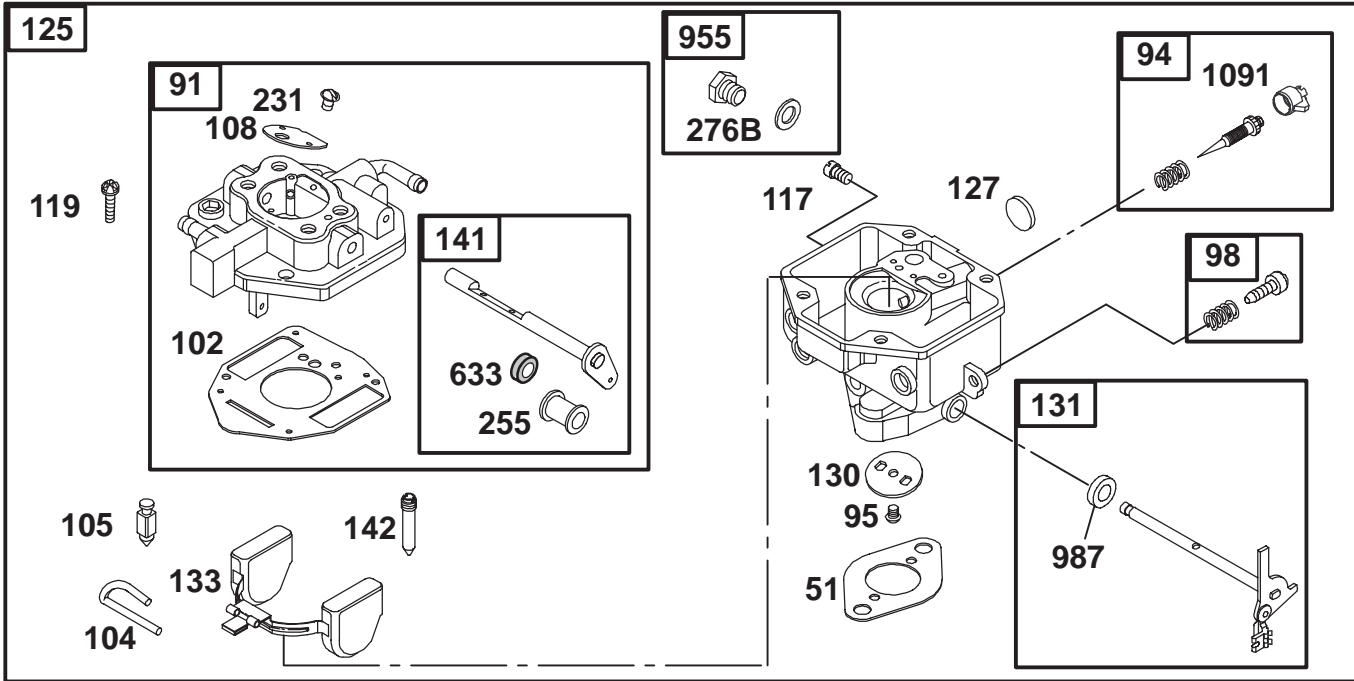

★ **REQUIRES SPECIAL TOOLS TO INSTALL. SEE REPAIR INSTRUCTION MANUAL.**

Assemblies include all parts shown in frames.

Carburetor Assembly Briggs and Stratton Model 350447-1259-E1

Ref. No.	Part No.	Qty.	Description
★51	691694	1	Intake Gasket
91	808396	1	Upper Carburetor Body
●94	808399	1	Idle Mixture Kit
●95	690718	1	Screw (Throttle Valve)
98	808981	1	Idle Speed Kit
●102	692077	1	Carburetor Body Gasket
●104	690723	1	Float Hinge Pin
●105	692078	1	Float Needle Valve
108	806134	1	Choke Valve
●117	806126	1	Main Jet (Standard)
	808413	1	Main Jet (High Altitude)
119	690720	1	Screw (Upper to Lower Carburetor Body)
125	808985	1	Carburetor
●127	690727	1	Welch Plug
130	806132	1	Throttle Valve
131	808974	1	Throttle Shaft Kit
133	806858	1	Carburetor Float
141	808398	1	Choke Shaft Kit
●142	806128	1	Carburetor Nozzle
●231	690718	1	Screw (Choke Valve)
●255	690721	1	Choke Shaft Bushing

Ref. No.	Part No.	Qty.	Description
●276B	690724	1	Sealing Washer
●276C	806137	1	Sealing Washer
●633	690722	1	Choke/Throttle Shaft Seal
947	692094	1	Fuel Solenoid
955	807723	1	Carburetor Plug
●987	806131	1	Throttle Shaft Seal
●1091	691516	1	Limiter Cap

● Included in Carburetor Overhaul Kit—Ref. 121.

★ Included in Engine Gasket Set—Ref. 358.

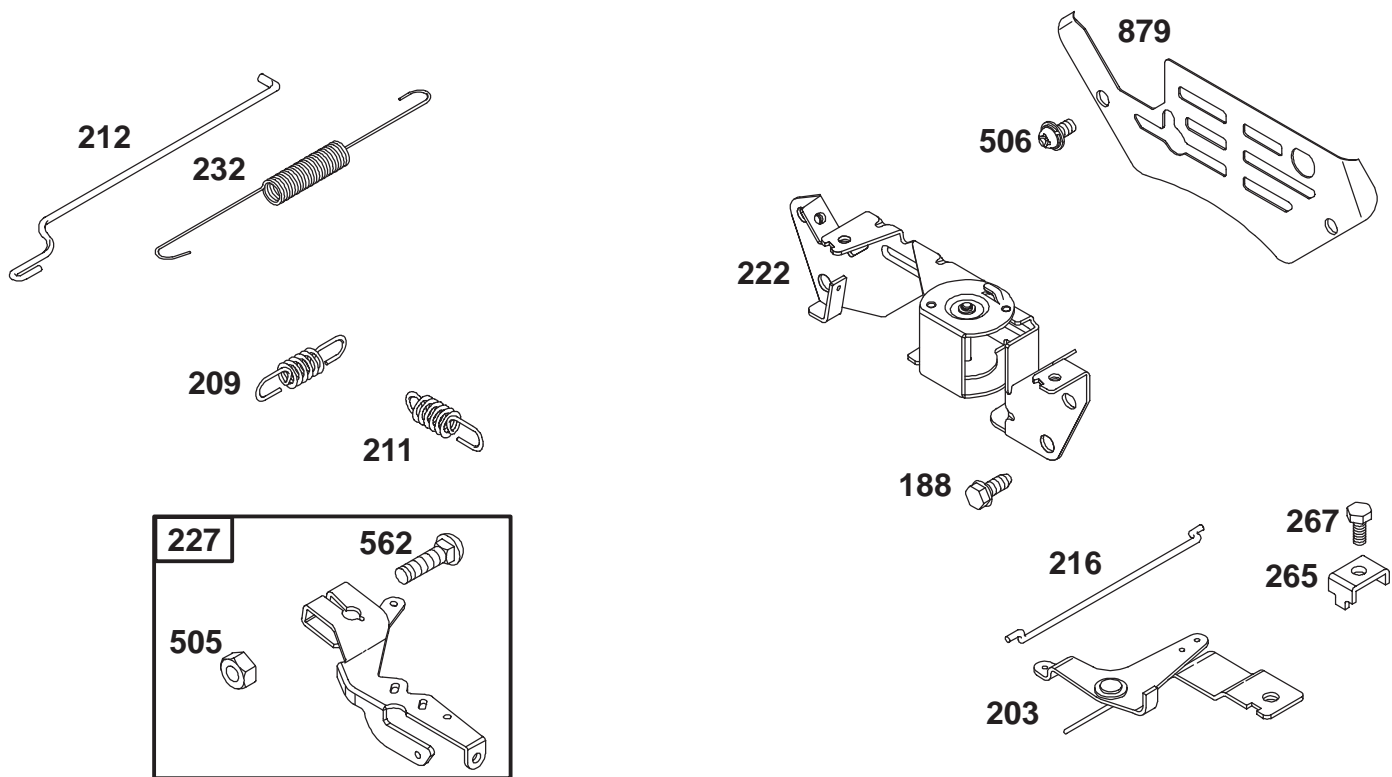

Assemblies include all parts shown in frames.

Governor Assembly Briggs and Stratton Model 350447-1259-E1

Ref. No.	Part No.	Qty.	Description
188	692056	1	Screw (Control Bracket)
203	690923	1	Bell Crank
209	806872	1	Governor Spring
211	806868	1	Governed Idle Spring
	692068	1	Governed Idle Spring (Secondary)
212	690712	1	Throttle Link
216	690705	1	Choke Link
222	808454	1	Control Bracket
227	690236	1	Governor Control Lever
232	692073	1	Governor Link Spring
265	691024	1	Casing Clamp
267	692083	1	Screw (Casing Clamp)
505	690238	1	Nut (Governor Control Lever)
506	690677	1	Screw (Carburetor Cover)
562	690239	1	Bolt (Governor Control Lever)
879	690757	1	Carburetor Cover

Ref. No.	Part No.	Qty.	Description

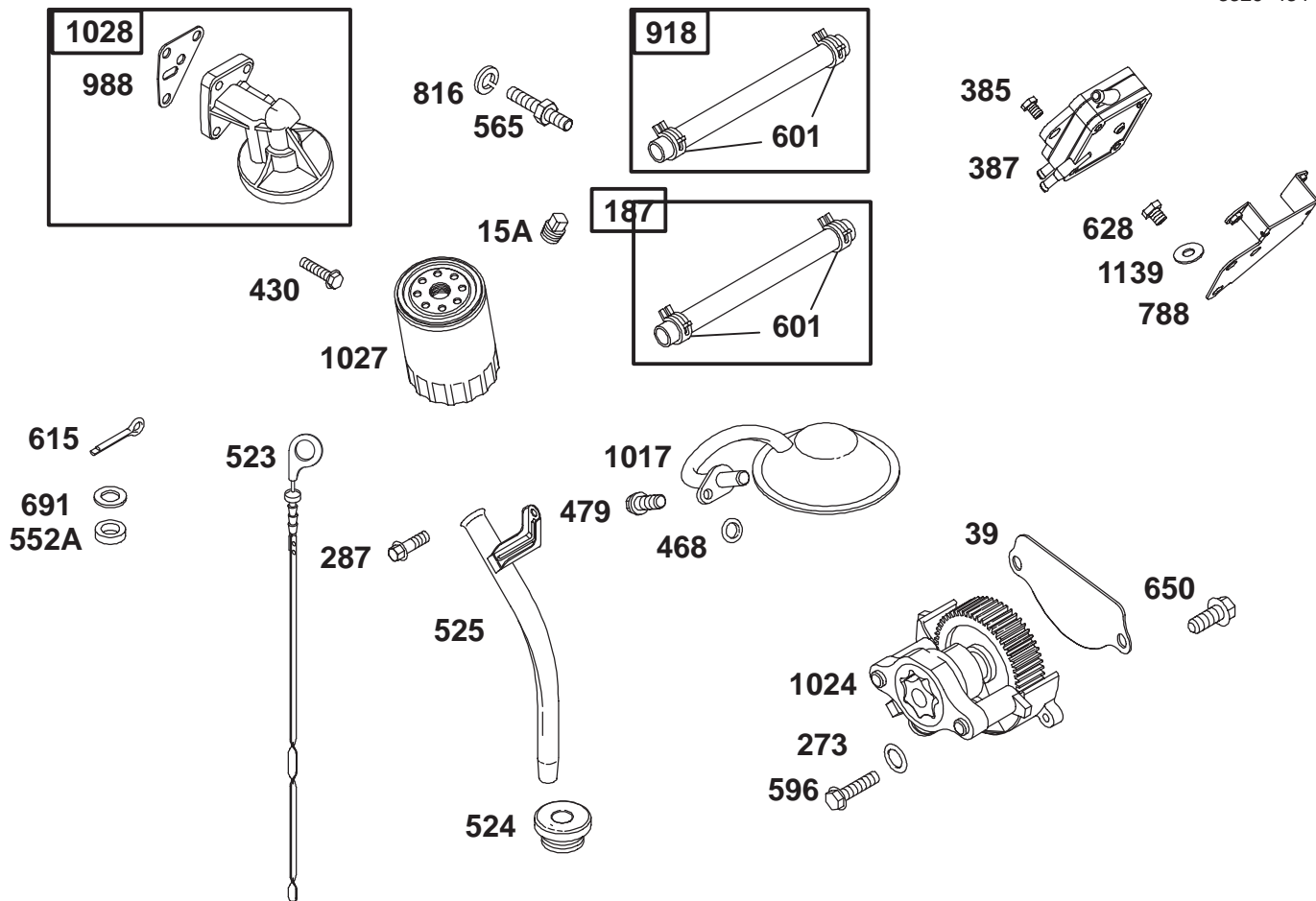

Assemblies include all parts shown in frames.

Fuel Pump, Oil Pump and Dipstick Assembly Briggs and Stratton Model 350447-1259-E1

Ref. No.	Part No.	Qty.	Description
15A	690283	1	Oil Drain Plug
39	690745	1	Oil Deflector
187	691050	1	Fuel Line (Cut to Required Length)
★273	690681	1	O-Ring Seal (Oil Pump)
287	692062	1	Screw (Dipstick Tube)
385	693169	1	Screw (Fuel Pump)
387	808969	1	Fuel Pump
430	690679	1	Bolt (Oil Pump)
★468	690690	1	O-Ring Seal (Oil Pump Screen)
479	692537	1	Screw (Oil Pump Screen)
523	693175	1	Dipstick
524	693172	1	Dipstick Tube Seal
525	693174	1	Dipstick Tube
552A	690701	1	Governor Crank Bushing
565	690682	1	Stud (Oil Filter)
596	691492	1	Screw (Oil Pump)

Ref. No.	Part No.	Qty.	Description
601	691038	1	Hose Clamp
615	691550	1	Governor Shaft Retainer
628	692062	1	Screw (Pump Bracket)
650	692539	1	Screw (Oil Deflector)
691	690680	1	Governor Shaft Seal
788	691559	1	Pump Bracket
816	690706	1	Washer (Oil Filter)
918	393815	1	Vacuum Hose
★988	692063	1	Oil Adapter Gasket
1017	690900	1	Oil Pump Screen
1024	693185	1	Oil Pump
1027	492932	1	Oil Filter
1028	808235	1	Oil Filter Adapter
1139	806497	1	Washer (Fuel Pump Bracket)

★ Included in Engine Gasket Set-Ref. 358.

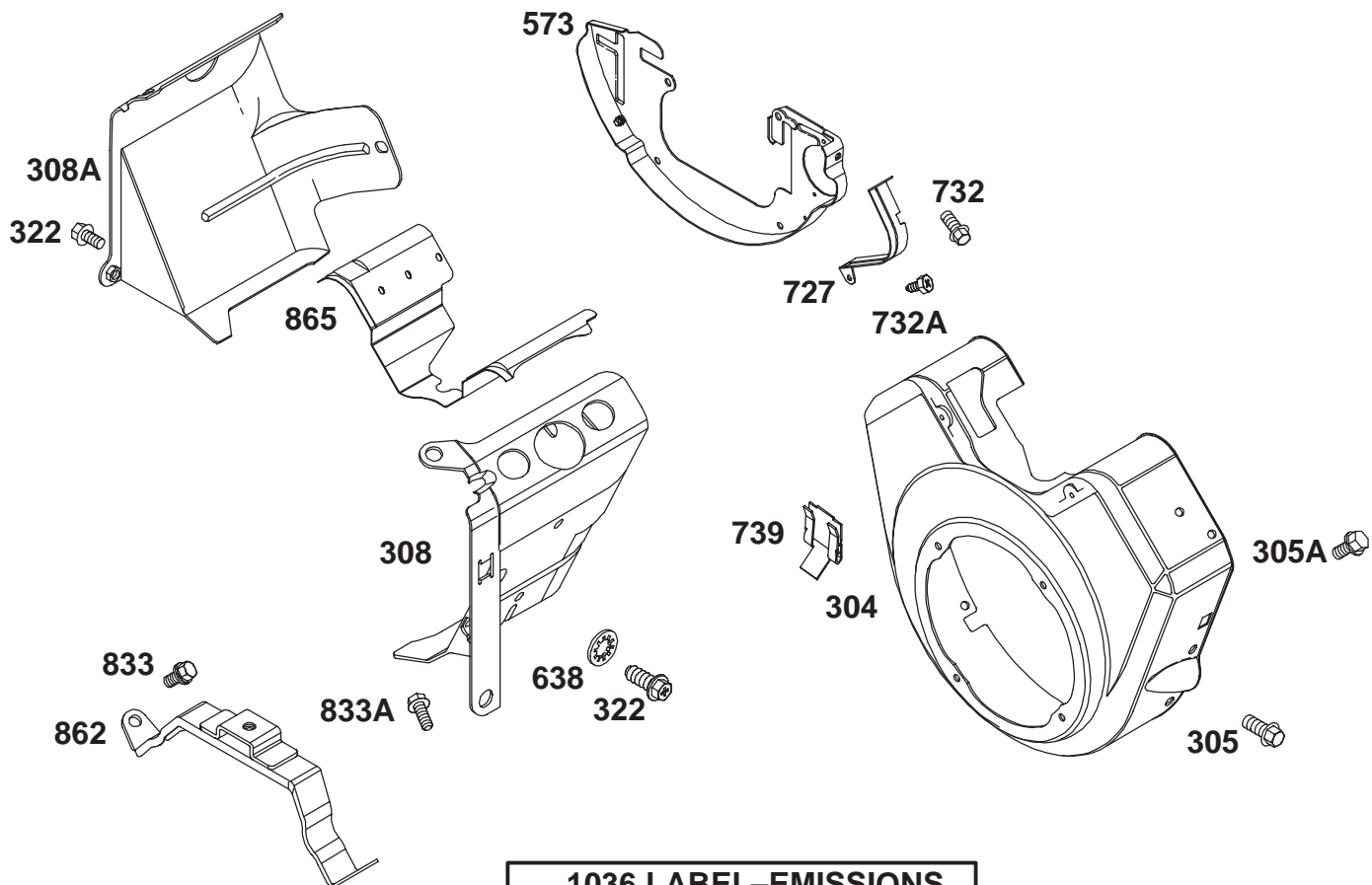

1036 LABEL-EMISSIONS

Assemblies include all parts shown in frames.

**Blower Housing Assembly
Briggs and Stratton Model 350447-1259-E1**

Ref. No.	Part No.	Qty.	Description
304	690929	1	Blower Housing
305	692539	1	Screw (Blower Housing)
305A	692056	1	Screw (Blower Housing)
308	806547	1	Cylinder Head Cover (Cylinder #1)
308A	806546	1	Cylinder Head Cover (Cylinder #2)
322	692539	1	Screw (Cylinder Head Cover)
573	690902	1	Back Plate
638	691551	1	Washer (Cylinder Head Cover)
727	690714	1	Starter Drive Cover
732	692539	1	Screw (Starter Drive Cover)
732A	690688	1	Screw (Starter Drive Cover)
739	690451	1	Debris Clip
833	692539	1	Screw (Cleaner Mounting Strap)
833A	690872	1	Screw (Cleaner Mounting Strap)

Ref. No.	Part No.	Qty.	Description
862	692153	1	Cleaner Mounting Strap
865	690750	1	Air Guide Cover
1036	806688	1	Emissions Label

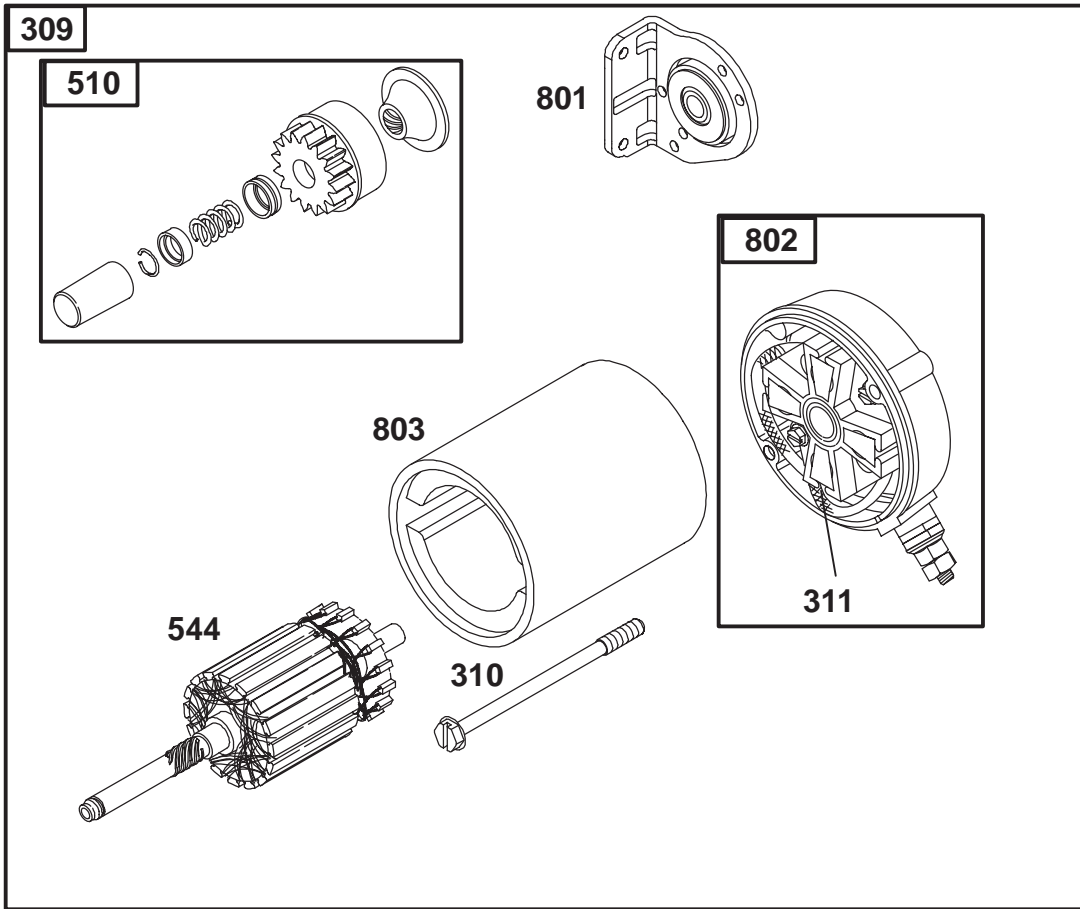

Assemblies include all parts shown in frames.

Starter Assembly Briggs and Stratton Model 350447-1259-E1

Ref. No.	Part No.	Qty.	Description
309	691564		Starter Motor
310	496880	1	Screw (Starter Housing)
311	496887	1	Brush Set
510	496881	1	Starter Drive
544	690855	1	Starter Armature
697	692062	1	Screw (Drive Cap)
801	808778	1	Drive Cap
802	496813	1	End Cap
803	690854	1	Starter Housing

Ref. No.	Part No.	Qty.	Description

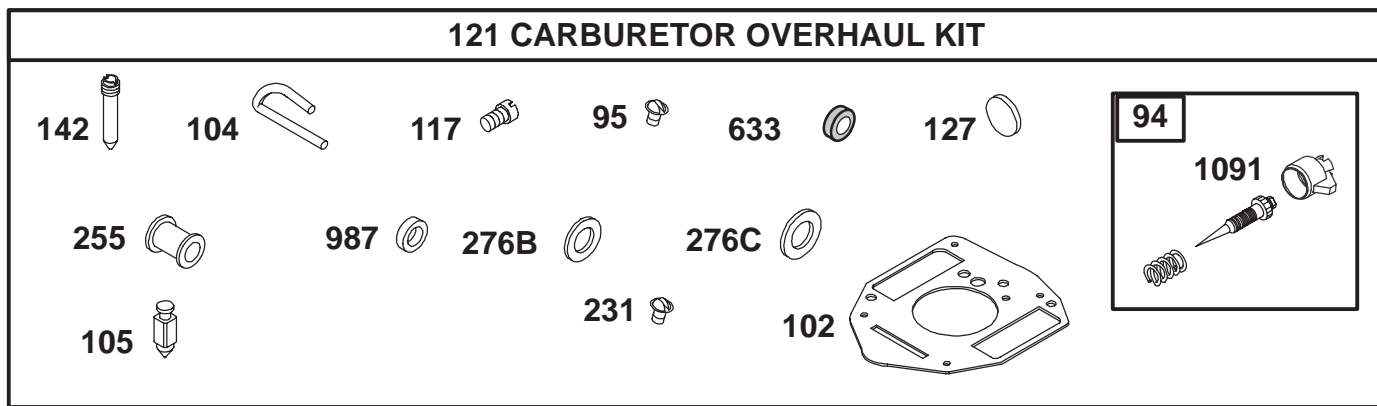

Assemblies include all parts shown in frames.

Carburetor Overhaul Kit Assembly Briggs and Stratton Model 350447-1259-E1

Ref. No.	Part No.	Qty.	Description
●94	808399	1	Idle Mixture Kit
●95	690718	1	Screw (Throttle Valve)
●102	692077	1	Carburetor Body Gasket
●104	690723	1	Float Hinge Pin
●105	692078	1	Float Needle Valve
●117	806126	1	Main Jet
121	808395	1	Carburetor Overhaul Kit
●127	690727	1	Welch Plug
●142	806128	1	Carburetor Nozzle
●231	690718	1	Screw (Choke Valve)
●255	690721	1	Choke Shaft Bushing
●276B	690724	1	Sealing Washer
●276C	806137	1	Sealing Washer
●633	690722	1	Choke/Throttle Shaft Seal
●987	806131	1	Throttle Shaft Seal
●1091	691516	1	Limiting Cap

Ref. No.	Part No.	Qty.	Description

● Included in Carburetor Overhaul Kit-Ref. 121.

Special Tools Reel Motor Seal Installation Tools

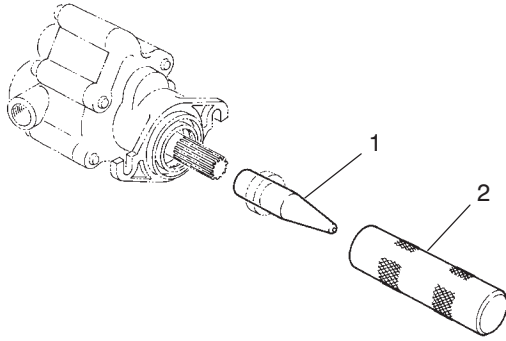

T-0727

Ref. No.	Part No.	Qty.	Description
1	TOR491430	1	Protector—Seal
2	TOR491450	1	Installer—Seal

Bed Knife Screw Tool No. TOR510880

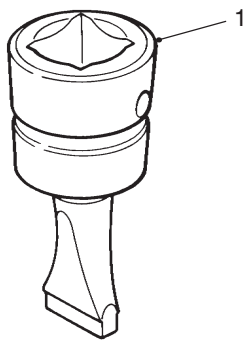

T-0729

Ref. No.	Part No.	Qty.	Description
1		1	Tool—Bed Knife Screw

Bearing Replacement Tool Kit No. TOR238900

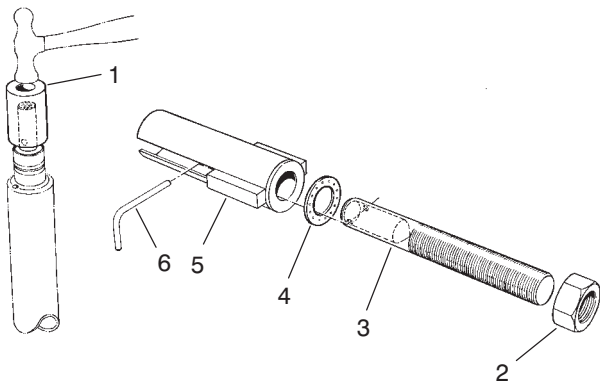

T-0730

Ref. No.	Part No.	Qty.	Description
1	23-8880	2	Driver—Bearing
2	3219-18	1	Nut—Hex
3	23-8840	1	Puller—Bolt
4	22-6090	1	Washer—Thrust
5	23-8850	1	Tube—Support
6	23-8860	1	Pin—Replacement, Bearing

Backlapping Brush Assembly No. 29-9100

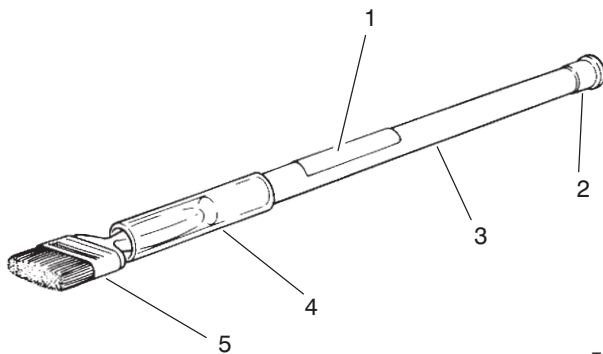

T-0731

Ref. No.	Part No.	Qty.	Description
1	12-9140	1	Decal
2	2410-18	1	Plug
3	29-9080	1	Handle
4	29-9090	1	Hose—Handle
5	36-4310	1	Brush

Note: Special tools may be ordered from: Owatonna Tool Company 2013 4th St. NW Owatonna, MN 55060

Special Tools (Continued)

Alignment Tool No. TOR200120

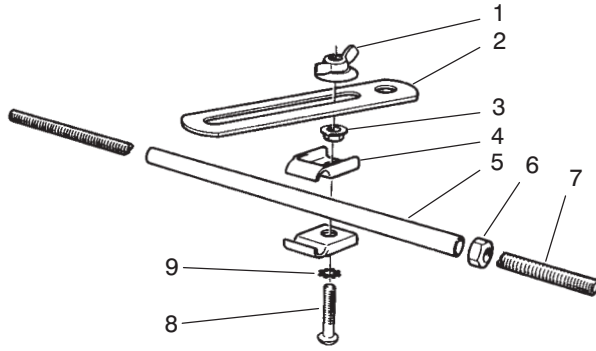

T-0732

Ref. No.	Part No.	Qty.	Description
1	3-4808	1	Nut-Wingl
2	20-0110	1	Bracket-Alignment
3	32123-20	1	Nut-Lock, Flange
4	3-6657	2	Clip-Skid
5	20-0070	1	Tube
6	3219-2	1	Nut-Hex
7	20-0080	1	Rod
8	32122-35	1	Screw-Head, Truss
9	3255-8	1	Washer-Lock, Int. Tooth

**Note: Special tools may be ordered from: Owatonna Tool Company
2013 4th St. NW
Owatonna, MN 55060**

