

TORO®MODEL NO. 09120 – 80001
thru 90001 & UPOPERATOR'S
MANUAL**GREENS AERATOR**

To assure maximum safety, optimum performance, and to gain knowledge of the product, it is essential that you or any other operator of the aerator read and understand the contents of this manual before the engine is ever started. Pay particular attention to the **SAFETY INSTRUCTIONS** highlighted by this symbol —

The safety alert symbol means **CAUTION, WARNING** or **DANGER** — personal safety instruction. Failure to comply with the instruction may result in personal injury.



FOREWORD

The Greens Aerator has advanced concepts in engineering, design and safety; and if maintained properly, will give excellent service.

Since this is a high-quality product, Toro is concerned about the future use of the machine and safety of the user. Therefore, read this manual to familiarize yourself with proper set-up, operation and maintenance instructions. The major sections of the manual are:

1. Safety Instructions
2. Set-up Instructions
3. Before Operating
4. Operation
5. Maintenance

Certain information in this manual is emphasized. DANGER, WARNING and CAUTION identify personal safety related information. IMPORTANT identifies mechanical information demanding special attention. Be sure to read this directive because it deals with the possibility of damaging a part or parts of the machine. NOTE identifies general information worthy of special attention.

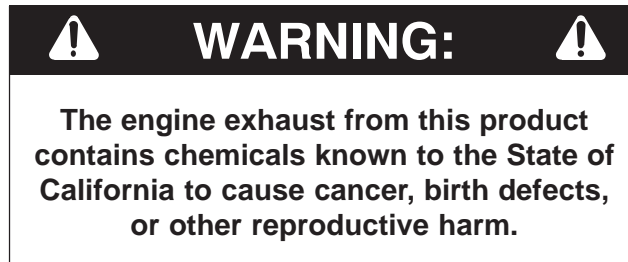

OPTIONAL SPARK ARRESTER

In some places a spark arrester muffler must be used because of local, state or federal regulations. The spark arrester available from your local Toro Distributor is approved by the United States Department of Agriculture and the United States Forest Service. Order the following part from your local authorized Toro Distributor:

1—Spark Arrester Screen, Part No. 94—5301

When the Aerator is used or operated on any California forest, brush or grass covered land, a properly operating spark arrester must be attached to the muffler. The operator is violating state law, Section 442 Public Resources Code if a spark arrester is not used.

Whenever you have questions or need service, contact your local authorized Toro Distributor. In addition to having a complete line of accessories and professional turf care service technicians, the distributor has a complete line of genuine TORO replacement parts to keep your machine operating properly. Keep your TORO all TORO. Buy genuine TORO parts and accessories.

TABLE OF CONTENTS

	Page		Page
SAFETY INSTRUCTIONS	4–5	Inspection and Cleanup After Use	19
SAFETY AND INSTRUCTION DECALS	6	DAILY MAINTENANCE CHECKLIST	20
SPECIFICATIONS	7	LUBRICATION	21
LOOSE PARTS	8	HOLE QUALITY TROUBLESHOOTING	22
SET–UP INSTRUCTIONS	9	MAINTENANCE	23–29
BEFORE OPERATING	10–12	Changing Hydraulic System Oil	23
Activate and Charge Battery	10	Change Transaxle Oil	23
Check Crankcase Oil	10	Belt Adjustments	23
Fill Fuel Tank with Gasoline	11	Adjusting Service Brake	25
Check Hydraulic System Fluid	12	Check Coring Head Chains	25
CONTROLS	13	Servicing Roller Chains	25
TINE SELECTION	14–15	Coring Head Timing	26
OPERATING INSTRUCTIONS	16–19	Removing Coring Head	26
Starting/Stopping Engine	16	Adjusting Brake Assembly	27
Install Tines	16	Adjusting Clutch Solenoid	27
Adjust Coring Depth	16	Adjusting Throttle Control Rod	28
Check Frame Height	17	Battery Care	28
Operating Procedure	17	Battery Storage	28
Check Interlock System	17	ELECTRICAL SCHEMATIC	29
Override System	17	HYDRAULIC SCHEMATIC	29
Training Period	19	MAINTENANCE SCHEDULE	30
Before Aerating	19	IDENTIFICATION AND ORDERING	31
Aerating Procedure	19	THE TORO PROMISE	Back Cover
Transport Operation	19		



SAFETY INSTRUCTIONS

Improper use or maintenance of the machine can result in injury. To reduce the potential for injury, comply with the following safety instructions.

BEFORE OPERATING

1. Read and understand the contents of this Operator's Manual before operating the machine. Become familiar with all controls and know how to stop quickly. A free replacement manual is available by sending complete Model and Serial Number to:

The Toro Company
8111 Lyndale Avenue South
Minneapolis, Minnesota 55420

2. Do not allow children to operate the machine. Do not allow adults to operate the machine without proper instruction.

3. Before attempting to start engine, disengage traction drive and move gear shift to neutral.

4. Remove all debris or other objects that might interfere with operation. Keep all bystanders away from the work area.

5. Locate and mark all under ground obstructions such as irrigation components, electrical or telephone lines.

6. Keep all shields and safety devices in place. If a shield, safety device or decal is defective or damaged, repair or replace it before operation is commenced. Also tighten any loose nuts, bolts and screws to assure machine is in safe operating condition.

7. Do not operate machine while wearing sandals, tennis shoes, sneakers or shorts. Also, do not wear loose fitting clothing which could get caught in moving parts. Always wear long pants and substantial shoes. Wearing safety glasses, safety shoes, ear protection and a helmet is advisable and required by some local ordinances and insurance regulations.

8. Fill fuel tank with gasoline before starting the engine. Avoid spilling gasoline. Since gasoline is flammable, handle it carefully.

- A. Use an approved gasoline container.
- B. Do not fill tank while engine is hot or running.
- C. Do not smoke while handling gasoline.
- D. Fill fuel tank outdoors and up to about one inch (25 mm) from top of the tank, not the filler neck.
- E. Wipe up any spilled gasoline.

WHILE OPERATING

9. Start engine when traction drive is disengaged, and gear shift lever is in neutral.

10. Do not run the engine in a confined area without adequate ventilation. Exhaust fumes are hazardous and could possibly be deadly.

11. Using the machine demands attention, and to prevent loss of control:

- A. Use only in daylight or when there is good artificial light.
- B. Watch for holes or other hidden hazards.
- C. Do not transport machine close to a sand trap, ditch, creek or other hazard.

12. If the tines strike a solid object or the machine vibrates abnormally, shut the engine off. Remove high tension wires from spark plugs to prevent possibility of accidental starting. Check coring head and traction unit for damage and defective parts. Repair any damage before restarting the engine and operating the tines. Be sure tines are in good condition and all bolts are tight.

13. Do not touch engine or muffler while engine is running or soon after it is stopped. These areas could be hot enough to cause a burn.

14. Before leaving the operator's position — behind handle or leaving machine unattended, raise coring head, raise lockup brackets, disengage traction drive, move gear shift to neutral and shut OFF engine.

MAINTENANCE

15. Disconnect high tension wires from spark plugs to prevent accidental starting of the engine when servicing, adjusting or storing the machine.

16. If traction unit must be tipped to perform maintenance or an adjustment, drain gasoline from fuel tank and oil from crankcase.

17. To reduce potential fire hazard, keep the engine free of excessive grease, grass, leaves and accumulations of dirt. Never wash a warm engine or electrical connections with water.

18. Be sure machine is in safe operating condition by keeping nuts, bolts and screws tight. Check the tine mounting bolts and nuts frequently to be sure they are tightened to specification.

19. If the engine must be running to perform a maintenance adjustment, keep hands, feet, clothing and other parts of the body away from the tines and other moving parts.

20. Make sure all hydraulic line connectors are tight, and all hydraulic hoses and lines are in good condition before applying pressure to the system.

21. Before disconnecting or performing any work on the hydraulic system, all pressure in system must be relieved by stopping engine and lowering implement to the ground.



SAFETY INSTRUCTIONS

22. Keep body and hands away from pin hole leaks or nozzles that eject hydraulic fluid under high pressure. Use paper or cardboard, not hands, to search for leaks. Hydraulic fluid escaping under pressure can have sufficient force to penetrate skin and do serious damage. If fluid is ejected into the skin it must be surgically removed within a few hours by a doctor familiar with this form of injury or gangrene may result.

23. Do not overspeed the engine by changing governor settings. To be sure of safety and accuracy, have an Authorized TORO Distributor check maximum engine speed with a tachometer.

24. Engine must be shut off before checking oil or adding oil to the crankcase.

25. Allow engine to cool before storing machine in any enclosure such as a garage or storage shed. Make sure the fuel tank is empty if machine is to be stored in excess of 30 days. Do not store machine near any open flame or where gasoline fumes may be ignited by a spark. Always store gasoline in a safety approved, red metal container.

26. Perform only those maintenance instructions described in this manual. If major repairs are ever needed or assistance is desired, contact an Authorized Toro Distributor. To ensure optimum performance and

safety, always purchase genuine TORO replacement parts and accessories to keep the Toro all TORO. NEVER USE "WILL-FIT" REPLACEMENT PARTS AND ACCESSORIES MADE BY OTHER MANUFACTURERS. Look for the TORO logo to assure genuineness. Using unapproved replacement parts and accessories could void the warranty of The Toro Company.

SOUND PRESSURE LEVEL

This unit has an equivalent continuous A-weighted sound pressure at the operator ear of: 92 dB(A), based on measurements of identical machines per Directive 84/538/EEC and amendments.

SOUND POWER LEVEL

This unit has a sound power level of: 104 dB(A)/1 pW, based on measurements of identical machines per Directive 84/538/EEC and amendments.

VIBRATION LEVEL

Hand-Arm

This unit does not exceed a vibration level of 8.5 m/s² at the hands based on measurements of identical machines per ISO 5349 procedures.

SAFETY AND INSTRUCTION DECALS

The following decals are installed on the machine. If any become damaged or illegible, replace it. The decal part number is listed below and in your parts catalog. Replacement can be ordered from your Authorized Toro Distributor.



On Interlock Switch Assemblies
(Part No. 53-4420)



On Shift Lever Retainer
(Part No. 66-4710)



On Engine
(Part No. 66-9050)



On Pulley Guard
(Part No. 94-9111)

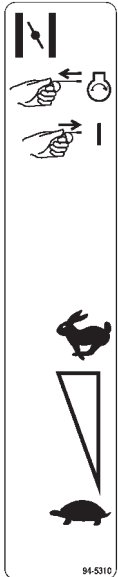
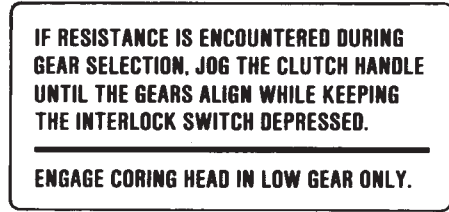

On Engine
(Part No. 94-5310)



On Brake Handle
(Part No. 59-9860)

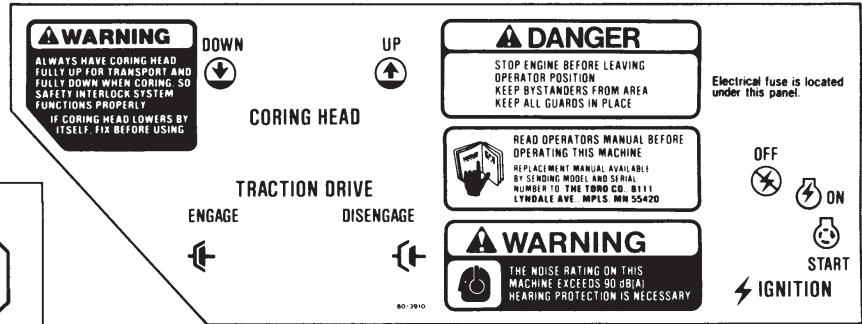

On Control Panel
(Part No. 80-3910)



On Right and Left side of Frame
and on Coring Head
(Part No. 67-5360)



Near Fuel Tank Cap
(Part No. 27-7310)



On Front of Coring Head Cover
(Part No. 59-9930)

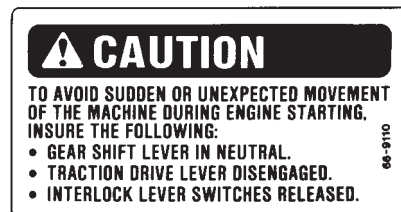

On Engine
(Part No. 66-9110)

SPECIFICATIONS

Engine: Briggs & Stratton, Vanguard®, 4 cycle, air cooled, 2 cylinder 16 hp @ 3600 rpm, 29.3 cu. in displacement. Electric start. Large capacity dual element air cleaner. Full pressure lubrication 3.5 pint oil capacity. Solid state electronic ignition.

Electrical: 12 volt battery, 32 amp-hour. 16 amp alternator. Ignition switch and interlock switches on control handle, transmission and coring head clutch.

Fuel Capacity: 4.5 gallons unleaded gasoline.

Traction Drive: Double banded V-belt from mechanical clutch on engine to Peerless Model 2361 transaxle. Two speeds forward and one reverse. Wheels driven individually by chains from transaxle.

Ground Speed:

1st Gear Forward: 1.04 mph @ 3600 rpm (coring)
2nd Gear Forward: 3.10 mph @ 3600 rpm (transport)
Reverse: 1.88 mph @ 1800 rpm.

Ground Clearance: 4 inches.

Tires/Wheels: Two steering tires (front): 13 X 5.00-6, 2 ply, rib tread tubeless.

Two drive tires (rear): 18 X 9.50-8, 4 ply, Rib Terra tubeless. Drop center demountable rims, greaseable tapered roller bearings.

Recommended tire pressure for front and back tires is 10 psi.

Frame: Welded steel construction — tricycle.

Service Brake: Disc type mounted to transaxle.

Controls: Traction clutch, coring head hydraulic lift and key switch on control console. Throttle and choke on engine. Transaxle shift lever on frame. Interlock switches and service brake on steering handle.

Implement Drive: Triple banded V-belt from engine to coring head.

Coring Unit Construction: Welded steel frame construction with four crankshafts mounted in precision ball bearings. Crankshafts drive four coring arms/tine heads.

Drive: No. 50 O-ring sealed roller chain from countershaft to coring crankshafts.

Lift: Single hydraulic cylinder powered by a vane type pump. Control valve actuated by lift control lever.

Tine Heads: 4 individual heads each holding three tines. Deflector chutes direct cores rearward away from drive components.

Coring Width: 27 inches

Hole Pattern: 2.25 inches X 2.5 inches

Coring Depth: Up to 3.5 inches.

Tines: Case hardened tubing, hollow tapered design. 5/8" tines standard. 12 tines required per unit.

Dimensions:

Length:	76 inches
Width:	55.5 inches
Height:	39 inches
Wheelbase:	44 inches
Weight:	1236 pounds

Optional Accessories:

Windrower	Model 09150
Coring Head Stand	Model 09152
Tire Scrapers	Model 09151

See Tine Chart on page 14 for list of tines.

LOOSE PARTS

NOTE: Use this chart as a checklist to assure all parts have been received. Without these parts, total set-up cannot be completed.

Note: Some parts may already be installed on machine.

Description	Qty.	Use
Set Screw Key Roll Pin	1 1 1	Install Handle Assembly
Rear Wheel Lug Nuts	2 8	Install Rear Wheels
Tine—5/8"	12	Install on Coring Head
Ignition Key	1	
Frame Height Gauge	1	
Timing Rods	4	Use to Time Coring Head
Operator's Manual	1	Read Before Operating Machine
Parts Catalog	1	
Engine Manual	1	
Registration Card	1	Fill Out And Return To Toro

SET-UP INSTRUCTIONS

INSTALL HANDLE ASSEMBLY

1. Insert key into keyway on handle mounting shaft (Fig. 1).

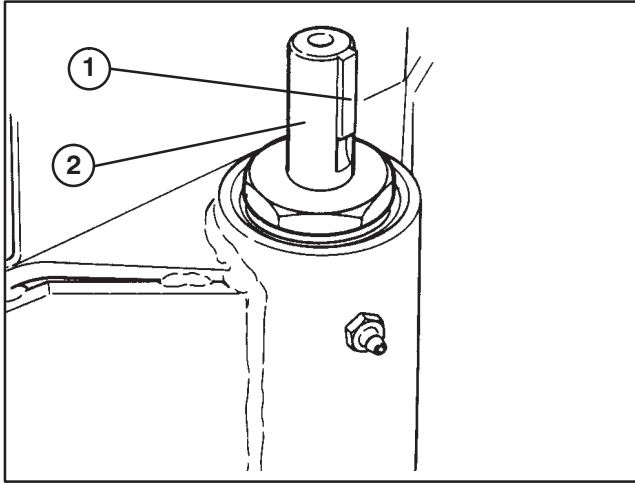

Figure 1

1. Key
2. Handle mounting shaft

2. Align keyway in handle assembly with key and slide handle onto shaft (Fig. 2).

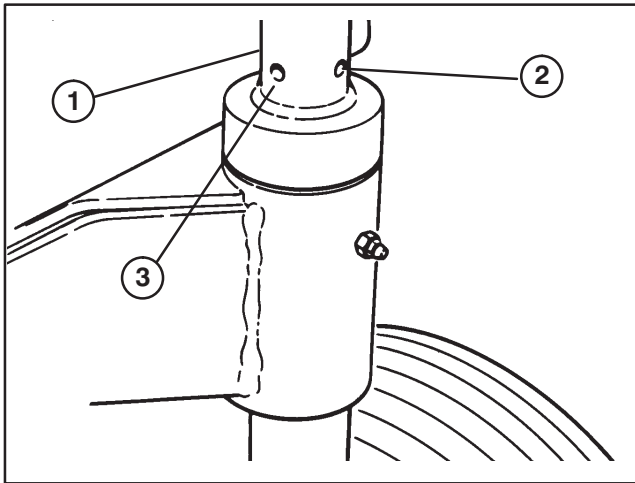

Figure 2

1. Handle assembly
2. Set screw
3. Roll pin

IMPORTANT: Make sure wire harness hangs freely and is not wrapped around handle.

3. Insert roll pin into mounting hole and drive pin in until flush with edge of handle assembly (Fig. 2).

4. Apply loctite #242 to set screw. Install screw to handle assembly and tighten (Fig. 2).

INSTALL REAR WHEELS

1. Secure wheels to spindle hubs with lug nuts (Fig. 3). Torque nuts to 65–90 ft–lb.

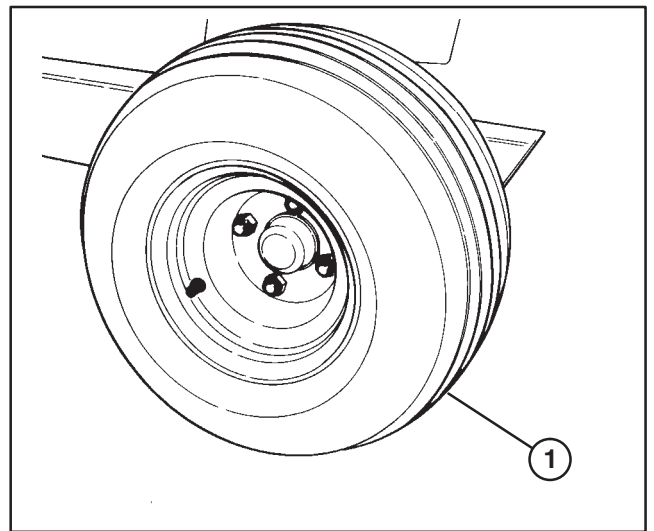

Figure 3

1. Rear wheel

CHECK TIRE PRESSURE

The tires are over-inflated for shipping. Therefore, release some of the air to reduce the pressure. Correct air pressure is 10 psi.

BEFORE OPERATING

ACTIVATE AND CHARGE BATTERY

1. Since battery is not filled with electrolyte or activated, bulk electrolyte with 1.260 specific gravity must be purchased from a local battery supply outlet.



CAUTION

Wear safety goggles and rubber gloves when working with electrolyte. Charge the battery in a well ventilated place so gasses produced while charging can dissipate. Since the gases are explosive, keep open flames and electrical spark away from the battery; do not smoke. Nausea may result if the gases are inhaled. Unplug charger from electrical outlet before connecting to or disconnecting charger leads from battery posts.

2. Remove wing nuts and washers securing battery clamp to battery bolts and remove battery from machine. Remove filler caps from battery and slowly fill each cell until electrolyte is just above the plates (Fig. 4).

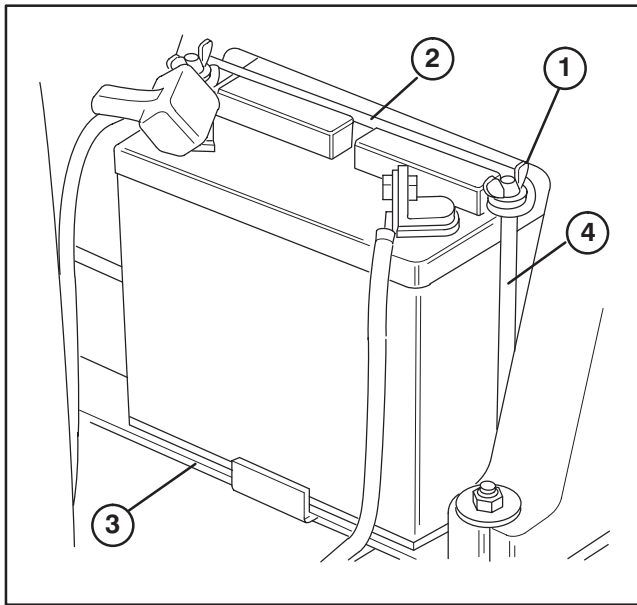

Figure 4

- | | |
|------------------------|-----------------|
| 1. Wing nuts & washers | 3. Battery pad |
| 2. Battery clamp | 4. Support rods |

3. Replace filler caps and connect a 3 to 4 amp battery charger to the battery posts. Charge the battery at a rate of 3 to 4 amperes for 4 to 8 hours.

4. When battery is charged, disconnect charger from electrical outlet and battery posts.

5. Remove filler caps. Slowly add electrolyte to each cell until level is up to fill ring. Install filler caps.

IMPORTANT: Do not over fill battery. Electrolyte will overflow onto other parts of the machine and severe corrosion and deterioration will result.

6. Mount battery on battery pad with terminal posts toward rear of machine (Fig. 4).

7. Secure battery with to battery bolts with clamp, washers and wing nuts (Fig. 4).

8. Install the positive cable (rubber boot over end) to the positive (+) terminal and the negative cable (black) to the negative (-) terminal of the battery and secure with carriage bolts, lockwashers and nuts. Slide the rubber boot over the positive terminal to prevent possible short-out from occurring (Fig.4).

CHECK CRANKCASE OIL

The engine is shipped with 3-1/2 pints of oil in the crankcase; however, level of oil must be checked before and after the engine is first started.

1. Position machine on a level surface.
2. Remove dipstick and wipe it with a clean rag. Insert dipstick down into dipstick tube and tighten. Make sure it is seated fully. Remove dipstick and check level of oil (Fig. 5). If oil level is low, add enough oil to raise level to FULL mark on dipstick.

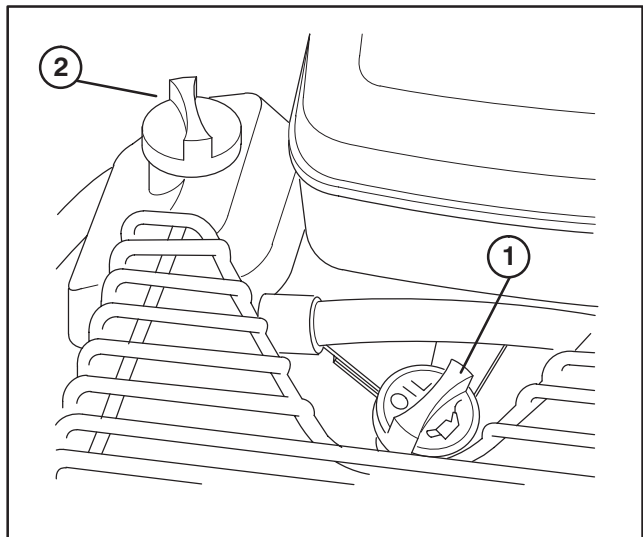
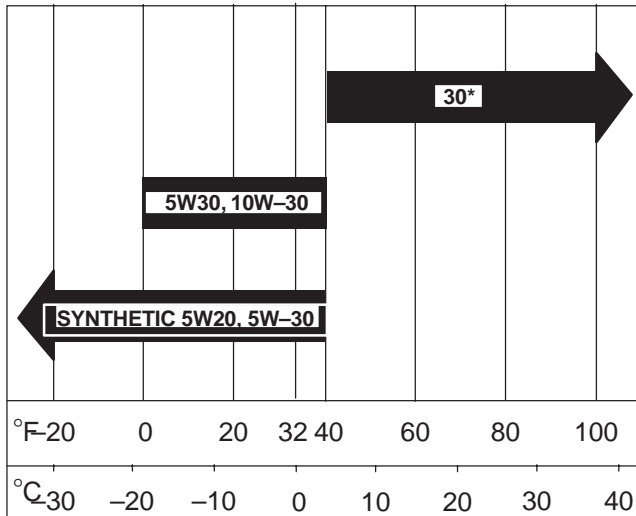

Figure 5

- | |
|---------------|
| 1. Dipstick |
| 2. Filler cap |

3. Remove filler cap and pour oil into filler neck until level is at the FULL mark on dipstick. The engine uses any high-quality oil having the American Petroleum Institute — API — “service classification” SE, SF or SG. Oil viscosity — weight — must be selected according to ambient temperature. Temperature/ viscosity recommendations are:

BEFORE OPERATING



* SAE 30 oil, if used below 40°F (4°C) will result in hard starting and possible engine bore damage due to inadequate lubrication.

IMPORTANT: Check level of oil every 8 operating hours or daily. Initially, change oil after the first 8 hours of operation; thereafter, under normal conditions, change oil after every 50 hours of operation and filter after every 100 hours of operation. However, change oil more frequently when engine is operated in extremely dusty or dirty conditions, under heavy load or in high ambient temperatures.

FILL FUEL TANK WITH GASOLINE

This engine is certified to operate on unleaded gasoline. Use clean, fresh, unleaded gasoline with a minimum of 85 octane. Do not mix oil with gasoline. Purchase fuel in quantity that be used within to 30 days assure fuel freshness. Use Briggs & Stratton Gasoline Additive (See your Authorized Briggs & Stratton Service Dealer for Part No. 5041 or the single-use pouch.)

In countries other than the U.S.A., leaded gasoline may be used if it is commercially available and unleaded is unavailable.

Note: Some fuels called oxygenated or reformulated gasolines, are gasoline blended with alcohols or ethers. Excessive amounts of these blends can damage the fuel system or cause performance problems. Do not use gasoline which contains Methanol. If any undesirable operating symptoms occur, use gasoline with a lower percentage of alcohol or ether.

1. Remove cap from the fuel tank (Fig. 6) and fill the 4.5 gallon tank to within 1 inch from the top with unleaded gasoline. Install fuel tank cap tightly.



DANGER

Because gasoline is flammable, caution must be used when storing or handling it. Do not fill fuel tank while engine is running, hot or when machine is in an enclosed area. Vapors may build up and be ignited by a spark or flame source many feet away. **DO NOT SMOKE** while filling the fuel tank to prevent the possibility of an explosion. Always fill fuel tank outside and wipe up any spilled gasoline before starting engine. Use a funnel or spout to prevent spilling gasoline before starting engine and fill tank to about 1 inch (25 mm) below the filler neck. Store gasoline in a clean safety-approved container and keep the cap in place on the container. Keep gasoline in a cool, well-ventilated place; never in an enclosed area such as a hot storage shed. To assure volatility, do not buy more than a 30 day supply of gasoline. Gasoline is a fuel for internal combustion engines; therefore, do not use it for any other purpose. Since many children like the smell of gas, keep it out of their reach because the fumes are explosive and dangerous to inhale.

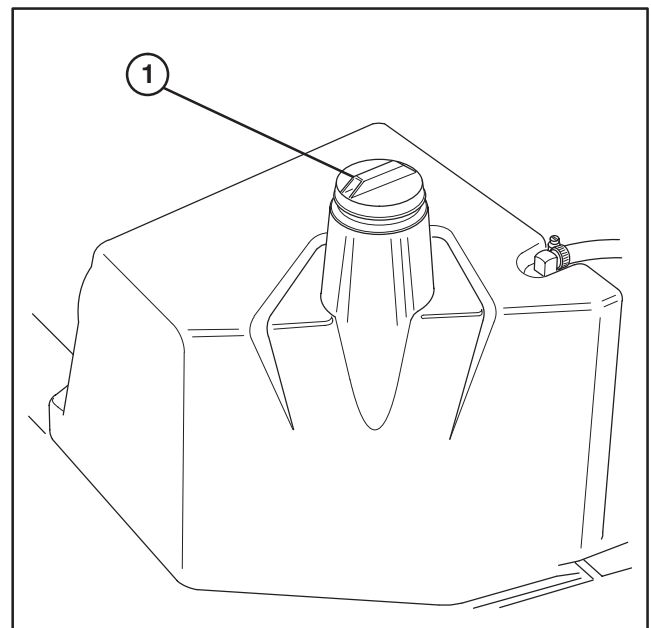

Figure 6

1. Vented fuel tank cap

2. Wipe up gasoline that may have spilled to prevent a fire hazard.

BEFORE OPERATING

CHECK HYDRAULIC SYSTEM FLUID

The hydraulic system is designed to operate on SAE 10 W–30 engine oil or, as a substitute, SAE 10 W–40 engine oil. The machine's reservoir is filled at the factory with approximately 2.7 pints of SAE 10 W–30 engine oil. However, check level of hydraulic fluid before engine is first started and daily thereafter.

1. Position machine on a level surface and raise coring head to the full up position.
2. Remove dipstick cap (Fig. 7) from filler neck and wipe it with a clean rag. Insert dipstick cap into filler neck; then remove it and check level of fluid. If level is not within 1/2 inch from the full mark on dipstick, add SAE 10W–30 engine oil to raise level to full mark. Do not overfill.
3. Install dipstick filler cap onto filler neck.

4. Run engine for approximately 1 minute, recheck level of fluid and add oil as required.

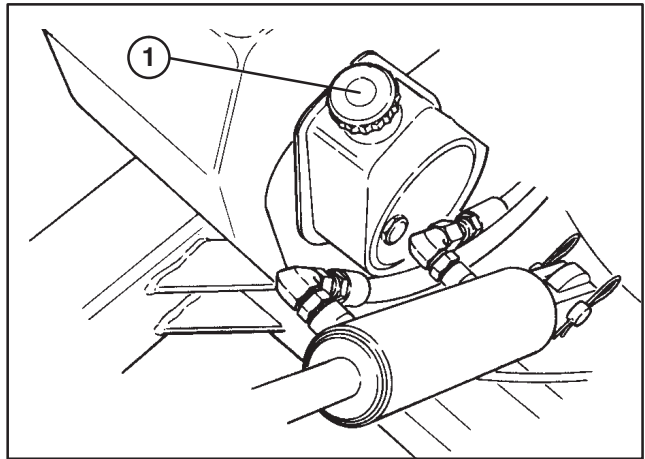

Figure 7

1. Dipstick cap

CONTROLS

Choke (Fig. 8) — To start a cold engine, close carburetor choke by pulling choke control outward to the ON position. After engine starts, regulate choke to keep engine running smoothly. As soon as possible, open the choke by pushing it inward to the OFF position. A warm engine requires little or no choking.

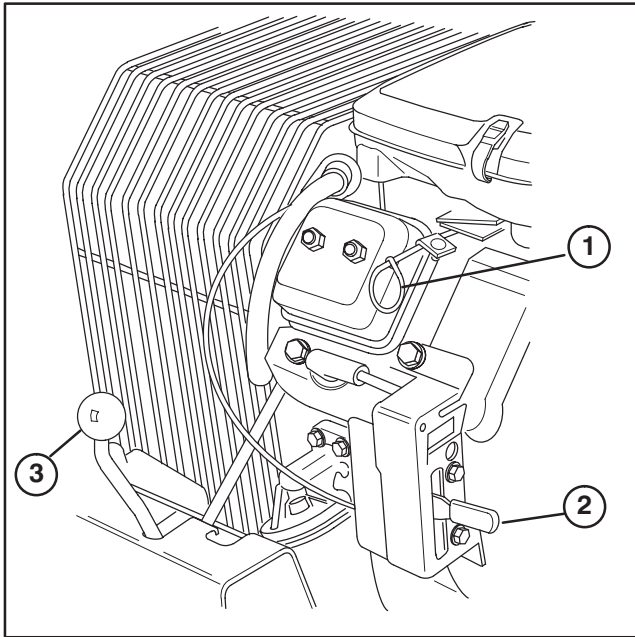

Figure 8

1. Choke
2. Throttle
3. Gear shift lever

Throttle (Fig. 8) — Throttle is used to operate engine at various speeds. Moving throttle upward increases engine speed — FAST; rearward decreases engine speed — SLOW. The throttle controls the speed of the coring head and, in conjunction with traction clutch, controls ground speed of the machine.

Gear Shift Lever (Fig. 8) — Transmission has two forward speeds, neutral and reverse, and has an inline shaft pattern. Do not shift while unit is moving, as transmission damage may occur.

Ignition Switch (Fig.9) — The ignition switch, which is used to start and stop the engine, has three positions: OFF, ON and START. Rotate key clockwise — START position — to engage starter motor. Release key when engine starts. The key will automatically return to the ON position. To shut engine off, rotate key counterclockwise to the OFF position.

Traction Drive Lever (Fig. 9) — Shift to desired gear and move traction drive lever to engage position to move forward or reverse. One of the hand operated interlock levers (Fig.10) must be engaged to shift traction drive lever. Also, parking brake is automatically engaged or disengaged with traction drive lever and interlock lever operation .

Coring Head Lever (Fig. 9) — Raises and lowers coring head and engages and disengages drive.

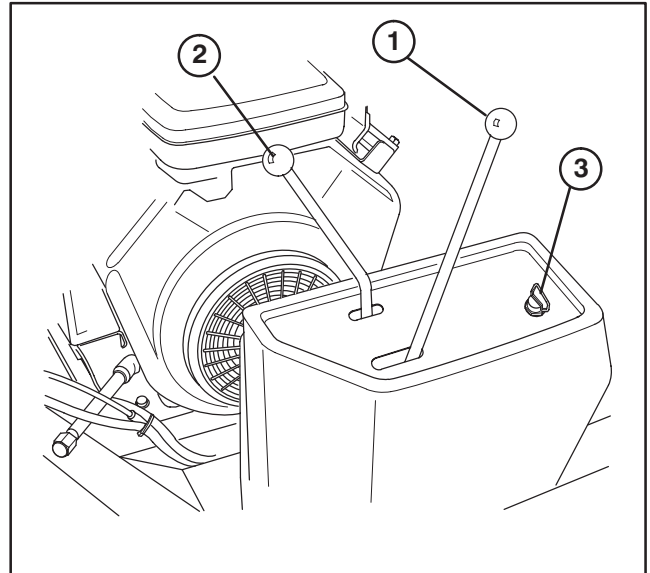

Figure 9

1. Traction drive lever
2. Coring head lever
3. Ignition switch

Interlock Lever Switches (2) (Fig. 10) — Switches permit engine operation when coring head is lowered. They also hold the traction drive lever in engaged position. One handle switch must be activated before engaging traction drive or lowering the coring head, when engine is running.

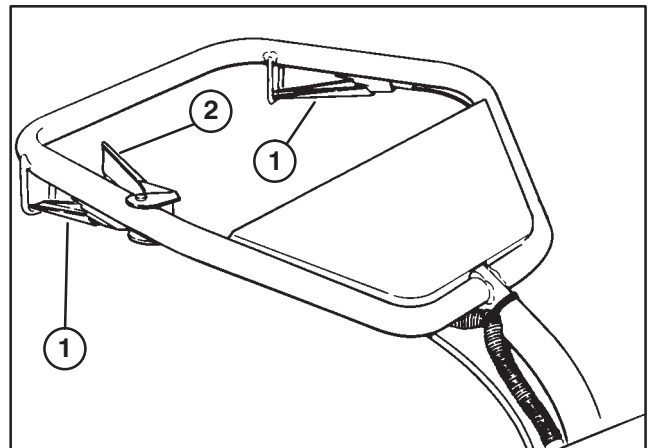
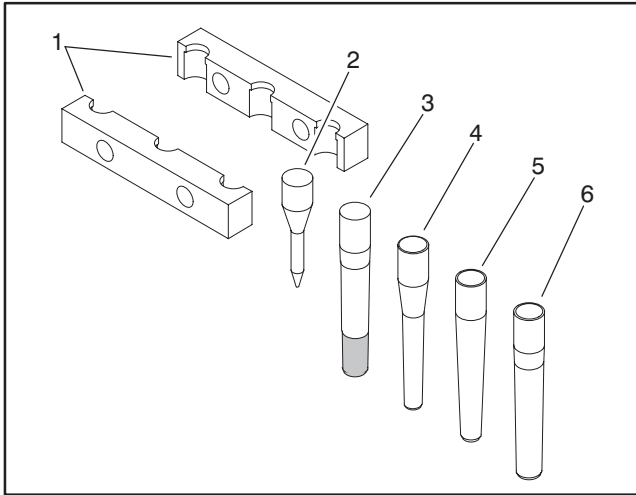

Figure 10

1. Interlock lever switches
2. Service brake

Service Brake (Fig. 10) — Used to slow down traction operation.

TINE SELECTION



Ref. No.	Part No.	Description	No. Used
1	59-2500	Block	8
2	77-5320	Tine - Spiker, 5/16" x 3 1/4"	12
3	59-9770	Tine - Coring, Long Wear 5/8" x 4 3/4"	12
4	59-3690	Tine - Coring, 3/8" x 4 3/4"	12
5	94-3419	Tine - Coring, 1/2" x 4 3/4"	12
6	59-3670	Tine - Coring, 5/8" x 4 3/4"	12

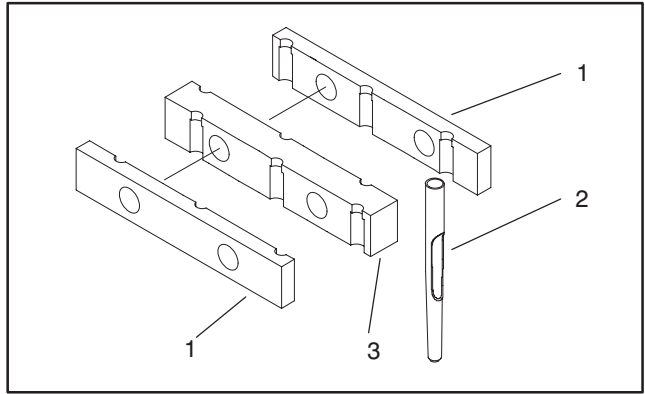

Ref. No.	Part No.	Description	No. Used
*	94-6823	Kit- 1/4" Open Center Tine (Opt.)	1
1	94-3421	Block - Outboard	8
2	94-3417	Tine - Open Center 1/4" x 4 1/4"	24
3	94-6822	Block - Inboard	4

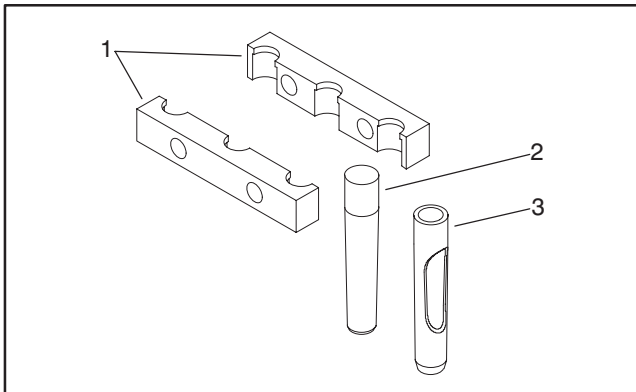

Ref. No.	Part No.	Description	No. Used
1	62-4610	Block	8
2	62-4600	Tine - Coring, 3/4" x 4 3/4"	12
3	92-7941	Tine - Open Center, 3/4" x 4 3/4"	12

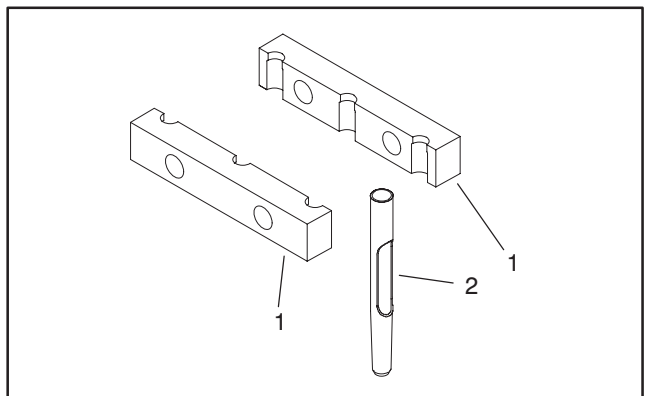

Ref. No.	Part No.	Description	No. Used
*	94-6814	Kit - 3/8" Open Center Tine (Opt.)	1
1	94-3420	Block	8
2	94-3418	Tine - Open Center, 3/8" x 4 3/4"	12

TINE SELECTION

1/4" SPIKER KIT – MODEL NO. 09153

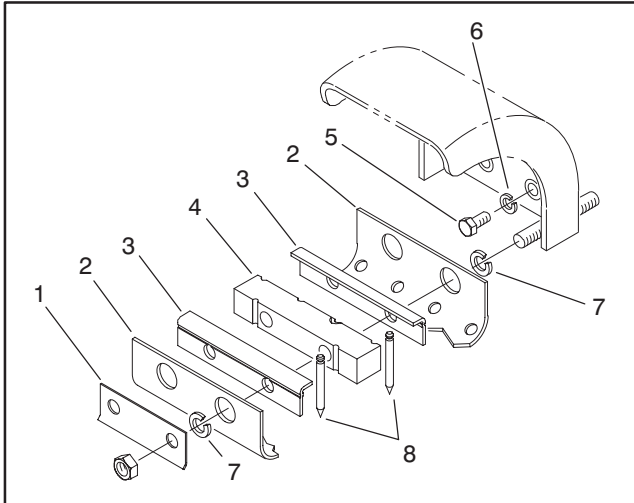

Ref. No.	Part No.	Description	No. Used
1	77-5360	Plate – Holder, Turf	4
2	77-5380	Guard – Turf	4
3	77-5350	Clamp – Holder, Tine	8
4	77-5370	Holder – Tine	4
5	323-4	Screw – HH	16
6	3253-21	Washer – Lock	16
7	3253-7	Washer – Lock	16
8	77-5340	Tine – Spiker, 1/4" x 2 1/2"	28

OPERATING INSTRUCTIONS

STARTING/STOPPING ENGINE

1. Make sure both wires are installed on spark plugs.
2. Make sure traction drive is disengaged and gear shift lever is in Neutral.
3. Pull choke lever out to ON position — when starting a cold engine — and throttle lever to Mid position.
4. Insert key into ignition switch and rotate it clockwise to start the engine. Release key when engine starts. Gradually return the choke lever to the OFF position (lever all the way in) after the engine starts and warms up.

IMPORTANT: To prevent overheating of the starter motor, do not engage starter longer than 10 seconds. After 10 seconds of continuous cranking, wait 60 seconds before engaging starter motor again.

5. Make sure coring head is in the raised position.

Note: When engine is started for the first time, or after overhaul of the engine, transmission or axle, operate the machine in forward and reverse for one to two minutes to be sure of proper operation of all parts.

6. To stop the engine, move throttle control downward to SLOW position and turn ignition key to “OFF”.

INSTALL TINES

(Refer to Tine Chart on Page 14 for tine selection)

1. Start the engine: refer to Starting/Stopping instructions.
2. Move coring head lever to “UP” position to raise coring head.
3. Stop engine and raise lock-up brackets on each side of chassis (Fig. 11). Lower coring head until it rests on brackets.

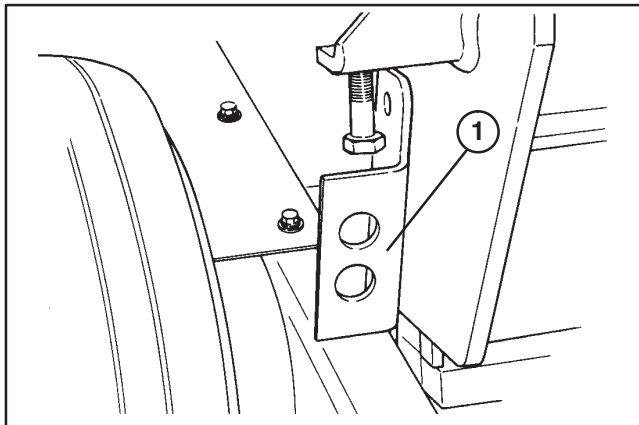

Figure 11

1. Lock-up bracket

4. Loosen (2) hex nuts on each tine block until tines can be inserted. Insert tines, from bottom, until they bottom out on flange in top of tine block (Fig. 12).

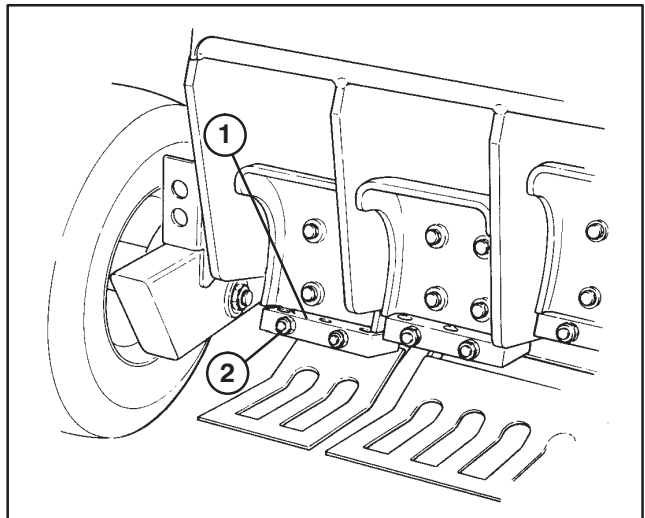

Figure 12

1. Tine block
2. Mounting nut

5. Tighten mounting nuts to 100–110 ft/lb. torque (Fig. 12).

6. Check clearance between tines and slots in turf guards. If side play is evident in the tine arms, adjust both wear plates outboard to eliminate the possibility of the tines contacting turf guard and damaging tines.

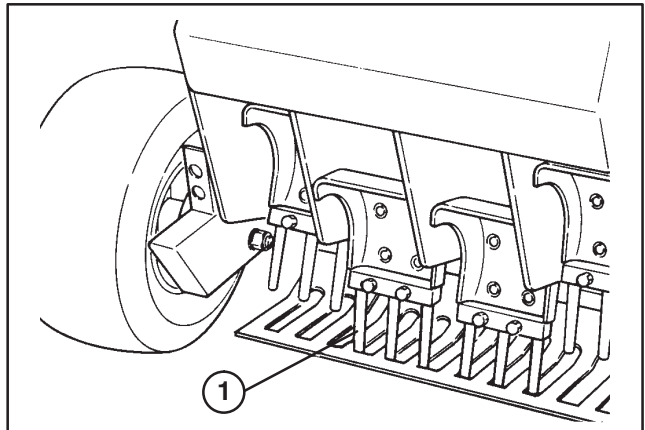

Figure 13

1. Tine

ADJUST CORING DEPTH

1. Raise coring head and engage lock-up brackets.
2. Loosen jam nut on top of adjusting bracket (Fig. 14).
3. Thread adjusting screw into bracket to increase coring depth and out to decrease depth (Fig. 14).
4. Best performance and coring depth is achieved when distance from end of screw head to bracket is 11/16” (Fig. 14).

IMPORTANT: Do not adjust screw to a setting less than 11/16” or damage to turf guards may occur.

5. Make sure adjustments are the same on both sides of coring head and tighten jam nuts.

OPERATING INSTRUCTIONS

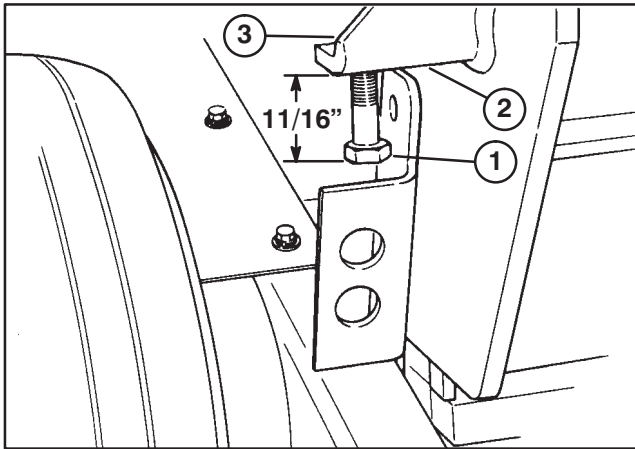

Figure 14

1. Coring depth adjustment screw
2. Adjusting bracket
3. Jam nut

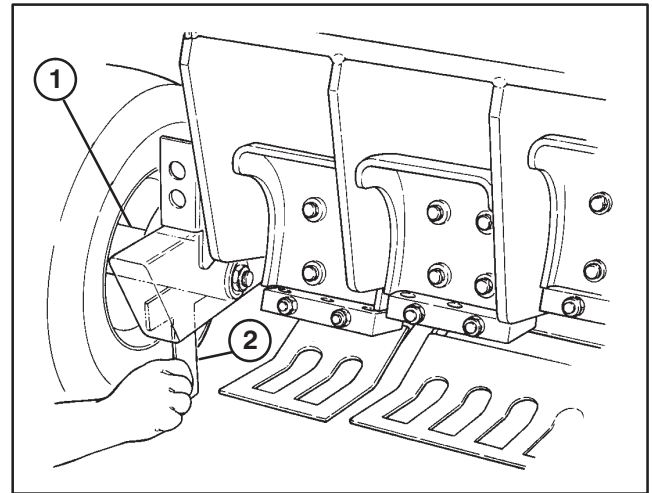

Figure 16

1. Rear wheel spindle
2. Height gauge

CHECK FRAME HEIGHT

1. Position machine on a level surface.
2. Check tire pressure. Tire pressure should be 10 psi. Make sure all tires are equal pressure.
3. Slide short end of frame height gauge under front axle to verify height. Gauge should contact axle when on floor. Check both sides (Fig. 15).

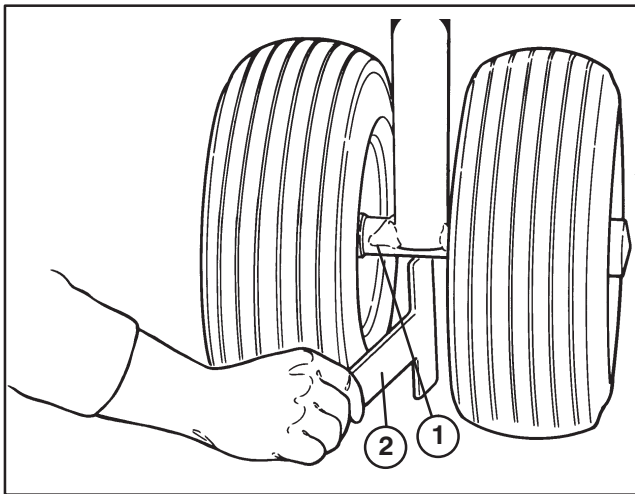

Figure 15

1. Front axle
2. Height gauge

4. Increase or decrease tire pressures to attain required height.
5. Repeat procedure using long end of height gauge on each rear wheel spindle (Fig. 16).
6. Regulate tire pressure as required. Minimum tire pressure is 6 psi.

OPERATING PROCEDURE

1. Make sure wires are installed on spark plugs.
2. Start the engine: refer to Starting/Stopping instructions.
3. Make sure coring head is in the up position.
4. Squeeze left interlock lever against handle.
5. Move shift lever to "L" (low) for Coring or "H" (high) for Transport.

Note: If resistance is encountered during gear selection, jog the clutch handle until the gears align. Do not shift gears while machine is moving. **DO NOT FORCE SHIFT LEVER AS DAMAGE WILL OCCUR.**

6. Move traction drive lever to engage position.
7. To engage and lower coring head, move coring head lever to down position and hold until coring head is completely lowered.

CHECK INTERLOCK SYSTEM

The purpose of the safety interlock system is to prevent the engine from cranking or starting unless the traction drive lever is disengaged and the coring head is raised. It also interrupts engine operation if a handle mounted interlock lever is not activated.

To check interlock system:

1. Position machine on a flat, open area. Start the engine: refer to Starting and Stopping instructions.
2. Check traction switch (Fig. 17) with a continuity tester or ohm meter and replace if damaged. The switch must be closed when the gear shift lever is in a gear. The switch must open when shifting between Neutral, First, and Second gears.
3. To adjust switch, loosen mounting screws and reposition switch as required.

OPERATING INSTRUCTIONS

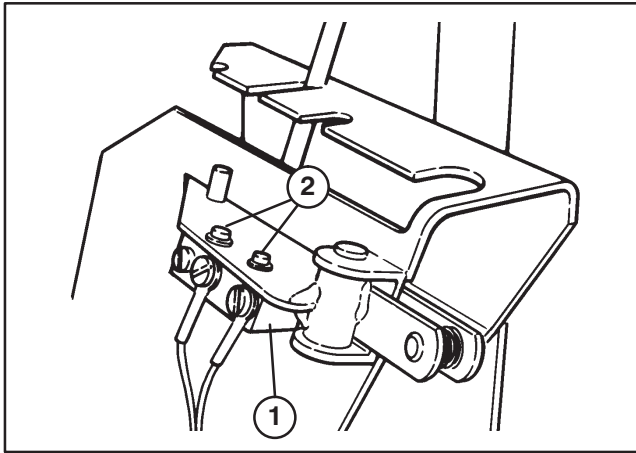

Figure 17

1. Traction switch
2. Mounting screws

4. If coring head is in raised position and engine will not start, or engine continues to run when coring head is down and interlock lever(s) released, there is a defect in the interlock system, proceed to step 5.

5. Check coring head switch (Fig. 18) with a continuity tester or ohm meter and replace if damaged. The switch plunger must be depressed when the coring head is in the raised position.

Note: Before coring head switch can be adjusted, coring head drive belt must be properly adjusted; refer to instructions for adjusting coring head drive belt on page 24.

6. If an adjustment to the switch is required, proceed as follows:

- A. Stop engine and lower coring head onto stand.
- B. Remove override pin from storage bracket on front of coring head cover (Fig. 19).
- C. Push down on override lever (Fig. 20) until holes in lever bracket and coring bracket are aligned, then insert pin thru holes.
- D. Loosen adjusting screw jam nut and (2) flange nuts (Fig. 18).
- E. Turn ignition switch to start position, but do not start engine.
- F. While holding ignition switch in the start position, tighten adjusting screw until engine cranks.
- G. Release ignition switch and tighten adjusting screw one more turn.
- H. Tighten adjusting screw jam nut and (2) flange nuts.
- I. Restart the engine and raise the coring head.
- J. Stop the engine, remove the override pin and reinstall in storage bracket.
- K. Start engine and check all modes of operation. Coring head should not run when on coring head lock-up brackets.

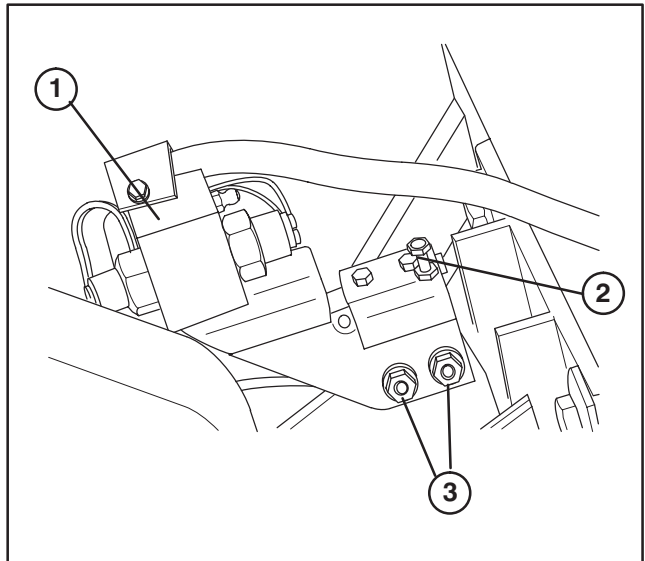

Figure 18

1. Coring head switch
2. Adjusting screw & jam nut
3. Mounting screws

OVERRIDE SYSTEM

The coring head is equipped with a release mechanism which allows the engine to be started when the coring head is in the lowered position.

1. Remove override pin from storage bracket on front of coring head cover (Fig. 19).

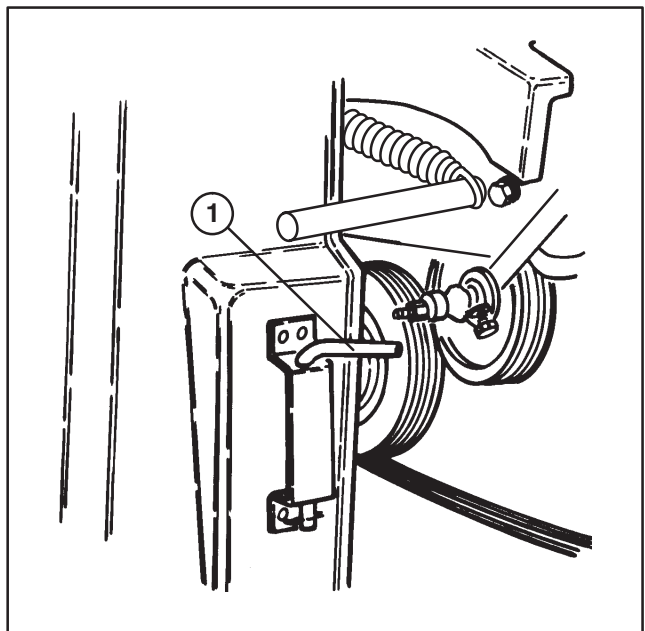

Figure 19

1. Override pin

2. Push down on override lever until holes in lever bracket and coring head are aligned, then insert pin thru holes (Fig. 20).

OPERATING INSTRUCTIONS

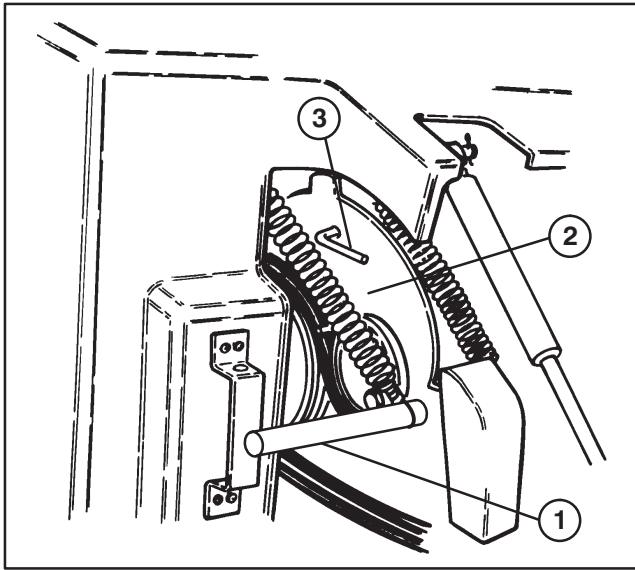

Figure 20

1. Override lever
2. Lever bracket
3. Override pin

3. Restart the engine and raise the coring head.
4. Stop the engine, remove the pin and reinstall in storage bracket.

TRAINING PERIOD

Before aerating greens with the Greens Aerator, it is suggested that you find a clear area and practice starting and stopping, raising and lowering coring head, turning, etc. This training period will be beneficial to the operator in gaining confidence in the performance of the Greens Aerator.

BEFORE AERATING

Inspect the work area for debris and determine the best direction and pattern to operate machine. Mark all sprinkler head and obstructions

AERATING PROCEDURES

1. Approach the work area with the gear shift lever in the “L” (low) position.
2. Lower coring head when desired starting position is attained. Make sure coring head is engaged before the tines are within one inch of the turf.
3. Use rubber guides hanging from front of chassis to align rows.



CAUTION

Always have coring head fully raised when transporting and fully lowered when coring so safety interlock system functions correctly. If coring head lowers by itself, correct malfunction before continuing operation.

TRANSPORT OPERATION

Make sure coring head is in the up position and coring head lock—up brackets are up. Set the gear shift lever in the “H” (high) position if faster ground speed is required. Use the service brake to slow the machine while going down steep hills to avoid loss of control. Always approach rough areas at a reduced speed and cross severe undulations carefully.

INSPECTION AND CLEAN-UP AFTER USE

At the completion of operation, thoroughly wash the machine with a garden hose without a nozzle so excessive water pressure will not cause contamination and damage to seals and bearings. After cleaning, it is recommended the machine be inspected for possible hydraulic fluid leaks, damage or wear to hydraulic and mechanical components and the tines checked for sharpness. Lubricate grease fittings immediately after every washing.

DAILY MAINTENANCE CHECKLIST

Daily Maintenance: (duplicate this page for routine use)

Check proper section of Operator's Manual for fluid specifications

Maintenance Check Item ➡	Daily Maintenance Check For Week Of _____						
	MON	TUES	WED	THURS	FRI	SAT	SUN
✓ Safety Interlock Operation							
✓ Brake Operation							
✓ Fuel Level							
✓ Engine Oil							
✓ Frame Height							
✓ Air Filter/Pre-cleaner Condition							
Clean Engine Cooling Fins							
✓ Hydraulic System Oil Level							
✓ Unusual Operating Noises							
✓ Tine & Stomper Arm Condition							
✓ Hydraulic Hoses for Damage							
✓ Fluid Leaks							
✓ Tire Pressure							
Tighten Loose Fasteners							
Lubricate Roller Chains ¹							
Lubricate All Grease Fittings ¹							
Touch-up Damaged Paint							

¹ = Immediately after every washing, regardless of the interval listed.

Notation for areas of concern: Inspection performed by _____

Item	Date	Information
1		
2		
3		
4		
5		
6		
7		
8		

LUBRICATION

LUBRICATION

The Greens Aerator has grease fittings that must be lubricated daily with No. 2 General Purpose Lithium Base Grease.

The bearings and bushings that must be lubricated are: front wheels (Fig. 21), rear wheel spindles (Fig. 22), front handle shaft (Fig. 23), traction roller latch pin (Fig. 25) and reverse speed control lever (Fig. 26) coring head switch (Fig. 27). Lubricate roller chain (Fig. 24) daily with SAE 30 oil.

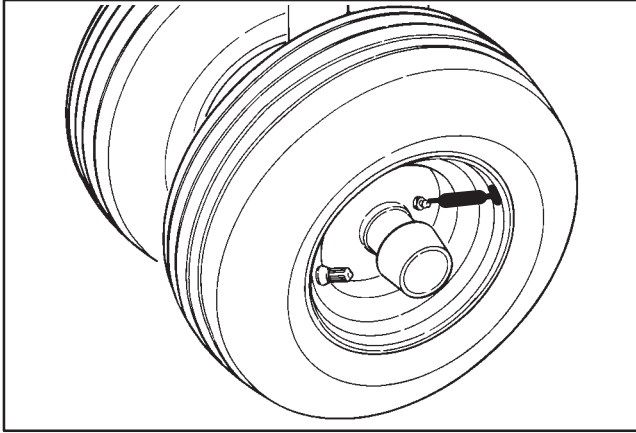

Figure 21

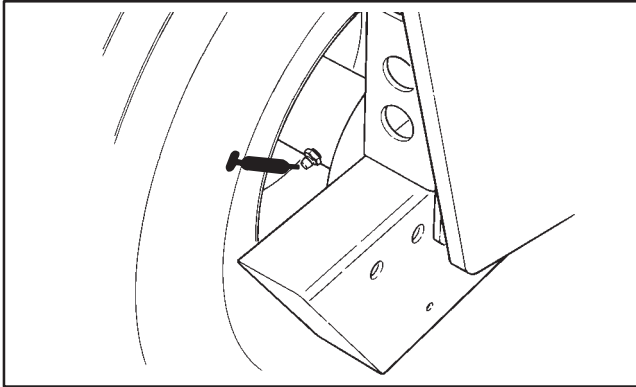

Figure 22

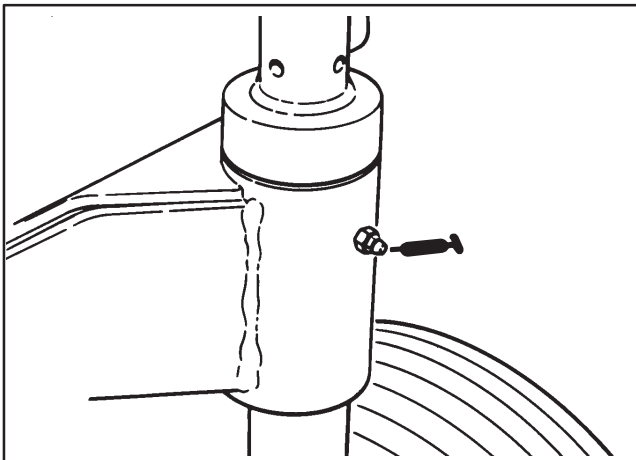

Figure 23

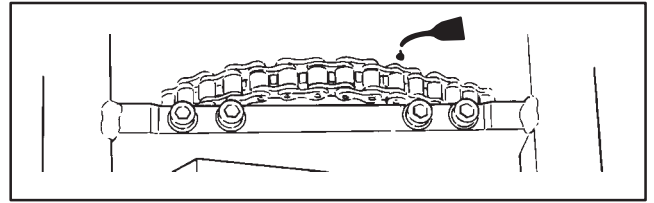

Figure 24

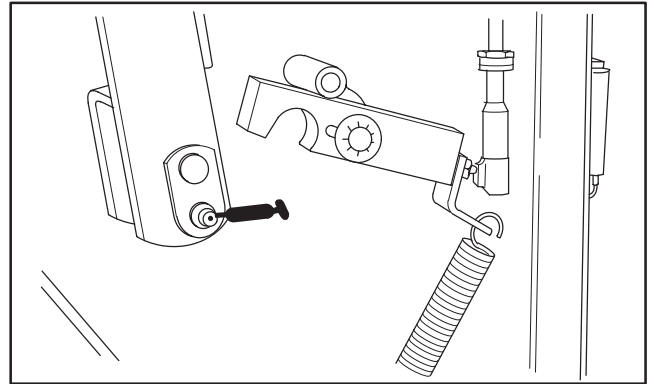

Figure 25

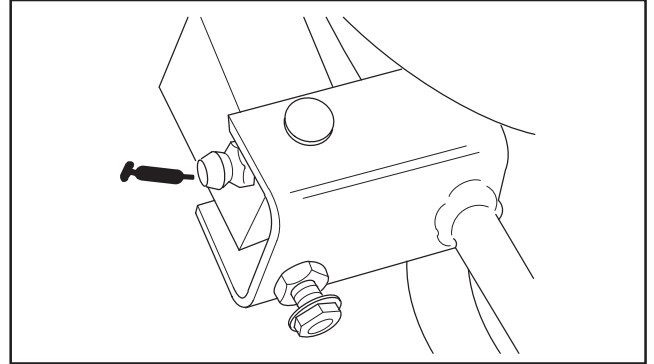

Figure 26

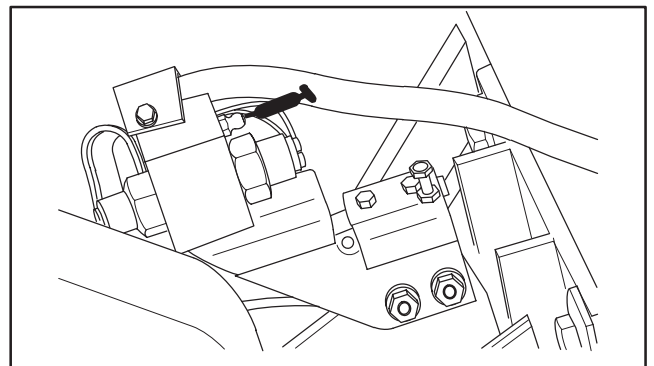
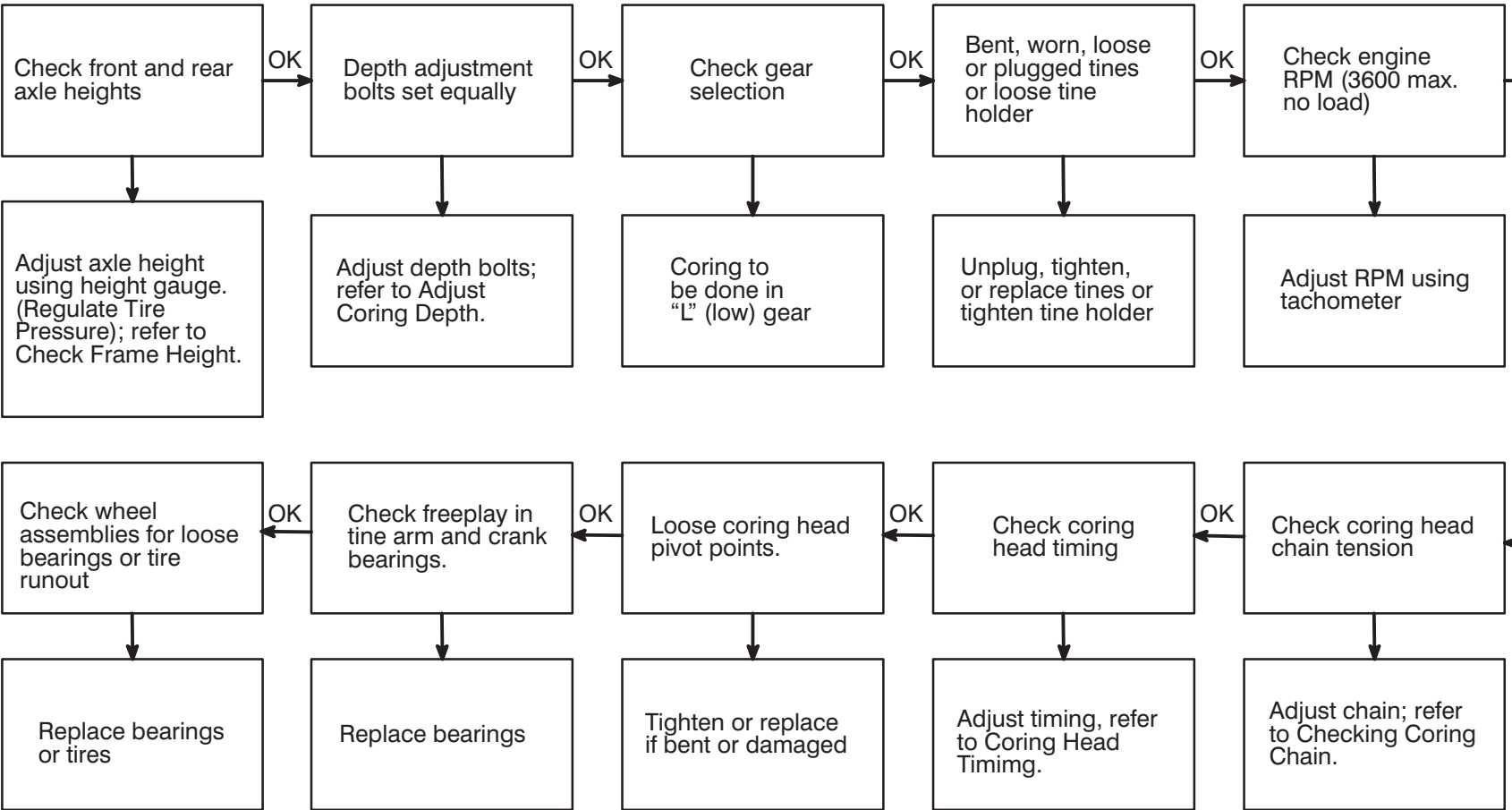

Figure 27

HOLE QUALITY TROUBLE SHOOTING
 (i.e. Hole Depth, Hole Roundness or Turf Tearing)



MAINTENANCE



CAUTION

Before servicing or making adjustments to the machine, stop engine and remove key from the switch.

ENGINE CARE

The Engine Manual supplied with your Greens Aerator provides the maintenance procedures for service of the air cleaner, oil requirements, ignition components, etc.

Note: If Greens Aerator is to be operated at altitudes of 3000 feet or above sea level, it may require a high altitude carburetor main jet. Order Part No. 8055537 from your Authorized Briggs & Stratton Service Dealer.

CHANGING HYDRAULIC SYSTEM OIL

The hydraulic system oil must be changed immediately when any contamination, sludge, water or condensation appears.

1. Remove tines from tine blocks and lower coring head; refer to Install Tines.
2. Position a drain pan under chassis below pump assembly (Fig. 28).
3. Remove hose clamp securing return hose to pump. Disconnect hose from pump allowing oil to flow into drain pan.
4. Connect return hose to pump and secure with hose clamp.

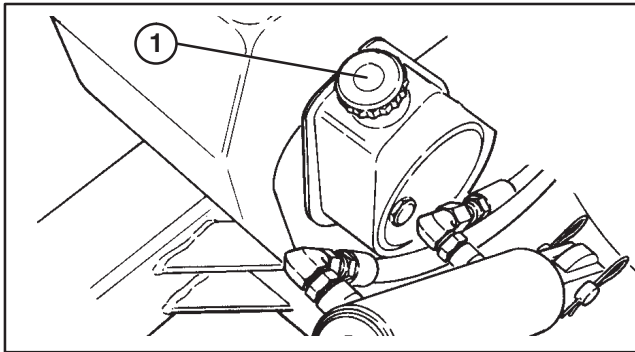

Figure 28

1. Pump reservoir

5. Fill pump reservoir; refer to checking Hydraulic System Fluid.
6. Check all connections for possible leaks.

CHANGE TRANSAXLE OIL

Each year oil in transaxle must be changed. If possible run machine just before changing oil. Warm oil flows more freely and carries more contaminants than cold oil.

1. Place a drain pan below drain plug on axle. Clean area around drain plug (Fig. 29).

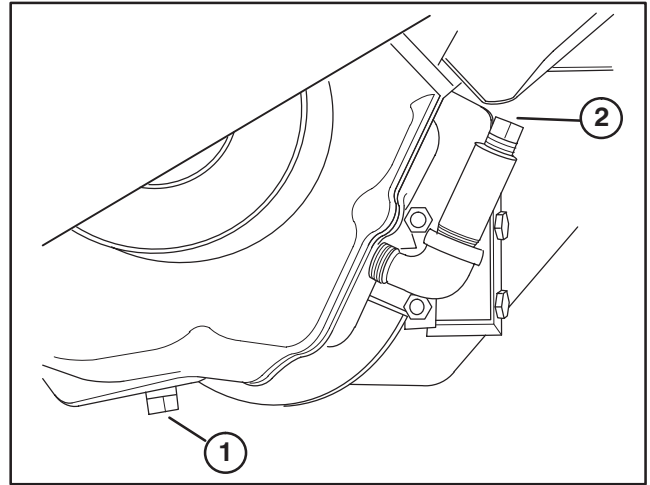

Figure 29

1. Drain plug
2. Fill plug

2. Remove drain plug and allow oil to flow into drain pan. After oil is drained, reinstall drain plug.
3. Remove fill plug (Fig. 29) and pour approx. 64 oz. of SAE E.P. 90 wt. oil into extension tube. Stop when oil level reaches top of tube.
4. To check oil level in the future: remove plug, and add oil as required to bring level to top of tube.

BELT ADJUSTMENTS

Make sure belts are properly tensioned to assure correct operation of unit and unnecessary wear. Check all belts midway in the span of the belt.

1. The belt tension on the hydraulic pump (Fig. 30) must have a maximum deflection of 5/32 of an inch with a 2 to 3 pound load applied.

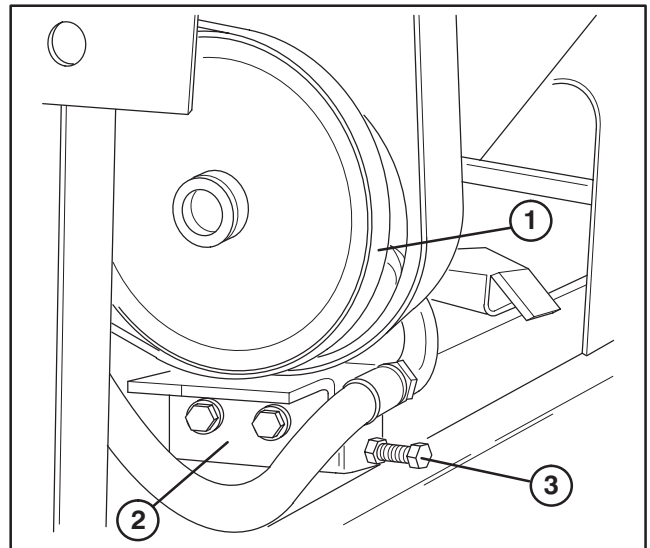

Figure 30

1. Hydraulic pump belt
2. Pump support bracket
3. Adjusting screw

MAINTENANCE

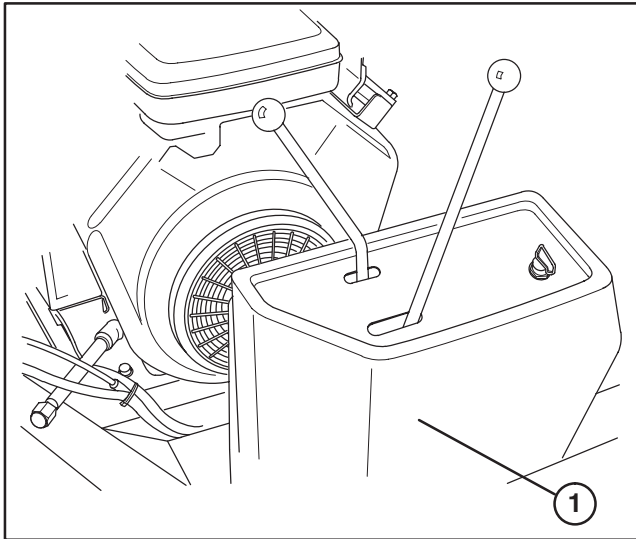

Figure 31
1. Control cover

- A. Remove control cover to expose adjusting screws (Fig. 31).
 - B. To adjust tension, loosen (2) capscrews securing pump support bracket to chassis (Fig. 30).
 - C. Loosen jam nuts on adjusting screw.
 - D. Rotate adjusting screw until desired belt tension is achieved.
 - E. Tighten jam nuts and pump support screws.
 - F. Recheck belt deflection.
 - G. Reinstall control cover.
2. The transaxle belt (Fig. 32) is properly adjusted when there is a gap of 1/4" between drive take up bracket and end of stop bolt, when clutch is engaged.

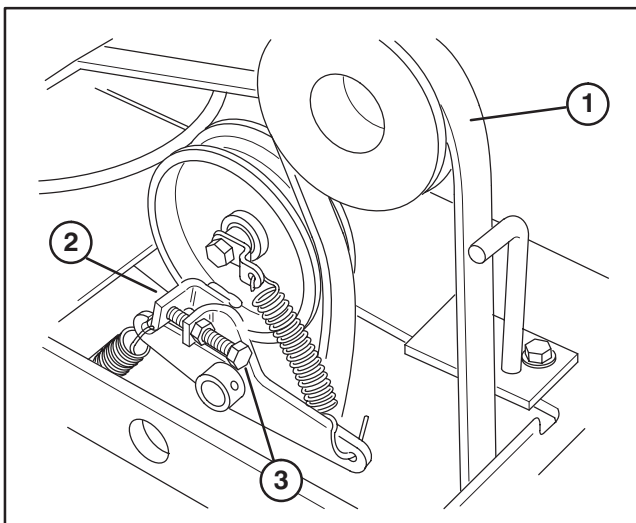

Figure 32
1. Transaxle belt
2. Drive take up bracket
3. Stop bolt

3. If coring head drive belt (Fig. 33) does not properly engage or disengage when entering or exiting the ground, check belt adjustment. Coring head mechanism should begin rotating 1" before tines contact turf.

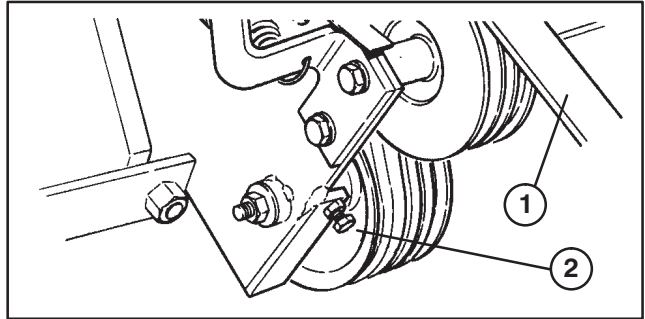

Figure 33
1. Coring head drive belt
2. Adjusting screw

- A. Unlatch and remove coring head cover (Fig. 34).

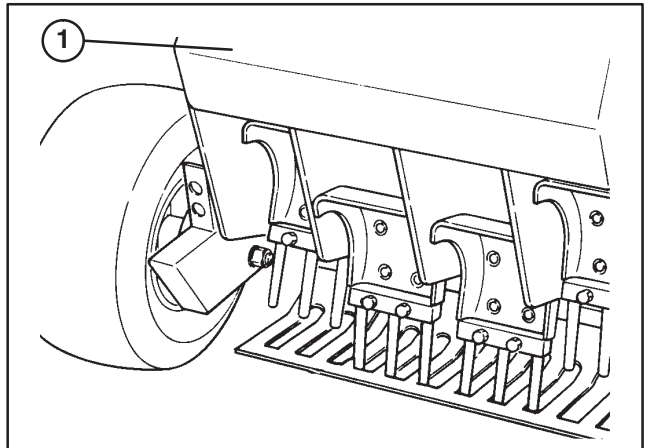

Figure 34
1. Coring head cover

- B. Lower coring head onto lock-up brackets.
- C. Loosen adjusting screw jam nut (Fig. 33) on top of idler pulley bracket.
- D. With engine running at idle speed, rotate adjusting screw (Fig. 33) until coring head just barely starts to creep or stops. Then tighten adjusting screw one more turn. Tighten jam nut.
- E. Stop the engine and loosen adjusting screw jam nut on opposite side of pulley.
- F. Rotate adjusting screw until contact is made, then tighten jam nut.
- G. Reinstall coring head cover and hook latches.

MAINTENANCE

ADJUSTING SERVICE BRAKE

If brake lever (Fig. 35) contacts control handle when brake is applied, an adjustment to the brake cable is required. When the brake is fully applied, the end of the lever should be a minimum of 1/2 inch from control handle.

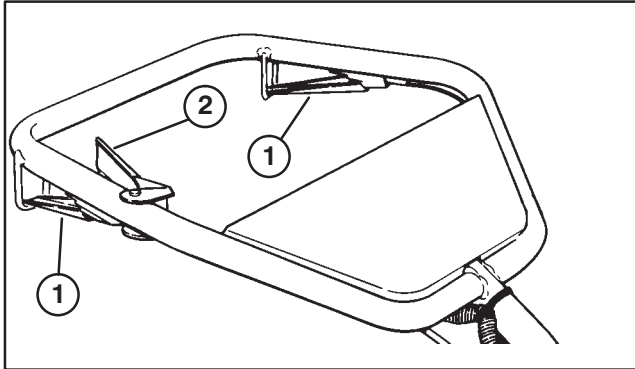

Figure 35

1. Interlock lever switches
2. Service brake

1. Remove screw and nut securing cable clevis to brake lever (Fig. 36).

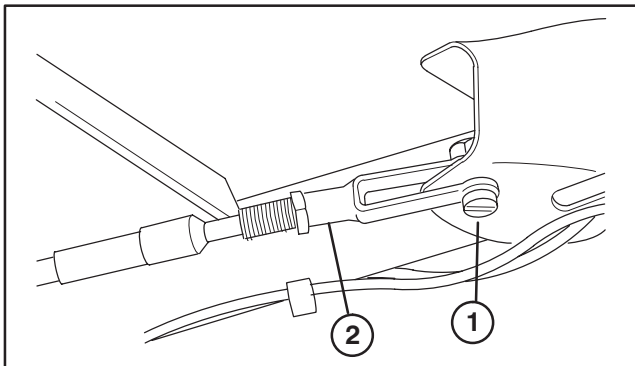

Figure 36

1. Screw and nut
2. Cable clevis

2. Thread cable clevis onto cable as required to attain the 1/2 inch dimension.
3. Reinstall cable clevis to brake lever with screw and nut.
4. Additional adjustment can be attained by loosening jam nut at either end of brake cable conduit and adjusting conduit inboard to tighten cable.

CHECK CORING HEAD CHAINS

After the first 5–10 hours of operation, tension on both coring head chains must be checked and adjusted if required.

1. Depress chain in span between the idler sprocket and upper crank arm sprocket. Applying 8–12 lbs. of force on designated area, chain should deflect approximately .25 inch (Fig. 37)

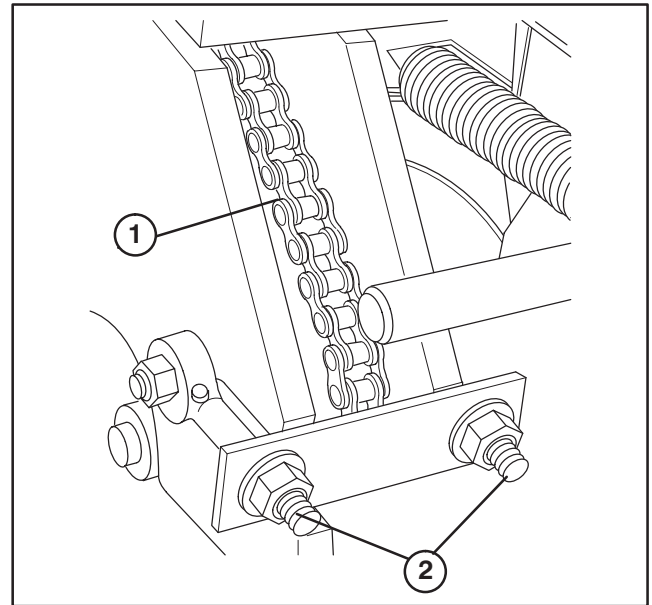

Figure 37

1. Coring head chain
2. Eyebolt nuts

2. Tighten or loosen each eyebolt nut to increase or decrease chain tension. Make sure each eye bolt is adjusted equally (Fig. 37).
3. Check adjustment by repeating previous steps.
4. To make sure eyebolts are adjusted equally, measure distance from center of idler shaft to center of upper crank shaft on both sides of shaft (Fig. 37).
5. Repeat procedure on other chain.

SERVICING ROLLER CHAINS

Cleaning — When cleaning coring head chains, use kerosene, fuel oil or diesel fuel.

Lubrication — Lubricate chains with SAE 30 oil.

Routing — Route chain as shown in figure 38.

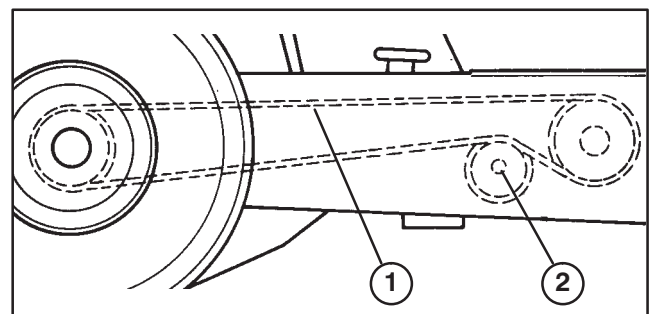

Figure 38

1. Roller chain
2. Idler sprocket

Tensioning — Loosen idler sprocket capscrew, slide sprocket up into chain until firm resistance is felt, then tighten capscrew.

MAINTENANCE

CORING HEAD TIMING

The coring head must be correctly timed to assure proper tine engagement angle and assure proper hole quality.

1. Locate the four (4) timing holes, two (2) on each side of coring head and on crank sprockets (Fig. 39).
2. To check the timing you will need the (4) timing rods, included with unit.
3. Rotate the coring assembly by hand, aligning each of the (4) timing holes so that the timing rods can be inserted through coring head and sprocket.
4. If any of the rods cannot be inserted through the coring head and into sprocket the unit is out of time.
5. To correct timing, locate and remove master link in drive chain.

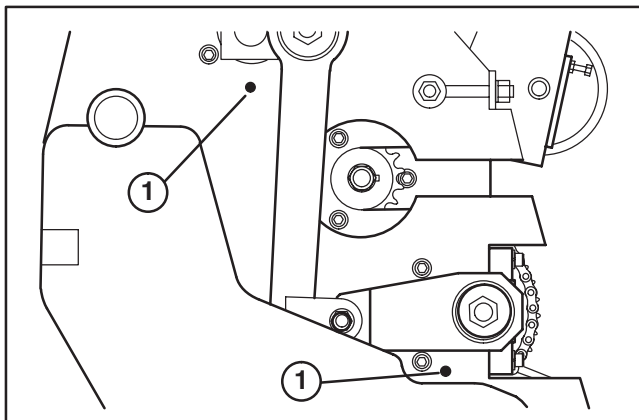

Figure 39
1. Timing holes

6. Rotate the drive sprocket until all timing holes are aligned.
7. Make sure all the rods pass through each of the timing holes and reinstall chain.

REMOVING CORING HEAD

1. Start the engine, raise the coring head and remove tines from tine blocks.
2. Position the coring head lock-up brackets in the down position.
3. Unlatch and remove coring head cover.
4. Remove the coring head drive belt from the engine pulley (Fig. 40).

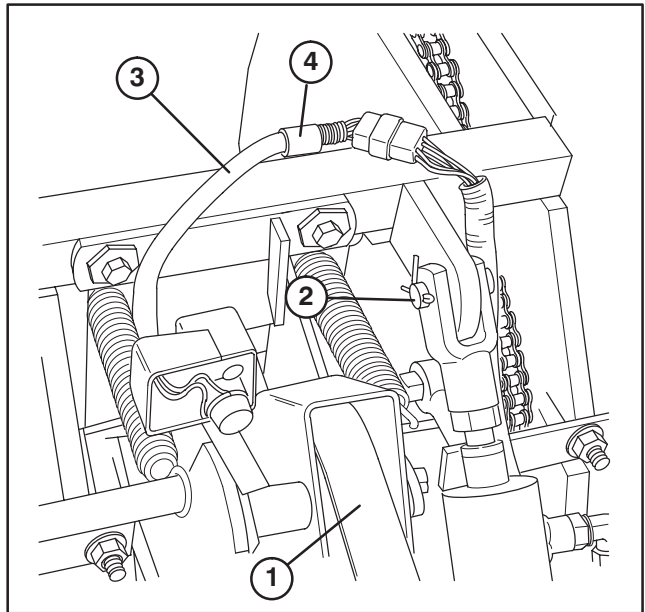

Figure 40

1. Drive belt
2. Lift cylinder pin
3. Wire harness
4. Wire harness clamp

5. Slide coring head stand (optional) under coring head.
6. Lower coring head onto stand.
7. Remove hair pin cotter from lift cylinder pin connected at coring head (Fig. 40), and remove pin.
8. Remove nut securing wire harness clamp to chassis (Fig. 40).
9. Disconnect wire harness from coring head interlock switch.

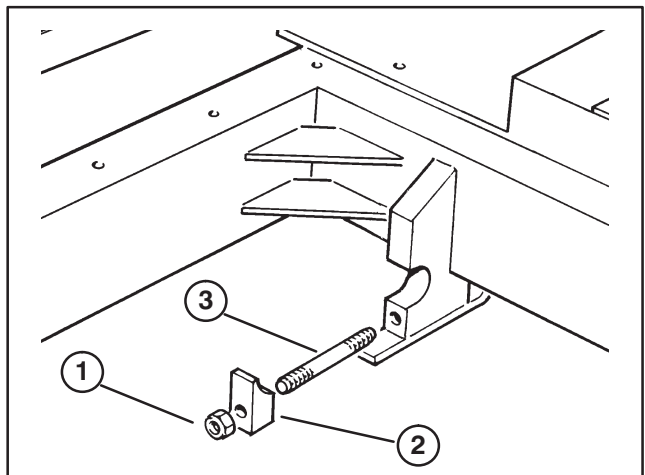

Figure 41

1. Locknut (each side of machine)
2. Clamp
3. Stud

10. Remove (2) locknuts securing coring head to chassis (Fig. 41).
11. Pull traction unit straight away from coring head.
12. Reverse procedure to reinstall coring head.

MAINTENANCE

ADJUSTING BRAKE ASSEMBLY

If the machine does not stop when de-clutching, an adjustment to the brake assembly is required.

1. Engage the clutch lever.
2. Tighten the caliper brake inboard adjustment nut (Fig. 42) until the brake disc cannot be rotated by hand.

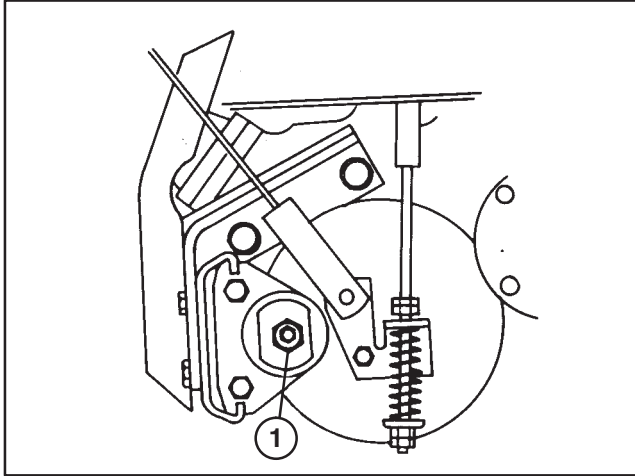

Figure 42

1. Adjusting nut (one on each side)

3. Back the caliper brake nut off until the disc can just be rotated by hand.
4. Disengage the clutch and tighten the outboard nut on the brake.

ADJUSTING CLUTCH SOLENOID

If traction drive lever will not stay engaged, an adjustment to the clutch solenoid may be required.

1. Remove control panel cover (Fig. 43).

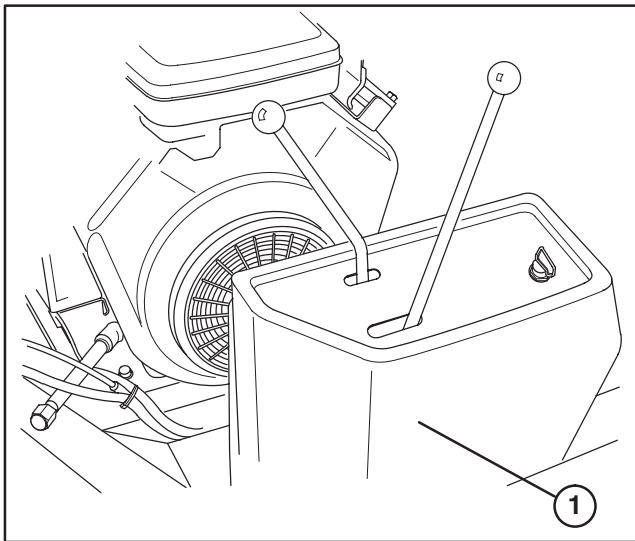

Figure 43

1. Control cover

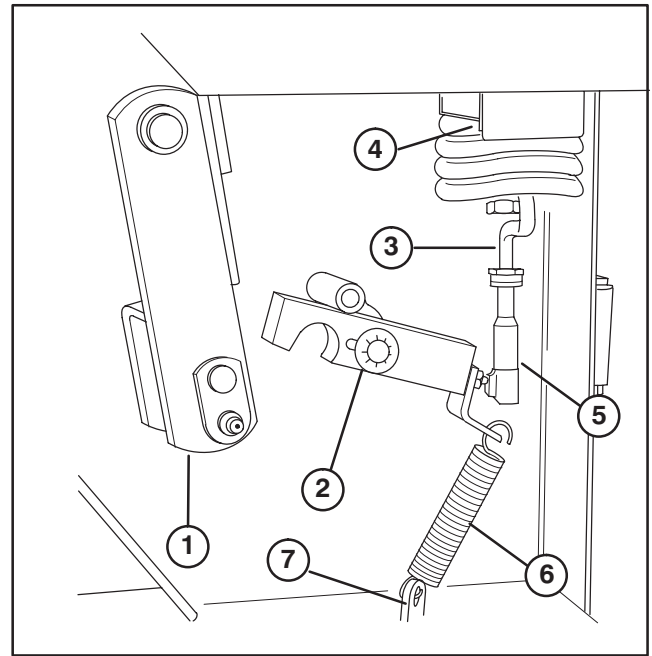

Figure 44

- | | |
|------------------|-------------------|
| 1. Clutch lever | 5. Ball joint |
| 2. Latch | 6. Return spring |
| 3. Adjusting rod | 7. Spring bracket |
| 4. Solenoid | |

2. Turn ignition key to the "ON" position (Do not start engine) and squeeze one of the interlock levers.
3. Check adjustment of solenoid rod. Rod to be adjusted so that when solenoid is energized the latch will engage the clutch lever roller. There should be a small amount of freeplay between the latch and the roller. The solenoid plunger must be fully retracted.

When the solenoid is energized, it should be possible to manually disengage by pushing the clutch lever forward.

When the solenoid is de-energized the latch should release from the clutch lever roller and the traction drive system should de-clutch.

5. If an adjustment to the rod is required, proceed with the following:

- A. Unlock ball joint from latch ball (Fig. 44).
- B. Loosen lock nut and rotate ball joint in or out until desired adjustment is achieved.
- C. Tighten lock nut securely against ball joint.

IMPORTANT: Make sure rod is positioned squarely as shown in Fig. 44.

Note: Make sure there is no tension on return spring when rod is in the disengaged (down) position. Loosen spring bracket capscrew and rotate bracket in or out until spring tension is relieved on spring. Tighten capscrew. Spring is to be hooked on latch from inside out as shown in Fig. 44.

- D. Recheck adjustment and readjust if required.

MAINTENANCE

ADJUSTING THROTTLE CONTROL ROD

If engine speed does not decrease when shifting into reverse or machine speed is too fast in reverse, an adjustment to the throttle control rod may be required.

1. Stop engine and remove key from ignition switch.
2. Check location of throttle control rod. Throttle control rod to be flush with left edge of neutral slot in gear shift plate (Fig. 45).

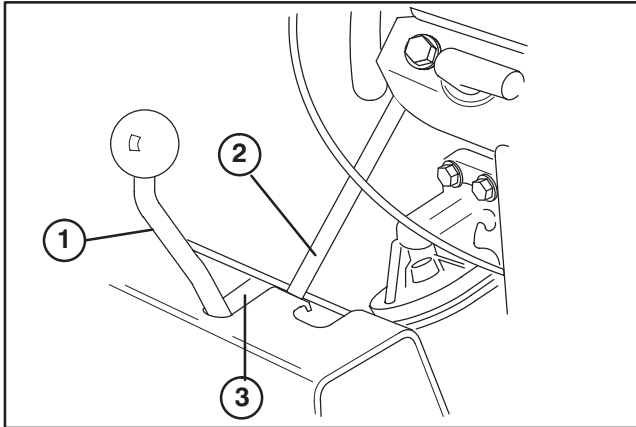

Figure 45

1. Gear shift lever
2. Throttle control rod
3. Neutral slot

3. Adjust throttle control rod as follows:
 - A. Loosen jam nut on control rod pivot bracket adjusting screw (Fig. 46).
 - B. Rotate screw until rod is flush with slot in plate.
 - C. Tighten jam nut.

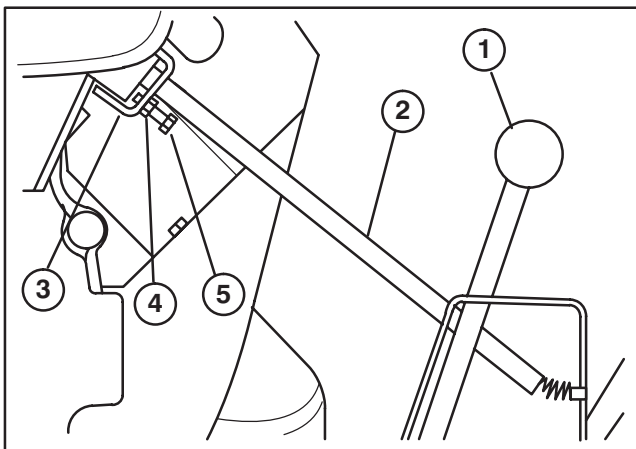

Figure 46

1. Gear shift lever
2. Throttle control rod
3. Control rod pivot bracket
4. Jam nut
5. Adjusting screw

4. Move gear shift lever to neutral and start engine. Move throttle to FAST position (3600 RPM).
5. Move gear shift lever to reverse and check engine RPM. Engine speed to be 1600 ± 200 RPM when in reverse. To adjust engine speed:
 - A. Loosen jam nut on governor arm adjusting screw (Fig. 47).

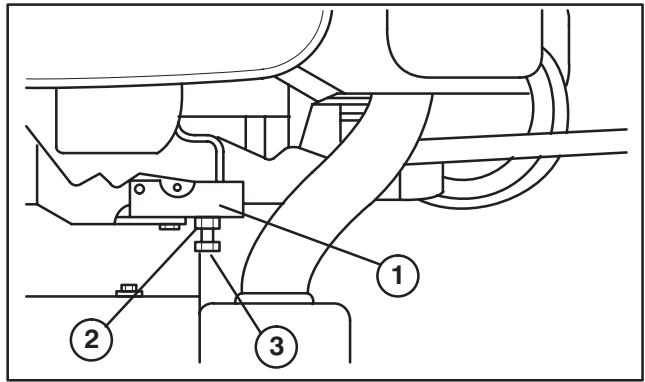

Figure 47

1. Governor arm
2. Jam nut
3. Adjusting screw

- B. Rotate screw until engine speed in reverse is $1600 \text{ RPM} \pm 200 \text{ RPM}$ or as desired.
- C. Tighten jam nut.
- D. Move gear shift lever to neutral position, engine should accelerate to high speed, then shift back to reverse position, engine should slow down. Readjust if required.

BATTERY CARE

1. Battery electrolyte level must be properly maintained and the top of the battery kept clean. If the Aerator is stored in a location where temperatures are extremely high, the battery will run down more rapidly than if the machine is stored in a location where temperatures are cool.
2. Check the electrolyte level every 25 operating hours or, if machine is in storage, every 30 days.
3. Maintain cell level with distilled or demineralized water. Do not fill cells above the bottom of the split ring inside each cell.
4. Keep top of battery clean by washing periodically with a brush dipped in ammonia or bicarbonate of soda solution. Flush the top surface with water after cleaning. Do not remove the fill caps while cleaning.
5. Battery cables must be tight on terminals to provide good electrical contact.
6. If corrosion occurs at terminals, disconnect cables, negative (-) cable first and scrape clamps and terminals separately. Reconnect cables, positive cable first and coat terminals with petroleum jelly.

BATTERY STORAGE

If the machine will be stored more than 30 days, remove the battery and charge it fully. Either store it on the shelf or on the machine. Leave the cables disconnected if stored on the machine. Store the battery in a cool atmosphere to avoid quick deterioration of the charge in the battery.

ELECTRICAL SCHEMATIC

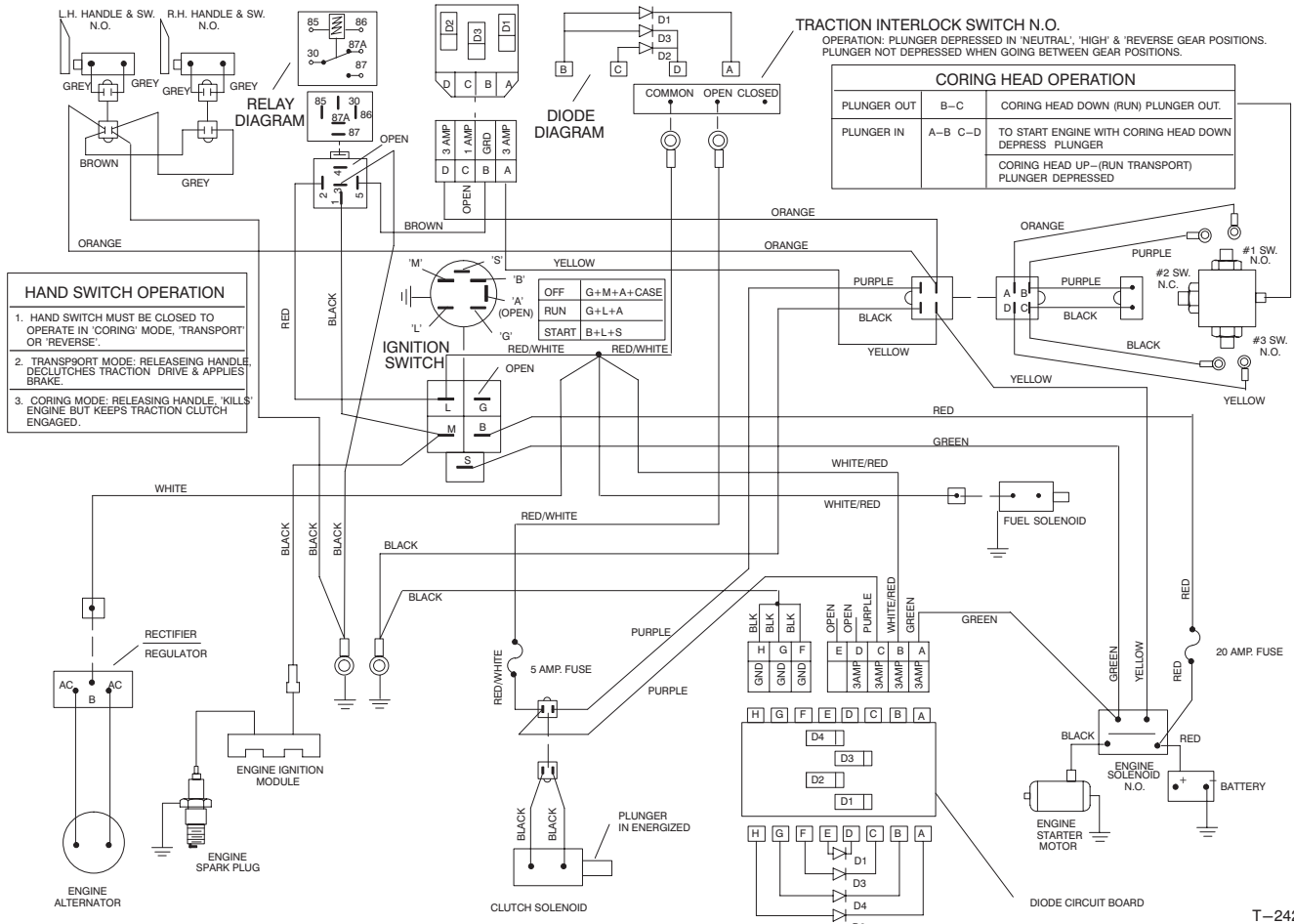

T-2429

HYDRAULIC SCHEMATIC

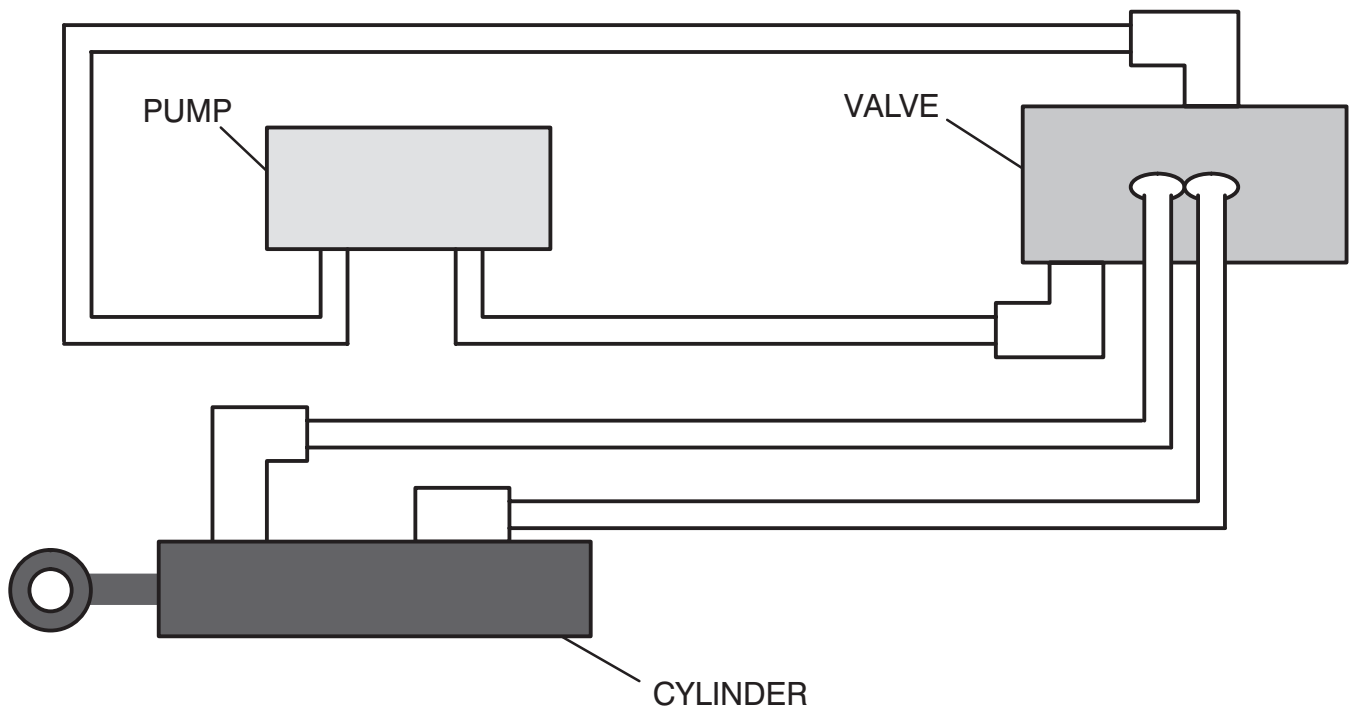

MAINTENANCE SCHEDULE

Minimum Recommended Maintenance Intervals

Maintenance Procedure	Maintenance Interval & Service			
<div style="border: 1px solid black; padding: 2px; margin-bottom: 2px;"> Check Condition of Tines Every 5 hrs Check Engine Oil Level </div> <div style="border: 1px solid black; padding: 2px; margin-bottom: 2px;"> Service Air Filter Pre-Cleaner </div> † Change Engine Oil Service Air Filter Cartridge Lubricate Coring Head Switch Assembly	Every 25 hrs	Every 50 hrs	Every 100hrs	
Change Engine Oil Filter Service Spark Plugs Grease Wheel Bearing Grease Steering Handle Spindle Check Battery Fluid Level Check Battery Cable Connections Check Coring Head Chain Tension Check Hydraulic Pump Belt Tension				
† Initial break in at 8 hours				
<div style="border: 1px solid black; padding: 5px;"> Replace Safety Switches Change Transaxle gear Lubricant Replace Hydraulic Oil Adjust Valves and Torque head Bolts Decarbon Combustion Chamber </div>			Annual Recommendations: Items listed are recommended every 500 hours or 1 year, whichever occurs first.	

IDENTIFICATION AND ORDERING

MODEL AND SERIAL NUMBERS

The GREENS AERATOR traction unit and coring head each have two identification numbers: a model number and a serial number. The two numbers are stamped on a plate which is riveted to each frame member. In any correspondence concerning the GREENS AERATOR, supply model and serial numbers to be sure that correct information and replacement parts are obtained.

To order replacement parts from an authorized TORO Distributor, supply the following information:

1. Model and serial numbers of the machine.
2. Part number, description and quantity of parts desired.

Note: Do not order by reference number if a parts catalog is being used; use the part number.

The Toro Commercial Products Two Year Limited Warranty

The Toro Company warrants your 1996 or newer Toro Hydroject® 3000, Hydroject® 4000, Greens, or Fairway Aerator ("Product") purchased after January 1, 1997, to be free from defects in materials or workmanship for the period of time listed below*. Where a warrantable condition exists, Toro will repair the Product at no cost to you including diagnosis, labor, parts, and transportation. This warranty begins on the date the Product is delivered to the original retail purchaser.

Warranty Duration: Two years or 500 operational hours*, whichever occurs first.

****Contract usage and shared ownership limited to 120 days. *Product equipped with hour meter.**

Owner Responsibilities:

As the Product owner, you are responsible for required maintenance and adjustments stated in your Owner's Manual. Failure to perform required maintenance and adjustments can be grounds for disallowing a warranty claim.

Instructions for Obtaining Warranty Service:

You are responsible for notifying the Commercial Products Distributor or Authorized Commercial Products Dealer from whom you purchased the Product as soon as you believe a warrantable condition exists.

If you need help locating a Commercial Products Distributor or Authorized Dealer, or if you have questions regarding your warranty rights or responsibilities, you may contact us at:

Toro Commercial Products Service Department
8111 Lyndale Avenue South
Minneapolis, MN, 55420-1196
Telephone: (612) 888-8801
Facsimile: (612) 887-8258
E-Mail: Commercial.Service@Toro.Com

Maintenance Parts:

Parts scheduled for replacement as required maintenance ("Maintenance Parts"), are warranted for the period of time up to the scheduled replacement time for that part.

Items/Conditions Not Covered:

Not all product failures or malfunctions that occur during the warranty period are defects in materials or workmanship. The items / conditions listed below are not covered by this warranty:

- Product failures which result from the use of non-Toro replacement parts, or from installation and use of add-on, modified, or unapproved accessories are not covered.
- Product failures which result from failure to perform required maintenance and/or adjustments are not covered.
- Product failures which result from operating the Product in an abusive, negligent or reckless manner are not covered.

- This warranty does not apply to parts subject to consumption through use unless found to be defective. Examples of parts which are consumed, or used up, during normal Product operation include, but are not limited to, blades, reels, bedknives, tines, spark plugs, castor wheels, tires, filters, belts, etc.
- This warranty does not apply to failures caused by outside influence. Items considered to be outside influence include, but are not limited to, weather, storage practices, contamination, use of unapproved coolants, lubricants, additives, or chemicals, etc.
- This warranty does not apply to normal "wear and tear" items. Normal "Wear and Tear" includes, but is not limited to, damage to seats due to wear or abrasion, worn painted surfaces, scratched decals or windows, etc.

Other Legal Disclaimers:

The above remedy of product defects through repair by an authorized distributor or dealer is the purchaser's sole remedy for any defect. This warranty gives you specific legal rights, and you may also have other rights which vary from state to state.

Except for the Emissions warranty referenced below, if applicable, there is no other express warranty. All implied warranties of merchantability and fitness for use are limited to the duration of the express warranty.

Some states do not allow limitations on how long an implied warranty lasts, so the above limitation may not apply to you.

The Toro Company is not liable for indirect, incidental or consequential damages in connection with the use of the Product, including any cost or expense of providing substitute Product or service during periods of malfunction or non-use.

Some states do not allow the exclusion of incidental or consequential damages, so the above exclusion may not apply to you.

Note to California residents: The Emissions Control System on your Product may be covered by a separate warranty meeting requirements established by the U.S. Environmental Protection Agency (EPA), or the California Air Resources Board (CARB). The hour limitations set forth above do not apply to the Emissions Control System Warranty. Refer to the California Emission Control Warranty Statement printed in your Owner's Manual or contained in the engine manufacturer's documentation for details.