



MODEL NO. 30822—200000001 & UP

OPERATOR'S
MANUAL**27" (68.5 mm) ROTARY CUTTING DECK**
For Groundsmaster® 3500 Traction Unit

To understand this product, and for safety and optimum performance, read this manual before starting operation. Pay special attention to **SAFETY INSTRUCTIONS** highlighted by this symbol—



The safety alert symbol means **CAUTION**, **WARNING** or **DANGER**—personal safety instruction. Failure to comply with the instruction may result in personal injury.



Contents

Contents	2
Forward	2
Safety	3
Specifications	6
Before Operating	7
Adjust The Carrier Frame	7
Adjust Height Of Cut	7
Adjust The Roller Scraper	8
Install The Mulching Baffle (Optional)	8
Operating	10
Operating Tips	10
Maintenance	11
Lubrication	11
Cutting Deck Service Latch	11
Separating the Cutting Decks from the Traction Unit	11
Mounting the Cutting Decks to the Traction Unit	12
Blade Plane	12
Inspecting the Blade Plane	12
Adjusting the Blade Plane	13
Removing the Cutter Blade	13
Inspecting and Sharpening the Blade	14
Blade Stopping Time	15
Servicing the Rear Roller	15
Servicing the Front Roller	16
Cutting Deck Storage	17
Model and Serial Numbers	17

Forward

The 27-inch (69cm) rotary cutting deck has advanced concepts in engineering, design and safety; and if maintained properly, will give excellent service.

Since this is a high-quality product, Toro is concerned about the future use of the machine and safety of the user. Therefore, read this manual to familiarize yourself with proper set-up, operation and maintenance instructions.

Certain information in this manual is emphasized. DANGER, WARNING and CAUTION identify personal safety related information. IMPORTANT identifies mechanical information demanding special attention. Be sure to read this directive because it deals with the possibility of damaging a part or parts of the machine. NOTE identifies general information worthy of special attention.

Safety

The Groundsmaster 3500-D was tested and certified by TORO for compliance with the B71.4-1999 specifications of the American National Standards Institute. Although hazard control and accident prevention partially are dependent upon the design and configuration of the machine, these factors are also dependent upon the awareness, concern, and proper training of the personnel involved in the operation, transport, maintenance, and storage of the machine. Improper use or maintenance by the operator or owner of the machine can result in injury. To reduce the potential for any injury, comply with the following safety instructions.

Supervisor's Responsibilities

1. Make sure operators are thoroughly trained and familiar with the operator's manual and all the labels on the machine.
2. Be sure to establish your own special procedures and work rules for unusual operating conditions (e.g., slopes too steep for machine operation. Survey the complete mowing site to determine the hills on which the machine can be safely operated. When performing this site survey, always use common sense and take into consideration the turf condition and the rollover risk.

To determine which hills or slopes on which the machine may be safely operated, use the inclinometer provided with each machine. To perform a site survey, lay a 1.25 meter board on the slope surface and measure the angle of the slope. The board will average the slope but will not take into consideration dips or holes. **THE MAXIMUM SIDE HILL ANGLE SHOULD NOT BE GREATER THAN 25 DEGREES.**

Before Operating

3. Operate the machine only after reading and understanding the contents of this manual and viewing the operator's training video supplied with the machine. A free replacement manual is available by sending complete model and serial number to:

The Toro Company
8111 Lyndale Ave. S.
Bloomington, MN 55420-1196.

4. Only trained operators, skilled in slope operation and who have read this manual and viewed the operator's training video should operate the machine. Never allow children to operate the machine or adults to operate it without proper instructions.
5. Become familiar with the controls and know how to stop the machine and engine quickly.
6. Do not carry passengers on the machine. Keep everyone, especially children and pets, away from the areas of operation.
7. Keep all shields, safety devices and decals in place. If a shield, safety device or decal is damaged, malfunctioning or illegible, repair or replace it before operating the machine.
8. Always wear substantial shoes. Do not operate machine while wearing sandals, tennis shoes or sneakers. Do not wear loose fitting clothing because it could get caught in moving parts and possibly cause personal injury.
9. Wearing safety glasses, safety shoes, long pants and a helmet is advisable and required by some local ordinances and insurance regulations.
10. Make sure the work area is clear of objects which might be picked up and thrown by the blades.
11. Fill fuel tank with diesel fuel before starting engine. Avoid spilling any fuel. Since fuel is highly flammable, handle it carefully.
 - A. Use an approved fuel container.
 - B. Do not remove cap from fuel tank when engine is hot or running.
 - C. Do not smoke while handling diesel fuel.
 - D. Fill fuel tank outdoors and not over one inch from the top of the tank, (bottom of the filler neck). Do not overfill.

While Operating

12. Always wear your seat belt.
13. Do not run the engine in a confined area without adequate ventilation. Exhaust fumes

are hazardous and could be deadly.

14. Sit on the seat when starting and operating the machine.
15. Check interlock switches daily for proper operation (Refer To *Checking Interlock Switches*). Do not rely entirely on safety switches -shut off engine before getting off seat. If a switch fails, replace it before operating the machine. The interlock system is for your protection, so do not bypass it. Replace all interlock switches every two years.
16. The operator must be skilled and trained in how to drive on hillsides. Failure to use caution on slopes or hills may cause vehicle to tip or roll, possibly resulting in personal injury or death.
17. This triplex mower has a unique drive system for superior traction on hills. The uphill wheel will not spin out and limit traction like conventional triplexes. If operated on a side hill that is too steep, rollover may occur before losing traction.
18. Before backing up, look to the rear and assure no one is behind the machine. Watch out for traffic when near or crossing roads. Always yield the right of way.
19. Keep hands, feet and clothing away from moving parts and the mower discharge area.
20. The slope angle at which the machine will tip is dependent on many factors. Among these are mowing conditions such as wet or undulating turf, speed (especially in turns), position of the cutting units (with sidewinder), tire pressure and operator experience. At side hill slope angles of 20 degrees or less the risk of a rollover is low. As the slope angle increases to a Toro recommended maximum limit of 25 degrees the risk of a rollover increases to a moderate level. **DO NOT EXCEED A 25 DEGREE SIDE HILL ANGLE BECAUSE THE RISK OF A ROLLOVER AND SERIOUS INJURY OR DEATH IS VERY HIGH.** The Groundsmaster 3500-D is equipped with an angle indicator, mounted on the steering tube, which indicates the side hill angle the machine is operating on and identifies

the recommended maximum limit of 25 degrees.

Stay alert for holes in terrain and other hidden hazards which can cause a sudden change in side hill angle. Use extreme caution when operating close to sand traps, ditches, creeks, steep hillsides or other hazards. Reduce speed when making sharp turns. Do not turn on hills. Avoid sudden stops and starts. Use reverse pedal for braking. Cutting units must be lowered when going down slopes for steering control.

21. When starting the engine:
 - A. Engage parking brake.
 - B. Be sure traction pedal is in neutral and blade drive is in disengage position.
 - C. After engine starts, release parking brake and keep foot off traction pedal. Machine must not move. If movement is evident, the neutral control linkage is incorrectly adjusted: therefore, shut engine off and adjust until machine does not move when traction pedal is released. Refer to *Adjusting Transmission for Neutral*.
22. This product may exceed noise levels of 85 dB(A) at the operator position. Ear protectors are recommended for prolonged exposure to reduce the potential of permanent hearing damage.
23. Raise the cutting units when driving from one work area to another.
24. Do not touch engine, muffler, exhaust pipe or hydraulic tank while engine is running or soon after it has stopped because these areas could be hot enough to cause burns.
25. If a cutting unit strikes a solid object or vibrates abnormally, stop immediately. Turn engine off, wait for all motion to stop and inspect for damage.
26. Before getting off the seat:
 - A. Move traction pedal to neutral.
 - B. Set the parking brake.
 - C. Disengage the cutting units and wait for the

blades to stop spinning.

- D. Stop the engine and remove key from the ignition switch.

27. Whenever machine is left unattended, make sure, key is removed from ignition switch and parking brake is set.

Maintenance

28. Before servicing or making adjustments to the machine, stop the engine and remove key from switch to prevent accidental starting of the engine.
29. Check performance of all interlock switches daily. Do not defeat interlock system. It is for your protection. 30. To ensure entire machine is in good operating condition, frequently check and keep all nuts, bolts, screws and hydraulic fittings tight.
31. Make sure all hydraulic line connectors are tight, and all hydraulic hoses and lines are in good condition before applying pressure to the system.
32. Keep body and hands away from pin hole leaks or nozzles that eject hydraulic fluid under high pressure. Use paper or cardboard, not hands, to search for leaks. Hydraulic fluid escaping under pressure can have sufficient force to penetrate skin and do serious damage. If fluid is injected into the skin it must be surgically removed within a few hours by a doctor familiar with this form of injury or gangrene may result. 33. Before disconnecting or performing any work on the hydraulic system, all pressure in system must be relieved by stopping engine and lowering cutting units to the ground.
34. If major repairs are ever needed or if assistance is desired, contact an Authorized Toro Distributor.
35. To reduce potential fire hazard, keep the engine area free of excessive grease, grass, leaves and accumulation of dirt.
36. If the engine must be running to perform a maintenance adjustment, keep hands, feet,

clothing, and any other parts of the body away from the cutting units and any moving parts. Keep everyone away.

37. Do not overspeed the engine by changing governor settings. To assure safety and accuracy, have an Authorized Toro Distributor check maximum engine speed with a tachometer.
38. Engine must be shut off before checking oil or adding oil to the crankcase.
39. To insure optimum performance and safety, use genuine TORO replacement parts and accessories. Replacement parts and accessories made by other manufacturers could be dangerous, and such use could void the product warranty of The Toro Company.

Specifications

Chamber Construction: Welded 10- and 12-gauge steel. Spindle support withstands multiple blade impact tests. Deck frame withstands collisions.

Blade: Heat-treated steel.

Tip Speed: 16,300 ft./min. nominal.

Blade Plane:	(Factory pre-set)
Height of Cut	2.00 (5.08 cm)
Right or left side	2.15 (5.46 cm)
Side to side	Within 0.08 cm) of each other
Blade rake	Approximately 5/16 in. (0.79 cm)

Height of Cut: 3/4–4 inches (1.91–10.16 cm) in 1/4 inch (.64 cm) Increments.

Deck Drive: Hydraulic, closed-loop, integrated relief. High-efficiency balanced gear-type pump. High-efficiency balanced gear-type motor. Double six row single-pass cooler which tilts out for cleaning. Recommended Oil is Mobil DTE 15M (Mobil EAL biodegradable compatible).

Spindles: 1-1/4 in. (3.17 cm) shaft, greaseable, tapered roller bearing, ductile iron housing, which withstands multiple impact tests.

Discharge: Rear; even clipping distribution in wet or dry conditions.

Mulching Baffle (Optional): Pre-drilled mounting holes provided in decks.

Front Rollers: Two 5 in. (12.7 cm) diameter, ductile iron w/ hollow core, sealed bearings, close location to the blade.

Rear Roller: One 3 inch (7.6 cm) diameter, steel, sealed bearings, exterior shaft seal, full length, close location to the blade.

Cup: 6 inch (15.2 cm) standard.

Roller Scraper: 1/4 inch (0.64 cm) high strength square rod, located below the center line, tensioned for consistent gap.

Dimensions:

Overall length 33.8 in. (85.8 cm)

Overall width 34.0 in. (86.4 cm)

Overall height 9.6 in. (24.4 cm) to carrier mount

10.5 in. (26.7 cm) at 3/4 in. height of cut

13.75 in. (34.9 cm) at 4 in. height of cut

Roller footprint

Front to back 29.3 inch (74.4 cm)

Rear Roller 29.8 inch (75.7 cm) full length

Front Rollers 18.5 inch (47.0 cm) between front rollers

Suspension: Non steering carrier frame.

Weight: 190 lbs. (86 kg)

Certification: Complies with ANSI B71.4-1999 and European Community (CE) with required rear ballast.

Accessories:

Mulching baffle kit Model No. 30824
(Kit contains parts for three decks)

Specifications and design subject to change without notice.

Before Operating

To prevent accidental starting of the engine, while performing maintenance, shut off the engine and remove the key from the ignition switch.

Adjust The Carrier Frame (Fig. 1)

The front and rear cutting decks require different mounting positions.

The front cutting deck has two mounting positions, depending on what height of cut and degree of deck rotation is desired. The rear cutting deck has one mounting position for proper alignment with the cutting unit under the frame.

Front Cutting Decks

1. For heights of cut in the 1.9–7.6cm (3/4- to 3-inch) range, the front carrier frames should be mounted in the lower front mounting holes.

Note: This permits more up travel of the cutting decks relative to tractor when approaching quick uphill changes in terrain. It does, however, limit the clearance of the chamber to the carrier when cresting sharp knolls.

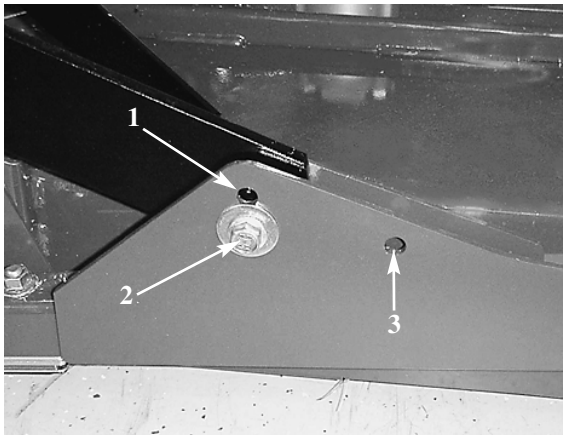

Figure 1

1. Front deck mounting hole (upper)
2. Front deck mounting hole (lower)
3. Rear deck mounting hole

2. For heights of cut in the 6.3–10.2cm (2-1/2–4-inch) range, the front carrier frames should be mounted in the upper front mounting holes.

Note: This increases the chamber-to-carrier

clearance due to the higher position of the cutting chamber, but will cause the cutting decks to reach their maximum up travel sooner.

Rear Cutting Decks

1. For all heights of cut, the rear cutting deck should be mounted in the rear mounting holes.

Adjust Height Of Cut (Fig. 2–3)

IMPORTANT. This cutting deck often cuts approximately 6mm lower than a reel cutting unit with the same bench setting. It may be necessary to have this rotary cutting decks set 6mm above that of reels cutting in the same area.

1. Lower the cutting deck to the ground, stop the engine and remove the key from the ignition switch.
2. Loosen the capscrew securing each height-of-cut bracket to the height-of-cut plate (Front and each side).
3. Beginning with the front adjustment, remove the capscrew.

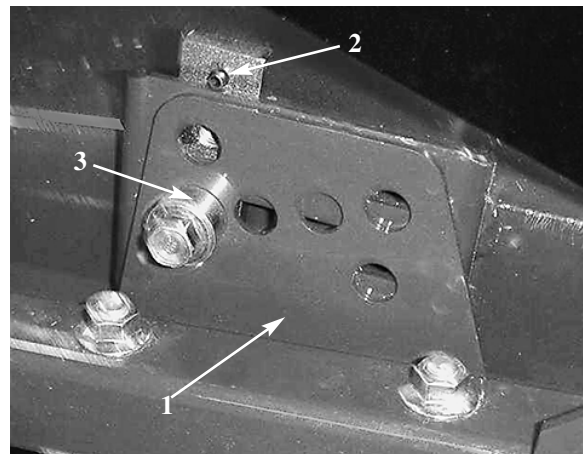

Figure 2

1. Height-of-cut bracket
2. Height-of-cut plate
3. Spacer

4. While supporting the chamber, remove the spacer.
5. Move the chamber to desired height of cut, install the spacer into designated height-of-cut

hole and slot.

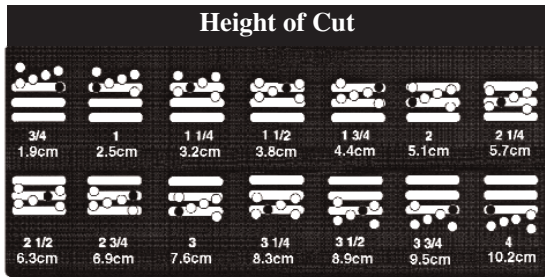

Figure 3

6. Position the taped plate in line with the spacer.
7. Install the capscrew finger tight.
8. Repeat steps 4–7 for each side adjustment.
9. Tighten all three capscrews; to 30 ft-lb. (41 N•m).

NOTE: Adjustments of more than 3.8cm may require temporary assembly to an intermediate height to prevent binding (e.g. changing from 3.2cm to 6.9cm height of cut).

Adjust The Roller Scraper (Fig. 4)

The rear roller scraper is designed to work best when there is an even gap of 0.51–1.02mm between the scraper (square rod) and roller, with relatively high tension in the rod.

1. Loosen the locknut securing one end of the roller scraper rod to the mounting bracket (Fig. 4). There should be approximately 0.13–0.51mm end play in the loosened rod.

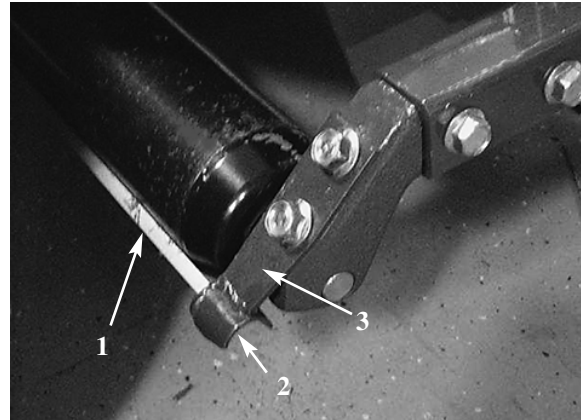

Figure 4

1. Roller scraper
2. Locknut
3. Mounting bracket

2. Loosen the left and right scraper bracket mounting screws until the mounting brackets can be adjusted with a light tap.
3. Slide the scraper brackets up or down until a gap of 0.51–1.02mm is achieved between the rod and the roller.
4. Secure the mounting screws to 30 ft-lb. (41 N•m).
5. Tighten the scraper rod lock nut to 65 in-lb. (8.5 N•m).

NOTE: If one side of the scraper rod becomes worn, it can be rotated in the mounting brackets 180 degrees for a new edge.

Install The Mulching Baffle (Fig. 5) (Optional)

1. Thoroughly clean debris from the mounting holes on the rear wall and left side wall of the chamber.
2. Install the mulching baffle in the rear opening and secure it with (5) flange head screws.

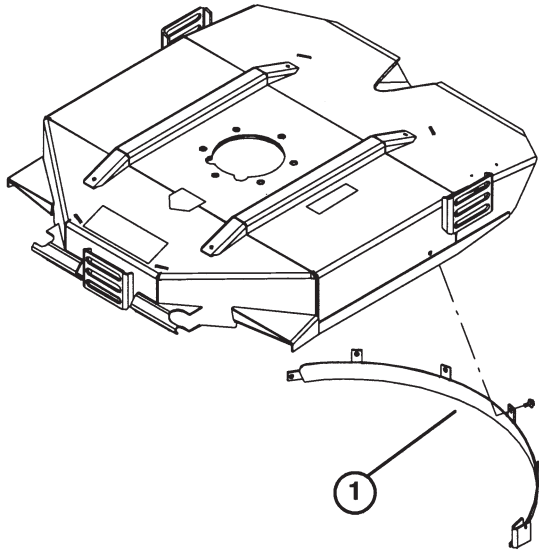

Figure 5

1. Mulching baffle

3. Verify that the mulching baffle does not interfere with either the tip of the blade and does not protrude inside the surface of the rear chamber wall.

Operating

Operating Tips

- 1. MOW WHEN GRASS IS DRY**—Mow either in the late morning to avoid the dew, which causes grass clumping, or in late afternoon to avoid the damage that can be caused by direct sunlight on the sensitive, freshly mowed grass.
- 2. SELECT THE PROPER HEIGHT-OF-CUT SETTING TO SUIT CONDITIONS** — Remove approximately 2.5cm or no more than 1/3 of the grass blade when cutting. In exceptionally lush and dense grass, you may have to raise your height-of-cut setting another notch.
- 3. ALWAYS START MOWING WITH SHARP BLADES**—A sharp blade cuts cleanly and without tearing or shredding the grass blades . Tearing and shredding causes the grass to turn brown at the edges which impairs growth and increases susceptibility to diseases. Make sure the blade is in good condition and a full sail is present.
- 4. CHECK THE CONDITION OF THE DECK**— Make sure the cutting chambers are in good condition. Straighten any bends in the chamber components to assure correct blade tip/chamber clearance.

CAUTION: This product may exceed noise levels of 85 dB(A) at the operator position. Ear protectors are recommended for prolonged exposure to reduce the potential of permanent hearing damage.
- 5. AFTER OPERATING**—To assure optimum performance, clean the underside of the mower housing. If residue is allowed to build up in the mower housing, cutting performance will decrease.

Maintenance

Lubrication (Fig. 6)

Each cutting deck has two grease fittings per spindle. Either fitting can be used, whichever is more accessible. If the machine is operated under normal conditions, lubricate the blade spindle bearings (Fig. 6) with No. 2 general purpose lithium base grease or molybdenum base grease, after every 50 hours of operation. Pump grease into the fitting until a small amount appears at bottom of the spindle housing (under the deck).

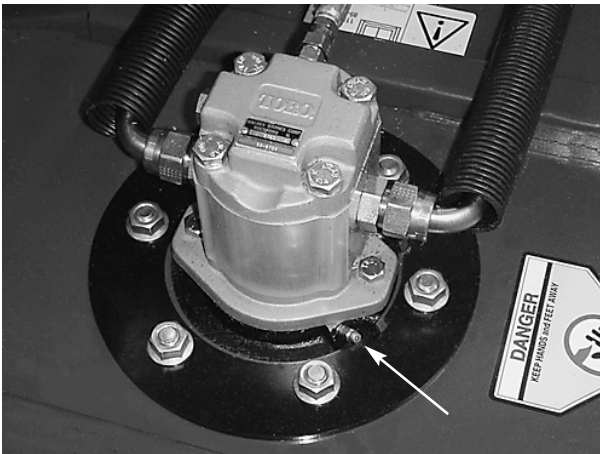

Figure 6

To prevent accidental starting of the engine while performing maintenance, shut off the engine and remove the key from the ignition switch.

Cutting Deck Service Latch (Fig. 7)

When servicing cutting decks, use the service latch to prevent injury.

1. Center the cutting deck with the traction unit.
2. Raise the cutting decks to the transport position.
3. Set the parking brake and turn off the machine.
4. Release the latch rod from the front carrier frame retainer.

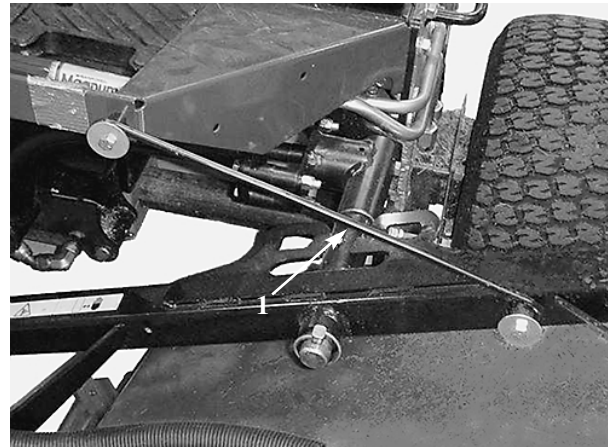

Figure 7

1. Service latch hook

5. Lift the outside of the front cutting decks and place the latch over frame pin mounted on the front of operators platform.
6. Release the latch rod from the rear carrier frame retainer.
7. Hook the latch over the frame pin on the left side of the machine.
8. Sit on the operator seat and start the traction unit.
9. Lower the cutting decks to the mow position.
10. Turn off the machine and remove the key.
11. Reverse procedure to unlatch the cutting decks.

Separating The Cutting Decks From The Traction Unit (Fig. 8–9)

1. Position the machine on level surface, lower the cutting decks to the floor, shut off the engine and engage the parking brake.
2. Disconnect and remove the hydraulic motor from the deck. Cover the top of the spindle to prevent contamination.

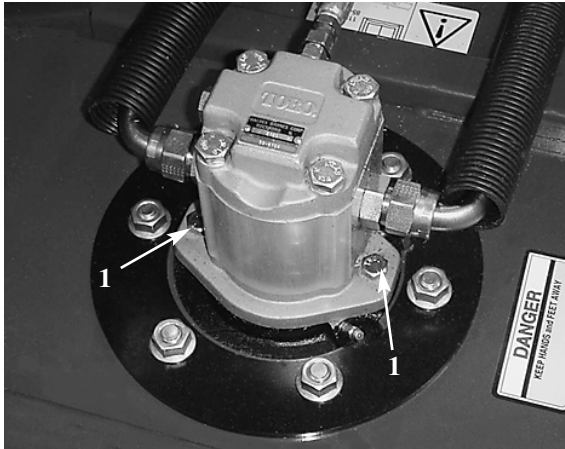

Figure 8

1. Motor mounting screws

3. Remove the lynch pin securing the deck carrier frame to the lift arm pivot pin.

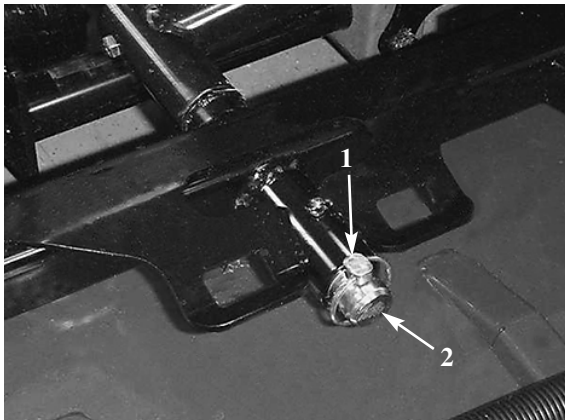

Figure 9

1. Lynch pin
2. Lift arm pivot pin

4. Roll the cutting deck away from the traction unit.

Mounting The Cutting Decks To The Traction Unit

1. Position the machine on a level surface and shut off the engine.
2. Move the cutting deck into position in front of the traction unit.
3. Slide the deck carrier frame onto the lift arm pivot pin. Secure it with a lynch pin.
4. Install the hydraulic motor to the deck. Make

sure the O- ring in is position and not damaged.

5. Grease the spindle.

Blade Plane

The rotary deck comes from the factory preset at 5.1cm height of cut and blade rake of 0.70cm. The left and right hand heights are also preset to within ± 0.79 mm of the other.

The cutting deck is designed to withstand blade impacts without deformation of the chamber. If a solid object is struck, inspect the blade for damage, and the blade plane for accuracy

Inspecting The Blade Plane (Fig. 10)

1. Remove the hydraulic motor from the cutting deck and remove the cutting deck from the tractor.
2. Use a hoist (or minimum of two people) and place the cutting deck on a flat table.
3. Mark one end of the blade with a paint pen or marker. Use this end of the blade to check all heights.
4. Position the cutting edge of marked end of the blade at 12 o'clock (straight ahead in the direction of mowing) and measure height from the table to the cutting edge of the blade.

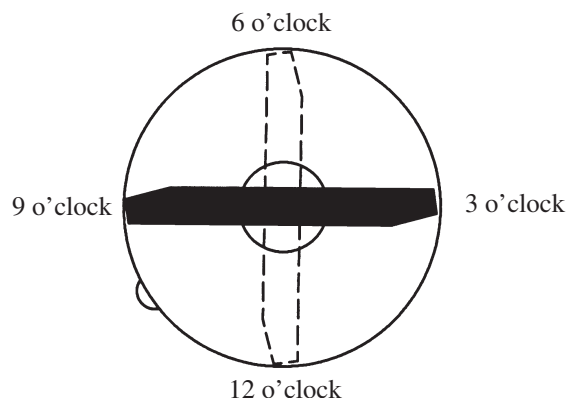

Figure 10

5. Rotate the marked end of the blade to the 3 and 9 o'clock positions and measure heights.
6. Compare 12 o'clock measured height to the height-of-cut setting. It should be within 0.76mm. The 3 and 9 o'clock heights should be $0.38 \pm 0.76\text{cm}$ higher than the 12 o'clock setting and within 0.76cm of each other.

If any of these measurements are not within specification, proceed to Adjusting *The Blade Plane*.

Adjusting The Blade Plane (Fig. 11)

Start with the front adjustment (change one bracket at a time).

1. Remove the height-of-cut bracket, (front, left or right) from the deck frame.
2. Adjust 0.152cm shims and/or 0.76cm shim between the deck frame and bracket to achieve the desired height setting.

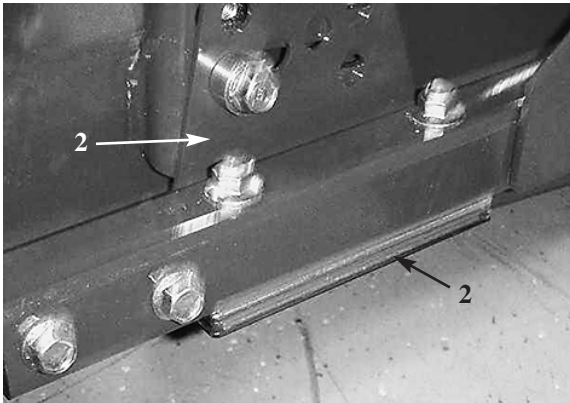

Figure 11

1. Height of cut bracket
2. Shims

3. Install height-of-cut bracket to deck frame with remaining shims assembled below the height-of-cut bracket.
4. Secure socket head bolt/spacer and flange nut.

NOTE: Socket head bolt/spacer are held together with Loctite to prevent the spacer from falling inside the deck frame.

5. Verify 12 o'clock height and re-adjust if needed.
6. Determine if only one or both height-of-cut brackets need to be adjusted. If the 3 or 9 o'clock side is $0.38 \pm 0.76\text{cm}$ higher than the new front height, then no adjustment is needed for that side. Adjust the other side to within $\pm \pm 0.76\text{cm}$ of the correct side.
7. Adjust the right and/or left height-of-cut brackets by repeating steps 1 through 3.
8. Secure carriage bolts and flange nuts.
9. Again, verify 12, 3, and 9 o'clock heights.

Removing the Cutter Blade (Fig. 12)

The blade must be replaced if a solid object is hit, the blade is out of balance or if the blade is bent. Always use genuine TORO replacement blades to be sure of safety and optimum performance. Never use replacement blades made by other manufacturers because they could be dangerous.

1. Raise the cutting deck to the highest position, shut off the engine and engage the parking brake. Block the cutting deck to prevent it from falling accidentally.
2. Grasp the end of the blade using a cloth or thickly padded glove. Remove the blade bolt, cup, and blade from the spindle shaft.

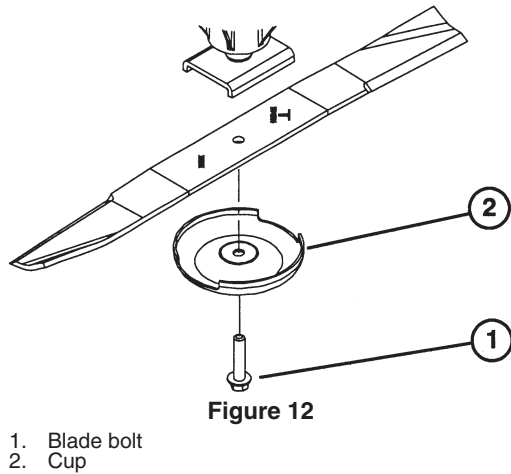

Figure 12

3. Install the blade sail facing toward the cutting deck with the cup and blade bolt. Tighten the blade bolt to (115-149 N•m).

Do not try to straighten a blade that is bent, and never weld a broken or cracked blade. Always use a new blade to assure continued safety certification of the product.

Inspecting And Sharpening The Blade (Fig. 13–14)

1. Raise the cutting deck to the highest position, shut the engine off and engage the parking brake. Block the cutting deck to prevent it from falling accidentally.
2. Examine the cutting ends of the blade carefully, especially where the flat and curved parts of the blade meet (Fig. 13-A). Since sand and abrasive material can wear away the metal that connects the flat and curved parts of the blade, check the blade before using the machine. If you notice wear (Fig. 13-B), replace the blade; refer to Removing The Cutter Blade.

If the blade is allowed to wear, a slot will form between the sail and flat part of the blade (Fig. 13-C). Eventually a piece of the blade may break off and be thrown from under the housing, possibly resulting in serious injury to yourself or a bystander.

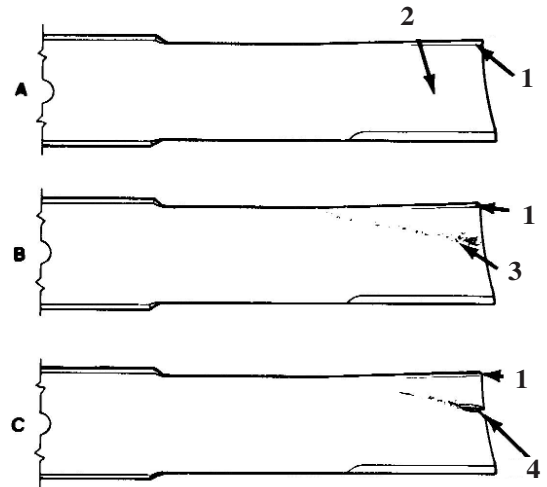

Figure 13

1. Sail
2. Flat part of blade
3. Wear
4. Slot formed

3. Inspect the cutting edges of all blades. Sharpen the cutting edges if they are dull or nicked. Sharpen only the top of the cutting edge and maintain the original cutting angle to make sure of sharpness (Fig. 27). The blade will remain balanced if the same amount of metal is removed from both cutting edges.

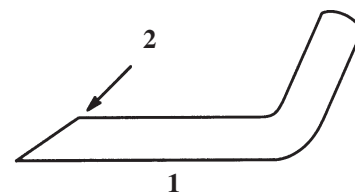

Figure 14

1. End view
2. Sharpen at this angle only

4. To check the blade for being straight and parallel, lay the blade on a level surface and check its ends. Ends of the blade must be slightly lower than the center, and the cutting edge must be lower than the heel of the blade. This blade will produce good quality of cut and require minimal power from the engine. By contrast, if a blade that is higher at the ends than the center, or if the cutting edge is higher than the heel, the blade is bent or warped and must be replaced.
5. Install the blade-sail facing toward the cutting deck with the cup, lockwasher and blade bolt.

Tighten the blade bolt to 115-149 N•m.

Blade Stopping Time

The blades of the cutting deck should come to a complete stop in approximately 5 seconds after the cutting deck engagement switch is shut down.

NOTE: Make sure the decks are lowered onto a clean section of turf or hard surface to avoid thrown dust and debris.

To verify this stopping time, have a second person stand back at least six meters from the deck and watch the blades on one of the cutting decks. Have the operator shut the cutting decks down and record the time it takes for the blades to come to a complete stop. If this time is greater than 7 seconds, the braking valve needs adjustment. Call your Toro Distributor for assistance in making this adjustment.

Servicing The Rear Roller (Fig. 15–17)

Disassembly

1. Loosen the locknut securing one end of the roller scraper rod to the mounting bracket. There should be approximately 0.13 –0.51mm end play in the loosened rod.
2. Remove the mounting screws securing the left and right scraper brackets to the roller mounts. Remove the scraper brackets.
3. Remove the mounting screws securing the roller mounts to the rear of deck frame. Remove the roller mounts.
4. Remove the set screws securing each end of the roller to the roller mounts.

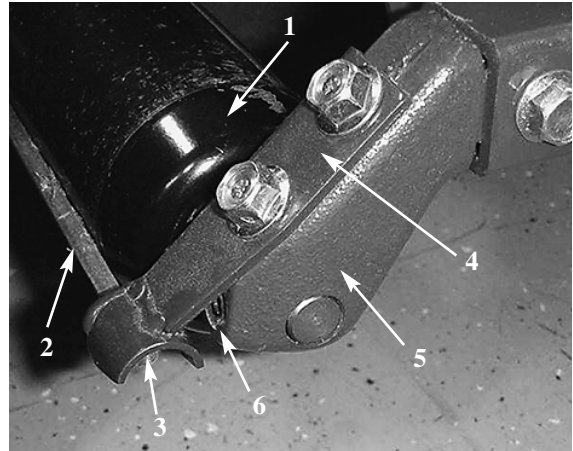

Figure 15

1. Rear roller
2. Scraper rod
3. Lock nut
4. Scraper mounting bracket
5. Roller mount
6. Setscrew

Seal Removal

Using a 6mm, 7.6 x7.6 cm square piece of steel and the following specifications, make a seal removal tool (Fig. 16).

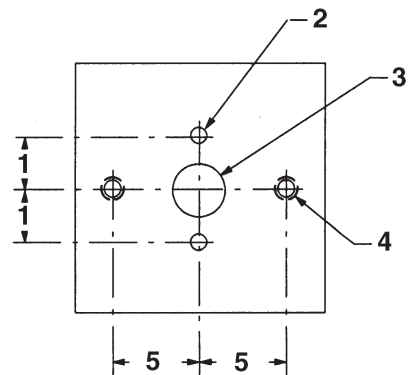

Figure 16

1. Slide the seal tool over the roller shaft.
2. Using the tool as a template, locate, mark and drill (2) 7/64" (.109") diameter holes in the outer face of the seal.
3. Screw (2) No. 8 (.164") diameter x .75" Self-tapping screws into the outer face of the seal.
4. Install (2) 1/4-20 x 1.00" capscrews into the seal tool.

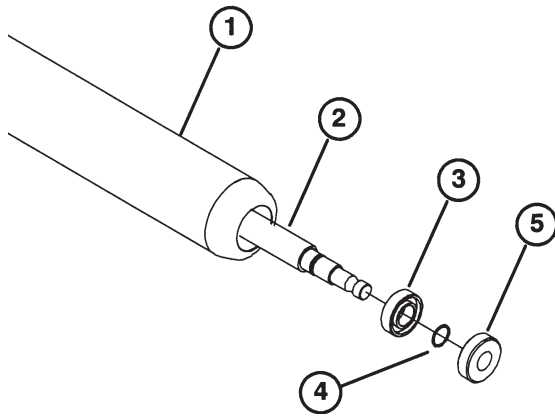

Figure 17

1. Roller
2. Roller shaft
3. Ball bearing
4. Retaining ring
5. Oil seal

4. Alternate the tightening sequence of the capscrews to pull the seal out of the housing.

Note: The seal will be destroyed when servicing the rear roller. Do not attempt to re-use these seals.

Bearing Removal

Reference: The bearings are pressed on to the shaft (0.0003" - .0016" interference) and loose fit to housing (0.0020" - .0035" clearance).

1. Remove the spiral retaining ring. Catch the removal notch with a pick and pull the ring off the shaft. Repeat on the other end.
2. Loosely secure the roller assembly in a bench vise and lightly tap one end of the roller shaft until it is free from the housing.
3. Remove the second bearing from the shaft. Support the bearing on the inner race and tap on the roller shaft.
4. Inspect the bearings, shaft, and spiral retaining ring for damage. Replace damaged components. Re-assemble the roller.

Assembly

1. Press the bearing onto one end of the shaft. Apply pressure to the inner race only.

2. Install the spiral retaining ring on same end as the assembled bearing.
3. Install the shaft with a single bearing into the tube assembly.
4. Install the second bearing into the roller assembly. Press only on the inner race. The inner race will contact the shoulder of the shaft before the outer race contacts the shoulder of the housing.
5. Install the second spiral retaining ring.
6. Press the new seal flush into the housing. Repeat for the other side.

Servicing The Front Roller (Fig. 18)

Disassembly

1. Remove the roller mounting bolt.
2. Insert the punch through the end of the roller housing and drive the opposite bearing out by alternating taps to the opposite side of the inner bearing race. There should be a 1/16" 1.52mm lip of the inner race exposed.

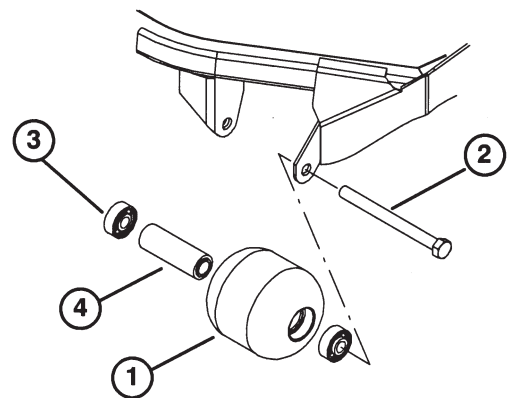

Figure 18

1. Front roller
2. Mounting bolt
3. Bearing
4. Bearing spacer

4. Push the second bearing out in the press.
5. Inspect the roller housing, bearings, and bearing spacer for damage. Replace damaged

components and re-assemble.

Assembly

1. Press the first bearing into the roller housing. Press on the outer race only or equally on the inner and outer race.
2. Insert the spacer.
3. Press the second bearing into the roller housing, pressing equally on the inner and outer race until the inner race comes in contact with the spacer.
4. Install the roller assembly into the deck frame.

Note: Securing the roller assembly with a gap larger than 1.52mm creates a side load on the bearing and can lead to premature bearing failure.

5. Verify that there is no more than a 1.52mm gap between the roller assembly and the roller mount brackets of the deck frame. If there is a gap over 1.52mm, install enough 1.6cm diameter washers to take up the slop.
6. Secure the mounting bolt to 108 N•m.

Cutting Deck Storage

If the cutting deck is separated from the traction unit for any length of time, install a spindle plug (part number 94-2703) in the top of the spindle to protect the spindle from dust and water.

Model and Serial Numbers

The cutting deck has two identification numbers: a model number and a serial number. The two numbers are stamped into a plate on the rear of the mower deck, under the cover. In any correspondence concerning the mower, supply the model and serial numbers to assure that correct information and replacement parts are obtained.

To order replacement parts from an authorized TORO Distributor, supply the following information:

1. Model and serial numbers of the machine.
2. Part number, description and quantity of parts desired.

Note: Do not order by reference number if a parts catalog is being used; use the part number.

