



MODEL 02003 - 90001 AND UP	OPERATOR'S MANUAL
GROUNDS PRO™ 2000-D	

To understand this product, and for safety and optimum performance, read this manual before starting operation. Pay special attention to **SAFETY INSTRUCTIONS** highlighted by this symbol.



FOREWORD

This operator's manual has instructions on safety, proper set-up and operation, adjustments and maintenance. Therefore, anyone involved with the product, including the operator, should read and understand this manual. This manual emphasizes safety, mechanical and general product information. **DANGER, WARNING** and **CAUTION** identify safety messages. Whenever the triangular safety alert symbol appears, understand the safety message that follows. For complete safety instructions, read pages 3–5. **IMPORTANT** highlights special mechanical information and **NOTE** emphasizes general product information worthy of special attention.

Whenever you have questions or need service, contact your local authorized Toro Distributor. In addition to having a complete line of accessories and professional turf care service technicians, the distributor has a complete line of genuine TORO replacement parts to keep your machine operating properly. Keep your TORO all TORO. Buy genuine TORO parts and accessories.

TABLE OF CONTENTS

SAFETY INSTRUCTIONS	3–5
SYMBOL GLOSSARY	6–8
SPECIFICATIONS	9–10
BEFORE OPERATING	11
CONTROLS	14
OPERATION	17
MAINTENANCE	22

Safety Instructions

Training

1. Read the instructions carefully. Be familiar with the controls and the proper use of the equipment.
 2. Never allow children or people unfamiliar with these instructions to use the lawn mower. Local regulations may restrict the age of the operator.
 3. Never mow while people, especially children, or pets are nearby.
 4. Keep in mind that the operator or user is responsible for accidents or hazards occurring to other people or their property.
 5. Do not carry passengers.
 6. All drivers should seek and obtain professional and practical instruction. Such instruction should emphasize:
 - the need for care and concentration when working with ride-on machines;
 - control of a ride-on machine sliding on a slope will not be regained by the application of the brake. The main reasons for loss of control are:
 - insufficient wheel grip;
 - being driven too fast;
 - inadequate braking;
 - the type of machine is unsuitable for its task;
 - lack of awareness of the effects of ground conditions, especially slopes;
 - ~~incorrect~~ hitching and load distribution.
3. **WARNING—Petrol is highly flammable.**
 - Store fuel in containers specifically designed for this purpose.
 - Refuel outdoors only and do not smoke while refueling.
 - Add fuel before starting the engine. Never remove the cap of the fuel tank or add petrol while the engine is running or when the engine is hot.
 - If petrol is spilled, do not attempt to start the engine but move the machine away from the area of spillage and avoid creating any source of ignition until petrol vapors have dissipated.
 - Replace all fuel tanks and container caps securely.
 4. Replace faulty silencers.

Operation

1. Do not operate the engine in a confined space where dangerous carbon monoxide fumes can collect.
2. Mow only in daylight or in good artificial light.
3. Before attempting to start the engine, disengage all blade attachment clutches and shift into neutral.
4. Do not use on slopes of more than:
 - Never mow side hills over 5°
 - Never mow uphill over 10°
 - Never mow downhill over 15°
5. Remember there is no such thing as a “safe” slope. Travel on grass slopes requires particular care. To guard against overturning:
 - do not stop or start suddenly when going up or downhill;
 - engage the clutch slowly, and always keep the machine in gear, especially when traveling downhill;
 - machine speeds should be kept low on slopes and during tight turns;

Preparation

1. While mowing, always wear substantial footwear and long trousers. Do not operate the equipment when barefoot or wearing open sandals.
2. Thoroughly inspect the area where the equipment is to be used and remove all objects which may be thrown by the machine.

- stay alert for bumps and hollows and other hidden hazards;
 - never mow across the face of the slope, unless the lawn mower is designed for this purpose.
6. Use care when pulling loads or using heavy equipment.
 - Use only approved drawbar hitch points.
 - Limit loads to those you can safely control.
 - Do not turn sharply. Use care when reversing.
 - Use counterweight(s) or wheel weights when suggested in the instruction handbook.
 7. Watch out for traffic when crossing or near roadways.
 8. Stop the blades rotating before crossing surfaces other than grass.
 9. When using any attachments, never direct discharge of material toward bystanders nor allow anyone near the machine while in operation .
 10. Never operate the lawn mower with defective guards, shields or without safety protective devices in place.
 11. Do not change the engine governor settings or overspeed the engine. Operating the engine at excessive speeds may increase the hazard of personal injury.
 12. Before leaving the operator's position:
 - disengage the power take-off and lower the attachments;
 - change into neutral and set the parking brake;
 - stop the engine and remove the key.
 13. Disengage the drive to attachments when transporting or not in use.
 14. Stop the engine and disengage the drive to the attachment
 - before refueling;
 - before removing the grass catcher;
 - before making height adjustments unless the

adjustment can be made from the operator's position.

- before clearing blockages;
 - before checking, cleaning or working on the lawn mower;
 - after striking a foreign object. Inspect the lawn mower for damage and make repairs before restarting and operating the equipment.
15. Reduce the throttle setting during engine runout and, if the engine is provided with a shutoff valve, turn the fuel off at the conclusion of mowing.

Maintenance and Storage

1. Keep all nuts, bolts and screws tight to be sure the equipment is in safe working condition.
2. Never store the equipment with petrol in the tank inside a building where fumes may reach an open flame or spark.
3. Allow the engine to cool before storing in any enclosure.
4. To reduce the fire hazard, keep the engine, silencer, battery compartment and petrol storage area free of grass, leaves, or excessive grease.
5. Check the grass catcher frequently for wear or deterioration.
6. Replace worn or damaged parts for safety.
7. If the fuel tank has to be drained, this should be done outdoors.
8. Be careful during adjustment of the machine to prevent entrapment of the fingers between moving blades and fixed parts of the machine.
9. On multi-bladed machines, take care as rotating one blade can cause other blades to rotate.
10. When the machine is to be parked, stored or left unattended, lower the cutting means unless a positive mechanical lock is used.

Sound & Vibration Levels

Sound Levels









This unit has a continuous A-weighted sound pressure level of 83 dB(A), based on measurements of identical machines per Directive 91/386/EEC and amendments.







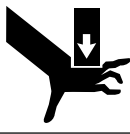

Vibration Levels





This unit has a vibration level of 2.5 m/s² at the hands, based on measurements of identical machines per ISO 5349 procedures.





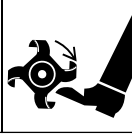

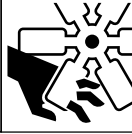
This unit does not exceed a vibration level of 0.5 m/s² at the posterior, based on measurements of identical machines per ISO 2631 procedures.



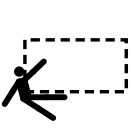

Symbol Glossary



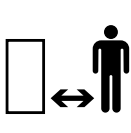
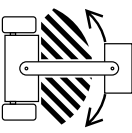
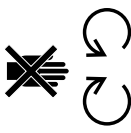

							
Caustic liquids, chemical burns to fingers or hand	Poisonous fumes or toxic gases, asphyxiation	Electrical shock, electrocution	High pressure fluid, injection into body	High pressure spray, erosion of flesh	High pressure spray, erosion of flesh	Crushing of fingers or hand, force applied from above	Crushing of toes or foot, force applied from above

							
Crushing of whole body, applied from above	Crushing of torso, force applied from side	Crushing of fingers or hand, force applied from side	Crushing of leg, force applied from side	Crushing of whole body	Crushing of head, torso and arms	Cutting of fingers or hand	Cutting of foot

						
Cutting or entanglement of foot, rotating auger	Severing of foot, rotating knives	Severing of fingers or hand, impeller blade	Wait until all machine components have completely stopped before touching them	Severing of fingers or hand, engine fan	Whole body entanglement, implement input drive line	Fingers or hand entanglement, chain drive

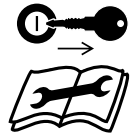
							
Hand & arm entanglement, belt drive	Thrown or flying objects, whole body exposure	Thrown or flying objects, face exposure	Runover/backover, (relevant machine to appear in dashed box)	Machine tipping, riding mower	Machine rollover, ROPS (relevant machine to appear or upward motion in dashed box)	Stored energy hazard, kickback	Hot surfaces, burns to fingers or hands

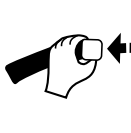
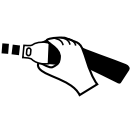
							
Explosion	Fire or open flame	Secure lifting cylinder with locking device before getting in hazardous area	Stay a safe distance from the machine	Stay clear of articulation area while engine is running	Do not open or remove safety shields while engine is running	Do not step on loading platform if PTO is connected to tractor & engine is running	Do not step

						
Shut off engine & remove key before performing maintenance or repair work	Riding on this machine is allowed only on a passenger seat & only if the driver's view is not hindered	Consult technical manual for proper service procedures	Fasten seat belts	Safety alert triangle	outline safety alert symbol	Read operator's manual

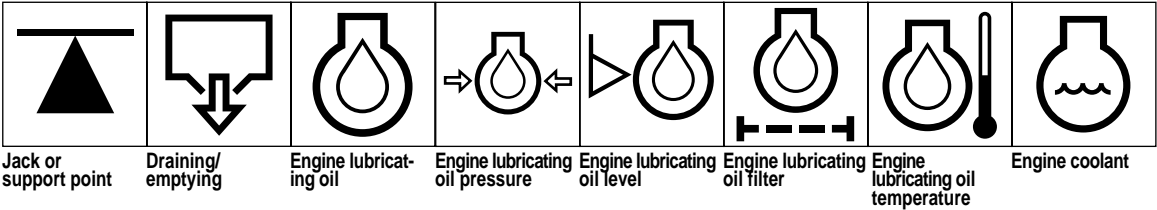
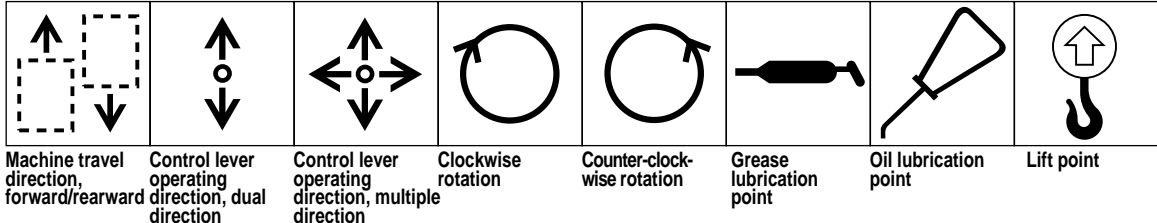
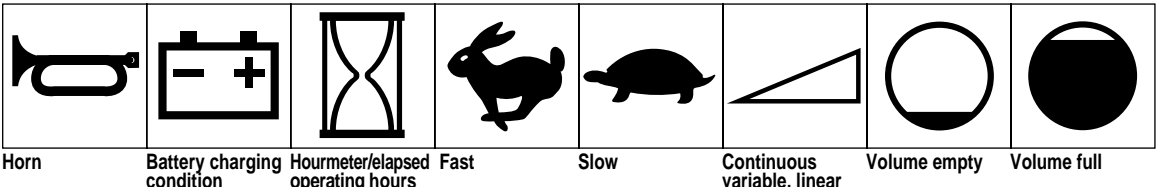
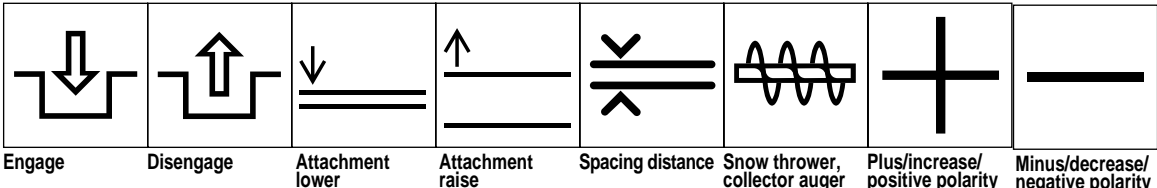
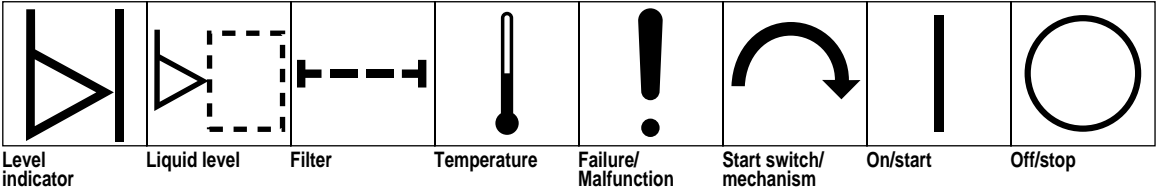
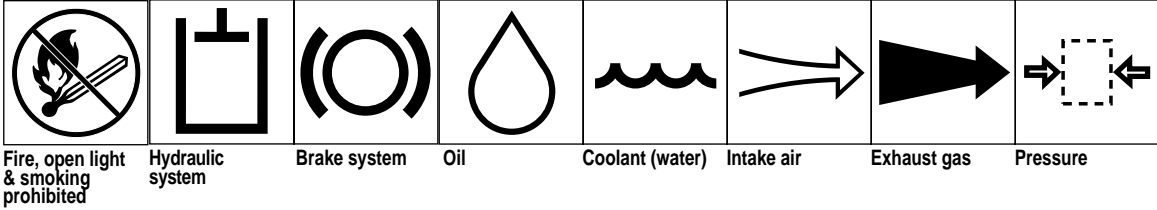
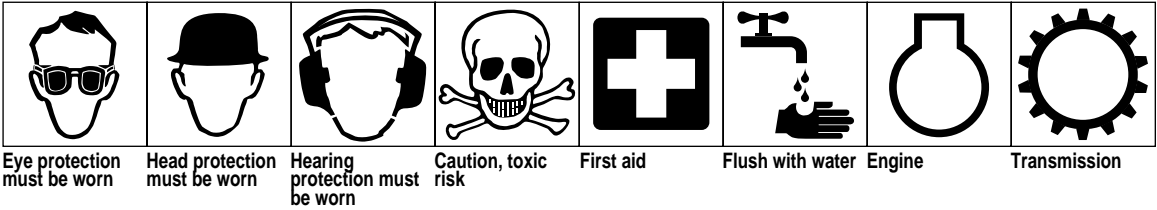

Symbol Glossary, continued

Engine coolant pressure	Engine coolant filter	Engine lubricating oil pressure	Engine intake/combustion air	Engine intake/combustion air pressure	Engine intake/air filter	Engine start	Engine stop

Engine failure/malfunction	Engine rotational speed/frequency	Choke	Primer (start aid)	Electrical preheat (low temperature start aid)	Transmission oil	Transmission oil pressure	Transmission oil temperature

Transmission failure/malfunction	Clutch	Neutral	High	Low	Forward	Reverse	Park

First gear	Second gear	Third gear (other #'s may be used until the maximum # of forward gears is reached.)	Hydraulic oil	Hydraulic oil pressure	Hydraulic oil level	Hydraulic oil filter	Hydraulic oil temperature

Hydraulic oil failure/malfunction	Parking brake	Fuel	Fuel level	Fuel filter	Fuel system failure/malfunction	Diesel fuel	Unleaded fuel

Headlights	Lock	Unlock	Differential lock	4-Wheel drive	Power Take-Off	Power Take-Off, rotational speed	Reel cutting element

Reel cutting element, height adjustment	Traction	Above working temperature range	Drilling	Manual metal arc welding	Manual	0356 Water pump	0626 Keep dry

0430 weight	Do not dispose in the garbage	CE logo

Specifications

Engine: Briggs & Stratton Daihatsu, diesel, three-cylinder, 4-cycle, overhead valve, water-cooled, 23 hp @ 3600 rpm, 850 cc displacement, governed speed of 3200 rpm. Mechanical fuel pump. 3.31 l oil capacity.

Cooling System: The cooling system is filled with a 50/50 solution of water and permanent ethylene glycol anti-freeze.

Fuel System: Fuel tank capacity 20 liters. Fuel filter with water separator. Fuel shut-off valve.

Traction Drive: Eaton model 11 hydrostatic transmission integrally coupled to a Peerless model 1310 axle. Travel speed range is 0–13.5Km/h (0–8.5 mph) forward and 4.8 Km/h reverse (0–3 mph).

Controls: Foot-operated traction pedal. hand-operated throttle, ignition switch, PTO switch, lift lever, parking brake and seat adjustment.

Cutting Drive: Constant-tension belt drive system with electric clutch utilizing a poly-V belt from the engine to the jackshaft and BX section V-belt drive from the jackshaft to each cutting unit.

Tires and Wheels: Two 23 x 8.5-12 front-drive turf tires with 4-ply construction. Rear tires for the four-wheel configuration, 16 x 6.5-6 turf tires with 4-ply construction. Rear tire for the three-wheel configuration, 18 x 6.5-8 with 4-ply construction.

Electrical Features: 12-volt, 255 cold cranking amps at 180 C, 50-amp reserve capacity at 270 C. Battery, 16-amp alternator, seat, traction, PTO and parking brake interlock switches; electrical leads provided for optional light and hour meter installations.

Steering: Pinion and gear sector with solid control link to the rear steer assembly, 2.5 turns lock to lock.

Brakes: Service braking accomplished through hydrostatic transmission. Parking brake controls secondary shaft internal to the axle assembly and is actuated by a control lever.

Main Frame: All-steel welded construction utilizing

tubular and formed sheet metal sections

Seat: Standard cushion seat and optional deluxe suspension seat with arm rest and weight adjustment. The seat is adjustable fore and aft. Arm rest kit also available.

Lift System: Category “0” A-Frame mounting system connected to the tractor via parallel linkage. One double-acting 60 mm bore, 140-mm stroke hydraulic cylinder receiving oil from hydrostatic transmission charge pump via the control valve with float position. Maximum operating pressure is 6895 kPa. When the traction unit is equipped with cutting units, all three units are raised and lowered via the single control lever. The lift system works with the electric clutch to engage and disengage the cutting units.

Overall Dimensions and Weight:

Wheel Tread Width	105.3 cm
Width across Front Tires	132 cm
Wheel Base	138.5 cm
Overall Length w/ Cutting Units Installed	229 cm
Overall Height	119 cm
Tractor Weight	50.4 kg
Weight with 5-Blade Fixed Cutting Units	640 kg
Weight with 8-Blade Floating Cutting Units	696 kg
Overall Width w/Fixed-Head Units	195 cm
Overall Width w/Floating Head Units	203 cm
Transport Width w/Fixed Head Units	140 cm
Transport Width w/Floating Head Units	200 cm

Optional Equipment:

Left. 5-Blade Fixed Cutting Unit (2 req.)	Model No. 03434
Right. 5-Blade Fixed Cutting Unit	Model No. 03436
Left 8-Blade Floating Cutting Unit (2 req.)	Model No. 03437
Right 8-Blade Floating Cutting Unit	Model No. 03439
Lift Arm Kit, Fixed Cutting Unit	Model No. 02100
Lift Arm Kit, Floating Cuffing Unit	Model No. 02101
Rear Axle, 4 Wheel	Model No. 02201
Full Roller Kit*	Model No. 03440
Sectional Roller Kit*	Model No. 03445
Wiehle Roller Kit*	Model No. 03450
Skid Kit*	Model No. 03446
Anti-Scalp Roller Kit*	Model No. 03447
Grass Basket Kit, Floating C.U.	Model No. 02302
Grass Basket Kit, Fixed C.U.	Model No. 02304

Specifications

Remote Hydraulics Kit	Model No. 02300
Power Take-off Kit, 1:1 Ratio	Model No. 02301
Power Take-off Kit, 1.5:1 Ratio	Model No. 02303
Standard Seat Kit	Model No. 30769
Deluxe Suspension Seat Kit	Model No. 02305
Arm Rest Kit for Model 30769	Model No. 30707
Debris Blower	Model No. 02202
Large Pulley Kit	Part No. 98-5413
Roller Scraper Kit*	Part No. 60-9560
Comb Kit*	Part No. 67-9400
Rear Weight	Part No. 24-5790
Rear Weight (2)	Part No. 24-5780
Gauge Bar Kit	Part No. 13-8199
Backlap Kit	Part No. 84-5510
Tire Chains	Part No. 82531

*3 per kit

Before Operating

CHECK THE ENGINE OIL (Fig. 1)

The engine is shipped with 3.3 l of oil. However, check the oil level before and after you first start the engine.

1. Position the machine on a level surface.
2. Unscrew the dipstick and wipe it with a clean cloth. Screw the dipstick into the tube and make sure it is seated fully. Unscrew the dipstick and check the oil level. If it is low, remove the filler cap and add oil.
3. Use any high-quality detergent oil having the American Petroleum Institute—API—“service classification” SE, SF or SG. Recommended viscosity (weight) is SAE 30. Refer to the Engine Operator’s Manual for additional information.

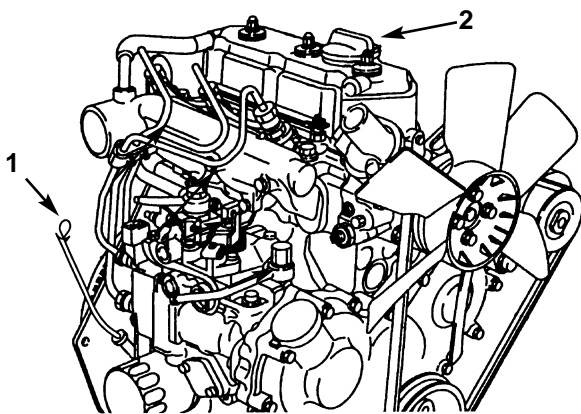

Figure 1

1. Dipstick
2. Filler cap

4. Pour the oil into opening in the valve cover until the oil level is up to the “FULL” mark on the dipstick. Add the oil slowly and check the level often during this process. **DO NOT OVERFILL.**

IMPORTANT Check the oil level every 8 operating hours or daily. Initially, change the oil after the first 8 hours of operation; thereafter, under normal conditions, change the oil every 50 hours and filter every 100 hours. However, change it more often when operating the engine in extremely dusty or dirty conditions.

5. Install the filler cap and the dipstick.

CHECK THE COOLING SYSTEM (Fig. 2)

Clean debris from the hood screens, engine and radiator daily—more often if conditions are extremely dusty and dirty; refer to the section on the Engine Cooling System.

The cooling system is filled with a 50/50 solution of water and permanent ethylene glycol anti-freeze.

Check level of coolant in expansion tank at beginning of each day before starting the engine.

! **CAUTION** !

If the engine has been running, pressurized hot coolant can escape when the radiator cap is removed and cause burns.

1. Check the level of coolant in the expansion tank. Coolant level should be between the marks on the side of the tank.



Figure 2

1. Expansion Tank

2. If coolant level is low, remove the expansion tank cap and replenish the system. **DO NOT OVERFILL.**
3. Install the expansion tank cap.

FILL FUEL TANK (Fig. 3)

Fuel tank capacity is 20 liters.

1. Remove the fuel tank cap.

2. Fill the tank to about one inch below the top of the *tank*, not the filler neck, with No. 2 diesel fuel. Then install the cap.



Figure 3

1. Fuel Tank Cap

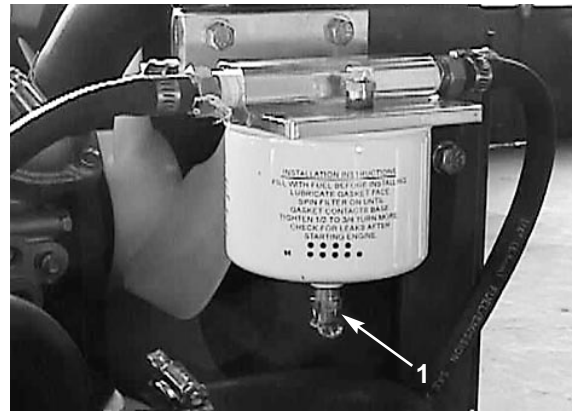

Figure 4

1. Drain valve

NOTE: Because the accumulated water will be mixed with diesel fuel, drain the fuel filter into a suitable Container and dispose of properly.

CHECK THE HYDRAULIC SYSTEM FLUID

The hydraulic system is designed to operate on SAE 10W-30 engine oil or, as a substitute, SAE 10W-40 engine oil. The reservoir is filled at the factory with 4.7 l of 10W-30 engine oil. Check the oil level before first starting the engine and daily thereafter.

1. Position the machine on a level surface and stop the engine.
2. Remove the access panel to expose the hydraulic system dipstick filler cap.

DRAINING WATER FROM FUEL FILTER/WATER SEPARATOR (Fig. 4)

Any water accumulation should be drained from the fuel filter/water separator before each use.

1. Position machine on a level surface and stop the engine.
2. Open the drain valve on the fuel filter/water separator and drain any accumulated water.



Figure 5

1. Access panel

3. Remove the dipstick cap from the filler neck and wipe it with a clean cloth. Insert the dipstick cap

onto the filler neck; then remove it and check the oil level.



Figure 6

1. Dipstick filler cap

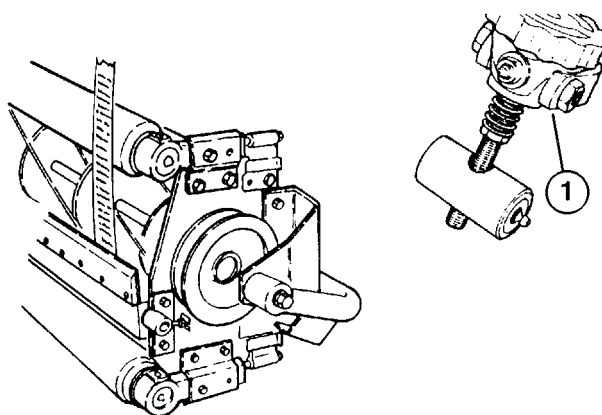

Figure 7

1. Bedknife adjusting knob

4. If the level is not within 3 cm from the FULL mark on the dipstick, add SAE 10W-30 engine oil to raise the level to the FULL mark. Do not overfill.
5. Install the dipstick filler cap onto the filler neck.
6. Run the engine for one minute, recheck the oil level and add more if needed.

CHECK TIRE PRESSURE

Correct air pressure in front and rear tires is 84–124 kPa.

LUBRICATE BEARINGS AND BUSHINGS

The traction unit and cutting unit's grease fittings must be lubricated with No. 2 General Purpose Lithium Base Grease.

CHECK REEL-TO-BEDKNIFE CONTACT

Each day before operating, check reel-to-bedknife contact.. There must be light contact across the full length of the reel and bedknife. Refer to *Adjusting the Bedknife Parallel to the Reel*.

Controls

Traction Pedal (Fig. 8)—The traction pedal: 1) makes the machine move forward, 2) moves it backward and 3) stops the machine. Using the heel and toe of your right foot, depress the top of the pedal to move forward and the bottom of the pedal to move backward or to assist in stopping when moving forward. Also, allow the pedal to move or move it to the neutral position to stop the machine. Do not rest the heel of your foot on reverse when going forward (Fig. 9).

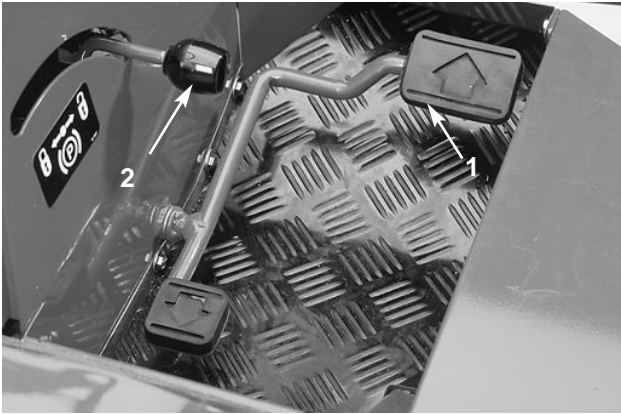

Figure 8

1. Traction pedal
2. Parking brake

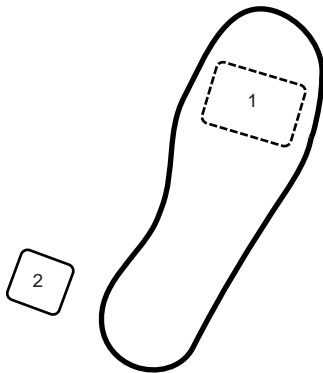

Figure 9

1. Forward
2. Reverse

Parking Brake (Fig. 8)—Whenever the engine is shut off, the parking brake must be engaged to prevent accidental movement of the machine. To engage the parking brake, pull back on the lever. After releasing the parking brake, move the mower slightly in reverse to release the brakes before moving forward.

Throttle (Fig. 10)—The throttle is used to operate the engine at various speeds. Moving the throttle upward

increases engine speed; downward decreases engine speed. The throttle also controls the speed of the reel blades and, with the traction pedal, controls the machine's ground speed.

Hour Meter (Fig. 10)—Shows total hours that the machine has been operated.

Lift Lever (Fig. 10)—The lift lever has four positions: LOWER, RAISE, NEUTRAL and FLOAT. To lower the cutting units to the ground, move the lift lever forward. To raise the cutting units, pull the lift lever rearward to the RAISE position.

PTO Switch (Fig. 10)—The switch has two positions: ENGAGE and DISENGAGE. Push the switch lever forward to engage the cutting units. Pull the switch level rearward to disengage the cutting units.

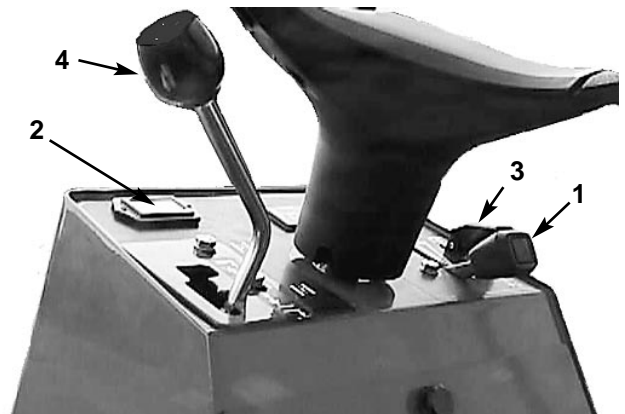

Figure 10

1. Throttle control
2. Choke control
3. PTO switch
4. Cutting unit lift lever

Ignition Switch (Fig. 11)—The ignition switch, used to start and stop the engine, has three positions: OFF, RUN (Glow Plug) and START. Turn the key clockwise—START position—to engage the starter motor. Release the key when the engine starts. The key will move automatically to the ON position. To shut the engine off, turn the key counterclockwise to the OFF position.

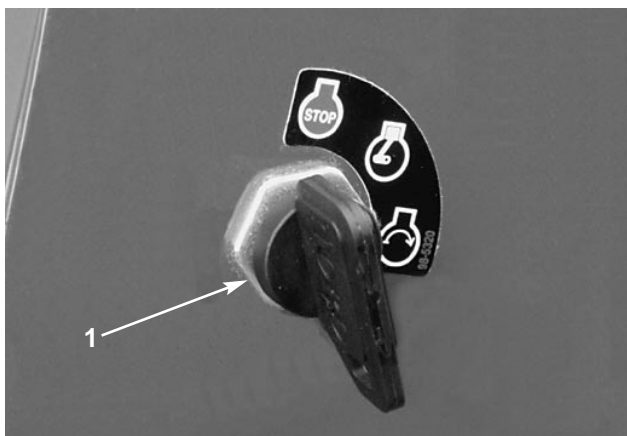

Figure 11

1. Ignition switch

Charge Indicator Light (Fig. 12)—Illuminates when the charging system malfunctions.

Oil Pressure Light (Fig. 12)—When the oil light is ON, it indicates the engine oil pressure is low. After the engine starts, the light should go out. When the engine is running, the light comes ON if the oil pressure drops below a safe operating level. If the light comes on while the engine is running, **stop the engine immediately and correct the cause of low oil pressure.**

Coolant Temperature Light (Fig. 12)—The coolant temperature light shows when the engine cooling system is overheated.

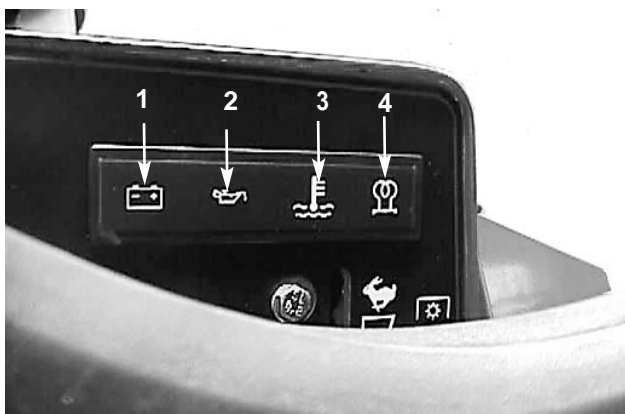

Figure 12

1. Charge indicator light
2. Oil pressure light
3. Coolant temperature light
4. Glow plug indicator light

Glow Plug Indicator Light (Fig. 12)—The glow plug indicator light comes on when the ignition switch is in the RUN position but should be out when the engine is running.

Seat Adjustments

Fore and Aft Adjustment—Move the lever on the side of the seat outward, slide the seat to the desired position and release the lever to lock the seat into position.

Deluxe Seat Adjustments (Fig. 13)

Fore and Aft Adjustment—Pull the handle on the left side of the seat assembly outward. Release the handle to lock the seat position.

Operator Weight Adjustment—Turn the knob clockwise to increase tension, counterclockwise to decrease tension.

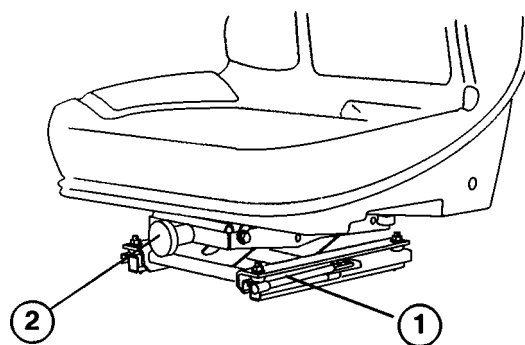

Figure 13

1. Fore and aft lever
2. Weight adjustment lever

Cutting Unit Lock-up Lever (Fig. 14)—Locks the rear cutting unit in the raised position.



Figure 14

1. Cutting unit lock-up lever
2. Seat adjusting screws

Fuel Valve (Fig. 15)—Close the fuel valve (located under the fuel tank) when storing the machine.



Figure 15

1. Fuel valve

Operation

STARTING/STOPPING THE ENGINE

1. Be sure the parking brake is set and the PTO switch is in the DISENGAGED position.
2. Remove your foot from the traction pedal and make sure the pedal is in the neutral position.
3. Move the throttle lever to the SLOW position.
4. Turn the ignition key clockwise to the RUN position. The glow plug indicator light will come on.
5. After the glow plug indicator light goes out, turn the key to the START position. When the engine starts, release the key.

IMPORTANT. Use starting cycles of no more than 30 seconds per minute to avoid overheating the starter motor.

6. If the engine does not start immediately, move the throttle control to FAST and turn the key to the START position.

NOTE: Additional starting cycles may be required when starting the engine for the first time after the fuel system has been completely without fuel.

7. Move the throttle to the SLOW position (if in FAST) and let the engine warm up for a few minutes before applying load.
8. When engine is started for the first time, or after overhauling the engine, operate the machine in forward and reverse for one to two minutes. Also operate the lift lever and PTO switch to be sure of proper operation of all parts.



CAUTION



Shut engine off and wait for all moving parts to stop before checking for oil leaks, loose parts and other malfunctions.

Turn the steering wheel to the left and right to check steering response. Then shut the engine off and check for oil leaks, loose parts and any other noticeable malfunctions.

9. To stop the engine, move the throttle control downward to the SLOW position, move the PTO switch to OFF and turn the ignition key to OFF. Remove the key from the switch to prevent accidental starting.
10. Set the parking brake.
11. Close the fuel shut off valve before storing the machine.

BLEEDING THE FUEL SYSTEM (Fig. 16)

1. Position the machine on a level surface. Make sure the fuel tank is at least half full.
2. Open the air bleed screw on the fuel injection pump.



DANGER



Because diesel fuel is flammable, use caution when storing or handling it. Do not smoke while filling the fuel tank. Do not fill the fuel tank while the engine is running, hot, or when the machine is in an enclosed area. Always fill the fuel tank outside and wipe up any spilled diesel fuel before starting the engine. Store fuel in a clean, safety-approved container and keep the cap in place. Use diesel fuel for the engine only; not for any other purpose.

3. Turn the ignition key to the ON position. The electric fuel pump will begin operation, thereby forcing air out around the bleed screw. Leave the key in the ON position until solid stream of fuel flows out around the screw. Tighten the screw and turn off the key.

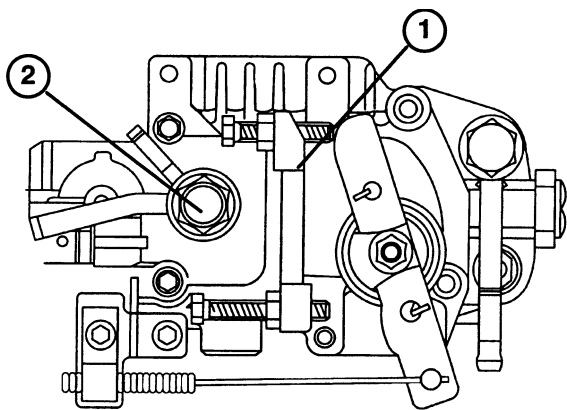

Figure 16

1. Fuel injection pump
2. Air bleed screw

OPERATING THE POWER TAKE OFF (PTO)

The power take off (PTO) switch engages and disengages power to the electric clutch.

Engaging the PTO

1. Release the parking brake.
2. Release pressure on the traction pedal to stop movement.
3. To engage, lift the cover and move the PTO switch forward to the “ON” position.

Disengaging the PTO

Closing the cover moves the PTO switch to the “OFF” (disengaged) position.

DRIVING FORWARD OR BACKWARD

Place the throttle control in the 3/4 position for best performance.

Forward

1. To go forward, place your foot on the traction pedal.
2. Release the parking brake.
3. Slowly press on the upper pad of the traction

control to move forward.

Backward

1. To go backward, place your foot on the traction pedal.
2. Release the parking brake.
3. Slowly press on the lower pad of the traction pedal to move rearward.

CHECK OPERATION OF INTERLOCK SWITCHES



CAUTION

Do not disconnect the safety switches because they are for the operator’s protection. Check switch operation daily to be sure the system is operating correctly. If a switch is not operating correctly, replace it before operating the machine. Replace the switches every two years to be sure of maximum safety.

1. With the operator off the seat, the traction pedal in neutral and the PTO switch in the disengage position, the engine should start. If either the traction pedal is depressed or the PTO switch is engaged, the engine should stop. Correct the problem if the system is not operating properly.
2. With the operator in the seat, the parking brake engaged and the engine running, depress the traction pedal either forward or reverse. The engine should stop. Correct the problem if the system is not operating properly.
3. With the operator in the seat, the parking brake engaged and engine running, lower the cutting units to the ground. Engage the PTO switch, the electric clutch on the engine should engage. Raise the cutting units, the PTO switch should disengage. Correct the problem if the system is not operating properly.

IMPLEMENT LIFT LEVER

Raising Attachments

Pull the implement lift lever rearward to raise an attachment to the desired height.

Lowering Attachments

Push the implement lift lever forward to lower the attachment.

NOTE: Hold the lift lever in the down position 1–2 seconds after the cutting unit touches the ground to retract the lift cylinder completely, allowing the cutting unit suspension to achieve proper position and to float with changes in ground contour. Return the lever to the neutral position to mow.

Refer to the attachment operator's manual for proper lift system operation.

PUSHING OR TOWING THE MACHINE

In an emergency, the traction unit can be pushed or towed for a very short distance. TORO does not recommend this as standard procedure.

IMPORTANT: Do not push or tow the traction unit faster than 3 to 5 kmh because the transmission may be damaged. If the traction unit must be moved a considerable distance, transport it on a truck or trailer.

1. To push or tow forward, the traction pedal must be fully depressed forward.
2. To push or tow in reverse, the traction pedal must be fully depressed in reverse.

TRAINING PERIOD

Before mowing with the Grounds Pro 2000-D, The TORO Company suggests you find a clear area and practice starting and stopping, raising and lowering the cutting units, turning, etc. This training period will be beneficial in gaining confidence in the performance of the Grounds Pro 2000-D.

BEFORE MOWING

Inspect the area for debris and clear the area. Determine the direction in which the area was last mowed. (Always mow in an alternate pattern from the previous mowing, so that the grass blades will be less apt to lay down and therefore be difficult to gather between the reel blades and bedknife.)

OPERATING CHARACTERISTICS

Practice operating the Grounds Pro 2000-D and become thoroughly familiar with it. Because of its hydrostatic transmission, its characteristics differ from many turf maintenance machines. Issues to consider when operating are the traction drive, engine speed and the load on the cutting units. Regulate the traction pedal to keep engine rpm high and somewhat constant while mowing to maintain adequate power for the traction and cutting units.

Follow operating guidelines presented in this manual and know how to operate the machine safely on all types of terrain. Use the slope gauge, page 34, to determine slope angles of questionable areas. Hills (or slopes) over 15 degrees should be traversed or mowed up and down, not side to side and hills over 20 degrees should generally be avoided unless special safeguards, skills and conditions exist.

Always plan well ahead to avoid the need for sudden stops, starts or turns. To stop, use the reverse pedal for braking. Before stopping the engine, disengage all controls, move the throttle to IDLE, and set the parking brake.

CAUTION: This product may exceed noise levels of 85 dB(A) at the operator position. Ear protectors are recommended for prolonged exposure to reduce the potential of permanent hearing damage.

TRANSPORT OPERATION

Be sure the lift arms are fully raised and the transport bracket is installed and secured with the retainer (Fig. 17). Also, lock the rear cutting unit in the raised position (Fig. 18).

While operating on slopes and uneven terrain, always reduce speed and use extreme caution before turning to reduce risk of tipping or losing control. Watch carefully and avoid holes in the terrain, sudden drop-offs and other hazards. To prevent costly damage and down time, familiarize yourself with the width of the Grounds Pro 2000-D. Do not attempt to pass between immovable objects placed close together.

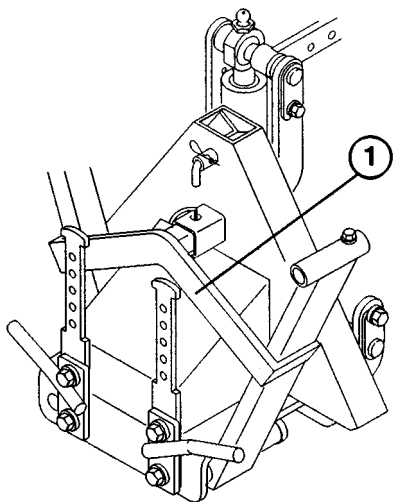

Figure 17

1. Transport bracket



Figure 18

1. Rear cutting unit lock-up lever

INSPECTION AND CLEAN-UP AFTER MOWING

After mowing, thoroughly wash the machine with a garden hose—without a nozzle—so excessive water pressure will not cause contamination and damage seals and bearings.

Note: Do not spray water directly onto a hot engine or hot bearings.

Make sure the cooling fins and the area around the engine air intake are kept free of dirt or grass clippings. After cleaning, inspect the machine for possible hydraulic fluid leaks, damage or wear to hydraulic and mechanical components. Check the cutting units for sharpness and correct reel-to-bedknife adjustment.

CUTTING UNIT CHARACTERISTICS

The single-knob bedknife adjustment system simplifies the procedure for delivering optimum mowing performance. The precise adjustment possible gives the control to provide a continual self-sharpening action—thus maintaining sharp cutting edges, good quality of cut, and greatly reduced need for routine backlapping.

Also, the rear roller positioning system permits optimum bedknife attitude and location for varying heights of cut and turf conditions.

DAILY CUTTING UNIT ADJUSTMENTS

Before each day's mowing, or as needed, check each cutting unit to verify correct bedknife-to-reel contact. Do this even though quality of cut is acceptable.

1. Shut off the engine and lower the cutting units onto a hard surface.
2. Slowly turn the reel in the reverse direction, listening for reel-to-bedknife contact. If no contact is evident, turn the bedknife adjusting knob clockwise, one click at a time, until you feel or hear light contact.
3. If you feel excessive contact, turn the bedknife adjusting knob counterclockwise, one click at a time, until no contact is evident. Then turn the knob one click at a time clockwise, until light contact is felt and heard.

IMPORTANT: Light contact is preferred at all times, otherwise bedknife and reel edges will not self-sharpen. If excessive contact is maintained,

bedknife and reel wear will accelerate. Uneven wear can result, adversely affecting quality of cut.

Note: As the reel blades run against the bedknife, a slight burr will appear on the front cutting edge surface over the full length of the bedknife.

Occasionally running a file across the front edge to remove this burr will improve cutting.

After extended running, a ridge will eventually develop at both ends of the bedknife. These must be rounded off or filed flush with the cutting edge of bedknife to assure smooth operation.

Maintenance

Maintenance Schedule

Maintenance Procedure		Maintenance Interval & Service				
Check battery fluid/connections	Every	Every	Every	Every	Every	Every
Lubricate grease fittings	25	50	100	200	400	800
Service the air cleaner	hours	hours	hours	hours	hours	hours
† Change the engine oil and filter † Check the cutting unit's belt tension						
Service the air filter cartridge † Change engine oil † Torque the wheel lug nuts Check the fan belt						
† Change the enging oil filter † Replace the hydraulic filter Adjust the clutch † Change the hydraulic fluid filter						
Change hydraulic fluid ‡Check engine RPM (idle and full throttle) Change front axle oil Replace the fuel filter cartridge						
De-carbon the combustion chamber Torque head bolts and adjust valves						
†Initial break in at 8 hours ‡Initial break in at 50 hours						
Replace moving hoses Replace safety switches Fuel tank—drain and flush Hydraulic tank—drain and flush		Recommendations Items are recommended every 1000 hours or 2 years, whichever occurs first.				

Daily Maintenance Checklist

- | | |
|---|--|
| ✓ Safety Interlock Operation | ✓ Hydraulic System Oil Level |
| ✓ Brake Operation | ✓ Hydraulic Hoses for Damage |
| ✓ Engine Oil & Fuel Level | ✓ Fluid Leaks |
| ✓ Cooling System Fluid Level ¹ | ✓ Tire Pressure |
| ✓ Air Cleaner | ✓ Instrument Operations |
| ✓ Drain Water/Fuel Separator | ✓ Reel-to-Bedknife Adjustment |
| ✓ Clean Engine and Radiator | ✓ Height-of-Cut Adjustment |
| ✓ Unusual Engine Noises | ✓ Cutting Unit Belt Adjustment |
| ✓ Unusual Operating Noises | Lubricate all grease fittings ¹ |
| | Touch up damaged paint |

¹= Immediately after every washing, regardless of the interval listed

LUBRICATION

GREASING BEARINGS AND BUSHINGS

The traction unit and cutting unit's grease fittings must be lubricated regularly with No. 2 General Purpose Lithium Base Grease. If the machine is operated under normal conditions, lubricate bearings and bushings after every 25 hours of operation. Bearings and bushings must be lubricated daily when operating conditions are extremely dusty and dirty. Dusty and dirty operating conditions could cause dirt to get into the bearings and bushings, resulting in accelerated wear. Lubricate grease fittings immediately after every washing, regardless of the interval listed.

The traction unit bearings and bushings, and the cutting unit lubrication points that must be lubricated are shown in the photos and illustrations.



Figure 19

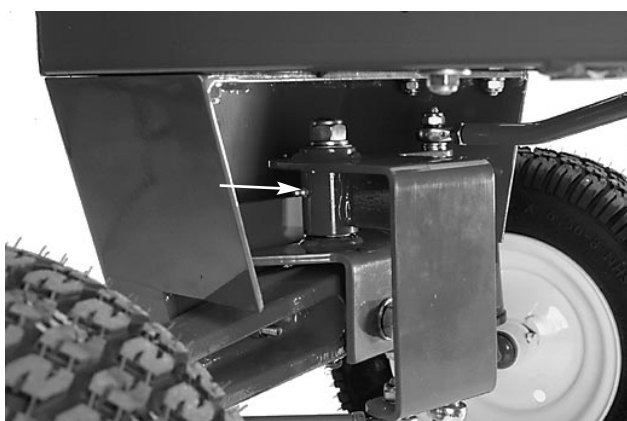

Figure 20



Figure 21



Figure 22

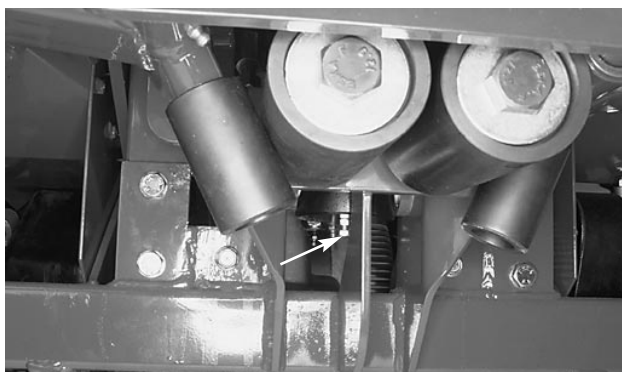

Figure 23

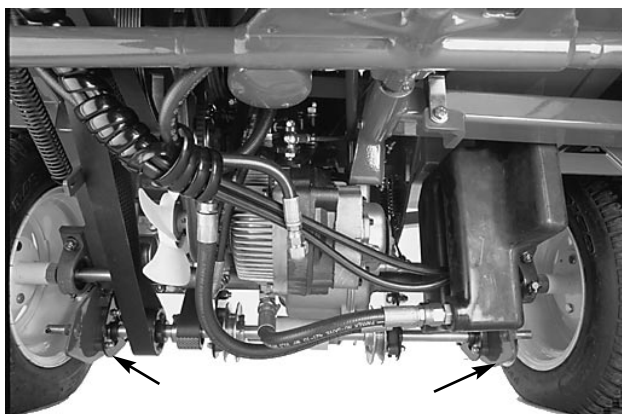

Figure 24

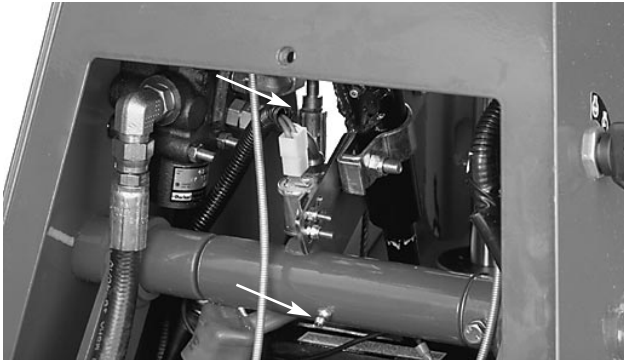

Figure 25



Figure 29

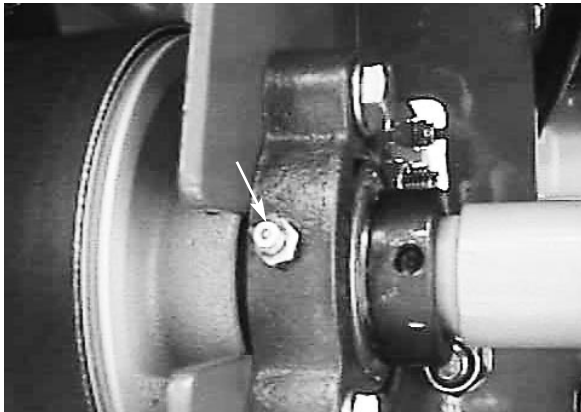

Figure 26

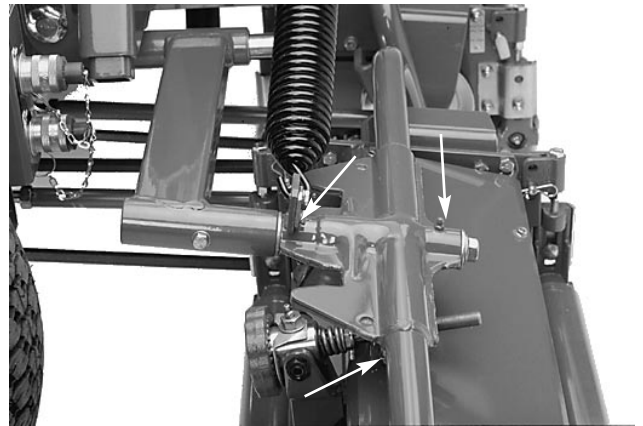

Figure 30



Figure 27

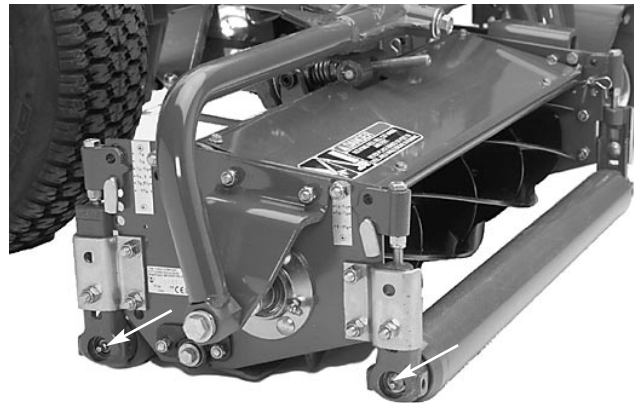

Figure 31



Figure 28

**CAUTION**

Before servicing or making adjustments to the machine, stop the engine and remove the key from the switch.

CHANGING THE ENGINE OIL AND FILTER (Fig. 32–33)

Change the oil and filter initially after the first 8 hours of operation; thereafter change the oil every 100 hours and filter every 200 hours.

Note: Change the oil and filter every 25 hours when operating under heavy load or high ambient temperatures.

1. Remove the drain plug and oil fill cap and let oil flow into drain pan. When the oil stops, install the drain plug.

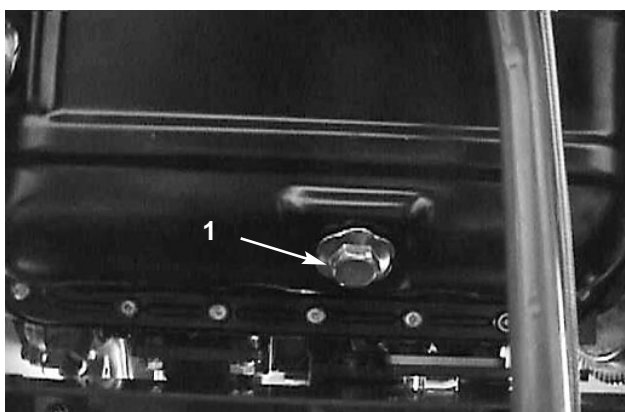
**Figure 32**

1. Drain plug

2. Remove the oil filter. Apply a light coat of clean oil to the new filter gasket.

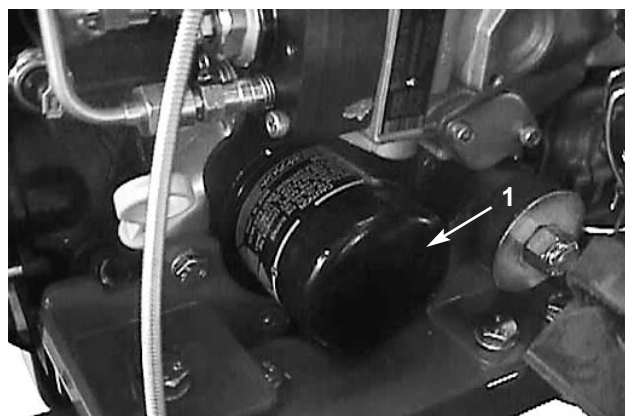
**Figure 33**

1. Oil filter

3. Screw the filter on by hand until the gasket contacts the filter adapter, then tighten $\frac{1}{2}$ to $\frac{3}{4}$ turn further. **DO NOT OVER-TIGHTEN.**
4. Add oil to the crankcase; refer to CHECK THE ENGINE OIL.
5. Start the engine and check for leaks around the filter.
6. Dispose of the oil properly.

SERVICING THE AIR CLEANER (Fig. 34)

Clean the air filter cartridge after every 25 operating hours. Service it more often (every few hours) if operating conditions are extremely dusty or sandy.

Replace the cartridge after every 100 operating hours, or yearly.

1. Unlock the clamps and remove the air cleaner cover.
2. Remove the cartridge from the air cleaner body.

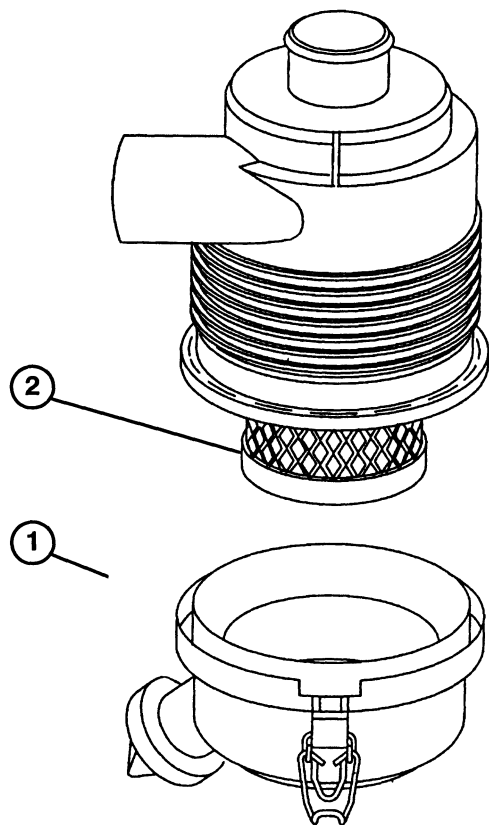

Figure 34

1. Air cleaner cover
2. Air cleaner cartridge

3. Clean the cartridge by tapping gently on its end with the handle of a screwdriver. Replace the cartridge if it is very dirty or damaged.
4. Install the cartridge in the body.
5. Install the cover and lock clamps.

FUEL SYSTEM

Fuel Tank

Drain and clean the fuel tank every 2 years. Also, drain and clean the tank if the fuel system becomes contaminated or if the machine is to be stored for an extended period. Use clean fuel to flush out the tank.

Fuel Lines and Connections

Check lines and connections every 400 hours or yearly, whichever comes first. Inspect for deterioration, damage, or loose connections.

Fuel Filter/Water Separator

Drain water or other contaminants from the fuel filter water separator (Fig. 35) daily.

1. Place a clean container under the fuel filter.
2. Loosen the drain plug on the bottom of the filter canister. Tighten the plug after draining.



Figure 35

1. Fuel filter

Replace the filter canister after every 400 hours of operation.

1. Clean the area where the filter canister mounts.
2. Remove the filter canister and clean the mounting surface.
3. Lubricate the gasket on the filter canister with clean oil.
4. Install the filter canister by hand until the gasket contacts the mounting surface, then turn it an additional 1/2 turn.

ADJUSTING THE THROTTLE CONTROL(Fig. 36)

Proper throttle operation depends proper adjustment. Before adjusting the carburetor, make sure the throttle control operates properly.

1. Move the remote throttle control lever to the SLOW position.
2. Loosen the cable clamp screw securing the cable to

the engine.

3. Move the cable until the speed control lever contacts the idle speed screw.

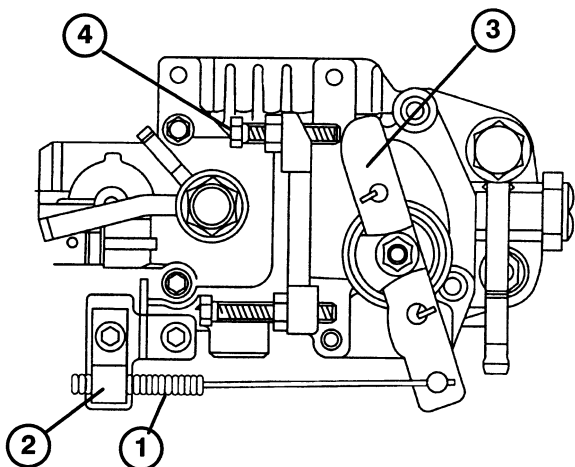

Figure 36

1. Throttle cable
2. Cable clamp
3. Speed control lever
4. Idle speed screw

4. Tighten the cable clamp screw and check the engine RPM setting.

ADJUSTING IDLE SPEED (Fig. 36)

1. Move the remote throttle control lever to the SLOW position.
2. Loosen the lock nut on the idle speed screw.
3. Adjust the idle speed screw to obtain 1100 rpm.
4. Tighten the lock nut.

CHECKING THE PARKING BRAKE

1. Park the machine on a level surface, disengage the PTO switch, set the parking brake and turn the ignition key to "OFF" to stop the engine. Remove the key.
2. The drive wheels must lock when the brake is applied. Adjustment is required if the wheels turn and do not lock; refer to *Adjusting the Brake*.
3. Release the brake; wheels should turn freely.

4. If both conditions are met, no adjustment is required.

IMPORTANT: With the parking brake released, the drive wheels must turn freely. If brake action and free wheel rotation cannot be achieved, contact your service dealer immediately.

ADJUSTING THE PARKING BRAKE (Fig. 37)

If drive wheels do not turn when the brake lever is in the OFF position, or the brake does not hold when the lever is in the ON position, an adjustment is required.

1. Move the brake lever to the ON position.
2. Measure the distance between the disc brake actuating arm and the stop pin on the axle bracket assembly. Distance should be less than 6 mm.
3. If the distance is greater than 6 mm, tighten the locknut to decrease distance.
4. With the brake lever OFF, check the clearance between the brake pads and the disc with a feeler gauge. Correct clearance is approximately 2.5 mm (.010 in.).
5. The actuating arm should be no more than 10 mm away from STOP with the brake lever in the OFF position.

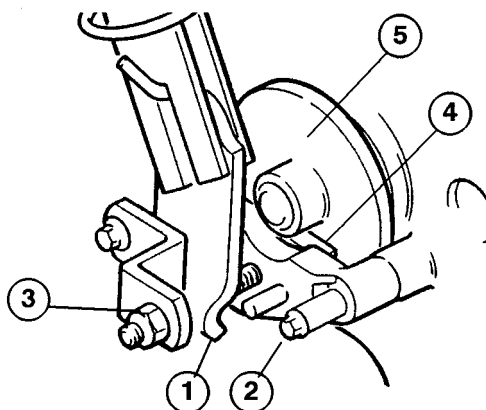

Figure 37

1. Brake actuating arm
2. Stop pin
3. Locknut
4. Disc pad
5. Disc

6. Check the brake operation again; refer to *Checking the Brake*.
7. Check adjustment. Drive wheels should turn freely when the brake lever is in the OFF position.

ADJUSTING TOE-IN & STEERING STOPS (Fig. 38)

(4-Wheel Axle Only)

1. Make sure both tie rods are adjusted to the same length.
2. Measure toe-in distance (at axle height) at front and rear of steering tires. Front measurement must be 2–4 mm less than the rear measurement.
3. Loosen the jam nuts and rotate the tie rod to adjust the front of the tires in or out.



Figure 38

1. Tie rod
2. Steering stop

4. Loosen the jam nuts and adjust the left and right steering stops to allow 6-mm clearance for steering arm in a full left and full right turn. Tighten jam nuts.

ADJUSTING THE TRANSMISSION FOR NEUTRAL (Fig. 39)

With the machine on a level surface and the parking brake disengaged, the machine must not creep when the traction pedal is released. If it does creep, an adjustment is required.

1. Park the machine on a level surface, lower the cutting unit and shut off the engine. Disengage the PTO switch and engage the parking brake.
2. Jack up the front of the machine until the tires are off the shop floor. Support the machine with jack stands to prevent it from falling accidentally.
3. Loosen the lock nut on the adjustment cam.

! **WARNING** !

The engine must be running so final adjustment of the traction adjustment cam can be performed. To guard against possible personal injury, keep hands, feet, face and other parts of the body away from the muff muffler other hot parts of the engine, and other rotating parts.

4. Start the engine and turn the adjusting cam in either direction until the wheels stop rotating.
5. Stop the engine and tighten the lock nut to secure adjustment.
6. Start the engine and check adjustment. Repeat adjustment if necessary.
7. Stop the engine. Remove the jack stands and lower the machine to the shop floor. Test drive the machine to be sure it does not creep.



Figure 39

1. Adjustment cam
2. Locknut

ADJUSTING THE ELECTRIC CLUTCH (Fig. 40)

The clutch is adjusted to ensure proper engagement and braking action.

1. Disengage the PTO switch, set the parking brake, and turn the ignition key to "OFF" to stop the engine. Remove the key.
2. Adjust the clutch by tightening or loosening the lock nuts on the flange studs.
3. Check adjustment by inserting a feeler gauge through the slots next to the studs.
4. The correct disengaged clearance between the clutch plates is 0.23-0.30 mm. It will be necessary to check this clearance at each of the three slots to ensure the plates are parallel to each other.

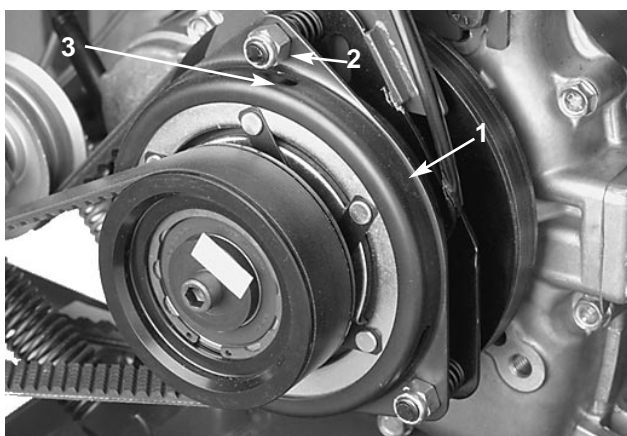

Figure 40

1. Clutch
2. Locknut
3. Adjustment slot

CHANGING HYDRAULIC SYSTEM OIL (Fig. 41–42)

The hydraulic system oil must be changed after every 400 hours of operation or yearly, whichever comes first. The reservoir has a capacity of 4.7 l.

1. Park the machine on a level surface, lower the cutting units, engage the parking brake, and shut off the engine.
2. Clean the area around the hydraulic oil filter and

remove the filter from the filter housing.

3. Disconnect the tube and hose assembly from the reservoir and allow the oil to flow into a drain pan.



Figure 41

1. Hydraulic filter

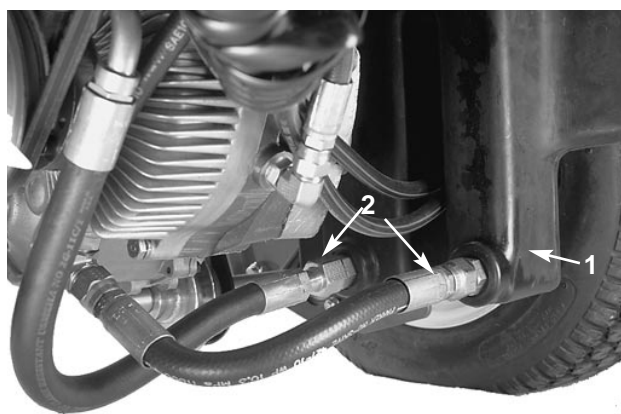

Figure 42

1. Reservoir
2. Hose assembly

Note: To drain the oil remaining in the system, disconnect the spark plug wires and crank the engine for 15 seconds. This will pump the remaining oil out of the system. Do not crank the engine for more than 15 seconds.

4. Install the new hydraulic filter to the filter housing.
5. Install the tube assembly and hose assembly to the reservoir.
6. Fill the reservoir to the proper level; refer to *Check Hydraulic System Fluid*.
7. Place all controls in the neutral or disengaged

position and start the engine. Run the engine at the lowest possible RPM to purge air from the system.

8. Run the engine until the lift cylinder extends and retracts and forward and reverse wheel motion is achieved.
9. Stop the engine and check the oil level; add oil if necessary.
10. Check all connections for leaks.

CHANGING THE HYDRAULIC OIL FILTER (Fig. 41)

The hydraulic oil filter must be serviced at regular intervals. The intervals are: initially, after the first 8 hours of operation, and thereafter every 200 hours of operation or yearly, whichever comes first. Use a genuine TORO oil filter for replacement.

1. Remove the hydraulic oil filter from the mounting head.
2. Apply a film of oil on the gasket. Install the filter by hand until the gasket contacts the mounting head; then tighten the filter an additional 3/4 turn.
3. Start the engine and check for oil leaks. Allow the engine to run for about two minutes to purge air from the system. Then shut off the engine.
4. Check the level of oil; refer to *Check the Hydraulic System Fluid*.

CHANGING FRONT AXLE OIL (Fig. 43)

After every 400 hours of operation, change the oil in the front axle.

1. Drive the machine for five minutes before changing oil to warm the axle oil. Warm oil flows more freely and carries more contaminants than cold oil.
2. Clean the area around the drain plug and place a drain pan below the drain plug on axle.

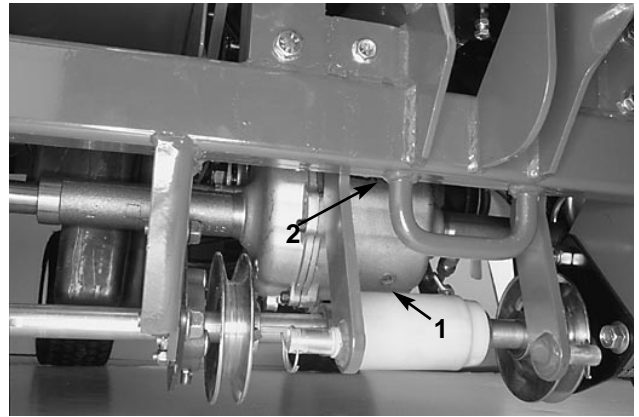

Figure 43

1. Drain plug
2. Fill plug

Remove the drain plug and allow the oil to flow into drain pan. After the oil is drained, reinstall drain plug.

Remove the fill plug and fill to plug level with ISO 150/220 (SAE EP-90) oil.

ADJUSTING THE CUTTING UNIT BELTS (Fig. 44)

Make sure cutting unit belts are properly tensioned to assure correct operation and prevent unnecessary wear. Check all belts often.

1. The cutting unit drive belts should have a maximum deflection of 12 mm with a 3.7 kg load applied.
2. Loosen the jam nut on the front end of the belt tension rod. Turn the rod to lengthen or shorten the rod to the desired length. Then tighten the jam nut.

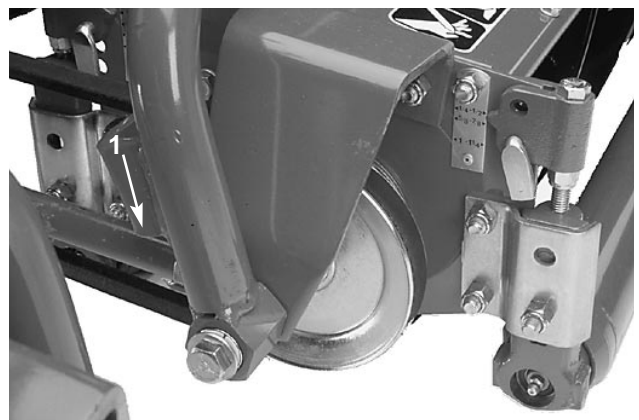



Figure 44

1. Belt tension rod

BATTERY CARE

1. Battery electrolyte level must be maintained and the top of the battery kept clean. If the Grounds Pro 2000-D is stored in a location where temperatures are extremely high, the battery will run down more rapidly than if it is stored in a cooler location.

	CAUTION	
<p>Since the gasses from the battery and the gasoline fumes are explosive, keep open flames and electrical sparks away from the area; do not smoke.</p>		

2. Check the electrolyte level every 25 operating hours or, if the machine is in storage, every 30 days.
3. Maintain cell level with distilled or demineralized water. Do not fill cells above the bottom of the split ring inside each cell.
4. Keep the top of the battery clean by washing it periodically with a brush dipped in ammonia or bicarbonate of soda solution. Flush the top surface with water after cleaning. **Do not remove the fill caps while cleaning.**
5. Battery cables must be tight on terminals to provide good electrical contact.
6. If corrosion occurs at terminals, disconnect the cables—negative (–) cable first—and scrape the clamps and terminals separately. Reconnect the cables—positive (+) cable first—and coat the terminals with petroleum jelly.

WIRE HARNESS SERVICE

Prevent corrosion of wiring terminals by applying Grafo 11 2X (Skin-over) grease, Toro Part No. 505-47, to the inside of all harness connectors whenever the harness is replaced.

Whenever working with the electrical system, always disconnect the battery cables, negative (–) cable first to prevent possible wiring damage from electrical shorts.

Before welding on the machine, disconnect ground cable from the battery to prevent damage to the electrical system.

FUSES (Fig. 45)

There are two fuses (50 amp and 10 amp) in the machine's electrical system. They are located under the hood against the back side of the seat panel.





Figure 45



1. Fuse block

BACKLAPPING THE CUTTING UNITS

The cutting units may be backlapped on the machine. Backlap Kit, Part no. 84-5510 is available from your Authorized TORO Distributor.

Backlap according to procedures in the Toro Sharpening Reel and Rotary Mowers Manual Form No. 80-300 PT.

	CAUTION	
<p>Be careful when lapping the reel because contact with the reel or other moving parts can result in personal injury.</p>		

	DANGER	
<p>Under no circumstances use a short-handled paintbrush. A Part #29-9100 handle assembly complete—or individual parts—are available from your local Authorized TORO Distributor.</p>		

IDENTIFICATION AND ORDERING

MODEL AND SERIAL NUMBER

The mower has two identification numbers: a model number and a serial number. The two numbers are stamped into a plate that is riveted to the frame. In any correspondence concerning the mower, supply the model and serial numbers to assure that correct information and replacement parts are obtained.

Note: Do not order by reference number if a parts catalog is being used; use the part number.

To order replacement parts from an Authorized TORO Service Dealer, supply the following information:

1. Model and serial numbers of the mower.
2. Part number, description and quantity of part(s) desired.

15° and 20° Slope Chart

