



# Multi Pro 5800 GeoLink® Precision Spray System Finishing Kit

Serial number 316000000 and After Multi Pro® 5800 Turf Sprayer

Model No. 41675—Serial No. 400000000 and Up

## Installation Instructions

# Introduction

The GeoLink® spray system kit is an attachment for a turf spray application vehicle and is intended to be used by professional, hired operators in commercial applications. It is designed primarily for spraying on well-maintained lawns in parks, golf courses, sports fields, and on commercial grounds.

Visit [www.Toro.com](http://www.Toro.com) for product safety and operation training materials, accessory information, help finding a dealer, or to register your product.

# Contents

Introduction .....	1	18 Connecting the Pressure-Sense Tube for the Dash Gauge .....	55
Safety .....	3	19 Installing the Navigation Receiver .....	56
Setup .....	4	20 Installing the Modem Antenna to the Machine .....	57
1 Preparing to Install the Kit .....	7	21 Installing the Monitor Visor .....	58
2 Disconnecting the Rear Wire Harness from the Optional Attachments .....	9	22 Installing the Sprayer Monitor .....	59
3 Removing the Pressure Control Switch—Optional Pivoting Hose-Reel Kit .....	10	23 Installing the Wire Harnesses for the Navigation Components .....	62
4 Removing the Undercarriage Shroud .....	11	24 Assembling the Modem Power Harness to the Machine .....	67
5 Removing the Engine-Control Module and Mounting Bracket (Machine Models with a Gasoline Engine) .....	12	25 Assembling the Modem Data Harness to the Machine .....	69
6 Disconnecting the Pressure-Sense Tube for the Dash Gauge .....	13	26 Installing the CL-55 Modem .....	71
7 Removing the Rear Wire Harness for the Machine .....	13	27 Routing the ISO-CAN Bus Harness .....	74
8 Removing the Rate-Control Switch .....	18	28 Removing the CAN Bus Resistor .....	76
9 Removing the Boom-Section Valves .....	18	29 Installing the Adapter Harness and Terminating Resistor .....	78
10 Installing the Flow Meter and Pressure Transducer .....	27	30 Connecting the Wire Harness for the Optional Pivoting Hose-Reel Kit .....	79
11 Installing the Valve Mount and Sprayer Valves .....	29	31 Connecting the Compressor Wire Harness for the Optional Foam-Marker Kit .....	79
12 Removing the Sprayer-Nozzle Hoses for the 3-Section System .....	32	32 Connecting the Optional Tank-Rinse Kit .....	80
13 Installing the Sprayer-Nozzle Hoses .....	34	33 Completing the Installation of the GeoLink Spray System-Finishing Kit .....	81
14 Assembling the Rear Wiring Harness to the Machine .....	41	34 Powering the GeoLink Components .....	83
15 Installing the Engine-Control Module and Mounting Bracket (Machine Models with a Gasoline Engine) .....	45	35 Verifying the Software Version .....	84
16 Installing the Undercarriage Shroud .....	46	36 Selecting the Units of Measure .....	85
17 Connecting the Rear Wire Harness .....	47	37 Creating a Field .....	85
		38 Creating a New Product and Application Rate .....	85
		39 Creating a Spray Job .....	85
		40 Checking the Spray System .....	86



41 Balancing the Agitation Bypass  
Valve ..... 88  
42 Performing a Flow Meter Calibration ..... 89  
43 Verifying the Cellular Status ..... 89  
44 Performing a Compass Calibration..... 90  
45 Clearing NVRAM ..... 90  
46 Performing a Compass Calibration..... 92

# Safety

## **⚠ WARNING**

Chemical substances used in the spray system may be hazardous and toxic to you, bystanders, animals, plants, soils, or other property.

- Carefully read and follow the chemical warning labels and material safety data sheets (MSDS) for all chemicals used and protect yourself according to the chemical manufacturer's recommendations. For example, use appropriate personal protective equipment (PPE), including face and eye protection, gloves, or other equipment to guard against personal contact with a chemical.
- There may be more than 1 chemical used and information on each chemical should be assessed.
- Refuse to operate or work on the sprayer if this information is not available.
- Before working on a spray system, ensure that the system has been triple rinsed and neutralized according to the recommendations of the chemical manufacturer(s) and that all the valves have been cycled 3 times.
- Verify that there is an adequate supply of clean water and soap nearby, and immediately wash off any chemicals that contact you.

# Installation

## Loose Parts

Use the chart below to verify that all parts have been shipped.

Procedure	Description	Qty.	Use
<b>1</b>	No parts required	–	Prepare to install the kit.
<b>2</b>	No parts required	–	Disconnect the rear wire harness from the optional attachment.
<b>3</b>	Switch plug (pivoting hose-reel kit—Toro Part No. 99-7420)	1	Disconnect the optional pivoting hose-reel kit.
<b>4</b>	No parts required	–	Remove the undercarriage shroud.
<b>5</b>	No parts required	–	Remove the engine-control module and mounting bracket (machine models with gasoline engines).
<b>6</b>	No parts required	–	Disconnecting the pressure-sense tube for the dash gauge.
<b>7</b>	Rear wire harness	1	Remove the rear wire harness for the machine.
<b>8</b>	Cable tie Switch plug	1 1	Remove the rate-control switch.
<b>9</b>	Fitting cap Cap (quick coupler) Retainer	1 3 3	Remove the boom-section valves.
<b>10</b>	Flow meter (for 2016 machines without the ExcelaRate sprayer system only)—not included in this kit; order Toro Part No. 106-1038. Flange clamp 51 mm (2 inches) Gasket (1-5/16 inch outside diameter) Barbed-flange fitting (1 inch) Hose (1 x 7-1/4 inches) Hose clamp Pressure transducer (for 2016 machines without the ExcelaRate sprayer system only)—not included in this kit; order Toro Part No. 130-8202. Fitting cap—ported (for 2016 machines without the ExcelaRate sprayer system only)—not included in this kit; order Toro Part No. 127-1185. Manifold Hose (1 x 8-1/2 inches) R-clamp	1 1 1 1 3 1 1 1 1 1 1	Install the flow meter and pressure transducer.

Procedure	Description	Qty.	Use
<b>11</b>	Valve mount and sprayer-valve assembly	1	Install the valve mount and valves.
	Bolt (4 x 10 mm)	4	
	Sprayer controller—GeoLink precision spray system kit (Model 41633 or Model 41634)	1	
	Flange locknut (4 mm)	4	
	Flange-head bolts (5/16 x 3/4 inch)	8	
	Flange locknuts (5/16 inch)	8	
	Hose clamp	1	
	Flange head bolt (1/4 x 3/4 inch)	2	
	Flange locknut (1/4 inch)	2	
<b>12</b>	No parts required	–	Remove the sprayer nozzle hoses.
<b>13</b>	Supply hose 279 cm (110 inches)	2	Install the sprayer nozzle hoses.
	Supply hose 234 cm (92 inches)	2	
	Supply hose 188 cm (74 inches)	4	
	Supply hose 81 cm (32 inches)	2	
	R-clamp	2	
	Double R-clamp	2	
	Single R-clamp	2	
<b>14</b>	Rear wire harness	1	Assemble the rear wiring harness to the machine.
	Cable tie	3	
<b>15</b>	No parts required	–	Install the engine-control module and mounting bracket (machine models with gasoline engines).
<b>16</b>	No parts required	–	Install the undercarriage shroud.
<b>17</b>	Cable tie	3	Connect the rear wire harness.
<b>18</b>	No parts required	–	Connect the pressure-sense tube for the dash gauge.
<b>19</b>	Receiver mount	1	Install the navigation receiver.
	U-bolt	2	
	Flange locknut (3/8 inch)	4	
	Modem antenna bracket	1	
	Hex-head bolt (5 x 16 mm)	3	
	Washer (5 mm)	3	
	Navigation receiver—GeoLink precision spray system kit (Model 41633 or Model 41634)	1	
<b>20</b>	Modem antenna—GeoLink precision spray system kit (Model 41633 or Model 41634)	1	Install the modem antenna to the machine.
	Cable ties—GeoLink precision spray system kit (Model 41633 or Model 41634)	7	

Procedure	Description	Qty.	Use
<b>21</b>	X25 Sprayer Monitor—GeoLink precision spray system kit (Model 41633 or Model 41634)	1	Install the monitor visor.
	Adhesive strips	2	
	Threaded standoff	1	
	Display hood	1	
<b>22</b>	Ball mount—GeoLink precision spray system kit (Model 41633 or Model 41634)	1	Install the sprayer monitor.
	Monitor arm—GeoLink precision spray system kit (Model 41633 or Model 41634)	1	
	Stiffener bracket	1	
	Flange-head bolt (1/4 x 1-1/2 inches)	4	
	Washer (1/4 inch)	4	
	Flange locknut (1/4 inch)	4	
<b>23</b>	Data and electrical harness—GeoLink precision spray system kit (Model 41633 or Model 41634)	1	Install the wire harnesses for the navigation components.
	Cable tie—GeoLink precision spray system kit (Model 41633 or Model 41634)	8	
<b>24</b>	Modem power harness—1850 mm (72-7/8 inches)—GeoLink precision spray system kit (Model 41633 or Model 41634)	1	Install the modem power harness.
	Cable ties—GeoLink precision spray system kit (Model 41633 or Model 41634)	5	
<b>25</b>	Modem data harness—300 cm (118 inches)—GeoLink precision spray system kit (Model 41633 or Model 41634)	1	Route the modem data harness.
	Cable ties—GeoLink precision spray system kit (Model 41633 or Model 41634)	8	
<b>26</b>	CL-55 modem—GeoLink precision spray system kit (Model 41633 or Model 41634)	1	Install the CL-55 modem.
	Modem bracket	1	
	Capscrew (#10-24 x 1-1/2 inches)		
	Spacer (1/4 x 3/4 inch)	2	
<b>27</b>	ISO-CAN bus harness—302 cm (119 inches)—GeoLink precision spray system kit Model 41633 or Model 41634)	1	Route the ISO-CAN bus harness.
	Cable ties—GeoLink precision spray system kit (Model 41633 or Model 41634)	12	
<b>28</b>	No parts required	–	Remove the CAN bus resistor.
<b>29</b>	Adapter harness—13 cm (5 inches)	1	Install the adapter harness and terminating resistor.
	Cable tie	1	

Procedure	Description	Qty.	Use
<b>30</b>	No parts required	–	Connect the wire harness for the optional pivoting hose-reel kit.
<b>31</b>	No parts required	–	Connect the optional foam-marker kit.
<b>32</b>	No parts required	–	Connect the optional tank-rinse kit.
<b>33</b>	No parts required	–	Complete the installation of the GeoLink spray system-finishing kit.
<b>34</b>	No parts required	–	Power the GeoLink components.
<b>35</b>	No parts required	–	Verify the software version.
<b>36</b>	No parts required	–	Select the units of measure.
<b>37</b>	No parts required	–	Create a field.
<b>38</b>	No parts required	–	Create a new product and application rate.
<b>39</b>	No parts required	–	Create a generic spray job.
<b>40</b>	No parts required	–	Check the spray system.
<b>41</b>	No parts required	–	Balance the agitation bypass valve.
<b>42</b>	No parts required	–	Perform a flow meter calibration.
<b>43</b>	No parts required	–	Verify the cellular status.
<b>44</b>	No parts required	–	Perform a compass calibration.
<b>45</b>	No parts required	–	Easing the nonvolatile RAM.
<b>46</b>	No parts required	–	Perform a compass calibration.

# 1

## Preparing to Install the Kit

No Parts Required

### Preparing the Sprayer Tank and Optional Rinse Tank

1. Park the machine on a level surface.
2. Engage the parking brake; refer to the *Operator's Manual*.
3. Extend the left and right boom sections to the horizontal position.
4. Shut off the engine; refer to the *Operator's Manual*.
5. Clean the sprayer; refer to Cleaning the Sprayer in the *Operator's Manual* for the machine.
6. **For machines with the optional tank-rinse kit, perform the following:**

**Important:** You must completely empty the sprayer tank before installing the GeoLink Spray System Finishing Kit.

- A. Pump the water from the rinse tank into the sprayer tank; refer to Operating the Rinse Kit in the *Installation Instructions* for the Tank-Rinse Kit.
  - B. Drain the water from the sprayer tank; refer to Cleaning the Sprayer in the *Operator's Manual* for the machine.
7. Remove the key from the key switch; refer to the *Operator's Manual*.

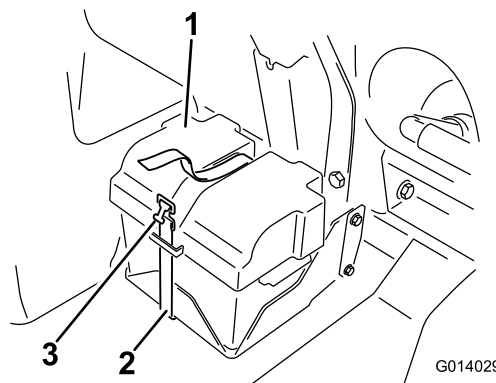

**Figure 1**

- |                  |           |
|------------------|-----------|
| 1. Battery cover | 3. Buckle |
| 2. Strap         |           |

## Disconnecting the Battery

1. Remove the battery cover and disconnect the negative (black—ground) cable from the battery post (Figure 1 and Figure 2).

### **⚠ WARNING**

Electrical sparks can cause the battery gasses to explode, resulting in personal injury.

Incorrect battery cable routing could damage the sprayer and cables, causing sparks.

- Always disconnect the negative (black) battery cable before disconnecting the positive (red) cable.
- Always connect the positive (red) battery cable before connecting the negative (black) cable.

Battery terminals or metal tools could short against metal sprayer components, causing sparks.

- When removing or installing the battery, do not allow the battery terminals to touch any metal parts of the sprayer.
- Do not allow metal tools to short between the battery terminals and metal parts of the sprayer.
- Always keep the battery strap in place to protect and secure the battery.

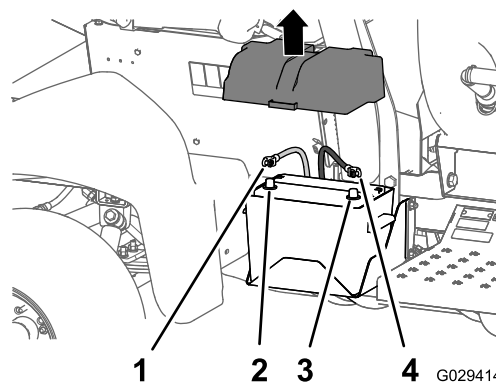

**Figure 2**

- |                           |                           |
|---------------------------|---------------------------|
| 1. Positive battery cable | 3. Negative battery post  |
| 2. Positive battery post  | 4. Negative battery cable |

2. Disconnect the positive (red) cable from the battery post (Figure 2).
3. Tilt both seats forward and secure them by moving the prop rods into the detents at the end of the slots at the center-console base.
4. Allow the engine to cool completely.

# 2

## Disconnecting the Rear Wire Harness from the Optional Attachments

No Parts Required

### Disconnecting the Pivoting Hose-Reel Kit

1. At the back of the machine, locate the wire harness for the electric-hose-reel kit at the back of the sprayer tank (A in [Figure 3](#)).

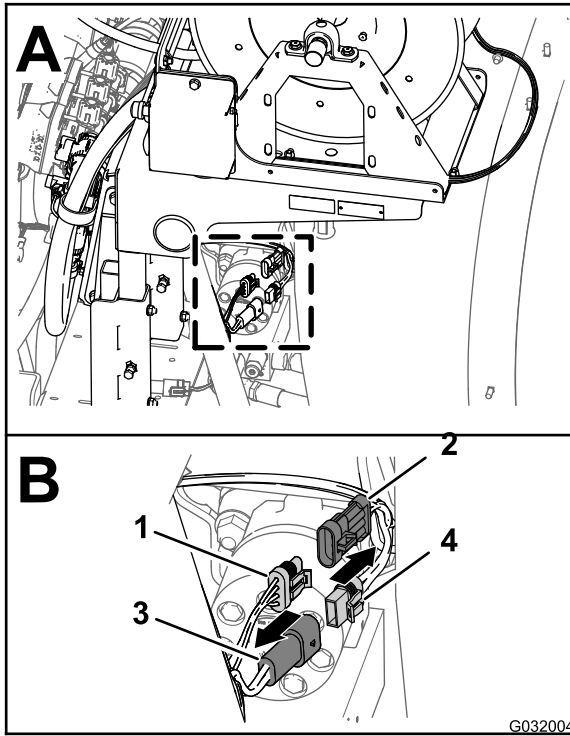

Figure 3

1. 3-socket connector (rear-main harness)
2. 3-pin connector (harness—electric-hose reel)
3. 2-pin connector (rear-main harness)
4. 2-pin connector (harness—electric-hose reel)

2. Disconnect the 2-socket connector of the harness for the electric-hose reel from the 2-pin connector of the rear-main harness (B in [Figure 3](#)).
3. Disconnect the 3-pin connector of the harness for the electric-hose reel from the 3-pin socket of the rear-main harness (B in [Figure 3](#)).

### Disconnecting the Compressor for the Foam-Marker Kit

1. At the back of the foam-marker tank, locate the wire harness at the compressor ([Figure 4](#)).

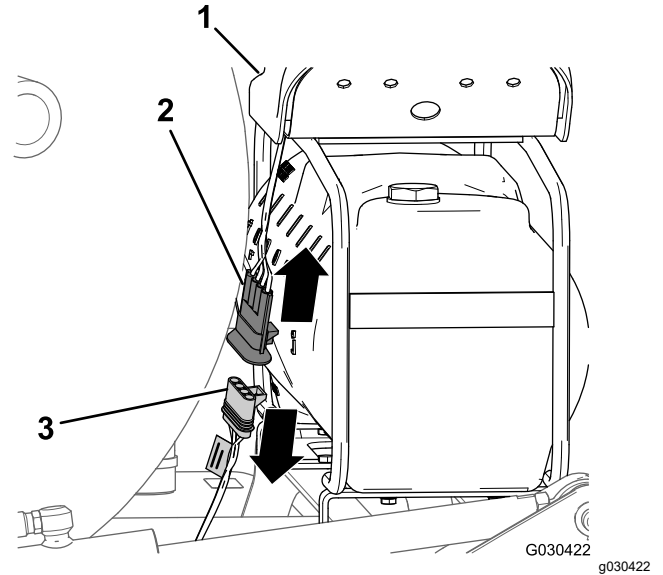
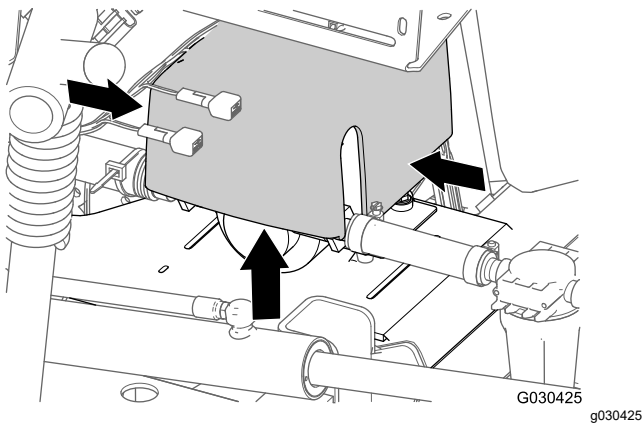

Figure 4

1. Compressor
  2. 4-pin connector (wire harness for the compressor)
  3. 4-socket connector (wire harness for the finishing kit)
2. Disconnect the 4-pin connector of the compressor harness from the 4-socket connector of the rear wire harness of the machine ([Figure 4](#)).

### Disconnecting the Pump for the Tank-Rinse Kit

1. At the back of the machine, press together the sides of the rinse-pump cover and lift the cover up until the tabs of the cover clear the slots in the saddle plate, and remove the cover from the machine ([Figure 5](#)).



**Figure 5**

2. Disconnect the 6-pin connector of the rinse-pump harness from the 6-socket connector of the rear, main harness (Figure 6).

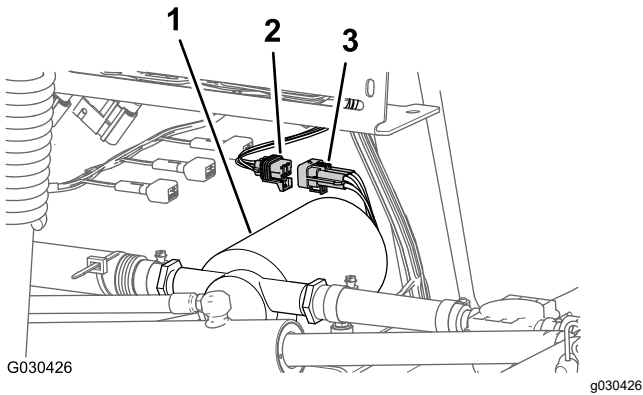

**Figure 6**

- |  |   |
|--|---|
| 1. Rinse pump                              | 3. 6-pin connector (rinse-pump harness) |
| 2. 6-socket connector (rear, main harness) |   |

# 3

## Removing the Pressure Control Switch—Optional Pivoting Hose-Reel Kit

Parts needed for this procedure:

1	Switch plug (pivoting hose-reel kit—Toro Part No. 99-7420)
---	--

### Procedure

1. Remove the 2 bolts (5/16 x 3/4 inch) and 2 locknuts (5/16 inch) that secure the control box to the reel-mounting plate (Figure 7).

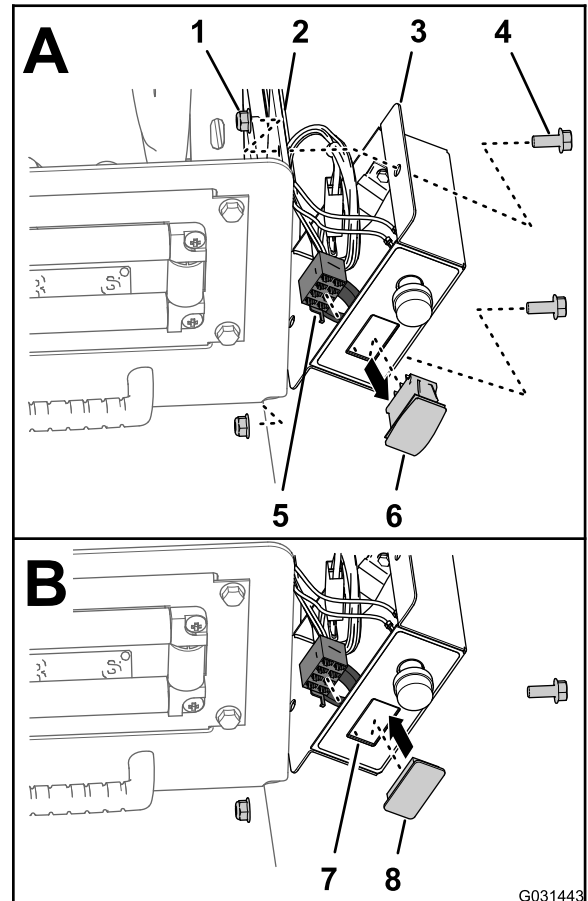

**Figure 7**

- |                           |   |
|---------------------------|---|
| 1. Locknut (5/16 inch)    | 5. 8-socket connector (control-box harness) |
| 2. Reel-mounting plate    | 6. Pressure-control switch                  |
| 3. Control box            | 7. Opening (control-box cover)              |
| 4. Bolt (5/16 x 3/4 inch) | 8. Switch plug                              |

2. Disconnect the 8-socket connector for the control box harness from the PRESSURE-CONTROL switch (Figure 7).
3. Route the 8-socket connector inside the control box (Figure 7).
4. Squeeze the lock tabs of the PRESSURE-CONTROL switch and press the switch out of the control box (Figure 7).

**Note:** You no longer need the switch that you removed from the machine.

5. Align the switch plug to the opening in the control box where you removed the switch (Figure 7).
6. Insert the switch plug into the control box until the plug snaps into the cover securely (Figure 7).
7. Align the control box to the reel-mounting plate (Figure 7) and secure the box to the plate with the 2 bolts (5/16 x 3/4 inch) and 2 locknuts (5/16 inch).
8. Torque the bolts and nuts to 1978 to 2542 N·cm (175 to 225 in-lb).

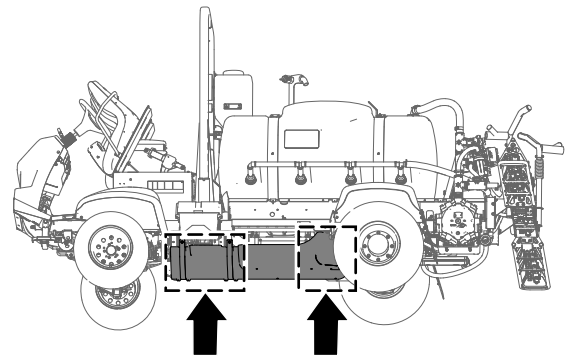

g189584

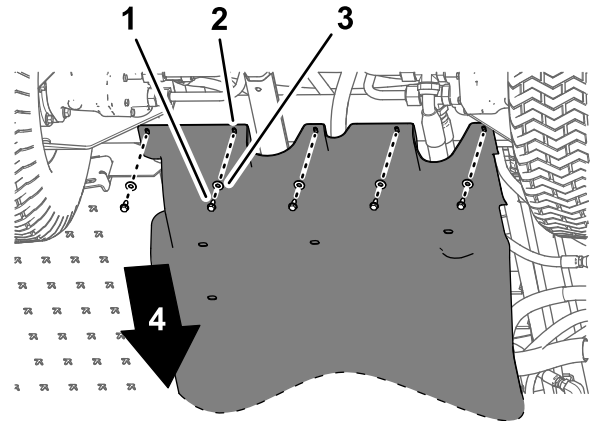

g189585

**Figure 8**

2017 machine shown; 2016 machines are similar

- |  |                         |
|--|-------------------------|
| 1. Flange-head bolts (5/16 x 7/8 inch) | 3. Washers (5/16 inch)  |
| 2. Undercarriage shroud                | 4. Front of the machine |

2. Remove the 4 flange locknuts (5/16 inch) from the bolts and carriage bolt that secure the support straps of the undercarriage shroud to the engine-mount brackets of the machine (Figure 9).

**Note:** Do not remove the bolts from the machine. Retain the flange locknuts for installation in step 3 of 16 [Installing the Undercarriage Shroud](#) (page 46).

# 4

## Removing the Undercarriage Shroud

**No Parts Required**

### Procedure

1. Remove the following hardware that secures the rear of the undercarriage shroud to the chassis of the machine (Figure 8):
  - **2016 machines**—7 flange-head bolts (5/16 x 7/8 inch) and 7 washers (5/16 inch)
  - **2017 and later machines**—5 flange-head bolts (5/16 x 7/8 inch) and 5 washers (5/16 inch)

**Note:** Retain the flange-head bolts and washers for installation in step 5 of 16 [Installing the Undercarriage Shroud](#) (page 46).

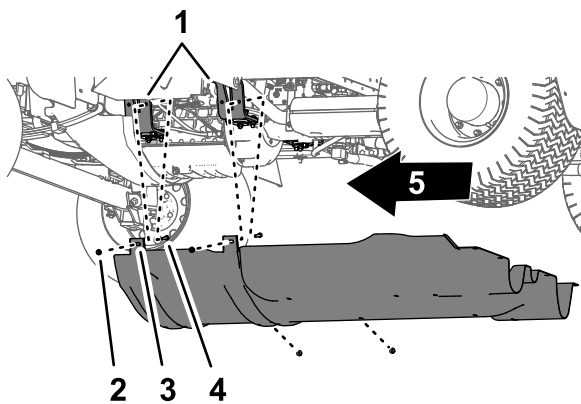

g189583

Figure 9

- |  |                                |
|--|--------------------------------|
| 1. Engine mounts                         | 4. Flange locknuts (5/16 inch) |
| 2. Bolt—shown for clarity; do not remove | 5. Front of the machine        |
| 3. Undercarriage shroud                  |                                |

- 
- Lift the support straps over the bolts that secure the undercarriage shroud to the engine-mount brackets.
  - Remove the undercarriage shroud from the machine (Figure 8 and Figure 9).

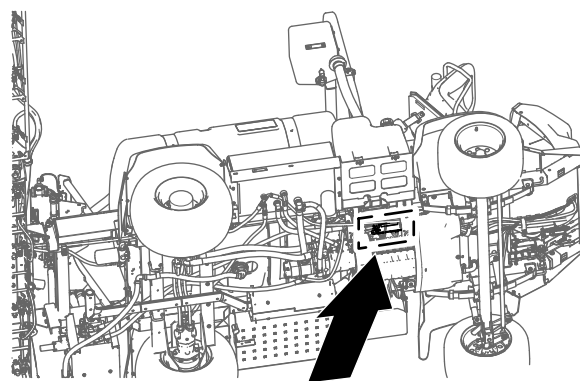

g189642

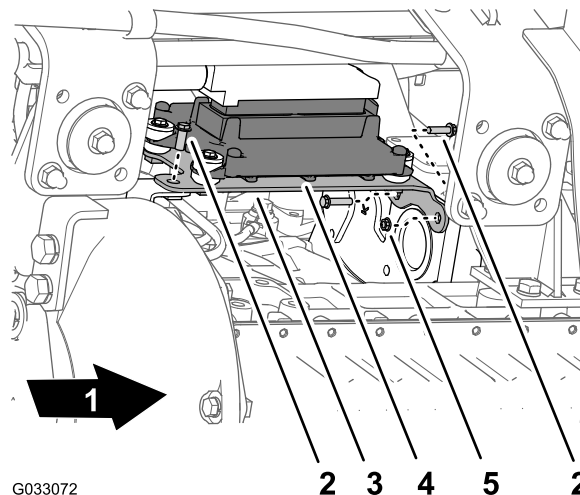

G033072

g033072

Figure 10

- |                         |                          |
|-------------------------|--------------------------|
| 1. Front of the machine | 4. Engine-control module |
| 2. Flange-head bolt     | 5. Flange nut            |
| 3. Mounting bracket     |                          |

- 
- Move the engine-control module and mounting bracket down and rearward to provide access to the connectors of the front and rear wiring harnesses for the machine.

**Note:** Do not remove or disconnect the engine-control module from the engine.

# 5

## Removing the Engine-Control Module and Mounting Bracket (Machine Models with a Gasoline Engine)

No Parts Required

### Procedure

- Remove the 3 flange head bolts and 1 flange nut that secure the mounting bracket for the engine-control module to the support bracket of the engine and accessory case of the engine (Figure 10).

**Note:** Retain the flange-head bolts and flange nut for installation in step 2 of [15 Installing the Engine-Control Module and Mounting Bracket \(Machine Models with a Gasoline Engine\)](#) (page 45).

# 6

## Disconnecting the Pressure-Sense Tube for the Dash Gauge

No Parts Required

### Disconnecting the Pressure-Sense Tube for the Dash Gauge—Machines Without an Optional Hose Reel Kit

**Note:** If your machine is equipped with an optional spray gun kit, refer to

1. Press in the collar for the tube coupler at the 90° elbow at the right boom-section valve ([Figure 11](#)).

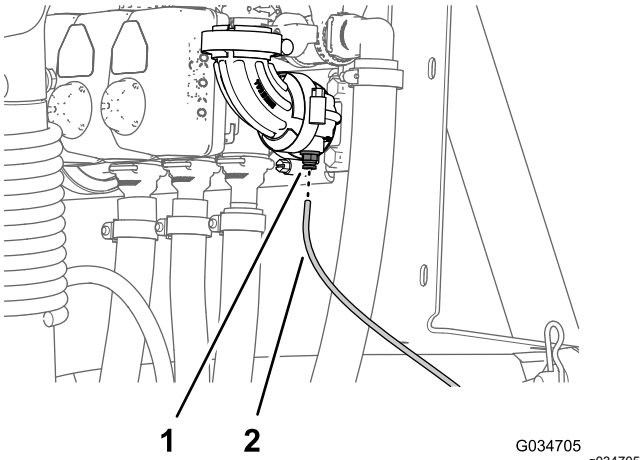

**Figure 11**

1. Tube coupler (90° elbow at the right boom-section valve)
2. Pressure-sense tube

2. Pull the pressure-sense tube for the dash pressure gauge out of the tube coupler ([Figure 11](#)).

### Disconnecting Pressure-Sense Tube and Supply Hose—Optional Spray Gun Kit or Optional Pivoting Hose Reel Kit

1. Press in the collar for the tube coupler in the 90° elbow of the right boom-section valve ([Figure 12](#) or [Figure 13](#)).

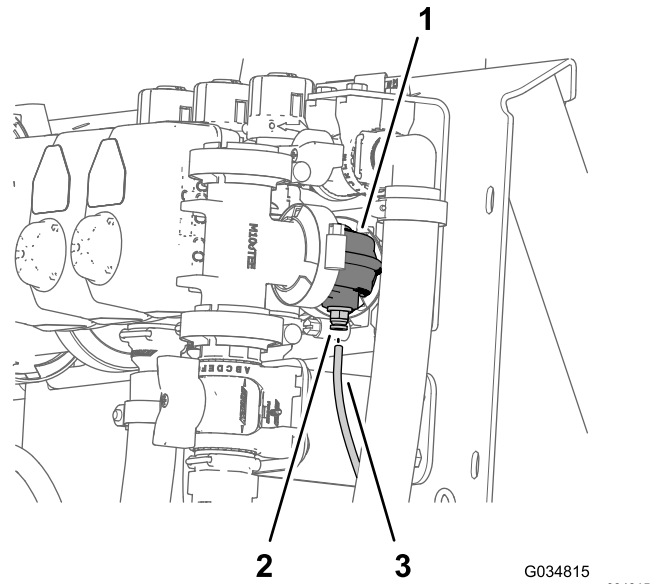

**Figure 12**

Optional Spray Gun Kit

1. 90° elbow (right boom-section valve)
2. Tube coupler
3. Pressure-sense tube (dash-pressure gauge)

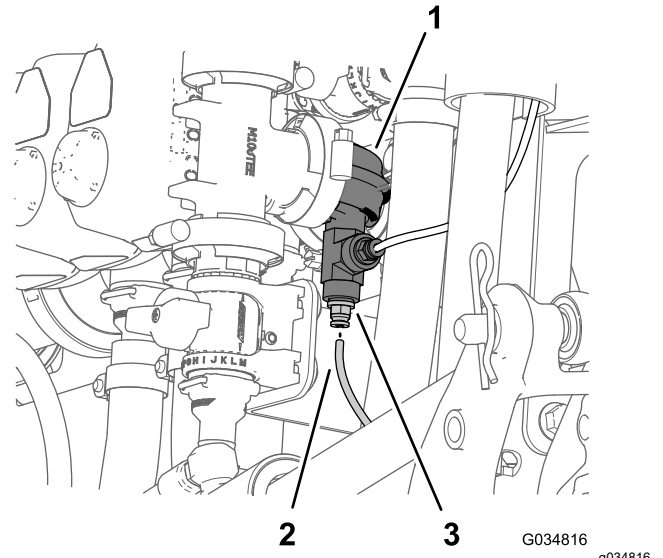

**Figure 13**

Optional Pivoting Hose-Reel Kit

1. 90° elbow (right boom-section valve)
2. Pressure-sense tube (dash-pressure gauge)
3. Tube coupler

2. Pull the pressure-sense tube for the dash pressure gauge out of the tube coupler ([Figure 12](#) or [Figure 13](#)).

**Note:** Do not remove the 90° elbow from the flange of the right boom-section valve.

# 7

## Removing the Rear Wire Harness for the Machine

Parts needed for this procedure:

1	Rear wire harness
---	-------------------

### Disconnecting the Front and Rear Wire Harnesses

**Note:** Use a machine hoist when disconnecting the front and rear wire harnesses.

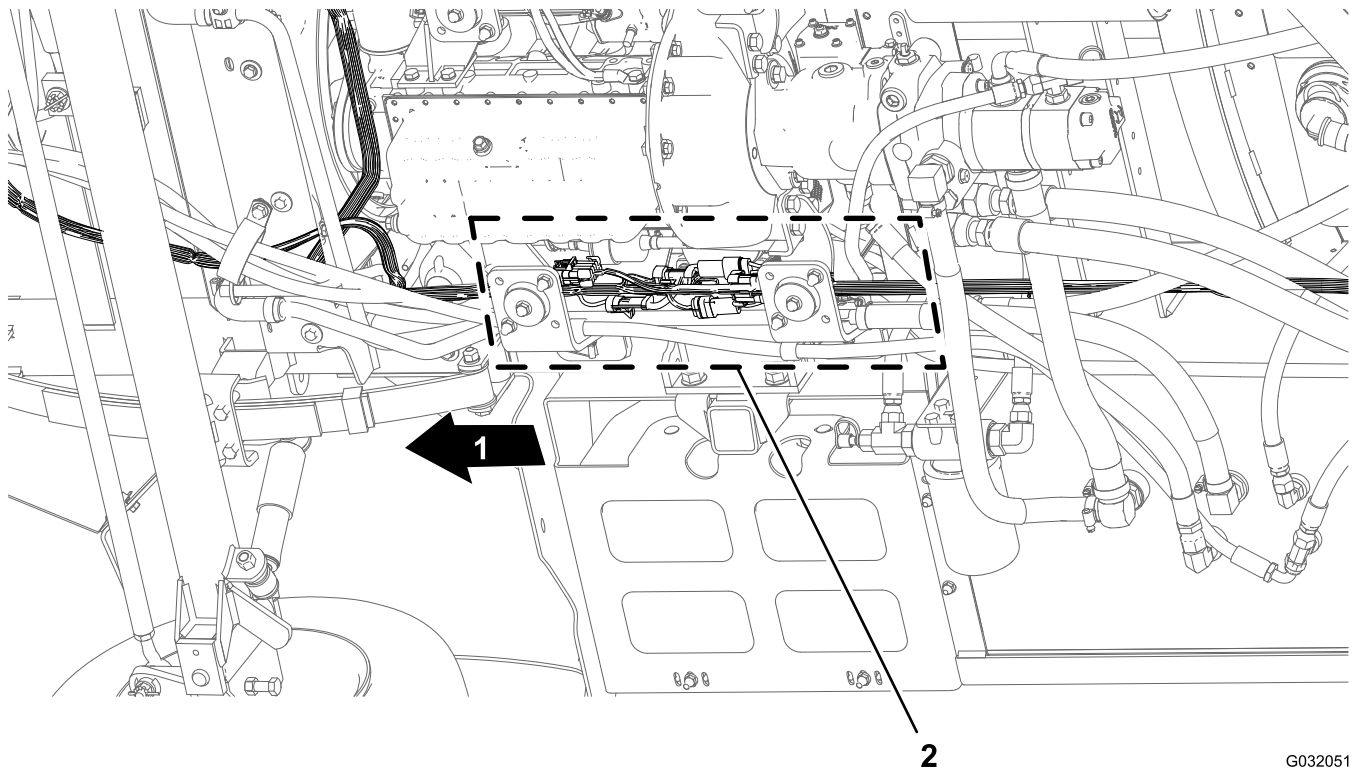
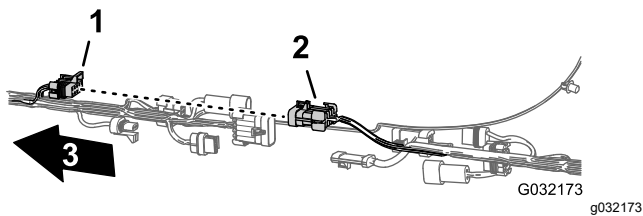

Figure 14

G032051  
g032051

1. Front of the machine
2. Connector interfaces (front and rear wire harnesses)

1. From under the machine along the right frame tube, locate the electrical connectors for the front and rear wire harnesses of the machine (Figure 14).
2. Disconnect the 6 pairs of connectors between the front and rear wire harnesses as shown in Figure 15 through Figure 20.



**Figure 15**

1. 10-pin connector—sprayer-harness interconnect (rear harness)
2. 10-socket connector—sprayer-harness interconnect (front harness)
3. Front of the machine

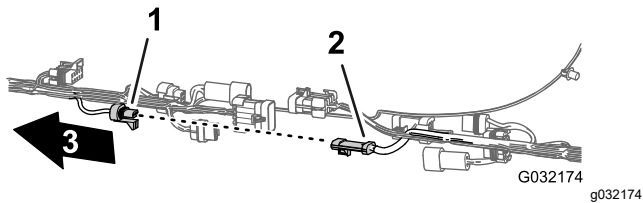

**Figure 16**

1. 3-pin connector—flow meter (rear harness)
2. 3-socket connector—flow meter (front harness)
3. Front of the machine

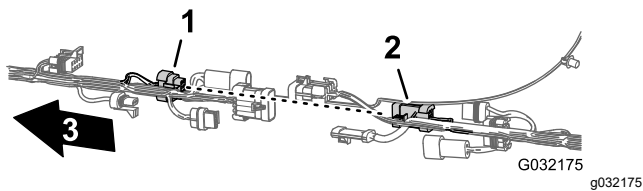

**Figure 17**

1. 8-pin connector—sprayer-harness interconnect (rear harness)
2. 8-socket connector—sprayer-harness interconnect (front harness)
3. Front of the machine

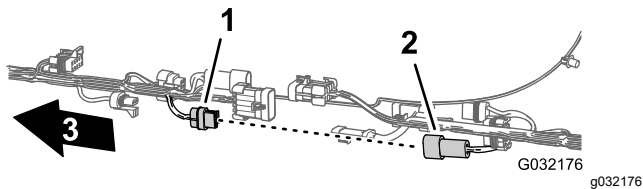

**Figure 18**

1. 2-pin connector—rinse pump (rear harness)
2. 2-socket connector—rinse pump (front harness)
3. Front of the machine

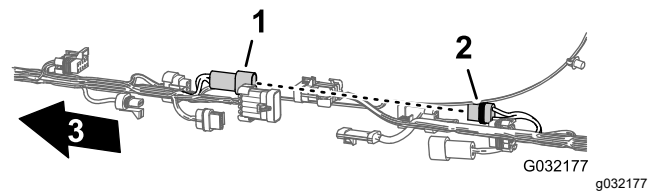

**Figure 19**

1. 2-pin connector—hose reel (front harness)
2. 2-socket connector—hose reel (rear harness)
3. Front of the machine

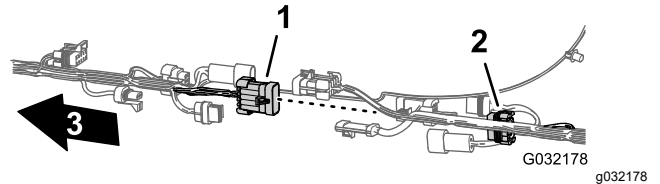

**Figure 20**

1. 10-pin connector—sprayer-harness interconnect (front harness)
2. 10-socket connector—sprayer-harness interconnect (rear harness)
3. Front of the machine

3. Remove the 3 push-in fasteners that secure the rear wire harness to the holes in the right frame tube of the machine (Figure 21).

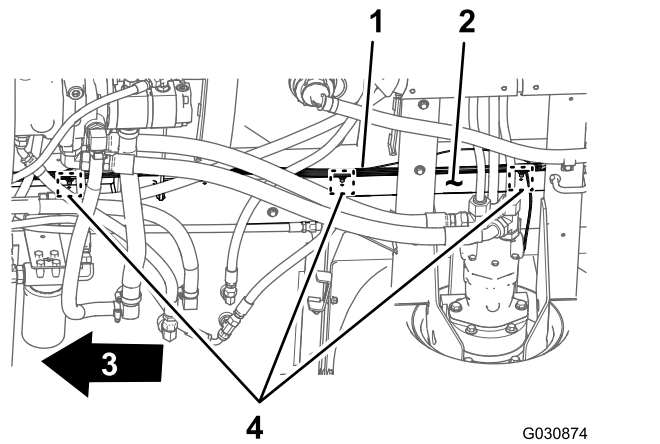

**Figure 21**

1. Rear wire harness
2. Right frame tube
3. Front of the machine
4. Push-in fasteners

# Disconnecting the Connectors for the Components

1. At back of the machine (between the right frame tube and the right fender) disconnect the 3-pin connector of the speed-sensor harness at the right hydraulic-traction motor from the 3-socket connector of the rear, main harness (Figure 22).

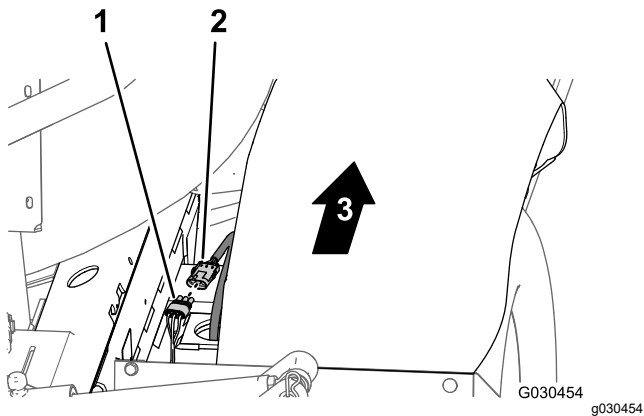

Figure 22

1. 3-socket connector (rear, main harness)
2. 3-pin connector (hydraulic-motor harness)
3. Front of the machine

2. At the back of the manifold mount, disconnect the 3-socket connector from the agitation valve and the 3-socket connectors from the 3 boom-section valves (Figure 23).

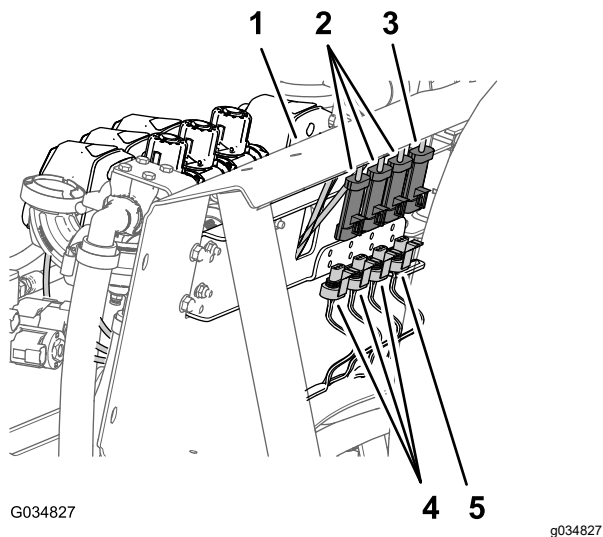

Figure 23

1. Manifold mount
2. 3-socket connectors (boom-section valve harnesses)
3. 3-socket connector (agitation valve harness)
4. 3-pin connectors (machine wire harness—rear)
5. 3-pin connector (machine wire harness—rear)

3. Remove the push-in fasteners that secure the rear wire harness to the holes at the forward side and lower plate of the manifold mount (Figure 24).

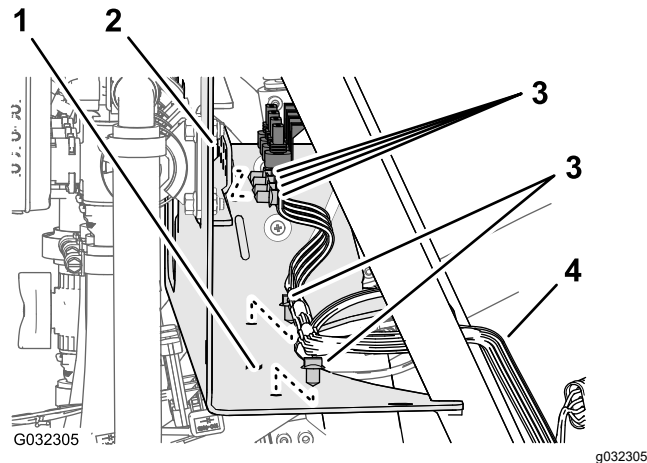

Figure 24

1. Manifold mount (lower side)
2. Manifold mount (forward side)
3. Push-in fasteners
4. Rear wire harness

4. For machines with the ExcelsaRate sprayer system, disconnect the 3-socket connector of the rear-wire-harness from the 3-pin connector of the pressure transducer (Figure 25).

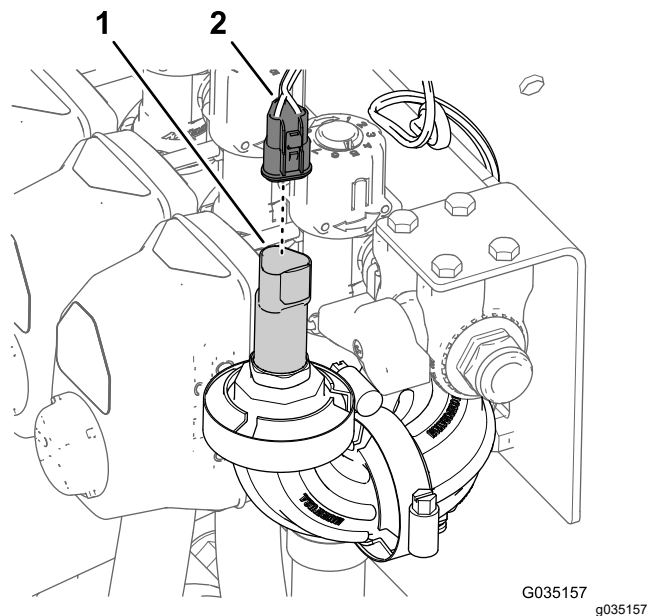
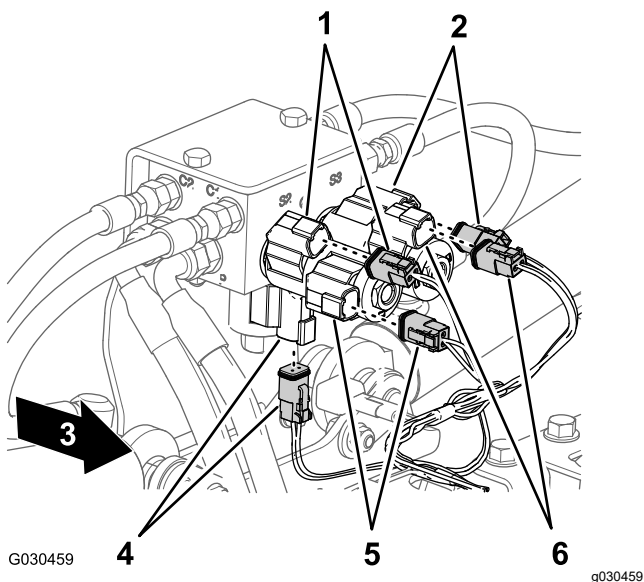

Figure 25

1. 3-pin connector (pressure transducer)
2. 3-socket connector (rear-wire-harness)

5. At the back of the machine, disconnect the following 2-socket connectors (Figure 26) for the lift-cylinder manifold as follows:
  - Right—up solenoid

- Left—up solenoid
- Enable solenoid
- Right—down solenoid
- Left—down solenoid



**Figure 26**

- |   |   |
|---|---|
| 1. Right—up (solenoid and main-harness connector) | 4. Enable (solenoid and main-harness connector)     |
| 2. Left—up (solenoid and main-harness connector)  | 5. Right—down (solenoid and main-harness connector) |
| 3. Front of the machine                           | 6. Left—down (solenoid and main-harness connector)  |

6. At the back of the machine—inboard of the sprayer pump, disconnect the 2-socket connector of the rear, main harness from the 2-pin connector of the relay for the pump (Figure 27).

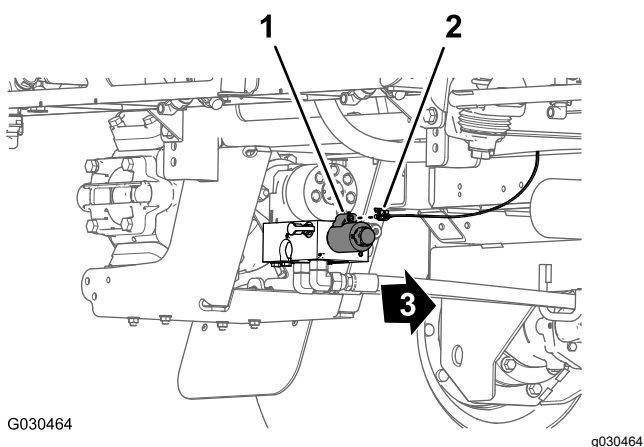

**Figure 27**

- |  |                         |
|--|-------------------------|
| 1. 2-pin connector (pump relay)            | 3. Front of the machine |
| 2. 2-socket connector (rear, main harness) |                         |

7. Remove the push-in fastener that secures the rear wire harness (Figure 28) to the holes in the rear cross tube (rearward of the hydraulic-traction motors).

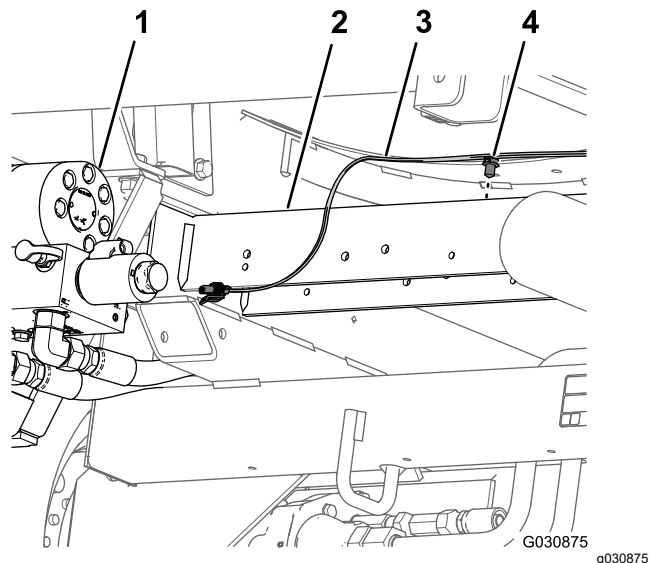

**Figure 28**

- |                    |                      |
|--------------------|----------------------|
| 1. Sprayer pump    | 3. Rear wire harness |
| 2. Rear cross tube | 4. Push-in fastener  |

8. Remove the pressure-sense tube for the dash gauge from the rear wire harness from the machine (Figure 29).

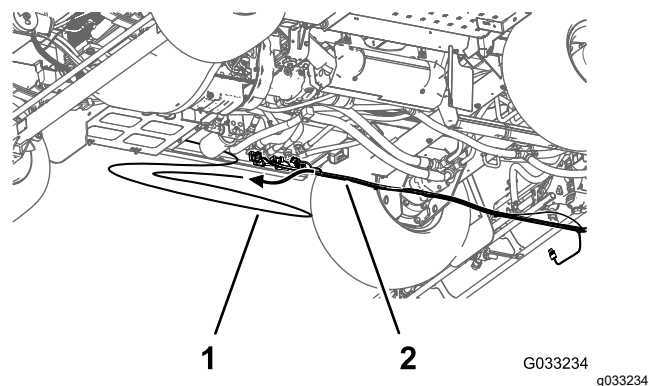

**Figure 29**

- |                                     |                      |
|-------------------------------------|----------------------|
| 1. Pressure-sense tube (dash gauge) | 2. Rear wire harness |
|-------------------------------------|----------------------|

9. Remove the rear wire harness from the machine.

**Note:** You no longer need the rear-main harness that you removed from the machine.

# 8

## Removing the Rate-Control Switch

Parts needed for this procedure:

1	Cable tie
1	Switch plug

### Procedure

1. From under the dash panel of the machine, squeeze the lock tabs of the rate-control switch together and push up the rate-control switch out of the dash panel (Figure 30).

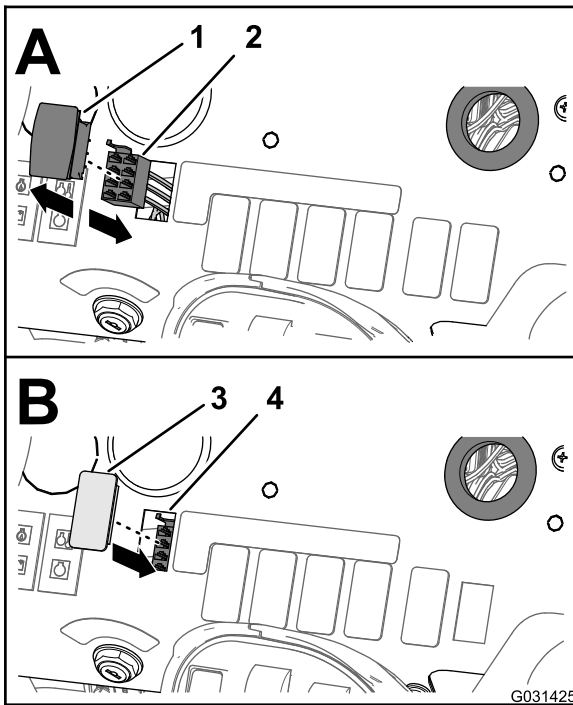

Figure 30

- |                                      |                         |
|--------------------------------------|-------------------------|
| 1. Rate-control switch               | 3. Switch plug          |
| 2. 8-socket connector(front harness) | 4. Opening (dash panel) |

2. Disconnect the 8-socket connector of the front harness of the machine (labeled **Rate Switch**) from the 8-pin connector of the switch (Figure 30).

**Note:** You no longer need the rate switch that you removed from the machine.

3. Route the branch of the front harness for the rate switch through the opening in the dash

and secure the wiring branch against the front harness with a cable tie.

4. Align the switch plug to the opening in the dash panel where you removed the rate switch (Figure 30).
5. Insert the switch plug into the dash panel until the plug snaps into the panel securely (Figure 30).

# 9

## Removing the Boom-Section Valves

Parts needed for this procedure:

1	Fitting cap
3	Cap (quick coupler)
3	Retainer

## Removing the Pressure Transducer from the Section Valve

### Machines with the ExcelsaRate Sprayer System

1. Remove the flange clamp that secures the ported-fitting cap, pressure transducer, and gasket to the 90° elbow at the end of the right-section valve, and remove the cap, transducer, and gasket (Figure 31).

**Note:** Retain the pressure transducer and ported-fitting cap, gasket, and clamp for installation in [Assembling the Pressure Transducer to the Manifold \(page 28\)](#).

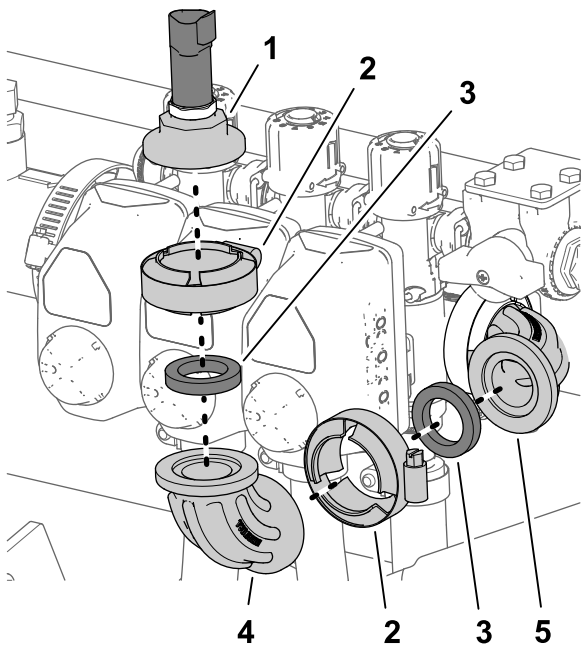

Figure 31

g187815

- |   |   |
|---|---|
| 1. Pressure transducer and ported-fitting cap | 4. 90° elbow (non-ported—right-section valve) |
| 2. Flange clamp                               | 5. Ported 90° elbow                           |
| 3. Gasket                                     |   |

- Remove the flange clamp, 90° elbow (non-ported), and gasket from the ported 90° elbow (Figure 31).

**Note:** Retain the flange clamp and gasket for installation in 3.

- Align the fitting cap, and gasket to the flange of the 90° elbow at the end of the right-section valve (Figure 31).

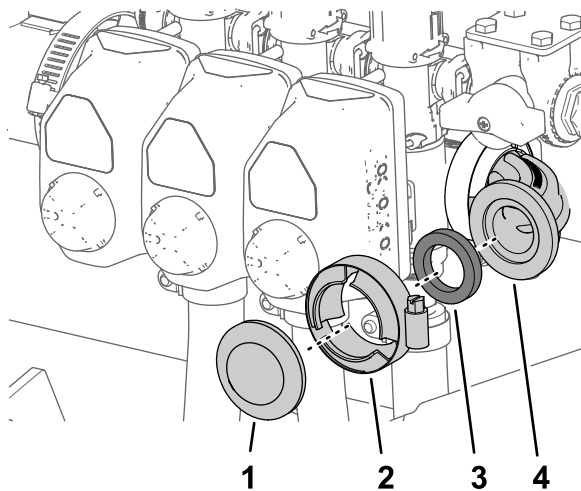

Figure 32

g187813

- |                 |                     |
|-----------------|---------------------|
| 1. Fitting cap  | 3. Gasket           |
| 2. Flange clamp | 4. Ported 90° elbow |

- Secure the fitting cap and gasket to the 90° elbow with the flange clamp (Figure 31).

## Removing the Coupling Tube and Reducer Adapter

- Loosen the 4 flange-head bolts (1/4 x 3/4 inch) and 4 flange locknuts (1/4 inch) that secure the 3 section valves to the manifold mount (Figure 33).

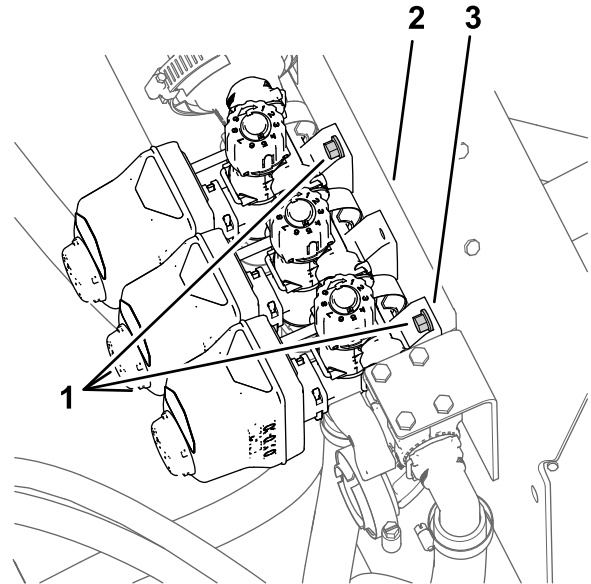

Figure 33

g187814

- |                                       |                   |
|---------------------------------------|-------------------|
| 1. Flange-head bolts (1/4 x 3/4 inch) | 3. Manifold mount |
| 2. Valve housing (section valve)      |                   |

- For machines **without** the ExcelaRate sprayer system, remove the coupling tube as follows:

- Remove the 2 flange clamps that secure the coupling tube to the reducer adapters at the master-control valve and left boom-section valve (Figure 34).

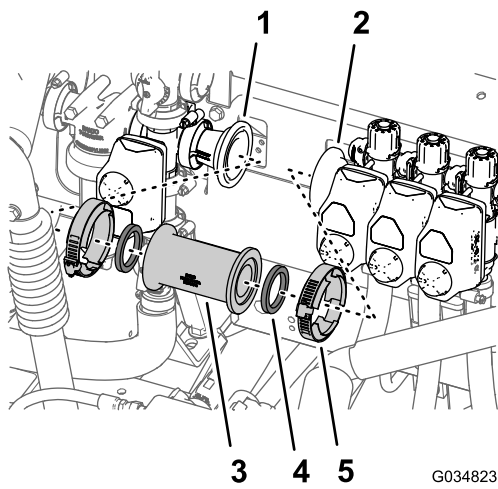

**Figure 34**

- |   |                 |
|---|-----------------|
| 1. Reducer adapter (at the master-control valve)    | 4. Gasket       |
| 2. Reducer adapter (at the left boom-section valve) | 5. Flange clamp |
| 3. Coupling tube                                    |                 |

G034823

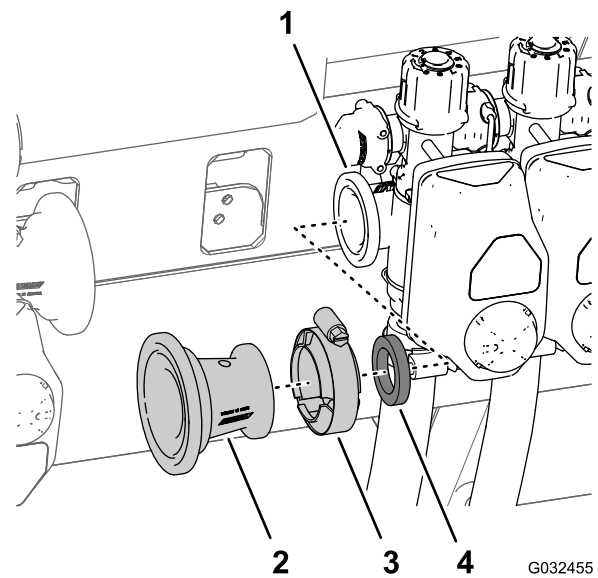

**Figure 35**

- |                                     |  |
|-------------------------------------|--|
| 1. Flange (left boom-section valve) | 3. Flange clamp 51 mm (2 inches)         |
| 2. Reducer adapter                  | 4. Gasket (1-5/16 inch outside diameter) |

G032455  
g032455

- B. Remove the straight coupler and 2 gaskets from the machine ([Figure 34](#)).

**Note:** Retain clamps and gaskets for installation in steps [1A](#) and [1B](#) of [Assembling the Flow Meter \(page 27\)](#).

- C. Remove the flange clamp 76 mm (3 inches) that secures the reducer adapter and gasket (2-1/4 inches) to the flange of the left boom-section valve, and remove the adapter, clamp and gasket from the machine ([Figure 35](#)).

**Note:** Retain reducer adapter for installation in steps [1C](#) of [Assembling the Flow Meter \(page 27\)](#).

3. For machines **with** the ExcelsaRate sprayer system, remove the flange clamp and gasket that secures the reducer adapter to the left boom-section valve ([Figure 36](#)).

**Note:** Do not remove the reducer adapter or the flow meter.

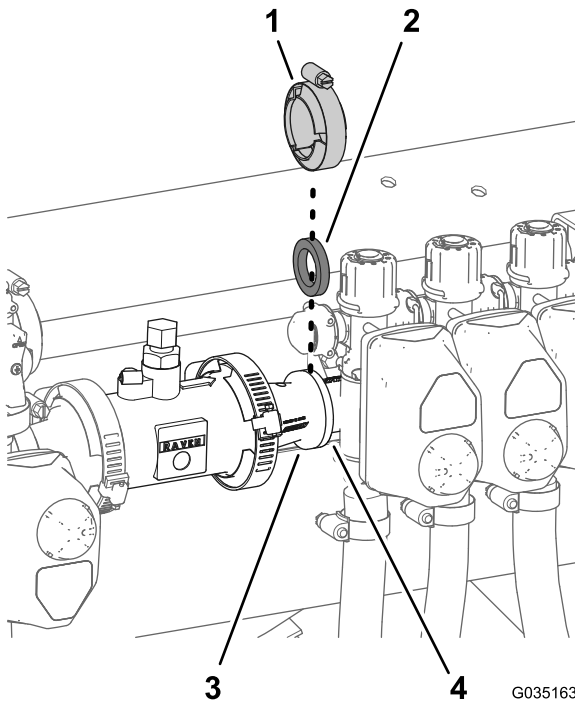
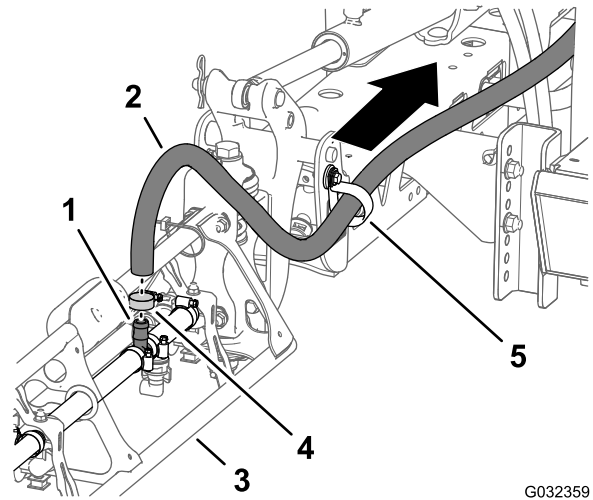

**Figure 36**

- |  |                                     |
|--|-------------------------------------|
| 1. Flange clamp 51 mm (2 inches)         | 3. Reducer adapter                  |
| 2. Gasket (1-5/16 inch outside diameter) | 4. Flange (left boom-section valve) |

## Removing the Boom-Section Hoses

- At the outer-boom section, remove the hose clamp that secures the supply hose for the boom section to the barbed T-fitting ([Figure 37](#)).



**Figure 37**

- |                                     |               |
|-------------------------------------|---------------|
| 1. Barbed T-fitting                 | 4. Hose clamp |
| 2. Supply hose (outer-boom section) | 5. R-clamp    |
| 3. Outer-boom section               |               |

- Remove the hose from the T-fitting ([Figure 37](#)).
- Remove the free end of the hose from the R-clamp ([Figure 37](#)).
- Repeat steps 1 through 3 for the supply hose at the other outer-boom section.
- Under the center-boom section, remove the hose clamp that secures the supply hose for the boom section to the barbed T-fitting ([Figure 38](#)).

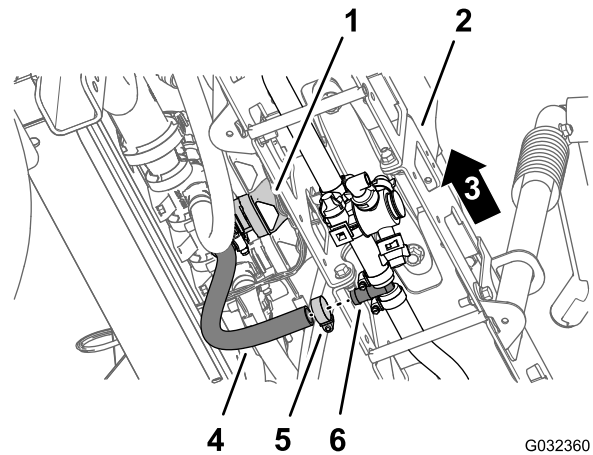
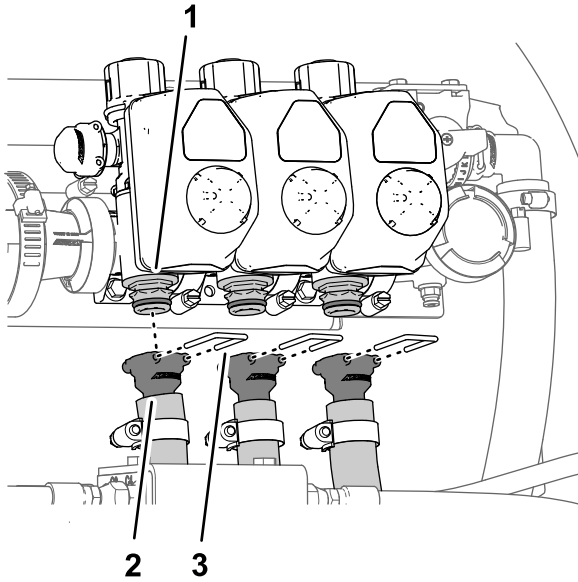

**Figure 38**

- |                              |                               |
|------------------------------|-------------------------------|
| 1. Center boom-section valve | 4. Hose (center-boom section) |
| 2. Center-boom section       | 5. Hose clamp                 |
| 3. Left side of the machine  | 6. Barbed T-fitting           |

- Remove the retainers that secure the straight barbed fittings to the quick disconnect fittings of the left, center, and right boom-section valves ([Figure 39](#)).

**Note:** Retain the retainers for installation in [Assembling the Hoses to Nozzle Valves 7 through 10](#) (page 37).



**Figure 39**

g187838

1. Quick-disconnect fitting (boom-section valve)
2. Straight barbed fitting
3. Retainer

7. Remove the hoses for the left, center, and right boom-section valves from the machine ([Figure 39](#)).

**Note:** You no longer need the hoses for the left, center, and right boom-section valves.

## Removing the Bypass Hoses

1. At the lower end of the upper bypass hose, remove the flange-head bolt (5/16 x 3/4 inch), washer (5/16 inch), and R-clamp that secures the upper bypass hose to the rear-saddle plate of the machine ([Figure 40](#) and [Figure 41](#)).

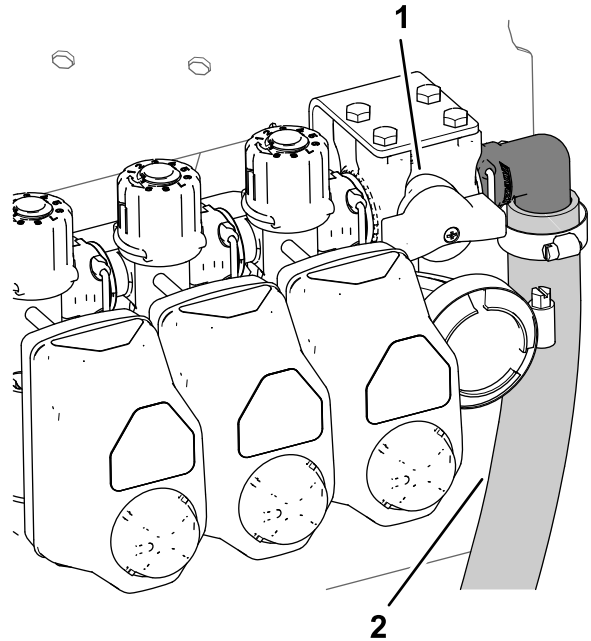

**Figure 40**

g187826

1. Bypass-shutoff valve
2. Upper bypass hose

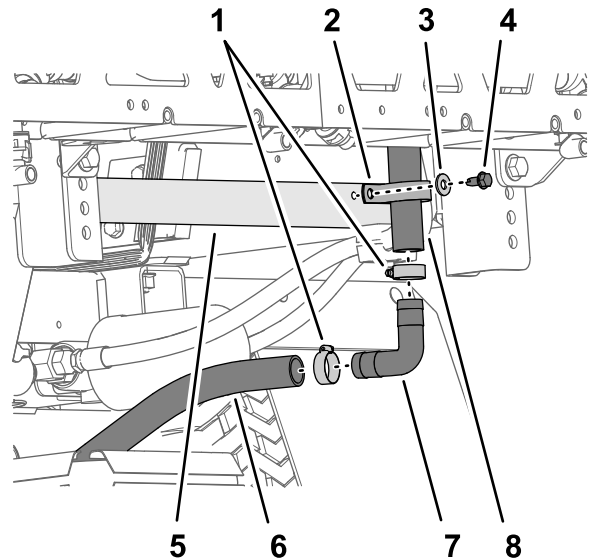
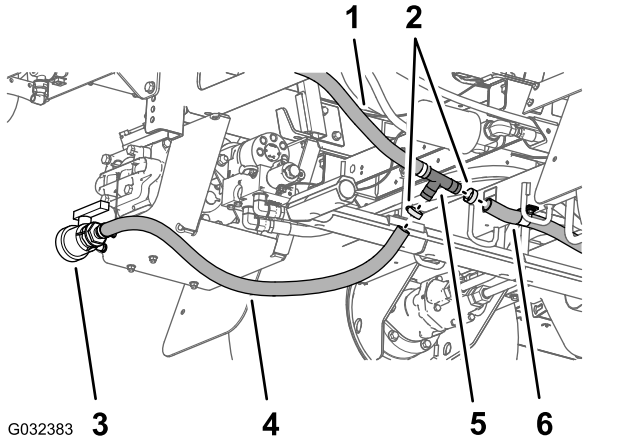

**Figure 41**

g189630

1. Hose clamp
2. R-clamp
3. Washer (5/16 inch)
4. Flange-head bolt (5/16 x 3/4 inch)
5. Rear-saddle plate (chassis frame)
6. Lower bypass hose
7. 90° barbed fitting
8. Upper bypass hose

- Remove the 2 hose clamps that secure the upper bypass hose and the lower bypass hose to the 90° barbed fitting (Figure 41).
  - Remove the 90° barbed fitting from the hoses (Figure 41).
- Note:** Retain the 90° barbed fitting and 2 clamps for installation in steps 8 and 9.
- Remove the hose clamps that secure the drain-valve hose and the rear tank-drain hose to the barbed T-fitting (Figure 42 and Figure 43).



**Figure 42**  
2016 Machine

- |                      |                         |
|----------------------|-------------------------|
| 1. Lower bypass hose | 4. Drain-valve hose     |
| 2. Hose clamp        | 5. Barbed T-fitting     |
| 3. Drain valve       | 6. Rear tank-drain hose |

- Remove the T-fitting from the drain-valve hose from the rear tank-drain hose (Figure 42 and Figure 43).
- Remove the retainer that secures the 90° barbed fitting of the bypass hose to the quick-disconnect fitting of the bypass valve at the right boom-section valve, and separate the hose and valve fittings (Figure 44).

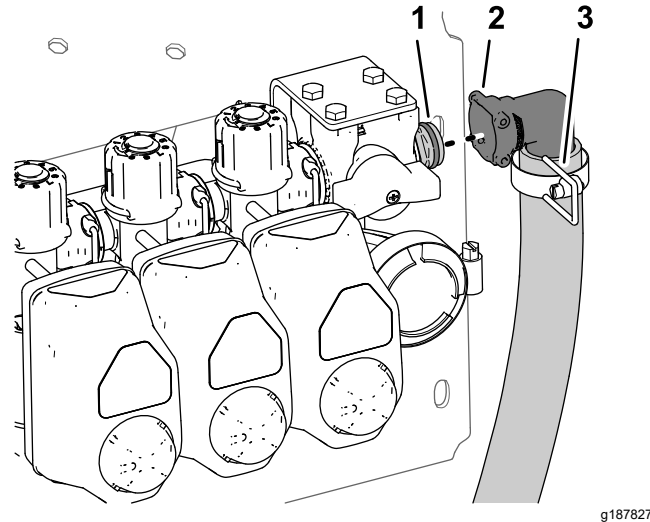
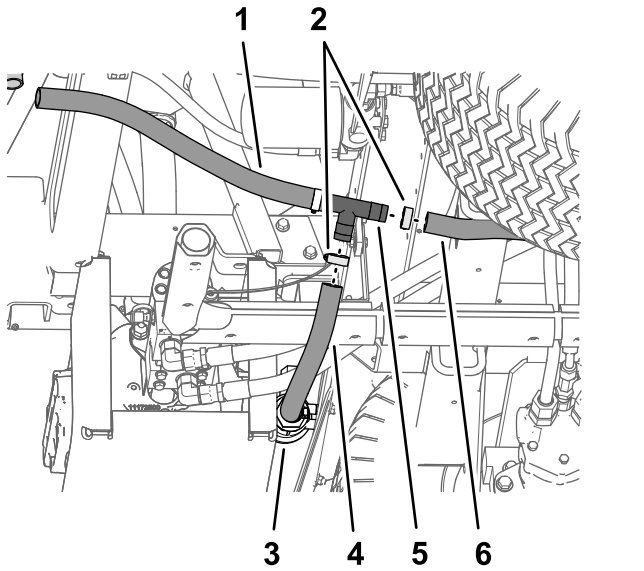

**Figure 44**

- |  |             |
|--|-------------|
| 1. Quick-disconnect fitting (bypass-shutoff valve) | 3. Retainer |
| 2. 90° barbed fitting                              |             |

- Remove the upper and lower bypass hoses from the machine (Figure 45).

**Note:** You no longer need the shutoff valve, T-fitting, upper bypass hose, and lower bypass hose.



**Figure 43**  
2017 and later machine

- |                      |                         |
|----------------------|-------------------------|
| 1. Lower bypass hose | 4. Drain-valve hose     |
| 2. Hose clamp        | 5. Barbed T-fitting     |
| 3. Drain valve       | 6. Rear tank-drain hose |

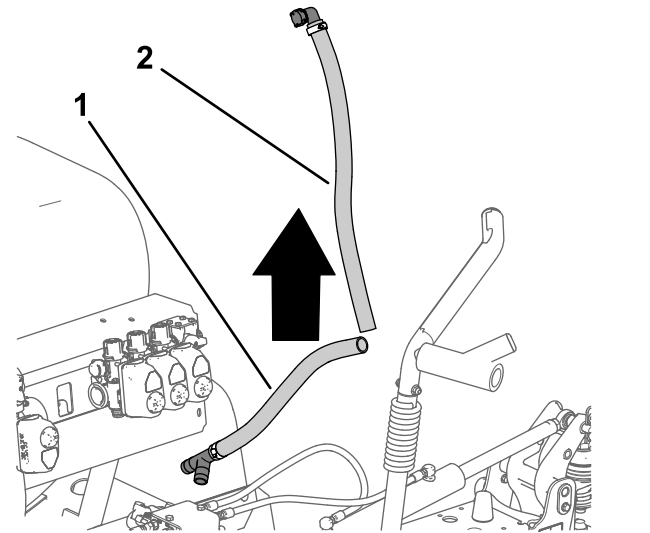

**Figure 45**

- |                      |                      |
|----------------------|----------------------|
| 1. Lower bypass hose | 2. Upper bypass hose |
|----------------------|----------------------|

- Insert the 90° barbed fitting that you removed in step 3 into the drain-valve hose and the rear tank-drain hose (Figure 46 and Figure 47).

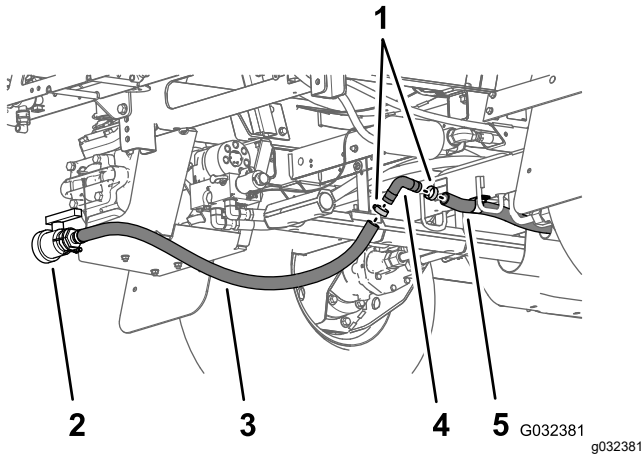

**Figure 46**  
2016 Machines

- |                     |                         |
|---------------------|-------------------------|
| 1. Hose clamp       | 4. 90° barbed fitting   |
| 2. Drain valve      | 5. Rear tank-drain hose |
| 3. Drain-valve hose |                         |

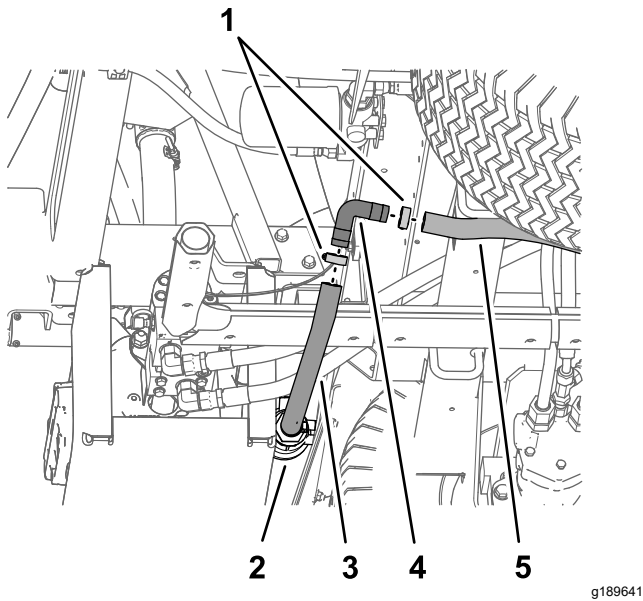

**Figure 47**  
2017 and later machines

- |                     |                         |
|---------------------|-------------------------|
| 1. Hose clamp       | 4. 90° barbed fitting   |
| 2. Drain valve      | 5. Rear tank-drain hose |
| 3. Drain-valve hose |                         |

- Secure the 90° barbed fitting and drain hoses with the 2 hose clamps that you removed in step 2 (Figure 46 and Figure 47).

## Removing the Valve Actuator

- Remove the retainer that secures the actuator to the manifold valve of the section valve assembly (Figure 48).

**Note:** Squeeze the 2 legs of the retainer together while pushing it down.

**Note:** Retain the actuator and retainer for installation in steps 8 and 9 of [Removing the Bypass Shutoff Valve and Installing the Bypass Valve with Caps](#) (page 24).

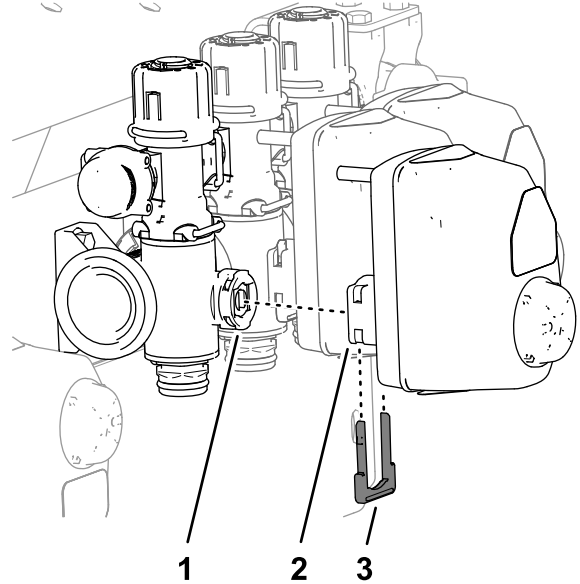

**Figure 48**

- |                               |             |
|-------------------------------|-------------|
| 1. Stem port (manifold valve) | 3. Retainer |
| 2. Actuator (section valve)   |             |

- Remove the actuator from the manifold valve (Figure 48).
- Repeat steps 1 and 2 for the 2 other valve actuators.

## Removing the Bypass Shutoff Valve and Installing the Bypass Valve with Caps

- Remove the 4 bolts (6 x 12 mm) that secure the bypass-shutoff valve to the valve-support bracket (Figure 49).
- Remove the retainer that secures the bypass-shutoff valve to the bypass valve for the right boom section valve, and remove the shutoff valve (Figure 49).

**Note:** You no longer need the bypass-shutoff valve and the 4 bolts (6 x 12 mm).

- Remove the 3 retainers that secure the 3 bypass valves to the 3 manifold valves (Figure 49).

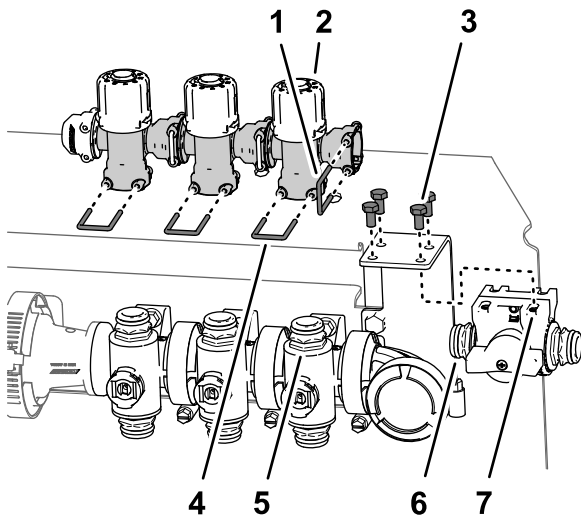

**Figure 49**

g187902

- |                                   |   |
|-----------------------------------|---|
| 1. Retainer                       | 5. Quick coupler (bypass-shutoff valve) |
| 2. Bypass valves                  | 6. Bypass-shutoff valve                 |
| 3. Bolt (6 x 12 mm)               | 7. Valve mount                          |
| 4. Quick coupler (manifold valve) |   |

4. Lift the 3 bypass valves from the 3 quick couplers of the manifold valves (Figure 49).

**Note:** You no longer need the bypass valves.

5. Lubricate the upper and lower O-rings on the quick coupler of the manifold valve with the grease provided with the quick-coupler cap (Figure 50).

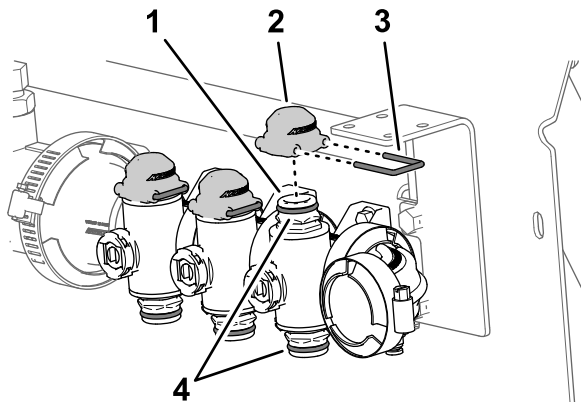

**Figure 50**

g187927

- |                                   |             |
|-----------------------------------|-------------|
| 1. Quick coupler (manifold valve) | 3. Retainer |
| 2. Cap (quick coupler)            | 4. O-rings  |

6. Assemble the 3 caps for the quick couplers onto the 3 quick couplers for the manifold valves (Figure 50).

7. Secure the 3 caps to the 3 quick couplers with the 3 retainers (Figure 50).
8. Align the coupler of the section valve actuator that you removed in step 2 of [Removing the Valve Actuator](#) (page 24) with the stem port of the manifold valve (Figure 51).

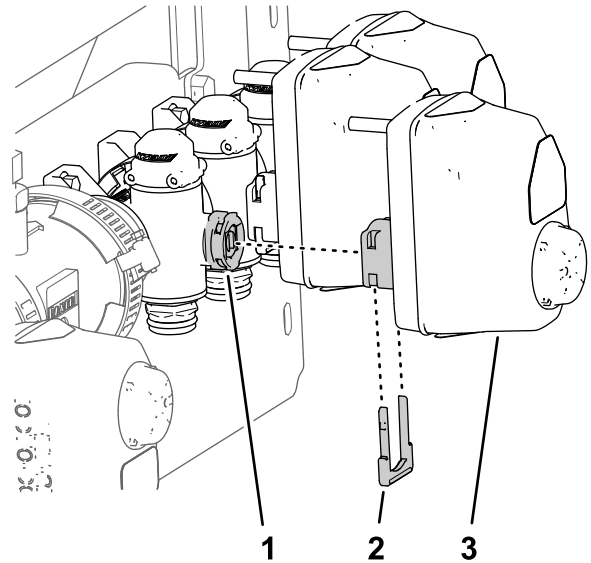

**Figure 51**

g187925

- |                                     |                               |
|-------------------------------------|-------------------------------|
| 1. Retainer                         | 3. Stem port (manifold valve) |
| 2. Coupler (section-valve actuator) |                               |

9. Secure the section valve actuator to the manifold valve with a retainer (Figure 51) that you removed in step 1 of [Removing the Valve Actuator](#) (page 24).

## Disassembling the Boom-Section Valves from the Manifold Mount

**Note:** You will add the boom-section valves to the valves for the 10-valve system in [Assembling Sprayer Valves 8, 9, and 10 to the Valve Mount](#) (page 31).

1. Remove the 2 flange-head bolts (1/4 x 3/4 inch) and 2 locknuts (1/4 inch) that secure the right boom-section valve to the manifold mount (Figure 52).

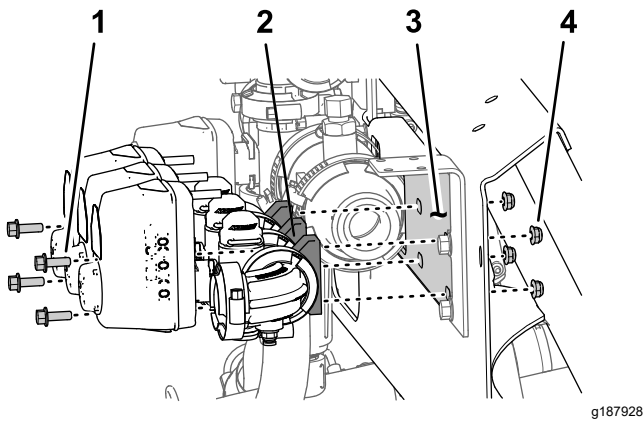

**Figure 52**

- |                                       |                       |
|---------------------------------------|-----------------------|
| 1. Flange-head bolt (5/16 x 3/4 inch) | 3. Manifold mount     |
| 2. Boom-section valve                 | 4. Locknut (1/4 inch) |

- Remove the 2 flange-head bolts (1/4 x 3/4 inch) and 2 locknuts (1/4 inch) that secure the left boom-section valve to the manifold mount (Figure 52).
- Remove the boom-section valves from the manifold mount and set aside the valves (Figure 52).

**Note:** Retrain the boom-section valves for installation in steps 1 of [Assembling Sprayer Valves 8, 9, and 10 to the Valve Mount](#) (page 31). Discard the 4 flange-head bolts and 4 locknuts.

- Remove the 6 decals from the 3 boom-section valves (Figure 53).

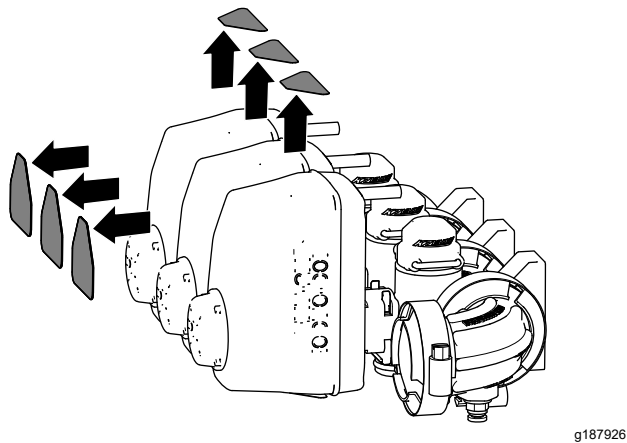

**Figure 53**

- Remove the 2 flange-head bolts (5/16 x 1 inch) and 2 flange locknuts (5/16 inch) that secure the support bracket for the bypass-shutoff valve to the manifold mount (A of Figure 54), and remove the shutoff-valve bracket.

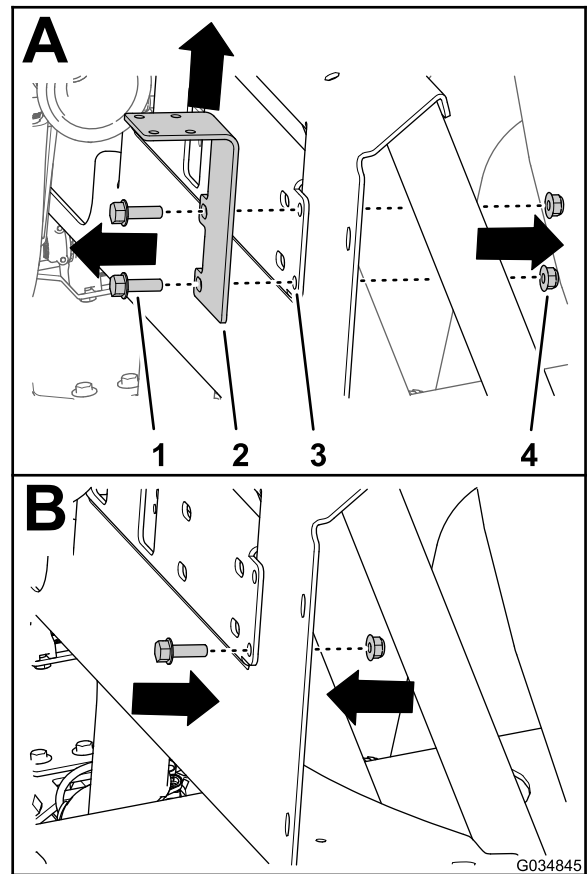

**Figure 54**

- |   |                                |
|---|--------------------------------|
| 1. Flange-head bolt (5/16 x 1 inch)       | 3. Manifold mount              |
| 2. Support bracket (bypass-shutoff valve) | 4. Flange locknuts (5/16 inch) |

- Assemble a flange-head bolt (5/16 x 1 inch) and flange locknut (5/16 inch) to the manifold mount (B of Figure 54) at the lower hole position for the shutoff-valve bracket that you removed in step 5.

**Note:** Retain the other flange-head bolt and flange locknut for installation in step 3 of [Installing the Pressure Transducer onto the Machine](#) (page 29).

- Torque the flange bolt and flange nut to 1978 to 2542 N·cm (175 to 225 in-lb).

# 10

## Installing the Flow Meter and Pressure Transducer

### Parts needed for this procedure:

1	Flow meter (for 2016 machines without the ExcelaRate sprayer system only)—not included in this kit; order Toro Part No. 106-1038.
1	Flange clamp 51 mm (2 inches)
1	Gasket (1-5/16 inch outside diameter)
1	Barbed-flange fitting (1 inch)
1	Hose (1 x 7-1/4 inches)
3	Hose clamp
1	Pressure transducer (for 2016 machines without the ExcelaRate sprayer system only)—not included in this kit; order Toro Part No. 130-8202.
1	Fitting cap—ported (for 2016 machines without the ExcelaRate sprayer system only)—not included in this kit; order Toro Part No. 127-1185.
1	Manifold
1	Hose (1 x 8-1/2 inches)
1	R-clamp

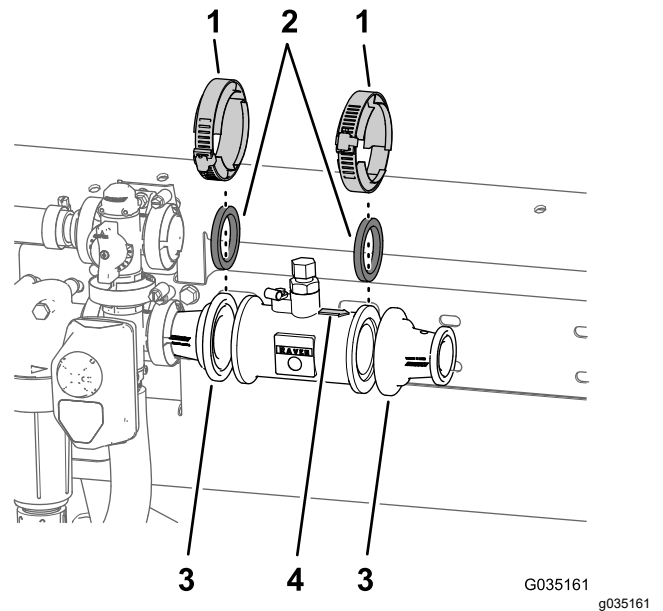
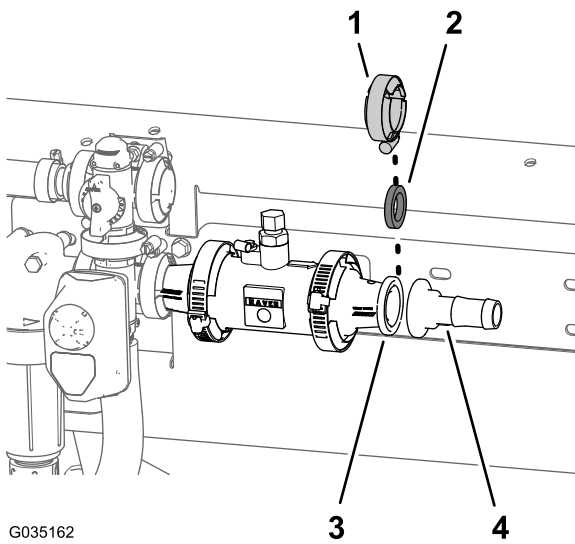

**Figure 55**

1. Flange clamp 76 mm (3 inches)
2. Gasket (2-1/4 inch outside diameter)
3. Reducer adapter (76 mm (3 inches))
4. Directional arrow (flow meter)

### Assembling the Flow Meter

1. For machines **without** the ExcelaRate sprayer system, perform the following steps:
  - A. Align the gasket (2-1/4 inches) that you removed in step 2 B of [Removing the Coupling Tube and Reducer Adapter \(page 19\)](#) between the flow meter and the reducer adapter that is installed at the right side of the master-control valve ([Figure 55](#)).
  - B. Loosely assemble the gasket, flow meter, and reducer adapter ([Figure 55](#)) with a flange clamp 76 mm (3 inches) that you removed in step 2A of [Removing the Coupling Tube and Reducer Adapter \(page 19\)](#).
  - C. Align the gasket (2-1/4 inches) and reducer adapter that you removed in step 2C of [Removing the Coupling Tube and Reducer Adapter \(page 19\)](#) to the end of the flow meter to which the directional arrow points ([Figure 55](#)).
  - D. Assemble the gasket, flow meter, and reducer adapter ([Figure 55](#)) with a flange clamp 76 mm (3 inches) that you removed in step 2A of [Removing the Coupling Tube and Reducer Adapter \(page 19\)](#).
2. Align the gasket (1-5/16 inch) that you removed in step and barbed hose fitting to the end of the reducer adapter ([Figure 56](#)).



**Figure 56**

- |  |                                   |
|--|-----------------------------------|
| 1. Flange clamp 51 mm (2 inches)         | 3. Reducer adapter                |
| 2. Gasket (1-5/16 inch outside diameter) | 4. Barbed-flange fitting (1 inch) |

- Secure the hose fitting and gasket to the adapter (Figure 56) with the flange clamp 51 mm (2 inches).

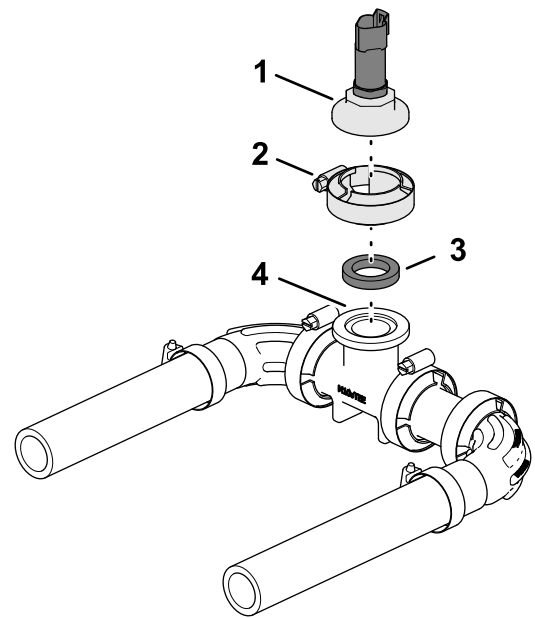

**Figure 57**

- |   |                         |
|---|-------------------------|
| 1. Pressure transducer and ported-fitting cap | 3. Gasket               |
| 2. Flange clamp                               | 4. T-fitting (manifold) |

- Secure the fitting cap and gasket to the T-fitting with the flange clamp (Figure 57).

## Assembling the Pressure Transducer to the Manifold

- Align the ported-fitting cap with pressure transducer and gasket to the T-fitting flange of the manifold (Figure 57).

## Installing the Pressure-Transducer Manifold

- Assemble the hose (1 x 7-1/4 inches) onto the barbed elbow fitting of the pressure transducer and manifold as shown in Figure 58.

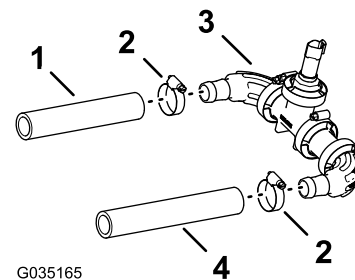

**Figure 58**

- |                            |                                     |
|----------------------------|-------------------------------------|
| 1. Hose (1 x 7-1/4 inches) | 3. Pressure transducer and manifold |
| 2. Hose clamp              | 4. Hose (1 x 8-1/2 inches)          |

- Secure the hose and barbed fittings with a hose clamp (Figure 58).
- Assemble the hose (1 x 8-1/2 inches) onto the other barbed elbow-fitting of the pressure transducer and manifold as shown in Figure 58.
- Secure the hose and barbed fitting with a hose clamp (Figure 58).

# Installing the Pressure Transducer onto the Machine

1. Assemble the hose (1 x 7-1/4 inches) that is attached to the pressure transducer and manifold (Figure 59) onto the barbed-flange fitting (1 inch).

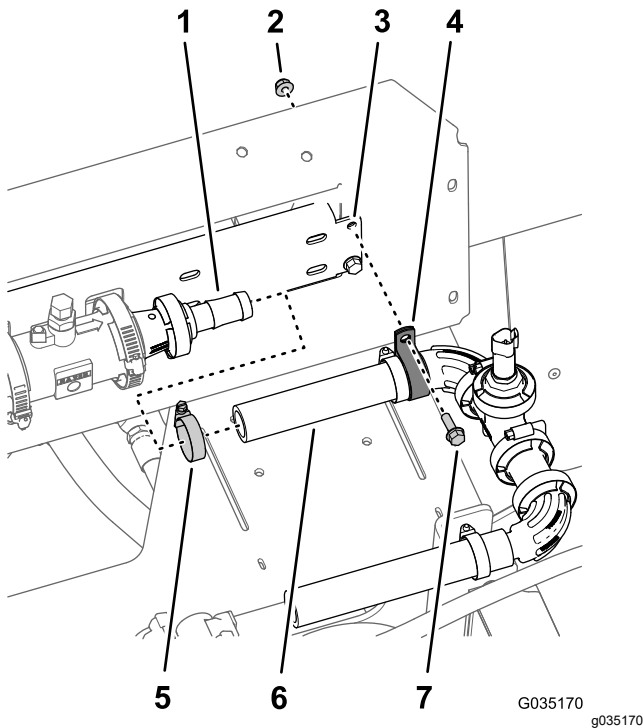

Figure 59

- |                                   |                                      |
|-----------------------------------|--------------------------------------|
| 1. Barbed-flange fitting (1 inch) | 5. Hose clamp                        |
| 2. Flange locknut (1/4 inch)      | 6. Hose (1 x 7-1/4 inches)           |
| 3. Slot (Manifold mount)          | 7. Flange-head bolt (1/4 x 3/4 inch) |
| 4. R-clamp                        |                                      |

2. Loosely secure the hose to the barbed-flange fitting with a hose clamp (Figure 59).

**Note:** You will tighten the hose clamp at the left end of the hose (1 x 7-1/4 inches) in [Assembling the Hose to the Sprayer Valve Manifold](#) (page 31).

3. Secure the pressure transducer and manifold to the slot in the manifold mount with a R-clamp (Figure 59) and the flange-head bolt (1/4 x 3/4 inch), and flange locknut (1/4 inch) that you removed in step 5 of [Disassembling the Boom-Section Valves from the Manifold Mount](#) (page 25).

# 11

## Installing the Valve Mount and Sprayer Valves

Parts needed for this procedure:

1	Valve mount and sprayer-valve assembly
4	Bolt (4 x 10 mm)
1	Sprayer controller—GeoLink precision spray system kit (Model 41633 or Model 41634)
4	Flange locknut (4 mm)
8	Flange-head bolts (5/16 x 3/4 inch)
8	Flange locknuts (5/16 inch)
1	Hose clamp
2	Flange head bolt (1/4 x 3/4 inch)
2	Flange locknut (1/4 inch)

## Assembling the Sprayer Controller to the Valve Mount

1. Align the sprayer controller the forward side of the valve mount with the 40-pin connector outward (Figure 60).

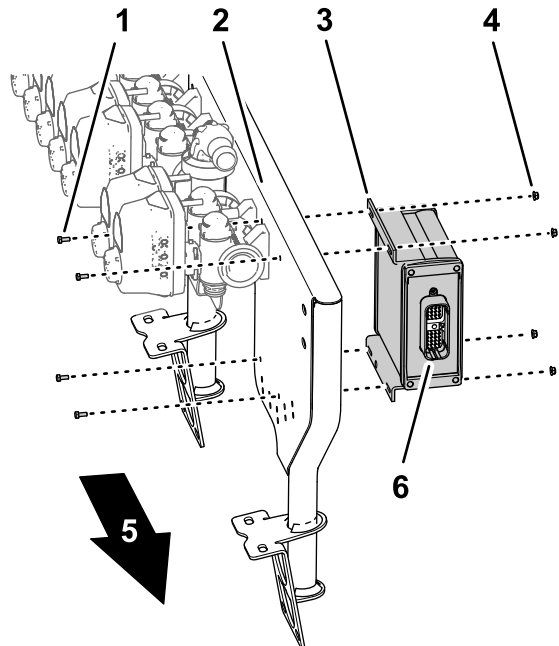

Figure 60

- |                       |                              |
|-----------------------|------------------------------|
| 1. Bolt (4 x 10 mm)   | 4. Flange locknut (4 mm)     |
| 2. 10-valve mount     | 5. Right side of the machine |
| 3. Sprayer controller | 6. 40-pin connector          |

- Assemble the sprayer controller to the valve mount (Figure 60) with the 4 bolts (4 x 10 mm) and 4 flange locknuts (4 mm).
- Torque the bolts and nuts to 234 to 286 N·cm (21 to 25 to in-lb).

## Assembling the Valve Mount and Sprayer Valve Assembly to the Machine

Lifting-equipment capacity: 23 kg (50 lb)

- Using lifting equipment with the specified capacity, lift the valve mount and sprayer valve assembly and align it over the center-boom section (Figure 61).

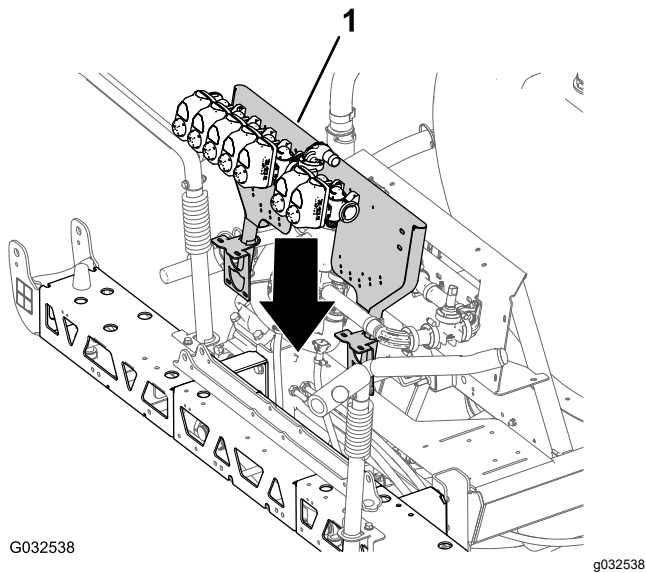

Figure 61

- Valve Mount and Sprayer-Valve Assembly

- Align the holes on the mount bracket of the valve mount to the holes on the truss frame of the center-boom section (Figure 62).

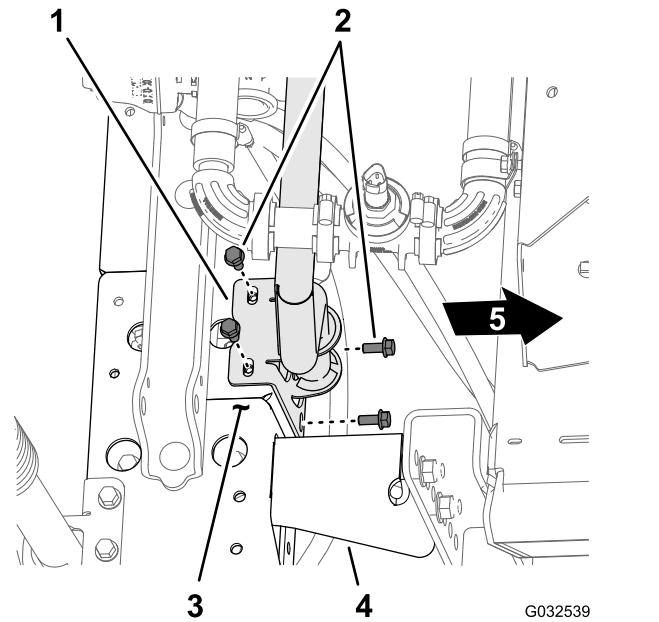

Figure 62

- Mount bracket (valve mount)
- Flange head bolt (5/16 x 3/4 inch)
- Truss frame (center-boom section)
- Support bracket
- Front of the machine

- Assemble the valve mount to the truss frame (Figure 62 and Figure 63) with 4 bolts (5/16 x 3/4 inch) and 4 flange locknuts (5/16 inch).

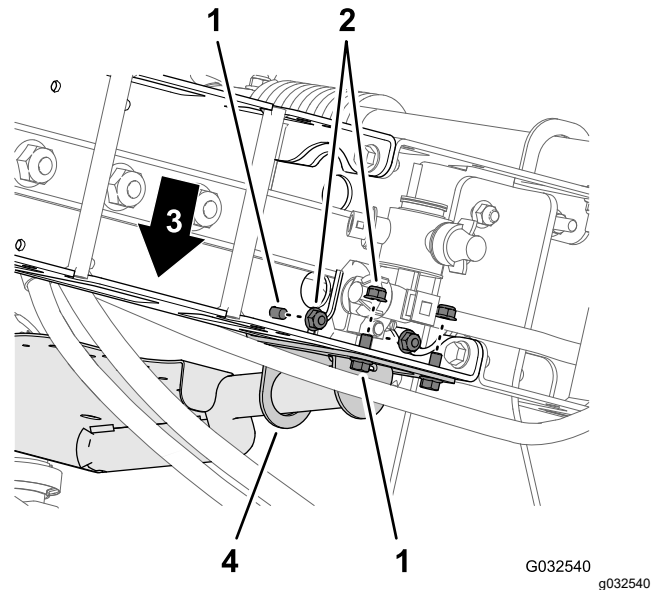

Figure 63

- Flange head bolt (5/16 x 3/4 inch)
- Flange locknuts (5/16 inch)
- Front of the machine
- Mount bracket (valve mount)

4. Repeat steps 2 through 3 for the other mount bracket of the valve mount at the other truss frame.
5. Torque the flange-head bolts and flange locknuts to 1978 to 2542 N·cm (175 to 225 in-lb).

## Assembling the Hose to the Sprayer Valve Manifold

1. Assemble the hose (1 x 8-1/2 inches) over the 90° flange fitting (1 inch) as shown in [Figure 64](#).

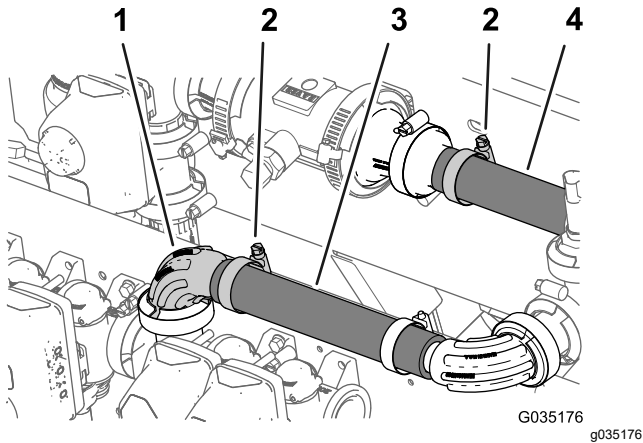

**Figure 64**

- |                                |                            |
|--------------------------------|----------------------------|
| 1. 90° flange fitting (1 inch) | 3. Hose (1 x 8-1/2 inches) |
| 2. Hose clamp                  | 4. Hose (1 x 7-1/4 inches) |

2. Secure the hose to the flange fitting with a hose clamp ([Figure 64](#)).
3. Tighten the hose clamp that secures the hose (1 x 7-1/4 inches) to the barbed-flange fitting (1 inch) that you assembled in [Installing the Pressure Transducer onto the Machine \(page 29\)](#); refer to [Figure 64](#).

## Assembling Sprayer Valves 8, 9, and 10 to the Valve Mount

**Important:** The left boom-section valve that you removed in step 3 of [Disassembling the Boom-Section Valves from the Manifold Mount \(page 25\)](#) is identified as nozzle-valve 8, the center boom-section valve is identified as nozzle-valve 9, and the right boom-section valve is identified as nozzle-valve 10 for the remainder of the GeoLink finishing kit installation instructions.

1. Align the gasket and the flange of the left section valve (identified as nozzle-valve 8) with the flange of nozzle-valve 7 ([Figure 65](#)).

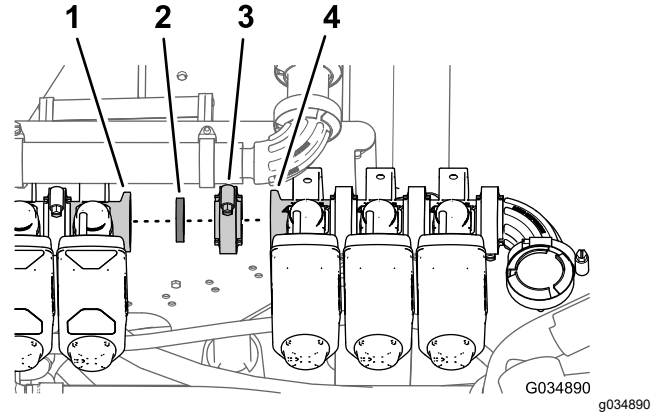

**Figure 65**

- |                            |                            |
|----------------------------|----------------------------|
| 1. Flange (nozzle-valve 7) | 3. Flange clamp            |
| 2. Gasket                  | 4. Flange (nozzle-valve 8) |

2. Loosely secure the gasket and nozzle-valve 8 to nozzle valve 7 with a flange clamp ([Figure 65](#)).
3. Assemble nozzle-valve 10 to the valve mount ([Figure 66](#)) with the 2 flange-head bolts (1/4 x 3/4 inch) and 2 flange locknuts (1/4 inch) that you removed in step 2 of [Disassembling the Boom-Section Valves from the Manifold Mount \(page 25\)](#).

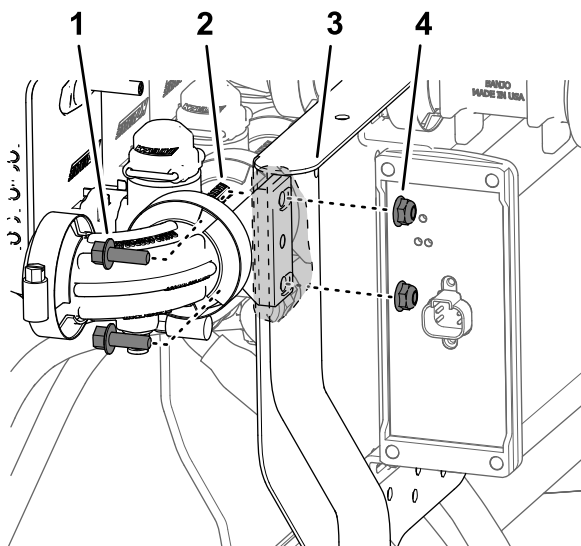

**Figure 66**

1. Flange head bolt (1/4 x 3/4 inch)
2. Nozzle-valve 10
3. Valve mount
4. Flange locknut (1/4 inch)

4. Torque the flange-head bolt and locknut to 1017 to 1234 N·cm (90 to 120 in-lb).
5. Tighten the flange clamp by hand.

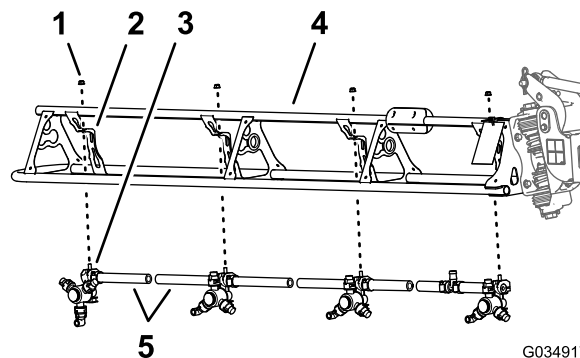

**Figure 67**

1. Flange locknut (5/16 inch)
2. Nozzle support
3. Sprayer nozzle
4. Outer-boom section
5. Hose (3/4 inch inside diameter)

2. Remove the flange locknut (5/16 inch) that secures the sprayer nozzle to the nozzle support (Figure 67).
3. Repeat steps 2 and 6 for the other 3 nozzles.

**Note:** The hex-head bolt (5/16 x 3/4 inch—stainless steel) will separate from the upper clamp half when you open the clamp, retain the bolt for installation.

**Note:** Retain the flange locknut and sprayer nozzle for installation in [Installing the Sprayer Nozzles at the Outer-Boom Sections](#) (page 38).

**Note:** You no longer need the hose barbs and cut sections of hose.

4. Repeat steps 2 through 3 at the other outer-boom section.
5. At the center-boom section, cut the hose between 2 sprayer nozzles (Figure 68).

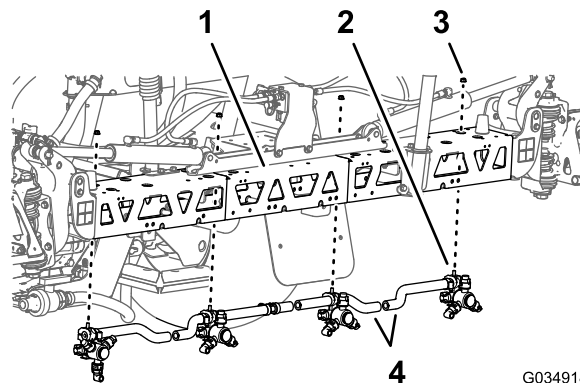

**Figure 68**

1. Center-boom section
2. Sprayer nozzle
3. Flange locknut (5/16 inch)
4. Hose (3/4 inch inside diameter)

# 12

## Removing the Sprayer-Nozzle Hoses for the 3-Section System

No Parts Required

### Procedure

1. At the outer-boom section, cut the hose between 2 sprayer nozzles (Figure 67).

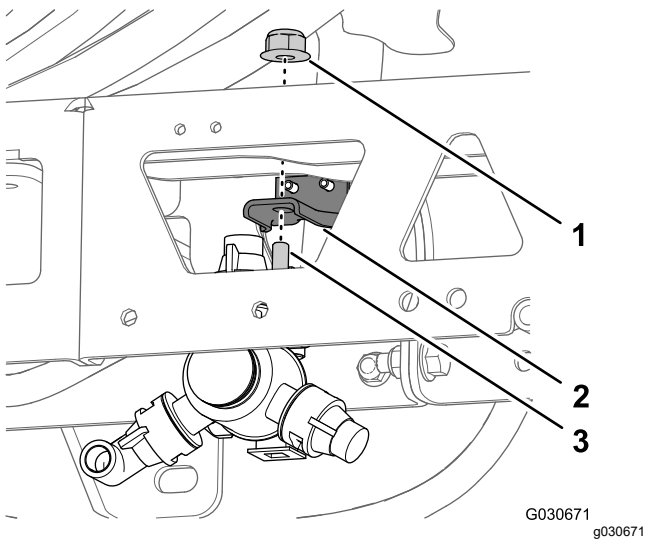

**Figure 69**

- |                           |   |
|---------------------------|---|
| 1. Flange nut (5/16 inch) | 3. Hex-head bolt (5/16 x 3/4 inch—sprayer nozzle) |
| 2. Nozzle mount           |   |

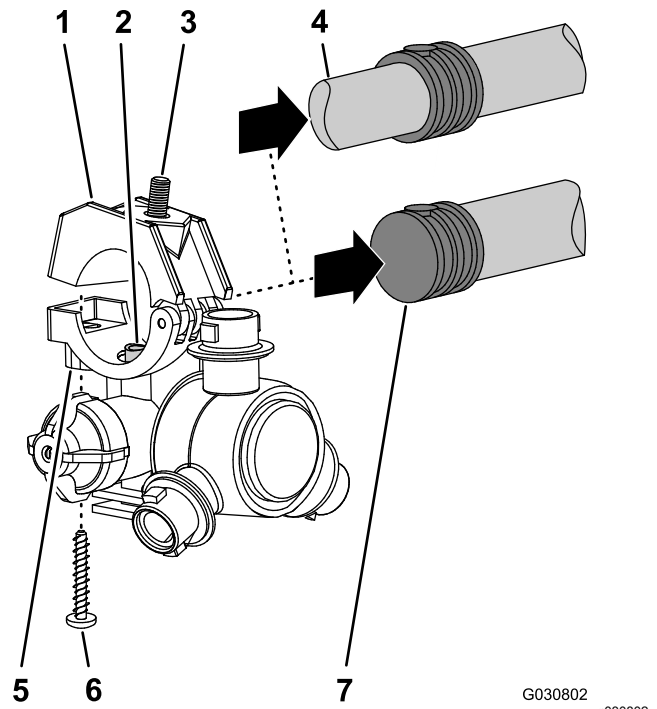

**Figure 70**

6. Remove the flange locknut (5/16 inch) that secures the sprayer nozzle to the nozzle support (Figure 68).
7. Repeat steps 2 and 6 for the other 3 nozzles.
8. Working with the 12 sprayer nozzles that you removed from the outer- and center-boom sections, remove the stainless steel screws (#12 x 1-1/4 inches) that secures the upper clamp halves and the double or single barbed-hose shanks (3/4 inch) to the body of each of the sprayer nozzle, and remove the barbed-hose shanks (Figure 70).

- |  |   |
|--|---|
| 1. Upper clamp half                                | 5. Sprayer-nozzle body                        |
| 2. Transfer tube                                   | 6. Stainless steel screw (#12 x 1-1/4 inches) |
| 3. Hex-head bolt (5/16 x 3/4 inch—stainless steel) | 7. Single barbed-hose shank (3/4 inch hose)   |
| 4. Double barbed-hose shank (3/4 inch hose)        |   |

**Note:** The hex-head bolt (5/16 x 3/4 inch—stainless steel) will separate from the upper clamp half when you open the clamp, retain the bolt for installation.

**Note:** Retain the flange locknut and sprayer nozzle for installation in [Installing the Sprayer Nozzles at the Outer-Boom Sections](#) (page 38).

**Note:** You no longer need the hose barbs and cut sections of hose.

# 13

## Installing the Sprayer-Nozzle Hoses

### Parts needed for this procedure:

2	Supply hose 279 cm (110 inches)
2	Supply hose 234 cm (92 inches)
4	Supply hose 188 cm (74 inches)
2	Supply hose 81 cm (32 inches)
2	R-clamp
2	Double R-clamp
2	Single R-clamp

### Identifying the Sprayer-Nozzle Hose Positions

Identify the supply hoses by length (Figure 71) for each of the sprayer-nozzle position as follows:

#### Sprayer nozzle hose-position table

Sprayer-nozzle positions—left-boom section	Sprayer-nozzle positions—center-boom section	Sprayer-nozzle positions—right-boom section
Sprayer nozzle 1 (nozzle valve 1)—supply hose 279 cm (110 inches)	Sprayer nozzles 5 and 6 (nozzle valve 5)—supply hose 81 cm (32 inches) with 2 branch hoses	Sprayer nozzle 9 (nozzle valve 7)—supply hose 188 cm (74 inches)
Sprayer nozzle 2 (nozzle valve 2)—supply hose 234 cm (92 inches)	Sprayer nozzles 7 and 8 (nozzle valve 6)—supply hose 81 cm (32 inches) with 2 branch hoses	Sprayer nozzle 10 (nozzle valve 8)—supply hose 188 cm (74 inches)
Sprayer nozzle 3 (nozzle valve 3)—supply hose 188 cm (74 inches)		Sprayer nozzle 11 (nozzle valve 9)—supply hose 234 cm (92 inches)
Sprayer nozzle 4 (nozzle valve 4)—supply hose 188 cm (74 inches)		Sprayer nozzle 12 (nozzle valve 10)—supply hose 279 cm (110 inches)

**Note:** Refer to Figure 72 in *Assembling the Hoses to Nozzle Valves 1 through 4* (page 36), Figure 73 in *Assembling the Hoses to Nozzle Valves 5 and 6* (page 36), and Figure 74 in *Assembling the Hoses to Nozzle Valves 7 through 10* (page 37) for the nozzle-valve positions.

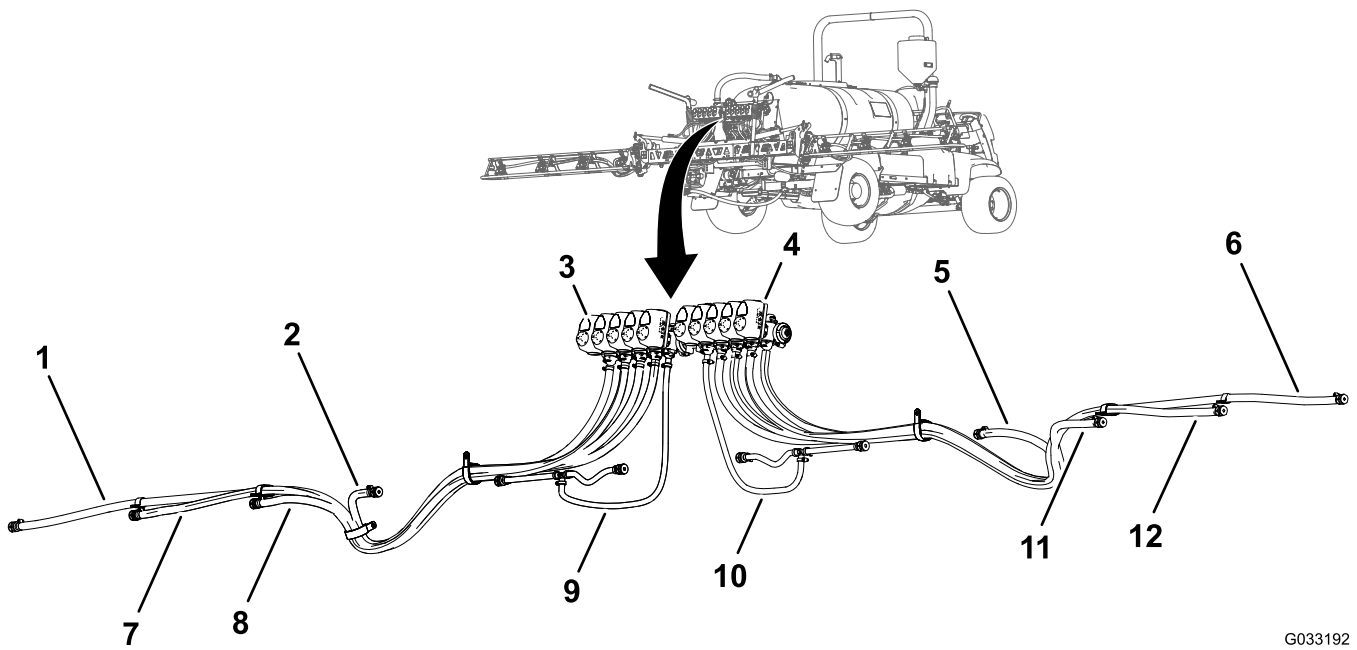

G033192  
g033192

**Figure 71**

- |   |  |  |
|---|--|--|
| 1. Supply hose 279 cm (110 inches)—sprayer nozzle 1 | 5. Supply hose 188 cm (74 inches)—sprayer nozzle 9   | 9. Supply hose 81 cm (32 inches)—sprayer nozzle 5 and 6  |
| 2. Supply hose 188 cm (74 inches)—sprayer nozzle 4  | 6. Supply hose 279 cm (110 inches)—sprayer nozzle 12 | 10. Supply hose 81 cm (32 inches)—sprayer nozzle 7 and 8 |
| 3. Nozzle valve 1                                   | 7. Supply hose 234 cm (92 inches)—sprayer nozzle 2   | 11. Supply hose 188 cm (74 inches)—sprayer nozzle 10     |
| 4. Nozzle valve 10                                  | 8. Supply hose 188 cm (74 inches)—sprayer nozzle 3   | 12. Supply hose 234 cm (92 inches)—sprayer nozzle 11     |

## Assembling the Hoses to Nozzle Valves 1 through 4

1. Assemble the straight barbed fitting of a supply hose 279 cm (110 inches) onto the coupler of nozzle valve 1 (Figure 72).

**Note:** Ensure that the barbed fitting is fully seated onto the coupler.

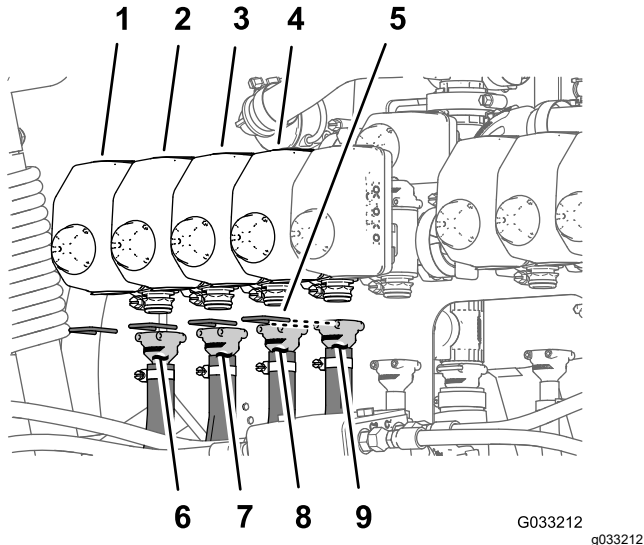

Figure 72

- |                   |                                    |
|-------------------|------------------------------------|
| 1. Nozzle valve 1 | 6. Supply hose 279 cm (110 inches) |
| 2. Nozzle valve 2 | 7. Supply hose 234 cm (92 inches)  |
| 3. Nozzle valve 3 | 8. Supply hose 188 cm (74 inches)  |
| 4. Nozzle valve 4 | 9. Supply hose 188 cm (74 inches)  |
| 5. Retainer       |                                    |

2. Secure the barbed fitting to the coupler with a retainer (Figure 72).
3. Assemble the straight barbed fitting of a supply hose 234 cm (92 inches) onto the coupler of nozzle valve 2 (Figure 72).

**Note:** Ensure that the barbed fitting is fully seated onto the coupler.

4. Secure the barbed fitting to the coupler with a retainer (Figure 72).
5. Assemble the straight barbed fitting of a supply hose 188 cm (74 inches) onto the coupler of nozzle valve 3 (Figure 72).

**Note:** Ensure that the barbed fitting is fully seated onto the coupler.

6. Secure the barbed fitting to the coupler with a retainer (Figure 72).

7. Assemble the straight barbed fitting of a supply hose 188 cm (74 inches) onto the coupler of nozzle valve 4 (Figure 72).

**Note:** Ensure that the barbed fitting is fully seated onto the coupler.

8. Secure the barbed fitting to the coupler with a retainer (Figure 72).

## Assembling the Hoses to Nozzle Valves 5 and 6

**Note:** Supply hose assembly 81 cm (32 inches) has a T-fitting with 2 branch hoses and 2 single barbed-hose shanks.

1. Assemble the straight barbed fitting of a supply hose 81 cm (32 inches) onto the coupler of nozzle valve 5 (Figure 73).

**Note:** Ensure that the barbed fitting is fully seated onto the coupler.

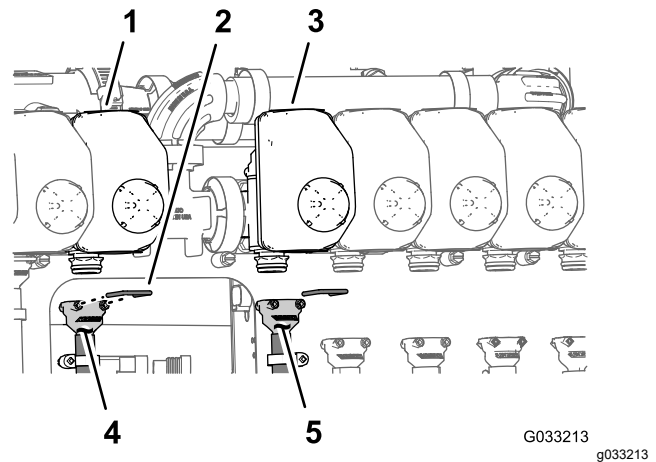

Figure 73

- |                   |                                  |
|-------------------|----------------------------------|
| 1. Nozzle valve 5 | 4. Supply hose 81 cm (32 inches) |
| 2. Retainer       | 5. Supply hose 81 cm (32 inches) |
| 3. Nozzle valve 6 |                                  |

2. Secure the barbed fitting to the coupler with a retainer (Figure 73).
3. Assemble the straight barbed fitting of a supply hose 81 cm (32 inches) onto the coupler of nozzle valve 6 (Figure 73).

**Note:** Ensure that the barbed fitting is fully seated onto the coupler.

4. Secure the barbed fitting to the coupler with a retainer (Figure 73).

## Assembling the Hoses to Nozzle Valves 7 through 10

1. Assemble the straight barbed fitting of a supply hose 188 cm (74 inches) onto the coupler of nozzle valve 7 (Figure 74).

**Note:** Ensure that the barbed fitting is fully seated onto the coupler.

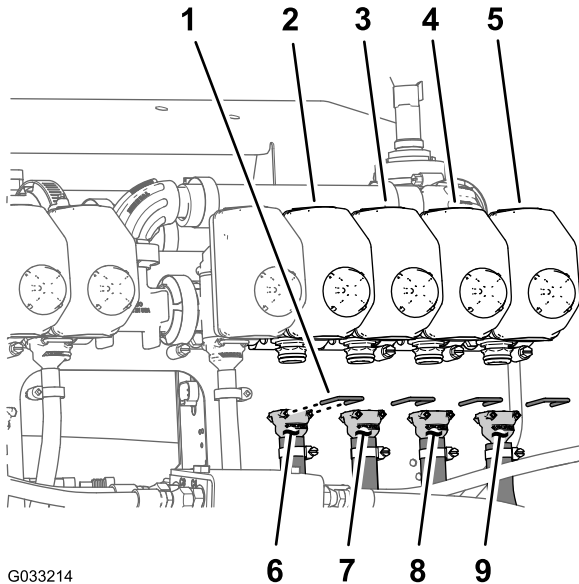

G033214

g033214

Figure 74

- |                    |                                    |
|--------------------|------------------------------------|
| 1. Retainer        | 6. Supply hose 188 cm (74 inches)  |
| 2. Nozzle valve 7  | 7. Supply hose 188 cm (74 inches)  |
| 3. Nozzle valve 8  | 8. Supply hose 234 cm (92 inches)  |
| 4. Nozzle valve 9  | 9. Supply hose 279 cm (110 inches) |
| 5. Nozzle valve 10 |                                    |

2. Secure the barbed fitting to the coupler with a retainer (Figure 74).
3. Assemble the straight barbed fitting of a supply hose 188 cm (74 inches) onto the coupler of nozzle valve 8 (Figure 74).

**Note:** Ensure that the barbed fitting is fully seated onto the coupler.

4. Secure the barbed fitting to the coupler with a retainer (Figure 74).
5. Assemble the straight barbed fitting of a supply hose 234 cm (92 inches) onto the coupler of nozzle valve 9 (Figure 74).

**Note:** Ensure that the barbed fitting is fully seated onto the coupler.

6. Secure the barbed fitting to the coupler with a retainer (Figure 74).

7. Assemble the straight barbed fitting of a supply hose 279 cm (110 inches) onto the coupler of nozzle valve 10 (Figure 74).

**Note:** Ensure that the barbed fitting is fully seated onto the coupler.

8. Secure the barbed fitting to the coupler with a retainer (Figure 74).

## Routing the Supply Hoses at the Outer-Boom Sections

1. Route the hoses for sprayer nozzles 1, 2, 3, and 4 through the R-clamp at the left outboard end of the center-boom section (Figure 75 and Figure 76).

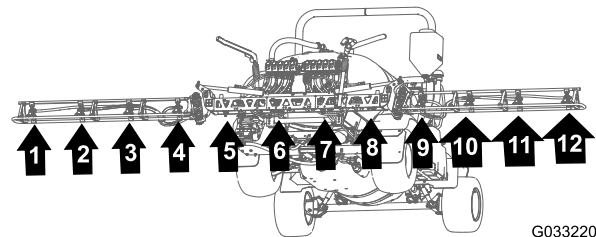

G033220

g033220

Figure 75

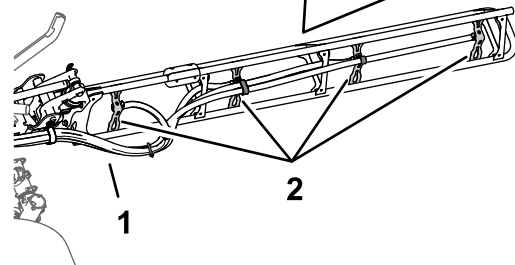
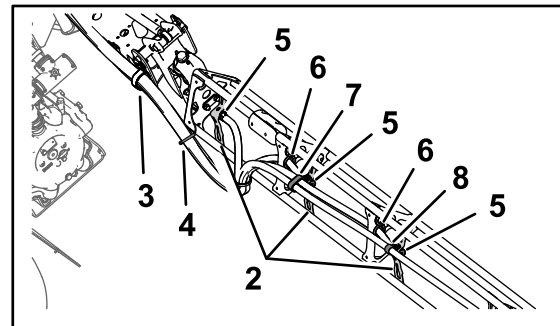

G033190

g033190

Figure 76

- |                    |  |
|--------------------|--|
| 1. Hoses           | 5. Single barbed-hose shank (1/2 inch) |
| 2. Nozzle supports | 6. Grommet                             |
| 3. R-clamp         | 7. Double R-clamp                      |
| 4. Cable tie       | 8. Single R-clamp                      |

2. Route the hoses for sprayer nozzles 7, 8, 9, and 10 through the R-clamp at the right outboard

end of the center-boom section (Figure 75 and Figure 76).

3. Route the supply hoses 279 cm (110 inches) and barbed-hose shanks (3/4 inch) along the boom section to sprayer nozzles 1 and 10 as shown in (Figure 75 and Figure 76).
4. Route the supply hoses 234 cm (92 inches) and barbed-hose shanks (3/4 inch) along the boom section to sprayer nozzles 2 and 9 along the boom section as shown in Figure 75 and Figure 76.
5. Route the supply hoses 188 cm (74 inches) and barbed-hose shanks (3/4 inch) along the boom section to sprayer nozzles 3 and 8 as shown in Figure 75 and Figure 76.

**Note:** Route the hoses through the lower rear grommets in the tube-frame brackets.

6. Route the supply hoses 188 cm (74 inches) and barbed-hose shanks (3/4 inch) along the boom section to sprayer nozzles 4 and 7 as shown in Figure 75 and Figure 76.

**Note:** Route the hoses through the lower rear grommets in the tube-frame brackets.

7. Bundle the 4 hoses for the sprayer nozzles together with a cable tie as shown in Figure 76.

## Installing the Sprayer Nozzles at the Outer-Boom Sections

1. Working with the sprayer nozzle that you removed in [12 Removing the Sprayer-Nozzle Hoses for the 3-Section System \(page 32\)](#), align the transfer tube in the saddle of a sprayer nozzle (Figure 77) with the hole in the side of the single barbed-hose shank (1/2 inch).

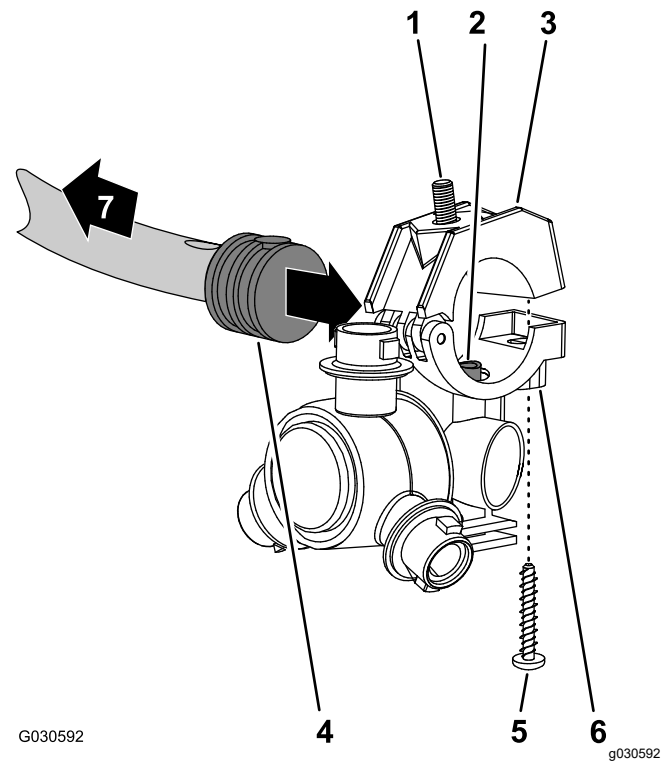

Figure 77

- |  |   |
|--|---|
| 1. Hex-head bolt (5/16 x 3/4 inch—stainless steel) | 5. Stainless steel screw (#12 x 1-1/4 inches) |
| 2. Transfer tube                                   | 6. Sprayer-nozzle body                        |
| 3. Upper clamp half                                | 7. Toward the boom section                    |
| 4. Single barbed-hose shank (1/2 inch)             |   |

2. Close the upper clamp half around the barbed-hose shank and secure the clamp half and spray-nozzle body (Figure 77) with the stainless steel screw (#12 x 1-1/4 inches); torque the stainless steel screw to 226 to 282 N·cm (20 to 25 in·lb).

**Note:** Ensure that the hex-head bolt (5/16 x 3/4 inch) is seated in the recess in the upper clamp half when closing the clamp.

3. Assemble the sprayer nozzles to the outer-boom section as follows:
  - At the nozzle positions 1 and 4, assemble the sprayer nozzle to the nozzle mount (A of Figure 78) with the flange locknut (5/16 inch) that you removed in step 2 of [12 Removing the Sprayer-Nozzle Hoses for the 3-Section System \(page 32\)](#).
  - At the nozzle positions 2 and 3, assemble the sprayer nozzle to the nozzle mount (A and B of Figure 78) with the flange locknut (5/16 inch) that you removed in step 2 of [12 Removing the Sprayer-Nozzle Hoses for the 3-Section System \(page 32\)](#).

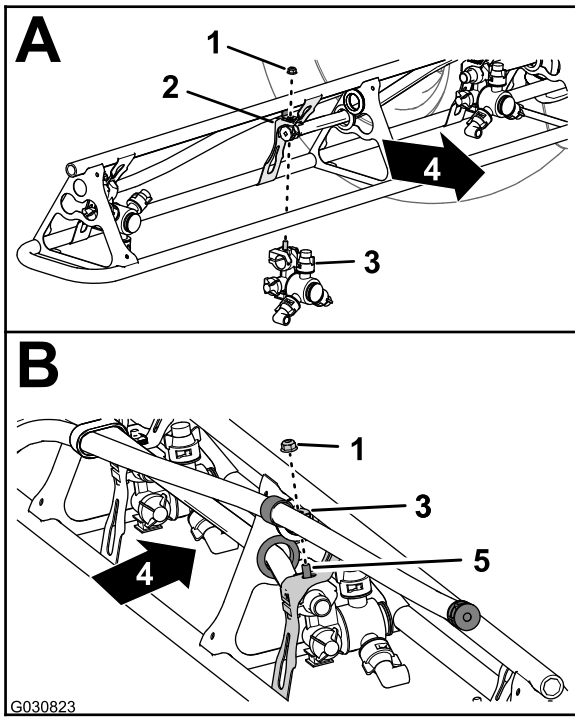

**Figure 78**

- |                               |  |
|-------------------------------|--|
| 1. Flange locknut (5/16 inch) | 4. Back of the machine                             |
| 2. Nozzle mount               | 5. Hex-head bolt (stainless steel—5/16 x 3/4 inch) |
| 3. Sprayer nozzle             |  |

4. Torque the flange locknut to 1,978 to 2,542 N·cm (175 to 225 in-lb).
5. Repeat steps 1 through 4 for the other sprayer nozzles for the boom section.
6. Repeat steps 1 through 5 to the outer-boom section at the other side of the machine.

## Routing the Supply Hoses at the Center-Boom Section

1. Ensure that the hoses and barbed couplers 13 x 810 mm (1/2 x 32 inches) are aligned to the front of the center-boom section between the left and right support brackets for the center section.
2. Route the hose 13 mm (10 inches) and barbed-hose shank between the truss braces of the outer truss (Figure 79).

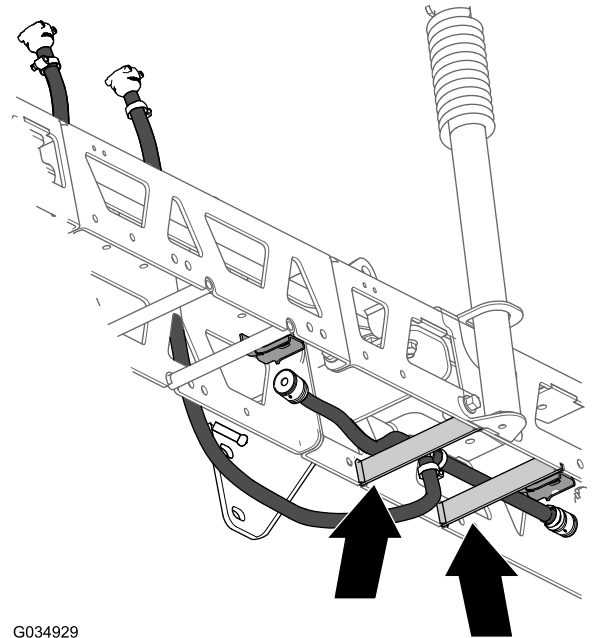
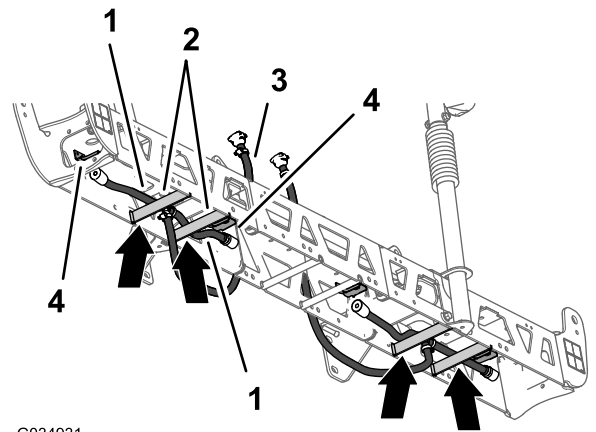

**Figure 79**

- |  |   |
|--|---|
| 1. Hoses 13 x 250 mm (1/2 x 10 inches) | 3. Hose and barbed-hose shank 13 x 810 mm (1/2 x 32 inches) |
| 2. Truss braces (left truss)           | 4. Sprayer-nozzle mounts                                    |

3. Route the hose and barbed-hose shank above the truss brace and outward to the outboard nozzle mount (Figure 79).
4. Route the other hose 13 mm (10 inches) and barbed-hose shank between the truss braces of the inner truss (Figure 79).
5. Route the hose and barbed-hose shank above the truss brace and inward to the inboard nozzle mount (Figure 79).
6. Repeat steps 2 through 7 for the other hose and nozzle assembly at the other outer truss (Figure 79 and Figure 82).
7. Route the hose and barbed coupler 13 x 810 mm (1/2 x 32 inches) to the side of the center-boom

section with the left and right support brackets for the boom section (Figure 79).

## Assembling the Sprayer Nozzles and Hoses for the Center-Boom Section

- Working with the sprayer nozzles that you removed in [12 Removing the Sprayer-Nozzle Hoses for the 3-Section System](#) (page 32), remove the stainless steel screws that secure the upper clamp halves to the saddles (Figure 80).

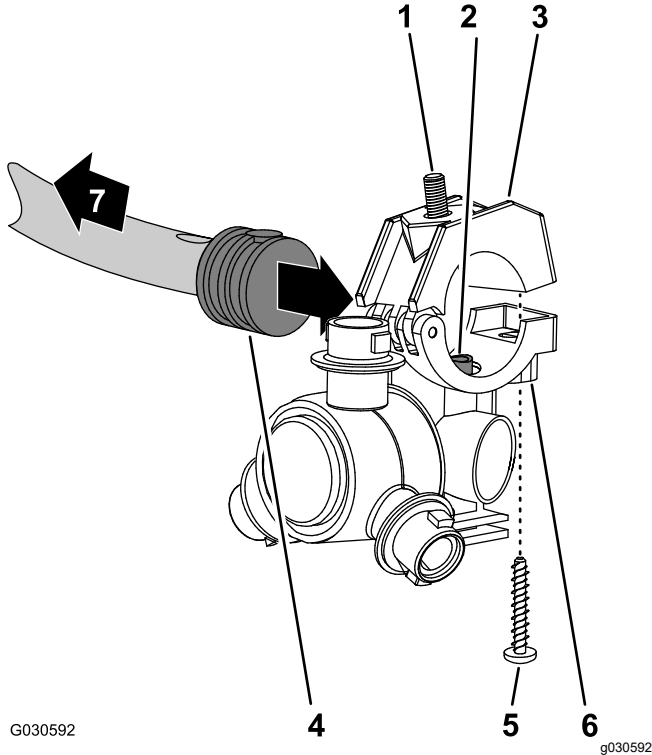

Figure 80

- Hex-head bolt (5/16 x 3/4 inch—stainless steel)
- Transfer tube
- Upper clamp half
- Single barbed-hose shank (1/2 inch)
- Stainless steel screw (#12 x 1-1/4 inches)
- Sprayer-nozzle body
- Toward the boom section

- Locate the hole in the side of single barbed-hose shank at the end of the hose 25 cm (10 inches) of the hose assembly (sprayer valve 5 or 6) for the center-boom section (Figure 80 and Figure 81).

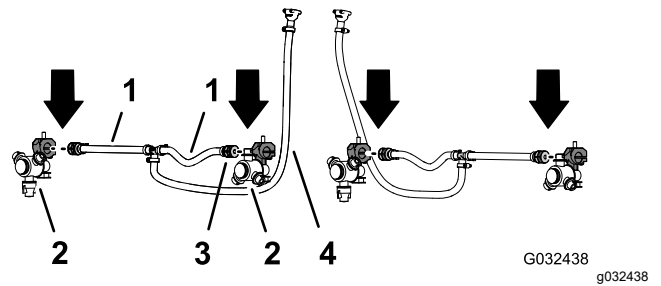

Figure 81

- Hose 13 x 250 mm (1/2 x 10 inches—sprayer valve 5 or 6)
- Sprayer nozzle
- Single barbed-hose shank 13 mm (1/2 inch)
- Hose and barbed coupler 13 x 810 mm (1/2 x 32 inches—sprayer valve 5 or 6)

- Align the transfer tube in the saddle of a sprayer nozzle (Figure 80) with the hole in the side of the single barbed-hose shank (1/2 inch).
- Close the upper clamp half around the barbed-hose shank and spray-nozzle body (Figure 80) with the stainless steel screw (#12 x 1-1/4 inches); torque the stainless steel screw to 226 to 282 N·cm (20 to 25 in-lb).

**Important:** Do not tighten the stainless steel screw more than the torque specification in step 4.

**Note:** Ensure that the hex-head bolt (5/16 x 3/4 inch) is seated in the recess in the upper clamp half when closing the clamp.

- Repeat steps 2 through 4 to the single barbed-hose shanks of the other hose assemblies (sprayer valve 5 or 6) for the center-boom section (Figure 80 and Figure 81).

## Installing the Sprayer Nozzles at the Center-Boom Sections

- Align the hex-head bolt (5/16 x 3/4 inch) of the sprayer nozzle through the hole in the nozzle mount (Figure 82) and loosely secure the nozzle to the mount with a flange locknut (5/16 inch) that you removed in steps 1 or 4 of 12 Removing the Sprayer-Nozzle Hoses for the 3-Section System (page 32).

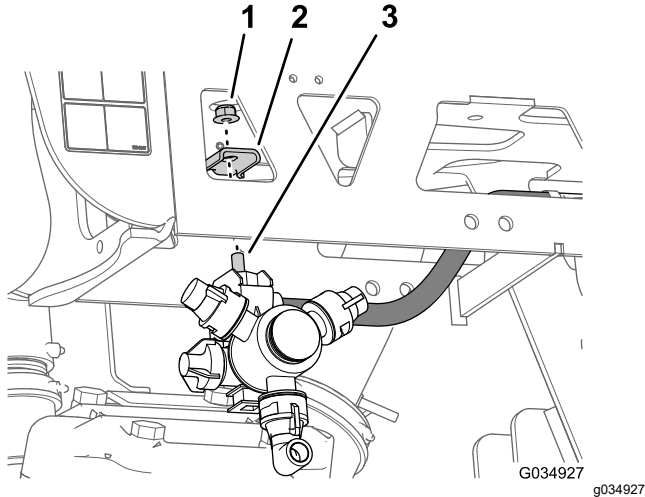

Figure 82

- Flange locknut (5/16 inch)
  - Nozzle mount (outboard)
  - Hex-head bolt (5/16 x 3/4 inch—stainless steel)
- 
- Repeat step 1 for the 3 other sprayer nozzles for the center-boom section.
  - Torque the flange locknuts to 1978 to 2542 N-cm (175 to 225 in-lb).

# 14

## Assembling the Rear Wiring Harness to the Machine

Parts needed for this procedure:

1	Rear wire harness
3	Cable tie

### Routing Wire Harness Along the Frame Tube

- Locate the 165 cm (65 inch) branch and the 203 cm (80 inch) branch of the new electrical harness (Figure 83).

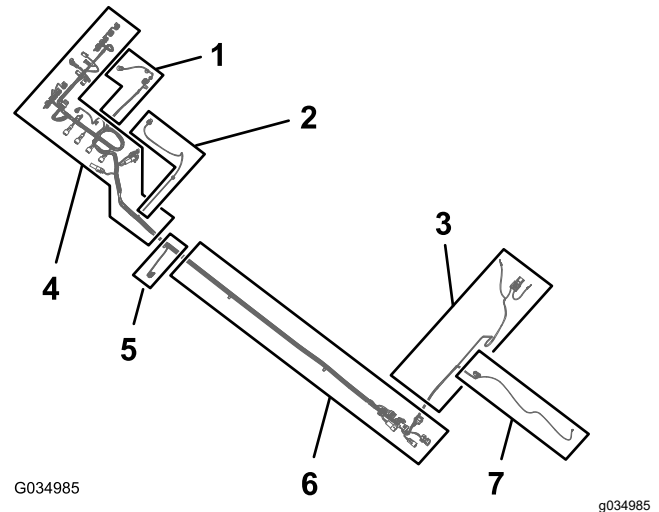

Figure 83

- 81 cm (32 inch) wire-harness branch—**flow meter and agitation valve**
- 86 cm (34 inch) wire-harness branch—**spray-pump solenoid**
- 165 cm (65 inch) wire-harness branch—ring terminals and fuse (unmarked)
- 203 cm (80 inch) wire-harness branch—**ASC10**, lift cylinder solenoids, **nozzle-valves** 1 through 10
- 33 cm (13 inch) wire-harness branch—speed sensor
- 170 cm (67 inch) wire-harness branch—front harness interface connectors
- 81 cm (32 inch) wire-harness branch—sprayer pump shutoff circuit

- 
- Route the 165 cm (65 inch) branch and the 203 cm (80 inch) branch of the new electrical

harness between the valve mount for the 10 sprayer valves and right support for the manifold mount (Figure 84).

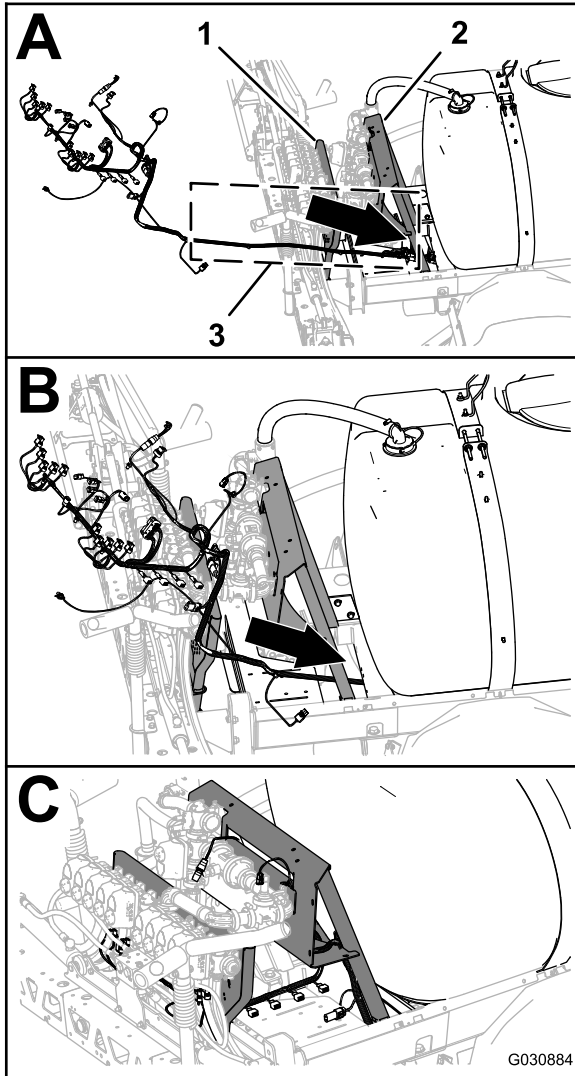

Figure 84

1. Valve mount (10 sprayer valves)
2. Manifold mount
3. 165 cm (65 inch) and 203 cm (80 inch) branches (electrical harness)

3. Route the 165 cm (65 inch) branch and the 203 cm (80 inch) branch of the electrical harness forward along the right frame tube (Figure 85).

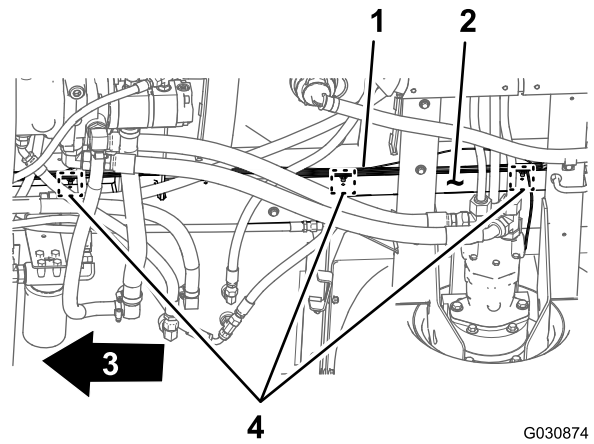

Figure 85

1. Rear wire harness—203 cm (80 inch) branch
2. Right frame tube
3. Front of the machine
4. Push-in fasteners and cable tie locations

4. Insert the push-in fasteners of the 203 cm (80 inch) branch of the rear wire harness into the holes in the right frame tube (Figure 85) where the push-in fasteners of the old rear harness were removed; refer to step 3 in [Disconnecting the Front and Rear Wire Harnesses](#) (page 14).

## Connecting the Front and Rear Wire Harnesses

**Note:** Use a machine hoist when connecting the front and rear wire harnesses.

1. From under the machine along the right frame tube, locate the electrical connectors for the front and rear wire harnesses of the machine (Figure 86).

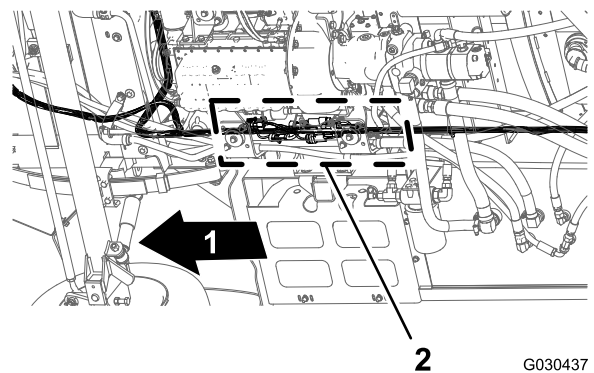
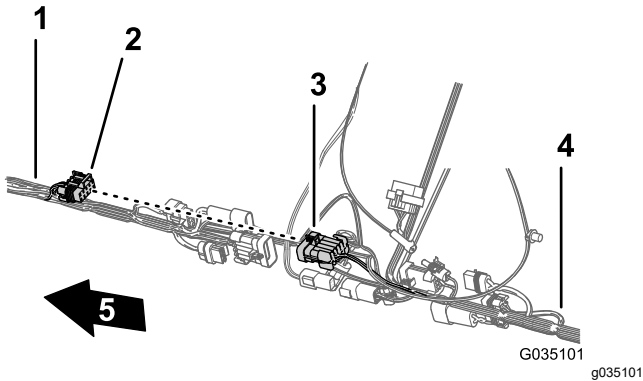

Figure 86

1. Front of the machine
2. Connector interfaces (front and rear wire harnesses)

2. Connect the 10-socket connector of the front harness for the sprayer-harness interconnect

into the 10-pin connector of the rear harness for the sprayer-harness interconnect (Figure 87).



**Figure 87**

- |  |                         |
|--|-------------------------|
| 1. Front wire harness  | 4. Rear wire harness    |
| 2. 10-pin connector—sprayer-harness interconnect (front harness) | 5. Front of the machine |
| 3. 10-pin connector—sprayer-harness interconnect (rear harness)  |                         |

3. Connect the 8-pin connector of the front harness for the sprayer-harness interconnect into the 8-socket connector of the rear harness for the rate switch (Figure 88).

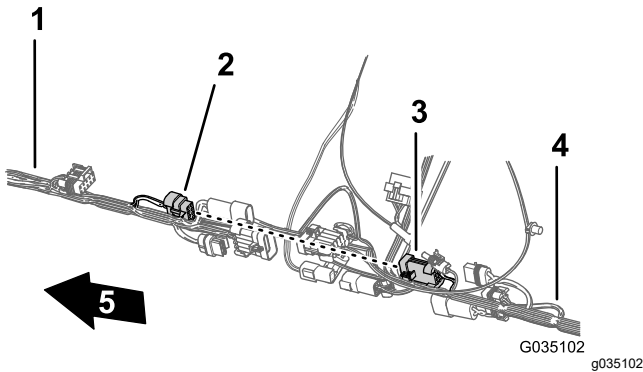

**Figure 88**

- |   |                         |
|---|-------------------------|
| 1. Front wire harness   | 4. Rear wire harness    |
| 2. 8-pin connector—sprayer-harness interconnect (front harness) | 5. Front of the machine |
| 3. 8-socket connector—rate switch (rear harness)                |                         |

4. Connect the 2-pin connector of the front harness for the rinse pump into the 2-socket connector of the rear harness for the rinse pump (Figure 89).

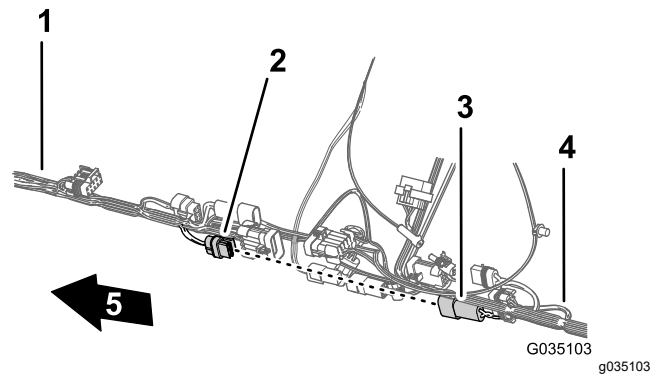

**Figure 89**

- |   |                         |
|---|-------------------------|
| 1. Front wire harness                           | 4. Rear wire harness    |
| 2. 2-socket connector—rinse pump (rear harness) | 5. Front of the machine |
| 3. 2-pin connector—rinse pump (front harness)   |                         |

5. Connect the 2-pin connector of the front harness for the hose-reel power into the 2-socket connector of the rear harness for the hose-reel power (Figure 90).

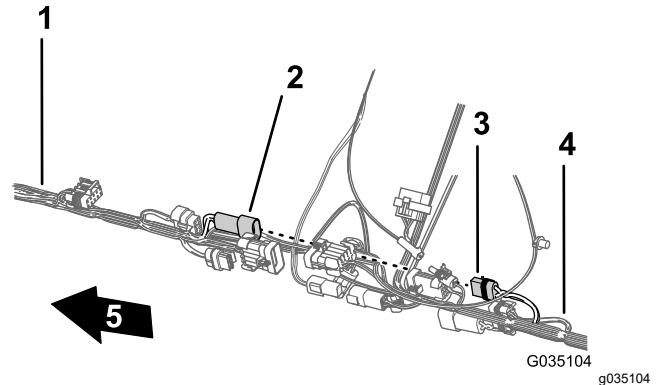

**Figure 90**

- |  |                         |
|--|-------------------------|
| 1. Front wire harness                          | 4. Rear wire harness    |
| 2. 2-pin connector—hose reel (front harness)   | 5. Front of the machine |
| 3. 2-socket connector—hose reel (rear harness) |                         |

6. Connect the 10-pin connector of the front harness for the sprayer-harness interconnect into the 10-socket connector of the rear harness for the sprayer-harness interconnect (Figure 91).

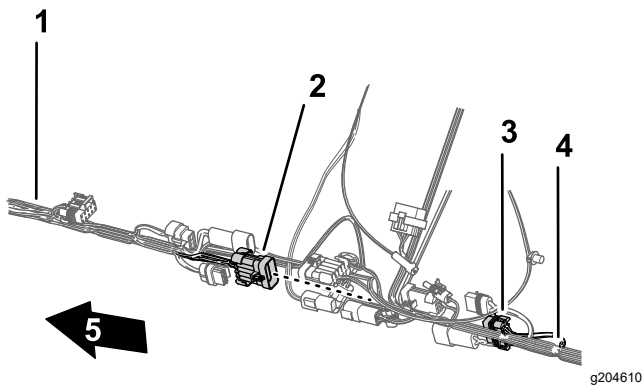

**Figure 91**

- |  |                         |
|--|-------------------------|
| 1. Front wire harness  | 4. Rear wire harness    |
| 2. 10-pin connector—sprayer-harness interconnect (front harness)   | 5. Front of the machine |
| 3. 10-socket connector—sprayer-harness interconnect (rear harness) |                         |

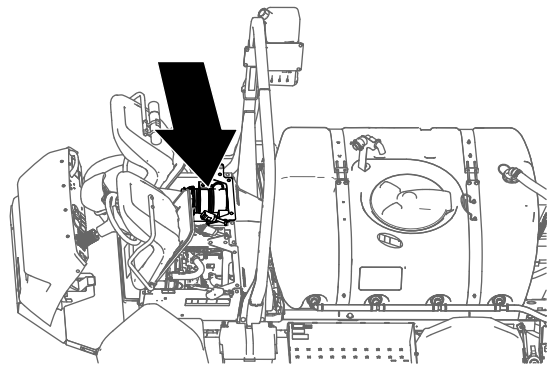

g191268

7. To ease connecting the navigation-electrical and data harnesses, ensure that the 1-socket connector of the rear-wire harness and the 4-socket connector of the rear-wire harness aligns to the top of the harness (Figure 92).

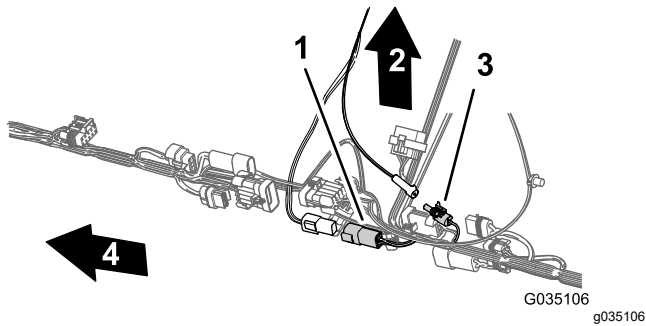

**Figure 92**

- |   |   |
|---|---|
| 1. 4-socket connector (rear-wire harness) | 3. 1-socket connector (rear-wire harness) |
| 2. Top of the machine                     | 4. Front of the machine                   |

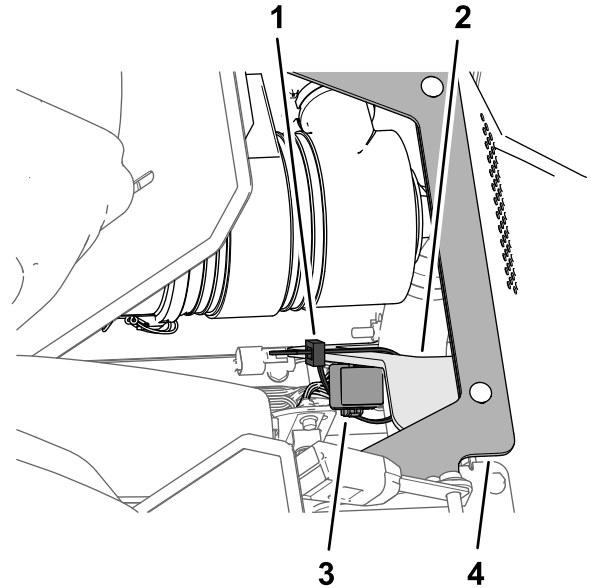

**Figure 93**

- |                  |                         |
|------------------|-------------------------|
| 1. Cable tie     | 3. Pump-interrupt relay |
| 2. Right support | 4. Seat-support angle   |

8. Secure the pump-interrupt relay of the rear-wire harness to the right support for the seat-support angle (Figure 93).

## Routing the Pressure-Sense Tube for the Dash Gauge along the Rear Wire Harness

1. Route the pressure-sense tube for the dash gauge along the rear wire harness of the machine (Figure 94).

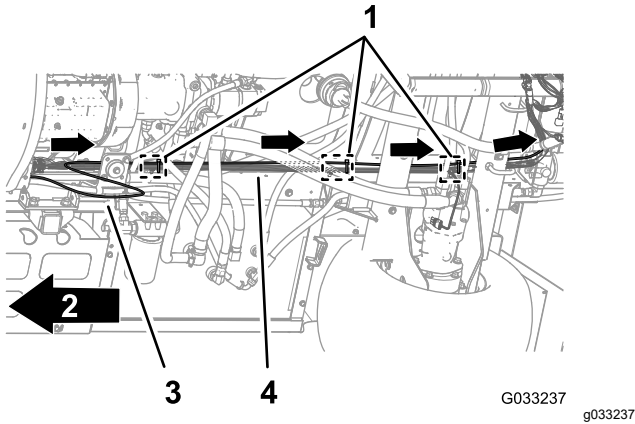

Figure 94

- |   |                        |
|---|------------------------|
| 1. Cable ties (3 push-in fasteners—chassis anchor points) | 3. Pressure-sense tube |
| 2. Front of the machine                                   | 4. Rear wire harness   |

2. Secure the pressure-sense tube to the rear wire harness with 3 cable ties adjacent to the 3 push-in fasteners at the chassis anchor points for the rear wire harness (Figure 94).

**Important:** Do not pinch or collapse the pressure-sense tube; tighten the cable ties only enough to support the tube.

# 15

## Installing the Engine-Control Module and Mounting Bracket (Machine Models with a Gasoline Engine)

No Parts Required

### Procedure

1. Align the holes in the mounting bracket for the engine-control module with the hole in the support bracket of the engine and accessory case of the engine (Figure 95).

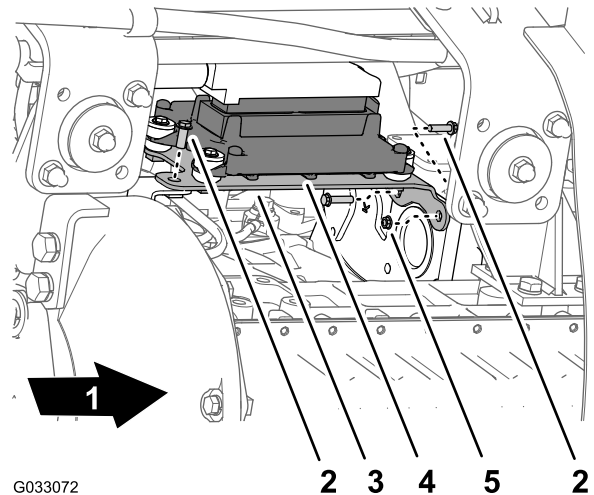
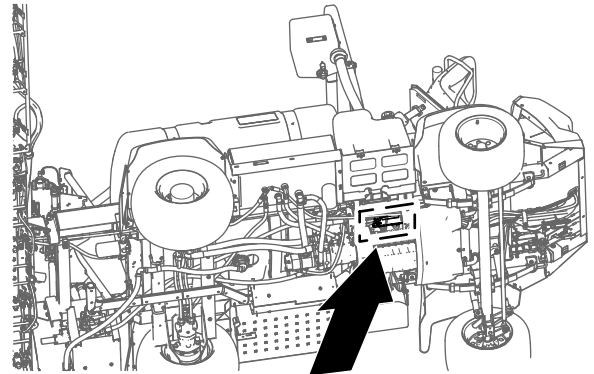

Figure 95

- |                         |                          |
|-------------------------|--------------------------|
| 1. Front of the machine | 4. Engine-control module |
| 2. Flange-head bolt     | 5. Flange nut            |
| 3. Mounting bracket     |                          |

- Assemble the mounting bracket to the engine with the 3 flange head bolts and 1 flange nut that you removed in step 1 of 5 [Removing the Engine-Control Module and Mounting Bracket \(Machine Models with a Gasoline Engine\)](#) (page 12); tighten the bolts and nuts by hand.

- Assemble the undercarriage shroud to the engine-mount brackets and bolts ([Figure 96](#)) with the 4 flange locknuts (5/16 inch) that you removed in step 2 of 4 [Removing the Undercarriage Shroud](#) (page 11).
- Align the holes in the rear part of the undercarriage shroud with the holes in the chassis ([Figure 97](#)).

# 16

## Installing the Undercarriage Shroud

No Parts Required

### Procedure

- Align the undercarriage shroud to the bottom chassis of the machine ([Figure 96](#)).

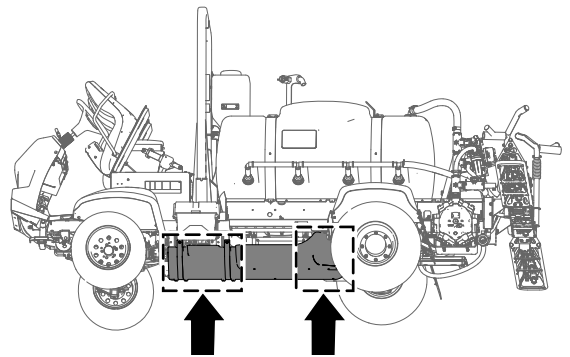

g189584

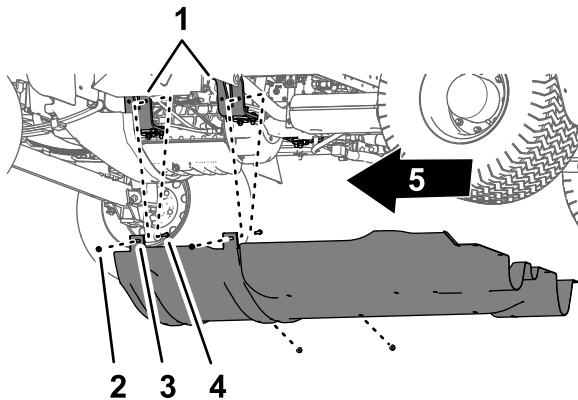

g189583

**Figure 96**

- |                           |                                |
|---------------------------|--------------------------------|
| 1. Engine mounts          | 4. Flange locknuts (5/16 inch) |
| 2. Bolt—shown for clarity | 5. Front of the machine        |
| 3. Undercarriage shroud   |                                |

- Slip the forward mounting flanges of the undercarriage shroud over the bolts and carriage bolt at the engine-mount brackets of the machine ([Figure 96](#)).

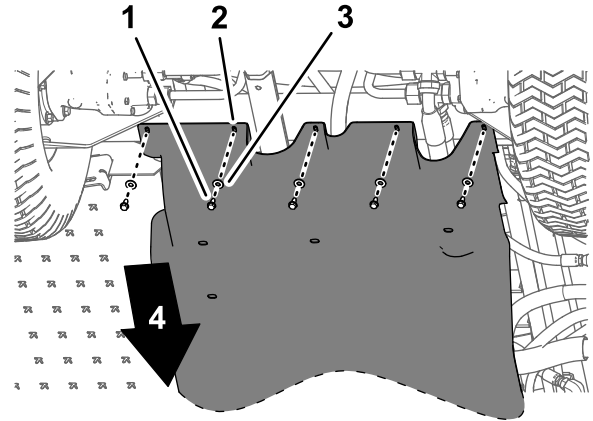

g189585

**Figure 97**

2017 machine shown; 2016 machines are similar

- |  |                         |
|--|-------------------------|
| 1. Flange-head bolts (5/16 x 7/8 inch) | 3. Washers (5/16 inch)  |
| 2. Undercarriage shroud                | 4. Front of the machine |

- Assemble the rear part of the undercarriage shroud to the chassis ([Figure 97](#)) with the hardware that you removed in step 1 of 4 [Removing the Undercarriage Shroud](#) (page 11) as follows:
  - 2016 machines**—7 flange-head bolts (5/16 x 7/8 inch) and 7 washers (5/16 inch)
  - 2017 and later machines**—5 flange-head bolts (5/16 x 7/8 inch) and 5 washers (5/16 inch)
- Torque the nuts and bolts to 1129 to 1582 N·cm (100 to 140 in·lb).

# 17

## Connecting the Rear Wire Harness

Parts needed for this procedure:

3	Cable tie
---	-----------

### Routing the Wire Harness at the Manifold Mount

1. Route the 203 cm (80 inch) branch of the wire harness inboard of the support strut for the valve mount and rearward toward the 10-valve mount as shown in [Figure 98](#).

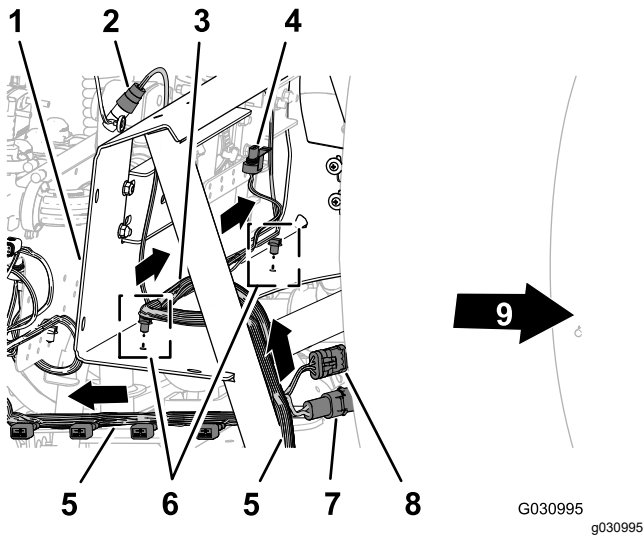

Figure 98

- |  |                                      |
|--|--------------------------------------|
| 1. Manifold mount  | 6. Push-in fasteners                 |
| 2. 3-socket connector (flow meter)   | 7. 2-pin connector (hose-reel power) |
| 3. 81 cm (32 inch) wire-harness branch—flow meter and agitation valve                              | 8. 3-socket connector (hose reel)    |
| 4. Electrical connector (Agitation valve)  | 9. Front of the machine              |
| 5. 203 cm (80 inch) wire-harness branch—ASC10, lift cylinder solenoids, nozzle-valves 1 through 10 |                                      |

2. Route the 81 cm (32 inch) wire-harness branch for the flow meter and agitation valve across the front of the manifold mount ([Figure 98](#)).

3. Insert the push-in fasteners of the 81 cm (32 inch) wire-harness branch into the holes in the lower flange of the manifold mount ([Figure 98](#)).

### Routing the Wire Harness at the 10-Valve Mount

1. Route the 203 cm (80 inch) wire-harness branch across the back of the 10-valve mount with the 10 connectors for the nozzle valves rearward and below the valves ([Figure 99](#)).

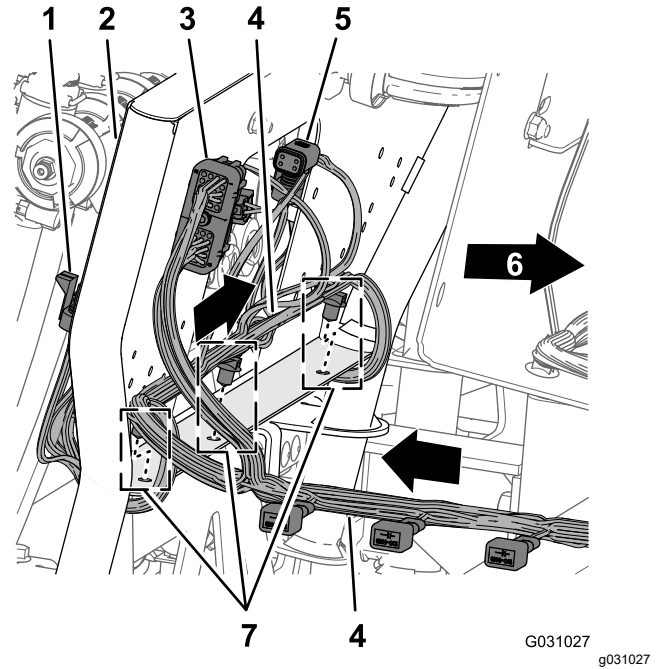

Figure 99

- |  |                                       |
|--|---------------------------------------|
| 1. 3-socket connector (nozzle-valve position 10)   | 5. 4-socket connector (to the ASC 10) |
| 2. 10-valve mount  | 6. Front of the machine               |
| 3. 40-socket connector (ASC 10)  | 7. Push-in fasteners                  |
| 4. 203 cm (80 inch) wire-harness branch—ASC10, lift cylinder solenoids, nozzle-valves 1 through 10 |                                       |

2. Insert the push-in fasteners of the 203 cm (80 inch) wire-harness branch into the holes in the lower flange of the 10-valve mount ([Figure 99](#)).

## Routing the Wire Harness for the Sprayer Pump

1. Route the 86 cm (34 inch) wire-harness branch for the spray-pump solenoid across the top of the sprayer frame channel and down toward the sprayer-pump solenoid ([Figure 100](#)).

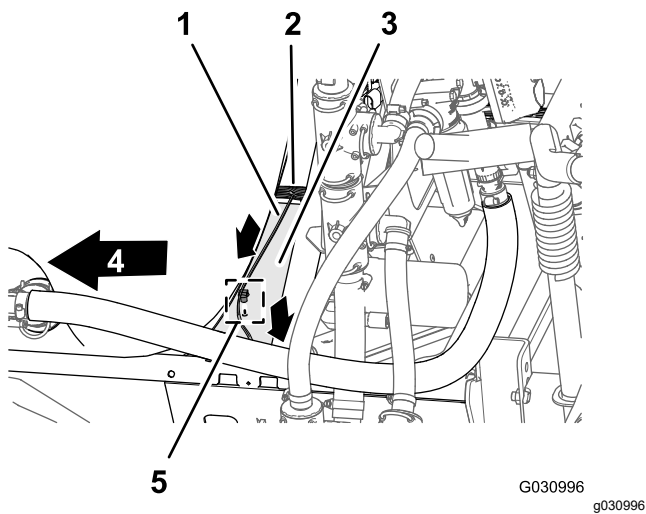

**Figure 100**

- |  |                         |
|--|-------------------------|
| 1. 86 cm (34 inch) wire-harness branch—spray-pump solenoid   | 4. Front of the machine |
| 2. 203 cm (80 inch) wire-harness branch—ASC10, lift cylinder solenoids, nozzle-valves 1 through 10 | 5. Push-in fastener     |
| 3. Channel (sprayer frame)   |                         |

2. Insert the push-in fastener of the 86 cm (34 inch) wire-harness branch into the hole in the sprayer frame channel ([Figure 100](#)).

## Connecting the Wire Harness to the Manifold Mount Components

1. Route the connectors of the 203 cm (80 inch) wire-harness branch labeled **Flow Meter** and labeled **Pressure Transducer** rearward of the manifold mount ([Figure 101](#)).

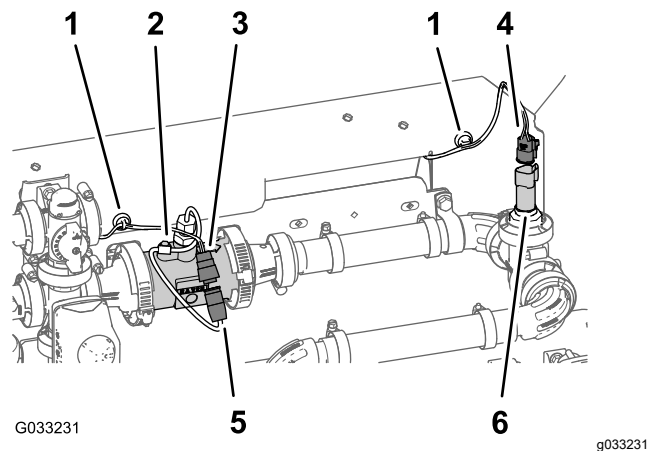

**Figure 101**

- |  |   |
|--|---|
| 1. Magnetic-harness anchor                                   | 4. 3-socket connector (rear wire harness—labeled Pressure Transducer) |
| 2. Flow meter  | 5. 3-pin connector (flow-meter harness)                               |
| 3. 3-socket connector (rear wire harness—labeled Flow Meter) | 6. 3-pin connector (pressure transducer)                              |

2. Connect the 3-socket connector of the 203 cm (80 inch) wire-harness branch for the flow meter (not labeled) into the 3-pin connector of the harness of the flow meter ([Figure 101](#)).
3. Connect the 3-socket connector of the 203 cm (80 inch) wire-harness branch for the labeled **Pressure Transducer** into the 3-pin connector of the pressure transducer ([Figure 101](#)).
4. Adhere the magnet-harness anchors for the flow meter and the pressure transducer onto the surface of the manifold mount ([Figure 101](#)).
5. Route the 3-pin connector for the harness of the agitation valve forward of the manifold mount ([Figure 102](#)).

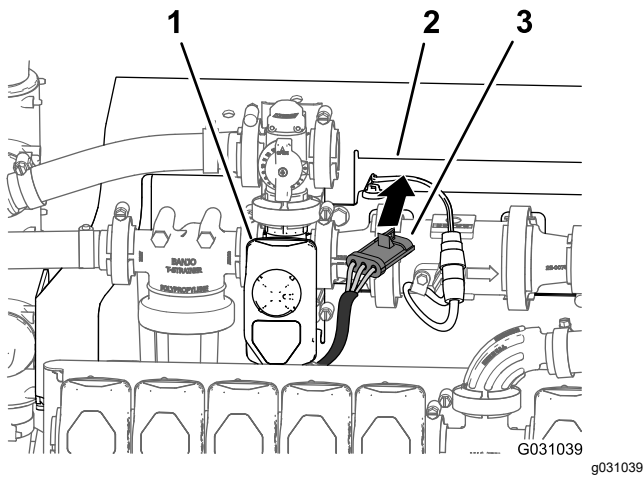

**Figure 102**

1. Agitation valve
2. Manifold mount
3. 3-socket connector (agitation-valve harness)

6. Connect the 3-pin connector for the harness of the agitation valve into the 3-socket connector of the 203 cm (80 inch) wire-harness branch labeled **Agitation Valve** (Figure 103).

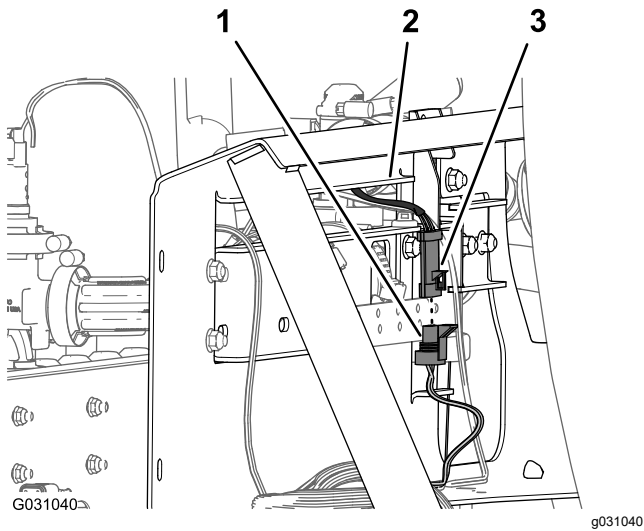
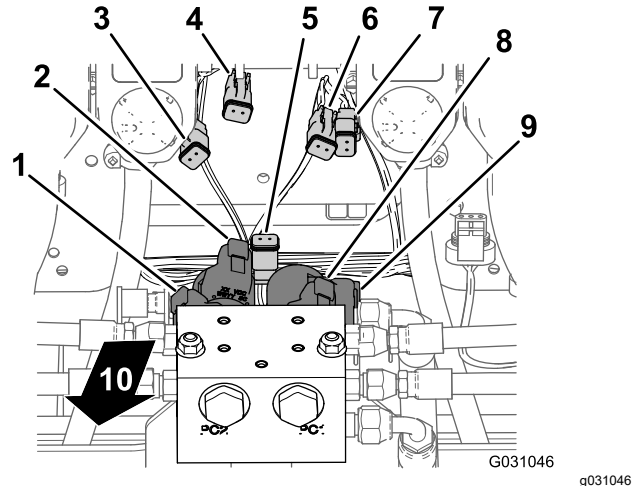

**Figure 103**

1. 3-pin connector (rear wire harness—labeled Agitation Valve)
2. Manifold mount
3. 3-socket connector (agitation-valve harness)

## Connecting the Wire Harness to the Solenoids for the Lift-Cylinder Manifold

1. At the bottom of the lift-cylinder manifold, connect the 2-socket connector of the rear wire harness labeled **Enable Solenoid** into the 2-pin connector for the enable solenoid (Figure 104 and Figure 105).



**Figure 104**

1. 2-pin connector—left down solenoid (lift-cylinder manifold)
2. 2-pin connector—left up solenoid (lift-cylinder manifold)
3. 2-socket connector—Left Down (main-harness connector)
4. 2-socket connector—Left Up (main-harness connector)
5. 2-socket connector—Enable Solenoid (main-harness connector)
6. 2-socket connector—Right Up (main-harness connector)
7. 2-socket connector—Right Up (main-harness connector)
8. 2-pin connector—right up solenoid (lift-cylinder manifold)
9. 2-pin connector—right down solenoid (lift-cylinder manifold)
10. Back of the machine

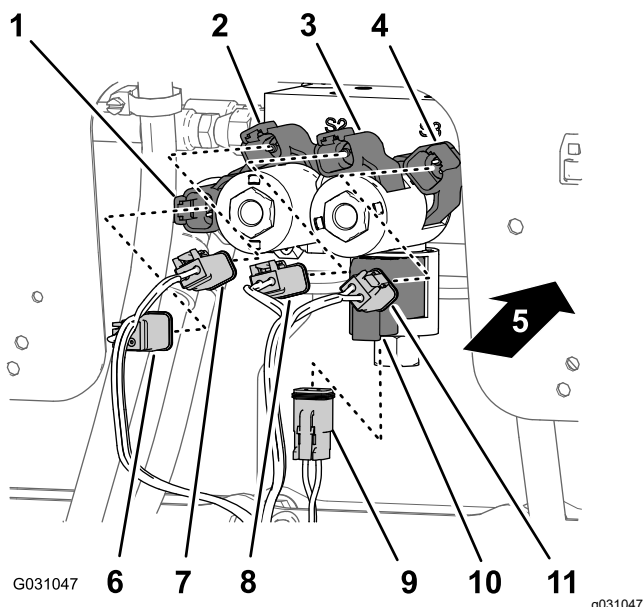

Figure 105

- |   |  |
|---|--|
| 1. 2-pin connector—right down solenoid (lift-cylinder manifold) | 7. 2-socket connector—Right Up (main-harness connector)        |
| 2. 2-pin connector—right up solenoid (lift-cylinder manifold)   | 8. 2-socket connector—Left Up (main-harness connector)         |
| 3. 2-pin connector—left up solenoid (lift-cylinder manifold)    | 9. 2-socket connector—Enable Solenoid (main-harness connector) |
| 4. 2-pin connector—left down solenoid (lift-cylinder manifold)  | 10. 2-pin connector—enable solenoid (lift-cylinder manifold)   |
| 5. Back of the machine  | 11. 2-socket connector—Left Down (main-harness connector)      |
| 6. 2-socket connector—Right Down (main-harness connector)       |  |

- At the lower right solenoid, connect the 2-socket connector of the rear wire harness labeled **Right Down** into the 2-pin connector for the right down solenoid (Figure 104 and Figure 105).
- At the upper right solenoid, connect the 2-socket connector of the rear wire harness labeled **Right Up** into the 2-pin connector for the right up solenoid (Figure 104 and Figure 105).
- At the lower left solenoid, connect the 2-socket connector of the rear wire harness labeled **Left Down** into the 2-pin connector for the left down solenoid (Figure 104 and Figure 105).
- At the upper left solenoid, connect the 2-socket connector of the rear wire harness labeled **Left Up** into the 2-pin connector for the left up solenoid.

## Connecting the Wire Harness to the Sprayer Valves

- Route the 3-socket connectors of the 203 cm (80 inch) wire-harness branch with labels **Nozzle Valve 1** through **Nozzle Valve 5** rearward of the 10-valve mount and below nozzle valves 1 through 5 (Figure 106).

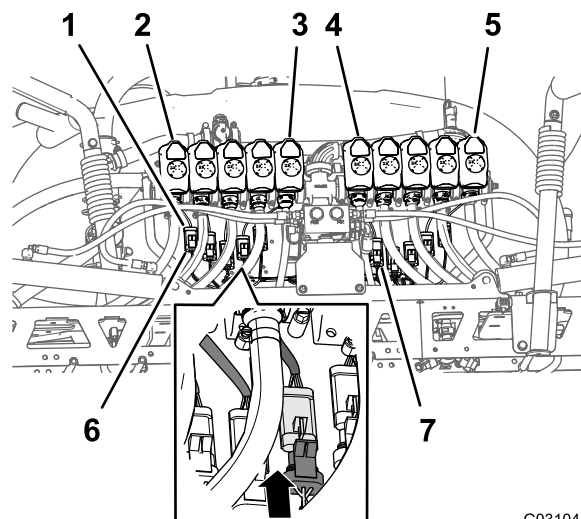

Figure 106

- |   |  |
|---|--|
| 1. 3-pin connector (nozzle-valve harness) | 5. Nozzle-valve 10   |
| 2. Nozzle-valve 1                         | 6. 3-pin socket connector (rear wire harness—labeled Nozzle 1) |
| 3. Nozzle-valve 5                         | 7. 3-pin socket connector (rear wire harness—labeled Nozzle 6) |
| 4. Nozzle-valve 6                         |  |

- Route the 3-socket connectors of the 203 cm (80 inch) wire-harness branch with labels **Nozzle Valve 6** through **Nozzle Valve 10** rearward of the 10-valve mount and below nozzle-valves 6 through 10 (Figure 106).
- Connect the 3-pin socket connector of the rear wire harness labeled **Nozzle 1** to the 3-pin connector of the harness for nozzle-valve 1 (Figure 106).

**Important:** It is important that you connect each labeled 3-pin socket connector of the rear wire harness to the correct 3-pin connector at each nozzle-valve position.

- Repeat step 3 at the nozzle-valve positions 2 through 10 (Figure 106).

## Connecting the Wire Harness to the Sprayer Pump and the Speed Sensor

1. At the back of the machine—inboard of the sprayer pump, connect the 2-socket connector labeled **Spray Pump Solenoid** of the 86 cm (34 inch) wire-harness branch into the 2-pin connector of the relay for the pump ([Figure 107](#)).

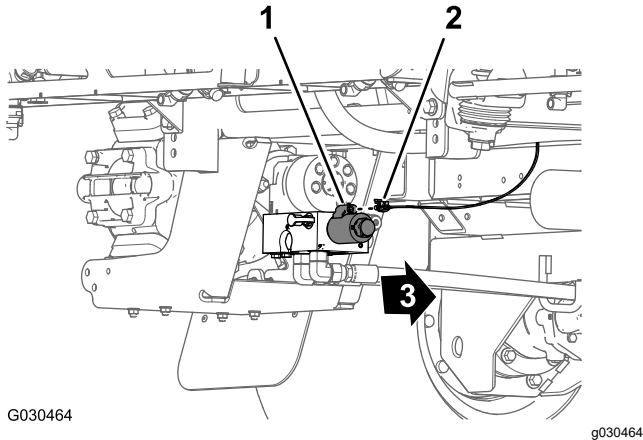

**Figure 107**

- |   |                         |
|---|-------------------------|
| 1. 2-pin connector (pump relay)                           | 3. Front of the machine |
| 2. 2-socket connector—86 cm (34 inch) wire-harness branch |                         |

2. At back of the machine (between the right frame tube and the right fender) connect the 3-pin connector of the speed-sensor harness at the right hydraulic-traction motor from the 3-socket connector (unmarked) of the rear, main harness ([Figure 108](#)).

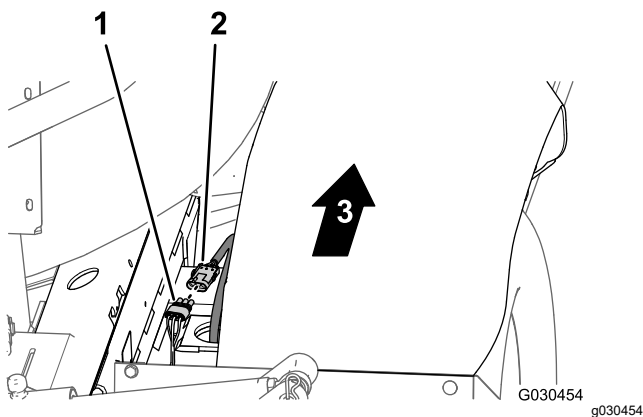

**Figure 108**

- |  |                         |
|--|-------------------------|
| 1. 3-socket connector (rear, main harness)   | 3. Front of the machine |
| 2. 3-pin connector (hydraulic-motor harness) |                         |

## Routing the Wire Harness through the Engine Compartment

1. Route the 165 cm (65 inch) branch of the wire harness up and into the rear part of the engine compartment, along the right support for the engine shroud—forward of the duct that connects the air filter and the engine ([Figure 109](#)).

**Note:** You will secure the 165 cm (65 inch) branch of the rear wire harness in [Routing the Navigation-Data and Electrical Harness to the Battery](#) (page 65).

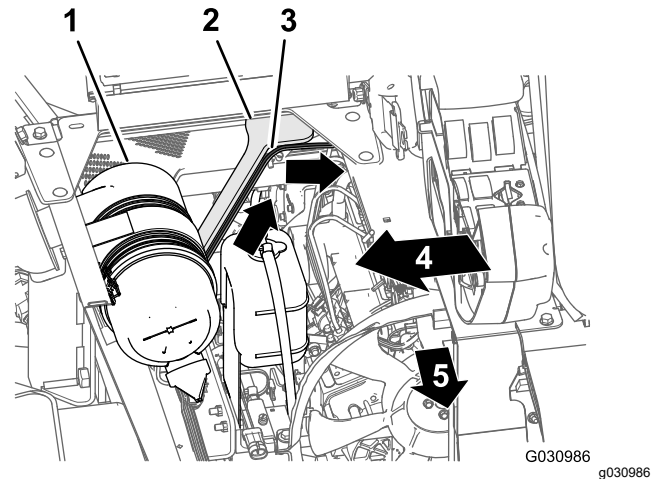
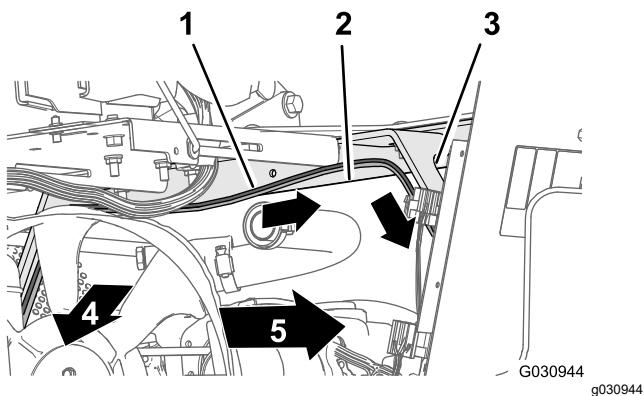

**Figure 109**

- |  |                                 |
|--|---------------------------------|
| 1. Air filter (engine)                         | 4. Right side of the machine    |
| 2. Engine-shroud support (right)               | 5. Front of the machine (right) |
| 3. 165 cm (65 inch) branch (rear wire harness) |                                 |

2. Route the 165 cm (65 inch) branch of the wire harness across the seat-box angle and down along the left support for the engine shroud ([Figure 110](#)).

**Note:** You will secure the 165 cm (65 inch) branch of the rear wire harness in [Routing the Navigation-Data and Electrical Harness to the Battery](#) (page 65).

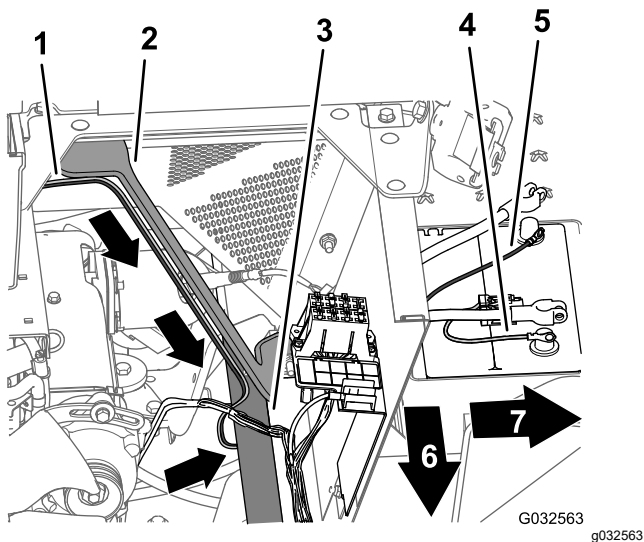

**Figure 110**

- |  |                             |
|--|-----------------------------|
| 1. 165 cm (65 inch) branch (rear wire harness) | 4. Front of the machine     |
| 2. Seat-box angle                              | 5. Left side of the machine |
| 3. Engine-shroud support (left)                |                             |

3. Route the 165 cm (65 inch) branch of the wire harness down along the left support for the engine shroud and under the left frame tube (Figure 111).

**Note:** You will secure the 165 cm (65 inch) branch of the rear wire harness in [Routing the Navigation-Data and Electrical Harness to the Battery](#) (page 65).



**Figure 111**

- |   |   |
|---|---|
| 1. 165 cm (65 inch) branch (rear wire harness)                              | 5. Negative terminal (black wire)—165 cm (65 inch) branch (rear wire harness) |
| 2. Engine-shroud support (left)   | 6. Front of the machine   |
| 3. Left frame tube  | 7. Left side of the machine   |
| 4. Positive terminal (red wire)—165 cm (65 inch) branch (rear wire harness) |   |

4. Route the 50 A fuse and the positive- and negative-ring terminals of the 165 cm (65 inch) branch of the wire harness to the top of the battery (Figure 111).

**Note:** You will complete the installation of the ring terminals in [Assembling the Rear GeoLink Harness, Navigation-Data and Electrical Harness, and Modem Power Harness to the Battery Cables](#) (page 81).

## Routing the Wire Harness for the Sprayer Pump Shutoff Circuit

1. Rotate the driver's seat forward and place the prop rod for the seat into the detent in the console channel.
2. Remove the 5 flange-head bolts (1/4 x 3/4 inch) that secure the cover at the left side of the center console (Figure 112).

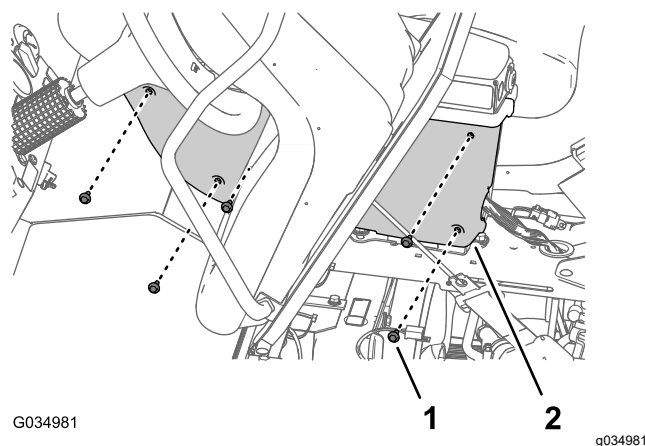

**Figure 112**

- |                                      |                                     |
|--------------------------------------|-------------------------------------|
| 1. Flange-head bolt (1/4 x 3/4 inch) | 2. Cover (left side—center console) |
|--------------------------------------|-------------------------------------|

3. Remove the cover from the center console (Figure 113).

**Note:** If needed, rotate the driver's seat down when removing the cover from the center console.

# Adding the Sprayer Pump Shutoff Circuit to the Sprayer-Pump Switch

1. Press in the latch for the 8-socket connector at the sprayer-pump switch, and separate the connector from the switch (Figure 115).

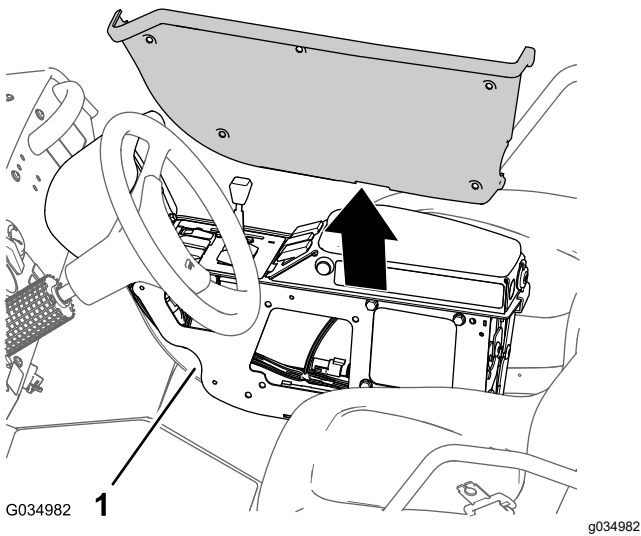

**Figure 113**

1. Console frame

4. Route the 81 cm (32 inch) branch of the rear-wire harness along the front wire harness and up through the grommet in the console channel (Figure 114).

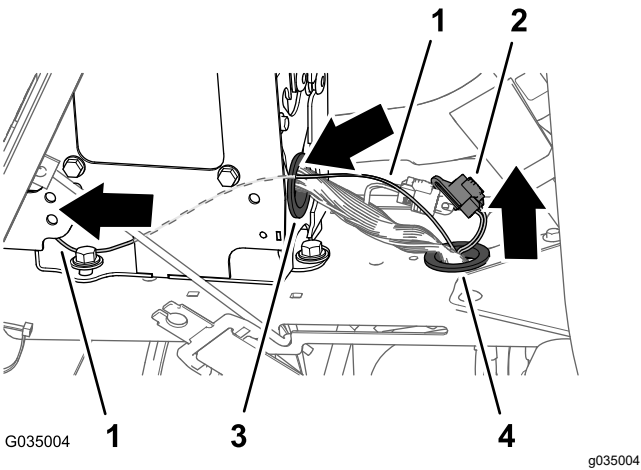

**Figure 114**

1. 81 cm (32 inch) wire-harness branch—sprayer pump shutoff circuit
2. 3-socket connector (CAN diagnostic)
3. Grommet (center console)
4. Grommet (console channel)

5. Route the 81 cm (32 inch) branch of the rear-wire harness forward along the front wire harness and through the grommet in the back of the center console (Figure 114).

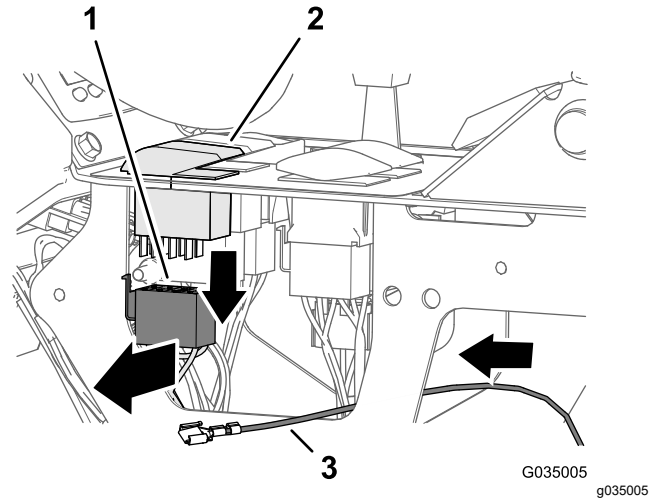

**Figure 115**

1. 8-socket connector (sprayer-pump switch)
2. Sprayer-pump switch
3. 81 cm (32 inch) wire-harness branch

2. Position the 8-socket connector so that you can see the back of the connector and the latch is up (Figure 116).

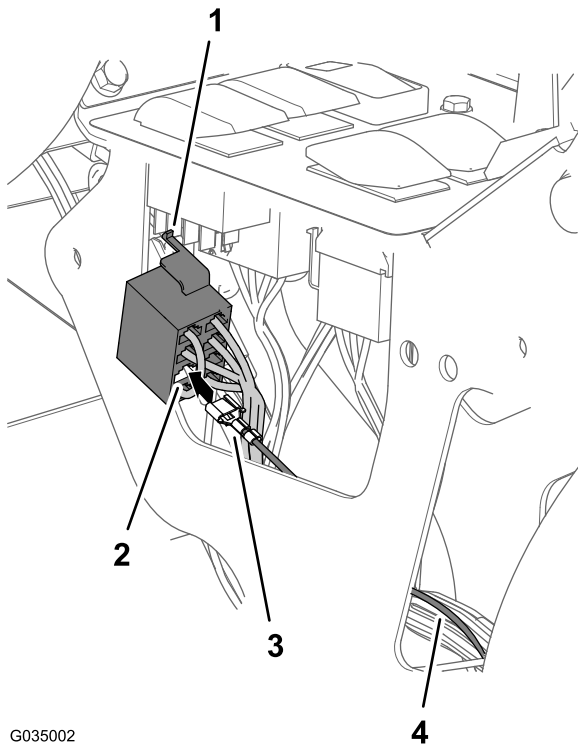

G035002

g035002

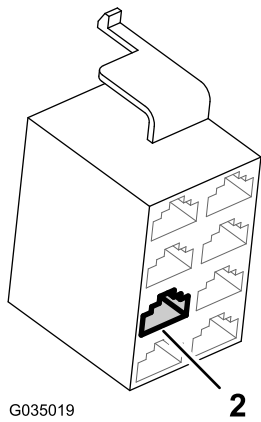

G035019

g035019

**Figure 116**

- |  |   |
|--|---|
| 1. Latch (8-socket connector)                                    | 3. Terminal (81 cm (32 inch) wire-harness branch) |
| 2. Terminal-position #4 (8-socket connector—sprayer-pump switch) | 4. 81 cm (32 inch) wire-harness branch            |

3. Insert the terminal at the end of the 81 cm (32 inch) branch of the rear-wire-harness into terminal position #4 of the 8-socket connector (Figure 116).

**Note:** Ensure that the latch of the terminal snaps securely into the 8-socket connector.

4. Connect the 8-socket connector if the wire harness with the 8-pin connector if the sprayer-pump switch (Figure 117).

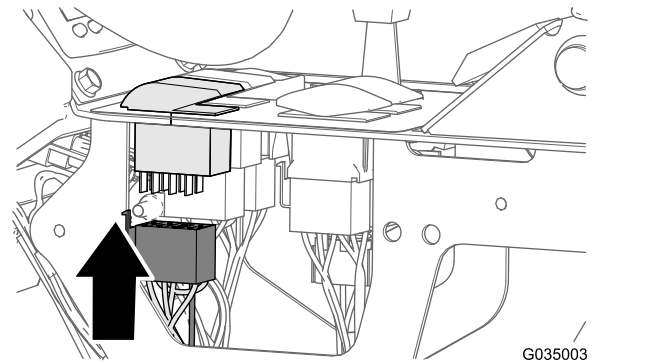

G035003  
g035003

**Figure 117**

5. Secure the 81 cm (32 inch) branch of the rear-wire-harness to the front wire harness of the machine as shown in Figure 117.

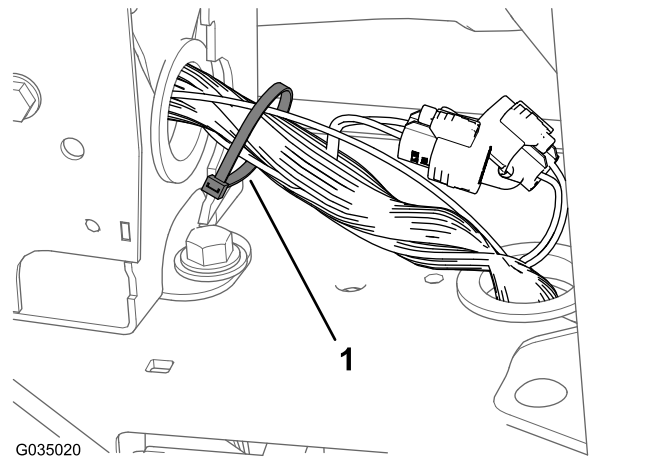

G035020

g035020

**Figure 118**

1. Cable tie

6. Align the cover that you removed in step 3 of [Routing the Wire Harness for the Sprayer Pump Shutoff Circuit \(page 52\)](#) to the left side of the center console (Figure 119).

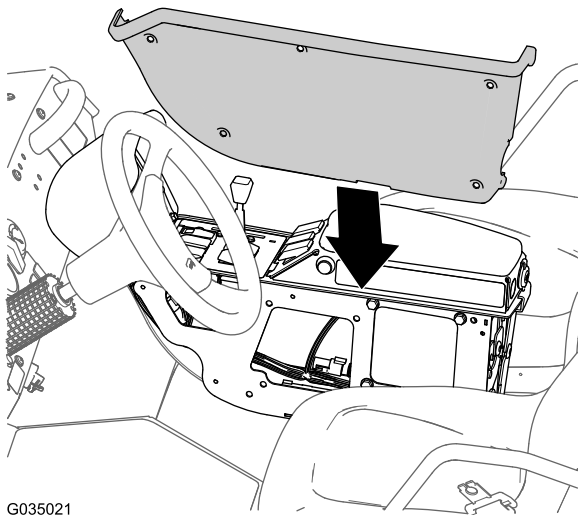

G035021

g035021

**Figure 119**

7. Assemble the cover to the center console with the 5 flange-head bolts (1/4 x 3/4 inch) that you removed in step 2 of [Routing the Wire Harness for the Sprayer Pump Shutoff Circuit \(page 52\)](#), and torque the bolts to 520 to 678 N·cm (46 to 60 in-lb).

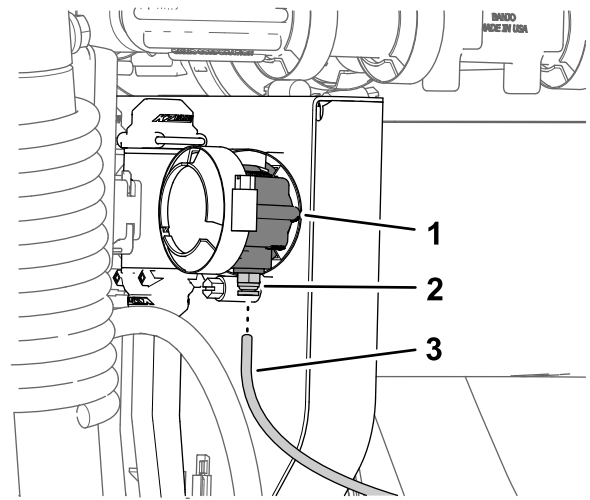

MADE IN USA

g189545

**Figure 120**

1. 90° elbow (nozzle valve 10)
2. Locking collar (tube coupler)
3. Pressure-sense tube (dash-pressure gauge)

2. Insert the sense tube into the locking collar until the tube is fully seated ([Figure 120](#)).

# 18

## Connecting the Pressure-Sense Tube for the Dash Gauge

No Parts Required

### Connecting the Pressure-Sense Tube for the Dash Gauge—Machines Without an Optional Hose Reel Kit

1. Align the end of the pressure-sense tube (plastic) for the pressure gauge in the dash with the locking collar for the tube coupler ([Figure 120](#)).

## Connecting the Pressure Sense-Tube—Optional Spray Gun Kit or Optional Pivoting Hose Reel Kit

1. Align the end of the pressure-sense tube (plastic) for the pressure gauge in the dash with the locking collar for the tube coupler ([Figure 121](#) and [Figure 122](#)).

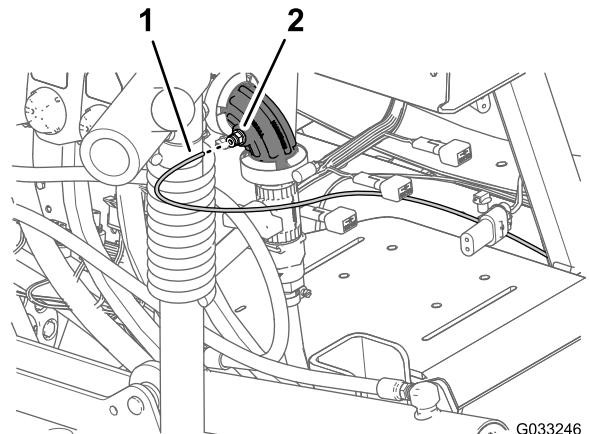

G033246

g033246

**Figure 121**

Optional Spray Gun Kit

1. Pressure-sense tube (dash gauge)
2. Tube coupler (90° elbow—nozzle valve 10)

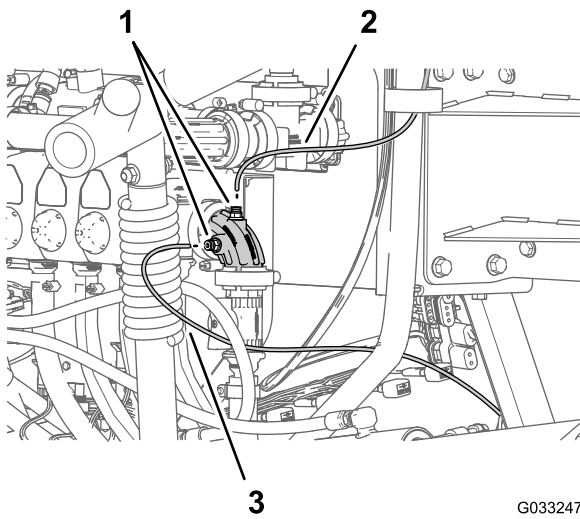

G033247  
g033247

**Figure 122**

**Optional Pivoting Hose Reel Kit**

- 1. Pressure-sense tube (pivoting-reel gauge)
- 2. Tube couplers (90° elbow—nozzle valve 10)
- 3. Pressure-sense tube (dash gauge)

- 2. Insert the sense tube into the locking collar until the tube is fully seated (Figure 121 and Figure 122).

# 19

## Installing the Navigation Receiver

**Parts needed for this procedure:**

1	Receiver mount
2	U-bolt
4	Flange locknut (3/8 inch)
1	Modem antenna bracket
3	Hex-head bolt (5 x 16 mm)
3	Washer (5 mm)
1	Navigation receiver—GeoLink precision spray system kit (Model 41633 or Model 41634)

### Assembling the Navigation Receiver Bracket to the Machine

- 1. Align the slot that is in the center of the receiver mount with the weld seam at the centerline of the ROPS tube (Figure 123).

**Note:** Ensure that the larger flange with 2 holes is rearward of the ROPS tube and the smaller flange with 1 hole is forward.

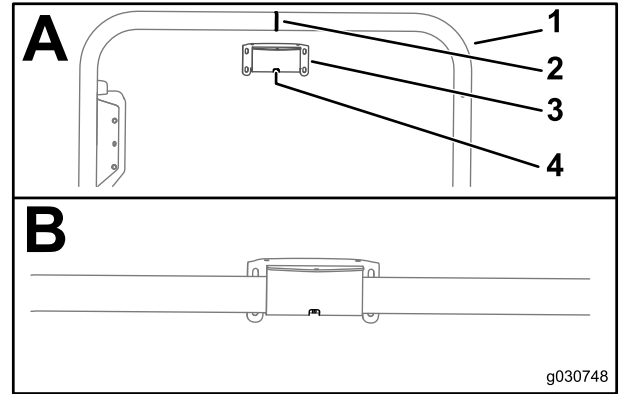

g030748

**Figure 123**

- 1. ROPS Tube
- 2. Weld seam (ROPS tube)
- 3. Receiver mount
- 4. Slot

- 2. Assemble the receiver mount to the ROPS tube (Figure 124) with the 2 U-bolts and 4 flange locknuts (3/8 inch).

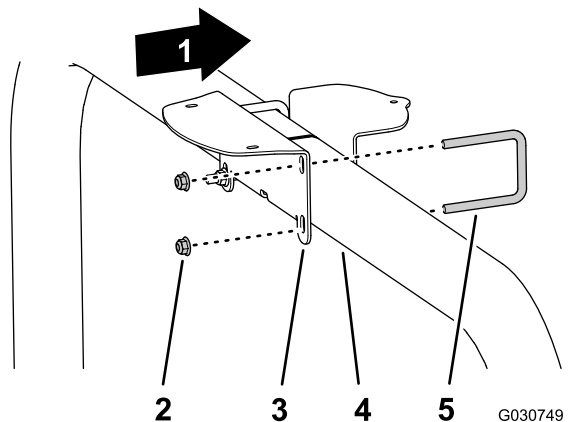

G030749

g030749

**Figure 124**

- 1. Front of the machine
- 2. Flange locknuts (3/8 inch)
- 3. Receiver mount
- 4. ROPS tube
- 5. U-bolt

- 3. Torque the nuts to 37 to 45 N·m (27 to 33 ft-lb).
- 4. Assemble the navigation receiver to the mount as follows:

### Assembling the Navigation Receiver to the Machine

- 1. Align the 3 threaded in the base of the navigation receiver to the 3 holes in the receiver mount (Figure 125).

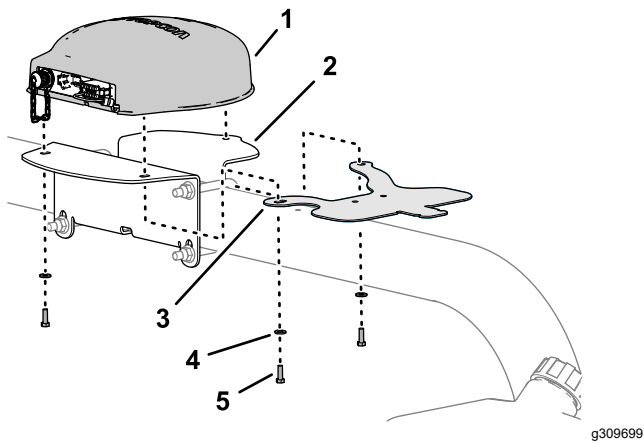

Figure 125

- |                          |                         |
|--------------------------|-------------------------|
| 1. Navigation receiver   | 4. Washer 5 mm          |
| 2. Receiver mount        | 5. Capscrew (5 x 16 mm) |
| 3. Modem-antenna bracket |                         |

- Align the hole and slot in the modem-antenna bracket with the holes in the receiver mount (Figure 125).
- Assemble the navigation receiver and antenna bracket to the mount (Figure 125) with the 3 hex-head bolt (5 x 16 mm) and 3 washers (5 mm).
- Torque the 3 bolts to 576 to 712 N·cm (51 to 63 in-lb).

- Remove the backing from the double sided adhesive liner at the bottom of the modem antenna (Figure 126).

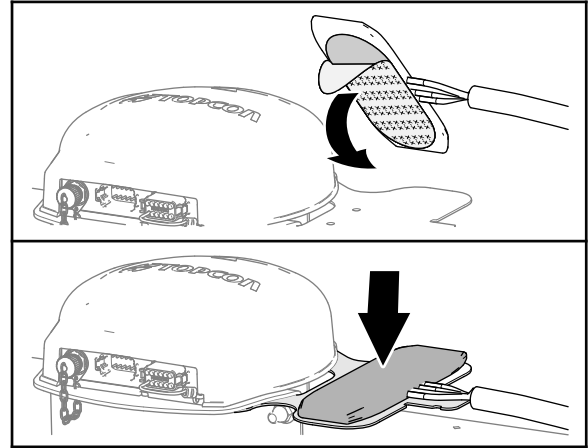

Figure 126

- Adhere the modem antenna to the top of the modem-antenna bracket as shown in Figure 126.
- Secure the antenna bracket with 3 cable ties as shown in Figure 127.

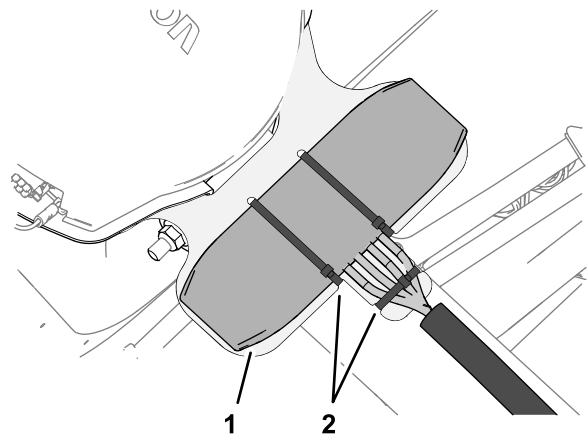

Figure 127

- |                  |               |
|------------------|---------------|
| 1. Modem antenna | 2. Cable ties |
|------------------|---------------|

- Secure the wire harness of the modem antenna to the bracket as shown in Figure 127.

## Routing the Modem-Antenna Harness

- Route the modem-antenna harness to the right, along the roll bar (Figure 128).

# 20

## Installing the Modem Antenna to the Machine

### Machines with Global Navigation Satellite System (GNSS) and the Modem Antenna.

#### Parts needed for this procedure:

1	Modem antenna—GeoLink precision spray system kit (Model 41633 or Model 41634)
7	Cable ties—GeoLink precision spray system kit (Model 41633 or Model 41634)

## Installing the Modem Antenna to the Navigation Receiver Mount

- Clean any grease or oil from the surface of the modem-antenna bracket.

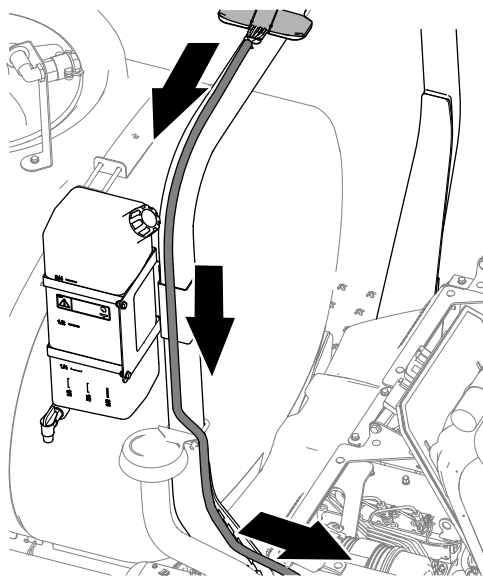

Figure 128

g309765

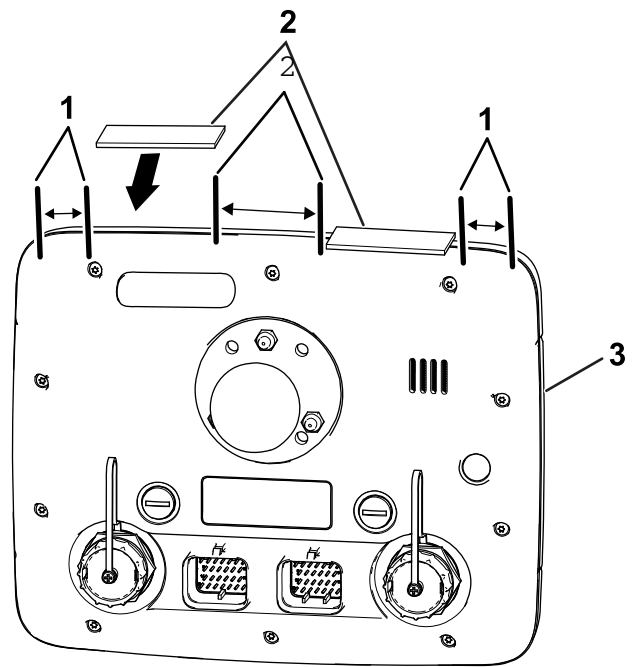

Figure 129

g198908

2. Route the harness down, and forward as shown in [Figure 128](#).
3. You will secure the modem-antenna harness to the roll bar in [Routing and Connecting the Data Cable to the Navigation Receiver](#) (page 63).

1. 51 mm (2 inches)
3. Sprayer monitor (back side)

2. Adhesive strips

4. Firmly press the adhesive strips to the top of the monitor.

# 21

## Installing the Monitor Visor

Parts needed for this procedure:

1	X25 Sprayer Monitor—GeoLink precision spray system kit (Model 41633 or Model 41634)
2	Adhesive strips
1	Threaded standoff
1	Display hood

## Applying the Adhesive Strips to the Sprayer Monitor

1. Clean the top surface of the X25 sprayer display with rubbing alcohol and a clean rag.
2. Remove the backing from the 2 adhesive strips.
3. At the top of the sprayer monitor, align the strips to the sprayer monitor as shown in [Figure 129](#).

# Assembling the Display Hood to the Sprayer Monitor

1. At the back of the sprayer monitor and with the 2 connectors (26 pin) aligned down, remove the top locknut (5 mm) from the stud for the ball-pivot fitting (A of [Figure 130](#)).

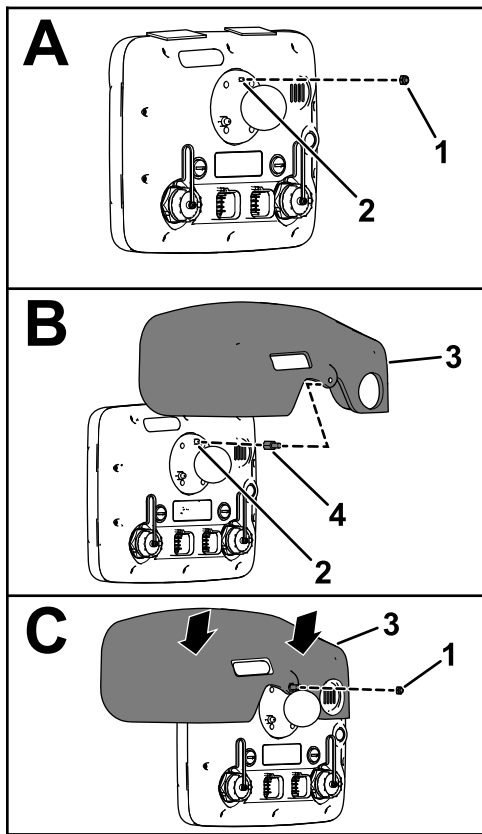

**Figure 130**

g198738

- |  |                      |
|--|----------------------|
| 1. Locknut (5 mm)  | 3. Display hood      |
| 2. Stud—5 mm (sprayer monitor at the ball-pivot fitting) | 4. Threaded standoff |

2. Apply a coat of thread-locking compound (wicking—medium-high strength) to the threads

for the nut portion of the threaded standoff ([Figure 131](#)).

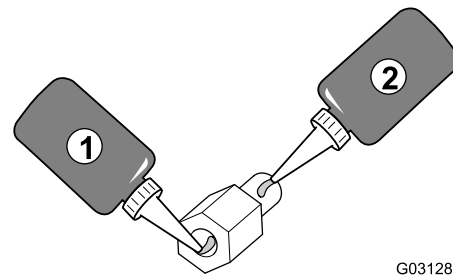

G031280

g031280

**Figure 131**

- |  |  |
|--|--|
| 1. Thread-locking compound (wicking—medium-high strength)—nut threads of the threaded standoff | 2. Thread-locking compound (wicking—medium-high strength)—stud threads |
|--|--|

3. Thread the standoff into the stud for the ball-pivot fitting (B of [Figure 130](#)) and torque the standoff to 250 N·cm (22 in-lb).
4. Apply a coat of thread-locking compound (wicking—medium-high strength) to the threads for the stud portion of the threaded standoff ([Figure 131](#)).
5. Remove the backing from the 2 adhesive strips that you applied in [Applying the Adhesive Strips to the Sprayer Monitor \(page 58\)](#).
6. Align the hole in the display hood with the stud portion of the threaded standoff (B of [Figure 130](#)).
7. Assemble the hood to the monitor (C of [Figure 130](#)) with the locknut (5 mm) that you removed in step 1.

**Note:** Press down on the areas of the top of the hood with the adhesive strips underneath.

8. Torque the nut to 250 N·cm (22 in-lb).

# 22

## Installing the Sprayer Monitor

### Parts needed for this procedure:

1	Ball mount—GeoLink precision spray system kit (Model 41633 or Model 41634)
1	Monitor arm—GeoLink precision spray system kit (Model 41633 or Model 41634)
1	Stiffener bracket
4	Flange-head bolt (1/4 x 1-1/2 inches)
4	Washer (1/4 inch)
4	Flange locknut (1/4 inch)

### Preparing the Dash Panel

1. Locate the 4 hole punchouts (1/4 inch) in the dash panel that are located to the left of the grab handle (Figure 132).

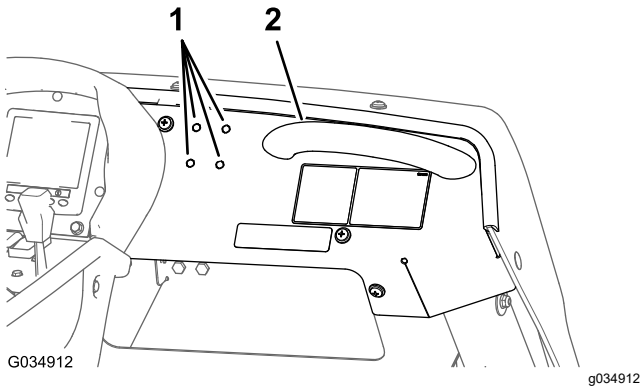

Figure 132

1. Hole punchouts (1/4 inch—dash panel)
  2. Grab handle
- 
2. Remove the 4 hole punchouts from the dash panel (Figure 132).

### Removing the Hood Bracket

1. Remove the 2 Phillips panhead screws (1/4 x 1 inch) and locknut (1/4 inch) that secure the hood bracket to the dash (Figure 133).

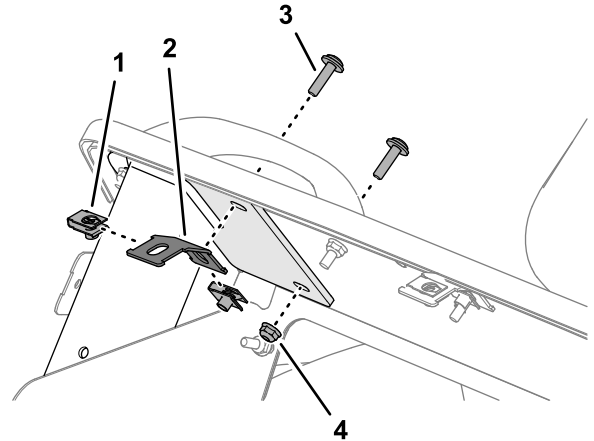

Figure 133

1. Clip nut (1/4 inch)
2. Hood bracket
3. Phillips panhead screw (1/4 x 1 inch)
4. Flange locknut (1/4 inch)

2. Remove the 2 clip nuts (1/4 inch) from the hood bracket (Figure 133).

**Note:** Retain the Phillips panhead screws, flange locknut, and clip nuts; discard the hood bracket.

### Preparing the Stiffener Bracket

Assemble the clip nuts that you removed in [Removing the Hood Bracket \(page 60\)](#) onto the stiffener bracket as shown in Figure 134.

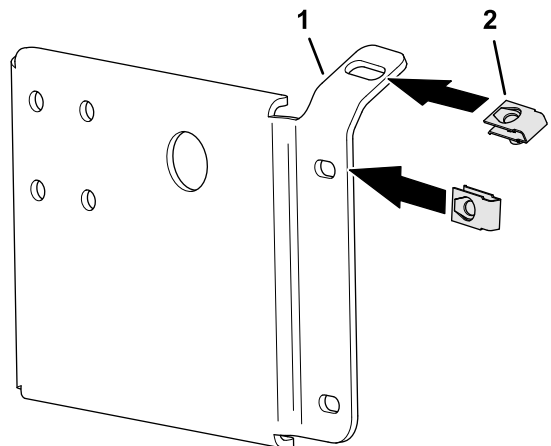
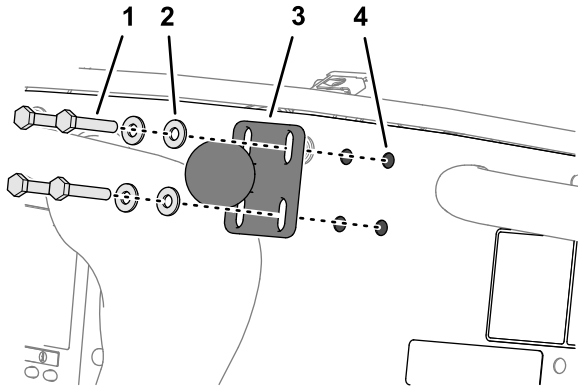

Figure 134

1. Stiffener bracket
2. Clip nut

## Installing the Ball-Pivot Mount

1. Assemble the ball-pivot mount to the dash with the 4 flange-head bolts (1/4 x 1-1/2 inch), stiffener plate, and flange locknut (1/4 inch) as shown in [Figure 135](#).



g310742

**Figure 135**

- |  |                      |
|--|----------------------|
| 1. Flange-head bolt (1/4 x 1-1/2 inch) | 3. Ball-pivot mount  |
| 2. Washer (1/4 inch)                   | 4. Hole (dash panel) |

2. Loosely assemble the stiffener plate to the 4 flange-head bolts (1/4 x 1-1/2 inch) with 4 locknuts (1/4 inch) as shown in [Figure 136](#).

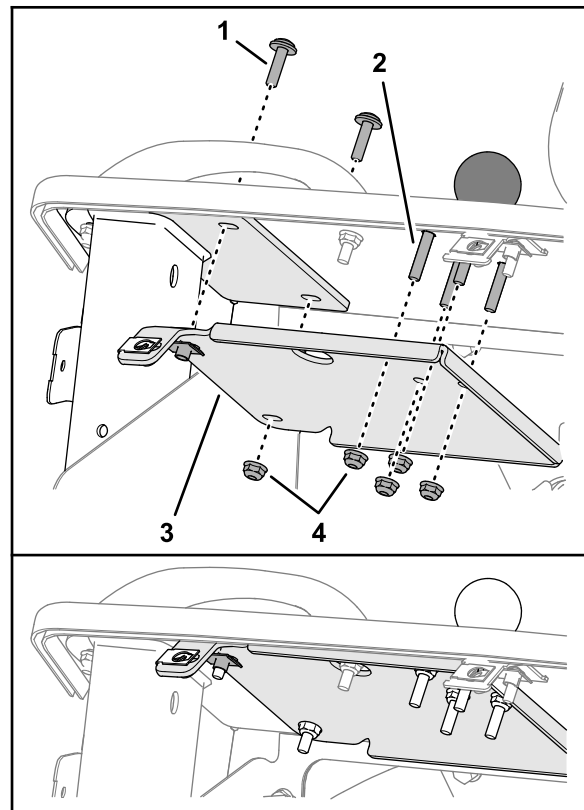

g310744

**Figure 136**

- |  |                              |
|--|------------------------------|
| 1. Phillips panhead screw (1/4 x 1 inch) | 3. Stiffener plate           |
| 2. Flange-head bolt (1/4 x 1-1/2 inch)   | 4. Flange locknut (1/4 inch) |

3. Loosely assemble stiffener plate with the 2 Phillips panhead screw (1/4 x 1 inch) and flange locknut (1/4 inch) that you removed in [Removing the Hood Bracket \(page 60\)](#).
4. Torque the flange-head bolts, Phillips panhead screws, and flange locknut to 1,163 to 1,435 N-cm (103 to 127 in-lb)

## Mounting the Sprayer Monitor to the Dash

1. Loosen the knob of the monitor arm until you can slip both the ball pivot for the fitting at the back of the sprayer monitor and the ball pivot for the mount at the dash panel into the socket monitor arm ([Figure 137](#)).

# 23

## Installing the Wire Harnesses for the Navigation Components

Parts needed for this procedure:

1	Data and electrical harness—GeoLink precision spray system kit (Model 41633 or Model 41634)
8	Cable tie—GeoLink precision spray system kit (Model 41633 or Model 41634)

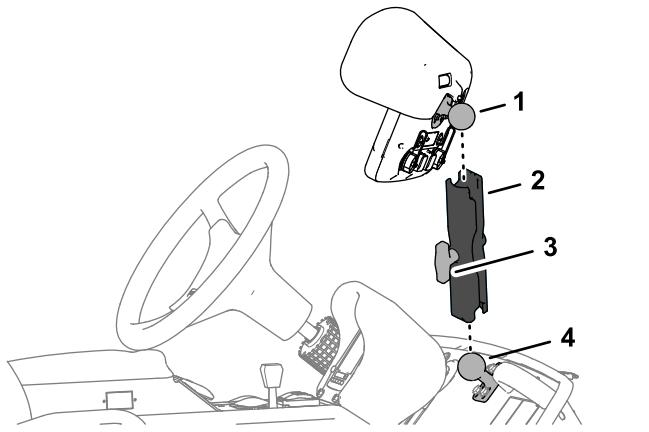

Figure 137

1. Ball pivot
2. Monitor arm
3. Knob
4. Ball-pivot mount

2. From the driver's seat (left seat), adjust to position of the sprayer monitor so that you can easily view the display screen (Figure 137).
3. Tighten the knob for the monitor arm by hand (Figure 137).

## Identifying the Navigation-Data and Electrical Harness

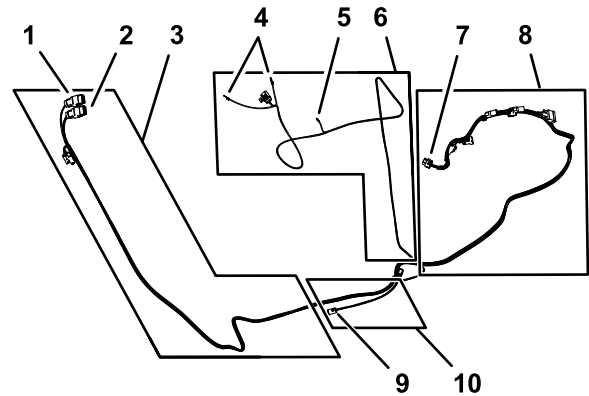

Figure 138

1. 12-socket connector—navigation receiver AGI 4 A KEY (GREY)
2. 12-socket connector—navigation receiver AGI 4 B KEY (BLACK)
3. 302 cm (119 inches) data-harness branch (navigation receiver)
4. Ring terminals (to battery positive and battery negative)
5. Socket connector (switched power)
6. 270.5 cm (106-1/2 inch) power-harness branch
7. 26-socket connector—(sprayer monitor)
8. 226 cm (89 inches) data-harness branch (sprayer monitor)
9. 4-pin connector (rear harness interface—CAN 2 ASC 10 BUS)
10. 34 cm (13-1/2 inches) data-harness branch (rear harness interface)

# Routing and Connecting the Data Cable to the Navigation Receiver

1. Route the 302 cm (119 inches) branch of the data-harness into the right side of the engine compartment (adjacent to the air filter for the engine) and rearward under the bottom right area of the rear engine shroud (Figure 139).

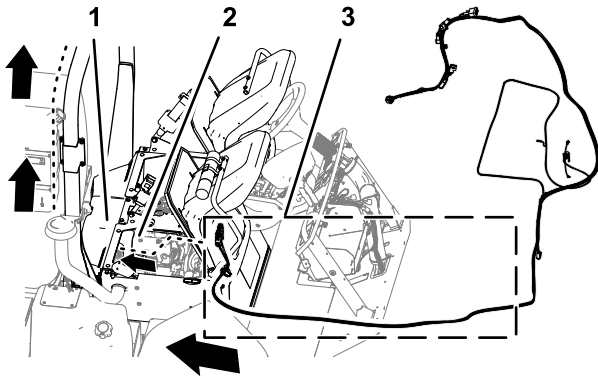

Figure 139

g310849

1. Rear engine shroud
2. Engine compartment
3. 302 cm (119 inches) data-harness branch (navigation receiver)

2. Route the 302 cm (119 inches) branch of the data harness along the right ROPS tube with the 12-socket connector (gray) and 12-socket connector (black) up toward the navigation receiver (Figure 140).

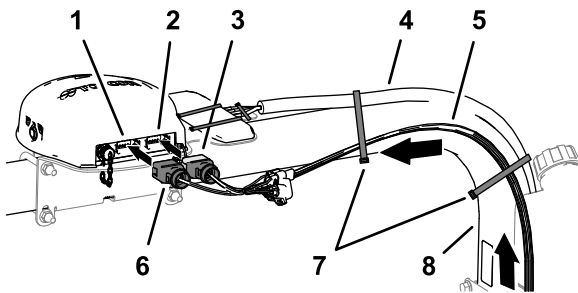

Figure 140

g312024

1. 12-pin connector left (gray)—navigation receiver
2. 12-pin connector right (black)—navigation receiver
3. 12-socket connector—data harness labeled AGI 4 B KEY (BLACK)
4. Modem-antenna harness
5. 302 cm (119 inches) data-harness branch
6. 12-socket connector—data harness labeled AGI 4 A KEY (GREY)
7. Cable ties
8. Right ROPS tube

3. Align the 2 keys at the long face of the 12-socket connector of the data harness labeled AGI 4 A KEY (GREY) with the 2 key slots in the bottom,

horizontal wall of the left (gray) 12-pin connector of the navigation receiver (Figure 141).

**Note:** Use caution when connecting wire harness to the navigation receiver; the alignment keys of the harness connectors are unique to the keyways of the pin connectors of the navigation receiver.

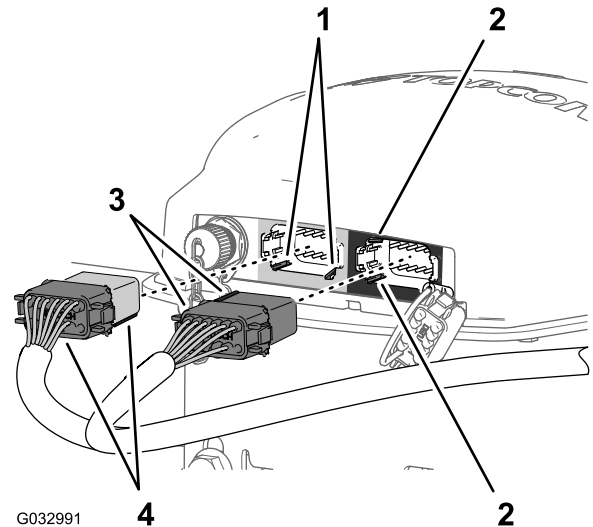

Figure 141

G032991

g032991

1. Key slots—bottom, horizontal wall (left gray) 12-pin connector—navigation receiver
2. Key slots—left, vertical wall (right black) 12-pin connector—navigation receiver
3. Alignment keys—short face (AGI 4 B KEY (BLACK) 12-socket connector—data harness)
4. Alignment keys—long face (AGI 4 A KEY (GREY) 12-socket connector—data harness)

4. Plug the AGI 4 A KEY (GREY) connector of the data harness into the left (gray) 12-pin connector of the navigation receiver until the connector locks snap together securely (Figure 141).
5. Align the 2 keys at the short side of the 12-socket connector—data harness labeled AGI 4 B KEY (BLACK) with the 2 key slots in the left, vertical wall of the right (black) 12-pin connector of the navigation receiver (Figure 141).

**Note:** Use caution when connecting wire harness to the navigation receiver; the alignment keys of the harness connectors are unique to the keyways of the pin connectors of the navigation receiver.

6. Plug the AGI 4 B KEY (BLACK) connector of the data harness into the right (black) 12-pin connector of the navigation receiver until the connector locks snap together securely (Figure 141).

- Secure the 302 cm (119 inches) branch of the data harness to the right ROPS tube with cable ties as shown in [Figure 140](#).

**Note:** Ensure that the cable is slack between the 12-socket connectors and the cable tie.

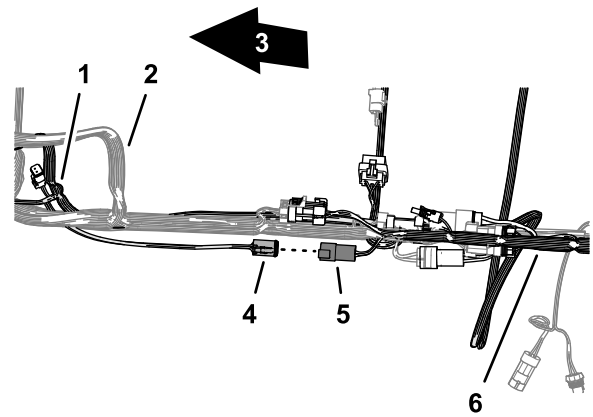

**Figure 143**

g310869

- 34 cm (13-1/2 inches) data-harness branch (navigation-data and electrical harness)
- Front wire harness of the machine
- Front of the machine
- 4-pin connector (labeled CAN 2 ASC 10 BUS—data-harness branch)
- 4-socket connector (unlabeled ASC 10 power and CAN—rear GeoLink wire harness)
- Rear GeoLink wire harness

## Connecting the Navigation-Data and Electrical Harness to the Rear GeoLink Harness

- Route the 302 cm (119 inches) data-harness branch of the electrical harness ([Figure 142](#)) with the 4-pin connector labeled CAN 2 ASC 10 BUS down to the area where the front and rear wire harness for the machine connect; refer to [Figure 92](#) in [Connecting the Front and Rear Wire Harnesses](#) (page 42).

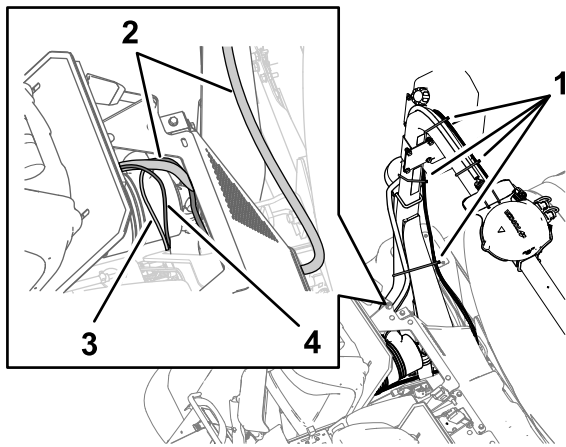

**Figure 142**

g312049

- Cable ties
- 302 cm (119 inches) data-harness branch (navigation receiver)
- 34 cm (13-1/2 inches) data-harness branch (4-pin connector CAN 2 ASC 10 BUS)
- 270.5 cm (106-1/2 inch) power-harness branch

- Route the 34 cm (13-1/2 inches) data-harness branch ([Figure 142](#)) with the 4-pin connector labeled CAN 2 ASC 10 BUS down to the area where the front and rear wire harness for the machine connect; refer to [Figure 92](#) in [Connecting the Front and Rear Wire Harnesses](#) (page 42).
- Connect the 4-pin connector of the data-harness branch labeled CAN 2 ASC 10 BUS into the 4-socket connector of the rear GeoLink harness for the CAN 2 / sprayer-controller circuit ([Figure 143](#)).

## Removing the Terminating Resistor

Remove the terminating resistor from the 6-socket connector of the data cable as shown in [Figure 144](#).

**Note:** You no longer need the terminating resistor.

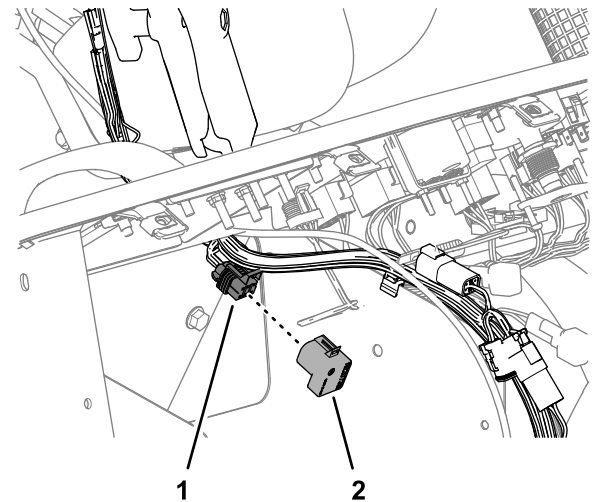

**Figure 144**

g314497

- 6-socket connector of the data cable
- Terminating resistor

# Routing the Navigation-Data and Electrical Harness to the Battery

1. Route the 270.5 cm (106-1/2 inch) power branch of the navigation-data and electrical harness across the seat-box angle and down along the left support for the engine shroud (Figure 145).

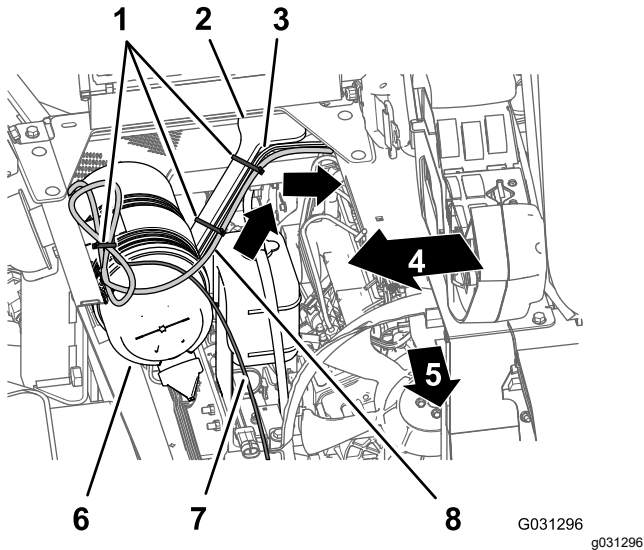

**Figure 145**

- |   |  |
|---|--|
| 1. Cable ties   | 5. Front of the machine  |
| 2. Engine-shroud support                                | 6. Air filter (engine)   |
| 3. 241 cm (95 inch) branch (front machine wire harness) | 7. 226 cm (89 inches) data-harness branch (sprayer monitor)                      |
| 4. Right side of the machine                            | 8. 270.5 cm (106-1/2 inch) power branch (navigation-data and electrical harness) |

2. Secure the harness to the engine-shroud support with cable ties (Figure 145).
3. Route the 270.5 cm (106-1/2 inch) power branch along the left support for the engine shroud and under the left frame tube (Figure 146).

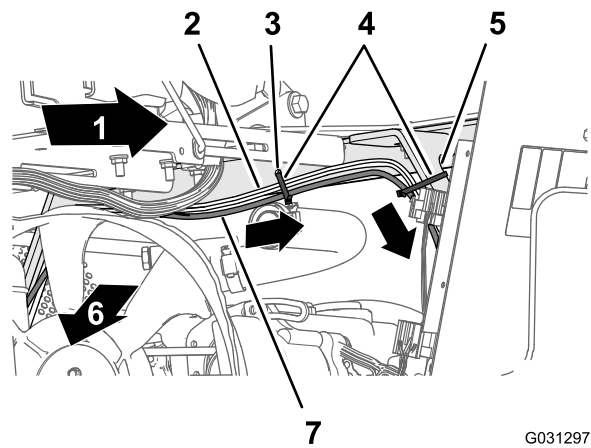

**Figure 146**

- |   |  |
|---|--|
| 1. Left side of the machine                             | 5. Engine-shroud support   |
| 2. 241 cm (95 inch) branch (front machine wire harness) | 6. Front of the machine  |
| 3. Hole in the seat-box angle                           | 7. 270.5 cm (106-1/2 inch) power branch (navigation-data and electrical harness) |
| 4. Cable ties   |  |

4. Secure the harness to the hole in the seat-box angle and the engine-shroud support with 3 cable ties (Figure 146 and Figure 147).

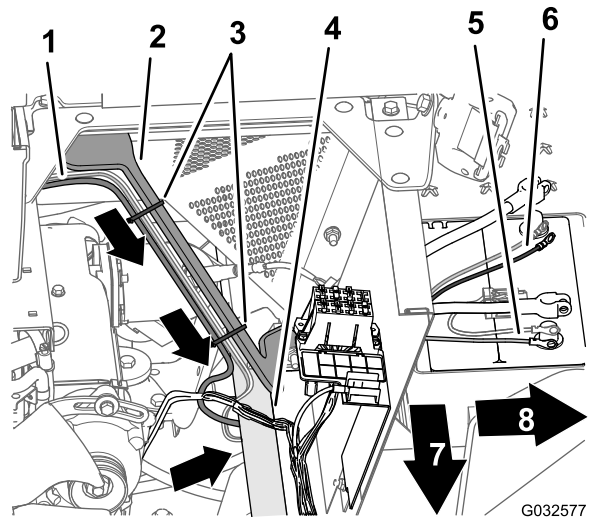

**Figure 147**

- |   |  |
|---|--|
| 1. 165 cm (65 inch) branch (front machine wire harness) | 5. Negative-ring terminal (black wire)—power branch (navigation-data and electrical harness) |
| 2. Engine-shroud support                                | 6. Positive-ring terminal (red wire)—power branch (navigation-data and electrical harness)   |
| 3. Cable ties   | 7. Front of the machine  |
| 4. Left frame tube                                      | 8. Left side of the machine  |

- Route the 10 A fuse and the positive- and negative-ring terminals of the 220 cm (86-5/8 inch) branch of the electrical-harness for the navigation system to the top of the battery (Figure 147).

**Note:** You will complete the installation of the ring terminals in [Routing the Navigation-Data and Electrical Harness to the Battery](#) (page 65).

## Routing and Connecting the Data Cable to the Sprayer Monitor

- At the right side of the engine compartment, route the 226 cm (89 inches) data-harness branch for the sprayer monitor forward of the air filter for the engine and down toward the lower right corner of the radiator (Figure 148).

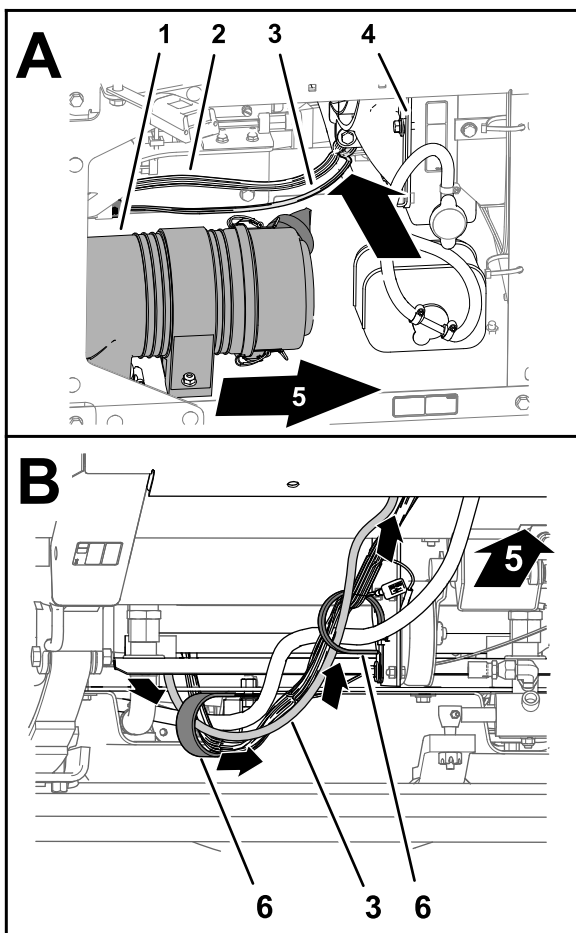
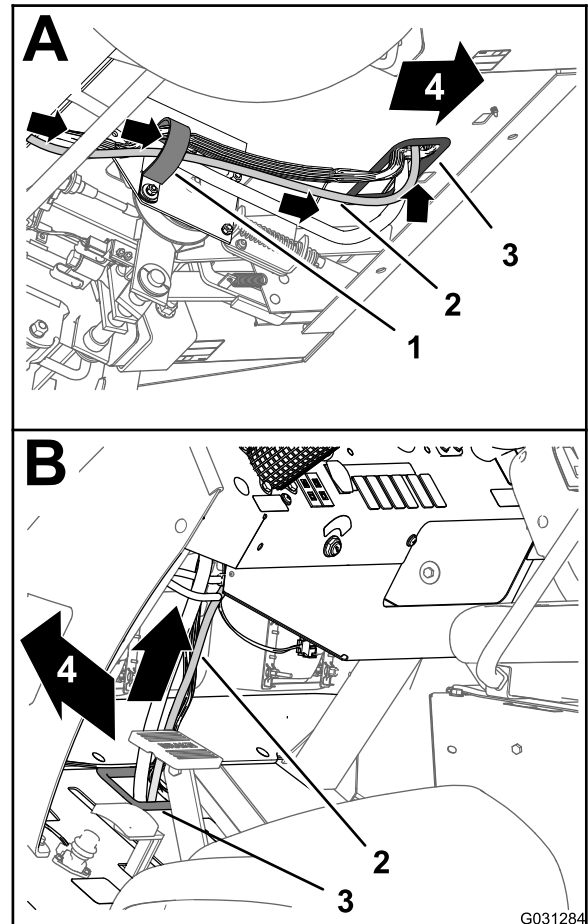

**Figure 148**

g310897

- |   |                         |
|---|-------------------------|
| 1. Air filter (engine)                                      | 4. Radiator             |
| 2. Front wire harness of the machine                        | 5. Front of the machine |
| 3. 226 cm (89 inches) data-harness branch (sprayer monitor) | 6. R-clamps             |

- Route the route the 226 cm (89 inches) data-harness branch forward and through the 2 R-clamps at the bottom of the machine (Figure 148).
- Route the route the 226 cm (89 inches) data-harness branch forward and up through grommet that surrounds the hole in the floor panel (Figure 149).



G031284

g031284

**Figure 149**

- |   |                         |
|---|-------------------------|
| 1. R-clamp  | 3. Grommet (floor pan)  |
| 2. 226 cm (89 inches) data-harness branch (sprayer monitor) | 4. Front of the machine |

- Secure the 226 cm (89 inches) data-harness branch to the front wire harness of the machine with 3 cable ties.
- Route the route the 226 cm (89 inches) data-harness branch up and along the front wire harness of the machine (Figure 149).
- Route the route the 226 cm (89 inches) data-harness branch up through grommet that surrounds the hole in the dash panel (Figure 150).

# 24

## Assembling the Modem Power Harness to the Machine

Parts needed for this procedure:

1	Modem power harness—1850 mm (72-7/8 inches)—GeoLink precision spray system kit (Model 41633 or Model 41634)
5	Cable ties—GeoLink precision spray system kit (Model 41633 or Model 41634)

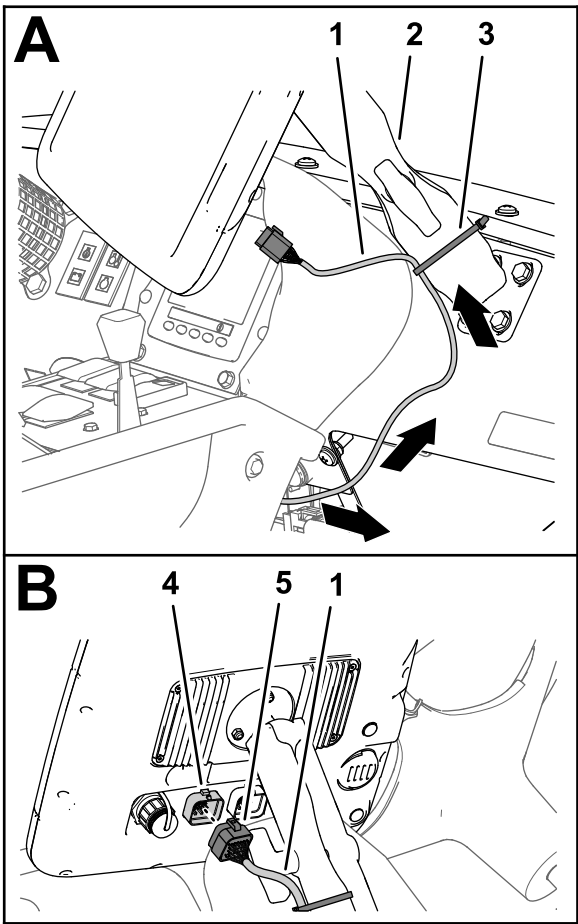

Figure 150

g190329

1. 226 cm (89 inches) data-harness branch (sprayer monitor)
  2. Monitor arm
  3. Cable tie
  4. 26-pin connector (sprayer monitor)
  5. 26-socket connector—data harness (sprayer monitor)
- 
7. Align the 26-socket connector of the data harness branch with the 26-pin connector of the sprayer monitor and press the socket connector into the pin connector until the connector latches securely (Figure 150).
  8. Secure the 226 cm (89 inches) data-harness branch to the monitor arm with a cable tie (Figure 150).

## Routing the Modem Power Harness

1. Between the fuel tank bracket and the right, front fender, route the tab terminal (labeled SWITCHED) and 2 ring terminal (labeled BATTERY and GROUND) of the modem power harness under the frame of the machine (Figure 151).

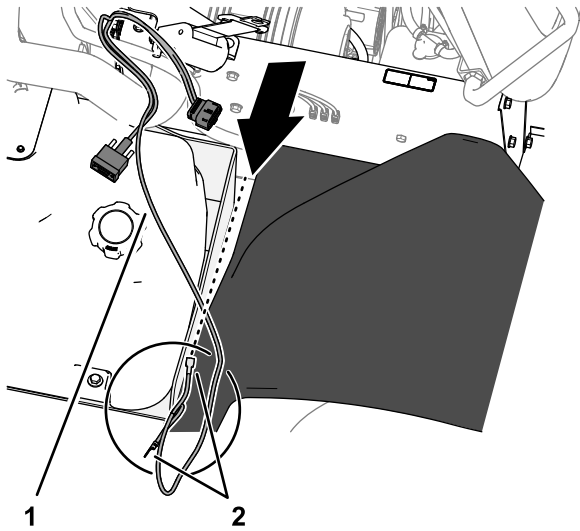

Figure 151

g310037

1. Modem power harness
2. Wire terminals

2. At the inboard side of the right seat box, route the modem power harness forward and power harness connector labeled RS232 along the machine wire harness (Figure 152).

**Note:** The connector labeled RS232 is not used.

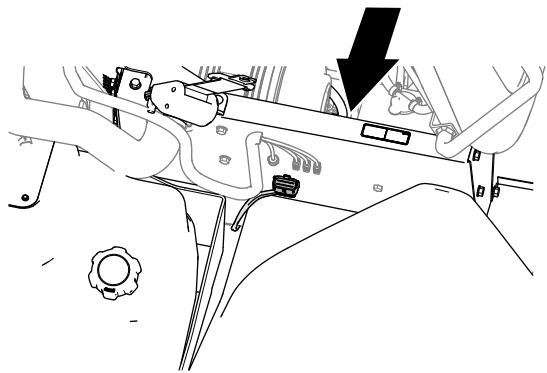

g310038

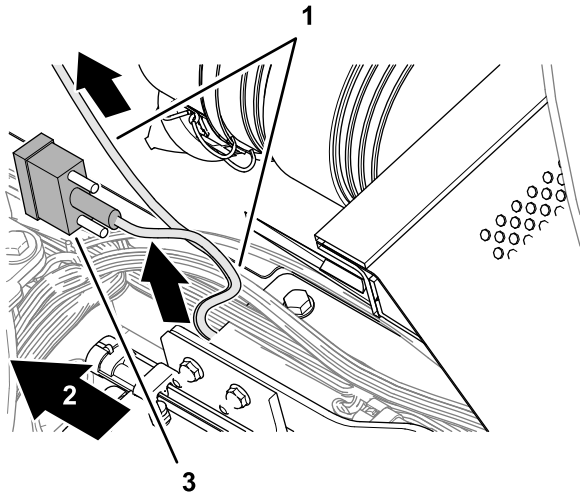

g310039

**Figure 152**

1. Modem power harness
2. Front of the machine
3. 9-pin connector (labeled RS232—not used)

3. Route the modem power harness across the top of the radiator, along the machine wire harness (Figure 153).

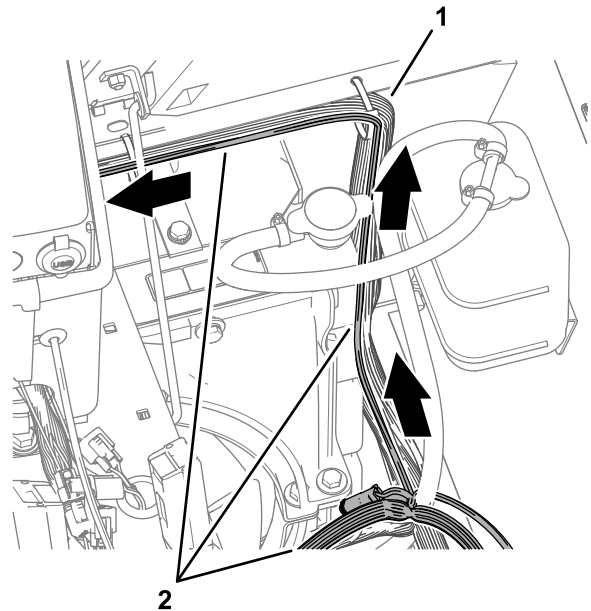

g301675

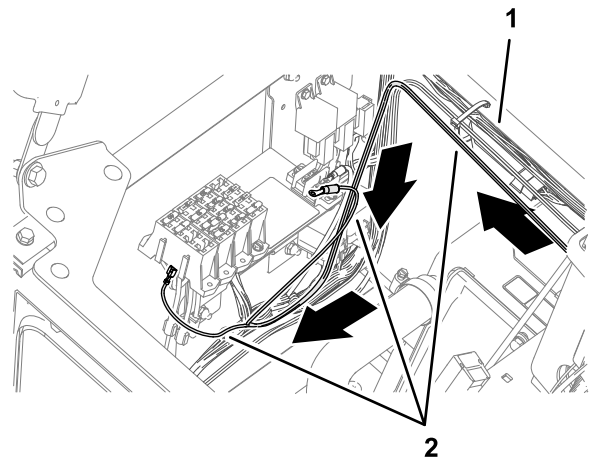

g301795

**Figure 153**

1. Machine wire harness
2. Modem power harness

## Connecting the Wire Harness to the Fuse Block

1. Plug the terminal of the modem power harness labeled SWITCHED into the socket connector for options power of the fuse block (Figure 154).

**Note:** If fuse block of your machine does not have an available options-power circuit, install an additional options-fuse block; refer to your authorized Toro distributor.

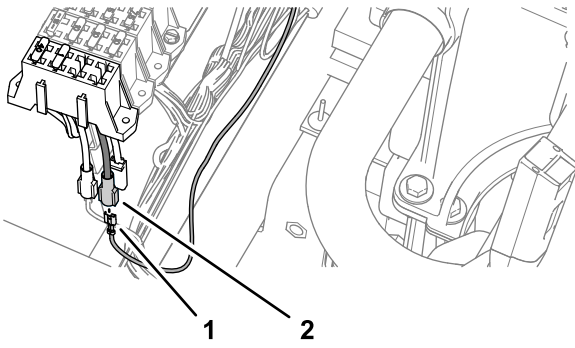
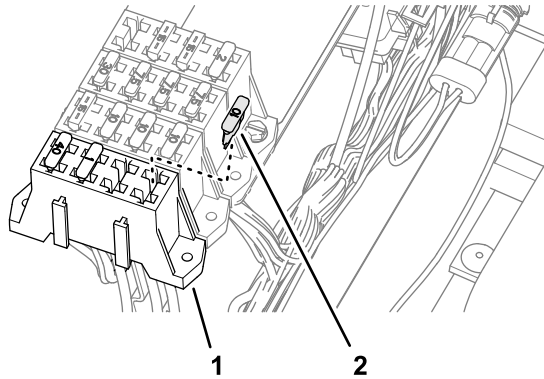

**Figure 154**

g301670

1. Terminal (labeled BATTERY—modem power harness)
2. Socket connector (options power—fuse block)

2. Insert the fuse (10 A) into the fuse-block socket (Figure 155) for the options power circuit that you used in step 1.



**Figure 155**

g301672

1. Fuse block
2. Fuse (10 A)

3. Secure the switched power and ground branch of the kit wire harness to the machine wire harness with 5 cable ties.

## Routing the Harness to the Battery

1. Route the ring terminals of the harness labeled BATTERY and GROUND rearward, and over the seat support (Figure 156).

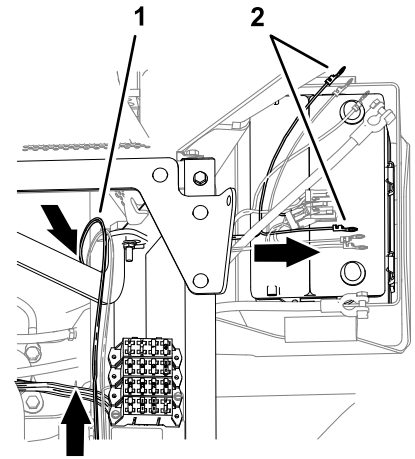

**Figure 156**

g315080

2. Route the ring terminals under the left frame tube and across the top of the battery (Figure 156).

**Note:** You will assemble the ring terminals to the battery cables in [Assembling the Rear GeoLink Harness, Navigation-Data and Electrical Harness, and Modem Power Harness to the Battery Cables](#) (page 81).

# 25

## Assembling the Modem Data Harness to the Machine

### Parts needed for this procedure:

1	Modem data harness—300 cm (118 inches)—GeoLink precision spray system kit (Model 41633 or Model 41634)
8	Cable ties—GeoLink precision spray system kit (Model 41633 or Model 41634)

## Connecting the Modem Data Harness to the Sprayer Display

1. Align the modem data harness with the RS-232 connector labeled X-CONSOLE toward the sprayer monitor (Figure 157).

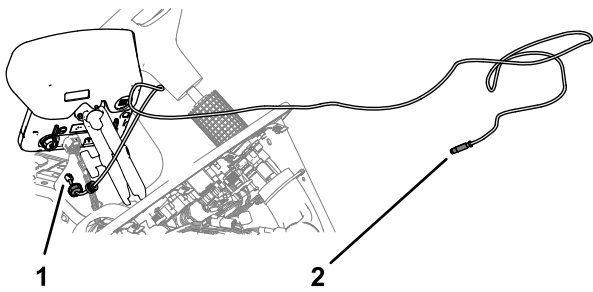
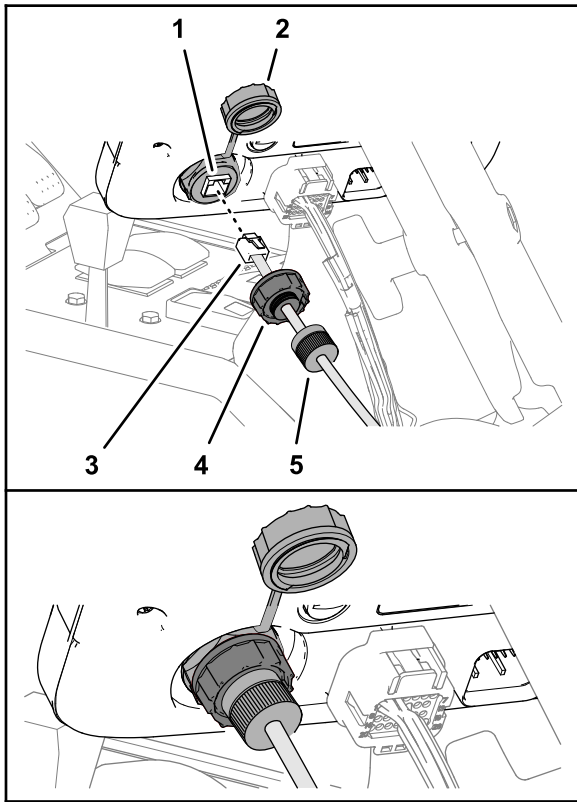

**Figure 157**

g310205

1. RJ45 connector (labeled X-CONSOLE—modem data harness)
2. 4-pin connector (labeled ETHERNET CL-55—modem data harness)

2. At the front of the sprayer display, remove the cap from the RJ45 port (Figure 158).



**Figure 158**

g310206

1. RJ45 port (sprayer display)
2. Cap
3. RJ45 connector (labeled X-CONSOLE—modem data harness)
4. Port seal nut
5. Compression nut

3. Plug the RJ45 connector of the modem data cable labeled x-CONSOLE into the RJ45 port of the sprayer display (Figure 158).
4. Assemble the port seal nut over the RJ45 port of the sprayer display, and tighten the seal nut (Figure 158).

5. Assemble compression nut over port seal nut, and tighten the compression nut (Figure 158).

## Routing the Modem Data Cable

1. Route the modem data cable through the storage compartment (Figure 159).

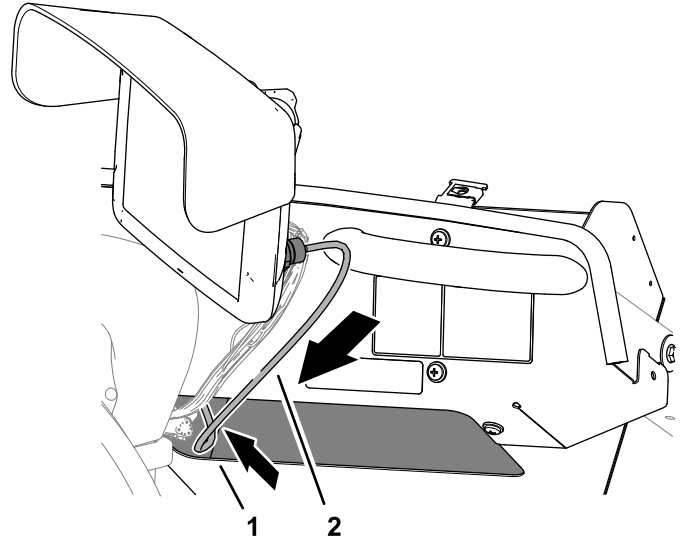
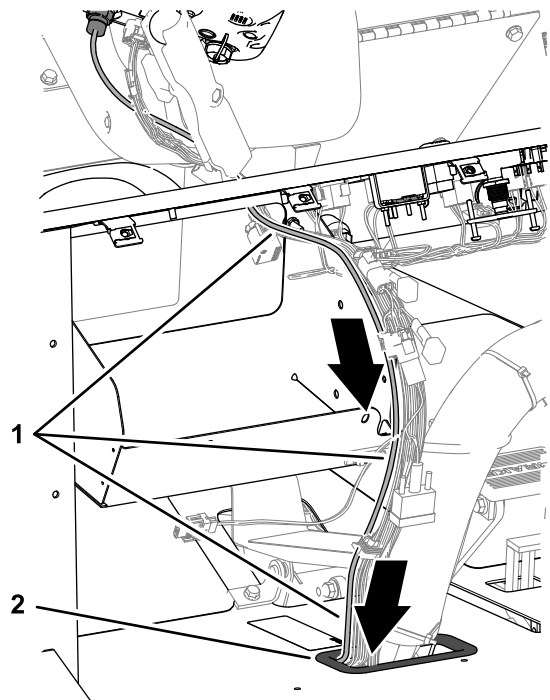

**Figure 159**

g310207

1. Storage compartment
2. Modem data cable

2. Route the modem data cable along the wire harness of the machine, and through the grommet in the floor plate (Figure 160).

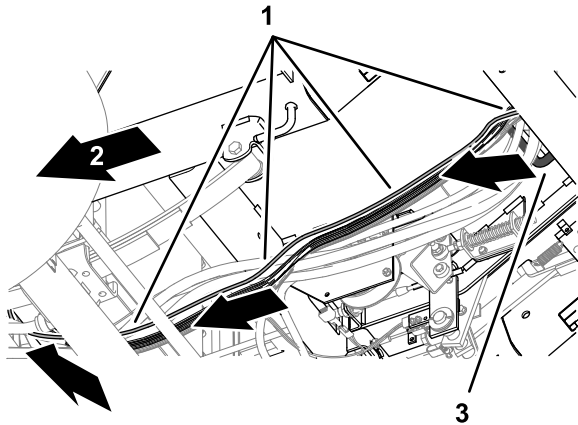

**Figure 160**

g310208

1. Modem data cable
2. Grommet (floor plate)

- Secure the modem data cable to the machine wire harnesses with 4 cable ties.
- At the bottom of the machine, route the modem data cable rearward, along the wire harness of the machine (Figure 161).

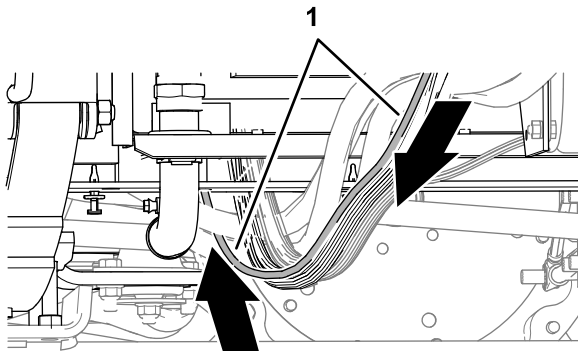

**Figure 161**

g310209

- Modem data cable
- Back of the machine
- Grommet (floor plate)

- At the rear side of the radiator, route the modem data cable upward (Figure 162).

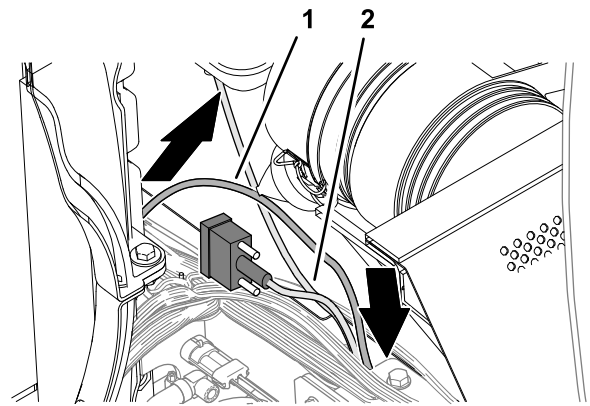

**Figure 162**

g310210

- Modem data cable

- Secure the modem data cable to the machine wire harnesses with 4 cable ties.
- Route the modem data cable along the modem power harness (Figure 163), out the right side of the machine, and between the fuel tank bracket and the right, front fender.



g310211

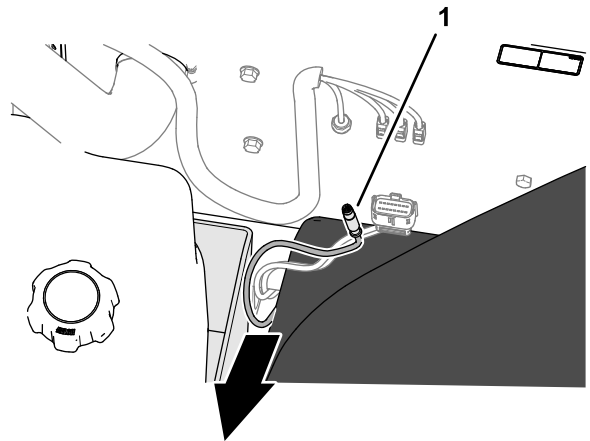

g310212

**Figure 163**

- Modem data cable
- Modem power harness

# 26

## Installing the CL-55 Modem

### Parts needed for this procedure:

1	CL-55 modem—GeoLink precision spray system kit (Model 41633 or Model 41634)
1	Modem bracket
	Capscrew (#10-24 x 1-1/2 inches)
	Spacer (1/4 x 3/4 inch)
2	Locknut (#10-24)

### Preparing the Machine

- Remove the 2 flange locknuts (5/16 inch) and 2 flange-head bolts (5/16 x 1 inch) that secure the air-cleaner mount to the right seat-box panel (Figure 164).

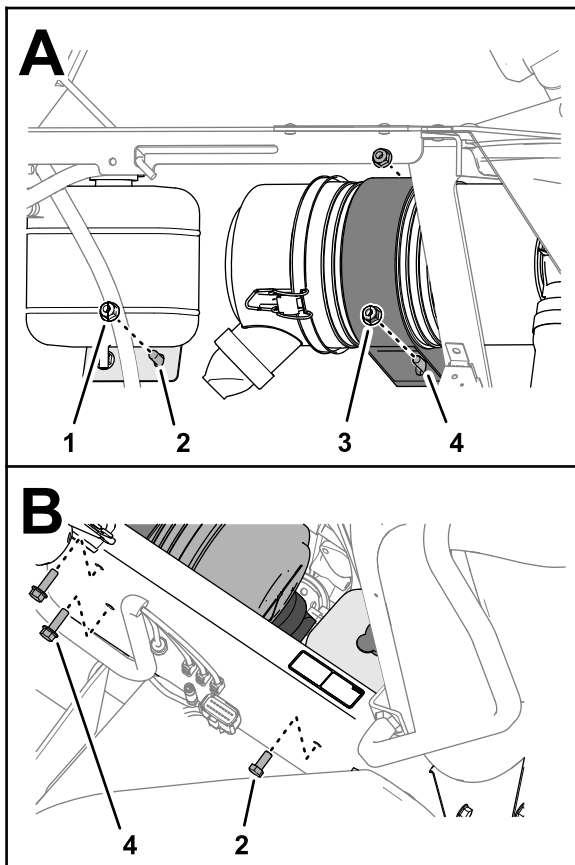

**Figure 164**

g310541

- |   |   |
|---|---|
| 1. Flange locknut (5/16 inch—coolant reservoir bracket)                     | 3. Flange locknut (5/16 inch—air-cleaner mount)       |
| 2. Capscrew (5/16 x 3/4 inch—rear position only, coolant reservoir bracket) | 4. Flange-head bolt (5/16 x 1 inch—air-cleaner mount) |

2. Remove the rear flange locknut (5/16 inch) and capscrew (5/16 x 3/4 inch) that secures the coolant reservoir bracket to the right seat-box panel (Figure 164).

## Connecting the Antenna Harness to the Modem

1. Plug the coaxial connector of the modem-antenna harness labeled WiFi into the coaxial port of the CL-55 modem marked WiFi/BT, and tighten the coaxial connector (Figure 165).

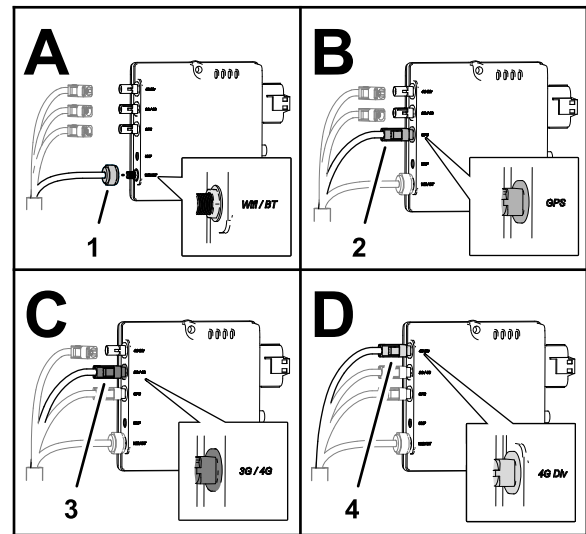

**Figure 165**

g310538

- |  |   |
|--|---|
| 1. Coaxial connector (labeled WiFi—modem-antenna harness)              | 3. Violet coaxial push-in connector (labeled LTE-1—modem-antenna harness) |
| 2. Blue coaxial push-in connector (labeled GNSS—modem-antenna harness) | 4. Red coaxial push-in connector (labeled LTE-2—modem-antenna harness)    |

2. Plug the blue coaxial push-in connector of the modem-antenna harness labeled GNSS into the connector of the CL-55 modem marked GPS, until the connectors latch securely (Figure 165).
3. Plug the violet coaxial push-in connector of the modem-antenna harness labeled LTE-1 into the connector of the CL-55 modem marked 3G / 4G, until the connectors latch securely (Figure 165).
4. **CDMA Modems Only:** Plug the red coaxial push-in connector of the modem-antenna harness labeled LTE-2 into the connector of the CL-55 modem marked 4G DIV, until the connectors latch securely (Figure 165).

**Note:** The GSM modem does not have an LTE-2 connector.

## Connecting the Modem Data and Power Harnesses to the Modem

1. Plug the 4-pin connector of the modem data harness labeled ETHERNET CL55 into the 4-socket connector (unmarked) of the CL-55 modem, and tighten the knurled nut of the 4-pin connector (Figure 166).

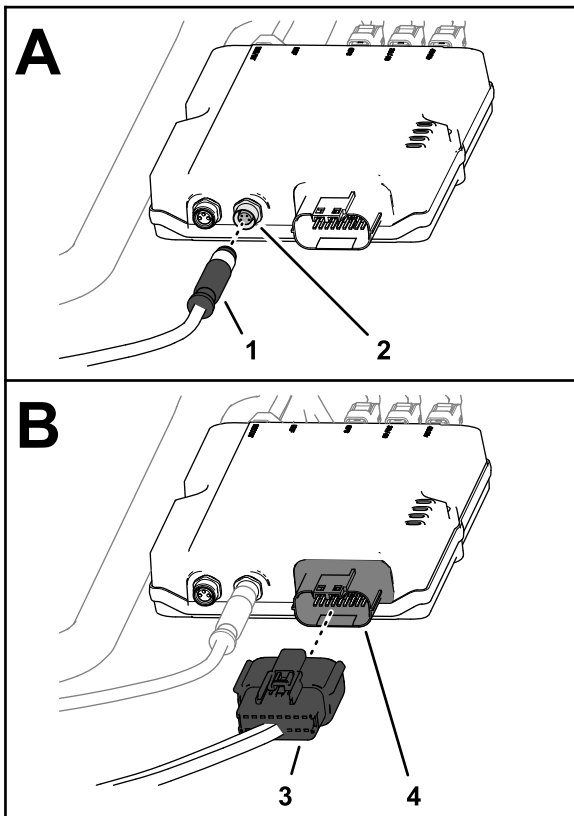

g310539

**Figure 166**

- |   |   |
|---|---|
| 1. 4-pin connector (labeled ETHERNET CL55—modem data harness) | 3. 18-socket connector (labeled CL55—modem power harness) |
| 2. 4-socket connector (unmarked—CL-55 modem)                  | 4. 18-pin connector (CL-55 modem)                         |

2. Plug the 18-socket connector of the modem power harness labeled CL55 into the 18-pin connector of the CL-55 modem (Figure 166).

## Installing the Modem to the Machine

1. Assemble the modem bracket to the CL-55 modem with 2 capscrews (#10-24 x 1-1/2 inches), 2 spacers (1/4 x 3/4 inch), and 2 locknuts (#10-24) as shown in Figure 167.

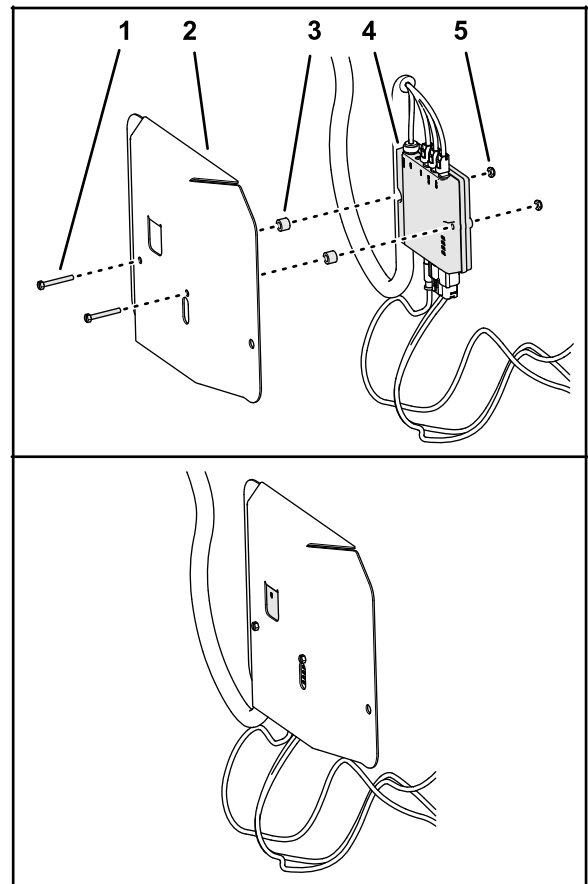

g310537

**Figure 167**

- |                                     |                     |
|-------------------------------------|---------------------|
| 1. Capscrew (#10-24 x 1-1/2 inches) | 4. CL-55 modem      |
| 2. Modem bracket                    | 5. Locknut (#10-24) |
| 3. Spacer (1/4 x 3/4 inch)          |                     |

2. Align the modem bracket to the right seat-box panel (Figure 168).

**Important:** Ensure that the wire harnesses are routed within the modem bracket.

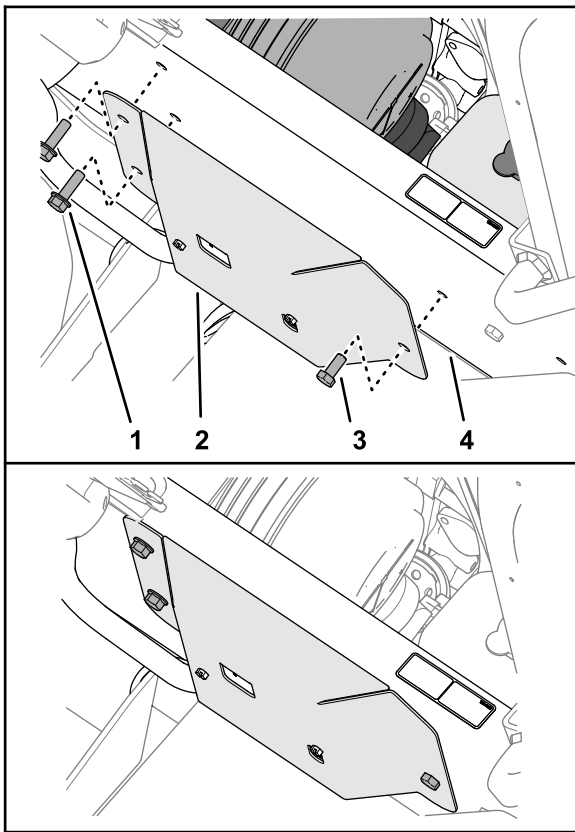
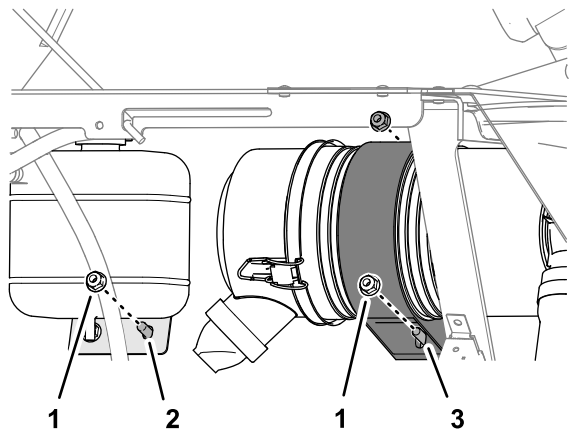

**Figure 168**

g310540

1. Flange-head bolt (5/16 x 1 inch)
2. Modem bracket
3. Capscrew (5/16 x 3/4)
4. Right seat-box panel

3. Assemble the modem bracket to the right seat-box panel and the air-cleaner mount (Figure 168 and Figure 169) with the 2 flange-head bolts (5/16 x 1 inch) and 2 flange locknuts (5/16 inch) that you removed in Preparing the Machine (page 71).



**Figure 169**

g310536

1. Flange locknut (5/16 inch)
  2. Capscrew (5/16 x 3/4—coolant reservoir bracket)
  3. Flange-head bolt (5/16 x 1 inch—air-cleaner mount)
- 
4. Assemble the modem bracket to the right seat-box panel and the coolant reservoir bracket (Figure 168 and Figure 169) with the capscrew (5/16 x 3/4) and flange locknut (5/16).
  5. Tighten the flange-head bolts, capscrew, and flange locknuts.

# 27

## Routing the ISO-CAN Bus Harness

### Parts needed for this procedure:

1	ISO-CAN bus harness—302 cm (119 inches—GeoLink precision spray system kit Model 41633 or Model 41634)
12	Cable ties—GeoLink precision spray system kit (Model 41633 or Model 41634)

## Connecting the ISO-CAN Bus Harness to the GeoLink Harness

### GeoLink Navigation Cable with a Convuluted-Tube Cover

1. At the front of the machine, align the 4-pin connector of the ISO-CAN bus harness—302 cm (119 inches) labeled To ISOBUS toward the dash panel (Figure 170).

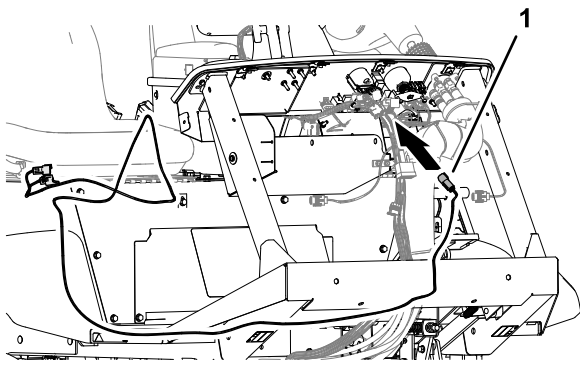

**Figure 170**

g308950

1. ISO-CAN bus harness—302 cm (119 inches) 4-pin connector labeled To ISOBUS

2. Remove the ISO bus terminator from the 4-socket connector of the GeoLink harness labeled CAN 1 ISOBUS TERMINATOR (Figure 171).

**Note:** You no longer need the cap.

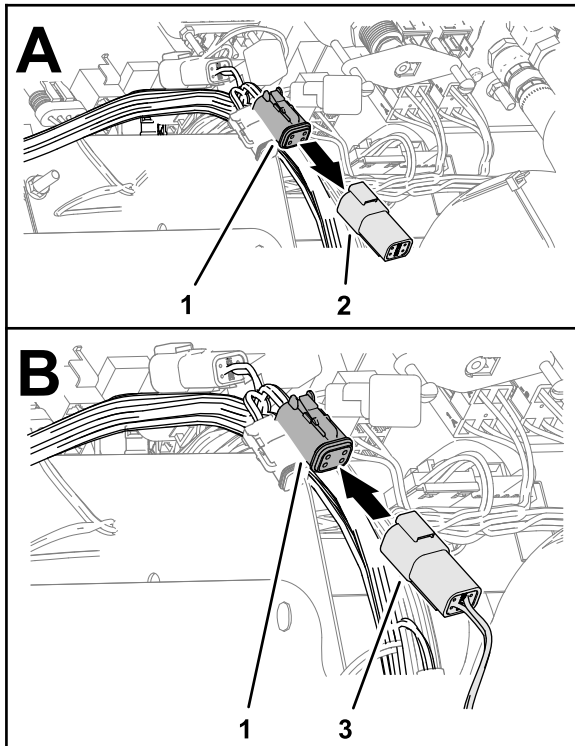

**Figure 171**

g308951

1. 4-socket connector (labeled CAN 1 ISOBUS TERMINATOR—GeoLink harness)
2. Terminator (ISO bus)
3. Plug the To ISOBUS connector of the ISO-CAN bus harness into the CAN 1 ISOBUS TERMINATOR connector of the GeoLink harness (Figure 171).

## Routing the Harness to the Console Base

### GeoLink Navigation Cable with a Convoluted-Tube Cover

1. Route the other end of the ISO-CAN bus harness through the grommet of the floor (Figure 172).

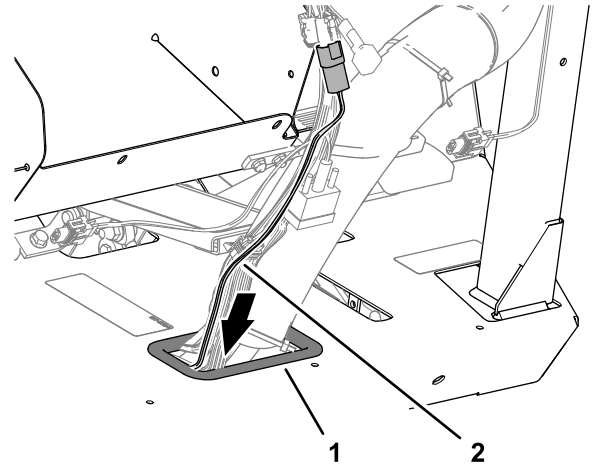
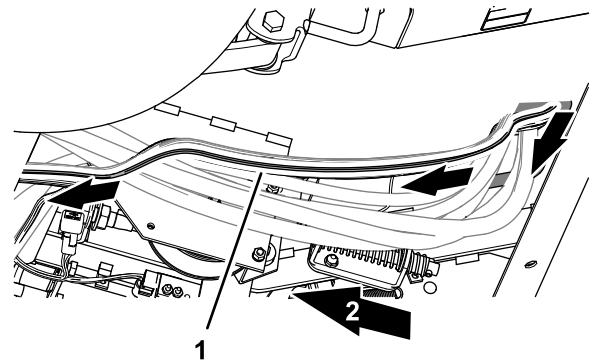

**Figure 172**

g308956

1. Grommet (floor)
2. ISO-CAN bus harness

2. Secure the ISO-CAN bus harness to the machine wire harness with 2 cable ties.
3. At the bottom of the machine, route the ISO-CAN bus harness along the wire harness of the machine (Figure 173).



**Figure 173**

g308957

1. ISO-CAN bus harness
4. Secure the ISO-CAN bus harness to the machine wire harness with 3 cable ties.
5. Rotate the passenger seat forward and support it with the prop rod.
6. At the right side of the radiator, rout the ISO-CAN bus harness up, along the machine wire harness, and toward the center console (Figure 174).

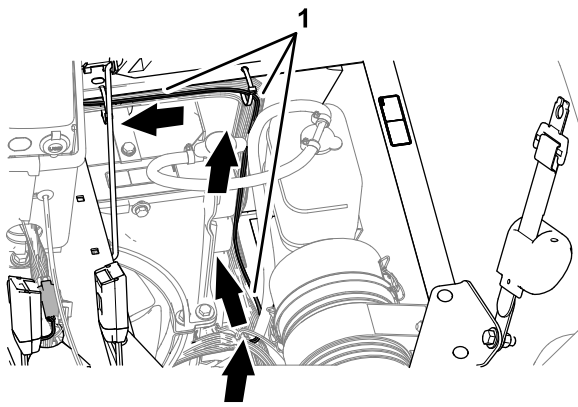
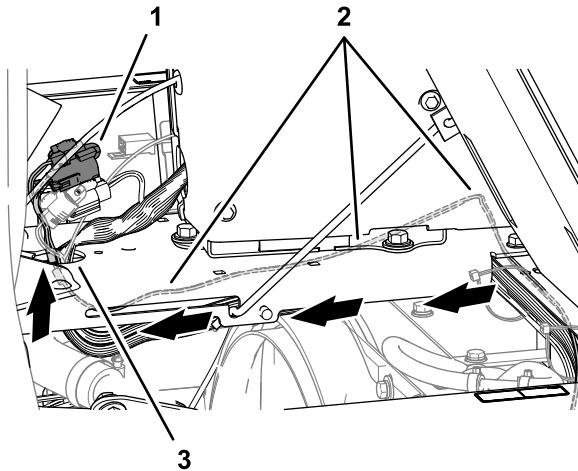

**Figure 174**

g308958

1. ISO-CAN bus harness

7. Route the ISO-CAN bus harness under the console base and along the machine wire harness (Figure 175).



**Figure 175**

g308959

1. 3-pin connector (labeled To TORO CANBUS) and 3-socket connector (labeled CAN PORT A)
2. ISO-CAN bus harness
3. Hole (console base)

8. Route the 3-pin connector (labeled To TORO CANBUS) and 3-socket connector (labeled CAN PORT A) of the ISO-CAN bus harness through the hole in the console base (Figure 175).
9. Secure the ISO-CAN bus harness to the machine wire harness with 6 cable ties.

## Connecting the ISO-CAN Bus Harness to the Machine Wire Harness

1. Remove the cap from the 3-socket connector of the machine wire harness (labeled CAN DIAGNOSTICS INTERCONNECT), as shown in Figure 176.

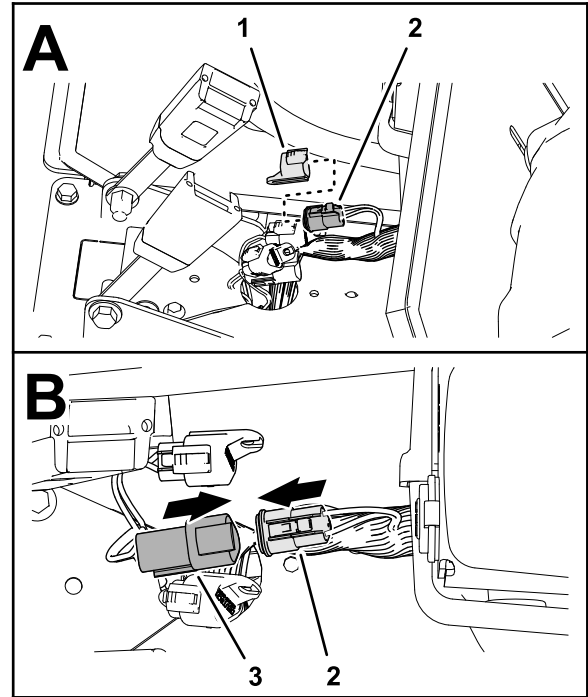

**Figure 176**

g308952

1. Cap
  2. 3-socket connector (labeled CAN DIAGNOSTICS INTERCONNECT—machine wire harness)
  3. 3-pin connector (labeled To TORO CANBUS—ISO-CAN bus harness)
2. Plug the 3-pin connector of the ISO-CAN bus harness (labeled To TORO CANBUS) into the 3-socket connector of the machine wire harness (labeled CAN DIAGNOSTICS INTERCONNECT), as shown in Figure 176.

# 28

## Removing the CAN Bus Resistor

No Parts Required

### Removing the Console Side Panel

1. Lower the passenger seat.
2. Remove 4 flange-head capscrews (1/4 x 3/4 inch) that secure the side panel of the center console as shown in [Figure 177](#).

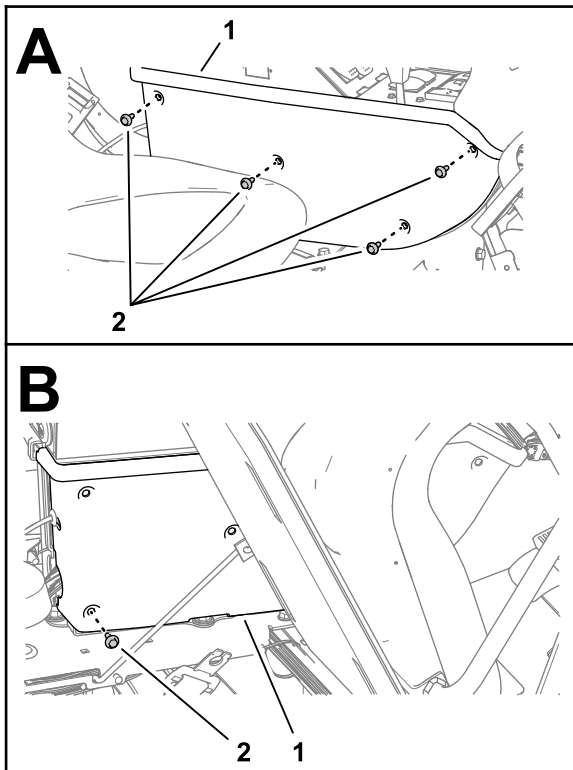

Figure 177

g301406

1. Side panel
2. Flange-head capscrews (1/4 x 3/4 inch)

3. Tilt the passenger seat forward, and remove the lower rear flange-head capscrew ([Figure 177](#)).
4. Remove the side panel from the center console.

### Removing the Terminating Resistor

Forward of the TEC Controller, remove the resistor 75Ω from the 3-socket connector (not labeled) of the machine wire harness ([Figure 178](#)).

**Note:** Retain the resistor for installation in [29 Installing the Adapter Harness and Terminating Resistor \(page 78\)](#).

**Note:** You will install the side panel to the center console when you install the AutoSteer Kit for the Multi Pro 5800 Turf Sprayer with GeoLink; refer to the setup instructions in the AutoSteer kit *Installation Instructions*.

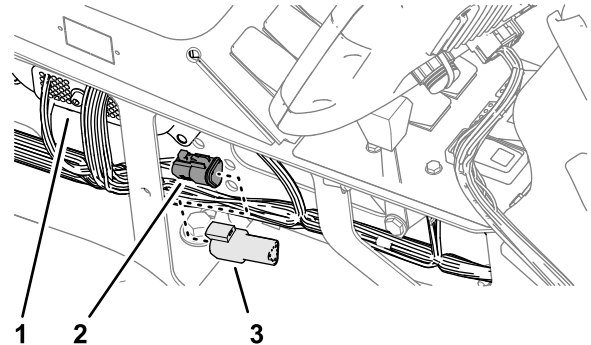

Figure 178

g308955

1. TEC controller
2. 3-socket connector (not labeled—machine wire harness)
3. Resistor 75Ω (3-pin)

### Installing the Console Side Panel

1. Assemble the side panel to the console frame ([Figure 179](#)) with 4 flange-head capscrews (1/4 x 3/4 inch).

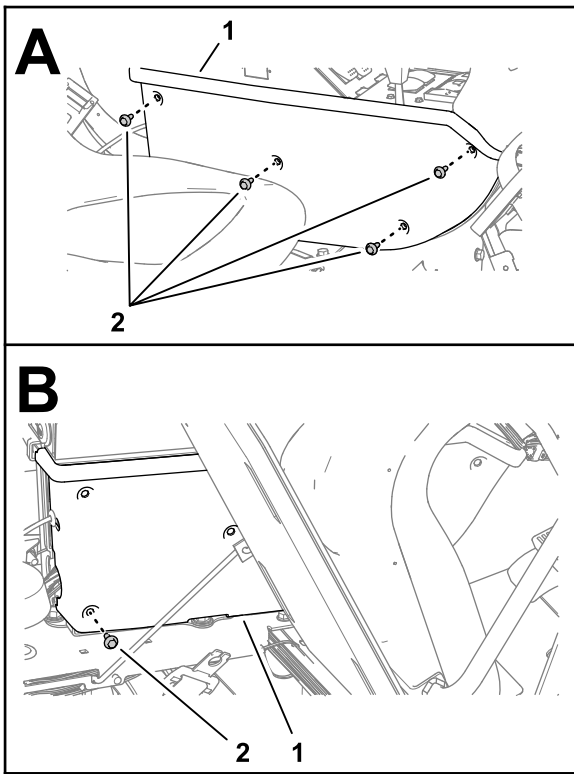

Figure 179

g301406

1. Side panel
2. Flange-head cap screws (1/4 x 3/4 inch)

2. Tilt the seat forward and install the lower rear flange-head cap screw (Figure 179).

# 29

## Installing the Adapter Harness and Terminating Resistor

### Parts needed for this procedure:

1	Adapter harness—13 cm (5 inches)
1	Cable tie

### Procedure

1. At the satellite receiver, remove the ISO bus terminator for the 6-socket connector of the GeoLink harness (Figure 180).

**Note:** You no longer need the ISO bus terminator.

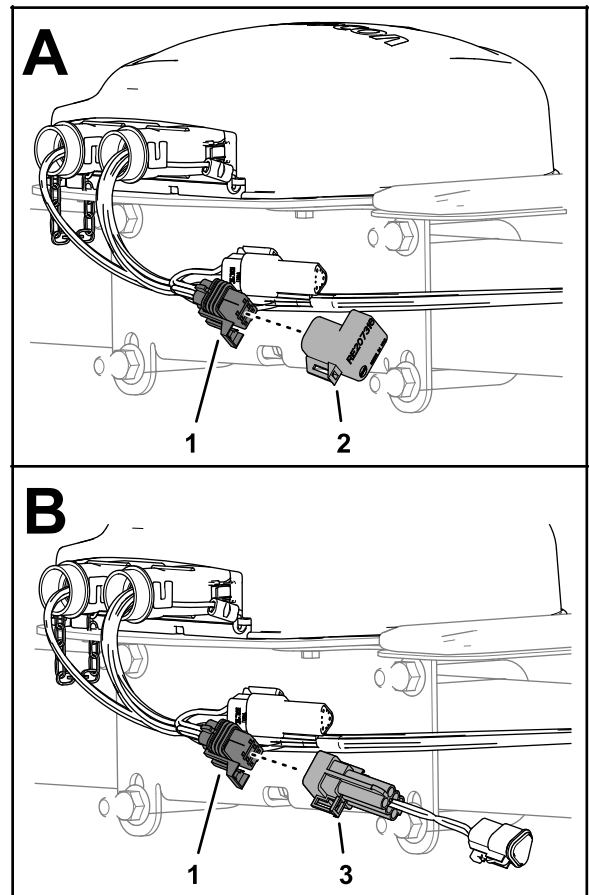

Figure 180

g314512

1. 6-socket connector (GeoLink harness)
2. Terminator (ISO bus)
3. 6-pin connector (adapter harness)

2. Plug the 6-pin connector of the adapter harness—13 cm (5 inches) into the 6-socket connector of the GeoLink harness (Figure 180).
3. Plug the resistor that you removed in Removing the Terminating Resistor (page 77) into the 3-socket connector of the adapter harness (Figure 181).

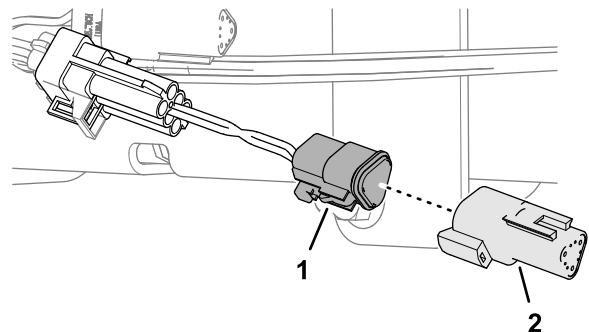

Figure 181

g308954

1. 3-socket connector (adapter harness)
2. Resistor 75Ω (3-pin)

- Secure the adapter harness to the GeoLink harness with a cable tie.

# 30

## Connecting the Wire Harness for the Optional Pivoting Hose-Reel Kit

No Parts Required

### Procedure

- At the back of the machine, locate the wire harness for the electric hose-reel kit at the back of the sprayer tank (A of [Figure 182](#)).

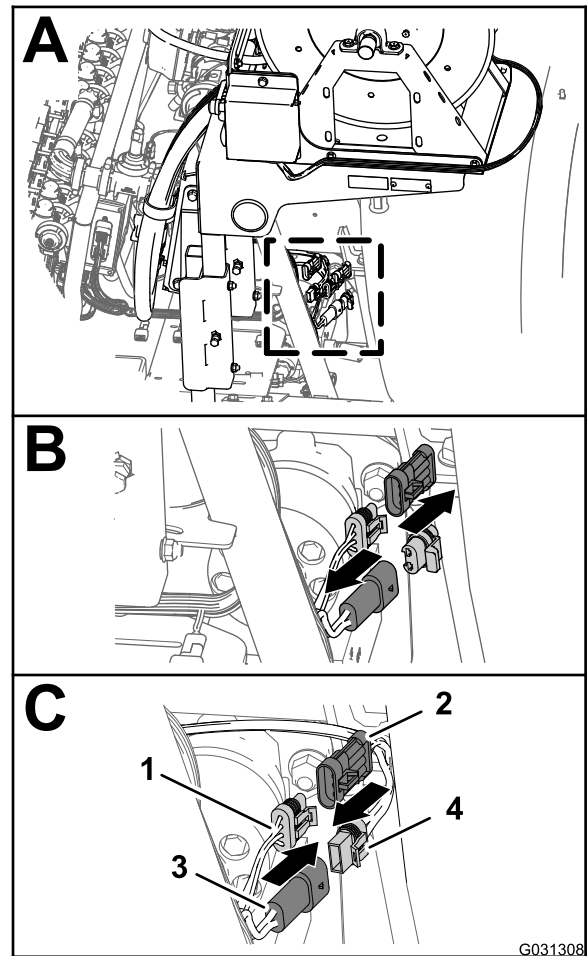

Figure 182

- |   |  |
|---|--|
| 1. 3-socket connector (rear, main harness)      | 3. 2 socket pin (rear, main harness)               |
| 2. 3-pin connector (harness—electric-hose reel) | 4. 2 socket connector (harness—electric-hose reel) |

- Remove the plug from the 2 pin connector of the rear, main harness for the hose-reel power (B in [Figure 182](#)).
- Connect the 2 socket connector of the harness for the electric-hose reel into the 2 pin connector of the rear, main harness (C in [Figure 182](#)).
- Remove the cap from the 3-socket connector of the rear, main harness for the spray harness interconnect (B in [Figure 182](#)).
- Connect the 3 pin connector of the harness for the electric-hose reel into the 3 pin socket of the rear, main harness (C in [Figure 182](#)).

# 31

## Connecting the Compressor Wire Harness for the Optional Foam-Marker Kit

No Parts Required

### Procedure

1. At the end of the 236 cm (93 inch) branch of the wire harness, align the 4-socket connector of the wire harness for the finishing kit with the 4-pin connector of the wire harness from the compressor (Figure 183).

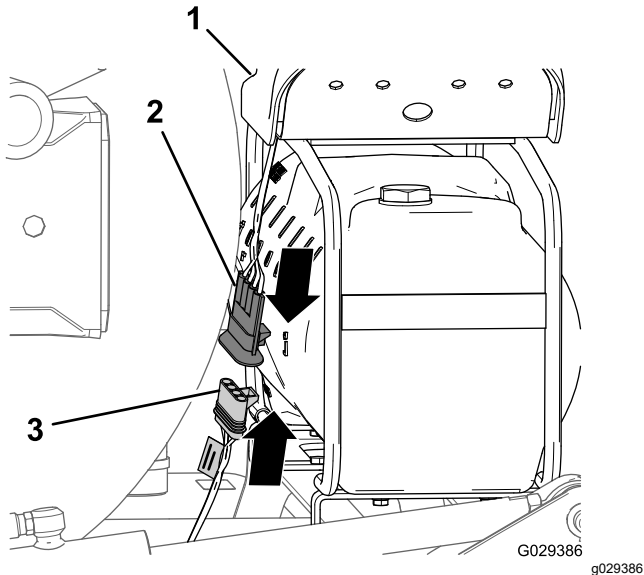

Figure 183

1. Compressor
2. 4-pin connector (wire harness for the compressor)
3. 4-socket connector (wire harness for the finishing kit)

2. Insert the 4-pin connector into the 4-socket connector (Figure 183).

**Note:** Press the connectors together until the latch snaps securely.

# 32

## Connecting the Optional Tank-Rinse Kit

No Parts Required

### Procedure

1. Connect the 6-pin connector of the rinse-pump harness from the 6-socket connector of the rear, main harness (Figure 184).

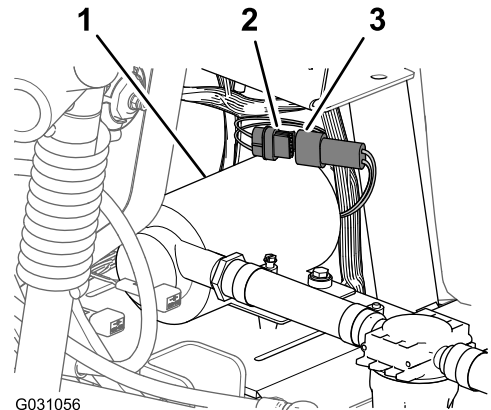

Figure 184

1. Rinse pump
2. 6-socket connector (rear, main harness)
3. 6-pin connector (rinse-pump harness)

2. Align the rinse-pump cover over the saddle plate for the rinse pump (Figure 185).

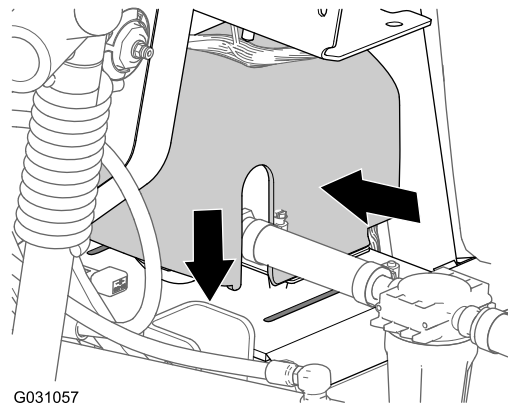

Figure 185

3. Press together the sides of the rinse-pump cover and align the tabs of the cover with the saddle plate (Figure 185).

4. Insert the tabs into the slots and release the sides of the cover ([Figure 185](#)).

# 33

## Completing the Installation of the GeoLink Spray System-Finishing Kit

No Parts Required

### Closing the Seats

Move the prop rods for the seats into the slots and tilt the seats down.

### Assembling the Rear GeoLink Harness, Navigation-Data and Electrical Harness, and Modem Power Harness to the Battery Cables

1. Route the positive terminal (red wire), negative terminal (black wire), and fuses block (50 A) of the rear wire harness up between the battery box and the chassis of the machine ([Figure 186](#)).

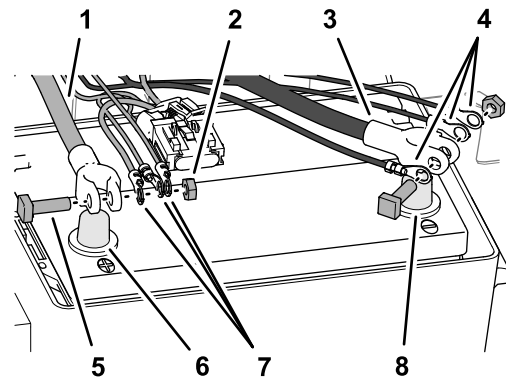

Figure 186

g315081

- |  |  |
|--|--|
| 1. Positive battery cable  | 5. T-bolt  |
| 2. Hex nut   | 6. Battery post (positive)   |
| 3. Negative battery cable  | 7. Positive-ring terminals (black wire)—rear GeoLink wire harness, navigation-data and electrical harness, and modem power harness |
| 4. Negative-ring terminals (black wire)—rear GeoLink wire harness, navigation-data and electrical harness, and modem power harness | 8. Battery post (negative)   |

2. Route the positive terminal (red wire), negative terminal (black wire), and 10 A fuse block of the navigation-electrical harness up between the battery box and the chassis of the machine.
3. Route the ring terminals labeled BATTERY and GROUND of the modem power harness up between the battery box and the chassis of the machine.
4. Remove the T-bolts and hex nuts from the terminals of the positive and negative battery cables ([Figure 186](#)).
5. Assemble a T-bolt through the positive terminal (red wire) of the rear wire harness, the positive terminal of the navigation-electrical harness, modem power harness, and terminal of the positive battery cable ([Figure 186](#)).
6. Loosely secure the terminals and the T-bolt with a hex nut ([Figure 186](#)).
7. Assemble a T-bolt through the negative terminal (black wire) of the rear wire harness, the negative terminal of the navigation-electrical harness, modem power harness, and terminal of the negative battery cable ([Figure 186](#)).
8. Loosely secure the terminals and the T-bolt with a hex nut ([Figure 186](#)).

## Connecting the Battery

1. Connect the positive (red) cable to the positive (+) battery post, and tighten the nut; refer to [Figure 186](#) in [Assembling the Rear GeoLink Harness, Navigation-Data and Electrical Harness, and Modem Power Harness to the Battery Cables](#) (page 81).
2. Connect the negative (black) cable to the negative (-) battery post, and tighten the nut; refer to [Figure 186](#) in [Assembling the Rear GeoLink Harness, Navigation-Data and Electrical Harness, and Modem Power Harness to the Battery Cables](#) (page 81).
3. Slide the insulator boots over both battery posts.
4. Install the battery cover and secure it with the strap; refer to [Figure 1](#) in [Disconnecting the Battery](#) (page 8).



Figure 188

1. Button 5

## Programming the Machine Settings

1. Insert the key into the key switch and rotate the switch to the ON position.  
**Note:** Do not start the engine.
2. At the splash screen, press and hold the button 5 (far right) on the InfoCenter to access the Main Menu screen ([Figure 187](#) or [Figure 188](#)).



Figure 187

1. Button 5

3. On the Main Menu, press button 1 or button 2 until the Settings option is highlighted, and press button 4 to navigate to the Settings menus ([Figure 189](#)).

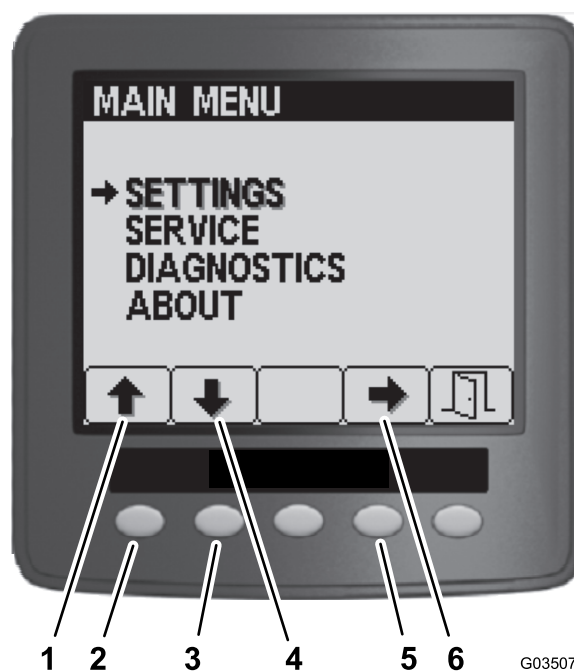

Figure 189

- |               |                 |
|---------------|-----------------|
| 1. Up arrow   | 4. Button 2     |
| 2. Button 1   | 5. Button 4     |
| 3. Down arrow | 6. Select arrow |

4. On the Settings menu, press button 1 or button 2 until the GeoLink option is highlighted, and press button 4 to navigate to the GeoLink menu ([Figure 190](#)).

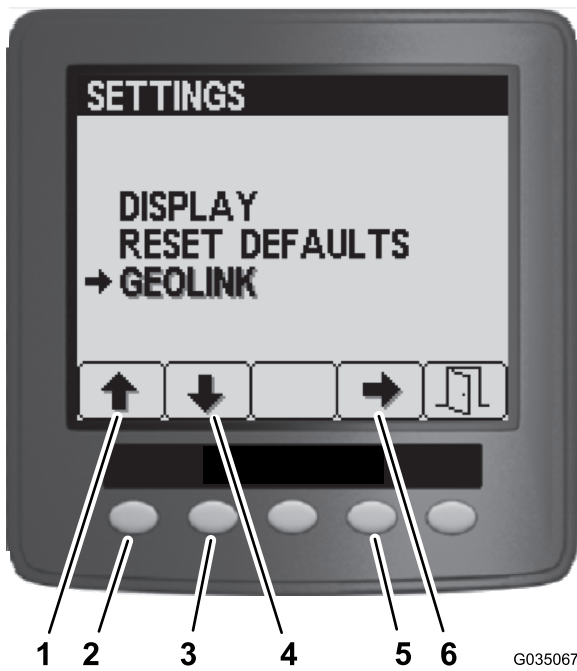

Figure 190

G035067 g035067

- |               |                 |
|---------------|-----------------|
| 1. Up arrow   | 4. Button 2     |
| 2. Button 1   | 5. Button 4     |
| 3. Down arrow | 6. Select arrow |

5. On the GeoLink menu, press button press button 4 to select the Yes option, and press the button 5 to save your settings and exit the menu (Figure 191).



Figure 191

G035068 g035068

- |                 |             |
|-----------------|-------------|
| 1. Button 4     | 3. Button 5 |
| 2. Select arrow | 4. Exit     |

6. Rotate the key switch to the OFF position (Figure 192).



Figure 192

G035108 g035108

7. Rotate the key switch to the ON position (Figure 192).

**Note:** The splash screen for the GeoLink system should display in the InfoCenter.



Figure 193

G035066 g035066

8. Rotate the key switch to the OFF position.

# 34

## Powering the GeoLink Components

No Parts Required

### Procedure

1. Turn the ignition key to the RUN (gasoline) or PREHEAT/RUN (diesel) position.
2. Verify that the following components indicate that each receives power:
  - Control console—displays graphics and text (Figure 194)

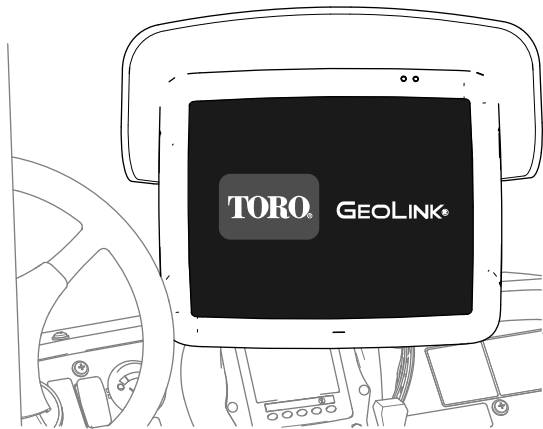

Figure 194

g310669

- Satellite receiver—the PWR indicator illuminates (Figure 195)

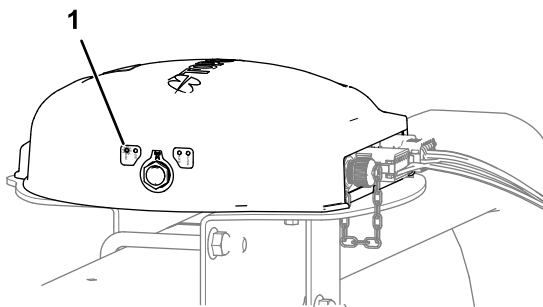

Figure 195

g302922

1. PWR indicator (satellite receiver)

- Modem—the LED indicators illuminate (Figure 196).

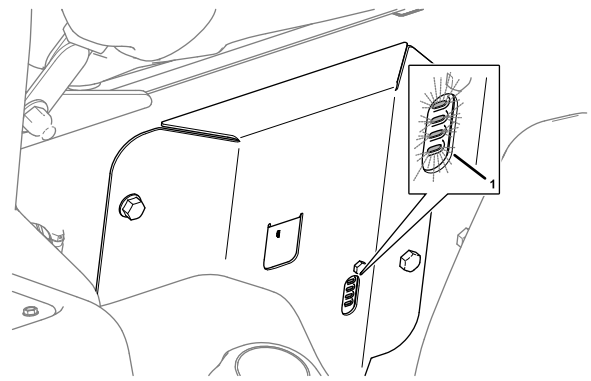

Figure 196

g306264

1. LED Indicators (passenger seat base)

- Automatic section controller—the STATUS indicator illuminates (Figure 197)

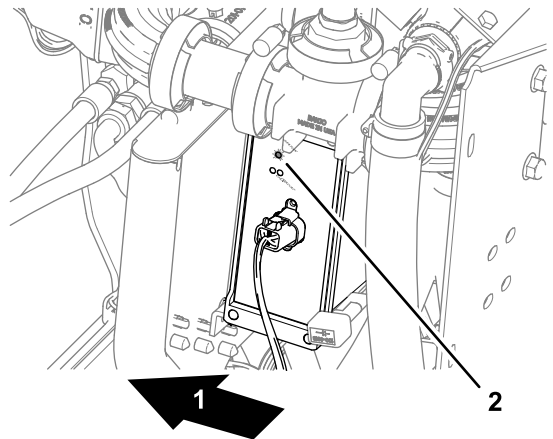

Figure 197

g302923

1. Back of the machine
2. STATUS indicator (automatic section controller)

3. Turn the ignition key to the OFF position.
4. Verify that power is shut off at the following components:
  - Control console
  - Satellite receiver
  - Automatic section controller

# 35

## Verifying the Software Version

No Parts Required

### Procedure

1. Turn the ignition key to the RUN(gasoline) or PREHEAT/RUN (diesel) position.
2. Press the ABOUT (Toro) icon at the upper left corner of the control console (Figure 198).

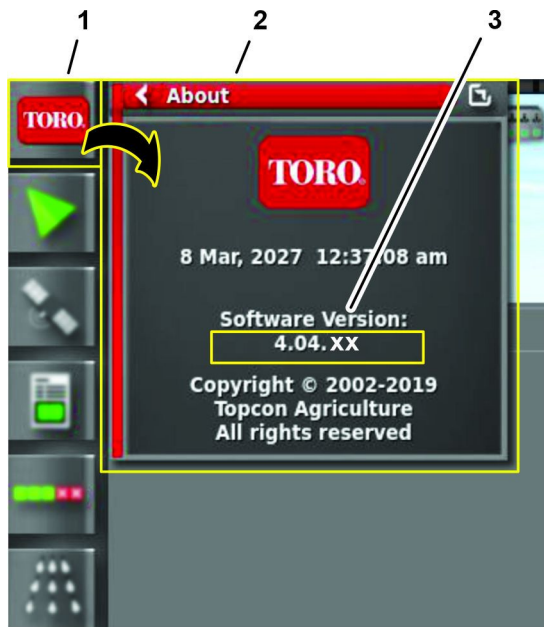

Figure 198

g311338

1. ABOUT (Toro) icon
  2. ABOUT fly-out-window
  3. Software version number (version 4.04 or higher)
- 
3. Compare the software version numbers at the following locations:
    - When used, the cover page of the *Software Guide* for your GeoLink system
    - Displayed in the command console

**Note:** If the software versions differ, contact Toro NSN at 1-844-GEOLINK (1-844-436-5465) or NSNTech@toro.com for customer service.

# 36

## Selecting the Units of Measure

No Parts Required

### Procedure

Select the units of measure; refer to the *Operator's Manual* or *Software Guide* for your GeoLink system.

# 37

## Creating a Field

No Parts Required

### Procedure

Create a new field; refer to the *Operator's Manual* or *Software Guide* for your GeoLink system.

# 38

## Creating a New Product and Application Rate

No Parts Required

### Procedure

Create a new product and application rate entry; refer to the *Operator's Manual* or *Software Guide* for your GeoLink system.

# 39

## Creating a Spray Job

No Parts Required

### Procedure

1. Press the Job Menu and press the CREATE NEW JOB icon (Figure 199).

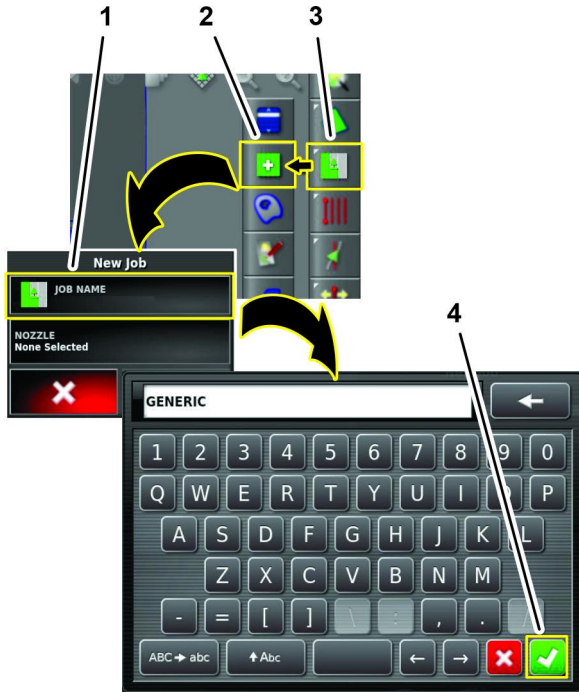

Figure 199

g304037

1. JOB NAME icon
2. CREATE NEW JOB icon
3. JOB MENU icon
4. Confirm icon

2. Use on-screen keyboard to type a name for the generic job, and press the confirm icon (Figure 199).
3. In the new job dialog box, press the NOZZLE icon (Figure 200).



Figure 200

g304039

1. NOZZLE icon
2. Nozzle selection list icons
3. Confirm icon

4. In the nozzle selection list, press any nozzle icon, and press the confirm icon (Figure 200).
5. In the new job dialog box, press the confirm icon (Figure 201).



Figure 201

g304038

1. Confirm icon

# 40

## Checking the Spray System

No Parts Required

### Procedure

1. Engage the parking brake.
2. Add 200 L (50 US gallon) of water into the spray tank; refer to the *Operator's Manual* for your machine.
3. Start the engine and set the engine speed to fast.
4. On the GeoLink control console, press the SPRAY RATE CONTROLLER icon (Figure 202).

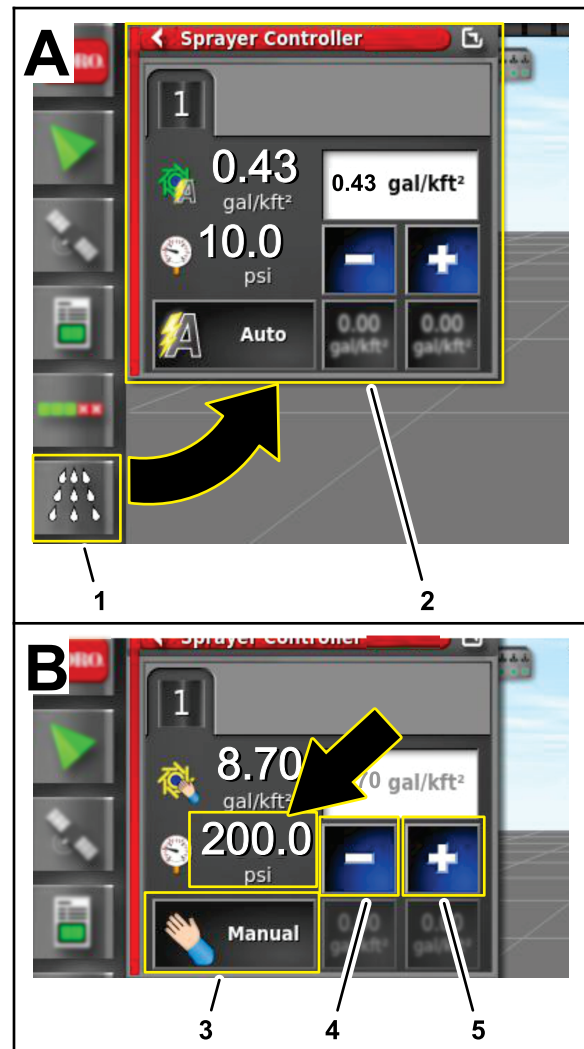

Figure 202

g303612

1. SPRAY RATE CONTROLLER icon
2. Dialog box (spray rate controller)
3. RATE CONTROL MODE icon (manual mode)
4. Decrement icon (-)
5. Increment icon (+)

5. In the spray rate controller dialog box, press the RATE CONTROL MODE icon until manual mode displays (Figure 202).
6. Use the decrement icon (-) or increment icon (+) to adjust the spray system pressure (Figure 202) to 13.75 bar (200 psi).
7. On the machine, press the master-section switch to the ON position (Figure 203).

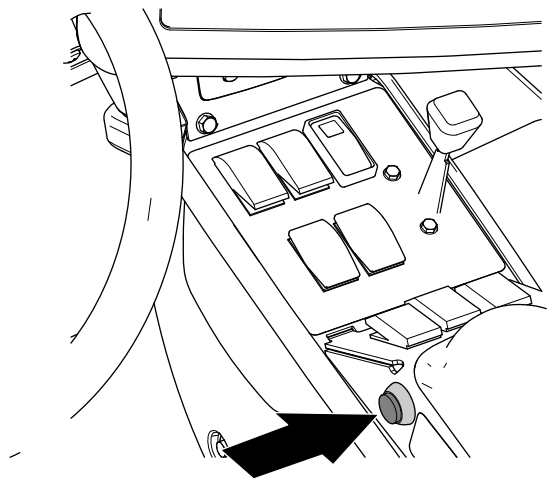

Figure 203

g205127

- On the GeoLink control console, press the MASTER SWITCH icon (Figure 204) to the ON (green).

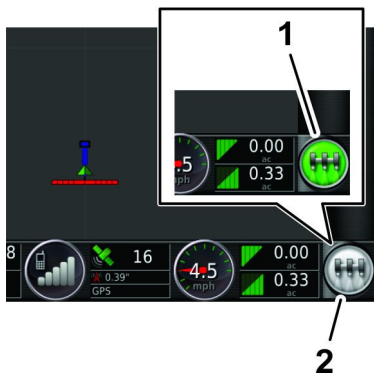

Figure 204

g203807

- Green MASTER SWITCH icon (system ready, sprayer controller on)
- White MASTER SWITCH icon (standby)

- Check all sprayer fittings and components for leaks.

**Note:** If you find any leaks, shut off the engine and repair the fitting or component.

# 41

## Balancing the Agitation Bypass Valve

No Parts Required

### Checking System and Agitation Bypass Pressure

- Engage the parking brake, and start the engine.
 

**Note:** Allow the engine and hydraulic system to warm for 10 minutes.
- Ensure that the master section switch to the OFF position.
- Set the spray-pump switch and the tank agitation switch to the ON position.
- Set the left, center, and right section switches to the ON position.
- Set the engine speed to fast.
- On the GeoLink control console, press the SPRAY RATE CONTROLLER icon.
- In the spray rate controller dialog box, press the RATE CONTROL MODE icon until manual mode displays (Figure 205).

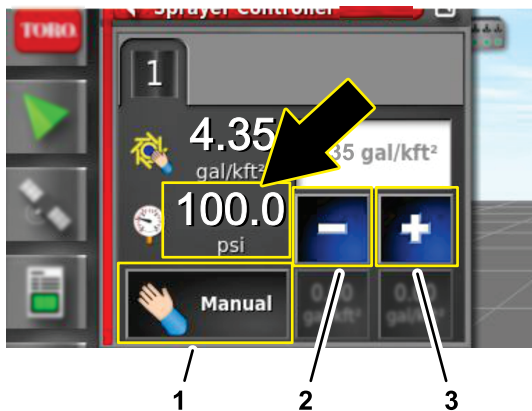

Figure 205

g303643

- RATE CONTROL MODE icon
- Decrement icon (-)
- Increment icon (+)

- Press the decrement icon (-) or increment icon (+) to adjust the spray system pressure (Figure 205) to 6.9 bar (100 psi).
- On the machine, set the tank agitation switch to the OFF position.

- Observe the spray system pressure. If the spray system pressure is 6.9 bar (100 psi), the agitation valve is correctly adjusted.

If the spray system pressure changed, adjust the agitation bypass valve; refer to [Adjusting the Agitation Bypass Valve \(page 89\)](#).

## Adjusting the Agitation Bypass Valve

- With the tank agitation switch in the OFF position, walk to the back of the machine and locate the agitation bypass valve.

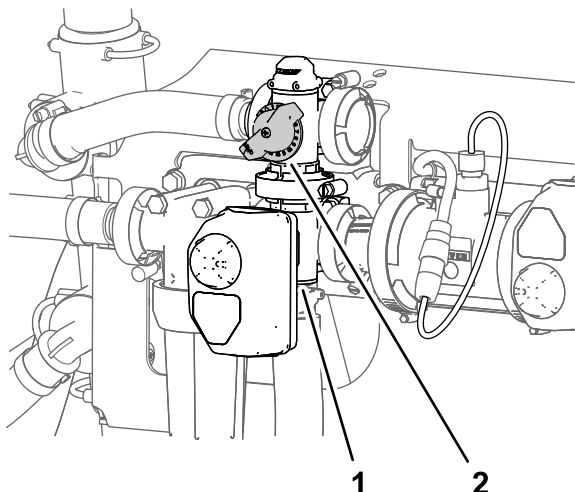

Figure 206

g191362

- Actuator (agitation valve)
- Agitation-bypass valve

- Adjust the agitation-bypass valve ([Figure 206](#)) until the gauge indicates 689 kPa (100 psi) sprayer system pressure.
- Set the tank agitation switch to the ON position and observe the spray system pressure.

**Note:** If the spray system-pressure gauge indicates greater than or less than 6.9 bar (100 psi), repeat steps 1 and 2.

- Set the tank agitation switch to the OFF position and observe the spray system pressure.

**Note:** If the spray system-pressure gauge indicates greater than or less than 6.9 bar (100 psi), repeat steps 1 and 2.

# 42

## Performing a Flow Meter Calibration

No Parts Required

### Procedure

Calibrate the flow meter; refer to the *Operator's Manual* or *Software Guide* for your GeoLink system.

# 43

## Verifying the Cellular Status

No Parts Required

### Procedure

- Press the SYSTEM INFORMATION icon, and then swipe the FULL SCREEN icon in the upper right corner of the system information window ([Figure 207](#)).

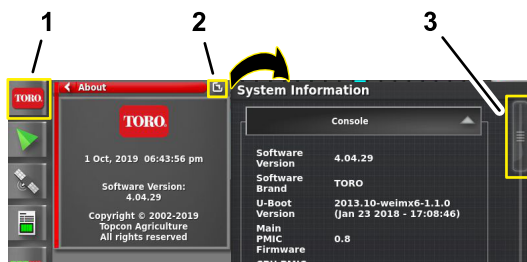

Figure 207

g305245

- SYSTEM INFORMATION
- FULL SCREEN icon
- Scroll bar

- In the system information screen, use the scroll bar to navigate to the CL55 icon ([Figure 208](#)).

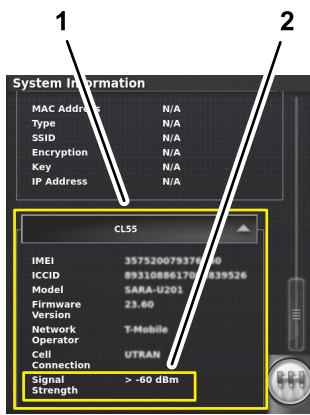

Figure 208

g305244

1. CL55 icon
2. Signal strength information

3. Press the CL55 icon to display the signal strength information.(Figure 208), and verify that the modem signal strength is between -60 dBm and -99 dBm.

**Note:** If the modem signal is equal to or less than -100 dBm, contact your authorized Toro distributor, Toro NSN at 1-844-GEOLINK (1-844-436-5465), or NSNTech@toro.com for customer service.

4. Swipe the FULL SCREEN icon to minimize the system information screen.

# 44

## Performing a Compass Calibration

### At the Distributor's Location

No Parts Required

### Procedure

Perform a compass calibration at the distributor's location; refer to Calibrating the Compass in the *Operator's Manual* or *Software Guide* for your GeoLink system.

# 45

## Clearing NVRAM

### At the Customer Location

No Parts Required

### Changing the Setup Screen for Dealer Access

**Important:** You must erase the nonvolatile RAM at the customer location.

1. Contact Toro NSN at 1-844-GEOLINK (1-844-436-5465) or NSNTech@toro.com for customer service to request the dealer access level password.
2. Rotate the ignition key to the ON position.
3. Press the SETUP icon on the main screen (Figure 209).

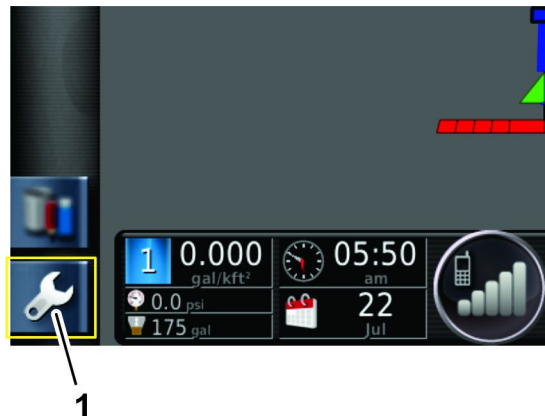

Figure 209

g204035

1. SETUP icon

4. In the setup screen, press the USER icon and the ACCESS LEVEL icon(Figure 210).



Figure 210

g309146

1. PASSWORD icon
2. USER icon
3. ACCESS LEVEL icon

5. Press the PASSWORD icon (Figure 210).
6. Use the on-screen keyboard to enter the password that you received in step 1, and press the confirm icon (Figure 211).

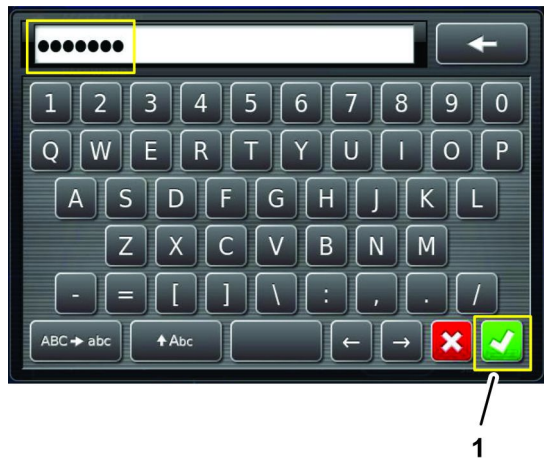

Figure 211

g309149

1. Confirm icon

**Note:** The user access level screen displays the DEALER icon (Figure 212).

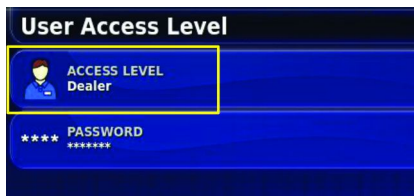

Figure 212

g309223

## Erasing the Nonvolatile RAM

1. In the setup screen, press the SYSTEM icon, GPS icon, and ADVANCED CONFIGURATION icon (Figure 213).

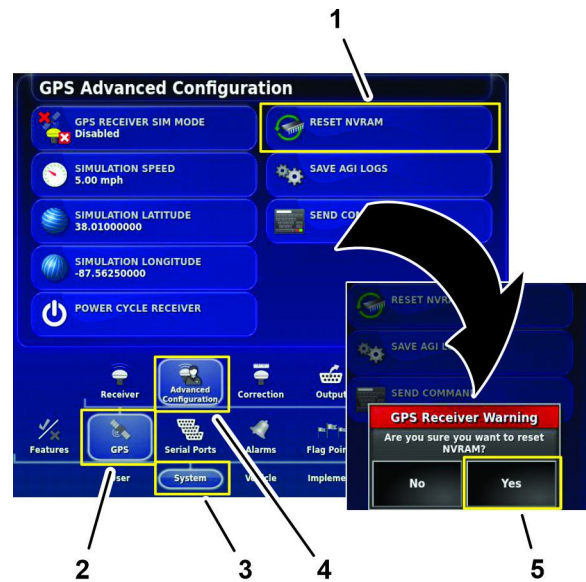

Figure 213

g309147

1. RESET NVRAM icon
2. GPS icon
3. SYSTEM icon
4. ADVANCED CONFIGURATION icon
5. YES icon

2. In the GPS Advanced Configuration screen, press the RESET NVRAM icon (Figure 213).
3. In the GPS receive warning dialog box, press the YES icon (Figure 213).

**Note:** The receiver disconnected warning (Figure 214) displays briefly.

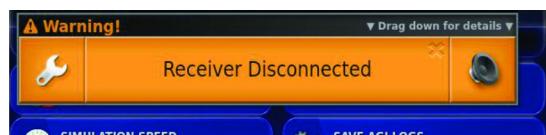
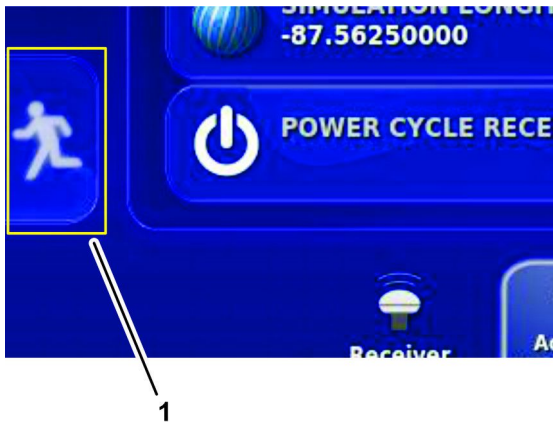

Figure 214

g309150

4. Wait 2 minutes for the satellite receiver and modem startup.
5. Press the EXIT SETUP icon



**Figure 215**

g309148

1. EXIT SETUP icon

6. Rotate the ignition switch to the OFF position.

# 46

## Performing a Compass Calibration

### At the Customer Location

**No Parts Required**

### Procedure

Perform a compass calibration at the customer's location; refer to *Calibrating the Compass* in the *Operator's Manual* or *Software Guide* for your GeoLink system.

# Notes:

**Notes:**

## EEA/UK Privacy Notice

### **Toro's Use of Your Personal Information**

The Toro Company ("Toro") respects your privacy. When you purchase our products, we may collect certain personal information about you, either directly from you or through your local Toro company or dealer. Toro uses this information to fulfil contractual obligations - such as to register your warranty, process your warranty claim or to contact you in the event of a product recall - and for legitimate business purposes - such as to gauge customer satisfaction, improve our products or provide you with product information which may be of interest. Toro may share your information with our subsidiaries, affiliates, dealers or other business partners in connection these activities. We may also disclose personal information when required by law or in connection with the sale, purchase or merger of a business. We will never sell your personal information to any other company for marketing purposes.

### **Retention of your Personal Information**

Toro will keep your personal information as long as it is relevant for the above purposes and in accordance with legal requirements. For more information about applicable retention periods please contact [legal@toro.com](mailto:legal@toro.com).

### **Toro's Commitment to Security**

Your personal information may be processed in the US or another country which may have less strict data protection laws than your country of residence. Whenever we transfer your information outside of your country of residence, we will take legally required steps to ensure that appropriate safeguards are in place to protect your information and to make sure it is treated securely.

### **Access and Correction**

You may have the right to correct or review your personal data, or object to or restrict the processing of your data. To do so, please contact us by email at [legal@toro.com](mailto:legal@toro.com). If you have concerns about the way in which Toro has handled your information, we encourage you to raise this directly with us. Please note that European residents have the right to complain to your Data Protection Authority.



# The Toro Warranty

Two-Year or 1,500 Hours Limited Warranty

## Conditions and Products Covered

The Toro Company and its affiliate, Toro Warranty Company, pursuant to an agreement between them, jointly warrant your Toro Commercial product ("Product") to be free from defects in materials or workmanship for 2 years or 1,500 operational hours\*, whichever occurs first. This warranty is applicable to all products with the exception of Aerators (refer to separate warranty statements for these products). Where a warrantable condition exists, we will repair the Product at no cost to you including diagnostics, labor, parts, and transportation. This warranty begins on the date the Product is delivered to the original retail purchaser.

\* Product equipped with an hour meter.

## Instructions for Obtaining Warranty Service

You are responsible for notifying the Commercial Products Distributor or Authorized Commercial Products Dealer from whom you purchased the Product as soon as you believe a warrantable condition exists. If you need help locating a Commercial Products Distributor or Authorized Dealer, or if you have questions regarding your warranty rights or responsibilities, you may contact us at:

Toro Commercial Products Service Department  
Toro Warranty Company  
8111 Lyndale Avenue South  
Bloomington, MN 55420-1196  
952-888-8801 or 800-952-2740  
E-mail: commercial.warranty@toro.com

## Owner Responsibilities

As the product owner, you are responsible for required maintenance and adjustments stated in your *Operator's Manual*. Repairs for product issues caused by failure to perform required maintenance and adjustments are not covered under this warranty.

## Items and Conditions Not Covered

Not all product failures or malfunctions that occur during the warranty period are defects in materials or workmanship. This warranty does not cover the following:

- Product failures which result from the use of non-Toro replacement parts, or from installation and use of add-on, or modified non-Toro branded accessories and products.
- Product failures which result from failure to perform recommended maintenance and/or adjustments.
- Product failures which result from operating the Product in an abusive, negligent, or reckless manner.
- Parts consumed through use that are not defective. Examples of parts which are consumed, or used up, during normal Product operation include, but are not limited to, brake pads and linings, clutch linings, blades, reels, rollers and bearings (sealed or greasable), bed knives, spark plugs, castor wheels and bearings, tires, filters, belts, and certain sprayer components such as diaphragms, nozzles, flow meters, and check valves.
- Failures caused by outside influence, including, but not limited to, weather, storage practices, contamination, use of unapproved fuels, coolants, lubricants, additives, fertilizers, water, or chemicals.
- Failure or performance issues due to the use of fuels (e.g. gasoline, diesel, or biodiesel) that do not conform to their respective industry standards.
- Normal noise, vibration, wear and tear, and deterioration. Normal "wear and tear" includes, but is not limited to, damage to seats due to wear or abrasion, worn painted surfaces, scratched decals or windows.

## Countries Other than the United States or Canada

Customers who have purchased Toro products exported from the United States or Canada should contact their Toro Distributor (Dealer) to obtain guarantee policies for your country, province, or state. If for any reason you are dissatisfied with your Distributor's service or have difficulty obtaining guarantee information, contact your Authorized Toro Service Center.

## Parts

Parts scheduled for replacement as required maintenance are warranted for the period of time up to the scheduled replacement time for that part. Parts replaced under this warranty are covered for the duration of the original product warranty and become the property of Toro. Toro will make the final decision whether to repair any existing part or assembly or replace it. Toro may use remanufactured parts for warranty repairs.

## Deep Cycle and Lithium-Ion Battery Warranty

Deep cycle and Lithium-Ion batteries have a specified total number of kilowatt-hours they can deliver during their lifetime. Operating, recharging, and maintenance techniques can extend or reduce total battery life. As the batteries in this product are consumed, the amount of useful work between charging intervals will slowly decrease until the battery is completely worn out. Replacement of worn out batteries, due to normal consumption, is the responsibility of the product owner. Note: (Lithium-Ion battery only): Refer to the battery warranty for additional information.

## Lifetime Crankshaft Warranty (ProStripe 02657 Model Only)

The Prostripe which is fitted with a genuine Toro Friction Disc and Crank-Safe Blade Brake Clutch (integrated Blade Brake Clutch (BBC) + Friction Disc assembly) as original equipment and used by the original purchaser in accordance with recommended operating and maintenance procedures, are covered by a Lifetime Warranty against engine crankshaft bending. Machines fitted with friction washers, Blade Brake Clutch (BBC) units and other such devices are not covered by the Lifetime Crankshaft Warranty.

## Maintenance is at Owner's Expense

Engine tune-up, lubrication, cleaning and polishing, replacement of filters, coolant, and completing recommended maintenance are some of the normal services Toro products require that are at the owner's expense.

## General Conditions

Repair by an Authorized Toro Distributor or Dealer is your sole remedy under this warranty.

**Neither The Toro Company nor Toro Warranty Company is liable for indirect, incidental or consequential damages in connection with the use of the Toro Products covered by this warranty, including any cost or expense of providing substitute equipment or service during reasonable periods of malfunction or non-use pending completion of repairs under this warranty. Except for the Emissions warranty referenced below, if applicable, there is no other express warranty. All implied warranties of merchantability and fitness for use are limited to the duration of this express warranty.**

Some states do not allow exclusions of incidental or consequential damages, or limitations on how long an implied warranty lasts, so the above exclusions and limitations may not apply to you. This warranty gives you specific legal rights, and you may also have other rights which vary from state to state.

## Note Regarding Emissions Warranty

The Emissions Control System on your Product may be covered by a separate warranty meeting requirements established by the U.S. Environmental Protection Agency (EPA) and/or the California Air Resources Board (CARB). The hour limitations set forth above do not apply to the Emissions Control System Warranty. Refer to the Engine Emission Control Warranty Statement supplied with your product or contained in the engine manufacturer's documentation.