



MODEL NO. 30799 – 210000001 & UP

OPERATOR'S
MANUAL

72" Flex Deck™ Side Discharge Mower

FOR GROUNDMASTER® 300 SERIES TRACTION UNITS

To ensure maximum safety, optimum performance, and to gain knowledge of the product, it is essential that you or any other operator of the machine read and understand the contents of this manual before the engine is ever started. Pay particular attention to the SAFETY INSTRUCTIONS highlighted by this symbol —



The safety alert symbol means CAUTION, WARNING or DANGER — personal safety instruction. Failure to comply with the instruction may result in personal injury.



FOREWORD

The 72" Flex Deck Side Discharge Mower has advanced concepts in engineering, design and safety; and if maintained properly, will give excellent service.

Since this is a high-quality product, Toro is concerned about the future use of the machine and safety of the user. Therefore, read this manual to familiarize yourself with proper set-up, operation and maintenance instructions. The major sections of the manual are:

- | | | |
|------------------------|---------------------|----------------|
| 1. Safety Instructions | 3. Before Operating | 5. Lubrication |
| 2. Setup Instructions | 4. Operation | 6. Maintenance |

Certain information in this manual is emphasized. DANGER, WARNING and CAUTION identify personal safety related information. IMPORTANT identifies mechanical information demanding special attention. Be sure to read this directive because it deals with the possibility of damaging a part or parts of the machine. NOTE identifies general information worthy of special attention.

TABLE OF CONTENTS

	Page		Page
SAFETY AND INSTRUCTION DECALS	3	Adjust Skid	12
SPECIFICATIONS	4	Adjust Rollers	12
LOOSE PARTS	5	OPERATING INSTRUCTIONS	13
SETUP INSTRUCTIONS	6	Grass Deflector	13
Mount Hose Clamp	6	Operating Tips	13
Grass Deflector	6	LUBRICATION	14
Mount Rear Castor Wheels	6	Grease Bearings, Bushings and Gear Box ...	14
Connect Right-Hand Push Arm to Cutting Unit	6	MAINTENANCE	15
Connect Left-Hand Push Arm to Cutting Unit ..	7	Trouble Shooting	15
Mount Front Lift Arm	8	Separating Cutting Unit from Traction Unit ...	16
Mount Rear Lift Bracket	8	Mounting Cutting Unit to Traction Unit	16
Install Drive Shaft to Traction Unit	9	Adjusting Drive Belts	16
Install Lift Chains	9	Replacing Drive Belts	17
Adjust Counterbalance Spring	9	Servicing Front Bushings in Castor Arms	17
Grease Cutting Unit	9	Servicing Castor Wheels and Bearings	17
Install Rear Weight	10	Replacing Grass Deflector	18
BEFORE OPERATING	11	Removing Cutter Blade	18
Check Lubricant in Gear Box	11	Inspecting and Sharpening Blade	19
Adjusting Height-of-Cut	11	Correcting Cutting Unit Mismatch	20
Check Tire Pressure	12	IDENTIFICATION AND ORDERING	20

SAFETY AND INSTRUCTION DECALS

The following decals are installed on the machine. If any become damaged or illegible, replace it. The decal part number is listed below and in your parts catalog. Replacements can be ordered from your Authorized Toro Distributor.



93-3709



100-6582

1. Warning—Cutting hazard of hands



93-6696

1. Warning—part is spring loaded. Read the operator's manual.

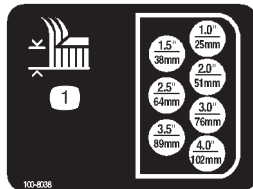

100-8038

1. Height-of-cut setting for rear deck chain

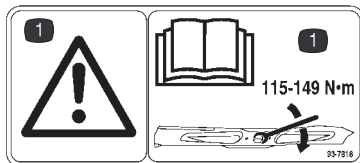

93-7818

1. Warning—torque the blade bolt to 115–149 N•m. Read the operator's manual for further instructions.

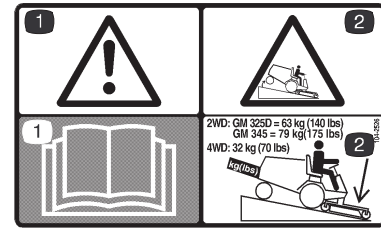

104-2526

1. Warning—read the operator's manual.
2. Lower cutting unit before going down hills. When operating the Groundsmaster 325-D or 345 two-wheel drive or four-wheel drive, rear weight must be added to the machine.



54-9220

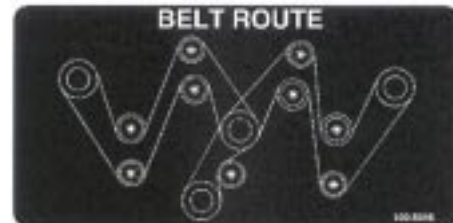

100-8046

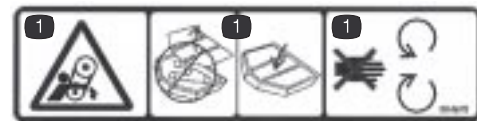

100-6578

1. Entanglement hazard—keep belt covers in place. Stay away from moving parts.

SAFETY AND INSTRUCTION DECALS



93-6697

1. Change the gearbox oil every 50 hours. Read the operator's manual for further instructions.

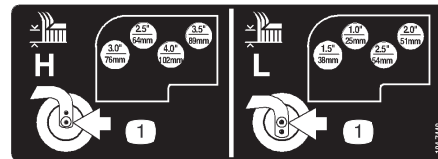

104-7449

1. Height-of-cut setting for rear castor wheels on right chamber



93-7824

1. Thrown object hazard—keep bystanders away.
2. Thrown object hazard from mower—keep the deflector in place.
3. Cutting/dismemberment hazard of hands or feet—stay away from rotating blades and moving parts.

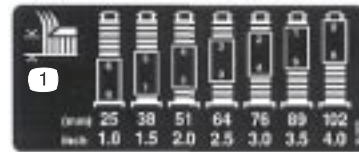

93-3035

1. Height-of-cut setting for front castor wheels.

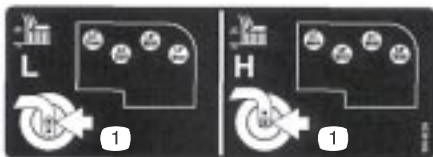

100-8039

1. Height-of-cut setting for rear castor wheels on left chamber

SPECIFICATIONS

Width of Cut: 72"

Configuration: Three blades, one blade center section, and two 1 blade floating wings. Wings flex up and down 12 degrees in a single plane perpendicular to from center section.

Height of Cut: Adjustable front and rear, in .50 inch increments from 1 to 4 inches.

Construction: 12-gauge steel, 5.25 inches deep, welded construction and reinforced with 10-gauge steel channels.

Blades: Three 25 inch long, .25 inch thick, heat treated steel blades.

Cutter Drive: PTO driven gearbox with 1.26—1 spiral bevel gears. One "B" section belt on center section. One "B" section belt on each wing. Center section tensioned through spring loaded idler. Wings tensioned through adjustable fixed idler.

Spindles: Cast iron housing, 1-1/4 inch dia shaft with welded blade retainer. Turning on two greaseable tapered roller bearings. A positive splined connection attaches pulley to spindle shaft.

Castor Wheels: Front: Four 8 inch pneumatic wheels with greaseable roller bearings. Rear: Two 8 inch pneumatic wheels with greaseable roller bearings (one on each wing). Center section suspended from push arms.

Anti Scalp: Anti-scalp cup (11 inch diameter) located on each blade. One anti-scalp roller on rear of center section. Adjustable skid on right wing.

Trimability: 34" uncut circle, 25" uncut circle with use of individual wheel brakes.

Tip Speed: 15,000 ft./min. @ 3200 engine RPM.

Discharge: Left-hand, side discharge (recycler kit available).

Safety Certification: To meet, proposed ANSI B71.4—1990 and 1999, safety specifications for power lawn mowers, and CE requirements.

Belt Covers: Steel covers bolted down, meets CE requirements.

Sound Levels: 90 dBa @ operator ear.

Weight: 550 lb.

Width: 83-1/2 in.

SPECIFICATIONS

Options:

High Lift Blade:	Part No. 23-2410
Height of cut spacers 1/4"	Part No. 54-8810
Foam Filled 8" Tire	Part No. 93-5974

Specifications and design subject to change without notice.

LOOSE PARTS

NOTE: Use this chart as a checklist to ensure that all parts have been received. Without these parts, total set-up cannot be completed.

Description	Qty.	Use
Hose clamp	1	Install hose clamp
Hose bracket	2	
Capscrew, 1/4 x 1 in.	2	
Nut	2	
Push arm adapter	1	Install right push arm adapter
Push arm plate	1	
Capscrew, 3/8 x 2-3/4 in.	4	
Flat washer	4	
Nut	4	
Front lift arm	1	
Locknut	2	
Capscrew, 3/8 x 3 in.	2	
Rear lift bracket	1	Install rear lift support
Square U-bolt	1	
U-bolt	1	
Height-of-cut chain	1	
Clevis pin	1	
Hairpin	1	
Nut	6	
Capscrew, 3/8 x 7/8 in.	4	Secure covers for CE
Roll pin	1	Install drive shaft
Danger decal	1	Place over 54-9220 on deflector for CE.
Parts catalog	1	
Operator's manual	1	Read before operating the machine.
Registration card	1	Fill out and return to Toro.

SETUP INSTRUCTIONS

MOUNT HOSE CLAMP (Fig. 1 –2)

1. Using dimensions shown in figure 1, locate, mark and drill (2) .28 in. dia. holes in traction unit platform. Use caution when drilling as there are hoses and cables under platform.

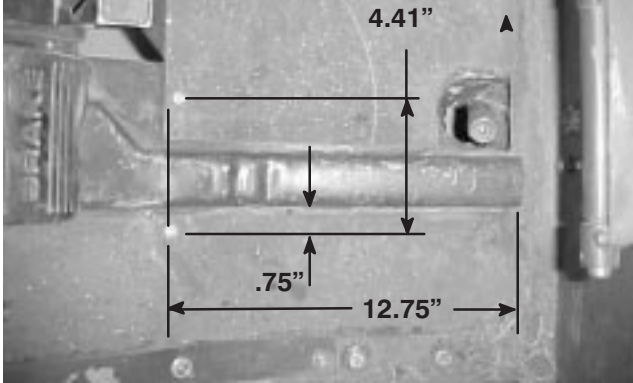

Figure 1

2. Secure hoses to under side of platform with clamp, (2) brackets, capscrews and nuts. Position brackets to fit contour of hoses and platform.

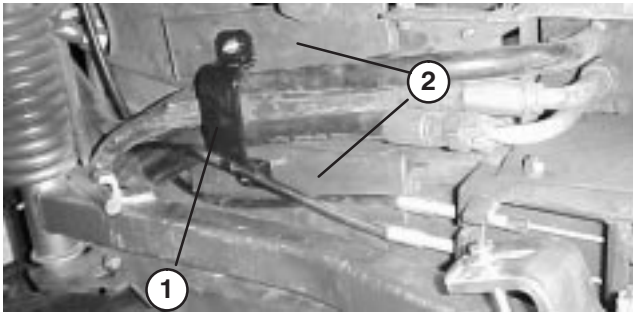

Figure 2

1. Clamp
2. Bracket (2)

GRASS DEFLECTOR (Fig. 3)

3. Remove shipping bands allowing deflector to be lowered.



WARNING

Deflector is spring loaded in the down position and will rotate downward, if not restrained, when band is cut. If done improperly, personal injury may occur.

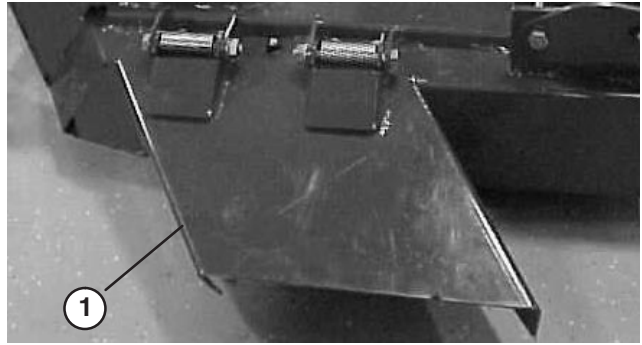

Figure 3

1. grass Deflector

MOUNT REAR CASTOR WHEELS (Fig. 4)

The rear castor wheels are shipped secured upside down to deck brackets.

1. Remove capscrew and locknut securing front of rear castor pivot to deck bracket.

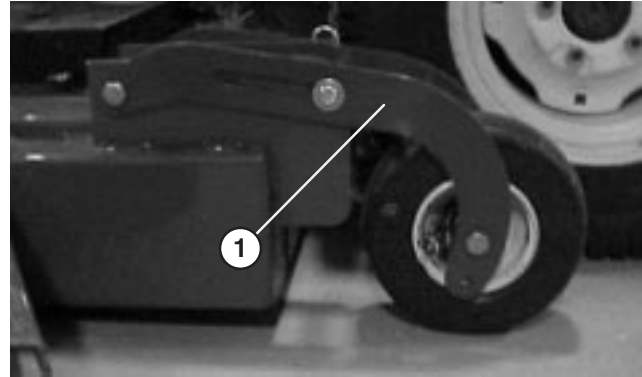

Figure 4

1. Rear castor pivot arm

2. Turn pivot right side up and secure front of castor pivot arm to front of deck bracket with capscrew and locknut removed.

3. Align the pivot arm holes with selected height-of-cut bracket holes in the deck frame, install clevis pin and secure with hairpin cotter.

4. Repeat procedure on other castor wheel assembly.

CONNECT RIGHT-HAND PUSH ARM TO CUTTING UNIT (Fig. 5– 6)

Note: Ball joints are shipped with traction unit.

1. Thread a jam nut fully onto ball joint.
2. Thread ball joint into push arm adapter until a dimension of 2-3/8 in. from end of adapter to center of ball joint is attained. Do not tighten jam nut.

SETUP INSTRUCTIONS

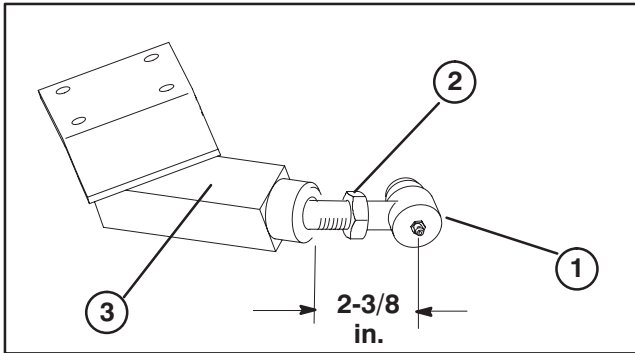

Figure 5

1. Ball joint
2. Jam nut
3. Push arm adapter

3. Remove 2 flange head capscrews and flange nuts securing right hand ball joint mount to castor arm. Remove ball joint mount from castor arm.

4. Install ball joint to right hand ball joint mount with a castle nut and cotter pin (Fig. 6).

5. Loosely mount push arm adapter to bottom of right push arm with a push arm bracket and (4) capscrews, flat washers, and flange head locknuts. Push arm adapter to be positioned approximately 1 in. (25 mm) from end of square tube on right push arm (Fig. 6).

Note: Push arm plate to be positioned on top of push arm. Push arm adapter is mounted to under side of push arm.

6. Move cutting unit into position in front of traction unit.

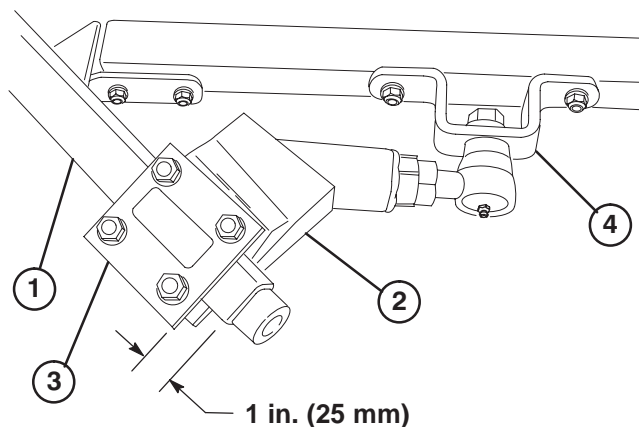

Figure 6

1. Right-Hand Push Arm
2. Push arm adapter
3. Push arm bracket
4. Ball Joint Mount



WARNING

Since the right hand push arm is spring loaded to about 100 pounds, a helper is needed to push the arm down. Sudden release of the push arm could cause injury.

7. Have a helper carefully push down on the right push arm until holes in ball joint mount line up with holes in castor arm. Immediately slide a 4 x 4 in. block of wood between top of push arm and underside of chassis.

8. Secure ball joint mount to castor arm with 2 flange head capscrews and flange nuts previously removed.

Note: Capscrew heads to be positioned on inside of castor arm.

9. Tighten large jam nut securing ball joint to push arm adapter (Fig. 5). When tightening jam nut, hold ball joint straight to permit proper oscillation during raising and lowering of cutting unit. Carefully remove wood block holding push arm down.

CONNECT LEFT-HAND PUSH ARM TO CUTTING UNIT (Fig. 7– 8)



WARNING

Since the left hand push arm is spring loaded to about 150 pounds, a helper is needed to push the arm down. Sudden release of the push arm could cause injury.

1. Thread a jam nut fully onto ball joint.

2. Thread ball joint into left push arm until a dimension of 2-3/8 in. from end of push arm to center of ball joint is attained. Do not tighten jam nut.

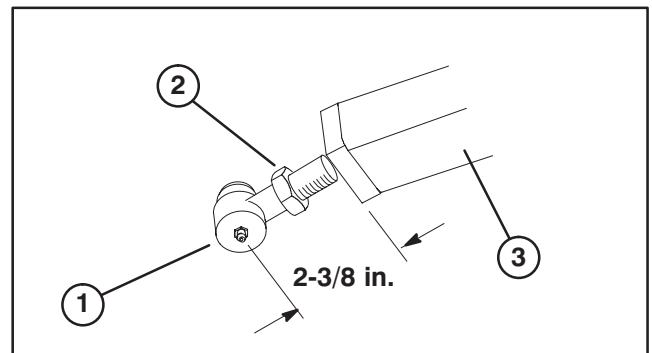

Figure 7

1. Ball joint
2. Jam nut
2. Left push arm

SETUP INSTRUCTIONS

3. Remove 2 flange head capscrews and flange nuts securing left-hand ball joint mount to castor arm. Remove ball joint mount from castor arm.

4. Install ball joint to left-hand ball joint mount with a castle nut and cotter pin.

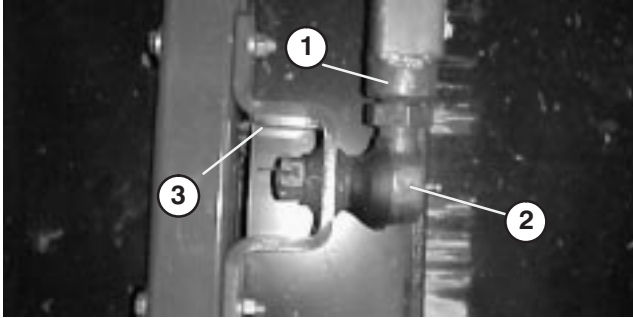

Figure 8

1. L.H. Push Arm
2. Ball joint
3. Ball Joint Mount

5. Have a helper carefully push down on the push arm until holes in ball joint mount line up with holes in castor arm. Immediately slide a 4 x 4 in. block of wood between top of push arm and underside of chassis.



WARNING

Make sure the wooden block does not slip out accidentally. Sudden release of the push arm could cause injury.

6. Secure ball joint mount to castor arm with flange head capscrews and flange nuts previously removed.

Note: Flange head capscrew heads to be positioned on inside of castor arm.

7. Tighten large jam nut securing ball joint to push arm. When tightening jam nut, hold ball joint straight to permit proper oscillation during raising and lowering of cutting unit. Carefully remove wood block holding push arm down.

Note: Position deck so there is a 2 in. gap between front of traction unit tires and rear of deck (Fig. 9).



Figure 9

8. Tighten fasteners securing right push arm adapter to right push arm.

Note: Periodically check and tighten the push arm adapter capscrews.

MOUNT FRONT LIFT ARM (Fig. 10 & 11)

1. Remove rubber bumper from bottom of traction T-bar.

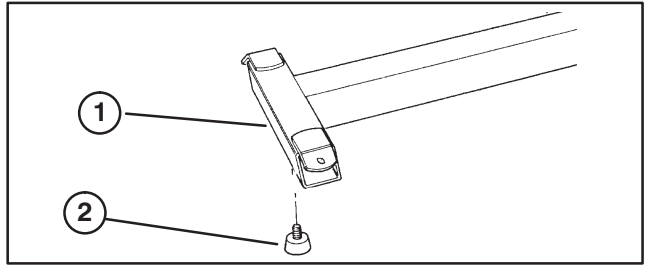

Figure 10

1. Traction T-bar
2. Rubber bumper

2. Slide front lift arm onto traction unit t-bar, positioning as shown in Figure 11.

3. Secure front lift arm to t-bar with with 2 capscrews and locknuts.

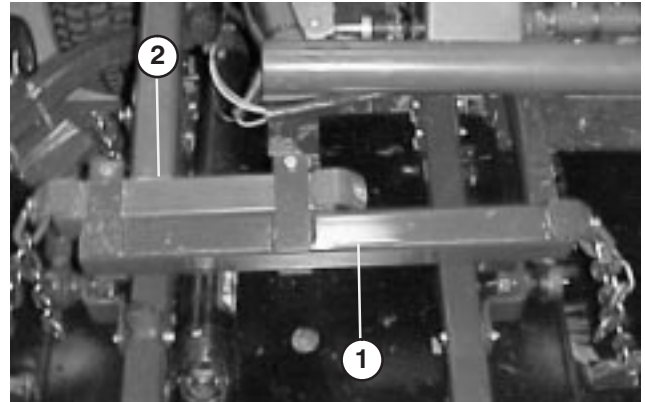

Figure 11

1. Front lift arm
2. Traction unit T-bar

MOUNT REAR LIFT BRACKET (Fig. 12–13)

1. Loosely mount rear lift bracket to right push arm with square U-bolt, 2 nuts, and flange nuts. Bracket to be positioned on push arm so it is centered and parallel to castor arm.

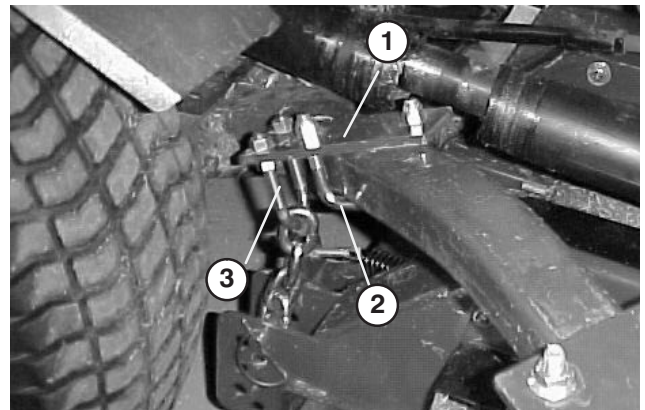

Figure 12

1. Lift bracket
2. Square u-bolt
3. U-bolt

SETUP INSTRUCTIONS

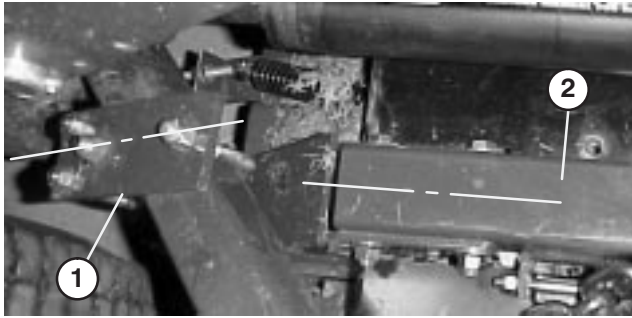

Figure 13

1. Lift bracket
2. Castor arm

2. Hook H.O.C. chain onto remaining U-bolt.
3. Thread a hex nut onto each end of U-bolt.
4. Loosely mount U-bolt and H.O.C. chain to rear lift bracket 2 nuts and 2 flange nuts
5. Mount height-of-cut chain to 2 in. height-of-cut hole with clevis pin and hairpin cotter.
6. Position rear castors in 2 in. height-of-cut.
7. Adjust nuts on U-bolt until rear of deck is parallel to floor (Distance from floor to bottom rear edge of all three deck chambers must be equal).

INSTALL DRIVE SHAFT TO TRACTION UNIT

NOTE: To ease installation of PTO shaft, remove right traction tire.

1. Slide smaller yoke end of drive shaft onto traction unit PTO shaft while aligning mounting holes. Secure with roll pin.

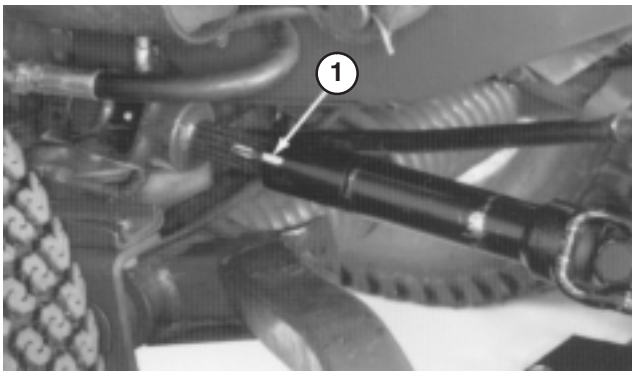

Figure 14

1. Drive shaft

INSTALL LIFT CHAINS (Fig. 15)

1. Connect lift chains to lift arm and cutting unit chain brackets with (6) shackles, (3/8 x 1-1/2 in.) shackle pins and (1/8 x 3/4 in.) cotter pins. To ensure that cutting unit lifts properly, secure chains to the following links when connecting:

- Front Left – 8th link
- Front Right – 8th link
- Rear – 14th link (All links)

Check operation to ensure that all chains lift deck tight against stops when lift arm is raised.

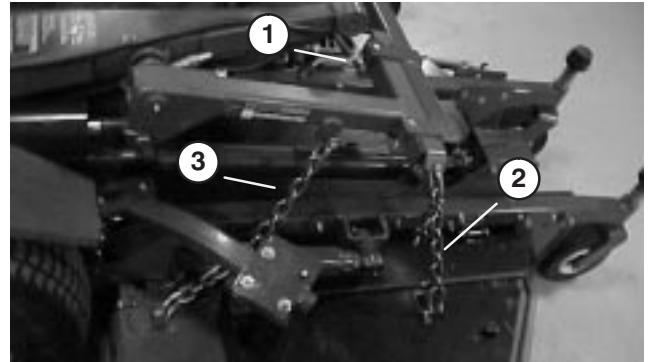

Figure 15

1. Front Left Lift Chain
2. Front Right Lift Chain
3. Rear Lift Chain

ADJUST COUNTER BALANCE SPRING

(Fig. 16)

1. Tighten nuts on adjusting rod until there is equal weight on castor wheels of left and left center chambers.

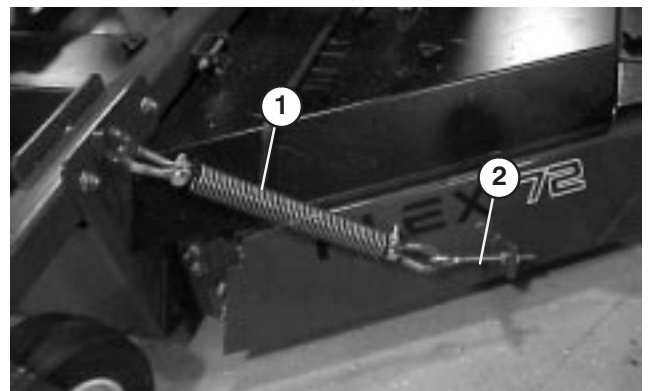

Figure 16

1. Counter balance spring
2. Adjusting rod

GREASE CUTTING UNIT

Before the cutting unit is operated, it must be greased to ensure proper lubricating characteristics: refer to Lubrication, page 13. Failure to properly grease the cutting unit will result in premature failure of critical parts.

SET-UP INSTRUCTIONS

INSTALL REAR WEIGHT

GROUNDMASTER 300 Series Traction Units comply with ANSI B71.4—1999 Standard when equipped with rear weight. Use chart below to determine combinations of weight required. Order parts from your local Authorized Toro Distributor.

Traction Unit Description	Rear Weight Required	Weight Part Number	Weight Description	Qty.
Groundmaster 325-D (30788/30739*)	210 lb.	24-5780	Rear Weight Kit (includes two 35 lb. weights and mounting hardware)	3
Groundmaster 328-D (30626/30630*)	210 lb.	24-5780	Rear Weight Kit (includes two 35 lb. weights and mounting hardware)	3
Groundmaster 345 (30789)	245 lb.	24-5780	Rear Weight Kit (includes two 35 lb. weights and mounting hardware)	3
		24-5790	& Rear Weight Kit (includes one 35 lb. weight and mounting hardware)	1
Groundmaster 325-D 4 Wheel Drive (30795/30741)	70 lb.	24-5780	Rear Weight Kit (includes two 35 lb. weights and mounting hardware)	1
Groundmaster 328-D 4 Wheel Drive (30627/30631)	70 lb.	24-5780	Rear Weight Kit (includes two 35 lb. weights and mounting hardware)	1

*Models 30739 and 30630 include 1 Rear Weight Kit.

BEFORE OPERATING

CHECK LUBRICANT IN GEAR BOX

The gear box is designed to operate on SAE 80–90 wt. gear lube. Although the gear box is shipped with lubricant from the factory, check the level before operating the cutting unit.

1. Position the machine on a level surface.
2. Remove check plug from side of gear box and make sure lubricant is up to bottom of hole. If level of lubricant is low, add enough lubricant to bring it up to bottom of hole.

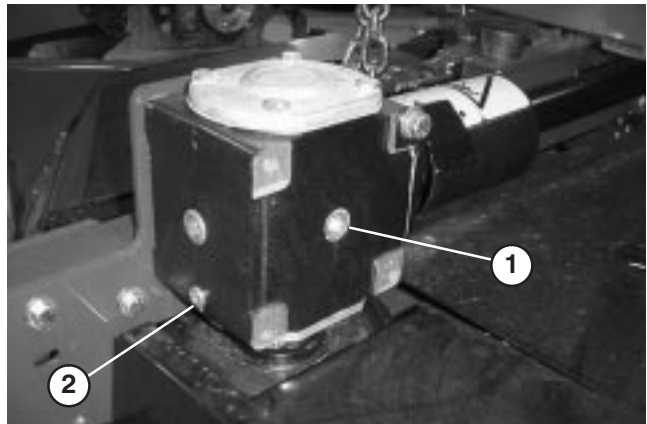

Figure 17

1. Fill/Check Plug

2. Drain Plug

BEFORE OPERATING

ADJUSTING HEIGHT-OF-CUT

The height-of-cut is adjustable from 1 to 4 inches in 1/4 inch increments.

1. Start the engine and raise the cutting unit so height-of-cut can be changed. Stop engine after cutting unit is raised.

FRONT CASTOR WHEELS

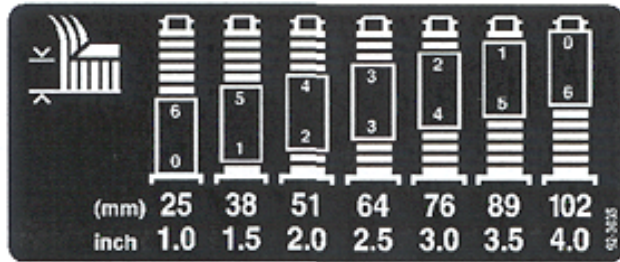

Figure 18

1. Remove H.O.C. cap from spindle shaft and slide spindle out of front castor arm. Slide spacers onto spindle shaft to get desired height-of-cut.

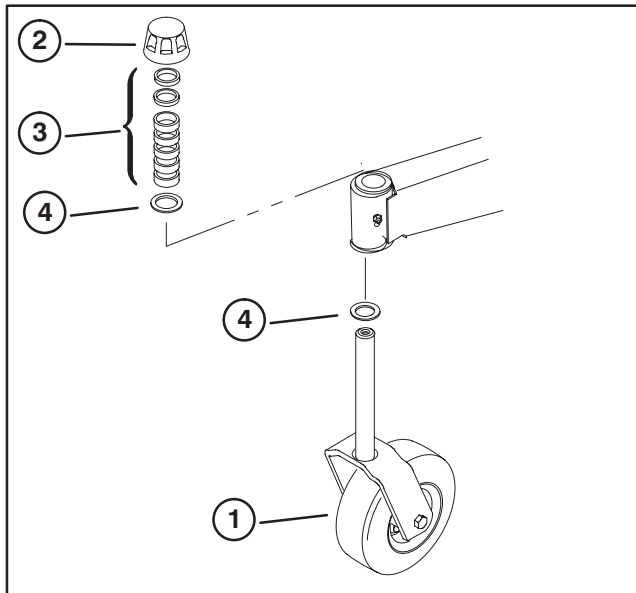

Figure 19

1. Front castor wheel
2. H.O.C. Cap
3. Spacer
4. Washer

2. Push castor spindle through front castor arm install remaining spacers onto spindle and install HOC cap to secure assembly.

REAR CASTOR WHEELS

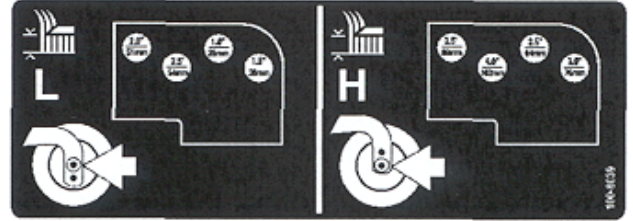

Figure 20

1. Remove hairpin cotter and cotter pin securing rear castor pivot arm to deck bracket.

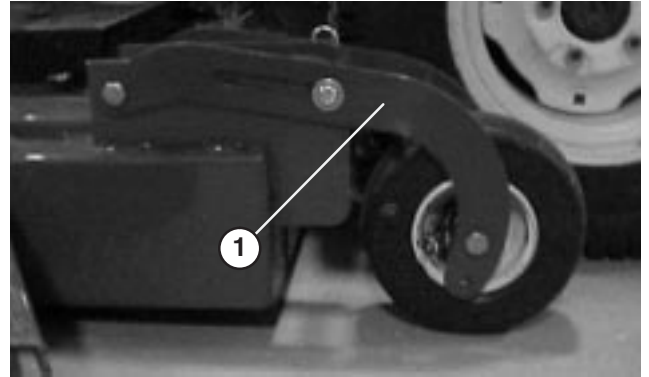

Figure 21

1. Rear Castor Pivot

2. Align the pivot arm holes with selected height-of-cut bracket holes in the deck frame, install cotter pin and secure with hairpin cotter.

REAR DECK CHAIN

1. Remove hair pin cotter and clevis pin securing height-of-cut chain to chamber bracket.
2. Mount height-of-cut chain to desired height-of-cut hole with clevis pin and hair pin cotter.

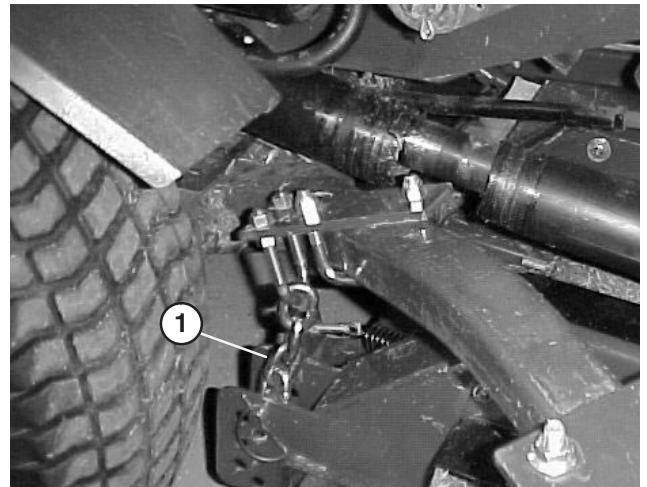

Figure 22

1. H.O.C. Chain

BEFORE OPERATING

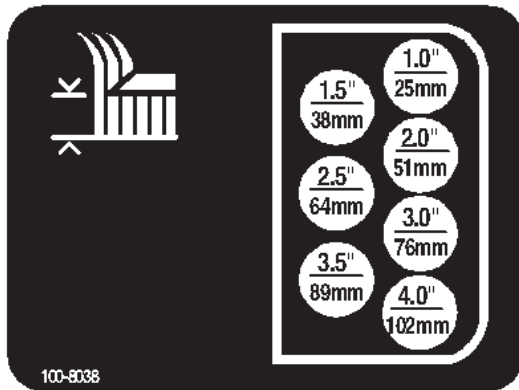

Figure 23

CHECK TIRE PRESSURE

Ensure that the air pressure in the front and rear castor wheels is 40 psi (276 kPa).

IMPORTANT: Maintain even pressure in all tires to ensure a good quality-of-cut and proper machine performance. **Do not under-inflate.**

ADJUST SKID

Skid, on right side of cutting unit, should be located in upper holes for 1 and 1-1/2 inch heights-of-cut and lower holes for 2 to 4 inch heights-of-cut.

1. Adjust skid by removing flange nuts, positioning as desired and re-installing flange nuts.

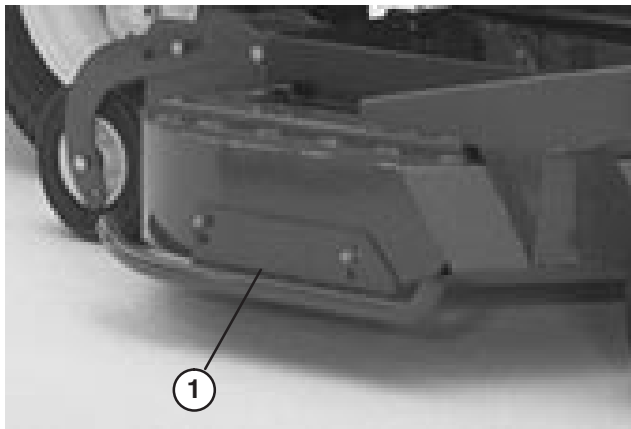

Figure 24
1. Skid

ADJUST ROLLERS

The front anti-scalp rollers and the rear anti-scalp rollers, located on the center deck, should be located in upper holes for 1 and 1-1/2 inch heights-of-cut and lower holes for 2 to 5 inch heights-of-cut. Six rollers are located on the deck, two under the main deck and two on each wing.

1. Adjust anti-scalp rollers by removing screw securing roller shaft to deck, positioning roller as desired, and reinstalling shaft with screw, washers, and nut (Fig. 25).
2. The two outside wing deck rollers can be adjusted at the roller, or the bracket can be repositioned on the deck.

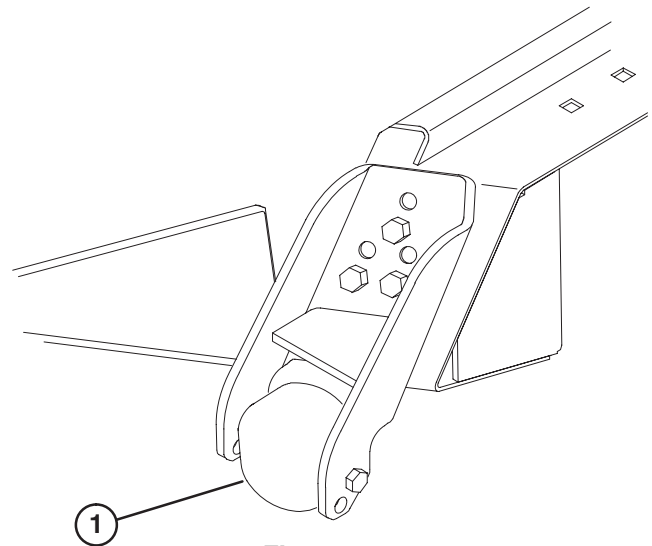

Figure 25
1. Roller

OPERATING INSTRUCTIONS

GRASS DEFLECTOR (Fig. 26)



WARNING

The grass deflector (Fig. 26) is a safety device that diverts grass and other foreign objects being discharged downward. WE STRONGLY RECOMMEND THAT THE DEFLECTOR BE IN ITS NORMAL OPERATING POSITION WHENEVER THE CUTTING UNIT IS ENGAGED. NEVER OPERATE CUTTING UNIT WITH THE DEFLECTOR REMOVED FROM THE CUTTING UNIT OR IT TIED/BLOCKED IN A RAISED POSITION. SINCE THE BLADES COULD THEN THROW DEBRIS A CONSIDERABLE DISTANCE WITH SUFFICIENT FORCE TO CAUSE PERSONAL INJURY OR DAMAGE TO PROPERTY. If the grass deflector is damaged, repair or replace the affected part(s).

Note: The deflector is spring loaded into its downward normal operating position, but the operator can temporarily swing it out of the way to facilitate loading in a trailer or when otherwise necessary.

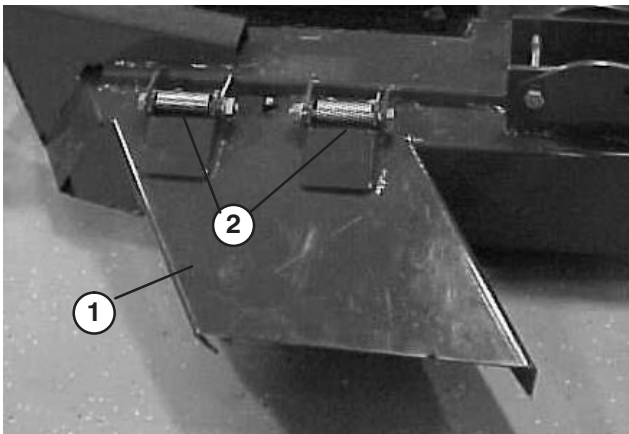

Figure 26

1. Grass deflector
2. Springs

OPERATING TIPS

1. **MOW WHEN GRASS IS DRY**—Mow either in the late morning to avoid the dew, which causes grass clumping or in late afternoon to avoid the damage that can be caused by direct sunlight on the sensitive, freshly mowed grass.

2. **SELECT THE PROPER HEIGHT—OF—CUT SETTING TO SUIT CONDITIONS** — Remove approximately one inch or no more than 1/3 of the grass blade when cutting. In exceptionally lush and dense grass you may have to raise your height—of—cut setting another notch. When cutting in 1 in. or 1-1/2 in. height-of-cut, add a second washer between rear castor forks and bottom of castor arm housings to increase blade rake.

3. **MOWING IN EXTREME CONDITIONS** — Air is required to cut and recut grass clippings in mower housing, so do not set height-of-cut too low or totally surround housing by uncut grass. Always try to have one side of the mower housing free from uncut grass, allowing air to be drawn into housing. When making an initial cut thru center of uncut area, operate machine slower and back up if mower starts to clog.

4. **ALWAYS START MOWING WITH SHARP BLADES** — A sharp blade cuts cleanly and without tearing or shredding the grass blades like a dull blade. Tearing and shredding causes the grass to turn brown at the edges which impairs growth and increases susceptibility to diseases. Make sure blade is in good condition and a full sail is present.

5. **CHECK CONDITION OF DECK** — Make sure cutting chambers are in good condition. Straighten any bends in chamber components to ensure correct blade tip/chamber clearance.

6. **STOPPING** — If forward motion has to be stopped while cutting, a clump of grass clippings may be deposited on lawn. Follow this procedure for stopping while cutting:

- A. With deck engaged, move onto a previously cut area.
- B. Shift to neutral, move throttle control lever to SLOW position and rotate ignition key to OFF.

7. **AFTER OPERATING** — To ensure optimum performance, clean underside of mower housing, especially around inserts (kickers) after each use. If residue is allowed to build up in mower housing and on inserts, cutting performance will decrease.

LUBRICATION

GREASING THE CUTTING UNIT

The cutting unit must be lubricated regularly. If machine is operated under normal conditions, lubricate castor bearings and bushings with No. 2 general purpose lithium base grease or molybdenum base grease, after every 8 hours of operation or daily, whichever comes first.

1. The cutting unit has bearings and bushings that must be lubricated, and these lubrication points are: front castor spindle bushings (2) (Fig. 27); front castor wheel bearings (4) (Fig. 27); rear castor wheel bearings (2) (Fig. 28); blade spindle bearings (3) (Fig. 29); right and left push arm ball joints (Fig. 29); drive shaft (3) (Fig. 29) idler arm pivots (3) (Fig. 30); and deck pivot pins (4) (Fig. 31)

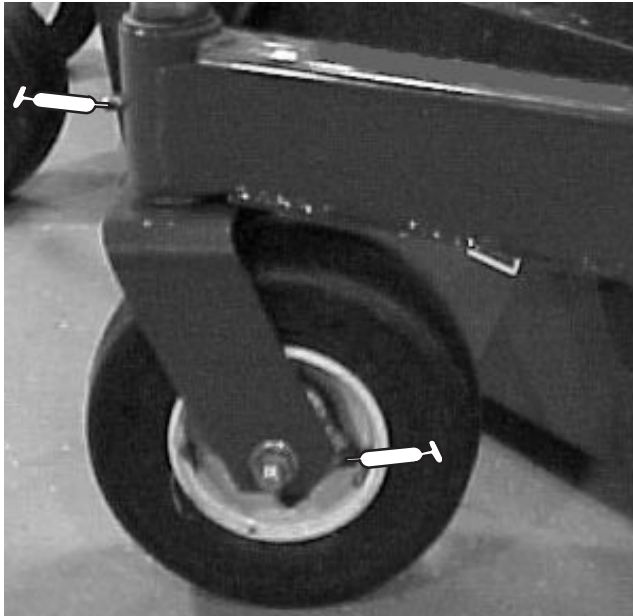

Figure 27

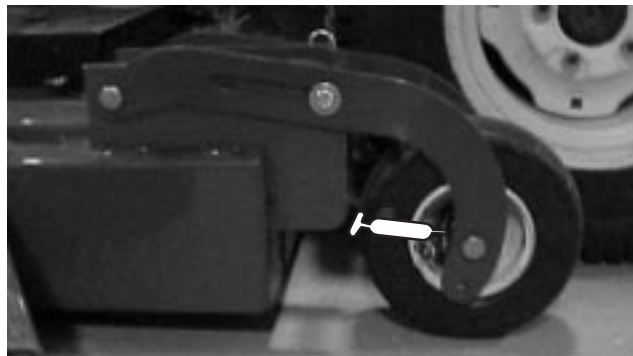

Figure 28

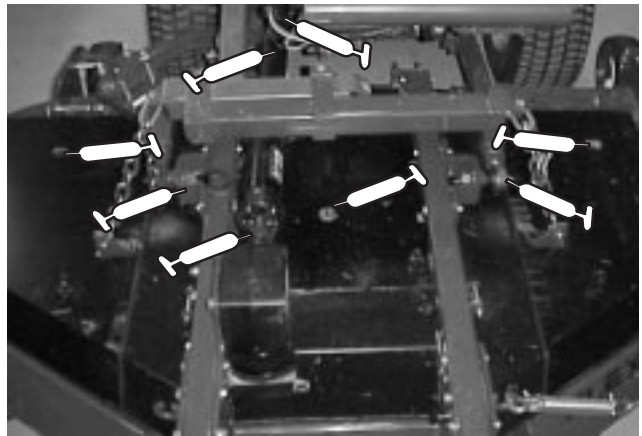

Figure 29



Figure 30



Figure 31

2. Position the machine on a level surface and lower cutting unit. Remove fill/check plug from side of gear box (Fig. 32) and make sure lubricant is up to bottom of hole. If level of lubricant is low, add SAE 80–90 wt. gear lube until level is up to bottom of hole.

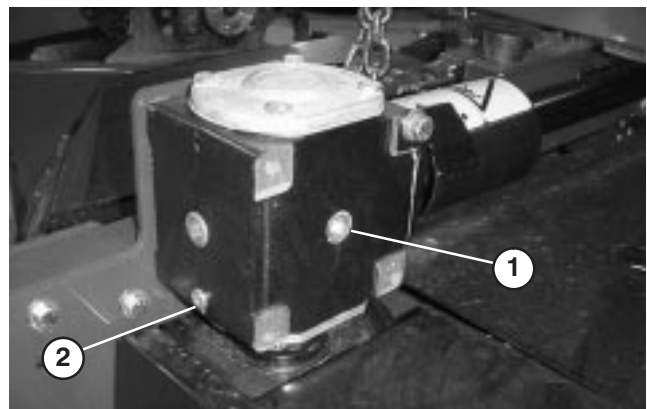
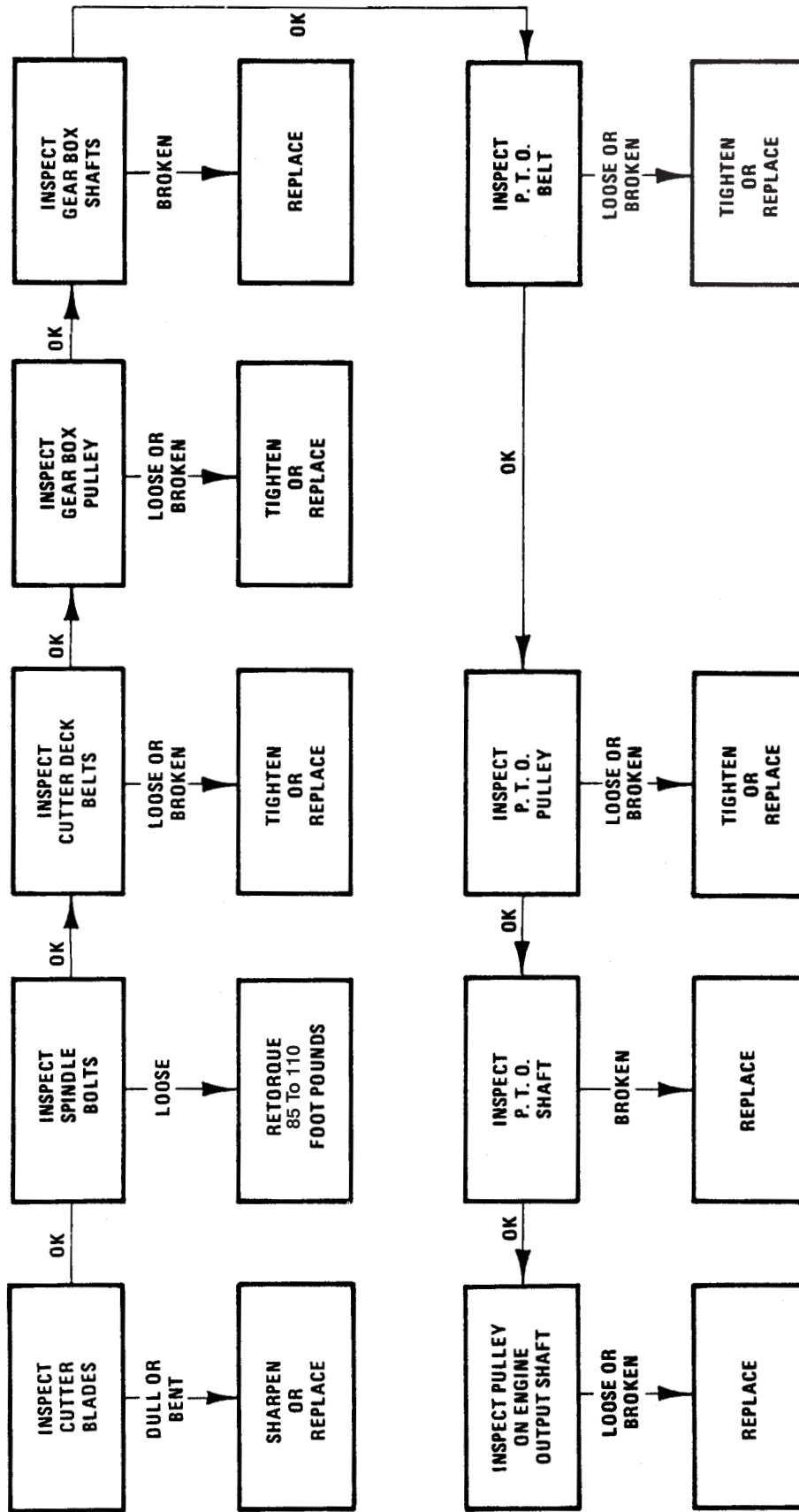

Figure 32

1. Fill/Check Plug 2. Drain Plug

MAINTENANCE TROUBLE SHOOTING

UNIT WILL NOT CUT OR CUTS POORLY



MAINTENANCE



CAUTION

To prevent accidental starting of the engine, while performing maintenance, shut engine off and remove key from ignition switch.

SEPARATING CUTTING UNIT FROM TRACTION UNIT

1. Position machine on level surface, lower cutting unit to floor, shut engine off and engage parking brake.
2. Remove self tapping screws securing shield to top of cutting unit and set shield aside.
3. Drive out roll pin securing drive shaft yoke to input shaft of gear box. Loosen capscrews and locknuts and slide yoke off input shaft. If traction unit will be used without the cutting unit, drive roll pin out of yoke at traction unit PTO shaft and remove entire drive shaft from traction unit.



DANGER

Do not start the engine and engage the PTO lever when PTO shaft is not connected to gear box on cutting unit. If engine is started and PTO shaft is allowed to rotate, serious injury could result.

4. Disconnect cotter pins and clevis pins securing lift chains to lift arms.



WARNING

Since the right hand push arm is spring loaded to about 100 pounds and the left hand push arm is spring loaded to about 150 pounds, a helper is needed to push the arm down. Sudden release of the push arm could cause injury.

5. Have a helper push down on the right push arm while you remove the flange head capscrews and locknuts securing the ball joint mount to castor arm on cutting unit. Now the helper can carefully allow push arm to move upward, which will gradually release the 100 pounds of spring load.
6. Have a helper push down on the left push arm while you remove the flange head capscrews and locknuts securing the ball joint mount to castor arm on cutting unit. Now the helper can carefully allow push arm to move upward, which will gradually release the 150 pounds of spring load.
7. Roll the cutting unit away from the traction unit.

MOUNTING CUTTING UNIT TO TRACTION UNIT

1. Position machine on a level surface and shut engine off.
2. Move cutting unit into position in front of traction unit.



WARNING

Since the right hand push arm is spring loaded to about 100 pounds and the left hand push arm is spring loaded to about 150 pounds, a helper is needed to push the arm down. Sudden release of the push arm could cause injury.

3. Have a helper carefully push down on the right push arm until holes in ball joint mount line up with holes in castor arm.
4. Secure ball joint mount to castor arm with flange head capscrews and flange nuts. Capscrew heads to be positioned to inside of castor arm.
5. Have a helper carefully push down on the left push arm until holes in ball joint mount line up with holes in castor arm. Immediately slide a 4 x 4 in. block of wood between top of push arm and underside of chassis



WARNING

Make sure the wooden block does not slip out accidentally. Sudden release of the push arm could cause injury.

6. Secure ball joint mount to castor arm with flange head capscrews and flange nuts. capscrew heads to be positioned to inside of castor arm. Chain bracket to be mounted in forward set of holes.
7. Carefully remove wood block holding push arm down.
8. Line up holes in yoke and input shaft of gear box. Slide yoke onto shaft and secure together with a roll pin and 2 capscrews (5/16 x 1-3/4 in.) and locknuts (5/16 in.).

ADJUSTING DRIVE BELTS (Fig. 33)

The blade drive belts are tensioned by the spring loaded idlers, are very durable. However, after many hours of use, the belts will stretch and will need adjusting.

1. Lower cutting unit to the shop floor. Remove belt covers from top of cutting unit and set covers aside.
2. Adjust spring tensioning rods until 10 lb. tension is achieved for side belts and 30 lb. tension for center gear box belt.

MAINTENANCE



Figure 33
1. Spring tensioning rod (3)

REPLACING DRIVE BELTS

The blade drive belts, tensioned by the spring loaded idlers, are very durable. However, after many hours of use, the belts will show signs of wear. Signs of a worn belt are: squealing when belt is rotating, blades slipping when cutting grass, frayed edges, burn marks, and cracks. Replace the belt if any of these conditions are evident.

1. Lower cutting unit to the shop floor. Remove belt covers from top of cutting unit and set covers aside.
2. To replace gear box belt, loosen spring tension rod and remove belt. Retention new belt to 30 lb. Refer to Figure 34 for belt routing.

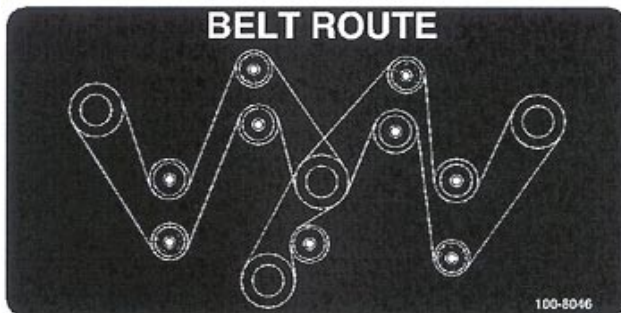

Figure 34

3. To replace wing belts, loosen spring tension rod and remove gear box belt.
4. Pull spring loaded idler pulley away from belt, with hand, to relieve belt tension and remove belt. Retention new belts to 10 lb. Refer to Figure 34 for belt routing.
8. Install belt covers.

SERVICING FRONT BUSHINGS IN CASTOR ARMS

The castor arms have bushings pressed into the top and bottom of the tube and after many hours of operation, the bushings will wear. To check the bushings, move castor fork back and forth and from side to side. If castor spindle is loose inside the bushings, bushings are worn and must be replaced.

1. Raise cutting unit so wheels are off floor and block it so it cannot fall accidentally.
2. Remove tensioning cap, spacer(s) and thrust washer from top of castor spindle.
3. Pull castor spindle out of mounting tube. Allow thrust washer and spacer(s) to remain on bottom of spindle.
4. Insert pin punch into top or bottom of mounting tube and drive bushing out of tube. Also drive other bushing out of tube. Clean inside of tubes to remove dirt.

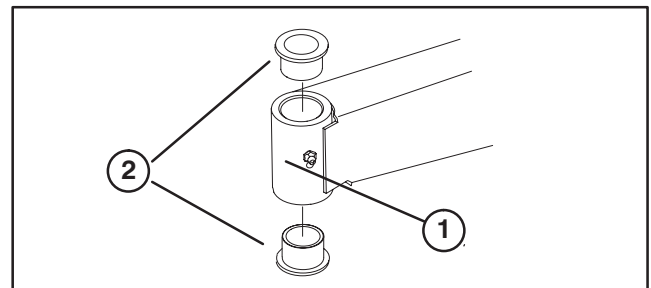

Figure 35
1. Front Castor Arm Tube
2. Bushings

5. Apply grease to inside and outside of new bushings. Using a hammer and flat plate, drive bushings into mounting tube.
6. Inspect castor spindle for wear and replace it if damaged.
7. Push castor spindle through bushings and mounting tube. Slide thrust washer and spacer(s) onto spindle. Install tensioning cap on castor spindle to retain all parts in place.

SERVICING CASTOR WHEELS AND BEARINGS

The castor wheel rotates on a high-quality roller bearing and is supported by a spanner bushing. Even after many hours of use, provided that the bearing was kept well-lubricated, bearing wear will be minimal. However, failure to keep bearing lubricated will cause rapid wear. A wobbly castor wheel usually indicates a worn bearing.

MAINTENANCE

1. Remove locknut from capscrew holding castor wheel assembly between castor fork. Grasp castor wheel and slide capscrew out of fork.
2. Pull spanner bushing out of wheel hub.

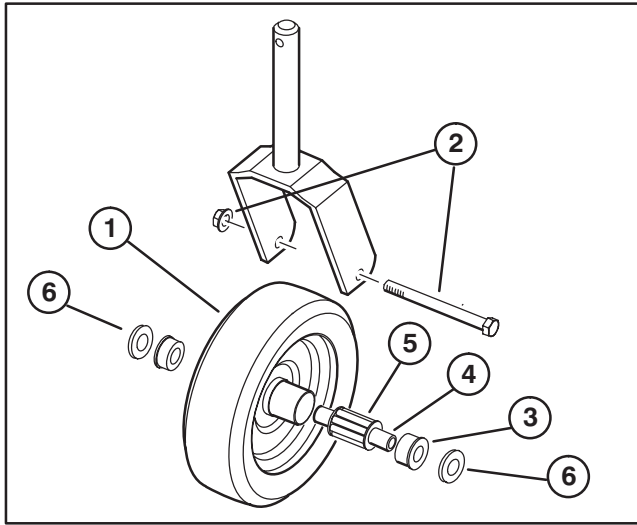

Figure 36

- | | |
|-----------------------|--------------------|
| 1. Castor wheel | 4. Spanner Bushing |
| 2. Capscrew & Locknut | 5. Roller Bearing |
| 3. Bushing (2) | 6. Washer (2) |

3. Remove bushing from wheel hub and allow bearing to fall out. Remove bushing from opposite side of wheel hub.
4. Check the bearing, spanner and inside of wheel hub for wear. Replace defective parts.
5. To assemble the castor wheel, push bushing into wheel hub. Slide bearing into wheel hub. Push other bushing into open end of wheel hub to captivate the bearing inside the wheel hub.
6. Carefully slide spanner through the bushings and the wheel hub.
7. Install castor wheel assembly between castor fork and secure in place with capscrew, washers and locknut.
8. Lubricate castor wheel bearing through grease fitting, using No. 2 general purpose lithium base grease.

REPLACING GRASS DEFLECTOR (Fig. 37)

1. Position machine on a level surface, raise cutting unit, engage parking brake, be sure traction pedal is in neutral position, PTO lever in OFF position, shut engine OFF, and remove key from switch. Block cutting unit to prevent it from falling accidentally.

2. Remove two capscrews, locknuts, and springs securing deflector mounts to pivot brackets.
3. To remove the pivot brackets, remove carriage bolts and nuts.
4. Reinstall pivot brackets on top of discharge opening with carriage bolts and nuts. Head of carriage bolts must be on inside of cutting unit.
5. Position deflector mounts on pivot brackets and secure parts together with capscrews, locknuts and springs. Both locknuts must face each other. Tighten locknuts until they are flush against deflector pivots.

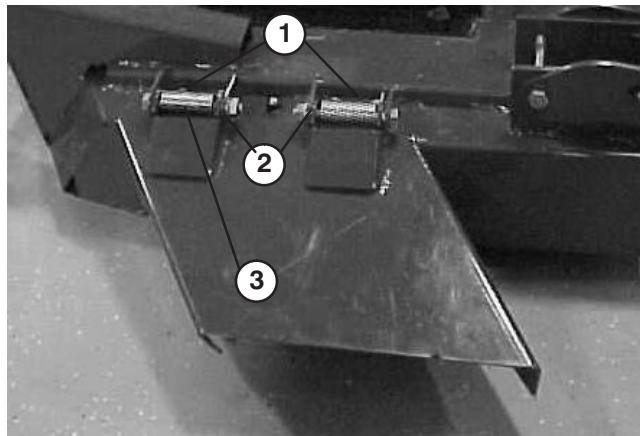

Figure 37

1. Deflector mounts
2. Pivot brackets
3. Pivot springs

6. Lift deflector and allow it to drop to check spring tension. Deflector must be held firmly in full downward position by spring tension. Correct if necessary.

REMOVING CUTTER BLADE (Fig. 38)

The blade must be replaced if a solid object is hit, the blade is out-of-balance or if the blade is bent. Always use genuine Toro replacement blades to be sure of safety and optimum performance. Never use replacement blades made by other manufacturers because they could be dangerous.

1. Raise cutting unit to highest position, shut the engine off and engage the parking brake. Block cutting unit to prevent it from falling accidentally.
2. Grasp end of blade using a rag or thickly padded glove. Remove blade bolt, lock washer, anti-scalp cup, and blade from spindle shaft.

MAINTENANCE

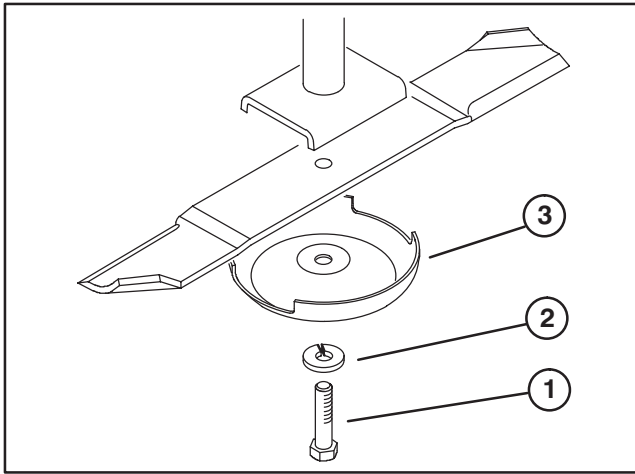

Figure 38

1. Blade bolt
2. Lockwasher
3. Anti-Scalp Cup

2. Install blade—sail facing toward cutting unit with anti-scalp cup, lock washer, and blade bolt. Tighten blade bolt to 85–110 ft.-lb.



WARNING

Do not try to straighten a blade that is bent, and never weld a broken or cracked blade. Always use a new blade to ensure continued safety certification of the product.

INSPECTING AND SHARPENING BLADE

1. Raise cutting unit to highest position, shut the engine off and engage the parking brake. Block cutting unit to prevent it from falling accidentally.
2. Examine cutting ends of the blade carefully, especially where the flat and curved parts of the blade meet (Fig. 39-A). Since sand and abrasive material can wear away the metal that connects the flat and curved parts of the blade, check the blade before using the machine. If wear is noticed (Fig. 39-B), replace the blade: refer to Removing Cutter Blade.

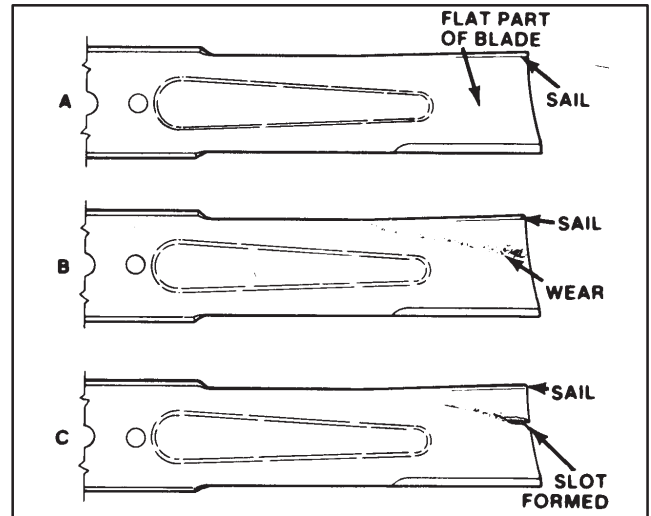

Figure 39



DANGER

If blade is allowed to wear, a slot will form between the sail and flat part of the blade (Fig. 39-C). Eventually a piece of the blade may break off and be thrown from under the housing, possibly resulting in serious injury to yourself or bystander.

3. Inspect cutting edges of all blades. Sharpen the cutting edges if they are dull or nicked. Sharpen only the top of the cutting edge and maintain the original cutting angle to make sure of sharpness (Fig. 27). The blade will remain balanced if same amount of metal is removed from both cutting edges.

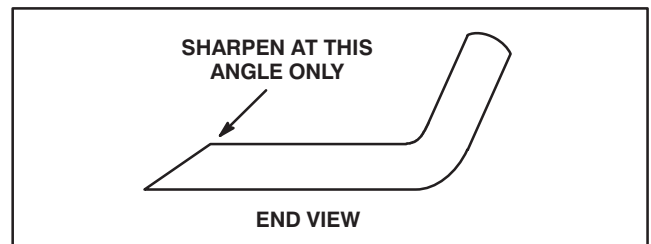

Figure 40

4. To check blade for being straight and parallel, lay blade on a level surface and check its ends. Ends of blade must be slightly lower than the center, and cutting edge must be lower than the heel of the blade. This blade will produce good quality of cut and require minimal power from the engine. By contrast a blade that is higher at the ends than the center, or if cutting edge is higher than the heel, the blade is bent or warped and must be replaced.
5. Install blade—sail facing toward cutting unit with anti-scalp cup, lock washer, and blade bolt. Tighten blade bolt to 85–110 ft.-lb.

MAINTENANCE

CORRECTING CUTTING UNIT MISMATCH

If there is mismatch between the blades, the grass will appear streaked when it is cut. This problem can be corrected by making sure the blades are straight and all blades are cutting on the same plane.

1. Using a 3 foot long carpenters level, find a level surface on the shop floor.
2. Raise height-of-cut to the highest position: refer to Adjusting Height-of-Cut.
3. Lower cutting unit onto flat surface. Remove covers from top of cutting unit.
4. Unhook spring from idler arm bracket to release belt tension.
5. Rotate blades until the ends face forward and backward. Measure from floor to front tip of cutting edge and remember this dimension. Then rotate same blade so opposite end is forward and measure again. The difference between dimensions must not exceed 1/8 of an inch. If dimension exceeds 1/8 of an inch, replace the blade because it is bent. Make sure to measure all blades.

6. Compare measurements of outer blades with the center blade. Center blade must not be more than 3/8 of an inch lower than the outer blades. If center blade is more than 3/8 of an inch lower than the outer blades, proceed to step 7 and add shims between spindle housing and bottom of cutting unit.

7. Remove capscrews, flatwashers, lockwashers and nuts from outer spindle in the area where shims must be added. To raise or lower the blade, add a shim, Part No. 3256-24, between spindle housing and bottom of cutting unit. Continue to check alignment of blades and add shims until tips of blades are within the required dimension.

IMPORTANT: Do not use more than three shims at any one hole location. Use decreasing numbers of shims in adjacent holes if more than one shim is added to any one hole location.

8. Hook spring onto idler arm bracket. Reinstall belt covers.

IDENTIFICATION AND ORDERING

MODEL AND SERIAL NUMBERS

The cutting deck has two identification numbers: a model number and a serial number. The two numbers are stamped into a plate on rear of the mower deck, under cover. In any correspondence concerning the mower, supply the model and serial numbers to ensure that correct information and replacement parts are obtained.

To order replacement parts from an authorized Toro Distributor, supply the following information:

1. Model and serial numbers of the machine.
2. Part number, description and quantity of parts desired.

Note: Do not order by reference number if a parts catalog is being used; use the part number.