



Mid-Size Mower

ProLine Gear 17 HP with 52 in. Side Discharge Mower

30260—210005001 and Up

Operator's Manual



Warning



The engine exhaust from this product contains chemicals known to the State of California to cause cancer, birth defects, or other reproductive harm.

Important This engine is not equipped with a spark arrester muffler. It is a violation of California Public Resource Code Section 4442 to use or operate this engine on any forest-covered, brush-covered or grass-covered land. Other states or federal areas may have similar laws.

This spark ignition system complies with Canadian ICES-002.

Ce système d'allumage par étincelle de véhicule est conforme à la norme NMB-002 du Canada.

The enclosed Engine Owner's Manual is supplied for information regarding The U.S. Environmental Protection Agency (EPA) and the California Emission Control Regulation of emission systems, maintenance and warranty.

Keep this engine Owner's Manual with your unit. Should this engine Owner's Manual become damaged or illegible, replace immediately. Replacements may be ordered through the engine manufacturer.

Contents

	Page
Introduction	3
Safety	3
Safe Operating Practices	3
Toro Mower Safety	5
Slope Chart	7
Safety and Instruction Decals	9
Gasoline and Oil	12
Recommended Gasoline	12
Using Stabilizer/Conditioner	12
Filling the Fuel Tank	12
Check Engine Oil Level	12
Assembly	13
Loose Parts	13
Installing the Control Panel and Fuel Tank	13
Installing the Shift Lever	14
Installing the Upper Handle	15
Installing the Control Rods	15
Installing Hairpin Cotter Pins	16
Operation	16
Think Safety First	17
Controls	17

	Page
Using the Parking Brake	17
Starting and Stopping the Engine	18
Operating Mower Blade Control (PTO)	18
The Safety Interlock System	19
Driving Forward or Backward	19
Operating Lower Control Bar	20
Stopping the Machine	20
Transporting Machines	20
Using Side Discharge or Mulch Grass	21
Adjusting Height-of-Cut	21
Adjusting Gage Wheels	21
Adjusting Center Gage Wheels	22
Maintenance	23
Recommended Maintenance Schedule	23
Servicing the Air Cleaner	24
Servicing the Engine Oil	25
Servicing the Spark Plug	26
Greasing and Lubrication	27
Cleaning the Cooling System	28
Checking Tire Pressure	28
Servicing the Brake	28
Adjusting the Electric Clutch	29
Servicing the Fuel Tank	30
Servicing the Fuel Filter	30
Servicing the Fuse	31
Servicing the Cutting Blade	31
Correcting Cutting Unit Mismatch	33
Setting Up the Frame	33
Checking the Deck Front-to-Rear Pitch	35
Changing the Deck Front-to-Rear Pitch	35
Checking the Deck Side-to-Side Level	36
Changing the Side-to-Side Level	36
Matching Height of Cut	36
Replacing the Drive Belt	36
Replacing the Traction Belt	37
Replacing the Deck Belt	37
Replacing the PTO Drive Belt	38
Replacing the Caster Wheel Fork Bushings	38
Caster Wheel and Bearings Service	39
Replacing the Grass Deflector	40
Wiring Diagram	41
Cleaning and Storage	42
Troubleshooting	42
The Toro Total Coverage Guarantee	48

Introduction

Read this manual carefully to learn how to operate and maintain your product properly. The information in this manual can help you and others avoid injury and product damage. Although Toro designs and produces safe products, you are responsible for operating the product properly and safely.

Whenever you need service, genuine Toro parts, or additional information, contact an Authorized Service Dealer or Toro Customer Service and have the model and serial numbers of your product ready. Figure 1 illustrates the location of the model and serial numbers on the product.

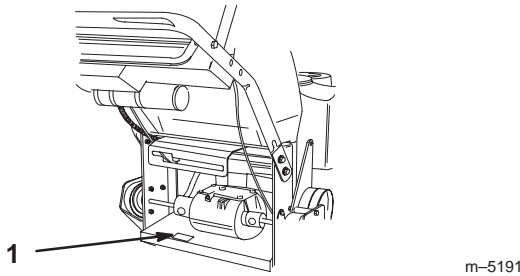

Figure 1

1. Location of the model and serial numbers

Write the product model and serial numbers in the space below:

Model No. _____
Serial No. _____

This manual identifies potential hazards and has special safety messages that help you and others avoid personal injury and even death. **Danger**, **Warning**, and **Caution** are signal words used to identify the level of hazard. However, regardless of the hazard, be extremely careful.

Danger signals an extreme hazard that *will* cause serious injury or death if you do not follow the recommended precautions.

Warning signals a hazard that *may* cause serious injury or death if you do not follow the recommended precautions.

Caution signals a hazard that may cause minor or moderate injury if you do not follow the recommended precautions.

This manual uses two other words to highlight information. **Important** calls attention to special mechanical information and **Note**: emphasizes general information worthy of special attention.

Safety

This machine meets or exceeds the B71.4 1999 specifications of the American National Standards Institute, in effect at time of production.

Note: The addition of attachments made by other manufacturers that do not meet American National Standards Institute certification will cause noncompliance of this machine.

Improper use or maintenance by the operator or owner can result in injury. To reduce the potential for injury, comply with these safety instructions and always pay attention to the safety alert symbol, which means CAUTION, WARNING, or DANGER— personal safety instruction. Failure to comply with the instruction may result in personal injury or death.

Safe Operating Practices

The following instructions are from ANSI standard B71.4—1999.

Training

- Read the Operator's Manual and other training material. If the operator(s) or mechanic(s) can not read English it is the owner's responsibility to explain this material to them.
- Become familiar with the safe operation of the equipment, operator controls, and safety signs.
- All operators and mechanics should be trained. The owner is responsible for training the users.
- Never let children or untrained people operate or service the equipment. Local regulations may restrict the age of the operator.
- The owner/user can prevent and is responsible for accidents or injuries occurring to himself or herself, other people or property.

Preparation

- Evaluate the terrain to determine what accessories and attachments are needed to properly and safely perform the job. Only use accessories and attachments approved by the manufacturer.
- Wear appropriate clothing including hard hat, safety glasses and ear protection. Long hair, loose clothing or jewelry may get tangled in moving parts.
- Inspect the area where the equipment is to be used and remove all objects such as rocks, toys and wire which can be thrown by the machine.

- Use extra care when handling gasoline and other fuels. They are flammable and vapors are explosive.
 - Use only an approved container
 - Never remove gas cap or add fuel with engine running. Allow engine to cool before refueling. Do not smoke.
 - Never refuel or drain the machine indoors.
- Check that operator's presence controls, safety switches and shields are attached and functioning properly. Do not operate unless they are functioning properly.
- Slow down and use caution when making turns and crossing roads and sidewalks. Stop blades if not mowing.
- Be aware of the mower discharge direction and do not point it at anyone.
- Do not operate the mower under the influence of alcohol or drugs
- Use care when loading or unloading the machine into or from a trailer or truck
- Use care when approaching blind corners, shrubs, trees, or other objects that may obscure vision.

Operation

- Never run an engine in an enclosed area.
- Only operate in good light, keeping away from holes and hidden hazards.
- Be sure all drives are in neutral and parking brake is engaged before starting engine. Only start engine from the operator's position.
- Slow down and use extra care on hillsides. Be sure to travel side-to-side on hillsides. Turf conditions can affect the machine's stability. Use caution while operating near drop-offs.
- Slow down and use caution when making turns and when changing directions on slopes.
- Never raise deck with the blades running.
- Never operate with the PTO shield, or other guards not securely in place. Be sure all interlocks are attached, adjusted properly, and functioning properly.
- Never operate with the discharge deflector raised, removed or altered, unless using a grass catcher.
- Do not change the engine governor setting or overspeed the engine.
- Stop on level ground, disengage drives, engage parking brake (if provided), shut off engine before leaving the operator's position for any reason including emptying the catchers or unclogging the chute.
- Stop equipment and inspect blades after striking objects or if an abnormal vibration occurs. Make necessary repairs before resuming operations.
- Keep hands and feet away from the cutting unit.
- Look behind and down before backing up to be sure of a clear path.
- Keep pets and bystanders away.

Maintenance and storage

- Disengage drives, set parking brake, stop engine and remove key or disconnect spark plug wire. Wait for all movement to stop before adjusting, cleaning or repairing.
- Clean grass and debris from cutting unit, drives, mufflers, and engine to help prevent fires. Clean up oil or fuel spillage.
- Let engine cool before storing and do not store near flame.
- Shut off fuel while storing or transporting. Do not store fuel near flames or drain indoors.
- Park machine on level ground. Set parking brake. Never allow untrained personnel to service machine.
- Use jack stands to support components when required.
- Carefully release pressure from components with stored energy.
- Disconnect battery or remove spark plug wire before making any repairs. Disconnect the negative terminal first and the positive last. Reconnect positive first and negative last.
- Use care when checking blades. Wrap the blade(s) or wear gloves, and use caution when servicing them. Only replace blades. Never straighten or weld them.
- Keep hands and feet away from moving parts. If possible, do not make adjustments with the engine running.
- Charge batteries in an open well ventilated area, away from spark and flames. Unplug charger before connecting or disconnecting from battery. Wear protective clothing and use insulated tools.
- Keep all parts in good working condition and all hardware tightened. Replace all worn or damaged decals.

Toro Mower Safety

The following list contains safety information specific to Toro products and other safety information you must know.

This product is capable of amputating hands and feet and throwing objects. Always follow all safety instructions to avoid serious injury or death.

This product is designed for cutting and recycling grass or, when equipped with a grass bagger, for catching cut grass. Any use for purposes other than these could prove dangerous to user and bystanders.

General Operation

- Allow only responsible adults who are familiar with the instructions to operate the machine.
- Be sure the area is clear of other people before mowing. Stop the machine if anyone enters the area.
- Do not mow in reverse unless absolutely necessary. Always look down and behind before and while backing.
- Be aware of the mower discharge direction and do not point it at anyone. Do not operate the mower without either the entire grass catcher or the guard in place.
- Slow down before turning. Sharp turns on any terrain may cause loss of control.
- Turn off blades when not mowing.
- Keep hands, feet, hair and loose clothing away from attachment discharge area, underside of mower and any moving parts while engine is running.
- Stop the engine before removing the grass catcher or unclogging the chute.
- Mow only in daylight or good artificial light.
- Watch for traffic when operating near or crossing roadways.
- Do not touch equipment or attachment parts which may be hot from operation. Allow to cool before attempting to maintain, adjust or service.
- Use only Toro-approved attachments. Warranty may be voided if used with unapproved attachments.

Slope Operation

Slopes and ramps are a major factor related to loss-of-control and accidents, which can result in severe injury or death. All slopes and ramps require extra caution. If you feel uneasy on a slope, do not mow it.

DO

- Remove obstacles such as rocks, tree limbs, etc. from the mowing area. Watch for holes, ruts or bumps. Tall grass can hide obstacles.
- Use slow speed so that you will not have to stop while on the slope.
- Use extra care with grass catchers or other attachments. These can change the stability of the machine.
- Keep all movement on slopes slow and gradual. Do not make sudden changes in speed or direction.
- Avoid starting or stopping on a slope. If tires lose traction, disengage the blades.
- Check carefully for overhead clearances (i.e. branches, doorways, electrical wires) before driving under any objects and do not contact them.
- Mow slopes side-to-side.

DO NOT

- Do not mow slopes greater than 15 degrees.
- Avoid turning on slopes. If you must turn, turn slowly and gradually downhill, if possible.
- Do not mow near drop-offs, ditches, or embankments. The machine could suddenly turn over if a wheel goes over the edge of a cliff or ditch, or if an edge caves in.
- Do not mow on wet grass. Reduced traction could cause sliding.
- Do not use a grass catcher on steep slopes. Heavy grass bags could cause loss of control of the machine.
- Do not mow up and down slopes.

Service

- Never store the machine or fuel container inside where there is an open flame, such as near a water heater or furnace.
- Keep nuts and bolts tight, especially the blade attachment bolts. Keep equipment in good condition.
- Never tamper with safety devices. Check safety systems for proper operation before each use.
- Use only genuine replacement parts to ensure that original standards are maintained.
- Check brake operation frequently. Adjust and service as required.
- Battery acid is poisonous and can cause burns. Avoid contact with skin, eyes and clothing. Protect your face, eyes and clothing when working with a battery.

- Battery gases can explode. Keep cigarettes, sparks and flames away from battery.
- Hydraulic fluid escaping under pressure can penetrate the skin and cause injury. Use cardboard or paper to find hydraulic leaks. Never use your hands.

Slope Chart

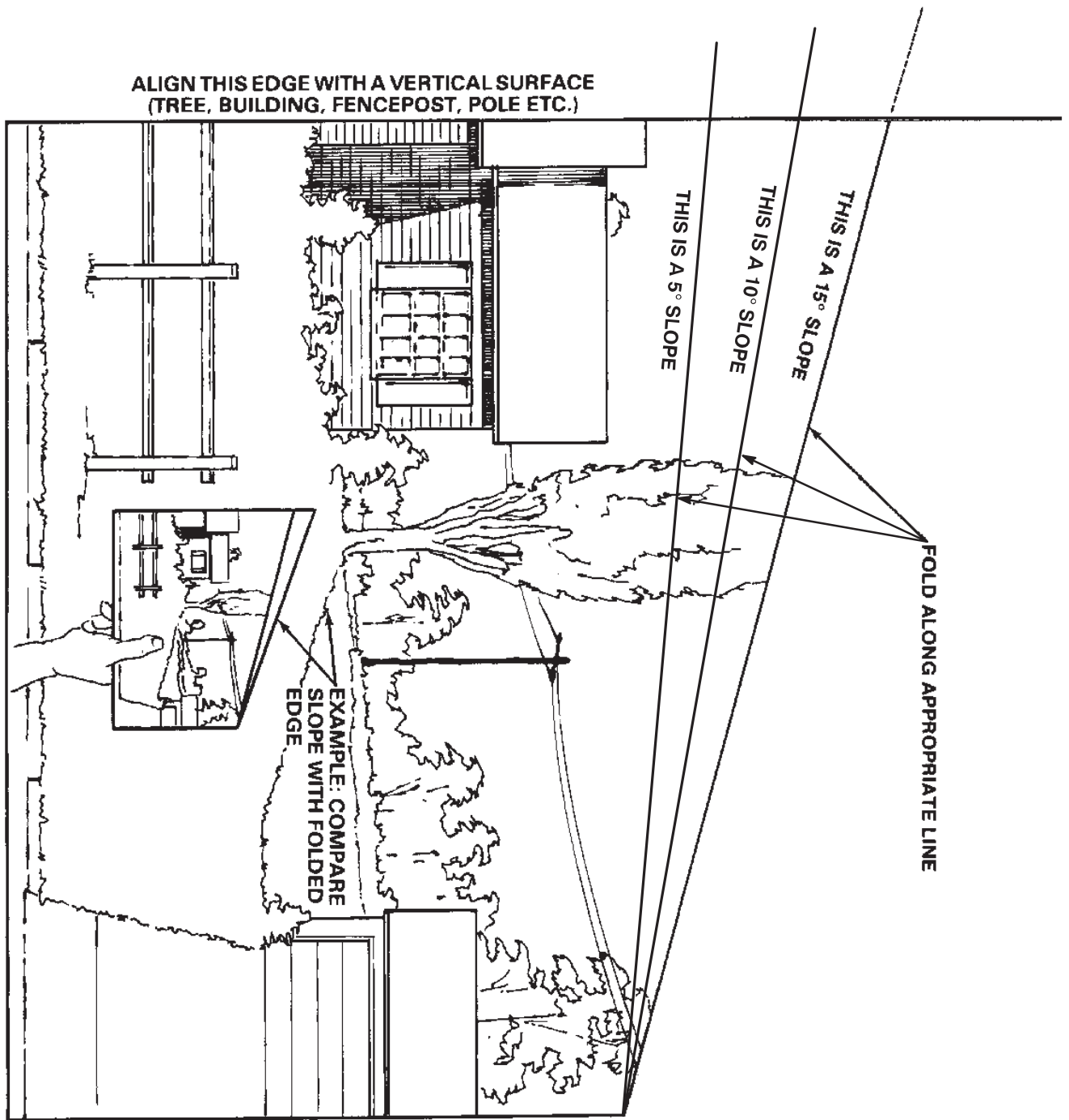

Safety and Instruction Decals



Safety decals and instructions are easily visible to the operator and are located near any area of potential danger. Replace any decal that is damaged or lost.



67-5360



63-8440



66-1340

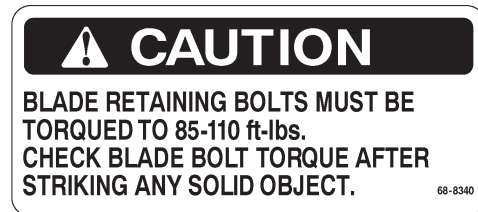

68-8340



43-8480



54-9220

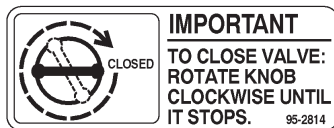

95-2814

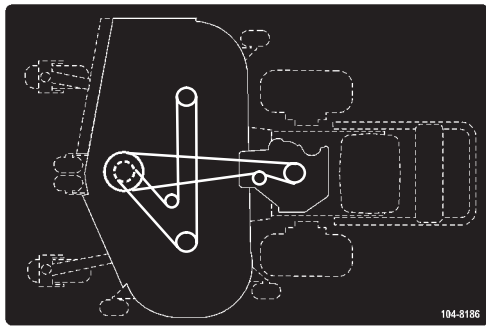

104-8186



104-8569



98-0776

ANTI-SCALP ROLLER ADJUSTMENT
 FOR MAXIMUM DECK FLOTATION, PLACE ROLLERS IN POSITIONS SHOWN.
 TURN ENGINE OFF BEFORE MAKING ROLLER ADJUSTMENTS.

- ————— 1.0"/25mm
- ————— 1.5"/38mm
- ————— 2.0"/51mm
- ————— 2.5"/63mm

105-0840

P
A
R
K
I
N
G
B
R
A
K
E

52-2010



82-2290



82-2280

USE REVERSE - TRACTION DRIVE BAR ONLY. DO NOT SHIFT UNDER LOAD. USE FORWARD - TRACTION DRIVE BAR ONLY.

R N 1 2 3 4 5

98-3256



98-4387

CHECK SERVICE REFERENCE AID

GREASE LUBE POINTS AT INTERVALS SHOWN. SEE ENGINE OPERATOR'S MANUAL FOR SERVICING ENGINE.

1 CHECK TIRE PRESSURE AT INTERVAL SHOWN. SEE OPERATOR'S MANUAL FOR ADDITIONAL DETAILS.

250 HOURS 40 HOURS AIR PRESSURE 12-14 PSI

40 HOURS AIR PRESSURE 12-14 PSI 400 HOURS

400 HOURS 8 HOURS 100 HOURS

40 HOURS

40 HOURS (44" DECK ONLY)

8 HOURS 40 HOURS AIR PRESSURE 20-24 PSI 8 HOURS

104-8175

CUTTING HEIGHT ADJUSTMENT

- POSITION ALL PINS IN SAME HEIGHT OF CUT HOLES
- TURN ENGINE OFF BEFORE ADJUSTING CUTTING HEIGHTS
- NOTE: HEIGHTS ARE BASED ON USING ONE FRONT SPACER AND TWO REAR SPACERS ON ADJUSTMENT PINS
- ADD ONE ADDITIONAL SPACER TO INCREASE CUTTING HEIGHTS 1/4 INCH
- NOTE: REFER TO OPERATOR'S MANUAL FOR ADDITIONAL HEIGHT OF CUT ADJUSTMENT.

REAR HEIGHT OF CUT ADJUSTMENT PIN

FRONT HEIGHT OF CUT ADJUSTMENT PIN

104-8171

104-8171

⚠ DANGER AVOID SERIOUS INJURY or DEATH:

- DO NOT MOW WHEN CHILDREN OR OTHERS ARE AROUND.
- DO NOT ALLOW OPERATION OF THE MACHINE BY UNTRAINED PERSONNEL.
- KEEP SAFETY DEVICES (GUARDS, SHIELDS, ETC.) IN PLACE & WORKING.
- REMOVE OBJECTS THAT COULD BE THROWN BY THE BLADE.
- READ THE OPERATOR'S MANUAL, FOR REPLACEMENT MANUAL, SEND MODEL AND SERIAL NUMBER TO: THE TORO CO., 9111 LYNDALE AVE. S., BLOOMINGTON, MN 55420-1196

105-0884

CHOKE

FAST

SLOW

ENGINE SPEED

IGNITION

BLADE ENGAGEMENT

104-8180

104-8180

Gasoline and Oil

Recommended Gasoline

Use **Unleaded** Regular Gasoline suitable for automotive use (85 pump octane minimum). Leaded regular gasoline may be used if unleaded regular is not available.

Important Never use methanol, gasoline containing methanol, or gasohol containing more than 10% ethanol because the fuel system could be damaged. Do not mix oil with gasoline.



Danger



In certain conditions, gasoline is extremely flammable and highly explosive. A fire or explosion from gasoline can burn you and others and can damage property.

- Fill the fuel tank outdoors, in an open area, when the engine is cold. Wipe up any gasoline that spills.
- Do not fill the fuel tank completely full. Add gasoline to the fuel tank until the level is 1/4" to 1/2" (6 mm to 13 mm) below the bottom of the filler neck. This empty space in the tank allows gasoline to expand.
- Never smoke when handling gasoline, and stay away from an open flame or where gasoline fumes may be ignited by a spark.
- Store gasoline in an approved container and keep it out of the reach of children. Never buy more than a 30-day supply of gasoline.
- Always place gasoline containers on the ground away from your vehicle before filling.
- Do not fill gasoline containers inside a vehicle or on a truck or trailer bed because interior carpets or plastic truck bed liners may insulate the container and slow the loss of any static charge.
- When practical, remove gas-powered equipment from the truck or trailer and refuel the equipment with its wheels on the ground.
- If this is not possible, then refuel such equipment on a truck or trailer from a portable container, rather than from a gasoline dispenser nozzle.
- If a gasoline dispenser nozzle must be used, keep the nozzle in contact with the rim of the fuel tank or container opening at all times until fueling is complete.



Warning



Gasoline is harmful or fatal if swallowed. Long-term exposure to vapors can cause serious injury and illness.

- Avoid prolonged breathing of vapors.
- Keep face away from nozzle and gas tank or conditioner opening.
- Keep gas away from eyes and skin.

Using Stabilizer/Conditioner

Use a fuel stabilizer/conditioner in the machine to provide the following benefits:

- Keeps gasoline fresh during storage of 90 days or less. For longer storage it is recommended that the fuel tank be drained.
- Cleans the engine while it runs
- Eliminates gum-like varnish buildup in the fuel system, which causes hard starting

Important Do not use fuel additives containing methanol or ethanol.

Add the correct amount of gas stabilizer/conditioner to the gas.

Note: A fuel stabilizer/conditioner is most effective when mixed with fresh gasoline. To minimize the chance of varnish deposits in the fuel system, use fuel stabilizer at all times.

Filling the Fuel Tank

1. Shut the engine off and chock or block tires.
2. Clean around the fuel tank cap and remove the cap. Add unleaded regular gasoline to fuel tank, until the level is 1/4 to 1/2 inch (6 mm to 13 mm) below the bottom of the filler neck. This space in the tank allows gasoline to expand. Do not fill the fuel tank completely full.
3. Install fuel tank cap securely. Wipe up any gasoline that may have spilled.

Check Engine Oil Level

Before you start the engine and use the machine, check the oil level in the engine crankcase; refer to Checking Oil Level, page 25.

Assembly

Note: Determine the left and right sides of the machine from the normal operating position.

Loose Parts

Note: Use the chart below to verify all parts have been shipped.

DESCRIPTION	QTY.	USE
Fuel tank	1	Installing the control panel and fuel tank
Control panel	1	
Bolt, 5/16 x 7/8 in.	2	
Lock washer, 5/16 in.	2	
Washer, 5/16 in.	4	
Spring	2	
Stud	2	
Hose clamp	1	
Shift lever	1	Installing the shift lever
Rubber seal	1	
Square hole washer	1	
Spring washer	1	
Locknut, 3/8 in.	1	
Upper handle	1	Installing the upper handle to frame
Flanged bolt 3/8 x 1 in.	4	
Flange nut 3/8 in.	4	
Clevis pin	1	Installing the control rods
Washer	1	
Hairpin cotter pin	2	
Hairpin cotter pin	2	Install hairpin cotter pins
Operator's Manual	1	Read before operating machine
Engine Operator's Manual	1	Read before operating machine
Parts Catalog	1	
Registration card	1	Fill out and return to Toro

Installing the Control Panel and Fuel Tank

Note: Hardware to install control panel and fuel tank is installed in the bottom of fuel tank.

1. Remove the bolts and nuts holding the control panel to the rear frame. Discard these nuts and bolts.
2. Slide the control panel over the shift lever and under the bottom of the rear frame (Fig. 2).

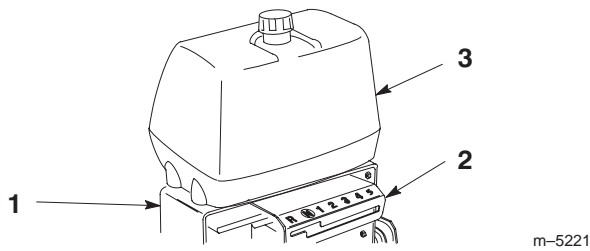

Figure 2

- | | |
|------------------|--------------|
| 1. Rear frame | 3. Fuel tank |
| 2. Control panel | |

- Align fuel tank with the top of the rear frame (Fig. 2).
- Secure the right side control panel and fuel tank to the rear frame (Fig. 3) with 2 bolts (5/16 x 7/8 in.), lock washers (5/16 in.) and washers (5/16 in.) (Fig. 3).
- Secure the left side control panel and fuel tank to the rear frame (Fig. 3) with 2 studs, washers (5/16 in.), springs and locknuts (5/16 in.) (Fig. 3).

Note: Tighten left side of control panel until it is completely tight and then unscrew locknut one full turn. This will allow the spring to work.

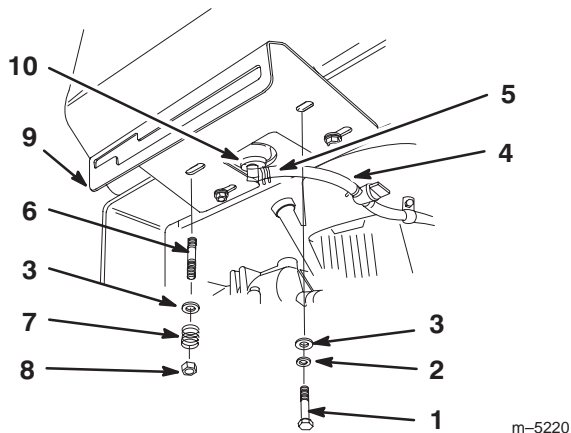

Figure 3

- | | |
|---------------------------|--------------------------|
| 1. Bolt, 5/16 x 7/8 in. | 6. Stud |
| 2. Lock washers, 5/16 in. | 7. Spring |
| 3. Washer, 5/16 in. | 8. Locknut |
| 4. Fuel line | 9. Control panel |
| 5. Hose clamp | 10. Fuel tank connection |

- Slide the hose clamp onto the fuel line (Fig. 3).
- Push the fuel line onto the fuel tank connection and secure it with a hose clamp (Fig. 3).

Installing the Shift Lever

- Remove the locknut (3/8 in.) and spring washer from the stud on top of the transmission.

Note: Do not remove rubber seal washer and square hole washer from transmission shaft.

- Slide shift lever through control panel and align mounting hole in lever with square on transmission shaft. Secure lever to transmission with previously removed spring washer and locknut (Fig. 4).
- Install the spring washer, dish down, and locknut (Fig. 4).
- Torque nut to 35 ft. lbs. (47 N•m).

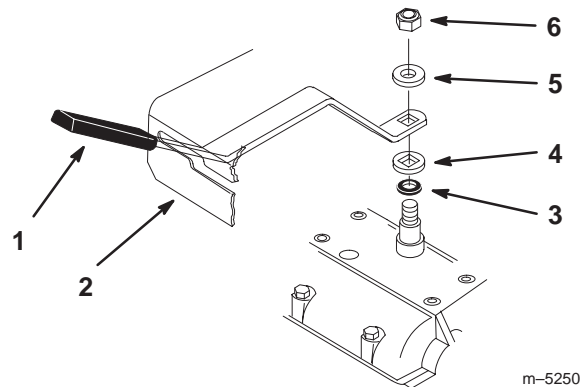

Figure 4

- | | |
|-----------------------|-----------------------|
| 1. Shift lever | 4. Square hole washer |
| 2. Control panel | 5. Spring washer |
| 3. Rubber seal washer | 6. Locknut, 3/8 in. |

- Shift lever to second gear and check alignment of lever in slot of shifter plate. The clearance between top and bottom of the shift lever should be equal (Fig. 5).
- If clearance is not correct, remove lever and bend it slightly to adjust.

Note: Do not bend lever while attached to transmission shaft or damage may occur.

- Shift lever to neutral and check alignment of lever in slot of shifter plate. The clearance on the sides of shift lever should be equal (Fig. 5).
- If clearance is not correct, loosen control panel and adjust it side-to-side. Tighten control panel.

Note: Tighten left side of control panel until it is completely tight and then unscrew locknut one full turn. This will allow the spring to work.

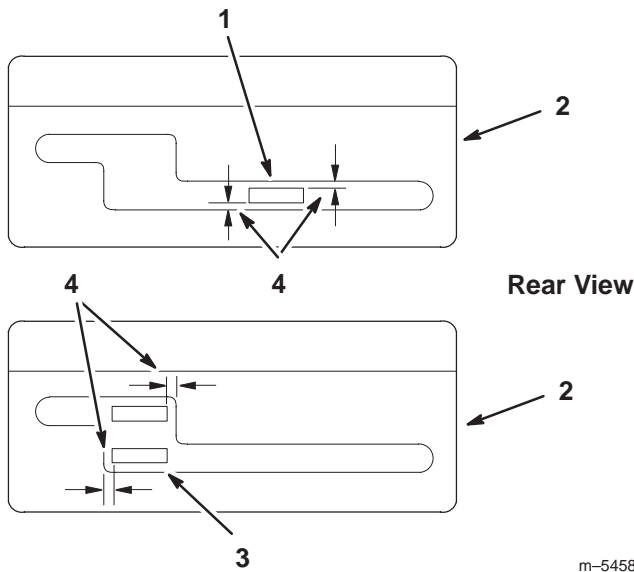

Figure 5

- | | |
|--------------------------|-------------------------|
| 1. Shift lever, 2nd gear | 3. Shift lever, neutral |
| 2. Control panel | 4. Equal distance |

m-5458

Installing the Upper Handle

1. Align upper handle with upper mounting holes in rear frame (Fig. 6).
2. Secure each upper mounting hole with a flange bolt (3/8 x 1 in.) and flange nut (Fig. 6). Torque bolts to 25 ft. lbs. (34 N.m).
3. Select high, medium or low position for the lower mounting hole (Fig. 6). This allows the upper handle to be adjusted to the user's height preference.
4. Secure each lower mounting hole with a flange bolt (3/8 x 1 in.) and flange nut (Fig. 6). Torque bolts to 25 ft. lbs. (34 N.m).

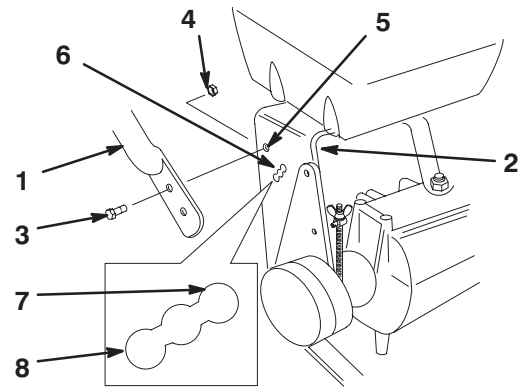

Figure 6

- | | |
|-----------------------------|-------------------------|
| 1. Upper handle | 5. Upper mounting hole |
| 2. Rear frame | 6. Lower mounting holes |
| 3. Flange bolt, 3/8 x 1 in. | 7. Low position |
| 4. Flange nut, 3/8 in. | 8. High position |

m-5317

Installing the Control Rods

1. Thread rod fittings equal distance onto each control rod. For a starting point, thread fittings on approximately 1-3/4 in. (44 mm) from the start of the threads (Fig. 7).
2. Slide clevis pins through rod fittings and mounting holes in idler brackets (from outside) (Fig. 7). Secure with washers and hairpin cotters (Fig. 7).

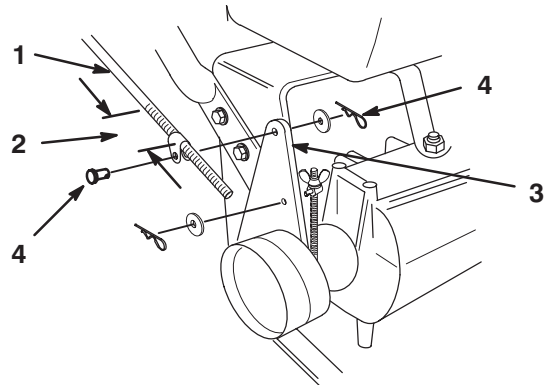

Figure 7

- | | |
|----------------------------|--|
| 1. Control rod and fitting | 4. Clevis pin, washer and hairpin cotter |
| 2. 1-3/4in. (44 mm) | |
| 3. Idler bracket | |

m-5316

3. Check the gap between upper control bar and fixed bar with wheel drive fully engaged. Gap should be approximately 1 to 1-1/4 in. (25 to 32 mm) (Fig. 8).

Note: The upper control bar and fixed bar must be parallel when in engaged, drive, relaxed and brake positions.

4. Check operation. If adjustment is required, remove hairpin cotter securing rod to upper control bar. Thread rod in or out of fitting for proper position and install into upper control bar with hairpin cotter.

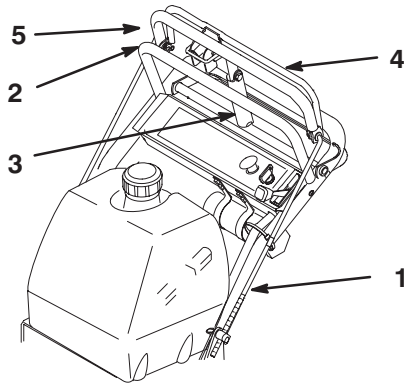

m-5190

Figure 8

- | | |
|------------------------|-------------------------------------|
| 1. Control rod | 4. Upper control bar |
| 2. Fixed control bar | 5. 1 to 1-1/4 in. gap (25 to 32 mm) |
| 3. Parking brake lever | |

5. Check parking brake adjustment. Brake rods should be adjusted so parking brake lever is tight when swung into position against the fixed bar while pulling back on upper control bar (Fig. 9).

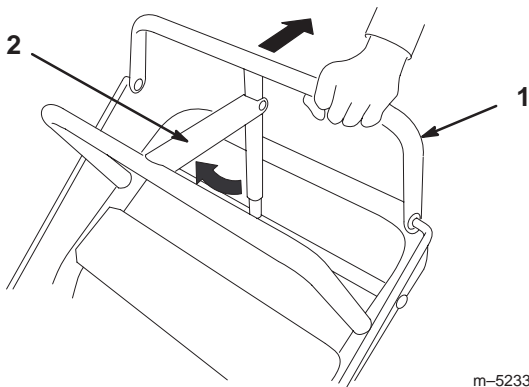

m-5233

Figure 9

- | | |
|----------------------|------------------------|
| 1. Upper control bar | 2. Parking brake lever |
|----------------------|------------------------|

6. If brake adjustment is required, remove hairpin cotter and washer securing brake rod fitting to idler bracket (Fig. 10).
7. Adjust wing nut up or down on brake rod and secure fitting to idler bracket (Fig. 10). Check adjustment and adjust if necessary.

Note: Make sure brake rod is installed in front (F) mounting hole in idler bracket.

8. Repeat procedure on opposite side if adjustment is required to keep control bar and fixed bar parallel.

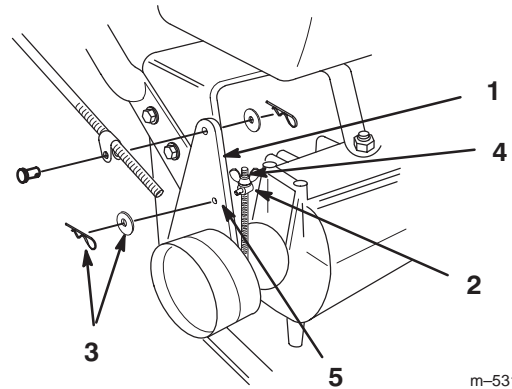

m-5316

Figure 10

- | | |
|------------------------------|-------------|
| 1. Idler bracket | 4. Wing nut |
| 2. Brake rod fitting | 5. Hole F |
| 3. Hairpin cotter and washer | |

Installing Hairpin Cotter Pins

Spare height-of-cut spacers may be stored on posts and retained by a hairpin cotter.

1. On opposite side of muffler, install extra hairpin cotter pins into front and rear height-of-cut pins (Fig. 11).

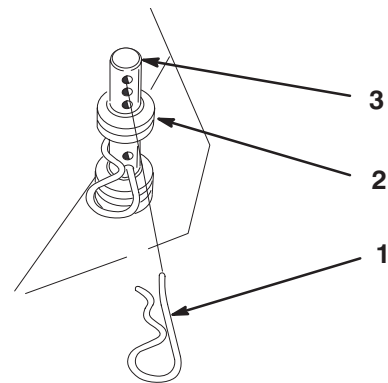

m-5314

Figure 11

- | | |
|-------------------|-----------------------|
| 1. Hairpin cotter | 3. Height-of-cut post |
| 2. Extra spacers | |

Operation

Note: Determine the left and right sides of the machine from the normal operating position.

Think Safety First

Carefully read all the safety instructions and decals in the safety section. Knowing this information could help you, your family, pets or bystanders avoid injury.

The use of protective equipment, such as but not limited to, for eyes, hearing, feet and head is recommended.

! **Caution** !

This machine produces sound levels in excess of 85dBA at the operators ear and can cause hearing loss through extended periods of exposure.

Wear hearing protection when operating this machine.

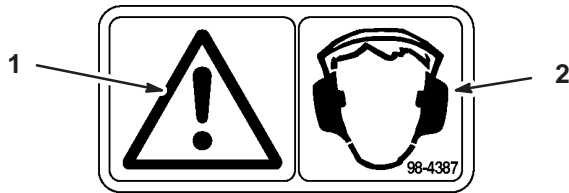

Figure 12

1. Caution 2. Wear hearing protection

Controls

Become familiar with all the controls (Fig. 13) before you start the engine and operate the machine.

Throttle Control – The throttle control has three positions: **Choke**, **Fast** and **Slow**.

Deck Engagement Control Bail – Control bail used in conjunction with deck engagement switch (PTO) to release blade brake and engage clutch to drive mower blades. Release bail to disengage mower blades.

Blade Control Switch (PTO) – Pull switch used in conjunction with control bail to release blade brake and engage clutch to drive mower blades.

Gear Shift Lever – Transmission has five forward speeds, neutral and reverse, and has an in-line shift pattern. Do not shift while unit is moving, as transmission damage may occur.

Upper Control Bar – Shift to desired gear and push forward on control bar to engage forward traction operation and pull back to brake. Pull right side of control bar to turn right and left side to turn left.

Lower Control Bar – Shift transmission to reverse and squeeze the lower control bar and handle together to engage rearward traction operation.

Parking Brake Lever – Pull back on upper control bar and swing brake lever up against the upper handle.

Ignition Switch – Key switch is used in conjunction with recoil starter. Switch has two positions: **RUN** and **OFF**.

Recoil Starter – Pull recoil Starter handle to start engine.

Fuel Shut-off Valve – (Under fuel tank) Close fuel shut-off valve when transporting or storing mower.

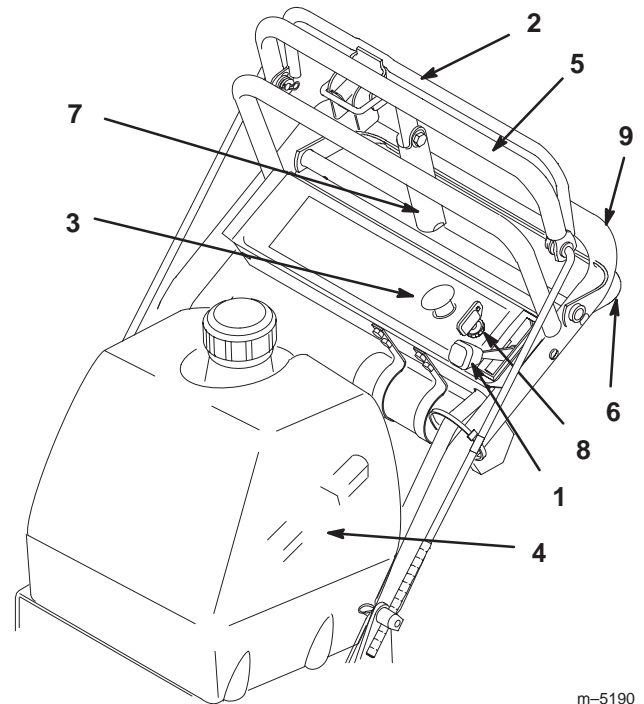

Figure 13

- | | |
|-------------------------------|------------------------|
| 1. Throttle control | 5. Upper control bar |
| 2. Blade control bail | 6. Lower control bar |
| 3. Blade control switch (PTO) | 7. Parking brake lever |
| 4. Gear shift lever | 8. Ignition switch |
| | 9. Handle |

Using the Parking Brake

Always set the parking brake when you stop the machine or leave it unattended.

Setting the Parking Brake

1. Pull the upper control bar (Fig. 14) rearward and hold it in this position.
2. Lift the parking brake lock (Fig. 14) up and gradually release the upper control bar. The brake lock should stay in the set (locked) position.

Releasing the Parking Brake

1. Pull rearward on the upper control bar (Fig. 14). Lower the parking brake lock to the released position.
2. Gradually release the upper control bar.

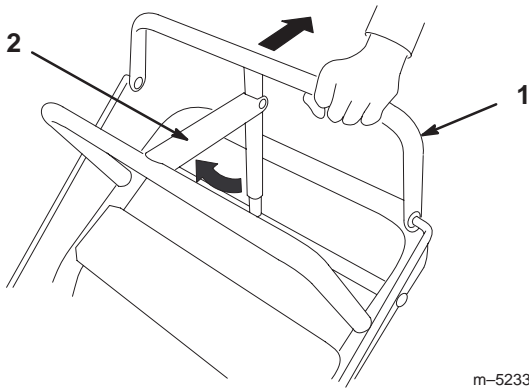

Figure 14

1. Upper control bar
2. Parking brake lever

Starting and Stopping the Engine

Starting Engine

1. Make sure spark plug wire(s) are installed on spark plug(s) and fuel valve is open.
2. Move the shift lever to neutral, set the parking brake and turn ignition key to RUN.
3. Move the throttle control to CHOKE position before starting a cold engine.

Note: A warm or hot engine usually does not require any choking. To start a warm engine, move throttle control to FAST position.

4. Grasp recoil starter handle firmly and pull out until positive engagement results; then pull handle vigorously to start engine and allow rope to recoil slowly.

Important Do not pull recoil rope to its limit or let go of the starter handle when rope is pulled out because rope may break or recoil assembly may be damaged.

Stopping Engine

1. Move the throttle lever to slow (Fig. 15).

2. Let engine idle for 30 to 60 seconds before turning the ignition key off.
3. Turn the ignition key to off (Fig. 15).

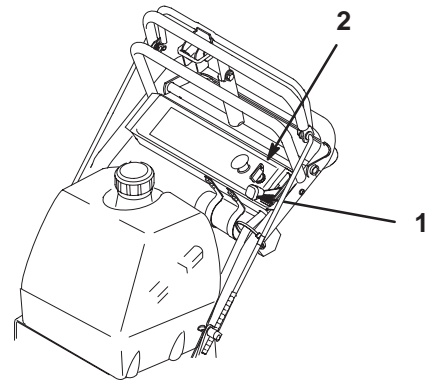

Figure 15

1. Throttle lever
2. Ignition key

4. Set the parking brake.
5. Pull wire off spark plug(s) to prevent possibility of accidental starting before storing machine.
6. Close fuel shut off valve before storing machine.

Important Make sure fuel shut off valve is closed before transporting or storing machine, as fuel leakage may occur.

Operating Mower Blade Control (PTO)

The blade control switch (PTO) in conjunction with the blade control bail engages and disengages power to the electric clutch and mower blades.

Engaging the Mower Blades (PTO)

1. Release the upper control bar to stop the machine (Fig. 16).
2. To engage blade, squeeze blade control bail against upper control bar (Fig. 16).
3. Pull blade switch (PTO) up and release. Hold blade control bail against control bar while operating.
4. Repeat procedure to engage mower blades if blade control bail is released.

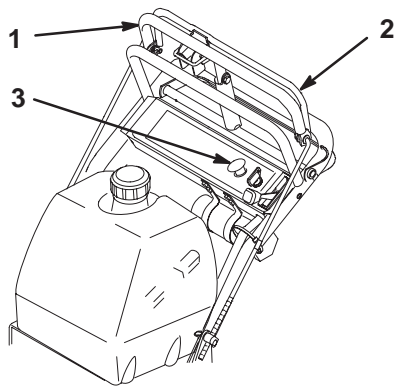

m-5190

Figure 16

- | | |
|-----------------------|-------------------------------|
| 1. Upper control bar | 3. Blade control switch (PTO) |
| 2. Blade control bail | |

Disengaging the Mower Blades (PTO)

1. Releasing blade control bail to disengage blades (Fig. 16).

The Safety Interlock System

⚠
Caution
⚠

If safety interlock switches are disconnected or damaged the machine could operate unexpectedly causing personal injury.

- Do not tamper with the interlock switches.
- Check the operation of the interlock switches daily and replace any damaged switches before operating the machine.

Understanding the Safety Interlock System

The safety interlock system is designed to prevent the mower blades from rotating unless:

- The control bail is depressed.
- The blade control switch (PTO) is pulled on.

The safety interlock system is designed to stop the mower blades if you released the blade control bail.

Testing the Safety Interlock System

Test the safety interlock system before you use the machine each time. If the safety system does not operate as described, have an Authorized Service Dealer repair the safety system immediately.

1. Set the parking brake and start the engine :refer to Starting and Stopping the Engine, page 18
2. Squeeze the blade control bail against upper control bar. **The blades should not rotate.**
3. Then continue holding the blade control bail and pull up on the blade control switch and release. The clutch should engage and the mower blades begin rotating.
4. Release the blade control bail. **The blades should stop rotating.**
5. With the engine running, pull up the blade control switch (PTO)and release without holding the blade control bail. **The blades should not rotate.**

Driving Forward or Backward

The throttle control regulates the engine speed as measured in rpm (revolutions per minute). Place the throttle control in the fast position for best performance.

Driving Forward

1. To go forward, move the shift lever to a forward gear.
2. Release the parking brake: refer to Releasing the Parking Brake, page 18.
3. Slowly press on the upper control bar to move forward (Fig. 17).

To go straight, apply equal pressure to both ends of the upper control bar (Fig. 17).

To turn, release pressure on the upper control bar side away from the direction you want to turn (Fig. 17).

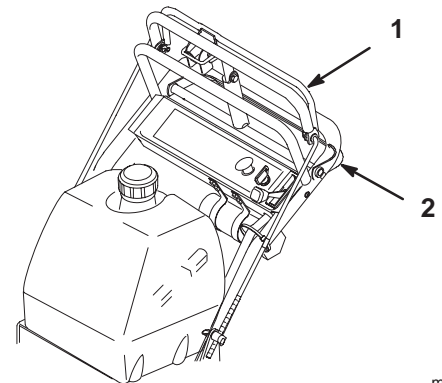

m-5190

Figure 17

- | | |
|----------------------|----------------------|
| 1. Upper control bar | 2. Lower control bar |
|----------------------|----------------------|

Driving Backward

1. To go backward, move the shift lever to reverse gear.

2. Release the parking brake: refer to Releasing the Parking Brake, page 18.
3. Slowly squeeze the lower control bar and handle together to move rearward (Fig. 17).

Operating Lower Control Bar

This procedure is for driving up a curb. This can be performed while driving forward or backward.

1. Disengage the mower blades.

! **Warning** !

A blade can be bent or damaged when driving up a curb. Pieces of blade that may be thrown could seriously injure or kill you or bystanders.

- **Do not run blades while driving up a curb forward or backward.**

2. Select first gear or reverse to drive machine.
3. Drive machine until drive wheels contact curb (Fig. 19).

Note: Both drive wheels should contact the curb and castor wheels straight.

4. At the same time engage lower control bar and lift up on handle (Fig. 18 and 19).

Note: Lifting up on handle will assist driving the machine up a curb and not spin the drive wheels.

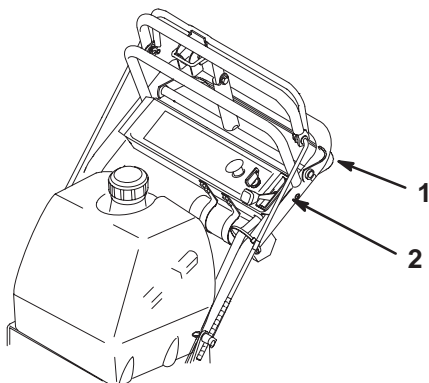
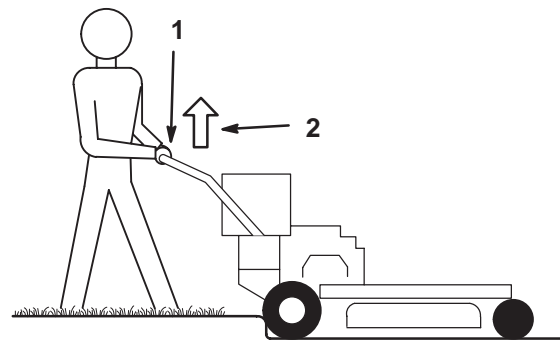

Figure 18

m-5190

1. Lower Control Bar (Engaged)
2. Handle



m-4185

Figure 19

1. Lower Control Bar engaged and mower in reverse.
2. Pull up to assist machine in reverse.

Stopping the Machine

To stop the machine, pull back on the upper control bar, release the blade control bail (PTO), and turn the ignition key to off. Also set the parking brake if you leave the machine unattended; refer to Setting the Parking Brake, page 17. Remember to remove the key from the ignition switch.

! **Caution** !

Children or bystanders may be injured if they move or attempt to operate the machine while it is unattended.

Always remove the ignition key and set the parking brake when leaving the machine unattended, even if just for a few minutes.

Transporting Machines

Use a heavy-duty trailer or truck to transport the machine. Ensure that the trailer or truck has all necessary lighting and marking as required by law. Please carefully read all the safety instructions. Knowing this information could help you, your family, pets or bystanders avoid injury.

To transport the machine:

- Lock brake and block wheels.
- Securely fasten the machine to the trailer or truck with straps, chains, cable, or ropes.
- Secure a trailer to towing vehicle with safety chains.

Using Side Discharge or Mulch Grass

This mower has a hinged grass deflector that disperses clippings to the side and down toward the turf.

⚠
Danger
⚠

Without the grass deflector, discharge cover, or complete grass catcher assembly mounted in place, you and others are exposed to blade contact and thrown debris. Contact with rotating mower blade(s) and thrown debris will cause injury or death.

- **Never remove the grass deflector from the mower because the grass deflector routes material down toward the turf. If the grass deflector is ever damaged, replace it immediately.**
- **Never put your hands or feet under the mower.**
- **Never try to clear discharge area or mower blades unless you release the bail and the power take off (PTO) is off. Rotate the ignition key to off. Also remove the key and pull the wire off the spark plug(s).**

Adjusting Height-of-Cut

The height-of-cut can be adjusted from 1 to 4-1/2 in. (25 to 115 mm) in 1/4 in. (6 mm) increments. Adjustment is done by relocating four hairpin cotter pins in different hole location and by adding or removing spacers.

Note: Rear height-of-cut pins need at least one spacer or damage can occur to bushing if none are used.

1. To adjust, remove hairpin cotter from height-of-cut post (Fig. 20).
2. Select hole in height-of-cut post corresponding to the height-of-cut desired (Fig. 20).
3. Lift on side of deck and remove hairpin cotter (Fig. 20).
4. Add or remove spacers if needed and then align holes and insert hairpin cotter (Fig. 20).

Note: Spare height-of-cut spacers may be stored on posts and retained by a hairpin cotter.

Important All four hairpin cotter pins must be in the same hole location and with the correct number of spacers for a level cut.

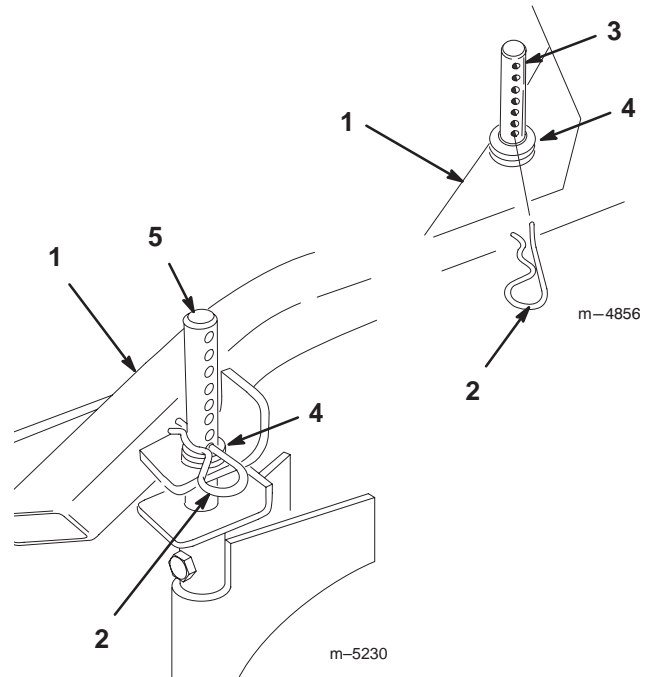

Figure 20

- | | |
|-----------------------------|----------------------------|
| 1. Carrier Frame | 4. Spacers |
| 2. Hairpin Cotter | 5. Back height-of-cut post |
| 3. Front height-of-cut post | |

Adjusting Gage Wheels

The gage wheels must be adjusted in the proper hole location for each height-of-cut position.

1. After adjusting height-of-cut remove nut and washer while holding stud with wrench (Fig. 21).

Note: Do not remove the wheel nut and washer (Fig. 21).

2. Select a hole position so the gage wheels are a minimum of 3/8 in. (10 mm) off the ground for the height-of-cut to be used (Fig. 21).
3. Reinstall the stud nut and washer (Fig. 21).
4. Repeat adjustment on other gage wheels.

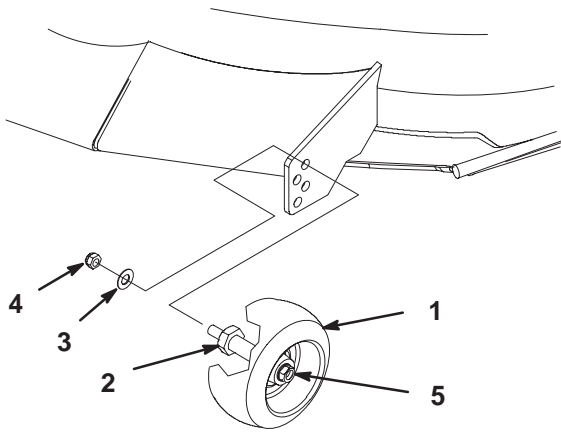

m-5201

Figure 21

- | | |
|---------------|--|
| 1. Gage Wheel | 4. Nut |
| 2. Stud | 5. Wheel nut and washer.
Do Not Remove. |
| 3. Washer | |

Adjusting Center Gage Wheels

The gage wheels must be adjusted in the proper hole location for each height-of-cut position.

1. After adjusting height-of-cut remove bolt, washers and nut (Fig. 22).
2. Select a hole position so the gage wheels are a minimum of 3/8 in. (10 mm) off the ground for the height-of-cut to be used (Fig. 22).
3. Reinstall the bolt, washers and nut (Fig. 22).

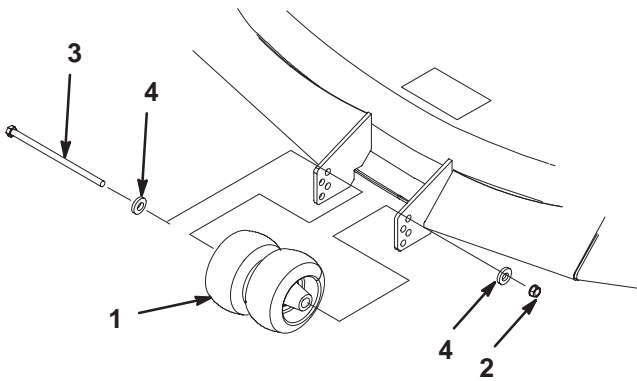

m-5200

Figure 22

- | | |
|-------------------------------------|-----------|
| 1. Center Gage Wheels and
Spacer | 3. Bolt |
| 2. Nut | 4. Washer |

Maintenance



Note: Determine the left and right sides of the machine from the normal operating position.

Recommended Maintenance Schedule

Maintenance Service Interval	Maintenance Procedure
Each Use	<ul style="list-style-type: none"> • Engine Oil—check level • Safety System—check • Brake—check • Engine—clean outside • Mower Housing—clean
After first 8 Hours	<ul style="list-style-type: none"> • Engine Oil—change
8 Hours	<ul style="list-style-type: none"> • Cutting Blades—check • Mower Housing—clean • Caster Wheels—grease
25 Hours	<ul style="list-style-type: none"> • Foam Air Cleaner—service¹
40 Hours	<ul style="list-style-type: none"> • PTO Belt Idler Arm—grease • Tires—check pressure
50 Hours	<ul style="list-style-type: none"> • Belts—check for wear/cracks • Paper Air Cleaner—clean¹
100 Hours	<ul style="list-style-type: none"> • Engine Oil—change¹ • Spark Plug(s)—check • Electric Clutch—adjust • Engine—clean outside
200 Hours	<ul style="list-style-type: none"> • Oil Filter—change (200 hours or every other oil change) • Fuel Filter—replace • Paper Air Cleaner—replace¹
250 Hours	<ul style="list-style-type: none"> • Transmission Couplings—grease¹
400 Hours	<ul style="list-style-type: none"> • Wheel Bearings—grease¹
At storage	<ul style="list-style-type: none"> • Chipped Surfaces—paint • Perform all maintenance procedures listed above before storage

¹More often in dusty, dirty conditions.

Important Refer to your engine operator's manual for additional maintenance procedures.

 Caution 
<p>If you leave the key in the ignition switch, someone could accidentally start the engine and seriously injure you or other bystanders.</p> <p>Remove the key from the ignition and disconnect the wire from the spark plug(s) before you do any maintenance. Set the wire aside so that it does not accidentally contact the spark plug.</p>

Servicing the Air Cleaner

Service Interval/Specification

Foam Element: Clean and re-oil after every 25 operating hours.

Paper Element: Clean after every 50 operating hours.
Replace after every 200 operating hours.

Note: Service the air cleaner more frequently (every few hours) if operating conditions are extremely dusty or sandy.

Removing the Foam and Paper Elements

1. Disengage the power take off (PTO), chock or block tires, and turn the ignition key to off. Remove the key.
2. Clean around the air cleaner to prevent dirt from getting into the engine and causing damage. Pull out on retaining latches and remove the air cleaner cover (Fig. 23).
3. Unscrew nut and remove the air cleaner assembly (Fig. 23).
4. Carefully pull the foam element off the paper element (Fig. 23).

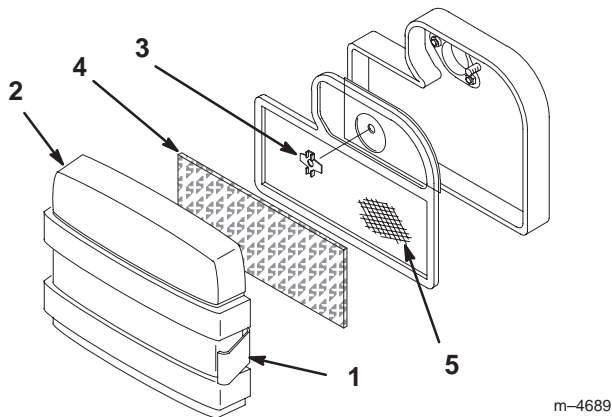

Figure 23

- | | |
|--------------------|------------------|
| 1. Retaining latch | 4. Foam element |
| 2. Cover | 5. Paper element |
| 3. Nut | |

Cleaning the Foam Element

1. Wash the foam element in liquid soap and warm water. When the element is clean, rinse it thoroughly.
2. Dry the element by squeezing it in a clean cloth.
3. Put one or two ounces of oil on the element (Fig. 24). Squeeze the element to distribute the oil.

Important Replace the foam element if it is torn or worn.

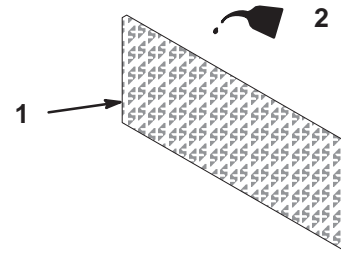

Figure 24

- | | |
|-----------------|--------|
| 1. Foam element | 2. Oil |
|-----------------|--------|

Cleaning the Paper Element

1. Lightly tap the element on a flat surface to remove dust and dirt (Fig. 25).
2. Inspect the element for tears, an oily film, and damage to the rubber seal.

Important Never clean the paper element with pressurized air or liquids, such as solvent, gas, or kerosene. Replace the paper element if it is damaged, defective, or cannot be cleaned thoroughly.

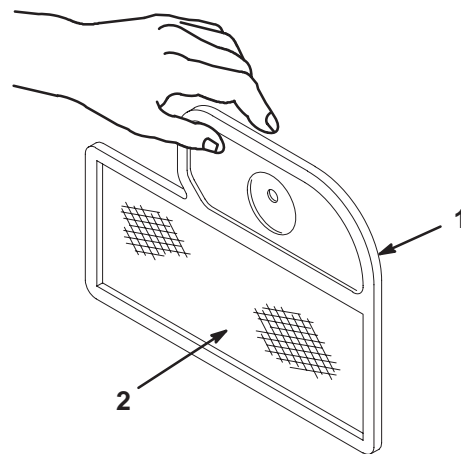

Figure 25

- | | |
|------------------|----------------|
| 1. Paper element | 2. Rubber seal |
|------------------|----------------|

Installing the Foam and Paper Elements

Important To prevent engine damage, always operate the engine with the complete foam and paper air cleaner assembly installed.

1. Carefully place the foam element onto the paper air cleaner element (Fig. 23).
2. Place the air cleaner assembly onto the air cleaner base (Fig. 23). Secure with nut.

3. Install the air cleaner cover and secure latches (Fig. 23).

Servicing the Engine Oil

Service Interval and Specification

Change oil:

- After the first 8 operating hours.
- After every 100 operating hours.

Note: Change oil more frequently when operating conditions are extremely dusty or sandy.

Oil Type: Detergent oil (API service SE, SF or SG)

Crankcase Capacity: with new filter, 57–1/2 oz. (1.7 l)

without new filter, 51 oz. (1.5 l)

Viscosity: See table below

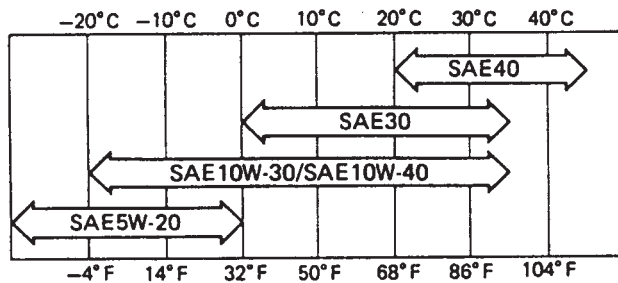

Checking Oil Level

1. Park the machine on a level surface, disengage the power take off (PTO), chock or block tires, and turn the ignition key to off. Remove the key.
2. Clean around the oil dipstick (Fig. 26) so dirt cannot fall into the filler hole and damage the engine.
3. Unscrew the oil dipstick and wipe the metal end clean (Fig. 26).
4. Thread the oil dipstick fully onto the filler tube (Fig. 26). Pull the dipstick out and look at the metal end. If oil level is low, slowly pour only enough oil into the filler tube to raise the level to the full mark.

Important Do not overfill the crankcase with oil because the engine may be damaged.

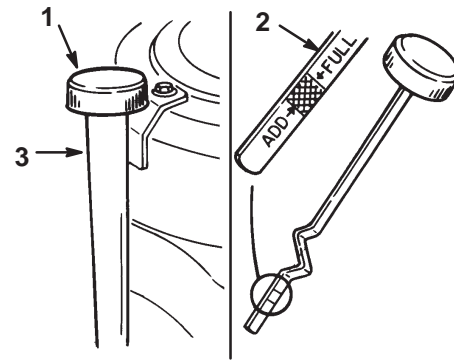

Figure 26

1. Oil dipstick
2. Metal end
3. Filler tube

Changing the Oil

1. Start the engine and let it run five minutes. This warms the oil so it drains better.
2. Park the machine so that the drain side is slightly lower than the opposite side to make sure the oil drains completely. Then disengage the power take off (PTO), chock or block tires, and turn the ignition key to off. Remove the key.
3. Place a pan below the oil drain. Remove the oil drain cap (Fig. 27).
4. When oil has drained completely, install the oil drain cap.

Note: Dispose of the used oil at a certified recycling center.

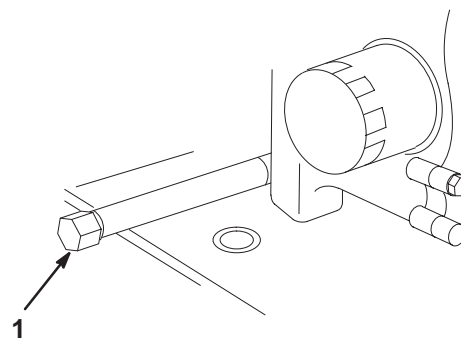

Figure 27

1. Oil drain cap

5. Slowly pour approximately 80% of the specified oil, page 25, into the filler tube (Fig. 26). Now check the oil level; refer to Checking Oil Level, page 25. Slowly add additional oil to bring to full mark on dipstick.

m-5207

Changing Oil Filter

Service Interval and Specification

Replace the oil filter every 200 hours or every other oil change.

Note: Change oil filter more frequently when operating conditions are extremely dusty or sandy.

1. Drain the oil from the engine; refer to Changing/Draining Oil, page 25.
2. Remove the old filter (Fig. 28).
3. Apply a thin coat of new oil to the rubber gasket on the replacement filter (Fig. 28).

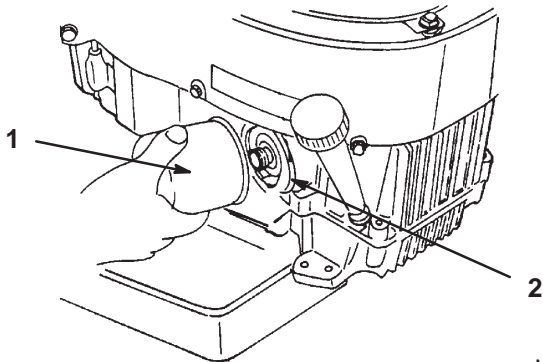

Figure 28

1. Oil filter
2. Adapter

4. Install the replacement oil filter to the filter adapter. Turn the oil filter clockwise until the rubber gasket contacts the filter adapter, then tighten the filter an additional 3/4 turn (Fig. 28).
5. Fill the crankcase with the proper type of new oil; refer to Engine Oil Service, page 25.

Servicing the Spark Plug

Service Interval and Specification

Check the spark plug(s) after every 100 operating hours. Make sure the air gap between the center and side electrodes is correct before installing the spark plug. Use a spark plug wrench for removing and installing the spark plug(s) and a gapping tool/feeler gauge to check and adjust the air gap. Install a new spark plug(s) if necessary.

Type: Champion® RCJ8Y or NGK® BPR4ES
Air Gap: 0.030 in. (.75 mm)

Removing the Spark Plug(s)

1. Disengage the power take off (PTO), chock or block tires, and turn the ignition key to off. Remove the key.
2. Pull the wire(s) off the spark plug(s) (Fig. 29). Now clean around the spark plug(s) to prevent dirt from falling into the engine and potentially causing damage.
3. Remove the spark plug(s).

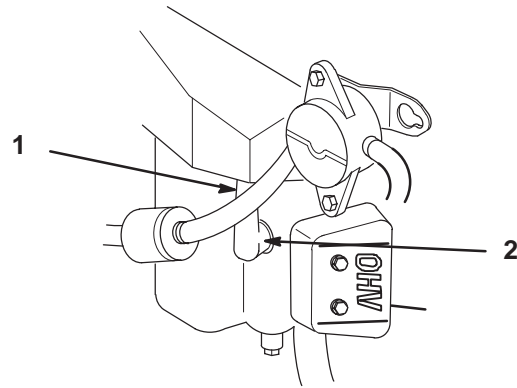

Figure 29

1. Spark plug wire installed
2. Spark plug

M-4294

Checking the Spark Plug

1. Remove spark plug.
 2. Look at the center of the spark plug(s) (Fig. 30). If you see light brown or gray on the insulator, the engine is operating properly. A black coating on the insulator usually means the air cleaner is dirty.
- Important** Never clean the spark plug(s). Always replace the spark plug(s) when it has: a black coating, worn electrodes, an oily film, or cracks.
3. Check the gap between the center and side electrodes (Fig. 30). Bend the side electrode (Fig. 30) if the gap is not correct.

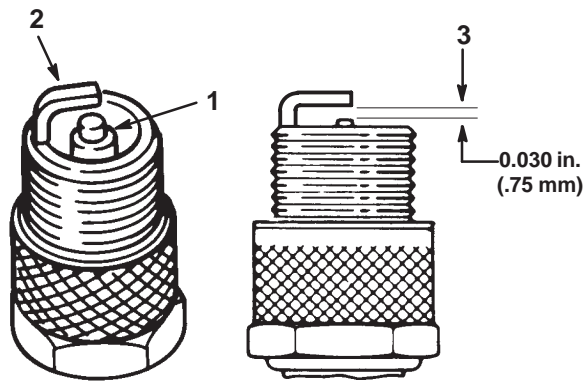

Figure 30

1. Center electrode insulator
2. Side electrode
3. Air gap (not to scale)

Installing the Spark Plug(s)

1. Install the spark plug(s). Make sure the air gap is set correctly.
2. Tighten the spark plug(s) to 11 ft-lb (15 N•m).
3. Push the wire(s) onto the spark plug(s) (Fig. 29).

Greasing and Lubrication

Service Interval/Specification

Refer to the CHECK SERVICE REFERENCE AID decal for location and interval of greasing and lubrication (Figure 31).

Grease with No. 2 general purpose lithium base or molybdenum base grease.

How to Grease

1. Disengage the power take off (PTO), chock or block tires, and turn the ignition key to off. Remove the key.
2. Clean the grease fittings with a rag. Make sure to scrape any paint off the front of the fitting(s).
3. Connect a grease gun to the fitting. Pump grease into the fittings.
4. Wipe up any excess grease.

Where to Add Grease

Lubricate the grease fittings as shown on the **Check Service Reference Aid** decal (Figure 31).

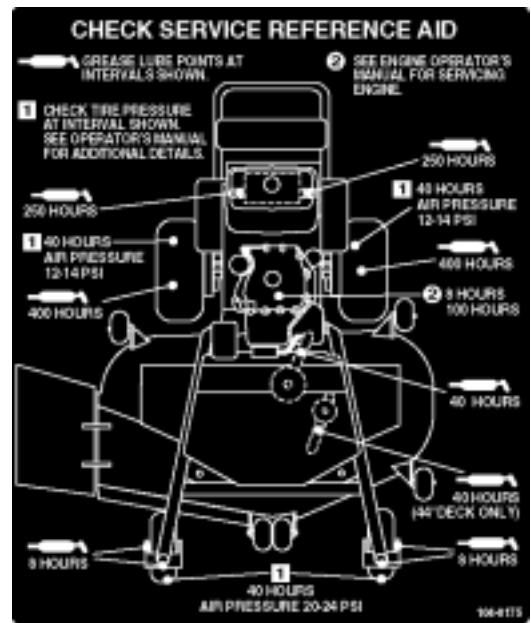

Figure 31

Lubricating the castor and wheel bearings

1. Lubricate the front wheel bearings and front spindles until grease begins to ooze out of the bearings (Fig. 32).
2. Remove rear wheel grease cap. Lubricate the rear wheel bearing (Fig. 32).

Note: Make sure the rear wheel grease caps are removed before lubricating rear wheels.

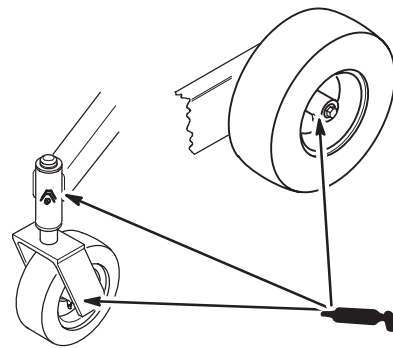

Figure 32

m-2147

Lubricating the transmission couplers

1. Lubricate the transmission couplers located in the back of the machine (Fig. 32).

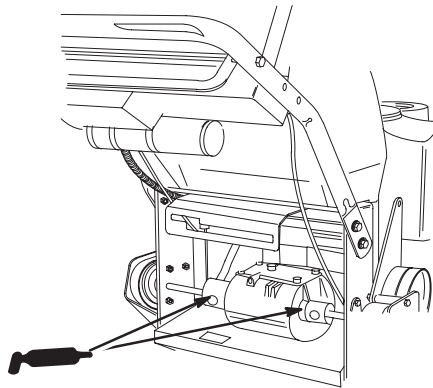

Figure 33

m-5191

Greasing the PTO Drive Belt Idler

1. Stop the engine, chock or block tires, remove the key and disconnect the spark plug wire(s) from the spark plug(s).
2. Grease the idler pulley pivot for the deck (Fig. 34).

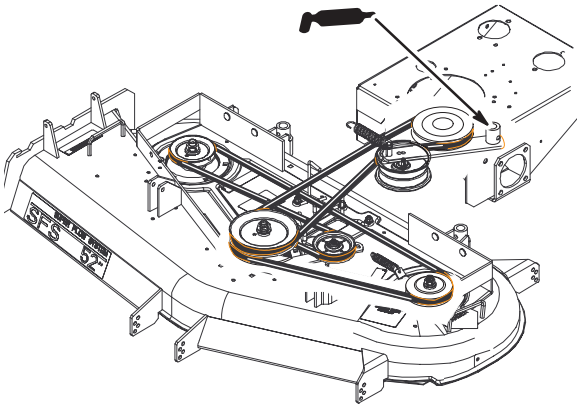

Figure 34

m-5196

Cleaning the Cooling System

Before each use, check and clean engine cooling system. Remove any build-up of grass, dirt or other debris from the cylinder and cylinder head cooling fins, air intake screen on flywheel end, and carburetor-governor levers and linkage. This will help insure adequate cooling and correct engine speed and will reduce the possibility of overheating and mechanical damage to the engine.

Checking Tire Pressure

Maintain the air pressure in the front and rear tires as specified. Check the pressure at the valve stem after every 40 operating hours or monthly, whichever occurs first (Fig. 35). Check the tires when they are cold to get the most accurate pressure reading.

Rear Tire Pressure: 12–14 psi (83–97 kPa)

Caster Tire Pressure: 20–24 psi (138–165 kPa)

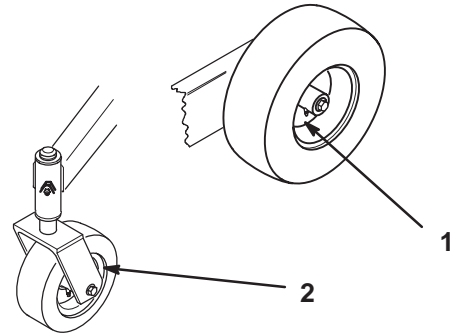

Figure 35

m-2147

1. Rear Tire

2. Caster tire

Servicing the Brake

Service Interval and Specification

Before each use, check brakes for proper operation.

Always set the parking brake when you stop the machine or leave it unattended. If the parking brake does not hold securely, an adjustment is required.

Checking the Brake

1. Park the machine on a level surface, disengage the power take off (PTO), set the parking brake, and turn the ignition key to off. Remove the key.
2. Set the parking brake (Fig. 36).

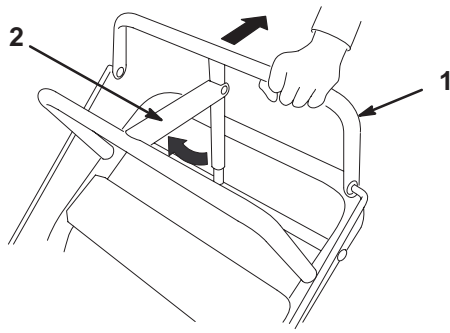

m-5233

Figure 36

1. Upper control bar
2. Parking brake lever (set position)

3. Rear wheels must lock when you try to push the machine forward. Adjustment is required if the wheels turn and do not lock; refer to Adjusting the Brake, page 29.
4. Release the brake and press upper control bar very lightly, approximately 1/2 in. (13 mm), wheels should rotate freely.
5. If both conditions are met no adjustment is required.

Adjusting the Brake

The brake lever is on the upper control bar (Fig. 13). If the parking brake does not hold securely, an adjustment is required.

1. Check the brake before you adjust it; refer to Checking the Brake, page 28.
2. Release the parking brake; refer to Releasing the Parking Brake, page 18.
3. To adjust the brake remove the cotter pin and washer from the brake lever (Fig. 37).
4. Rotate the trunnion so it smoothly slides into brake lever hole **F** (Fig. 37). Tighten wing nut.
5. Secure trunnion to brake lever with washer and cotter pin (Fig. 37).
6. Check the brake operation again; refer to Checking the Brake, page 28.

Important With the parking brake released, the rear wheels must rotate freely when you push the mower. If brake action and free wheel rotation cannot be achieved contact your service dealer immediately.

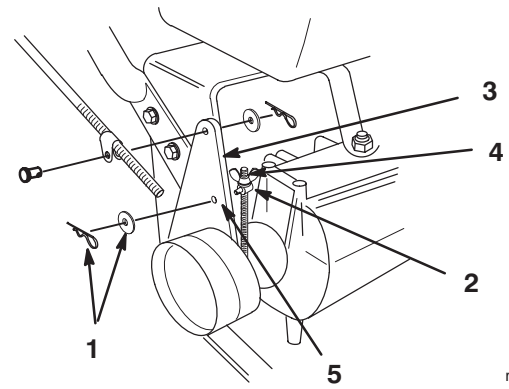

m-5316

Figure 37

1. Hairpin cotter and washer
2. Trunnion
3. Brake lever
4. Wing nut
5. Hole **F**

Adjusting the Electric Clutch

The clutch is adjustable to ensure proper engagement and proper braking. Check adjustment after every 100 hours of operation.

1. To adjust clutch, tighten or loosen lock nuts on flange studs (Fig. 38).
2. Check adjustment by inserting feeler gauge through slots next to studs (Fig. 38).
3. The proper disengaged clearance between the clutch plates is .012-.024 in. (0.30-0.60 mm). It will be necessary to check this clearance at each of the three slots to ensure the plates are parallel to each other.

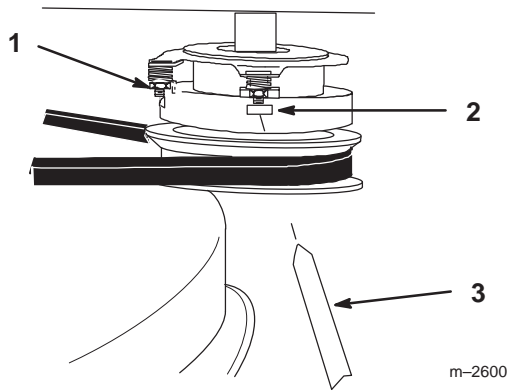

Figure 38

1. Adjusting nut
2. Slot
3. Feeler gauge

Servicing the Fuel Tank

! **Danger** !

In certain conditions, gasoline is extremely flammable and highly explosive. A fire or explosion from gasoline can burn you and others and can damage property.

- Drain gasoline from the fuel tank when the engine is cold. Do this outdoors in an open area. Wipe up any gasoline that spills.
- Never smoke when draining gasoline, and stay away from an open flame or where a spark may ignite the gasoline fumes.

Draining The Fuel Tank

1. Park the machine on a level surface, to assure fuel tank drains completely. Then disengage the power take off (PTO) and turn the ignition key to off. Remove the key.
2. Close fuel shut-off valve (Fig. 39).

Note: Remove fuel line from fuel valve that is closest to the engine.

3. Squeeze the ends of the hose clamp together and slide it away from valve (Fig. 39).
4. Pull the fuel line off the valve (Fig. 39). Open fuel shut-off valve and allow gasoline to drain into a gas can or drain pan.

Note: Now is the best time to install a new fuel filter because the fuel tank is empty. Refer to Replacing the Fuel Filter; page 30.

5. Install the fuel line onto the valve. Slide the hose clamp close to the valve to secure the fuel line.

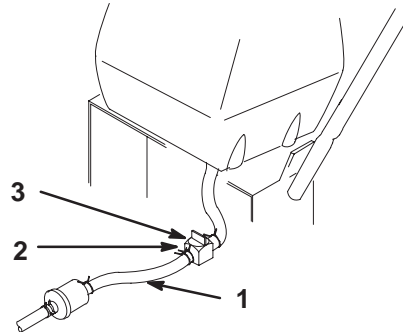

Figure 39

1. Fuel line
2. Hose clamp
3. Fuel shut off valve

Servicing the Fuel Filter

Service Interval and Specification

Replace the fuel filter after every 200 operating hours or yearly, whichever occurs first.

Replacing the Fuel Filter

Never install a dirty filter if it is removed from the fuel line.

Note: Note how the fuel filter is installed.

1. Disengage the power take off (PTO) and turn the ignition key to off. Remove the key.
2. Close fuel shut-off valve at fuel tank (Fig. 40).
3. Squeeze the ends of the hose clamps together and slide them away from the filter (Fig. 40).
4. Remove the filter from the fuel lines.
5. Install a new filter and move the hose clamps close to the filter.
6. Open fuel shut-off valve at fuel tank (Fig. 40).
7. Check for fuel leaks and repair if needed (Fig. 40).

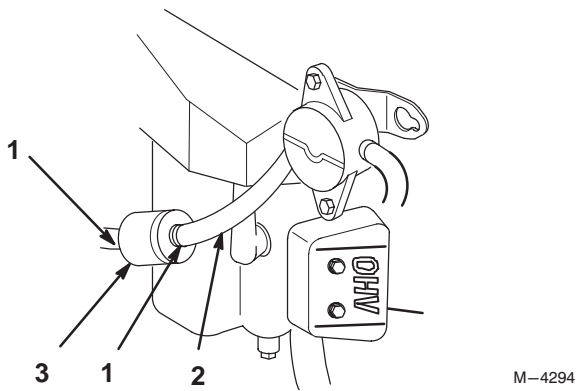

Figure 40

- 1. Hose clamp
- 2. Fuel line
- 3. Filter

Servicing the Fuse

The electrical system is protected by a fuse. It requires no maintenance, however, if the fuse blows check component/circuit for malfunction or short. To replace fuse pull out on the fuse to remove or replace it (Fig. 41).

Fuse: F1-7.5 amp, blade-type

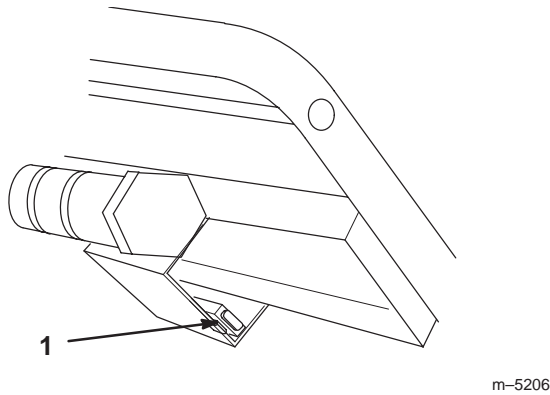

Figure 41

- 1. Fuse 7.5 amp

Servicing the Cutting Blade

To ensure a superior quality of cut, keep the blades sharp. For convenient sharpening and replacement, you may want to keep extra blades on hand.

⚠
Danger
⚠

A worn or damaged blade can break, and a piece of the blade could be thrown into the operator's or bystander's area, resulting in serious personal injury or death.

- Inspect the blade periodically for wear or damage.
- Replace a worn or damaged blade.

Before Inspecting or Servicing the Blades

Park the machine on a level surface, disengage the blade control (PTO) and chock or block tires. Turn the ignition key to off. Remove the key and disconnect the spark plug wire(s) from the spark plug(s).

Inspecting the Blades

1. Inspect the cutting edges (Fig 42). If the edges are not sharp or have nicks, remove and sharpen the blades. Refer to Sharpening the Blades on page 32.
2. Inspect the blades, especially the curved area (Fig. 42). If you notice any damage, wear, or a slot forming in this area (item 3 in Fig. 42), immediately install a new blade.

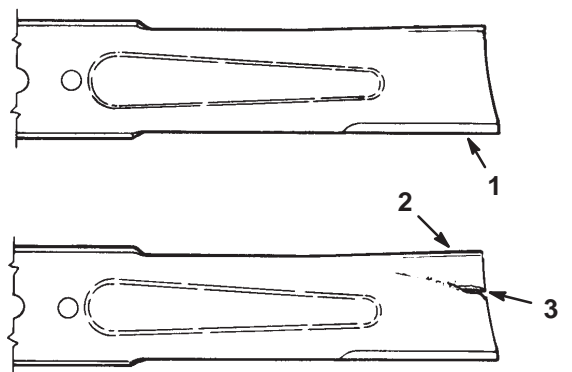

Figure 42

- 1. Cutting Edge
- 2. Curved Area
- 3. Wear/slot Forming

Checking for Bent Blades

1. Rotate the blades until the ends face forward and backward (Fig. 43). Measure from a level surface to the cutting edge, position A, of the blades (Fig. 44). Note this dimension.

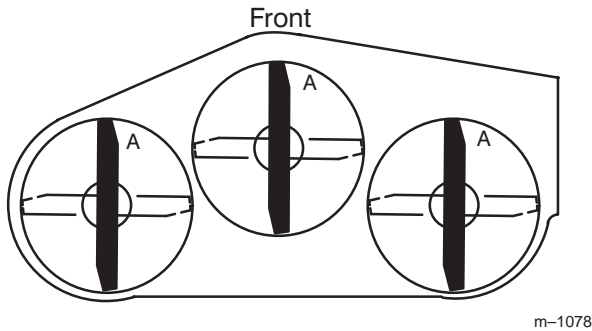
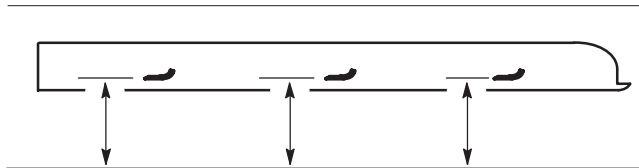

Figure 43

m-1078



MEASURE FROM
CUTTING EDGE TO A
LEVEL SURFACE

Figure 44

m-2539

2. Rotate the opposite ends of the blades forward.
3. Measure from a level surface to the cutting edge of the blades at the same position as in step 1 above. The difference between the dimensions obtained in steps 1 and 2 must not exceed 1/8 in. (3 mm). If this dimension exceeds 1/8 in. (3 mm), the blade is bent and must be replaced. Refer to Removing the Blades, and Installing the Blades on page 33.

Warning

A blade that is bent or damaged could break apart and could seriously injure or kill you or bystanders.

- Always replace bent or damaged blade with a new blade.
- Never file or create sharp notches in the edges or surfaces of blade.

Removing the Blades

Blades must be replaced if a solid object is hit, if the blade is out of balance or is bent. To ensure optimum performance and continued safety conformance of the

machine, use genuine TORO replacement blades. Replacement blades made by other manufacturers may result in non-conformance with safety standards.

1. Hold the blade end using a rag or thickly-padded glove. Remove the blade bolt, blade stiffener and blade from the spindle shaft (Fig. 45).

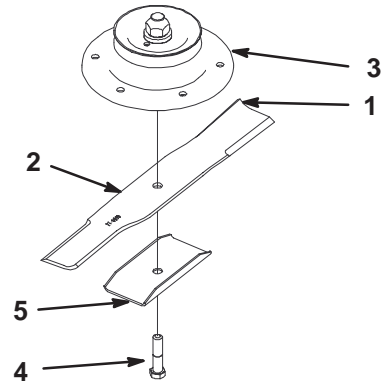

Figure 45

m-5227

- | | |
|-----------------------|--------------------|
| 1. Sail Area of Blade | 4. Blade Bolt |
| 2. Blade | 5. Blade stiffener |
| 3. Blade spindle | |

Sharpening the Blades

1. Use a file to sharpen the cutting edge at both ends of the blade (Fig. 46). Maintain the original angle. The blade retains its balance if the same amount of material is removed from both cutting edges.

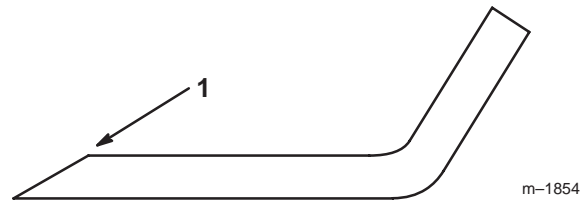

Figure 46

m-1854

1. Sharpen at original angle

2. Check the balance of the blade by putting it on a blade balancer (Fig. 47). If the blade stays in a horizontal position, the blade is balanced and can be used. If the blade is not balanced, file some metal off the end of the sail area only (Fig. 45). Repeat this procedure until the blade is balanced.

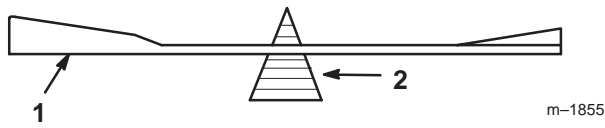

Figure 47

1. Blade
2. Balancer

Installing the Blades

1. Install the blade onto the spindle shaft (Fig. 45).

Important The sail part of the blade must be pointing upward, toward the inside of the mower to ensure proper cutting (Fig. 45).

2. Install the blade stiffener and blade bolt (Fig. 45).
Torque the blade bolt to 85–110 ft-lb (115–140 N•m).

Correcting Cutting Unit Mismatch

If one deck blade cuts lower than the other, correct as follows.

Note: Tire air pressure is critical in these procedures. Make sure all tires have correct pressure.

1. Stop the engine, remove the key and disconnect the spark plug wire(s) from the spark plug(s).
2. Adjust the tire pressure in all tires to specifications on page 28.
3. Check that the blades and spindle shafts are not bent. Refer to Checking for Bent Blades on page 32.
4. Set the height-of-cut to the 4 in. (102 mm) position. Refer to Adjusting the Height-Of-Cut in the Operation section.
5. Perform steps in the following sections Setting up the Frame, Checking Front-to-Rear Pitch and Checking Side-to-Side Leveling.

Setting Up the Frame

Checking Carrier Frame and Deck Alignment

1. Stop the engine, remove the key and disconnect the spark plug wire(s) from the spark plug(s).

2. Place a long straight edge on top of the engine deck as shown in figure 48.
3. At the carrier frame cross tube, measure location A height (Fig. 48). This measurement must be 2–13/16 in. (71 mm), plus or minus a 1/4 in. (6 mm).
4. If the height at location A is not correct, adjustment is needed.
5. Loosen the carrier frame mounting bolts on both sides of the machine (Fig. 48).
6. Align the carrier frame and engine deck to match 2–13/16 in. (71 mm), plus or minus a 1/4 in. (6 mm) at location A (Fig. 48).
7. Tighten the carrier frame mounting bolts on both sides of the machine.

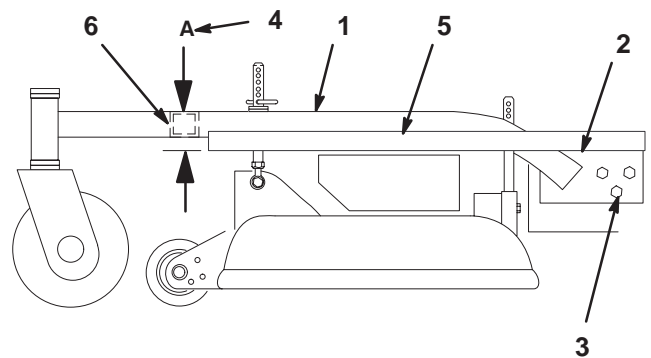

Figure 48

1. Carrier Frame
2. Top of engine deck
3. Carrier frame mounting bolts
4. Location A, 2–13/16 in. (71 mm)±1/4 in. (6 mm)
5. Straight edge
6. Carrier frame cross tube

Checking Engine Deck Height

1. Stop the engine, remove the key and disconnect the spark plug wire(s) from the spark plug(s).
2. Adjust the tire pressure in all tires to specifications on page 28.
3. Measure engine deck height at location A (Fig. 49).
4. Measure engine deck height at location B (Fig. 49).
5. If the height at location A and B are not the same, change tire pressure slightly to make them the same.

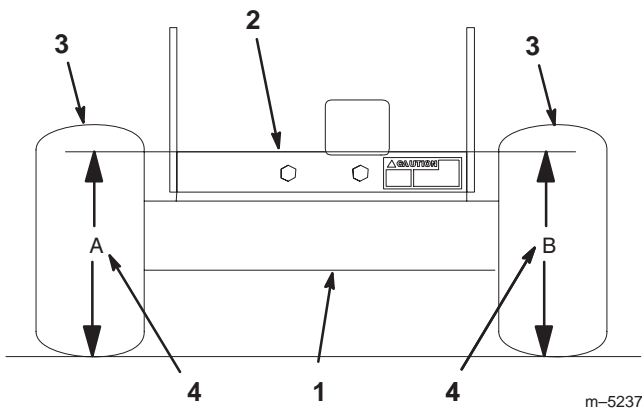

Figure 49

- | | |
|-------------------------|-------------------------------------|
| 1. Back view of machine | 4. Same height at locations A and B |
| 2. Top of engine deck | |
| 3. Tires | |

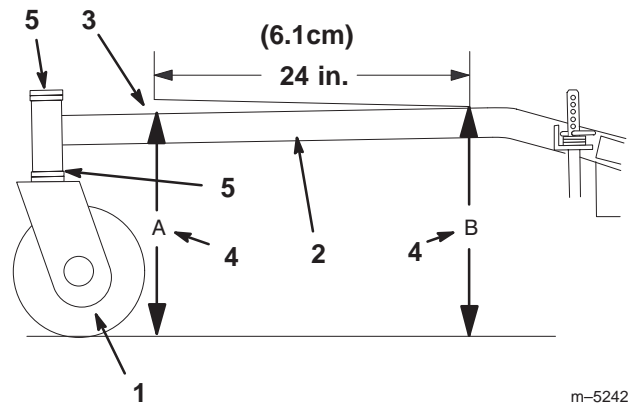

Figure 50

- | | |
|---|--------------------------------|
| 1. Caster Wheel | 4. Height at locations A and B |
| 2. Carrier Frame | 5. Caster spacers |
| 3. 1/4–3/8 in. (6 mm–10 mm) pitch over 24 in. (6.1 cm) length | |

Checking Carrier Frame Front-to-Rear Pitch

The carrier frame must have a pitch of a 1/4 in. (6 mm) over the length of 24 inches on the carrier frame (Fig. 50).

1. Measure out 24 inches (6.1 cm) on the carrier frame (Fig. 50).
2. Measure carrier frame height at location **A** (Fig. 50).
3. Measure carrier frame height at location **B** (Fig. 50).
4. The height at location **A** must be a 1/4–3/8 in. lower than location **B** (Fig. 50).
5. If the carrier frame is not correct, move caster spacers to make it a 1/4–3/8 in. (6–10 mm) pitch (Fig. 50). Move spacers from top or bottom to make the correct pitch.
6. The tire pressure may also be adjusted slightly to make a 1/4 in. (6 mm) pitch.

Checking Carrier Frame Side-to-Side

1. Stop the engine, remove the key and disconnect the spark plug wire(s) from the spark plug(s).
2. Adjust the tire pressure in all tires to specifications on page 28.
3. Measure carrier frame height at location **A** (Fig. 51).
4. Measure carrier frame height at location **B** (Fig. 51).
5. If the carrier frame height is not the same move spacers from top or bottom of caster wheel, to make it level. The tire pressure may also be adjusted slightly to make it level.

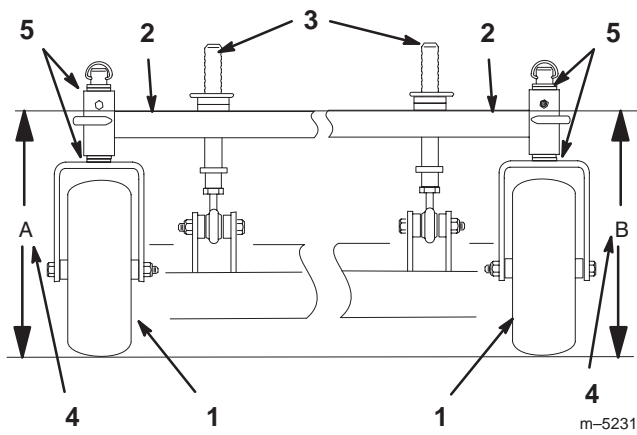

Figure 51

- | | |
|-----------------------------|-------------------------------------|
| 1. Caster Wheel | 4. Same height at locations A and B |
| 2. Carrier Frame | 5. Caster spacers |
| 3. Front height-of-cut pins | |

Checking the Deck Front-to-Rear Pitch

1. Check the tire pressure on both deck and traction unit.
2. Position one blade front-to-rear (Fig. 52). Measure at **C** and **D** locations (Fig. 52) from a level surface to the cutting edge of the blade tips (Fig. 53).
3. **The mower blade should be 1/4 in. (6 mm) lower in front C than in the rear D.** Rotate blades and repeat for other blades. If it is not correct, proceed to Changing the Deck Front-to-Rear Pitch.

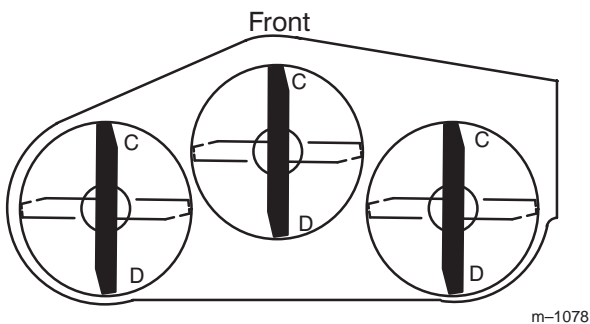
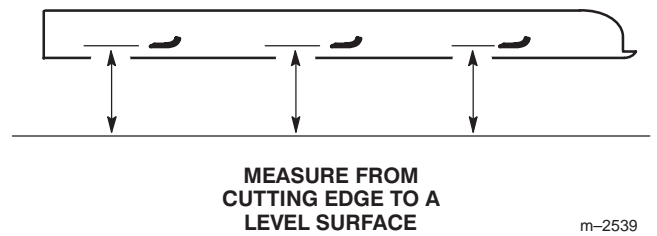

Figure 52



MEASURE FROM
CUTTING EDGE TO A
LEVEL SURFACE

m-2539

Figure 53

Changing the Deck Front-to-Rear Pitch

Changing the front-to-rear pitch is done by adjusting the front height-of-cut posts.

Changing the Deck Front-to-Rear Pitch by Adjusting Front Height-of-Cut Posts

1. To change the front-to-rear pitch, the front height-of-cut posts can be adjusted (Fig. 54).
2. To raise the front of the deck, loosen jam nut and rotate the front pin clockwise (Fig. 54).
3. To lower the front of the deck, loosen jam nut and rotate the front pin counter clockwise (Fig. 54).

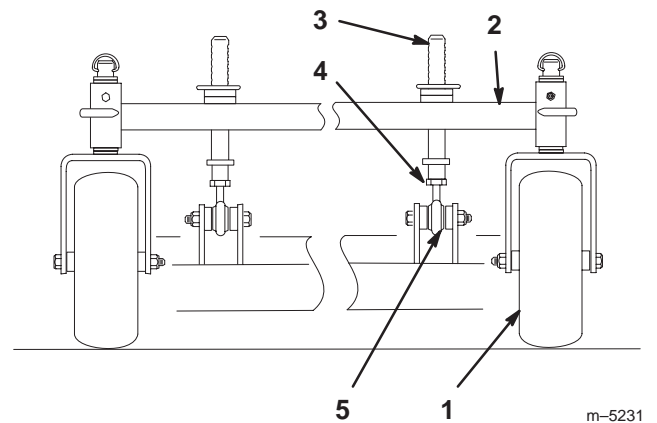

Figure 54

- | | |
|-----------------------------|---------------|
| 1. Caster Wheel | 4. Jam nut |
| 2. Carrier Frame | 5. Ball joint |
| 3. Front height-of-cut pins | |

4. Position the blades front-to-rear (Fig. 52). Measure at **C** and **D** locations (Fig. 52) from a level surface to the cutting edge of the blades (Fig. 53).
5. Check the side-to-side leveling of the cutting unit.

Checking the Deck Side-to-Side Level

1. Check the tire pressure on both deck and traction unit.
2. Position the blades side-to-side (Fig. 55). Measure at **A** and **B** locations (Fig. 55) from a level surface to the cutting edge of blade tips (Fig. 56).
3. The difference between measurements **A** and **B** should be no more than 1/4 in. (6 mm).

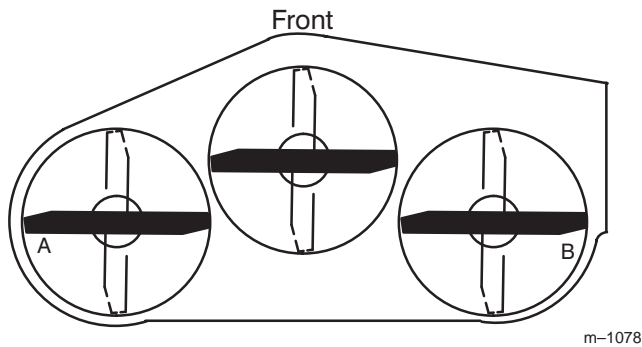
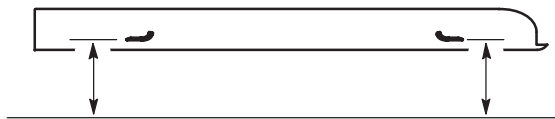

Figure 55



MEASURE FROM
CUTTING EDGE TO
A LEVEL SURFACE

Figure 56

m-2550

Matching Height of Cut

1. Check the tire pressure on both deck and traction unit.
2. Set the height-of-cut to the 4 in. (102 mm) position following the height-of-cut decal.
3. With the machine on level surface, position one blade front-to-rear (Fig. 57). Measure at **A** and from level surface to the cutting edge of the blade tips (Fig. 58).
4. The measurement should be 4 in. (102 mm).

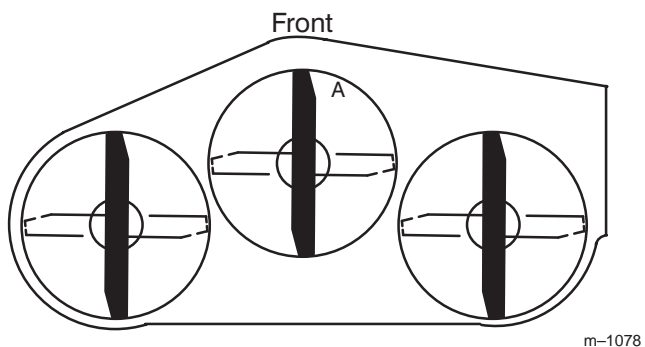
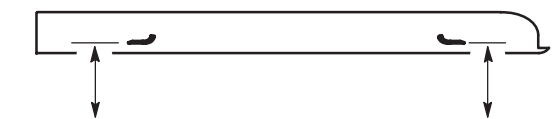

Figure 57



MEASURE FROM
CUTTING EDGE TO
A LEVEL SURFACE

Figure 58

m-2550

Changing the Side-to-Side Level

Changing the side-to-side leveling is done by adjusting tire pressure.

Changing the Side-to-Side Leveling with Tire Pressure

1. Change the tire pressure on both deck and traction unit. Do this to the corresponding side that needs adjustment.
2. Recheck the front-to-rear pitch and side to side leveling of the cutting unit.

5. If it does not measure correctly, add air pressure in rear tires to raise height-of-cut
6. If it does not measure correctly, decrease air pressure in rear tires to lower height-of-cut.
7. Check carrier frame front-to-rear pitch.

Replacing the Drive Belt

Service Interval/Specification

Check all belts after every 50 operating hours or monthly, whichever occurs first. Look for dirt, wear, cracks and signs of overheating.

1. Remove top capscrew securing idler support and idler bracket to rear frame (Fig. 59).
2. Loosen bottom two mounting screws enough to allow belt to pass between drive pulley and idler support (Fig. 59).

3. Raise wheel off ground enough to allow belt removal.

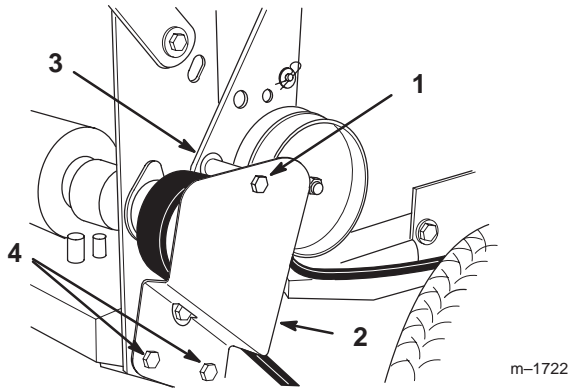

Figure 59

- | | |
|------------------|--------------------|
| 1. Top capscrew | 3. Idler support |
| 2. Idler bracket | 4. Bottom capscrew |

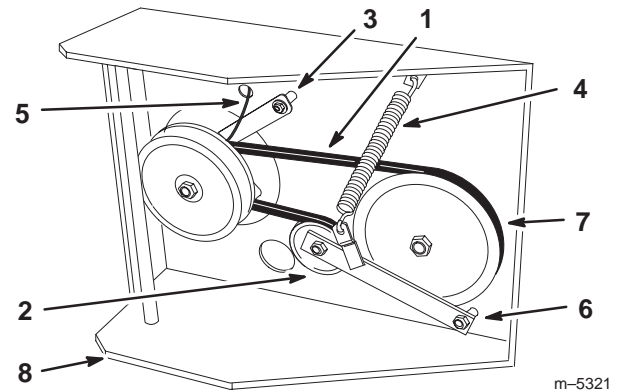

Figure 60

- | | |
|--------------------|--------------------------|
| 1. Traction belt | 5. Clutch wire connector |
| 2. Idler pulley | 6. Pivot bolt |
| 3. Clutch retainer | 7. Drive pulley |
| 4. Tension spring | 8. Engine deck |

Replacing the Traction Belt

1. Raise the front of the machine and hold with jack stands.
2. Disconnect clutch wire connector from wire harness.
3. Remove PTO drive belt. Refer to Replacing the PTO Drive Belt on page 38.
4. Remove clutch retainer from the engine deck (Fig. 60).
5. Unhook tension spring from side of frame (Fig. 60).
6. Loosen pivot bolt enough to remove traction belt from the drive pulley and clutch.
7. Install new belt around clutch and drive pulley.
8. Torque pivot bolt to 35-40 ft. lb. (47-54 N.m). Install tension spring between idler arm and frame bracket (Fig. 60).
9. Install clutch retainer to the engine deck (Fig. 60).
10. Connect clutch wire connector to wire harness.
11. Install PTO drive belt.

Replacing the Deck Belt

Squealing when the belt is rotating, blades slipping when cutting grass, frayed belt edges, burn marks and cracks are signs of a worn deck belt. Replace the deck belt if any of these conditions are evident.

1. Stop the engine, remove the key and disconnect the spark plug wire(s) from the spark plug(s).
2. Remove the knobs holding the carrier frame cover and remove the carrier frame cover.
3. Remove the knobs holding the belt covers to the cutting unit and remove the belt covers.
4. Remove the PTO drive belt. Refer to Replacing the PTO Drive Belt on page 38.
5. Disconnect the idler arm spring to relieve tension on the idler arm and idler pulley, then remove the worn deck belt (Fig. 61).
6. Install the new deck belt around the two outside spindle pulleys, the idler pulley, and in the lower groove of the center spindle pulley (Fig. 61).
7. Connect the idler arm spring (Fig. 61).
8. Reinstall the PTO drive belt. Refer to Replacing the PTO Drive Belt page 38.
9. Reinstall the deck covers onto the cutting unit, then reinstall and tighten the knobs.

10. Install the carrier frame cover onto the cutting unit, then install and tighten the hand knobs.
11. Adjust deck belt guide an 1/8 in. (3 mm) from belt (Fig. 61).

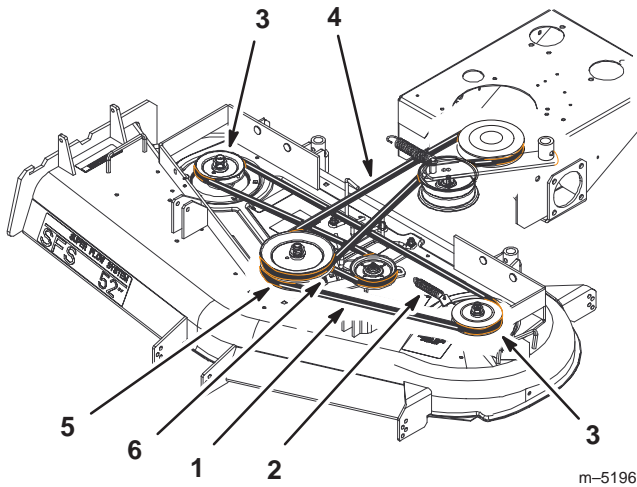

Figure 61

- | | |
|---------------------|--------------------------|
| 1. Deck belt | 4. PTO Drive belt |
| 2. Idler arm spring | 5. Center spindle pulley |
| 3. Outside pulley | 6. Belt guide |

Replacing the PTO Drive Belt

Squealing when the belt is rotating, blades slipping when cutting grass, frayed belt edges, burn marks and cracks are signs of a worn drive belt. Replace the drive belt if any of these conditions are evident.

1. Stop the engine, remove the key and disconnect the spark plug wire(s) from the spark plug(s).
2. Remove the knobs holding the carrier frame cover and remove the carrier frame cover.
3. Remove the knobs holding the belt covers to the top of the cutting unit and remove the belt covers.
4. Remove the heat shield from the the engine deck and carrier frame.
5. Remove the idler spring from idler arm. Remove the drive belt from the PTO engagement pulley and the center spindle pulley (Fig. 62).
6. Remove the worn drive belt (Fig. 62).
7. Install the new drive belt onto the PTO engagement pulley and the top groove of the center spindle pulley (Fig. 62).

8. Install belt onto idler pulley and then install idler spring (Fig. 62).
9. Adjust PTO drive belt guides an 1/8 in. (3 mm) from belt (Fig. 62).
10. install the heat shield to the the engine deck and carrier frame.
11. Install the belt covers onto the cutting unit, then install and tighten the knobs.
12. Install the carrier frame cover onto the cutting unit, then install and tighten the hand knobs.

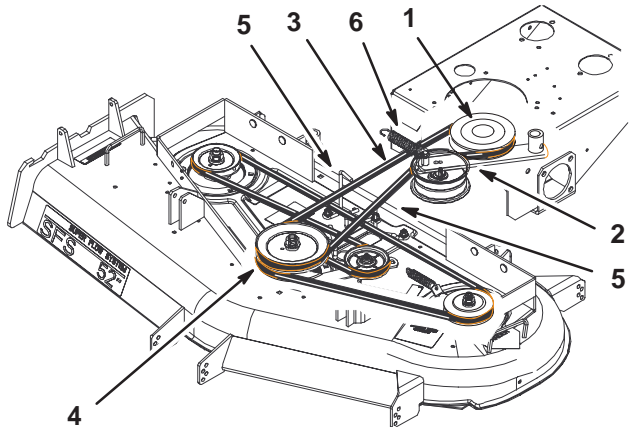

Figure 62

- | | |
|--------------------------|--------------------------|
| 1. PTO engagement pulley | 4. Center Spindle Pulley |
| 2. Drive belt idler | 5. PTO Drive belt guide |
| 3. PTO drive Belt | 6. Idler Spring |

Replacing the Caster Wheel Fork Bushings

The caster wheel forks are mounted in bushings pressed into the top and bottom of the carrier frame mounting tubes. To check the bushings, move the caster forks back and forth and side-to-side. If a caster fork is loose, the bushings are worn and must be replaced.

1. Raise the cutting unit so the caster wheels are off the floor, then block up the front of the mower with jack stands.
2. Remove the locking pin and spacer(s) from the top of the caster wheel fork (Fig. 63).

3. Pull the caster wheel fork out of the mounting tube, leaving the spacer(s) on the bottom of the fork. Remember the location of the spacers on each fork to ensure correct installation, and to maintain a level deck.

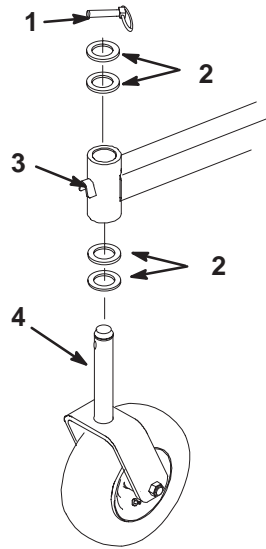

m-5198

Figure 63

- | | |
|---------------------------------|--------------------------------|
| 1. Locking Pin | 3. Carrier Frame Mounting Tube |
| 2. Spacers (locate as required) | 4. Caster Wheel Fork |

4. Insert a pin punch into the mounting tube and carefully drive out the bushings (Fig. 64). Clean the inside of the mounting tube.
5. Grease the inside and outside of the new bushings. Use a hammer and flat plate to carefully drive the bushings into the mounting tube.
6. Inspect the caster wheel fork for wear and replace if necessary (Fig. 63).
7. Slide the caster wheel fork through the bushings in the mounting tube. Replace the spacer(s) onto the fork and secure with the retaining ring (Fig 63).

Important The inside diameter of the bushings may collapse slightly when installed. If the caster wheel fork does not slide into the new bushings, ream both bushings to an inside diameter of 1.126 in. (28.6 mm).

8. Grease the fitting on the carrier frame mounting tube using No. 2 general purpose lithium base or molybdenum base grease.

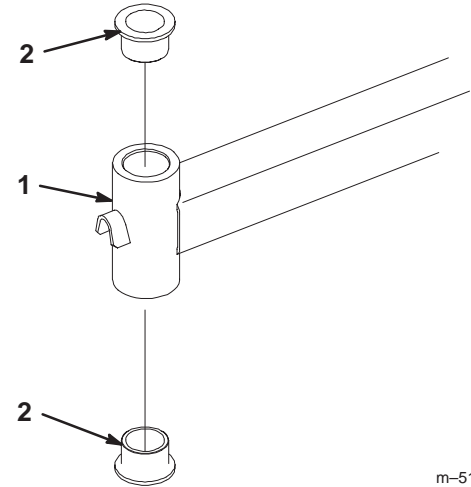

m-5197

Figure 64

- | | |
|--------------------------------|------------|
| 1. Carrier Frame Mounting Tube | 2. Bushing |
|--------------------------------|------------|

Caster Wheel and Bearings Service

The caster wheels rotate on a roller bearing supported by a spanner bushing. If the bearing is kept well lubricated, wear will be minimal. Failure to keep the bearing well lubricated will cause rapid wear. A wobbly caster wheel usually indicates a worn bearing.

1. Remove the locknut and wheel bolt holding the caster wheel to the caster fork (Fig. 65).
2. Remove one bushing, then pull the spanner bushing and roller bearing out of the wheel hub (Fig. 65).
3. Remove the other bushing from the wheel hub and clean any grease and dirt from the wheel hub (Fig. 65).

4. Inspect the roller bearing, bushings, spanner bushing and inside of the wheel hub for wear. Replace any defective or worn parts (Fig. 65).

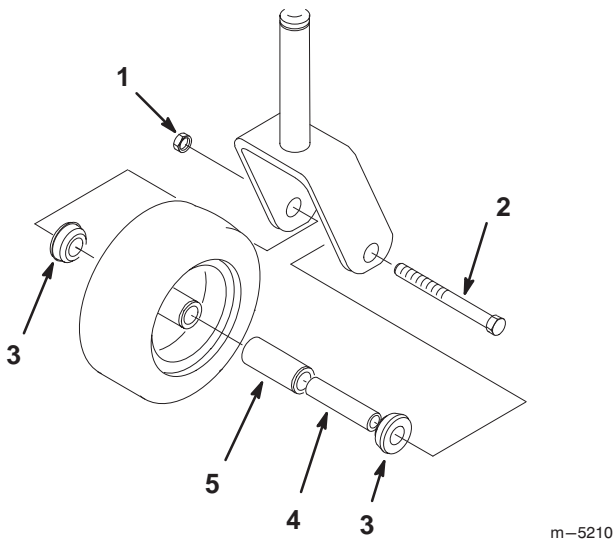

Figure 65

- | | |
|---------------|--------------------|
| 1. Locknut | 4. Spanner Bushing |
| 2. Wheel Bolt | 5. Roller Bearing |
| 3. Bushing | |

5. To assemble, place one (1) bushing into the wheel hub. Grease the roller bearing and spanner bushing and slide them into the wheel hub. Place the second bushing into the wheel hub (Fig. 65).
6. Install the caster wheel into the caster fork and secure with the wheel bolt and locknut. Tighten the locknut until the spanner bushing bottoms against the inside of the caster forks (Fig. 65).
7. Grease the fitting on the caster wheel.

Replacing the Grass Deflector



Warning



An uncovered discharge opening could allow the lawn mower to throw objects in the operator's or bystander's direction and result in serious injury. Also, contact with the blade could occur.

Never operate the lawn mower unless you install a cover plate, a mulch plate, or a grass chute and catcher.

1. Remove the locknut, bolt, spring and spacer holding the deflector to the pivot brackets (Fig. 66). Remove damaged or worn grass deflector.
2. Place spacer and spring onto grass deflector. Place the L end of spring behind deck edge.

Note: Make sure the L end of spring is installed behind deck edge before installing the bolt as shown in figure 66.

3. Install bolt and nut. Place J hook end of spring around grass deflector (Fig. 66).

Important The grass deflector must be able to lower down into position. Lift the deflector up to test that it lowers into the full down position.

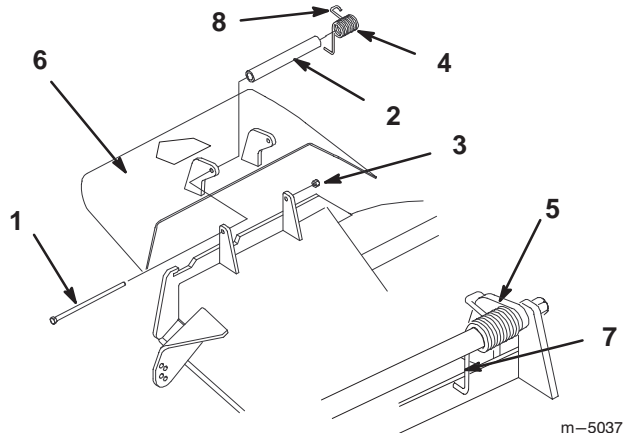
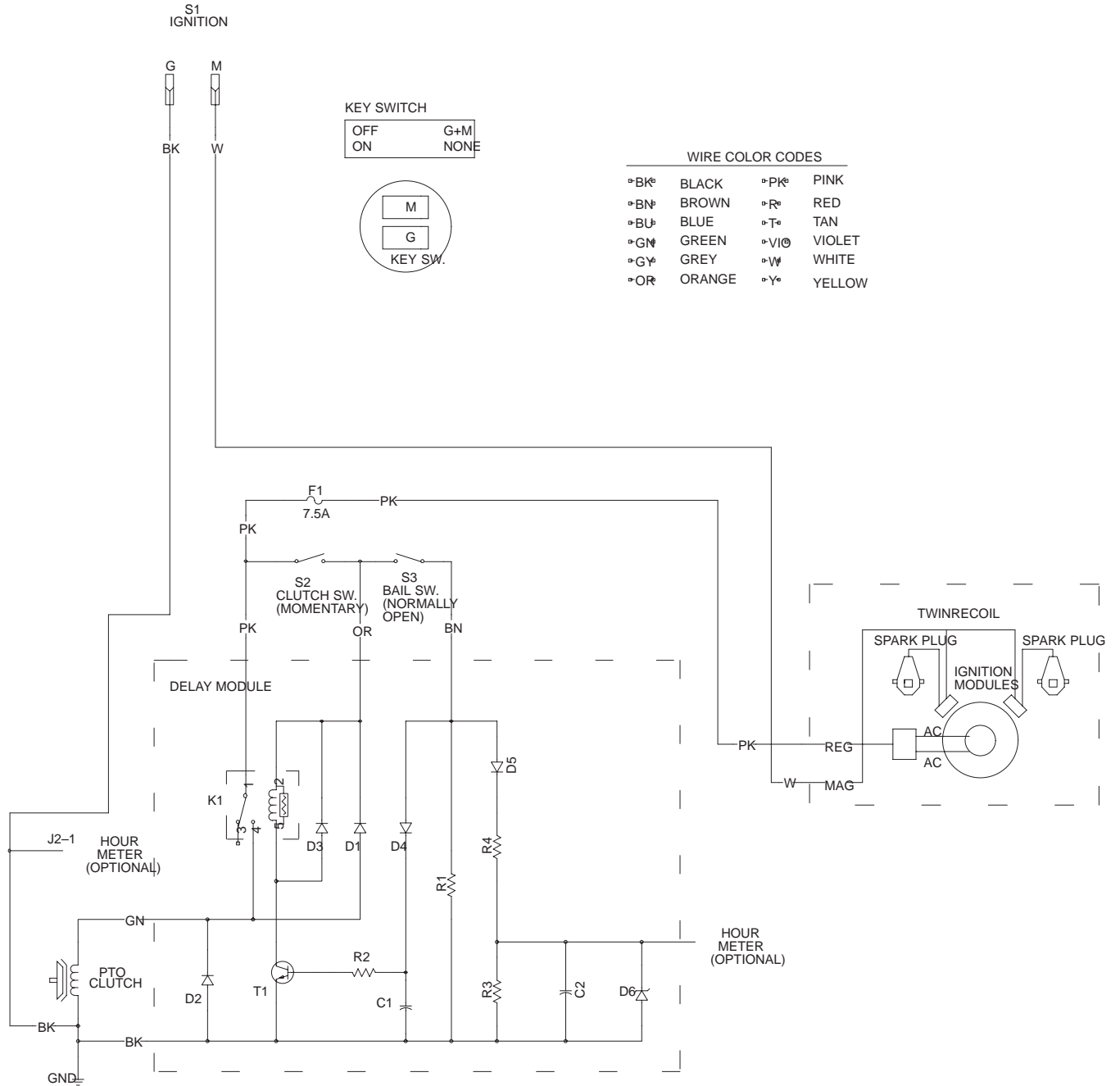

Figure 66

- | | |
|---------------------|---|
| 1. Bolt | 6. Grass Deflector |
| 2. Spacer | 7. L end of spring, place behind deck edge before installing bolt |
| 3. Locknut | 8. J hook end of spring |
| 4. Spring | |
| 5. Spring installed | |

Wiring Diagram



Cleaning and Storage

1. Disengage the power take off (PTO), set the parking brake, and turn the ignition key to off. Remove the key.
 2. Remove grass clippings, dirt, and grime from the external parts of the entire machine, especially the engine. Clean dirt and chaff from the outside of the engine's cylinder head fins and blower housing.
- Important** You can wash the machine with mild detergent and water. Do not pressure wash the machine. Avoid excessive use of water, especially near the control panel, and engine.
3. Check the brake; refer to Servicing the Brake, page 28.
 4. Service the air cleaner; refer to Servicing the Air Cleaner, page 24.
 5. Grease the machine; refer to Greasing and Lubrication, page 27.
 6. Change the crankcase oil; refer to Servicing the Engine Oil, page 25.
 7. Check the tire pressure; refer to Checking the Tire Pressure Service, page 28.
 8. For long-term storage (more than 90 days) add stabilizer/conditioner additive to fuel in the tank.

- A. Run engine to distribute conditioned fuel through the fuel system (5 minutes).
- B. Stop engine, allow to cool and drain the fuel tank; refer to Servicing the Fuel Tank, page 30, or operate engine until it stops.
- C. Restart engine and run until it stops. Repeat, on choke until engine will not restart.
- D. Dispose of fuel properly. Recycle as per local codes.

Note: Do not store stabilizer/conditioned gasoline over 90 days.

9. Remove the spark plug(s) and check its condition; refer to Servicing the Spark Plug, page 26. With the spark plug(s) removed from the engine, pour two tablespoons of engine oil into the spark plug hole. Now use the starter to crank the engine and distribute the oil inside the cylinder. Install the spark plug(s). Do not install the wire on the spark plug(s).
10. Check and tighten all bolts, nuts, and screws. Repair or replace any part that is damaged or defective.
11. Paint all scratched or bare metal surfaces. Paint is available from your Authorized Service Dealer.
12. Store the machine in a clean, dry garage or storage area. Remove the key from the ignition switch and keep it in a memorable place. Cover the machine to protect it and keep it clean.

Troubleshooting

PROBLEM	POSSIBLE CAUSES	CORRECTIVE ACTION
Engine will not start, starts hard, or fails to keep running.	<ol style="list-style-type: none"> 1. Fuel tank is empty. 2. Choke is not ON. 3. Air cleaner is dirty. 4. Spark plug wire is loose or disconnected. 5. Spark plug is pitted, fouled, or gap is incorrect. 6. Dirt in fuel filter. 7. Dirt, water, or stale fuel is in fuel system. 	<ol style="list-style-type: none"> 1. Fill fuel tank with gasoline. 2. Move throttle lever to choke position. 3. Clean or replace air cleaner element. 4. Install wire on spark plug. 5. Install new, correctly gapped spark plug. 6. Replace fuel filter. 7. Contact Authorized Service Dealer.

PROBLEM	POSSIBLE CAUSES	CORRECTIVE ACTION
Engine loses power.	<ol style="list-style-type: none"> 1. Engine load is excessive. 2. Air cleaner is dirty. 3. Oil level in crankcase is low. 4. Cooling fins and air passages under engine blower housing are plugged. 5. Spark plug is pitted, fouled, or gap is incorrect. 6. Vent hole in fuel cap is plugged. 7. Dirt in fuel filter. 8. Dirt, water, or stale fuel is in fuel system. 	<ol style="list-style-type: none"> 1. Reduce ground speed. 2. Clean air cleaner element. 3. Add oil to crankcase. 4. Remove obstruction from cooling fins and air passages. 5. Install new, correctly gapped spark plug. 6. Clean or replace the fuel cap. 7. Replace fuel filter. 8. Contact Authorized Service Dealer.
Engine overheats.	<ol style="list-style-type: none"> 1. Engine load is excessive. 2. Oil level in crankcase is low. 3. Cooling fins and air passages under engine blower housing are plugged. 	<ol style="list-style-type: none"> 1. Reduce ground speed. 2. Add oil to crankcase. 3. Remove obstruction from cooling fins and air passages.
Machine does not drive.	<ol style="list-style-type: none"> 1. Shift lever is in NEUTRAL. 2. Traction belt is worn, loose or broken. 3. Traction belt is off pulley. 	<ol style="list-style-type: none"> 1. Move shift lever to a drive gear position. 2. Change Belt. 3. Change Belt.
Abnormal vibration.	<ol style="list-style-type: none"> 1. Cutting blade(s) is/are bent or unbalanced. 2. Blade mounting bolt is loose. 3. Engine mounting bolts are loose. 4. Loose engine pulley, idler pulley, or blade pulley. 5. Engine pulley is damaged. 6. Blade spindle bent. 	<ol style="list-style-type: none"> 1. Install new cutting blade(s). 2. Tighten blade mounting bolt. 3. Tighten engine mounting bolts. 4. Tighten the appropriate pulley. 5. Contact Authorized Service Dealer. 6. Contact Authorized Service Dealer.

PROBLEM	POSSIBLE CAUSES	CORRECTIVE ACTION
Uneven cutting height.	<ol style="list-style-type: none"> 1. Blade(s) not sharp. 2. Cutting blade(s) is/are bent. 3. Mower is not level. 4. Underside of mower is dirty. 5. Tire pressure is incorrect. 6. Blade spindle bent. 	<ol style="list-style-type: none"> 1. Sharpen blade(s). 2. Install new cutting blade(s). 3. Level mower from side-to-side and front-to-rear. 4. Clean the underside of the mower. 5. Adjust tire pressure. 6. Contact Authorized Service Dealer.
Blades do not rotate.	<ol style="list-style-type: none"> 1. PTO Drive belt is worn, loose or broken. 2. PTO Drive belt is off pulley. 3. Deck belt is worn, loose or broken. 4. Deck belt is off pulley. 	<ol style="list-style-type: none"> 1. Install new drive belt. 2. Install drive belt and check adjusting shafts and belt guides for correct position. 3. Install new deck belt. 4. Install deck pulley and check the idler pulley, idler arm and spring for correct position and function.



LCE

The Toro Total Coverage Guarantee

A One-Year Limited Warranty

Conditions and Products Covered

The Toro Company and its affiliate, Toro Warranty Company, pursuant to an agreement between them, jointly promise to repair any Toro Product used for commercial, institutional, or rental purposes if defective in materials or workmanship. The following time periods apply from the date of purchase:

<u>Products</u>	<u>Warranty Period</u>
• All Products	1 year
• All Spindles	2 years parts and labor; third year, parts only
• Engines/Hydraulic Systems* on the following: Outfront and Mid-Mount Z's ProLine Mid-Size Mowers Groundsmaster® Riding Mowers Backpack Blowers	2 years
• Deck Shells (36"–72") on the following: ProLine Mid-Size Mowers Mid-Mount Z's	2 years
• Electric Clutch on 200 Series Mid-Mount Z's	2 years

This warranty includes the cost of parts and labor, but you must pay transportation costs.

This warranty applies to:

- Outfront and Mid-Mount Z's
- ProLine Mid-Size Mowers
- Groundsmaster Riding Mowers
- Turf Maintenance Equipment
- Debris Management Equipment

* Some engines used on Toro LCE Products are warranted by the engine manufacturer.

Instructions for Obtaining Warranty Service

If you think that your Toro Product contains a defect in materials or workmanship, follow this procedure:

1. Contact any Toro Authorized or Master Service Dealer to arrange service at their dealership. To locate a dealer convenient to you, access our website at www.Toro.com. U.S. Customers may also call 800-348-2424.
2. Bring the product and your proof of purchase (sales receipt) to the Service Dealer.

If for any reason you are dissatisfied with the Service Dealer's analysis or with the assistance provided, contact us at:

LCB Customer Service Department
Toro Warranty Company
8111 Lyndale Avenue South
Bloomington, MN 55420-1196
888-577-7466 (U.S. customers)
877-484-9255 (Canada customers)

Countries Other than the United States or Canada

Customers who have purchased Toro products exported from the United States or Canada should contact their Toro Distributor (Dealer) to obtain guarantee policies for your country, province, or state. If for any reason you are dissatisfied with your Distributor's service or have difficulty obtaining guarantee information, contact the Toro importer. If all other remedies fail, you may contact us at Toro Warranty Company.

Owner Responsibilities

You must maintain your Toro Product by following the maintenance procedures described in the operator's manual. Such routine maintenance, whether performed by a dealer or by you, is at your expense.

Items and Conditions Not Covered

There is no other express warranty except for special emission system coverage on some products. This express warranty does not cover the following:

- Cost of regular maintenance service or parts, such as filters, fuel, lubricants, tune-up parts, blade sharpening, brake and clutch adjustments.
- Any product or part which has been altered or misused or required replacement or repair due to normal wear, accidents, or lack of proper maintenance.
- Repairs necessary due to improper fuel, contaminants in the fuel system, or failure to properly prepare the fuel system prior to any period of non-use over three months.
- Pickup and delivery charges.

All repairs covered by this warranty must be performed by an Authorized Toro Service Dealer using Toro approved replacement parts.

General Conditions

Repair by an Authorized Toro Service Dealer is your sole remedy under this warranty.

Neither The Toro Company nor Toro Warranty Company is liable for indirect, incidental or consequential damages in connection with the use of the Toro Products covered by this warranty, including any cost or expense of providing substitute equipment or service during reasonable periods of malfunction or non-use pending completion of repairs under this warranty.

Some states do not allow exclusions of incidental or consequential damages, or limitations on how long an implied warranty lasts, so the above exclusions and limitations may not apply to you.

All implied warranties of merchantability (that the product is fit for ordinary use) and fitness for use (that the product is fit for a particular purpose) are limited to the duration of the express warranty.

This warranty gives you specific legal rights, and you may also have other rights which vary from state to state.