



MODEL NO. 30200—70001 & UP

**OPERATOR'S
MANUAL**

GROUNDMASTER® 1000L
Traction Unit



To assure maximum safety, optimum performance, and to gain knowledge of the product, it is essential that you or any other operator of the mower read and understand the contents of this manual before the engine is ever started. Pay particular attention to the SAFETY INSTRUCTIONS highlighted by this symbol:



The safety alert symbol means CAUTION, WARNING or DANGER—personal safety instruction. Failure to comply with the instruction may result in personal injury.

FOREWORD

The GROUNDSMASTER 1000L was developed to satisfy the demand for a maneuverable, intermediate size, turf maintenance rotary mower. The machine has advanced concepts in engineering, design and safety; and if maintained properly, it will give excellent service.

Since the GROUNDSMASTER 1000L is a high quality product, Toro is concerned about the future use of the machine and the safety of the user. Read this manual to familiarize yourself with the proper set up, operation, and maintenance instructions.

Certain information in this manual is emphasized. DANGER, WARNING and CAUTION identify personal safety related information. IMPORTANT identifies mechanical information demanding special attention. Be sure to read the directive because it deals with the possibility of damaging a part or parts of the machine. NOTE identifies general information worthy of special attention.

If help concerning set up, operation, maintenance or safety is ever needed, contact a local Authorized Toro Distributor. In addition to genuine Toro replacement parts, the distributor also has optional equipment from the complete line of Toro turf care equipment. Keep your Toro all Toro – buy genuine Toro replacement parts and accessories.

Whenever you have questions or need service, contact your local authorized Toro Distributor. In addition to having a complete line of accessories and professional turf care service technicians, the distributor has a complete line of genuine TORO replacement parts to keep your machine operating properly.

Keep your TORO all TORO. Buy genuine TORO parts and accessories.

TABLE OF CONTENTS

SAFETY INSTRUCTIONS	3
SPECIFICATIONS	9
BEFORE OPERATING	10
CONTROLS	14
OPERATING INSTRUCTIONS	16
MAINTENANCE	18
PREPARATION FOR SEASONAL STORAGE	28
PRODUCT IDENTIFICATION	29

Safety

Training

1. Read the instructions carefully. Be familiar with the controls and the proper use of the equipment.
2. Never allow children or people unfamiliar with these instructions to use the lawnmower. Local regulations may restrict the age of the operator.
3. Never mow while people, especially children, or pets are nearby.
4. Keep in mind that the operator or user is responsible for accidents or hazards occurring to other people or their property.
5. Do not carry passengers.
6. All drivers should seek and obtain professional and practical instruction. Such instruction should emphasize:
 - the need for care and concentration when working with rideon machines;
 - control of a ride on machine sliding on a slope will not be regained by the application of the brake. The main reasons for loss of control are:
 - insufficient wheel grip;
 - being driven too fast;
 - inadequate braking;
 - the type of machine is unsuitable for its task;
 - lack of awareness of the effects of ground conditions, especially slopes;

Preparation

1. While mowing, always wear substantial footwear and long trousers. Do not operate the equipment when barefoot or wearing open sandals.
2. Thoroughly inspect the area where the equipment is to be used and remove all objects which may be thrown by the machine.

3. **WARNING—Petrol is highly flammable.**

- Store fuel in containers specifically designed for this purpose.
 - Refuel outdoors only and do not smoke while refueling.
 - Add fuel before starting the engine. Never remove the cap of the fuel tank or add petrol while the engine is running or when the engine is hot.
 - If petrol is spilled, do not attempt to start the engine but move the machine away from the area of spillage and avoid creating any source of ignition until petrol vapors have dissipated.
 - Replace all fuel tanks and container caps securely.
4. Replace faulty silencers.
 5. Before using, always visually inspect to see that the blades, blade bolts and cutter assembly are not worn or damaged. Replace worn or damaged blades and bolts in sets to preserve balance.
 6. On multi-bladed machines, take care as rotating one blade can cause other blades to rotate.

Operation

1. Do not operate the engine in a confined space where dangerous carbon monoxide fumes can collect.
2. Mow only in daylight or in good artificial light.
3. Before attempting to start the engine, disengage all blade attachment clutches and shift into neutral.
4. Do not use on slopes of more than:
 - Never mow side hills over 5°
 - Never mow uphill over 10°
 - Never mow downhill over 15°
5. Remember there is no such thing as a “safe” slope. Travel on grass9 slopes requires particu-

lar care. To guard against overturning:

- do not stop or start suddenly when going up or downhill;
 - engage clutch slowly, always keep machine in gear, especially when travelling downhill;
 - machine speeds should be kept low on slopes and during tight turns;
 - stay alert for bumps and hollows and other hidden hazards;
 - never mow across the face of the slope, unless the lawnmower is designed for this purpose.
6. Use care when pulling loads or using heavy equipment.
 - Use only approved drawbar hitch points.
 - Limit loads to those you can safely control.
 - Do not turn sharply. Use care when reversing.
 - Use counterweight(s) or wheel weights when suggested in the instruction handbook .
 7. Watch out for traffic when crossing or near roadways.
 8. Stop the blades rotating before crossing surfaces other than grass.
 9. When using any attachments, never direct discharge of material toward bystanders nor allow anyone near the machine while in operation .
 10. Never operate the lawnmower with defective guards, shields or without safety protective devices in place.
 11. Do not change the engine governor settings or overspeed the engine. Operating the engine at excessive speeds may increase the hazard of personal injury.
 12. Before leaving the operator's position:
 - disengage the power take-off and lower the attachments;
 - change into neutral and set the parking brake;
 13. Disengage drive to attachments, stop the engine, and disconnect the spark plug wire(s) or remove the ignition key
 - stop the engine and remove the key.
 - before cleaning blockages or unclogging chute;
 - before checking, cleaning or working on the lawnmower;
 - after striking a foreign object. Inspect the lawnmower for damage and make repairs before restarting and operating the equipment;
 - if the machine starts to vibrate abnormally (check immediately).
 14. Disengage drive to attachments when transporting or not in use.
 15. Stop the engine and disengage drive to attachment
 - before refueling;
 - before removing the grass catcher;
 - before making height adjustment unless adjustment can be made from the operator's position.
 16. Reduce the throttle setting during engine runout and, if the engine is provided with a shutoff valve, turn the fuel off at the conclusion of mowing.

Maintenance and Storage

1. Keep all nuts, bolts and screws tight to be sure the equipment is in safe working condition.
2. Never store the equipment with petrol in the tank inside a building where fumes may reach an open flame or spark.
3. Allow the engine to cool before storing in any enclosure.
4. To reduce the fire hazard, keep the engine, silencer, battery compartment and petrol storage area free of grass, leaves, or excessive grease.
5. Check the grass catcher frequently for wear or

deterioration.

6. Replace worn or damaged parts for safety.
7. If the fuel tank has to be drained, this should be done outdoors
8. On multi-bladed machines, take care as rotating one blade can cause other blades to rotate.
9. When machine is to be parked, stored or left unattended, lower the cutting means unless a positive mechanical lock is used.

Sound & Vibration Levels

Sound Levels

This unit has an equivalent continuous A-weighted sound pressure at the operator ear of: 89 dB(A), based on measurements of identical machines per 91/386/EEC.







This unit has a sound power level of 104 LWA, based on measurements of identical machines per procedures outlined in Directive 84/538/EEC and amendments





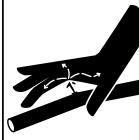

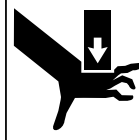
Vibration Levels





This unit has a vibration level of 8.7 m/s² at the hands/arms, based on measurements of identical machines per ISO 5349 procedures.

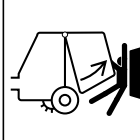
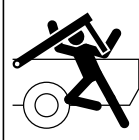

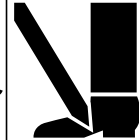

This unit has a vibration level of 0.1 m/s² at the posterior based on measurements of identical machines per ISO 2631 procedures.

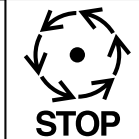
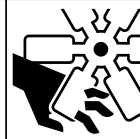
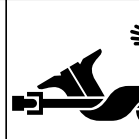



Symbol Glossary

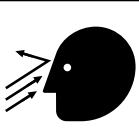
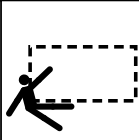
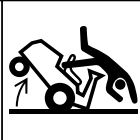

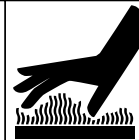

							
Caustic liquids, chemical burns to fingers or hand	Poisonous fumes or toxic gases, asphyxiation	Electrical shock, electrocution	High pressure fluid, injection into body	High pressure spray, erosion of flesh	High pressure spray, erosion of flesh	Crushing of fingers or hand, force applied from above	Crushing of toes or foot, force applied from above

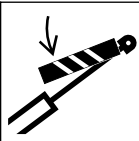
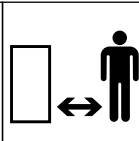
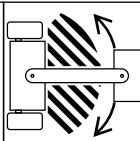
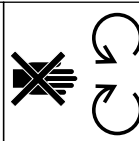

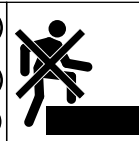

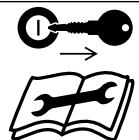

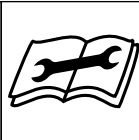
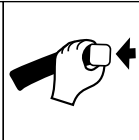
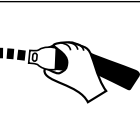
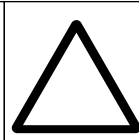



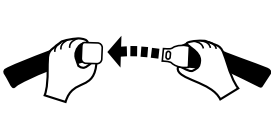









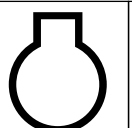
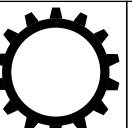
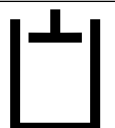



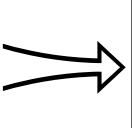
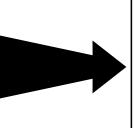
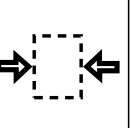
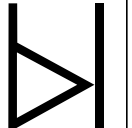
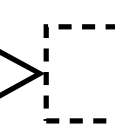
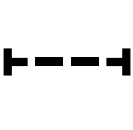

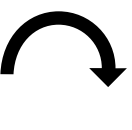
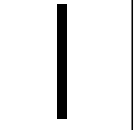
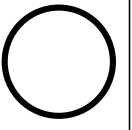
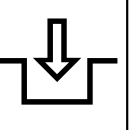
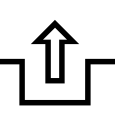
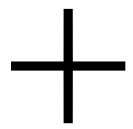

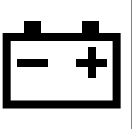
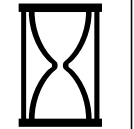

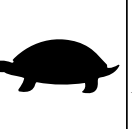
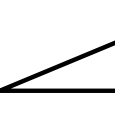
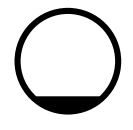
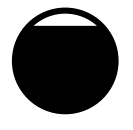
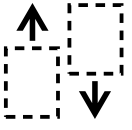
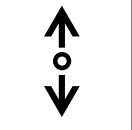
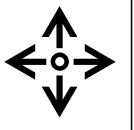
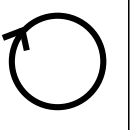
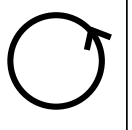

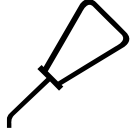
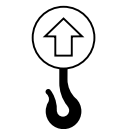
							
Crushing of whole body, applied from above	Crushing of torso, force applied from side	Crushing of fingers or hand, force applied from side	Crushing of leg, force applied from side	Crushing of whole body	Crushing of head, torso and arms	Cutting of fingers or hand	Cutting of foot

						
Cutting or entanglement of foot, rotating auger	Severing of foot, rotating knives	Severing of fingers or hand, impeller blade	Wait until all machine components have completely stopped before touching them	Severing of fingers or hand, engine fan	Whole body entanglement, implement input drive line	Fingers or hand entanglement, chain drive

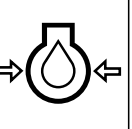
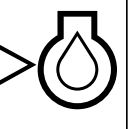
							
Hand & arm entanglement, belt drive	Thrown or flying objects, whole body exposure	Thrown or flying objects, face exposure	Runover/backover, (relevant machine to appear in dashed box)	Machine tipping, riding mower	Machine rollover, ROPS (relevant machine to appear in dashed box)	Stored energy hazard, kickback or upward motion	Hot surfaces, burns to fingers or hands

							
Explosion	Fire or open flame	Secure lifting cylinder with locking device before getting in hazardous area	Stay a safe distance from the machine	Stay clear of articulation area while engine is running	Do not open or remove safety shields while engine is running	Do not step on loading platform if PTO is connected to tractor & engine is running	Do not step

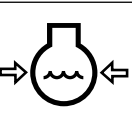
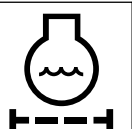
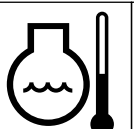
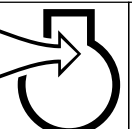
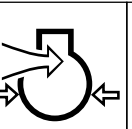
						
Shut off engine & remove key before performing maintenance or repair work	Riding on this machine is allowed only on a passenger seat & only if the driver's view is not hindered	Consult technical manual for proper service procedures	Fasten seat belts	Safety alert triangle	outline safety alert symbol	Read operator's manual

							
Consult technical manual for proper service procedures	Fasten seat belts	Safety alert triangle	Outline safety alert symbol	Read operator's manual	Fire, open light and smoking prohibited	Eye protection must be worn	
							
Head protection must be worn	Hearing protection must be worn	Caution, toxic risk	First aid	Flush with water	Engine	Transmission	Hydraulic system
							
Brake system	Oil	Coolant (water)	Intake air	Exhaust gas	Pressure	Level indicator	Liquid level
							
Filter	Temperature	Failure/Malfunction	Start switch/mechanism	On/start	Off/stop	Engage	Disengage
							
Plus/increase/positive polarity	Minus/decrease/negative polarity	Horn	Battery charging condition	Hourmeter/elapsed operating hours	Fast	Slow	Continuous variable, linear
							
Volume empty	Volume full	Machine travel direction, forward/rearward	Control lever operating direction, dual direction	Control lever operating direction, multiple direction	Clockwise rotation	Counter-clockwise rotation	Grease lubrication point
							
Oil lubrication point	Lift point	Jack or support point	Draining/emptying	Engine lubricating oil	Engine lubricating oil pressure	Engine lubricating oil level	Engine lubricating oil filter
							
Engine lubricating oil temperature	Engine coolant	Engine coolant pressure	Engine coolant filter	Engine coolant temperature	Engine intake/combustion air	Engine intake/combustion air pressure	Engine intake/air pressure filter

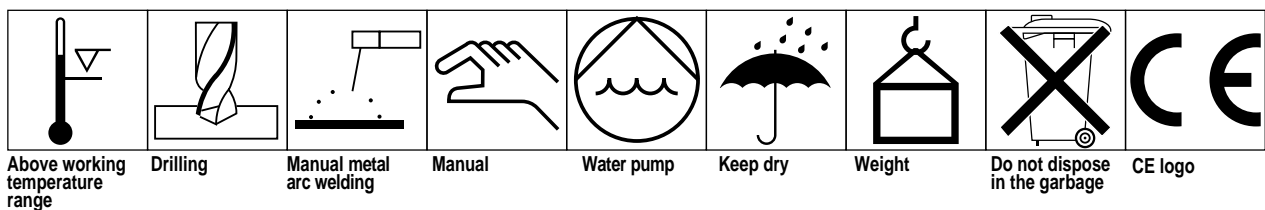
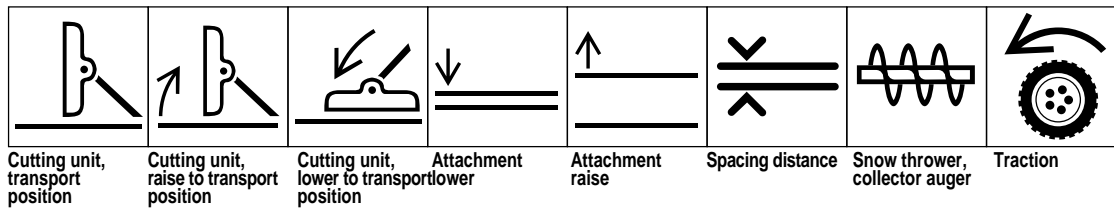
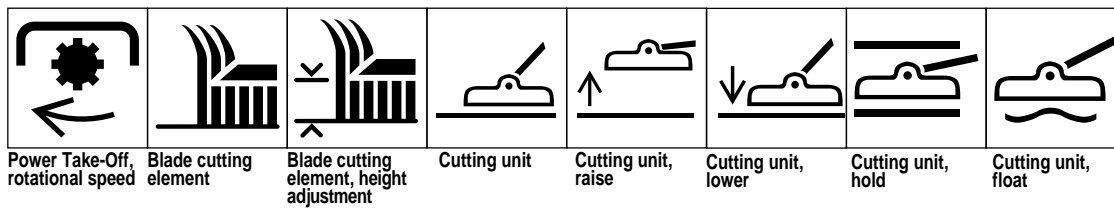
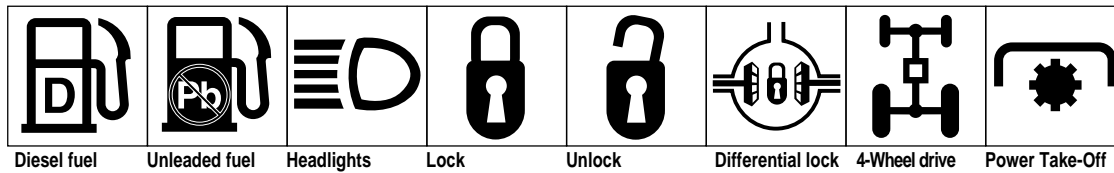
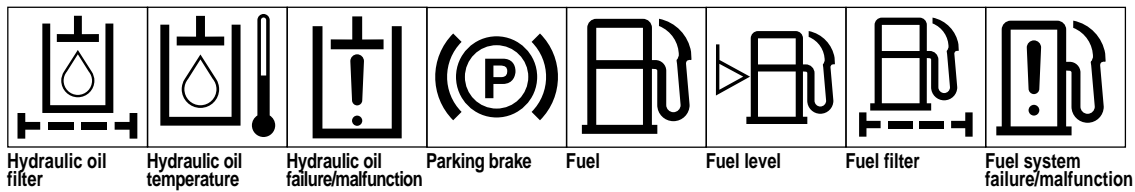
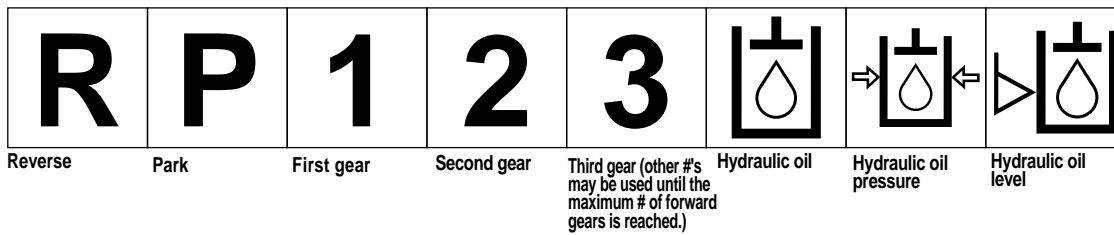
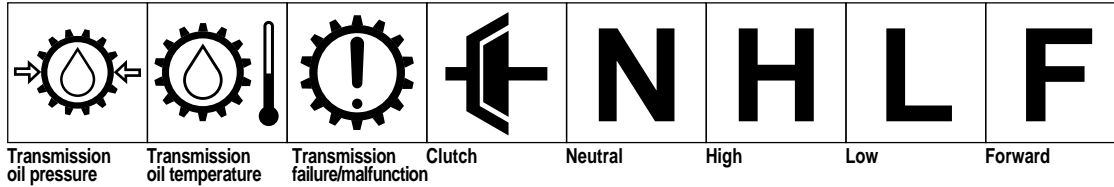
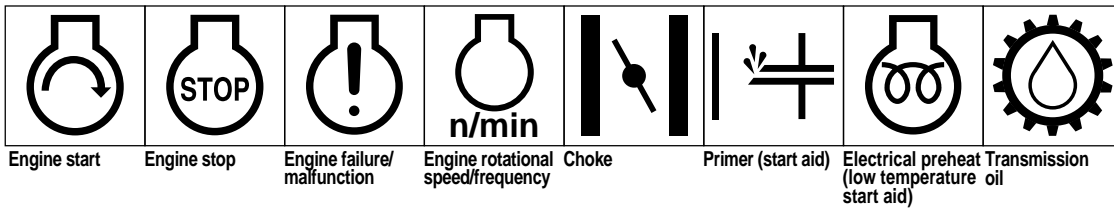

Specifications

Engine:

Manufacturer—Kawasaki
Horsepower—20 (16 Kw) @ 3600 RPM
Displacement—617 cc
Crankcase Capacity—1.6 qt. (1.5 L).
Governor—Mechanical.
Governor Limit—3350–3550 RPM.
Idle Speed—1500 RPM.

Air Cleaner: Donaldson heavy duty with precleaner. Remote mounted.

Fuel Tank Capacity: 8.5 gal. (32 l).

Fuel Filter: Replaceable inline type.

Fuel Pump: 12-volt electric (transistor type).

Cooling System:

Radiator—4 qt (3.8 l) capacity.
Expansion Tank—Remote mounted; 1/2 qt (.4 l) capacity. System contains a 50/50 mix of ethylene glycol anti-freeze and water.

Electrical: Battery—12-volt, BCI group size 26, 530 Amp at –18°C. 20-amp alternator with regulator/rectifier.

Drive Coupling: Transmission driven by steel shaft with flexible rubber couplings at each end.

Transmission:

Manufacturer & Type—Sundstrand hydrostatic, Type U15. Normal Charge Pressure – 70–150 psi (483–1034 kPa).
Implement Relief Setting – 700–800 psi (4826 –5516 kPa).

Hydraulic Filter: 25-micron mounted directly to transmission. Replaceable (Toro Part No. 23-2300).

Drive Axle: Manufacturer – Dana Corp., Model GT–20. Axle serves as a hydraulic fluid reservoir and mates directly with the transmission. Approximately 5 qt (4.7 l) capacity. 4-Wheel Drive has mechanical rear axle coupled to front axle by a drive shaft and clutch.

Brakes: Mechanical drum type, 7 in. (17.8 cm) dia. x 1-3/4 in. (45 mm) wide. Individually controlled by two pedals connected by cable and conduit for steering assist. Pedals may be latched together for two

wheel braking. Lever provided for the parking brake.

Tires, Wheels, Pressure:

Front Tires—23 x 8.50 - 12
Rear Tires—16 x 6.50 - 8
All tires 4 ply rating, tubeless type.
Pressure—20 psi (138 kPa).

Steering: 13 in. (33 cm) steering wheel. TRW power steering valve.

Main Frame: Frame is welded, formed steel.

Seat: Adjustable contoured fit with suspension lever.

Instrumentation: Fuel gauge, water temperature gauge, hour meter and warning lights for high temperature shutdown, oil pressure, amperage are mounted on the console.

Controls: Throttle, PTO switch, parking brake, implement lift, ignition switch are all hand-operated. Forward/reverse traction pedal and turning brakes are foot operated.

PTO Drive: PTO shaft is clutched by a torque-teamed HA Section, spring tensioned V-belt directly from the engine output shaft. PTO shaft engaged by electric clutch/brake assembly. PTO speed – 2200 RPM @ 3450 RPM engine speed.

Implement Connection—Universal joint and telescoping shaft assembly.

Lift Cylinders: Two, with 2 in. (51 mm) bore, 3.5 in. (89 mm) stroke.

Interlock Switches: Prevents engine starting if traction pedal or PTO switch are engaged. Stops the engine if operator leaves seat with either traction pedal or PTO switch engaged.

Dimensions and Weight:

Length:	208 cm (82 in.)
Width (Rear Wheels):	111 cm (44 in.)
Height:	127 cm (50 in.)
Weight:	416 kg (1116 lb)

Before Operating

CHECK THE ENGINE OIL

The engine is shipped with 3.8 qt (3.6 l) of oil in the crankcase; however, check the oil level before and after you first start the engine.

1. Position the machine on a level surface.
2. Open the hood.
3. Remove the dipstick and wipe it with a clean rag. Insert the dipstick into the tube and make sure it is seated fully. Remove the dipstick and check the level of oil (Fig. 1). If the oil level is low, add enough oil to raise the level to the FULL mark on the dipstick. Do not overfill (Fig. 2).

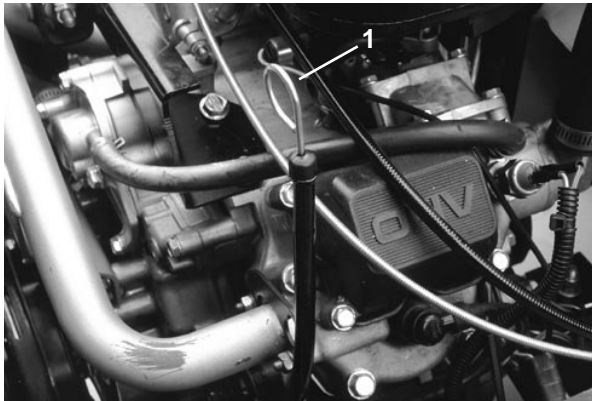

Figure 1

1. Engine oil dipstick

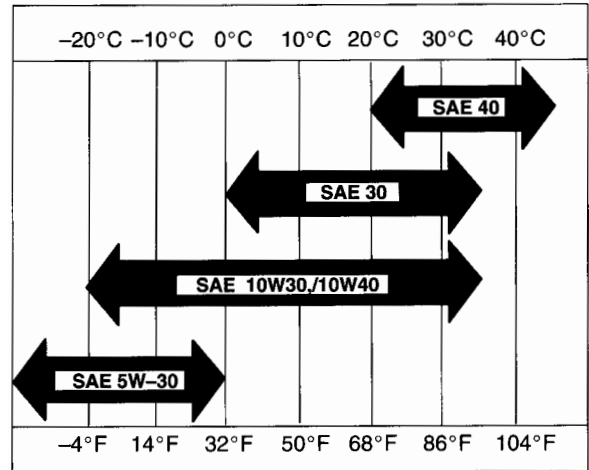

Figure 2

1. Engine oil fill

dipstick, add 1 pint (0.47 l) of oil and recheck the level. Do not overfill.

4. The engine uses any high-quality 10W30 detergent oil having the American Petroleum Institute – API – “service classification” SE or SF. Use the following chart to select the proper viscosity grade for the temperature expected.



Note: Using multigrade oils (5W20, 10W30 and 10W40) will increase oil consumption. Check the oil level more often when using them.

IMPORTANT: Check the oil level every 5 operating hours or daily. Change oil after the first 8 hours of operation. Thereafter, change the engine oil every after every 50 hours of operation and the engine oil filter after every 100 hours of operation.

5. Insert the dipstick into the tube and install the fill cap.

CHECK THE COOLING SYSTEM

Clean debris off the screen, oil cooler and front of the radiator daily (Fig. 3); hourly if conditions are extremely dusty and dirty. Refer to *Cleaning the Radiator and Screen* section.

Note: If the level of oil is at the ADD mark on the

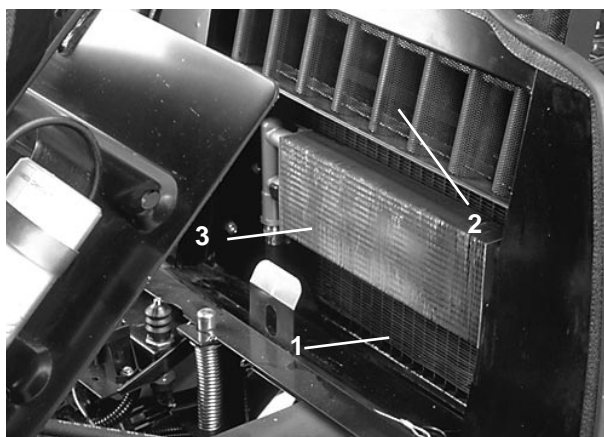

Figure 3

1. Radiator
2. Radiator screen
3. Oil cooler

The cooling system is filled with a 50/50 solution of water and permanent ethylene glycol anti-freeze. Check the level of coolant at the beginning of each day (Fig. 4) before starting the engine. Capacity of the cooling system is 4 quarts (1).



CAUTION

If the engine has been running, pressurized hot coolant can escape and cause burns when the radiator cap is removed.

1. Carefully remove the radiator cap and the expansion tank cap.

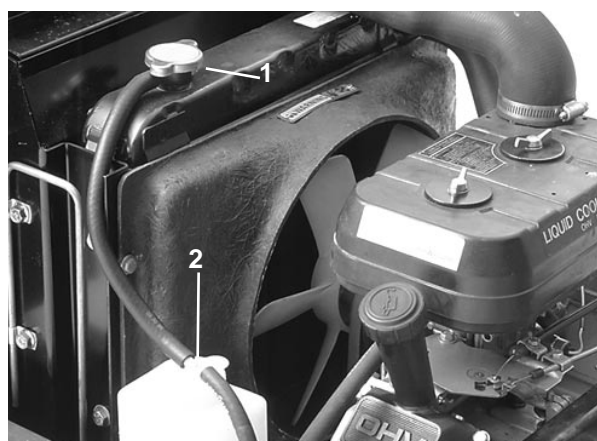

Figure 4

1. Radiator cap
2. Expansion tank cap

2. Check the level of coolant in the radiator. The

radiator should be filled to the top of the filler neck and the expansion tank filled to between the marks on its side.

3. If the coolant level is low, replenish the system. **DO NOT OVERFILL.**
4. Install the radiator and expansion tank caps.

CHECK HYDRAULIC SYSTEM FLUID

The hydraulic system was designed to operate on any high quality detergent oil having the American Petroleum Institute-API—"service classification" SF, CC or CD. Oil viscosity—weight—must be selected according to anticipated ambient temperature. Temperature/viscosity recommendations are:

Expected Ambient Temperature	Recommended Viscosity and type
Over 32° C	SAE 30, Type SF, CC or CD
4–38° C	SAE 10W-30 or 10W40 Type SF, CC or CD
–1–10° C	SAE 5W30, Type SF, CC or CD
Below –1° C	Type "F" or "FA" Automatic Transmission Fluid

Note: Do not mix engine oil and automatic transmission fluid or hydraulic component damage may result. When changing fluids, also change transmission filter. **DO NOT USE DEXRON II ATF.**

The axle housing acts as the reservoir for the system. The transmission and axle housing are shipped from the factory with approximately 5 quarts (4.7 l) of SAE 10W–30 engine oil. However, check the level of transmission oil before the engine is first started and daily thereafter.

1. Position the machine on a level surface. Place all controls in their neutral position and start the engine. Run the engine at lowest possible RPM to purge the system of air. **DO NOT ENGAGE THE PTO.** Turn the steering wheel several

times fully to the left and right. Raise the cutting unit to extend the lift cylinders, aiming steering wheels straight forward and stop the engine.

2. Remove the dipstick cap (Fig. 5) from filler neck and wipe it with a clean cloth. Screw the dipstick cap finger-tight onto filler neck; then remove it and check the level of fluid. If the level is not within 1/2 inch (13 mm) from the groove in the dipstick (Fig. 5), add SAE 10W-30 engine oil, or, if used, automatic transmission fluid to raise the level to groove mark. Do not overfill.

IMPORTANT: When adding transmission fluid to the hydraulic system, use a funnel with a fine wire screen—200 mesh or finer—and make sure funnel and transmission fluid are immaculately clean. This procedure prevents accidental contamination of the hydraulic system.

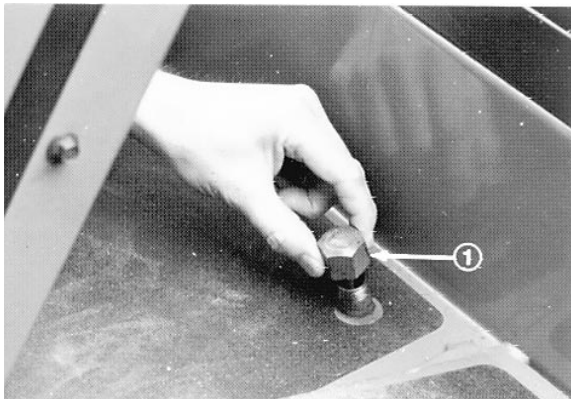

Figure 5

1. Hydraulic system reservoir fluid/add dipstick cap

3. Thread the dipstick fill cap finger-tight onto filler neck. It is not necessary to tighten cap with a wrench.
4. Check all hoses and fittings for leaks.

FILL THE FUEL TANK

THE TORO COMPANY STRONGLY RECOMMENDS THE USE OF FRESH, CLEAN, UNLEADED REGULAR GRADE GASOLINE IN TORO GASOLINE POWERED PRODUCTS. UNLEADED GASOLINE BURNS CLEANER, EXTENDS ENGINE LIFE, AND PROMOTES

GOOD STARTING BY REDUCING THE BUILD-UP OF COMBUSTION CHAMBER DEPOSITS. LEADED GASOLINE CAN BE USED IF UNLEADED IS NOT AVAILABLE. MINIMUM OCTANE RATING OF 87.

NOTE: NEVER USE METHANOL, GASOLINE CONTAINING METHANOL, GASOLINE CONTAINING MORE THAN 10% ETHANOL, GASOLINE ADDITIVES, OR WHITE GAS BECAUSE ENGINE FUEL SYSTEM DAMAGE COULD RESULT.



DANGER

Because fuel is flammable, caution must be used when storing or handling it. Do not fill the fuel tank while the engine is running, hot or when the machine is in an enclosed area. Vapors may build up and be ignited by a spark or flame source many feet away. **DO NOT SMOKE** while filling the fuel tank to prevent the possibility of an explosion. Always fill the fuel tank outside and wipe up any spilled fuel before starting the engine. Use a funnel or spout to prevent spilling, and fill the tank no higher than 2.5 cm (one inch) below top of the tank, (bottom of the filler neck). **DO NOT OVER FILL.**

Store fuel in a clean safety approved container and keep the cap on the container. Keep fuel in a cool, well-ventilated place; never in an enclosed area such as a hot storage shed. To assure volatility, do not buy more than a 30-day supply of gasoline, or a 6-month supply of diesel fuel.

Since many children like the smell of gasoline, keep it out of their reach because the fumes are explosive and dangerous to inhale.

1. Clean the area around the fuel tank cap.



Figure 6

1. Fuel tank cap

2. Remove the fuel tank cap.
3. Fill the tank to about one inch below top of the tank, (bottom of the filler neck). **DO NOT OVERFILL.** Then install the cap.

Controls

Service Brakes (Fig. 7)—The left and right brake pedals are connected to the left and right front wheels. Since both brakes work independently of each other, the brakes can be used to turn sharply or to increase traction if one wheel tends to slip while operating on certain slope conditions. However, wet grass or soft turf could be damaged when the brakes are used to turn sharply. To make a “quick-stop”, depress both brake pedals together. Always lock the brakes together when transporting the traction unit.

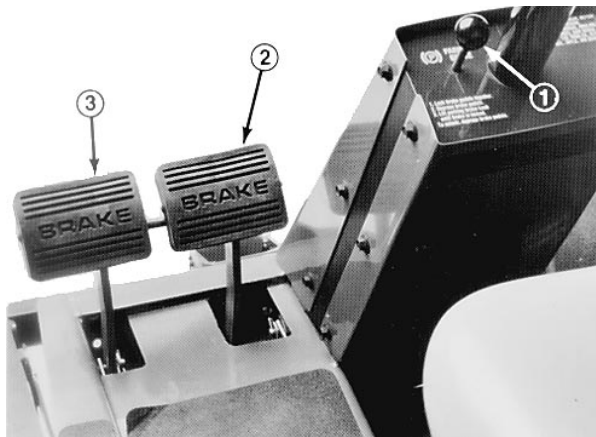

Figure 7

1. Parking brake knob
2. Right brake pedal
3. Left brake pedal

Parking Brake—Whenever the engine is shut off, the parking brake must be engaged to prevent accidental movement. To engage the parking brake, push lock arm (Fig. 8) on left brake pedal so that it locks together with the right pedal. Next, push down fully on both pedals and pull the parking brake knob out (Fig. 8) then release the pedals. To release the parking brake, depress both pedals until the parking brake knob retracts. Before starting the engine, however, the lock arm may be disengaged from the left brake pedal so both pedals work independently with each front wheel.

Amp Light (Fig. 9)—The amp light should be off when the engine is running. If it is on, the charging system should be checked and repaired if necessary.

Hour Meter (Fig. 9)—Accumulated engine operating time registers on the hour meter.

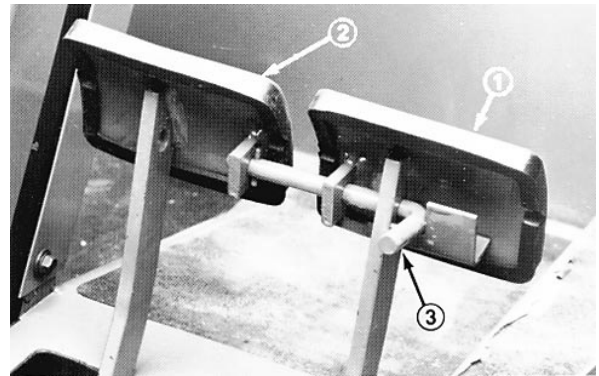

Figure 8

1. Left brake pedal
2. Right brake pedal
3. Lock arm

Temperature Gauge and High Temperature Light

(Fig. 9)—The coolant temperature gauge registers the coolant temperature in the system. If the temperature gets too high, the engine will automatically shut off and the High Temperature shutoff light will light. When this happens, turn the ignition key off, check the radiator for debris, check the fan belt and check the expansion tank for proper coolant level. The high temperature shutoff will automatically reset when the coolant temperature has reached a safe level.



Figure 9

1. Amp light
2. Hour meter
3. Coolant temperature gauge
4. High-temperature shut-off light
5. Ignition key switch
6. Oil pressure light
7. PTO switch
8. Fuel gauge
9. Choke
10. Throttle
11. Hydraulic lift lever

Low Oil Pressure Light (Fig. 9)—If engine oil pressure falls below a safe level, the light glows.

Stop the engine and repair before resuming operation.

PTO Switch (Fig. 9)—Pull up on the sleeve on the toggle switch handle and move the handle to ON to ENGAGE electric PTO clutch. Pull up on the sleeve and move the handle to OFF to DISENGAGE electric PTO clutch. The only time the PTO switch should be in the ENGAGE position is when the implement is down in operating position and ready to begin operation.

Ignition Key Switch (Fig. 9)—The ignition switch, which is used to start and stop the engine, has three positions: OFF, RUN and START. Turn the key clockwise—START position—to engage the starter motor. Release the key when the engine starts. The key will move automatically to the ON position. To shut the engine off, turn the key counterclockwise to the OFF position.

Choke (Fig. 9)—To start the engine, close the carburetor choke by pulling the choke control upward. After the engine starts, regulate the choke to keep the engine running smoothly. As soon as possible, open the choke by pushing it inward. A warm engine requires little or no choking.

Throttle (Fig. 9)—The throttle is used to operate the engine at various speeds. Moving the throttle forward increases engine speed—FAST; rearward decreases engine speed—SLOW. The throttle controls the speed of the cutter blades and, together with traction pedal, controls the ground speed of the traction unit.

Hydraulic Lift Lever (Fig. 9)—The hydraulic lift lever has three positions: FLOAT, TRANSPORT and RAISE. To lower the cutting unit to the ground, move the lift lever forward into the notch FLOAT. The FLOAT position is used for mowing and when the machine is not in operation. To raise the cutting unit, pull the lift lever rearward to the RAISE position. After the cutting unit is raised, allow the lift lever to move to the TRANSPORT position. The cutting unit must be raised when driving from one work area to another.



CAUTION

Never raise the cutting unit while blades are rotating because it is hazardous.

Traction Pedal (Fig. 10)—The traction pedal has two functions: one is to make the machine move forward, the other is to make it move rearward. Using the heel and toe of the right foot, depress the top of the pedal to move forward and the bottom of the pedal to move rearward. Ground speed is proportionate to how far pedal is depressed. For maximum ground speed, the traction pedal must be fully depressed while the throttle is in the FAST position. Maximum speed forward is 10 mph (16 Km/hour). To get maximum power under heavy load or when ascending a hill, have the throttle in the FAST position while depressing the traction pedal slightly to keep engine rpm high. When engine rpm begins to decrease, release the traction pedal slightly to allow rpm to increase.

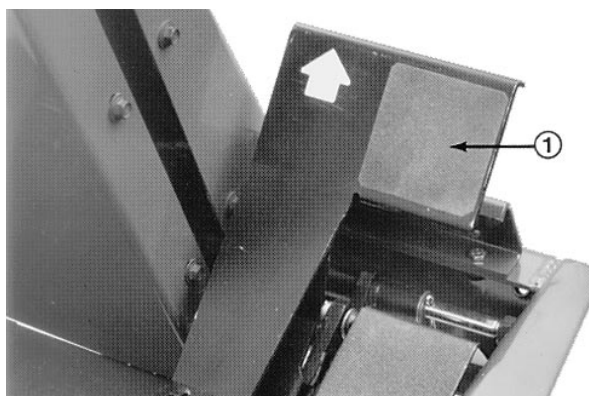



Figure 10

1. Traction pedal

Seat Adjusting Handle—To adjust the seat, loosen the adjusting knobs and slide the seat to the desired position. Tighten the knobs to lock the seat in place.

Operation

STARTING/STOPPING THE ENGINE

1. Ensure the parking brake is set, the PTO switch is in OFF and the lift lever is in the TRANSPORT or FLOAT position (Fig. 9). Remove your foot from the traction pedal and make sure it is in neutral.
 2. Pull the choke (Fig. 9) to the full choke position and move the throttle control (Fig. 9) to the slow position.
 3. Turn the key in the ignition switch to START (Fig. 9). Release the key immediately when the engine starts and allow it to return to the RUN position. Regulate the choke to keep the engine running smoothly.
 4. When the engine is started for the first time, or after an engine oil change or engine, transmission or axle overhaul, operate the machine in forward and reverse for one to two minutes. Also operate the lift lever and the PTO lever to assure correct operation of all parts. Turn the steering wheel to the left and right to check power steering response. Then shut the engine off and check fluid levels, check for oil leaks, loose parts and any other malfunctions.
-  **CAUTION**
Shut the engine off and wait for all moving parts to stop before checking for oil leaks, loose parts or other malfunctions.
5. To stop the engine, move the throttle control backward to SLOW, move the PTO switch to OFF and turn the ignition key to OFF. Remove the key from the switch to prevent accidental starting.

CHECKING THE INTERLOCK SAFETY SYSTEM

The purpose of the safety interlock system is to prevent the engine from cranking or starting unless the traction pedal is in neutral and the PTO switch is in the OFF position. Also, the engine will stop when

the PTO control is engaged or the traction pedal is depressed with the operator off the seat.

CAUTION

Do not disconnect the safety switches because they are for the operator's protection. Check operation of the switches daily to be sure the interlock system is operating correctly. If a switch is malfunctioning, replace it before operating the machine. Replace the switches every two years to be sure of maximum safety.

1. Move the PTO switch to OFF and remove your foot from the traction pedal so it is fully released.
2. Turn the key to START. The engine should crank. If the engine cranks, go to step 3. If the engine does not crank, there may be a malfunction in the interlock system.
3. Rise from the seat and engage the PTO switch while the engine is running. The engine should stop within 2 seconds. If the engine stops, the switch is operating correctly; thus, go to step 4. If the engine does not stop, there is a malfunction in the interlock system.
4. Rise from the seat and depress the traction pedal while the engine is running and the PTO lever is disengaged. The engine should stop within 2 seconds. If the engine stops, the switch is operating correctly; thus, continue operation. If the engine does not stop, there is a malfunction in the interlock system.

OPERATING CHARACTERISTICS

Practice driving the GROUNDMASTER® 1000L before initial operation because it has a hydrostatic transmission and its characteristics are different than some turf maintenance machines. Some points to consider when operating the traction unit and cutting unit are the transmission, engine speed, load on the cutting blades, and the importance of the brakes.

To maintain enough power for the traction unit and

cutting unit while mowing, regulate traction pedal to keep engine rpm high and somewhat constant. A good rule to follow is: decrease ground speed as the load on the cutting blades increases; and increase ground speed as the load on the blades decreases. This allows the engine, working with the transmission, to sense the proper ground speed while maintaining the high blade tip speed necessary for good quality of cut. Therefore, let the traction pedal to move upward as engine speed decreases, and depress the pedal slowly as speed increases. By comparison, when driving from one work area to another—with no load and cutting unit raised—have the throttle in the FAST position and depress the traction pedal slowly but fully to attain maximum ground speed.

CAUTION

Adequate rear weight is necessary to prevent the rear wheels from leaving the ground. Do not stop suddenly while cutting unit or implement is raised. Do not travel down hill with the cutting unit or implement raised. If the rear wheels leave the ground, steering is lost.

CAUTION: This product may exceed noise levels of 85 dB(A) at the operator position. Ear protectors are recommended for prolonged exposure to reduce the potential of permanent hearing damage.

Another characteristic to consider is the operation of the brakes. The brakes can be used to assist in turning the machine; however, use them carefully, especially on soft or wet grass because the turf may be torn accidentally. The brakes can be used to great advantage to control the direction of the cutting unit when trimming along fences or similar objects. Another benefit of the brakes is to maintain traction. For example; in some slope conditions, the uphill wheel slips and loses traction. If this situation occurs, depress the uphill brake pedal gradually and intermittently until the uphill wheel stops slipping, thereby increasing traction on the downhill wheel. If independent braking is not desired, engage the lever on the left brake pedal with right pedal. This provides simultaneous braking at both wheels.

Before stopping the engine, disengage all controls and move the throttle to SLOW. Moving the throttle to SLOW reduces high engine speed, noise and vibration. Turn the ignition key to OFF to stop the engine.

PUSHING OR TOWING THE TRACTION UNIT

In an emergency, the traction unit can be pushed or towed for a very short distance. However, Toro does not recommend this as standard procedure.

IMPORTANT: Do not push or tow the traction unit faster than 2 to 3 mph (3.2 to 4.8 Km/hour) because transmission may be damaged. If the traction unit must be moved a considerable distance, transport it on a truck or trailer. Whenever the traction unit is pushed or towed, the by-pass valve must be open.

1. Remove the hair pin and pivot the seat platform forward and locate seat support rod in the detent notch.
2. Depress and hold the pins located in the center of the two (2) check valve assemblies in the top of the transmission (Fig. 11) while pushing or towing the machine.

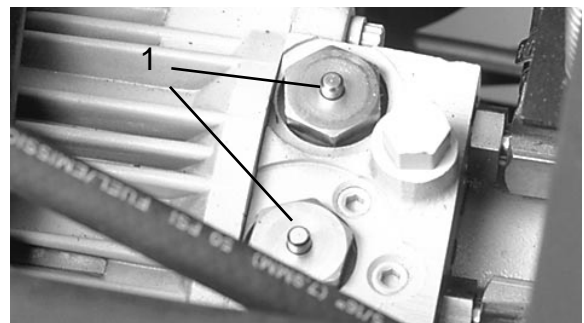

Figure 11

1. Transmission check valve bypass pins (2)

3. Start the engine momentarily after repairs are completed and make sure the pins are in the fully disengaged (fully up) position.

IMPORTANT: Running the machine with by-pass valve open will cause the transmission to overheat.

Maintenance

LUBRICATION

GREASING BEARINGS AND BUSHINGS

The traction unit has grease fittings that must be lubricated regularly with No. 2 General Purpose Lithium Base Grease. If the machine is operated under normal conditions, lubricate all bearings and bushings after every 50 hours of operation or immediately after every washing. Bearings and bushings must be lubricated daily when operating conditions are extremely dusty and dirty. Dusty and dirty operating conditions could cause dirt to get into the bearings and bushings, resulting in accelerated wear.

Apply a liberal coating of grease to the check valve pins once each year (Fig. 14). The traction unit has bearings and bushings that must be lubricated, and these lubrication points are shown in the following figures.

1. Wipe grease fitting clean so foreign matter cannot be forced into the bearing or bushing.
2. Pump grease into the bearing or bushing.
3. Wipe up excess grease.

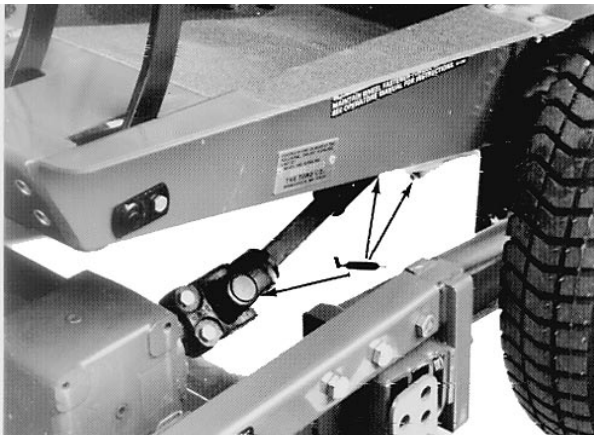

Figure 12

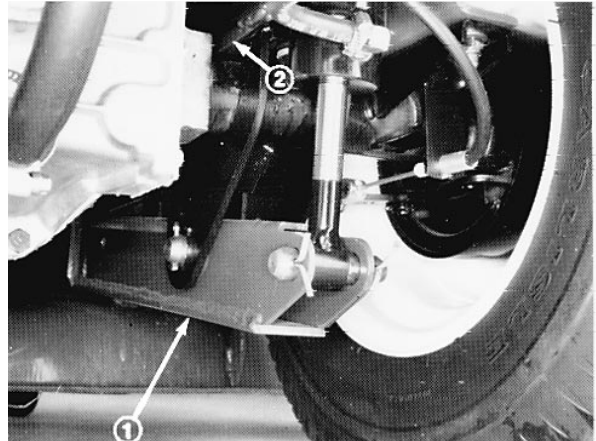

Figure 13

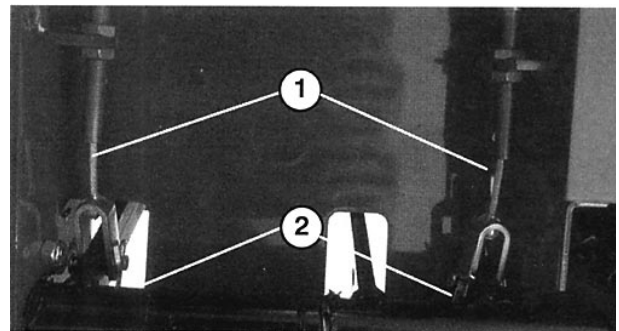

Figure 14

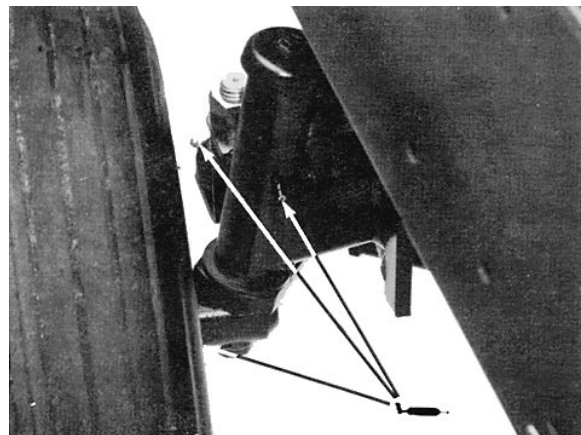

Figure 15

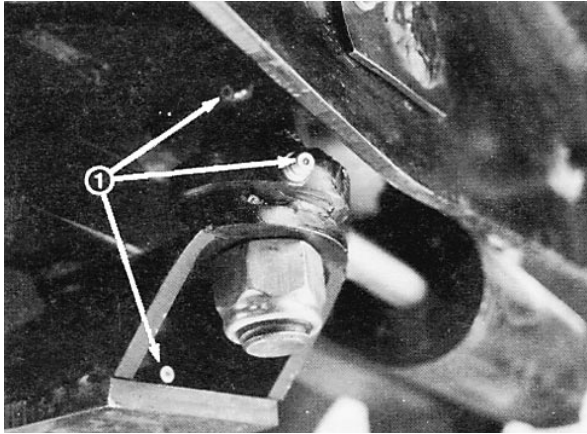

Figure 16

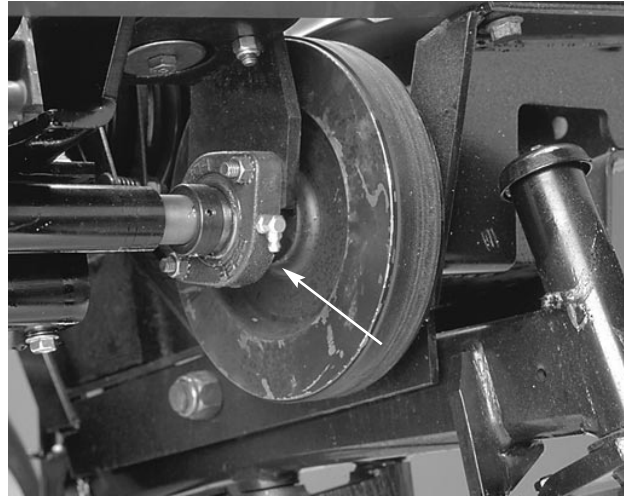

Figure 18

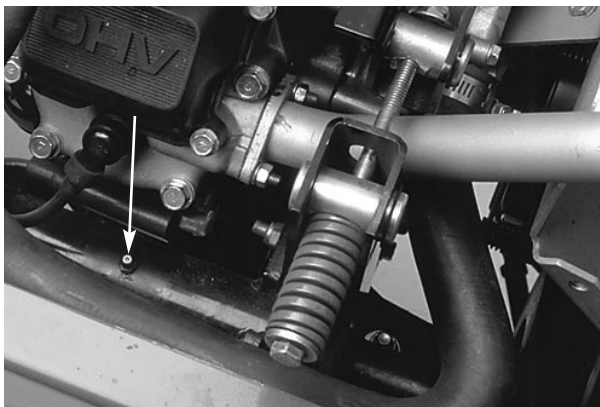
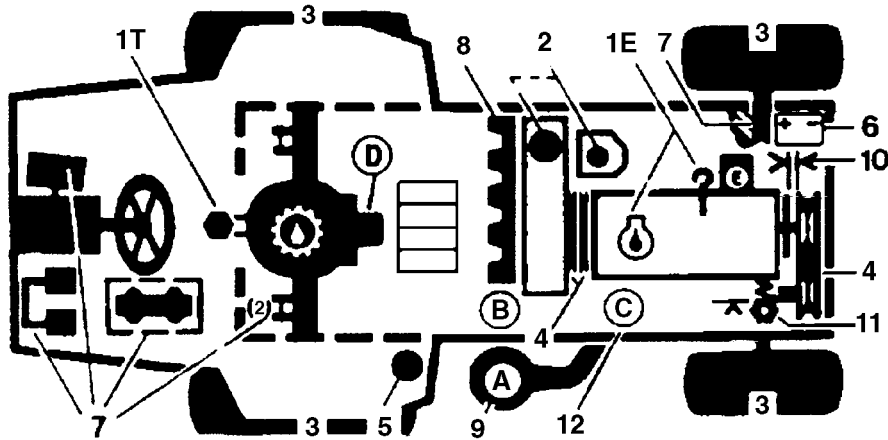

Figure 17

Quick Reference



- | | |
|------------------|-----------------------------------|
| 1. Oil levels | 7. Grease, Lube points |
| 2. Coolant level | 8. Radiator screen |
| 3. Tire Pressure | 9. Air cleaner |
| 4. Belts | 10. Electric clutch gap .-15-.030 |
| 5. Fuel—Gas Only | 11. PTO belt tension |
| 6. Battery | |

	TYPE >0° C	TYPE <0° C	CAPACITY	CHANGE INTER-VALS	
Engine oil	SAE 30 SE-SF	SAE 10W-30—10W40	1.5 L	oil 50 hours	filter 100 hours
Trans oil	SAE 10W-30—10W40	Type F or FA Transmission Fluid	5.7 L		filter 200 hours
Fuel	Unleaded gasoline		32.2 L	—	filter 400 hours
Coolant	50/50 Mix of Ethylene	glycol anti-freeze/water	3.8 L	2 years	

Daily Maintenance Checklist

- | | |
|---------------------------------------|--|
| 1. Safety Interlock operation | 9. Hydraulic hoses for damage |
| 2. Grass deflector in down position | 10. Fluid leaks |
| 3. Brake operation | 11. Tire pressure |
| 4. Engine oil level | 12. Instrument operation |
| 4. Cooling system fluid level | 13. Lubricate all Grease fillings ¹ |
| 5. Air filter | 14. Touch-up damaged paint |
| 6. Radiator & screen for debris | |
| 7. Unusual engine noises ¹ | |
| 8. Transmission oil level | |

¹= Immediately after every washing, regardless of the interval listed

Minimum Recommended Maintenance Intervals

Maintenance Procedure	Maintenance Interval & Service			
<div style="border: 1px solid black; padding: 5px; margin-bottom: 10px;"> <ul style="list-style-type: none"> Check battery fluid level Check battery cable connections Lubricate all grease fittings Lubricate brake cables Check cutting unit gear box oil level Clean under cutting unit belt covers Check cutting unit drive belt adjustment ✓✓Change engine oil Service air filter </div> <div style="border: 1px solid black; padding: 5px; margin-bottom: 10px;"> <ul style="list-style-type: none"> ✓✓Change the engine oil filter Check electric clutch gap adjustment ✓Check PTO belt tension Inspect cooling system hoses </div> <ul style="list-style-type: none"> Service air filter Replace fuel filter Check rear wheel toe-in and steering linkage ✓Charge transmission filter ✓Torque the wheel lug nuts 	Every 50 hours	Every 100 hours	Every 200 hours	Every 400 hours
<ul style="list-style-type: none"> Drain and clean fuel tank Replace cutting unit gear box oil Pack rear wheel bearings Coat transmission bypass pins with grease ✓✓Torque head, adjust valves and check engine RPM 				
<ul style="list-style-type: none"> ✓Initial break in at 10 hours ✓✓Initial break in at 80 hours 				
<ul style="list-style-type: none"> Replace moving hoses Replace safety switches Flush the cooling system and replace fluid Replace hydraulic oil 	<p>Annual Recommendations: Items are recommended every 1000 hours or two years, whichever occurs first.</p>			

AIR CLEANER MAINTENANCE

Clean the air cleaner foam element after every 50 operating hours. Clean more often when operating the mower in dusty or dirty conditions.

1. Remove the wing nuts securing the air cleaner cover and remove it (Fig. 19). Clean the cover thoroughly .

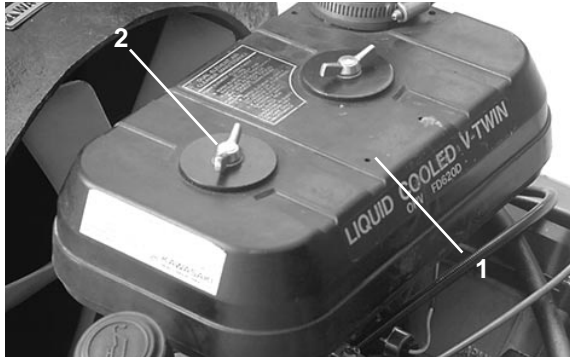

Figure 19

1. Air cleaner cover
2. Wing nuts

2. If the foam element (Fig. 20) is dirty, remove it from the paper element. Clean it thoroughly.

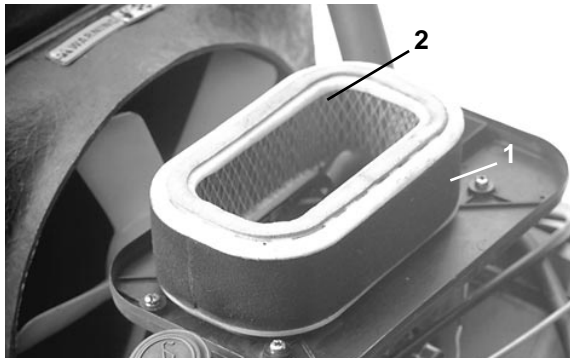

Figure 20

1. Foam
2. Paper

- A. WASH the foam element in a solution of liquid soap and warm water. Squeeze to remove dirt, but do not twist the element because it may tear.
- B. DRY the foam element by wrapping it in a clean cloth. Squeeze the cloth and foam element to dry.
- C. SATURATE the element with clean engine oil. Squeeze the element to remove excess oil and to distribute oil thoroughly. An oil damp element is desirable.

3. When servicing the foam element, check the condition of paper element (Fig. 26). Clean by gently tapping the element to remove dust. Replace element yearly or every 200 hours.
4. Install the foam element, paper element and air cleaner cover.

IMPORTANT: Do not operate the engine without the air cleaner element because extreme engine wear and damage will likely result.

CLEANING THE RADIATOR, OIL COOLER AND SCREEN

Normally, check the radiator screen, oil cooler and front of radiator daily and, if necessary, clean any debris from these parts. Check and clean components more frequently in extremely dusty and dirty conditions.

Note: If the engine shuts off due to overheating, first check the radiator and screen for excessive buildup of debris.

To thoroughly clean the radiator:

1. Remove the screen.
2. Working from the fan side of the radiator, either spray the radiator with a water hose or blow it with compressed air.
3. After the radiator is thoroughly cleaned, clean out debris that may have collected in the channel at the radiator base.
4. Clean and install the screen.

CHANGING THE ENGINE OIL AND FILTER

Check the oil level after each day's operation or each time machine is used. Change oil after the first 8 hours and after every 50 hours of operation thereafter. Change the oil filter after every 100 hours of operation. If possible, run the engine just before changing oil because warm oil flows better and carries more contaminants than cold oil.

1. Position the machine on a level surface.
2. Set a drain pan under the oil pan and in line with the drain plug (Fig. 21).
3. Clean the area around the drain plug.

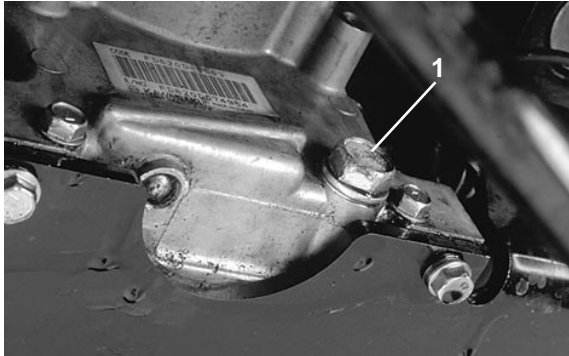

Figure 21

1. Oil drain plug

4. Remove the oil drain plug and allow oil to flow into the drain pan.
5. Remove and replace the oil filter (Fig. 22); refer to the parts catalog for the part number.



Figure 22

1. Oil filter

6. After the oil has drained, install the drain plug and wipe up any oil that is spilled.
7. Fill the crankcase with oil; refer to *Check The Engine Oil*.

SERVICING THE FUEL SYSTEM

Fuel Tank

Drain and clean fuel if the tank becomes contaminat-

ed or the machine is to be stored for an extended period. Use clean solvent to flush out the tank.

Fuel Lines and Connections

Check lines and connections every 400 hours or yearly, whichever comes first. Inspect for deterioration, damage or loose connections.

Fuel Filter

Clean the fuel filter after every 50 hours or yearly, whichever comes first.

1. Clamp both fuel lines that connect to the fuel filter (Fig. 23) so gasoline cannot drain when the lines are removed.
2. Loosen the clamp securing the fuel filter to the frame.

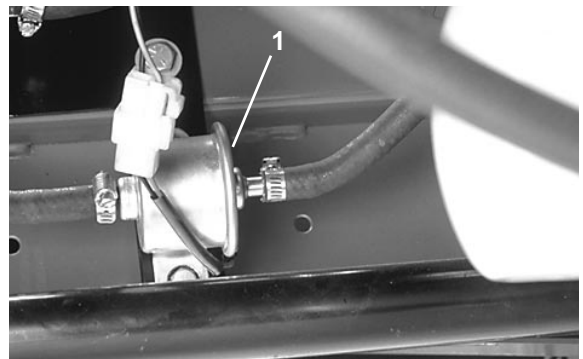

Figure 23

1. Fuel filter

3. Loosen the hose clamps (Fig. 23) at each end of the filter. Pull off the fuel lines and discard the filter.
4. Be sure the arrow on the side of the filter points toward the carburetor. Slide the hose clamps onto the ends of fuel lines and push the fuel lines onto the fuel filter.
5. Tighten the clamps.

CHECKING AND REPLACING SPARK PLUGS

Since the air gap between the center and side electrodes increases gradually during normal engine operation, check the condition of electrodes at 100-

hour intervals. The correct spark plugs to use are NGK BMR 6A or equivalent. Set the air gap at .024–.028 in.

1. Clean the area around the spark plugs so dirt does not fall into the cylinders when the plugs are removed.
2. Pull the wires off the spark plugs and remove the plugs from the cylinder head.



Figure 24

1. Spark plug wire

3. Check the condition of the center and side electrodes to determine the operating temperature of engine:
 - A. A light brown insulator tip indicates correct spark plug and heat range.
 - B. A black or oily insulator tip indicates an excessively rich fuel mixture, possibly caused by a dirty air cleaner element or a carburetor that is set too rich.
 - C. A light gray or blistered white insulator indicates overheating caused by a lean carburetor setting or incorrect spark plug (heat range too high).

IMPORTANT: A cracked, fouled or dirty spark plug must be replaced. Do not sandblast, scrape or clean electrodes by using a wire brush because grit may release from the plug and enter the combustion chamber, resulting in engine damage.

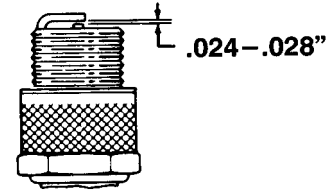

Figure 25

4. After setting the air gap at .024–.028", install spark plug in cylinder head. Tighten plugs to 23 Nm. Push the wires onto the spark plugs.

SERVICING THE PTO BELT

Check the tension of belt initially after the first day of operation and every 100 hours thereafter.

To Check PTO Belt Tension:

1. Turn the engine off and remove the ignition key. Set the parking brake. Raise the engine hood and let the engine cool.
2. Loosen the tensioning rod jam nut (Fig. 26).
3. Adjust the spring to a length of 1.9" (4.8 cm).
4. Tighten the jam nut.

To Replace The PTO Belt:

1. Turn off the engine and remove the ignition key. Set the parking brake. Raise the hood and allow the engine to cool.
2. Loosen the tensioning rod jam nut (Fig. 26).
3. Loosen the belt tensioning spring (Fig. 26) all the way.
4. Rotate PTO pulley toward the engine and remove the belt (Fig. 27).
5. Install the new PTO belt and re-tension the pulley spring to 1.9" (Fig. 26).
6. Tighten the jam nut (Fig. 27) and close the hood.

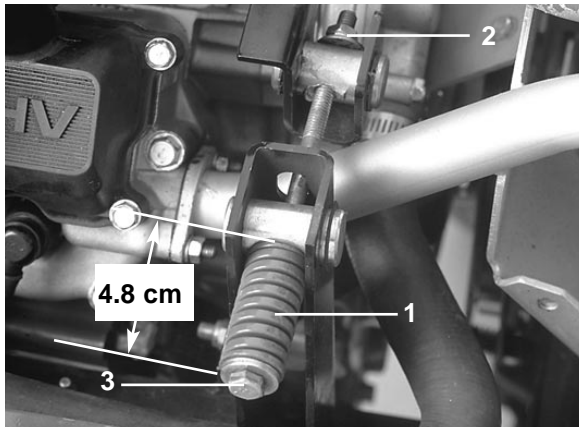

Figure 26

1. Tensioning spring
2. Tensioning rod jam nut
3. Tension adjusting bolt

PTO CLUTCH ADJUSTMENT

The power take off electric clutch can be adjusted as follows:

1. Turn the engine off and remove the ignition key. Set the parking brake. Raise the engine hood and allow the engine to cool.
2. Remove the bolt and nut securing the nylon block and remove the nylon block (Fig. 27).

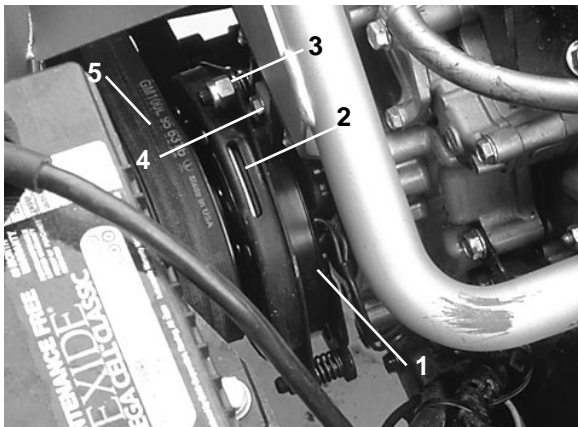

Figure 27

1. Clutch
2. .015" air gap (3)
3. Adjusting nut (3)
4. Nylon block
5. PTO belt

3. Unplug the clutch's electric connector.
4. Adjust the air gap so that a .015 inch feeler gauge slides between the clutch lining and friction plate with light pressure (Fig. 27). The gap

can be decreased by turning the adjusting nut clockwise (Fig. 26).

5. Rotate the clutch by hand and adjust all three air gaps. After all three gaps have been set, check all three again. (Adjusting one gap can alter the other gaps.)
6. Install the nylon block with a nut and bolt. Reconnect the clutch's electrical connector.

CHANGING COOLANT

The cooling system must be filled with a 50/50 solution of water and permanent ethylene glycol anti-freeze. After every two years, drain the coolant from the radiator, reservoir expansion tank and engine by opening the drain cock and block plug. After coolant is drained, flush the entire system and refill it with a 50/50 solution of water and anti-freeze. Cooling system is approximately 3.8 l. Fill the radiator completely and fill the expansion tank to between the capacity marks. **DO NOT OVERFILL.** Always install the radiator cap securely.



CAUTION

If the engine has been running, pressurized hot coolant can escape when the radiator cap is removed and cause burns.

ADJUSTING THE TRANSMISSION FOR NEUTRAL

The machine must not creep when the traction pedal is released. If it does creep, an adjustment is required.

1. Park the machine on a level surface and shut off the engine. Depress only the right brake pedal and engage the parking brake.
2. Jack up left front side of machine until the tire is off the shop floor. Support the machine with jack stands to prevent it from falling accidentally.
3. Lift the seat. Visually inspect the traction linkage for possible binding condition, correct if necessary and check machine operation. If the

condition still exists, repeat steps 1 and 2, then and go to step 4.

4. Loosen the two locknuts securing the pump plate so the plate is free to move (Fig. 28).
5. Start the engine and rotate the pump plate (Fig. 28) in either direction until the wheel ceases rotation.
6. Stop the engine and tighten the locknuts to secure the pump plate (Fig. 28).
7. Start the engine and check adjustment. Repeat

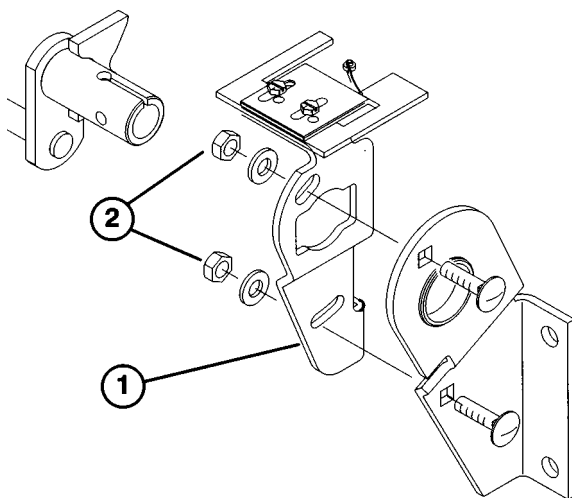

adjustment, if necessary.

Figure 28

1. Pump plate
2. Locknuts

8. Stop the engine and release the right brake. Remove the jack stands and lower the machine to the shop floor. Test drive the machine to be sure it does not creep.

CHANGING THE TRANSMISSION FILTER

Initially, replace the transmission filter after the first full day's operation—NOT TO EXCEED 10 HOURS. Replace the oil and filter every 200 hours thereafter. The hydraulic system is designed to operate on any high-quality detergent oil having the American Petroleum Institute—API—"service classification" SF/CC or CD. Oil viscosity—weight—must be selected according to anticipated ambient

temperature for the season in which you will use the 1000L.

Temperature/viscosity recommendations are:

Expected Ambient Temperature	Recommended Viscosity and Type
(Extreme) over 32° C	SAE 30, Type SF/CC or CD engine oil
(Normal) 4°–38° C	SAE 10W-30 or 10W-40 Type SF/CC or CD engine oil
(Cool—Spring/Fall) –1°–10° C	SAE 5W-30, Type SF/CC or CD engine oil.
(Winter) Below –1° F	Type "F" or "FA" ATF Automatic Transmission Fluid.

NOTE: Do not mix engine oil and automatic transmission fluid or hydraulic component damage may result. When changing fluids, also change the transmission filter. DO NOT USE DEXRON II ATF.

NOTE: Fluid to operate the power steering is supplied by the hydraulic system transmission charge pump.

Cold weather start-up may result in "stiff" operation of the steering until the hydraulic system has warmed up. Using proper weight hydraulic oil in system will minimize this condition.

The axle housing acts as the reservoir for the system. The transmission and axle housing are shipped from the factory with approximately 4.7 l of SAE 10W-30 engine oil. However, check level of transmission oil before you first start the engine and daily thereafter.

1. Lower the cutting unit to the shop floor, set the parking brake, and turn the engine OFF. Block the two rear wheels.
2. Jack up both sides of the front axle and support it with jack stands.
3. Clean the area around the hydraulic oil filter and remove the filter (Fig. 29).
4. Remove the tube that connects the axle housing to the transmission and allow the oil to flow

into a drain pan.

5. Install the new hydraulic oil filter and connect the tube between axle housing and transmission. Fill the axle (reservoir) to proper level (approx. 4.7 qt); refer to *Check Hydraulic System Fluid*. Remove the jack stands.
6. Start the engine, cycle the steering and lift cylinders, and check for oil leaks. Allow the engine to run for about five minutes. Then shut off the engine.

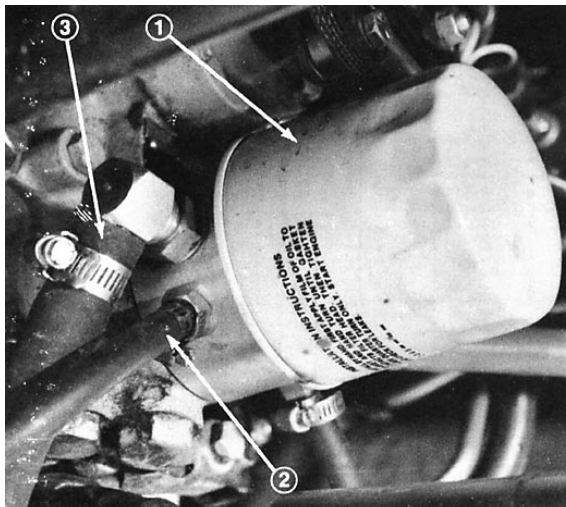

Figure 29

1. Hydraulic system filter
2. Hydraulic return lines
3. Suction line

ADJUSTING THE SERVICE BRAKES

Adjust the service brakes when there is more than one inch of "free travel" of the brake pedals, or when the brakes do not work effectively. (Free travel is the distance the brake pedal moves before braking resistance is felt.)

The brakes should be checked for adjustment after the first 50 hours of operation and then should only need adjustment after considerable use. These periodic adjustments can be performed where the brake cable connect to the bottom of the brake pedals. When the cable is no longer adjustable, the star nut

on the inside of the brake drum must be adjusted to move the brake shoes outward. However, the brake cables must be adjusted again to compensate for this adjustment.

1. Disengage the lock arm from the right brake pedal so both pedals work independently of each other.
2. To reduce free travel of the brake pedals—tighten the brakes—loosen the front nut on the threaded end of the brake cable (Fig. 30). Then

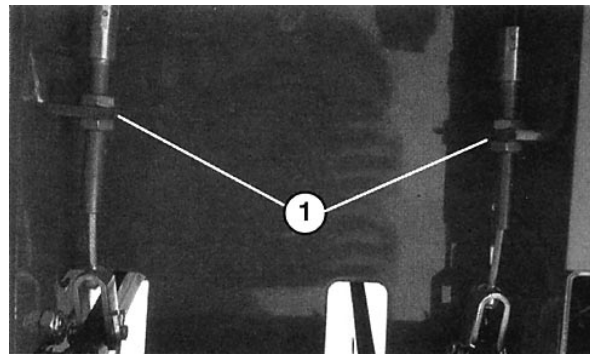

tighten the rear nut to move the cable backward until the brake pedals have 13 mm to 25 mm (1/2 to 1 inch) of free travel. Tighten the front nut after the brakes are adjusted correctly.

Figure 30

1. Jam nuts

SERVICING THE BATTERY

IMPORTANT: Before welding on the machine, disconnect the ground cable from the battery to prevent damage to the electrical system.

Note: Check battery condition weekly or after every 50 hours of operation. Keep the terminals and entire battery case clean because a dirty battery will slowly discharge. To clean the battery, wash the entire case with a solution of baking soda and water. Rinse with clear water. Coat the battery posts and cable connector with Grafo 11 2X (Skin-over) grease, Toro Part No. 505-47 or petroleum jelly to prevent corrosion.

WIRING HARNESS SERVICE

Prevent corrosion of wiring terminals by applying Grafo 112X (Skin-over) grease, Toro Part No. 505-47, to the inside of all harness connectors whenever the harness is replaced.

Whenever working with the electrical system, always disconnect the battery cables, negative (–) cable first, to prevent possible wiring damage from electrical shorts.

FUSES

The fuse block is accessible under the seat plate (Fig. 31).

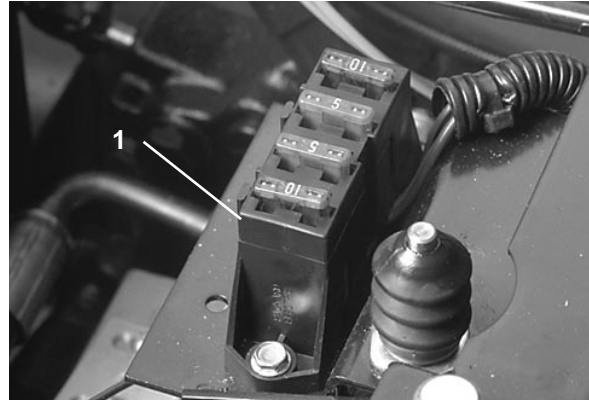

Figure 31

1. Fuse block

Preparation for Seasonal Storage

Traction Unit

1. Thoroughly clean the traction unit, cutting unit and the engine, paying special attention to these areas:
 - radiator and radiator screen
 - underneath the cutting unit
 - under the cutting unit belt covers
 - counterbalance springs
 - P.T.O. Shaft Assembly
 - all grease fittings and pivot points
 - remove control panel and clean out the inside of the control box
 - beneath seat plate and top of transmission
2. Check the tire pressure. Inflate all traction unit tires to 20 psi.
3. Remove, sharpen and balance the cutting unit's blades. Reinstall the blades and torque the blade fasteners to 85–110 ft-lb (115–149 Nm).
4. Check all fasteners for looseness; tighten as necessary.
5. Grease or oil all grease fittings, pivot points, and

transmission by-pass valve pins. Wipe off any excess lubricant.

6. Lightly sand and use touch up paint on painted areas that are scratched, chipped or rusted. Repair any dents in the metal body.
7. Service the battery and cables as follows:
 - a. Remove the battery terminals from the battery posts.
 - b. Clean the battery, terminals and posts with a wire brush and baking soda solution.
 - c. Coat the cable terminals and battery posts with Grafo 112X skin-over grease (Toro Part Number 505-47), or petroleum jelly to prevent corrosion.
 - d. Slowly recharge the battery for 24 hours every 60 days to prevent lead sulfation of the battery.

Engine

1. Drain the engine oil from the oil pan and replace the drain plug.
2. Remove and discard the oil filter. Install a new filter.

3. Refill the engine with 3.8 quarts (3.6 l) of recommended motor oil. Refer to *Changing Crankcase Oil*.
4. Start the engine and run at idle speed for two minutes.
5. Drain gasoline from the fuel tank, fuel lines, pump, filter and separator. Flush the fuel tank with clean solvent and connect all fuel lines.
6. Thoroughly clean and service the air cleaner assembly.
7. Seal the air cleaner inlet and the exhaust outlet with weather proof masking tape.
8. Check the oil filler cap and fuel tank cap to ensure they are securely in place.

PRODUCT IDENTIFICATION

The traction unit has two identification numbers: a model number and a serial number that are stamped into a plate. The identification plate is located near the left brake pedal on the frame (Fig.). In any correspondence concerning the traction unit, supply the model and serial numbers to ensure correct information and replacement parts are obtained.

To order replacement parts from an Authorized TORO Distributor supply the following information:

1. Model and serial numbers of the traction unit.
2. Part number, description and quantity of parts desired.

Note: Do not order by reference number if a parts catalog is being used; use the part number.



Figure 32

1. Model and serial ID plate

