



MODEL NO. 08884—70001 & OVER MODEL NO. 08885—70001 & OVER	OPERATOR'S MANUAL
SAND PRO® 2020 & 3020	



To understand this product, and for safety and optimum performance, read this manual before starting operation. Pay special attention to **SAFETY INSTRUCTIONS** highlighted by this symbol.



FOREWORD

The SAND PRO was developed to provide an efficient, trouble free and economical method of sand trap maintenance. The latest concepts of engineering, design and safety have been incorporated into this machine, along with the highest quality parts and workmanship. Excellent service will be derived if proper operation and maintenance practices are followed.

You know, since you have purchased the industry leader in sand trap and other maintenance excellence, that future performance and dependability are of prime importance. TORO also is concerned about future use of the machine and of safety to the user. Therefore, this manual must be read by you and those involved with the SAND PRO to make sure that safety, proper set—up, operation and maintenance procedures are followed at all times. The major sections of the manual are:

Safety, mechanical and some general information in this manual are emphasized. DANGER, WARNING and CAUTION identify safety messages. Whenever the triangle safety symbol appears, it is followed by a safety message that must be read and understood. For more details concerning safety, read the safety instructions on pages 4 and 5. IMPORTANT identifies special mechanical information and NOTE identifies general information worthy of special attention.

If help concerning set up, operation, maintenance or safety is ever needed, contact your local Authorized TORO Distributor. In addition to genuine TORO replacement parts, the distributor also has optional equipment for the complete line of TORO turf care equipment. Keep your Toro all TORO. Buy genuine TORO parts and accessories.

Table of Contents

SAFETY INSTRUCTIONS	3-4	Changing Crankcase Oil	13
SYMBOL GLOSSARY	5	Servicing Air Cleaner	14
SPECIFICATIONS	6	Adjusting Throttle Control	15
BEFORE OPERATING	7-8	Adjusting Choke Control	15
Check Crankcase Oil	7	Checking Spark Plug	15
Fill the fuel Tank	7	Cleaning Cylinder Head Fins	16
Check Hydraulic System	8	Changing Hydraulic System Oil and Filter	16
Check Tire Pressure	8	Checking Hydraulic Lines and Hoses	16
KNOW YOUR CONTROLS	9-10	Battery Storage	17
OPERATING INSTRUCTIONS	10-11	Battery Care	17
Starting/Stopping Engine	10	IDENTIFICATION AND ORDERING	17
Check Interlock System	11	WARRANTY	18
Towing Sand Pro	11		
Break-in Period	11		
Operating Characteristics	11		
Inspection and Clean-Up	11		
MAINTENANCE	12-16		
Lubrication	13		

Safety

The SAND PRO was designed and tested to offer safe service when operated and maintained properly. Although hazard control and accident prevention partially are dependent upon the design and configuration of the machine, these factors are also dependent upon the awareness, concern, and proper training of the personnel involved in the operation, transport, maintenance, and storage of the machine. Improper use or maintenance of the machine can result in injury or death. To reduce the potential for injury or death, comply with the following safety instructions.

BEFORE OPERATING

1. Operate the machine only after reading and understanding the contents of this manual.
 2. Never allow children to operate the machine or adults to operate it without proper instructions.
 3. Become familiar with the controls and know how to stop the engine quickly.
 4. Keep all shields, safety devices and decals in place. If a shield, safety device or decal is malfunctioning, illegible, or damaged, repair or replace it before operating the machine.
 5. Always wear substantial shoes. Do not operate machine while wearing sandals, tennis shoes or sneakers. Do not wear loose fitting clothing which could get caught in moving parts and cause personal injury.
 6. Wearing safety glasses, safety shoes, long pants and a helmet is advisable and required by some local safety and insurance regulations.
 7. Ensure the traction interlock switch is adjusted correctly so the engine cannot be started unless the traction pedal is released and in neutral position.
 8. Keep everyone, especially children and pets away from the areas of operation.
 9. Since gasoline is highly flammable, handle it carefully.
 - A. Use an approved gasoline container.
 - B. Do not remove the cap from the fuel tank when the engine is hot or running.
 - C. Do not smoke while handling gasoline.
 - D. Fill the fuel tank outdoors and to about one inch below the top of the tank, (bottom of filler neck). Do not overfill.
 - E. Wipe up any spilled gasoline.
10. Check the safety interlock system daily for proper operation. If the switch should malfunction, replace it before operating the machine. (After every two years, replace the interlock switch in the safety system, whether it is working properly or not.)

WHILE OPERATING

11. Exhaust fumes are hazardous and could be deadly, so do not run the engine in a confined area without adequate ventilation.
12. Sit on seat when operating the machine. Never carry passengers.
13. When starting the engine:
 - A. Make sure the traction pedal is released.
 - B. After the engine is started, keep your foot off the traction pedal. Machine must not move. If movement is evident, the neutral return bracket is adjusted incorrectly; therefore, shut the engine off and readjust bracket so machine does not move when in neutral position. If the engine does not start, check interlock switch for proper adjustment.
14. Using the machine demands attention. To prevent tipping or loss of control:
 - A. Use care when entering and leaving sand traps. Use extreme caution around ditches, creeks or other hazards.
 - B. Watch for holes or other hidden hazards.
 - C. Use caution when operating machine on a steep slope. Reduce speed when making sharp turns or when turning on hillsides.
 - D. Avoid sudden stops and starts. Do not go from reverse to full forward without first coming to a complete stop.
 - E. Before backing up, look to the rear and assure no one is behind the machine.

- F. Watch out for traffic when near of crossing roads. Always yield the right of way.
 - 15. If the optional Draw Bar, Part No. 230, is installed on machine, vertical load on the hitch should not exceed 200 lbs.
 - 16. Do not touch the engine, muffler or exhaust pipe while the engine is running or soon after it has stopped because these areas are hot enough to cause burns.
 - 17. If the machine ever vibrates abnormally, stop immediately, turn the engine off, wait for all motion to stop and inspect for damage. Repair all damage before commencing operation.
 - 18. Before getting off the seat:
 - A. Engage the parking brake and lower the attachment. Take precautions to prevent accidental starts, rolling away, etc.
 - B. Shut the engine off and wait for all movement to stop.
 - 19. Whenever machine is left unattended, be sure the engine is stopped, implement is lowered and the key is removed from the ignition.
- 24. To make sure entire machine is in good condition, keep all nuts, bolts and screws properly tightened.
 - 25. If major repairs are ever needed or assistance is required, contact an Authorized TORO Distributor.
 - 26. To reduce potential fire hazard, keep the engine area free of excessive grease, grass, leaves and accumulation of dirt.
 - 27. If the engine must be running to perform a maintenance adjustment, keep hands, feet, clothing, and any parts of the body away from the engine and any moving parts. Keep everyone away.
 - 28. Do not overspeed the engine by changing governor settings. Maximum engine speed is 3200 rpm. To assure safety and accuracy, have an Authorized Toro Distributor check maximum engine speed with a tachometer.
 - 29. Engine must be shut off before checking oil or adding oil to the crankcase.
 - 30. To be sure of optimum performance and safety, always purchase genuine TORO replacement parts and accessories. Replacement parts and accessories made by other manufacturers could be dangerous. Such use could void the product warranty of The Toro Company.

MAINTENANCE

- 20. Before servicing or making adjustments to the machine, stop the engine and pull the spark plug wire off spark plug to prevent accidental starting of the engine.
- 21. Make sure all hydraulic line connectors are tight, and all hydraulic hoses and lines are in good condition before applying pressure to the system.
- 22. Keep body and hands away from pin hole leaks or nozzles that eject hydraulic fluid under high pressure. Use paper or cardboard, not hands, to search for leaks. Hydraulic fluid escaping under pressure can have sufficient force to penetrate skin and do serious damage. If fluid is injected into the skin it must be surgically removed within a few hours by a doctor familiar with this form of injury or gangrene may result.
- 23. Before disconnecting or performing any work on the hydraulic system, all pressure in system must be relieved by stopping the engine and lowering

Sound & Vibration Levels

Sound Levels

This unit has an equivalent continuous A-weighted sound pressure at the operator ear of: 83 dB(A), based on measurements of identical machines per 84/538/EEC.

Vibration Levels

This unit has a vibration level of 2.5 m/s² at the posterior, based on measurements of identical machines per ISO 5349 procedures.

This unit does not exceed a vibration level of 0.5 m/s² at the posterior based on measurements of identical machines per ISO 5349 procedures.

Symbol Glossary

SAFETY ALERT SYMBOL	GENERAL HAZARD SAFETY ALERT	STORED ENERGY HAZARD, KICKBACK OR UPWARD MOTION	HOT SURFACE, BURNS TO FINGERS OR HANDS	MACHINE TIPPING	RUNOVER/BACKOVER	CRUSHING OF TOES OR FOOT, FORCE APPLIED FROM ABOVE		
DO NOT REMOVE OR REMOVE SAFETY SHIELDS WHILE ENGINE IS RUNNING	CAUSTIC LIQUIDS, CHEMICAL BURNS TO FINGERS OR HANDS	STAY A SAFE DISTANCE FROM MACHINE	STAY A SAFE DISTANCE FROM MACHINE	STAY A SAFE DISTANCE FROM MACHINE	KEEP CHILDREN A SAFE DISTANCE FROM BATTERY			
EXPLOSION	FIRE OR OPEN FLAME	FIRE, OPEN LIGHT & SMOKING PROHIBITED	EYE PROTECTION MUST BE WORN	CAUTION, TOXIC RISK	FIRST AID	FLUSH WITH WATER		
ENGINE START	ENGINE STOP	ON START	OFF STOP	FAST	SLOW	CONTINUOUS VARIABLE LINEAR		
LOCK	UNLOCK	HYDRAULIC OIL	HEADLIGHTS	CHOKE	ATTACHMENT RAISE	ATTACHMENT LOWER		
PARK	FORWARD	REVERSE	NEUTRAL	CONTROL LEVER OPERATING DIRECTION, DUAL DIRECTION	TRACTION PEDAL OPERATION	DO NOT DISPOSE IN THE GARBAGE	BATTERY CHARGING CONDITION	READ OPERATOR'S MANUAL
STEERING WHEEL LOCK OPERATION	STEERING WHEEL TILT OPERATION	USE CAUTION WHEN OPERATING UNIT ON A STEEP SLOPE	DO NOT TOW	NEVER PARK UNIT ON A SLOPE. BEFORE LEAVING OPERATOR POSITION, MOVE TRACTION PEDAL TO NEUTRAL, LOWER IMPLEMENTS TO GROUND, TURN IGNITION KEY TO "OFF" POSITION & REMOVE KEY.				

Specifications

Configuration: Short-wheelbase tricycle vehicle with mid engine placement. Rear wheels powered. Front wheel steering. Operator positioned centrally.

Engine: Briggs & Stratton, V-twin cylinder, 4-cycle OHV, air-cooled, gas engine with cast iron sleeves. 11.9 KW (16 hp) @ 3600 rpm, 29.3 cu. in. (480 cc) displacement. 1.7 l oil capacity. Electronic ignition. Full-pressure lubrication, oil filter. Engine and remote-mounted air cleaners.

Instrumentation: Hour meter.

Gas Tank: 16.1-liter capacity.

Battery: 12-volt, lead acid, 32-amp hour.

Drive: Hydraulic. Coupling driven variable displacement piston pump with integral auxiliary charge pump to geroller motors, which directly drive rear wheels.

Hydraulic Oil Filter: 25-micron, spin-on type.

Hydraulic Oil Reservoir: 11.4 l capacity.

Valve: Single section for raising and lowering of the implement.

Cylinder: Double acting.

Wheel Bearings: Needle bearing in each wheel motor.

Tires: 21 x 11.00-8 two-ply pneumatic tubeless. Demountable and interchangeable. Recommended tire pressure is 27 kPa.

Speeds (at 3200 RPM): Variable between 0 and 14.58 kmh forward and 0 and 6.4 kmh reverse.

Seat Adjustment: 10 cm fore and aft. Additional 4.4 cm forward adjustment available by using front mounting holes.

Dimensions:

Width w/o implement:	146 cm
Width w/ rake model 08812:	190.5 cm
Height:	114 cm
Length w/o rake:	193 cm
Net Weight (wet):	261 kg

Optional Equipment:

Drag Mat	Model 08850
Rake	Model No. 08811
Edger Kit	Model No. 08822
Rake Mounting Kit	Model No.08814
Tooth Rake Kit	Model No. 08812
Weeder Kit	Model No. 08815
Spring Rake Kit	Model No. 08813
Finish Grader	Model No. 08867
Spiker	Model No. 08856
Front Blade Kit	Model No. 08821
Cultivator Kit	Model No. 08818
Prong Rake Attachment	Part No. 42-3960
Draw Bar	Part No. 92-2380

Before Operating



CAUTION

Before servicing or making adjustments to the machine, stop the engine, pull wires off the spark plugs and remove the key from the switch.

CHECK CRANKCASE OIL (Fig. 1)

The engine is shipped with 1.7 l (with filter) of oil in the crankcase; however, check the level before and after the engine is first started.

1. Position the machine on a level surface.
2. Remove the engine cover.
3. Pull out the dipstick and wipe it with a clean cloth, then insert it fully back into the engine. Remove it and check the oil level. If oil is low, remove the filler cap (next to the dipstick) and add enough oil to raise the level to the FULL mark on the dipstick.

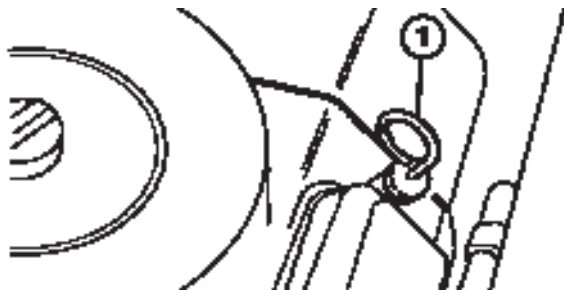

Figure 1

1. Dipstick

4. Use any high-quality detergent oil having the API classification SE, SF, or SG. Recommended viscosity is SAE 30.
5. Install the dipstick firmly in place.
6. Replace the engine cover.

IMPORTANT: The dipstick must be fully seated in the tube to properly seal the engine crankcase. Failure to seal the crankcase may result in engine damage.

IMPORTANT: Check the oil level every 8 operating hours or daily. Initially, change the oil

after the first 8 hours of operation; thereafter, under normal conditions, change the oil every 25 hours and the filter every 100 hours. However, change oil more often when operating the engine in extremely dusty or dirty conditions.

FILL THE FUEL TANK (Fig. 2)

THE TORO COMPANY STRONGLY RECOMMENDS THE USE OF FRESH, CLEAN, UNLEADED REGULAR GRADE GASOLINE IN TORO GASOLINE POWERED PRODUCTS. UNLEADED GASOLINE BURNS CLEANER, EXTENDS ENGINE LIFE, AND PROMOTES GOOD STARTING BY REDUCING THE BUILD-UP OF COMBUSTION CHAMBER DEPOSITS. LEADED GASOLINE CAN BE USED IF UNLEADED IS NOT AVAILABLE.

NOTE: Never Use Methanol, Gasoline Containing Methanol, Gasoline Containing More Than 10% Ethanol, Gasoline Additives, Premium Gasoline Or White Gas Because Engine Fuel System Damage Could Result.

Fuel tank capacity is 16.1 liters.



DANGER

Because gasoline is flammable, caution must be used when storing or handling it. Do not fill the fuel tank while the engine is running, hot or when the machine is in an enclosed area. Vapors may build up and be ignited by a spark or flame source many feet away.

DO NOT SMOKE while filling the fuel tank to prevent the possibility of an explosion. Always fill the fuel tank outside and wipe up any spilled gasoline before starting the engine. Use a funnel or spout to prevent spilling gasoline, and fill the tank no higher than one inch below the top of the tank (bottom of the filler neck). DO NOT OVER FILL.

Store gasoline in a clean safety approved container and keep the cap on the container. Keep gasoline in a cool, well-ventilated place; never in an enclosed area such as a hot storage shed. To assure volatility, do not buy more than a 30-day supply of gasoline. Gasoline is a fuel for internal combustion engines; therefore do not use it for any other purpose. Since many children like the smell of gas, keep it out of their reach because the fumes are explosive and dangerous to inhale.

1. Clean the area around the fuel tank cap.

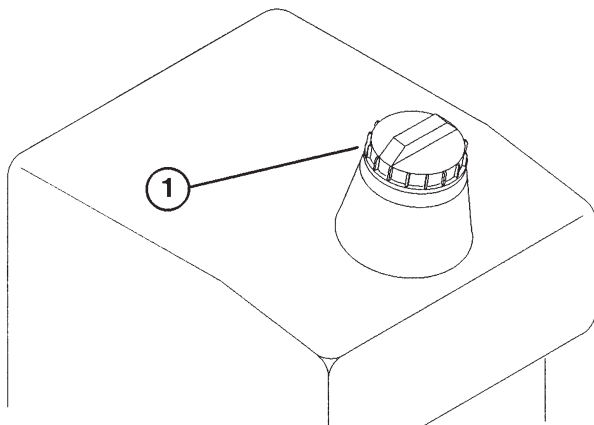

Figure 2

1. Fuel tank cap

2. Remove the fuel tank cap.
3. Fill the tank to about 3 mm below the top of the tank, (bottom of filler neck). DO NOT OVERFILL. Then install the cap.
4. Wipe up any fuel that may have spilled to prevent a fire hazard.

CHECK THE HYDRAULIC SYSTEM (Fig. 3)

The hydraulic system is designed to operate on Mobil 424 hydraulic oil. The machine's 11 liter reservoir is filled at the factory with oil. However, check the level of oil before the engine is first started and daily thereafter.

1. Remove the cap from the hydraulic oil reservoir.

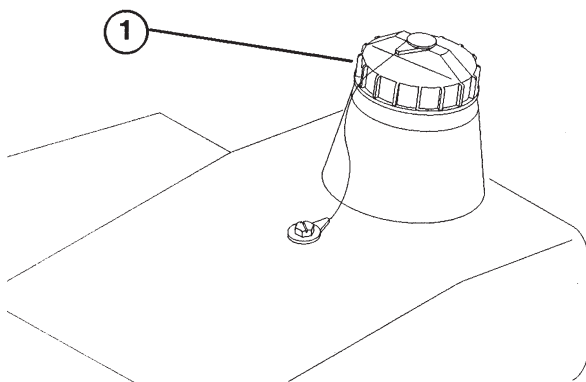

Figure 3

1. Oil reservoir cap

2. Check the level of oil in the reservoir. The oil level

should be up to the top of the cone point on the tank screen.

3. If the oil level is low, slowly fill the reservoir with appropriate hydraulic oil until the level is up to the top of cone point on the tank screen. DO NOT OVERFILL.

Group 1 Hydraulic Fluid (Recommended for ambient temperatures consistently below 100° F)

ISO type 46/68 anti-wear hydraulic fluid

Mobil	Mobile Fluid 424
Amoc	Amoco 1000
International Harvester	Hy-Tran
Texaco	TDH
Shell	Donax TD
Union Oil	Hydraulic/Tractor Fluid
Chevron	Tractor Hydraulic Fluid
BP Oil	BP HYD TF
Boron Oil	Eldoran UTH
Exxon	Torque Fluid
Conoco	Power-tran 3
Kendall	Hyken 052
Phillips	HG Fluid

4. Install the reservoir cap.

IMPORTANT: To prevent system contamination, clean the top of hydraulic oil containers before puncturing. Assure the pour spout and funnel are clean.

CHECK TIRE PRESSURE

Check tire pressure before operating the machine. Correct air pressure in the front and rear tires is 27–41kPa.

Controls

Traction and Stopping Pedal (Fig. 4-5)—The traction pedal has three functions: one, to make the machine move forward, two, to move it backward and three, to stop the machine. Using the heel and toe of your right foot, depress the top of the pedal to move forward and bottom of the pedal to move backward or to assist in stopping when moving forward. Also, allow the pedal to move or move it to the neutral position to stop the machine. For operator comfort, do not rest the heel of your foot on reverse when operating forward (Fig. 5).

Ground speed is proportionate to how far the traction pedal is depressed. For maximum ground speed, the pedal must be fully depressed while the throttle is in the FAST position. To get maximum power or when ascending a hill, have the throttle in the FAST position while depressing the pedal slightly to keep engine rpm high. When engine rpm begins to decrease, release the pedal slightly to allow rpm to increase.

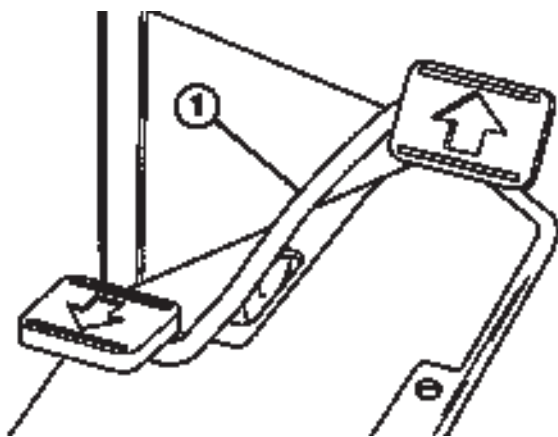

Figure 4

1. Traction and stopping pedal

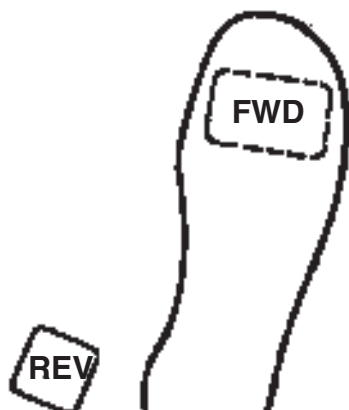

Figure 5

IMPORTANT: For maximum pulling power, the throttle should be in the “Fast” position, and the trac-

tion pedal just barely depressed.



CAUTION

Use the maximum ground speed ONLY when driving from one area to another. Maximum speed is not recommended when using an attached or towed implement.

IMPORTANT: The SAND PRO must not be operated in reverse with the implement in the down (operating) position, or the implement could be severely damaged.

Ignition Switch (Fig. 6)—The ignition switch, used to start and stop the engine, has three positions: OFF, RUN and START. Turn the key clockwise—START position—to engage the starter motor. Release the key when the engine starts. The key will move automatically to the ON position. To shut the engine off, turn the key counter-clockwise to the OFF position.

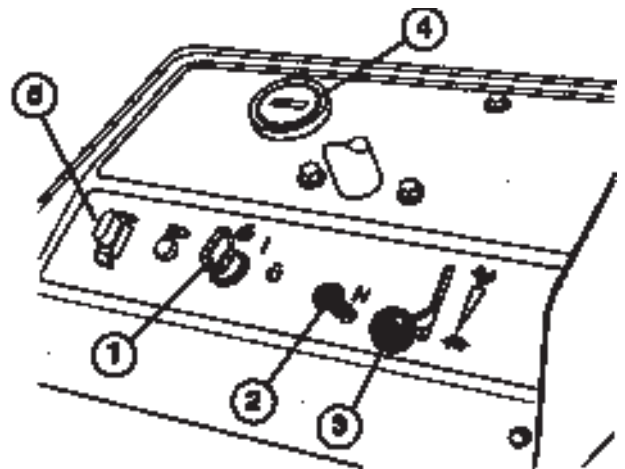

Figure 11

1. Ignition switch
2. Choke control
3. Throttle control
4. Hour meter
5. Fuse

Choke Control (Fig. 6)—To start a cold engine, close the carburetor choke by pulling the choke control out to the ON position. After the engine starts, regulate the choke to keep the engine running smoothly. As soon as possible, open the choke by pushing it downward to the OFF position. A warm engine requires little or no choking.

Throttle Control (Fig. 6)—Lever connects to and operates the throttle linkage to the carburetor. The throttle

control has two positions: SLOW and FAST. Engine speed can be varied between the two settings.

Note: The engine cannot be stopped by the throttle control.

Hour Meter (Fig. 6)—Shows the total hours of machine operation. The Hour Meter starts to function whenever the key switch is turned to the “ON” position.

Lift Lever (Fig. 7)—To raise the implement, pull the lever up; to lower the implement, push the lever forward. For float position, move the lever into the detent position. When the desired position is attained, release the lever and it will return to neutral.

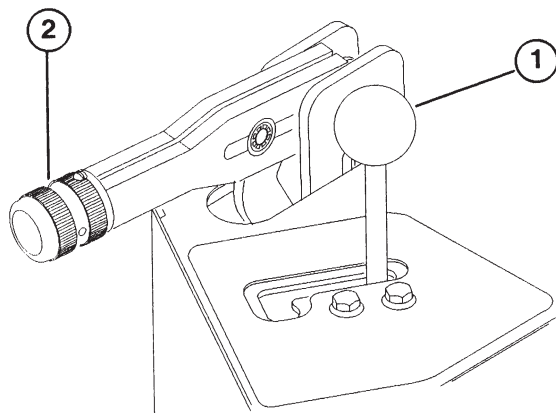

Figure 7

1. Lift lever
2. Parking brake

NOTE: The SAND PRO has a double-acting lift cylinder. Down pressure can be applied to the implement for certain operating conditions.

Parking Brake (Fig. 7)—To engage the parking brake, pull back on the lever. To disengage it, push the lever forward.

Fuel Shut-Off Valve (Fig. 8)— Close the fuel shut-off valve when storing the machine.

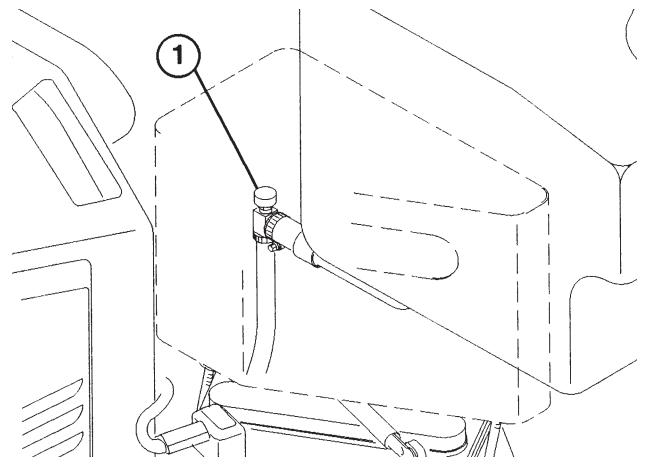

Figure 8

1. Fuel shut-off valve

Operating

STARTING/STOPPING THE ENGINE

1. Remove your foot from the traction pedal, make sure the pedal is in the neutral position and engage the parking brake.
2. Pull the choke lever out to the ON position—when starting a cold engine—and the throttle lever to the SLOW position.
3. Insert the key into the ignition switch and turn it clockwise to start the engine. Release the key when the engine starts. Regulate the choke to keep the engine running smoothly.

IMPORTANT: To prevent overheating of the starter motor, do not engage starter longer than

10 seconds. After 10 seconds of continuous cranking, wait 60 seconds before engaging starter motor again.

4. When the engine is started for the first time, or after overhaul of the engine, operate the machine in forward and reverse for one to two minutes. Also operate the lift lever to be sure of proper operation of all parts.

CAUTION

Shut off the engine and wait for all moving parts to stop before checking for oil leaks, loose parts and other malfunctions.

5. To stop the engine, move the throttle control to the

SLOW position and turn the ignition key to OFF. Remove the key from the switch to prevent accidental starting.

6. Close the fuel shut-off valve before storing the machine.

CHECK INTERLOCK SYSTEM OPERATION

The purpose of the interlock system is to prevent the engine from cranking or starting unless the traction pedal is in “NEUTRAL”.

1. Check interlock operation in a wide open area free of debris and bystanders. Stop the engine.
2. Sit on the seat. Depress the traction pedal in the forward and reverse directions, while trying to start the engine. If the engine cranks there may be a malfunction in the interlock system. Repair the system immediately. If the engine does not crank, the system is operating correctly.



CAUTION

The interlock switch is for the operator’s protection, so do not disconnect it. Check operation of the switch daily to assure the interlock system is operating. If the switch is defective, replace it before operating. Regardless of whether the switch is operating correctly, replace it every two years to assure maximum safety. Do not rely entirely on safety switches—use common sense.

TOWING THE SAND PRO

In case of emergency, the SAND PRO can be towed for a short distance. However, Toro does not recommend this as a standard procedure.

IMPORTANT: Do not tow the machine faster than 3–5 kmh because drive system may be damaged. If the machine must be moved a considerable distance, transport it on a truck or trailer. Tires may lock up if the machine is towed too fast. If this occurs, stop towing the machine and wait for traction circuit pressure to stabilize before resuming towing at a slower speed.

BREAK-IN PERIOD

1. Only 8 hours operating time is required for the SAND PRO break-in period.

2. Since the first hours of operation are critical to future dependability of the machine, monitor its functions and performance closely so that minor difficulties that could lead to major problems are noted and can be corrected. Inspect the SAND PRO frequently during break-in for signs of oil leakage, loose fasteners, or any other malfunction.

OPERATING CHARACTERISTICS

Practice driving the SAND PRO because its operating characteristics are different from those of other utility vehicles. Two points to consider when operating the vehicle are transmission and engine speed.

To maintain somewhat constant engine rpm, depress the traction pedal slowly. This allows the engine to keep up with ground speed of the vehicle. By contrast, pushing down quickly on the traction pedal will reduce engine rpm and, as a result, there will not be enough torque power to move the vehicle. Therefore, to transfer maximum power to the rear wheels, move the throttle to FAST and slightly depress the traction pedal.

By comparison, maximum ground speed with no load results when throttle is at FAST and the traction pedal is slowly but fully depressed. In summary, always keep engine rpm high enough to deliver maximum torque—power—to the rear wheels.



CAUTION

Using the machine demands attention. To prevent tipping or loss of control, use care when entering and leaving sand traps. Use extreme caution around ditches, creeks or other hazards. Use caution when operating the machine on a steep slope. Reduce speed when making sharp turns or when turning on hillsides. Avoid sudden stops and starts. Do not go from reverse to full forward without first coming to a complete stop.

INSPECTION AND CLEAN-UP

At the completion of operation, thoroughly wash the machine with a garden hose —without a nozzle—so excessive water pressure will not cause contamination and damage to seals and bearings.

Make sure cooling fins and the area around the engine cooling air intake are kept free of debris. After cleaning, inspect the machine for possible hydraulic fluid leaks, damage or wear to hydraulic and mechanical components.

Maintenance

Minimum Recommended Maintenance Intervals

Maintenance Procedure Service	Maintenance Interval &			
† Check battery fluid level Check battery cable connections † Change engine oil Lube front wheel bearing Lube traction control linkage	25 hours	Every 100 hours	Every 400 hours	Every 800 hours
Replace engine oil filter Inspect remote air filter element Inspect the engine air filter element Lube the steering shaft grease fitting Check the steering chain adjustment † Torque the wheel lug nut				
† Change hydraulic oil Replace the hydraulic oil filter filter Replace the remote air filter element Replace the engine air filter element				
Replace spark plugs Replace fuel filter Decarbon the combustion chamber Adjust the valves and torque the head Check Engine RPM (idle and full throttle) Drain and clean the fuel tank				
† Initial break in at 8 hours				
Replace moving hoses Replace traction safety switch		Annual Recommendations: Items are recommended every 1500 hours or two years, whichever occurs first.		

Daily Maintenance (check):

Safety interlock operation
 Steering operation
 Engine oil level
 Air filter/precleaner condition
 Clean the engine cooling fins
 Unusual noises
 Hydraulic system level
 Hydraulic hoses
 Fluid leaks
 Fuel level

Tire pressure
 Instrument operation



CAUTION

Before servicing or making adjustments to the machine, stop the engine and remove the key from the switch.

LUBRICATION

The Sand Pro has (3) grease fittings that must be lubricated regularly with No. 2 general purpose, lithium-base grease. Lubricate the front wheel bearing and traction control linkage after every 25 hours of operation. Lubricate the steering shaft every 100 hours.

The bearings and bushings that must be lubricated are: front wheel bearing (Fig. 9), traction control linkage (Fig. 10) and steering shaft (Fig. 11).

1. Wipe the grease fitting clean so that foreign matter cannot be forced into the bearing or bushing.
2. Pump grease into the bearing or bushing.
3. Wipe up excess grease.



Figure 9

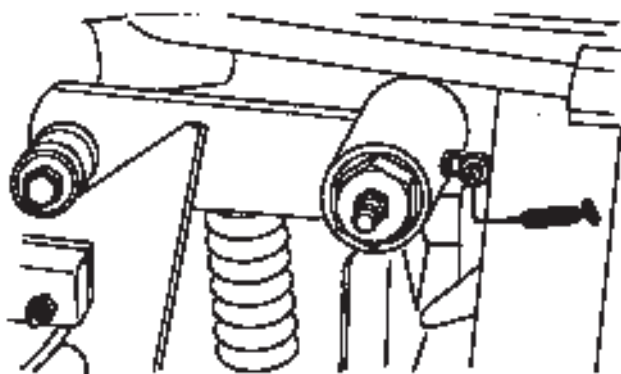

Figure 10

NOTE: We do not recommend lubricating the steering

chain unless it becomes stiff because of rust. If the chain rusts, it may be lubricated lightly with a DRY-TYPE lubricant.

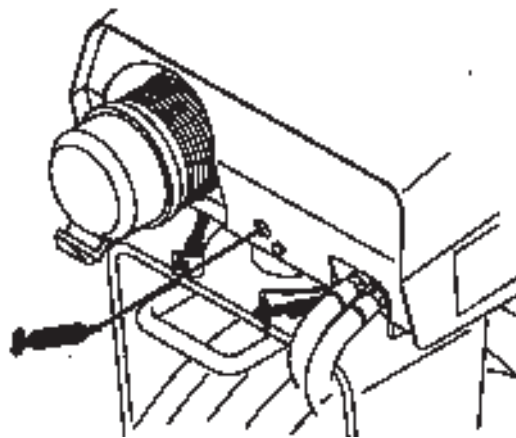

Figure 11

CHANGING ENGINE OIL AND FILTER

For new engines, change the oil after the first 8 operating hours. Thereafter, under normal conditions, change the oil after every 25 hours of engine operation.

1. Park the machine on a level surface and turn the engine off.
2. Remove the drain plug and let oil flow into the drain pan. When oil stops, install the drain plug.

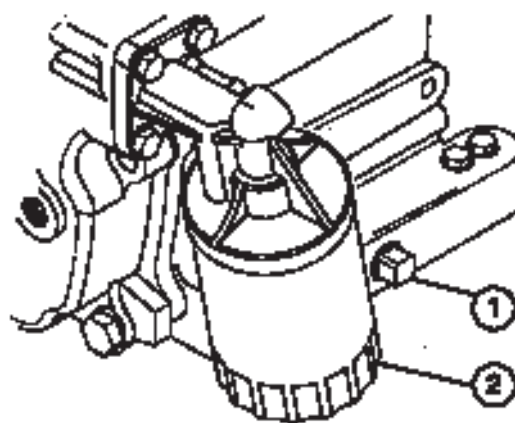

Figure 12

1. Drain plug
2. Oil filter

3. Remove the oil filter. Apply a light coat of clean oil to the new filter gasket.
4. Screw the filter on by hand until the gasket contacts

the filter adapter, then tighten 1/2 to 3/4 turn further. DO NOT OVER-TIGHTEN.

5. ADD OIL TO THE CRANKCASE.
6. Dispose of oil properly.

SERVICING THE AIR CLEANER

Inspect the paper element every 100 hours of operation and replace it every 400 hours or when dirty or damaged. Do not wash the paper element or do not clean it with compressed air as damage will result.

1. Park the machine on a level surface and turn the engine off.
2. Pivot the seat upward.
3. Remove the knobs and air cleaner cover.
4. Remove the filter and cover plate. Inspect the filter for cleanliness, ruptures, holes and tears. Replace a defective filter element.

Note: With the air cleaner disassembled, check the air cleaner components for damage. Replace them if necessary. Make sure the rubber breather tube in the base plate is securely in place or severe engine damage may occur. Also, make sure the carburetor breather hose is routed out through the engine vents.

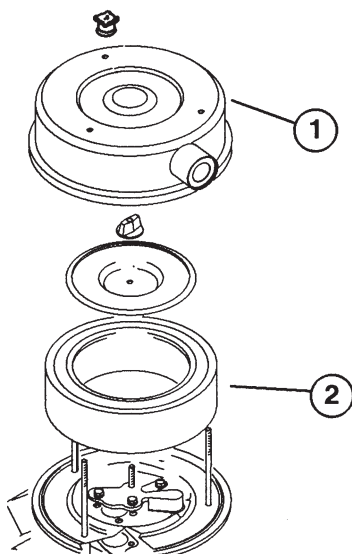

Figure 13

1. Air cleaner cover
2. Paper element

5. Reinstall the air cleaner and cover plate.
6. Reinstall the air cleaner cover and secure it with the knobs.

GENERAL AIR CLEANER MAINTENANCE

1. Check the air cleaner body for damage that could possibly cause an air leak. Replace a damaged air cleaner body.
2. Replace the air cleaner filter every 400 hours (more frequently in extremely dusty or dirty conditions). Do not over service the air filter.
3. Be sure the cover is sealing around the air cleaner body.

SERVICING THE REMOTE AIR CLEANER

1. Release the latches securing the air cleaner cover to the air cleaner body. Separate the cover from the body. Clean the inside of the air cleaner cover.

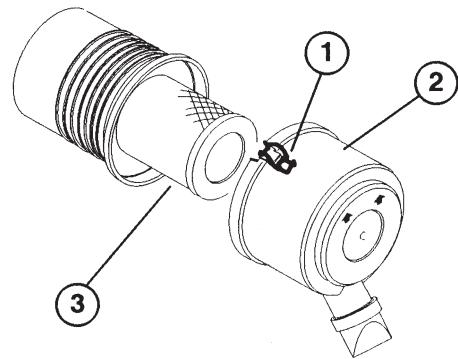

Figure 14

1. Air cleaner latches
2. Dust cup
3. Filler

Washing Method

- A. Prepare a solution of filter cleaner and water and soak the filter element about 15 minutes. Refer to directions of the filter cleaner carton for complete information.
- B. After soaking the filter for 15 minutes, rinse it with clear water.

- C. Dry the filter element using warm, flowing air (160°F max), or allow element to air-dry. Do not use compressed air or a light bulb to dry the filter element because damage could result.

Compressed Air Method

- A. Blow compressed air from inside to the outside of the dry filter element. Do not exceed 100 psi to prevent damage to the element.
- B. Keep the air hose nozzle at least one inch from the pleated paper, and move the nozzle up and down while rotating the filter element. Inspect for holes or tears by looking through the filter toward a bright light.
5. Inspect the new filter for shipping damage. check the sealing end of the filter. Do not install a damaged filter.
 6. Insert the new filter properly into the air cleaner body. Make sure the filter is sealed properly by applying pressure to the outer rim of the filter when installing. Do not press on the flexible center of the filter.
 7. Install the cover and secure the latches. Make sure the cover is positioned with TOP side up.

ADJUSTING THE THROTTLE CONTROL

Proper throttle operation is dependent upon proper adjustment of the throttle control. Before adjusting the carburetor, assure the throttle control is operating correctly.

1. Pivot the seat upward.
2. Loosen the cable clamp screw securing the cable to the engine.
3. Move the remote throttle control lever forward to the FAST position.
4. Pull firmly on the throttle cable until the back of the swivel contacts stop.
5. Tighten the cable clamp screw and check the engine RPM setting.

High Idle: 3150 ± 50

Low Idle: 1750 ± 50

ADJUSTING THE CHOKE CONTROL

1. Pivot the seat upward.
2. Loosen the cable clamp screw securing the cable to the engine.

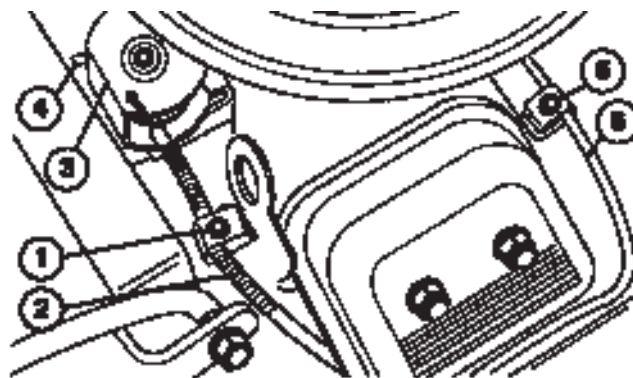

Figure 15

1. Throttle casing clamp screw
2. Throttle cable
3. Swivel
4. Stop
5. Choke casing clamp screw
6. Choke cable

3. Move the remote choke control lever forward to the CLOSED position.
4. Pull firmly on the choke cable until the choke butterfly is completely closed, then tighten the cable clamp screw.

SPARK PLUGS

Replace the spark plugs after every 100 operating hours or yearly, whichever occurs first. Recommended air gap is 0.030".

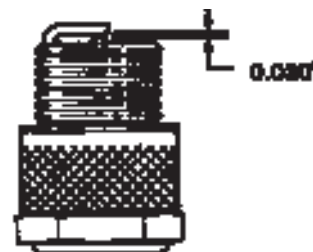

Figure 16

Correct spark plug to use is a Champion RC 12YC.

CLEANING THE CYLINDER HEAD FINS

To avoid overheating and possible engine damage, the cooling fins on the cylinder head must be kept clean.

CHANGING HYDRAULIC SYSTEM OIL AND FILTER

The hydraulic system filter must be changed initially, after the first 8 hours of operation, and thereafter every 400 hours of operation or yearly, whichever comes first. Use a genuine Toro oil filter for replacement. The hydraulic oil must be changed every 400 hours of operation or yearly, whichever comes first.

1. Park the machine on a level surface and turn the engine off.
2. Pivot seat upward.
3. Disconnect hose from bottom fitting of the reservoir and let oil flow into drain pan. Reinstall and tighten the hose when the oil stops draining.
4. Clean the area around the hydraulic oil filter. Remove the filter from the bottom of the filter housing and allow the oil to flow into a drain pan. Use a bottom-type filter wrench. Dispose of the oil filter properly.
5. Apply a film of oil on the filter gasket. Install the filter by hand until the gasket contacts mounting head; then tighten filter an additional three-fourth's turn.

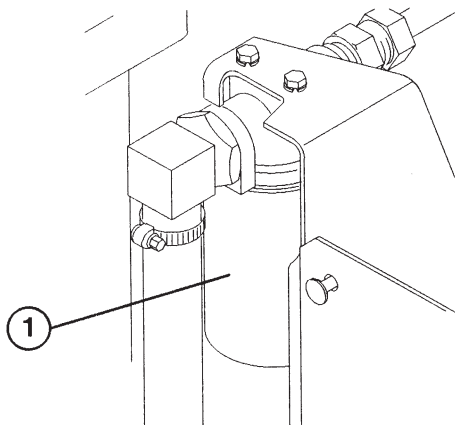

Figure 17

1. Hydraulic filter

6. Fill the reservoir to proper level, refer to *Check the Hydraulic System*.
7. Place all controls in the neutral or disengaged position and start the engine. Run the engine at its lowest possible RPM to purge the system of air.
8. Run the engine until the lift cylinder extends and retracts and forward and reverse wheel motion is achieved.
9. Stop the engine and check the oil level in the reservoir, add oil if necessary.
10. Check all connections for leaks.
11. Lower the seat.
12. Dispose of oil properly.

CHECKING HYDRAULIC LINES AND HOSES

Check hydraulic lines and hoses daily for leaks, kinked lines, loose mounting supports, wear, loose fittings, weather deterioration and chemical deterioration. Make all necessary repairs before operating.

WARNING

Keep body and hands away from pin hole leaks or nozzles that eject high-pressure hydraulic fluid. Use cardboard or paper to find hydraulic leaks. Hydraulic fluid escaping under pressure can penetrate skin and cause injury. Fluid accidentally injected into the skin must be surgically removed within a few hours by a doctor familiar with this form of injury or gangrene may result.

REPLACING THE FUEL FILTER

An in-line filter is incorporated into the fuel line. Use the following procedures should replacement become necessary:

1. Close the fuel shut-off valve (Fig. 8).
2. Clamp both fuel lines that connect to the fuel filter so gasoline cannot drain when lines are removed.
3. Loosen the hose clamps at both ends of the filter and pull the fuel lines off the filter.

- Slide hose clamps onto the ends of the fuel lines. Push the fuel lines onto the fuel filter and secure them with hose clamps. Be sure the arrow on side of filter points toward the carburetor.

BATTERY STORAGE

If the machine will be stored for more than 30 days, remove the battery and charge it fully. Either store it on the shelf on the machine. Leave the cables disconnected if stored on the machine. Store the battery in a cool atmosphere to avoid quick deterioration of the charge in the battery. To prevent the battery from freezing, make sure it is fully charged. The specific gravity of a fully charged battery is 1.250.

BATTERY CARE

- Battery electrolyte level must be properly maintained and the top of the battery kept clean. If the machine is stored in a location where temperatures are extremely high, the battery will run down more rapidly than if the machine is stored in a location where temperatures are cool.



CAUTION

Wear safety goggles and rubber gloves when working with electrolyte. Charge the battery in a well ventilated place so gases produced while charging can dissipate. Since the gases are explosive, keep open flames and electrical spark away from the battery; do not smoke. Nausea may result if the gases are inhaled. Unplug the charger from the electrical outlet before connecting to or disconnecting charger leads from battery posts.

- Keep the top of battery clean by washing periodically with a brush dipped in ammonia or bicarbonate of soda solution. Flush the top surface with water after cleaning. Do not remove the fill cap while cleaning.



WARNING

Connecting cables to the wrong post could result in personal injury and/or damage to the electrical system.

- Battery cables must be tight on terminals to provide good electrical contact.
- If corrosion occurs at the terminals, disconnect the cables, negative (-) cable first and scrape clamps and terminals separately. Reconnect cables, positive (+) cable first and coat terminals with petroleum jelly.
- Check the electrolyte level every 25 operating hours or, if the machine is in storage, every 30 days.
- Maintain cell level with distilled or demineralized water. Do not fill cells above the fill line.

IDENTIFICATION AND ORDERING

MODEL AND SERIAL NUMBERS

The SAND PRO has two identification numbers: a model number and a serial number. These numbers are stamped into a plate located on the left fender. In any correspondence concerning the unit, supply the model and serial numbers to ensure correct information and replacement parts are obtained.

Note: Do not order by reference number if a parts catalog is being used; use the part number.

To order replacement parts from an authorized TORO Distributor, supply the following information:

- Model and serial numbers.
- Part number, description, and quantity of parts desired.

The Toro Commercial Products Two-Year Limited Warranty

The Toro Company warrants your 1996 or newer Toro Commercial Product ("Product") purchased after January 1, 1997, to be free from defects in materials or workmanship for the period of time listed below. Where a warrantable condition exists, Toro will repair the Product at no cost to you including diagnosis, labor, parts, and transportation. This warranty begins on the date the Product is delivered to the original retail purchaser.

Warranty Duration: Two years or 1500 operational hours*, whichever occurs first.
***Product equipped with hour meter**

Owner Responsibilities:

As the Product owner, you are responsible for required maintenance and adjustments stated in your Owner's Manual. Failure to perform required maintenance and adjustments can be grounds for disallowing a warranty claim.

Instructions for Obtaining Warranty Service:

You are responsible for notifying the Commercial Products Distributor or Authorized Commercial Products Dealer from whom you purchased the Product as soon as you believe a warrantable condition exists.

If you need help locating a Commercial Products Distributor or Authorized Dealer, or if you have questions regarding your warranty rights or responsibilities, you may contact us at:

Toro Commercial Products Service Department
8111 Lyndale Avenue South
Minneapolis, MN, 55420-1196
Telephone: (612) 888-8801
Facsimile: (612) 887-8258
E-Mail: Commercial.Service@Toro.Com

Maintenance Parts:

Parts scheduled for replacement as required maintenance ("Maintenance Parts"), are warranted for the period of time up to the scheduled replacement time for that part.

Items/Conditions Not Covered:

Not all product failures or malfunctions that occur during the warranty period are defects in materials or workmanship. The items/conditions listed below are not covered by this warranty:

- Product failures which result from the use of non-Toro replacement parts, or from installation and use of add-on, modified, or unapproved accessories are not covered.
- Product failures which result from failure to perform required maintenance and/or adjustments are not covered.
- Product failures that result from operating the Product in an abusive, negligent or reckless manner are not

covered.

- This warranty does not apply to parts subject to consumption through use unless found to be defective. Examples of parts which are consumed, or used up, during normal Product operation include, but are not limited to, blades, reels, bedknives, tines, spark plugs, castor wheels, tires, filters, belts, etc.
- This warranty does not apply to failures caused by outside influence. Items considered to be outside influence include, but are not limited to, weather, storage practices, contamination, use of unapproved coolants, lubricants, additives, or chemicals, etc.
- This warranty does not apply to normal "wear and tear" items. Normal "Wear and Tear" includes, but is not limited to, damage to seats due to wear or abrasion, worn painted surfaces, scratched decals or windows, etc.

Other Legal Disclaimers:

The above remedy of product defects through repair by an authorized distributor or dealer is the purchaser's sole remedy for any defect. This warranty gives you specific legal rights, and you may also have other rights which vary from state to state.

Except for the Emissions warranty referenced below, if applicable, there is no other express warranty. All implied warranties of merchantability and fitness for use are limited to the duration of the express warranty.

Some states do not allow limitations on how long an implied warranty lasts, so the above limitation may not apply to you.

The Toro Company is not liable for indirect, incidental or consequential damages in connection with the use of the Product, including any cost or expense of providing substitute Product or service during periods of malfunction or non-use.

Some states do not allow the exclusion of incidental or consequential damages, so the above exclusion may not apply to you.