



MODEL NO. 09801—60001 & OVER

**OPERATOR'S  
MANUAL**

**HYDROJECT® 3000 AERATOR**



# Foreward

The Hydroject 3000 is a water aerification device that penetrates and breaks up the soil with high-velocity water jets. This machine operates with minimal disruption to the playing surface since there are no cores to remove after aerification. After a quick rinse or irrigation cycle, the putting surface is ready for play.

The machine was designed to use water and NOT CHEMICALS. Since so many varieties of chemicals are used in the Golf environment and since these chemicals react differently with Hydroject components, the Toro Company will not accept responsibility for equipment or environmental damage caused by using chemicals. Using chemicals in your equipment is done at your own risk!

The Hydroject 3000 releases a tremendous energy through the spray nozzles. **DO NOT OPERATE THIS UNIT ON CONCRETE OR ASPHALT BECAUSE IT WILL PENETRATE THESE SURFACES.**

Since this is a high-quality product, Toro is concerned about the future use of the machine and safety of the user. Therefore, read this manual to familiarize yourself with safety, operation and maintenance instructions. Certain information in this manual is emphasized. DANGER, WARNING and CAUTION identify personal safety-related information. IMPORTANT identifies mechanical information demanding special attention. Be sure to read this directive because it deals with the possibility of damaging a part or parts of the machine. NOTE identifies general information worthy of special attention.

## Service Manual

A service manual is available for the Hydroject 3000 Aerator. This publication provides information for trouble shooting, testing, adjusting and repairing the machine. To order this publication, contact your local authorized Toro Distributor. Ask for Form 91-764-SL, Hydroject 3000 service manual.

## Table of Contents

SAFETY INSTRUCTIONS	3-4	Inspection and Cleanup After Use	16
SAFETY INSTRUCTIONS & DECALS	.5	Pushing or Towing The machine	16
SPECIFICATIONS	6-7	TROUBLE SHOOTING	18-20
FLUID RECOMMENDATIONS	8	MAINTENANCE	17
IDENTIFICATION AND ORDERING	8	Servicing The pre- Filter	21
BEFORE OPERATING	10-12	Replacing Main Water Filter	21
Activate and Charge The battery	10	Changing Engine Oil and Filter	22
Check Engine Oil	10	Servicing The Air Cleaner	22
Fill The fuel Tank With Gasoline	11	Checking and Replacing The Spark Plug	24
Check Gear Case Fluid Level	11	Cleaning Cylinder Head Fins	24
Check Pump Case Fluid Level	12	Changing Gear Case Oil and Filter	25
Check Tire Pressure	12	Changing Pump Case Oil	25
Check Accumulator Charge	12	Checking Hydraulic Lines and Hoses	25
CONTROLS	13	Adjusting Roller Spray	27
OPERATING INSTRUCTIONS	14-16	Servicing Spray Wash Nozzles or Strainers	28
Operating Precautions	14	Battery Care	28
Starting/Stopping The engine	14	SEASONAL STORAGE	29
Training Period	14	SERVICE INTERVAL CHART	30
Operating Procedure	14		
Check Interlock System	16		
Transport Operation	16		

# Safety Instructions

Hazard control and accident prevention are dependent upon the awareness, concern, and proper training of the personnel involved in the operation, transport, maintenance, and storage of the machine. Improper use or maintenance of the machine can result in injury or death. To reduce the potential for injury or death, comply with the following safety instructions.

**WARNING:** Engine exhaust contains carbon monoxide which is an odorless, deadly poison. Carbon monoxide is also known to the State of California to cause birth defects. Do not run the engine indoors or in an enclosed area.

## BEFORE OPERATING

1. Read and understand the contents of this Operator's Manual before operating the machine. Become familiar with all controls and know how to stop quickly.
2. Never allow children to operate the machine. Do not allow adults to operate the machine without proper instruction. Only trained operators who have read this manual should operate this machine.
3. Never operate the machine when under the influence of drugs or alcohol.
4. Before attempting to start the engine, engage the parking brake.
5. Remove all debris or other objects that might interfere with operation. Keep all bystanders away from the work area.
6. Keep all shields and safety devices in place. If a shield, safety device or decal is defective or damaged, repair or replace it before resuming operation. Also tighten any loose nuts, bolts and screws to assure the machine is in safe operating condition.
7. Do not operate the machine while wearing sandals, tennis shoes, sneakers or shorts. Also, do not wear loose fitting clothing which could get caught in moving parts. Always wear long pants and substan-

tial shoes. Wearing safety glasses, safety shoes, ear protection and a helmet is advisable and required by some local ordinances and insurance regulations.

8. Fill the fuel tank with gasoline before starting the engine. Avoid spilling gasoline. Since gasoline is flammable, handle it carefully.
  - A. Use an approved gasoline container.
  - B. Do not fill the tank while the engine is hot or running.
  - C. Do not smoke while handling gasoline.
  - D. Fill the fuel tank outdoors and up to about 25 mm from top of the tank, not the filler neck.
  - E. Wipe up any spilled gasoline.
9. Check the interlock switches daily for proper operation. If a switch fails, replace it before operating the machine. The interlock system is for your protection, so do not bypass it. Replace all interlock switches every two years.

## WHILE OPERATING

10. **DON'T TAKE AN INJURY RISK!** When a person or pet appears unexpectedly in or near the WORKING area, STOP AERATING.
11. Keep your hands and feet away from nozzle and roller area. High-velocity water jets can penetrate hands and feet. Penetration by the high-velocity water jets can cause serious personal injury. If accidental penetration occurs, seek medical attention immediately.
12. Never use chemicals in the water supply system.
13. Do not operate the water injection system on concrete or asphalt because the water jets will permanently damage these surfaces.

14. Start the engine with the parking brake engaged.
15. Do not run the engine in a confined area without adequate ventilation. Exhaust fumes are hazardous and could possibly be deadly.
16. Using the machine demands attention, and to prevent loss of control:
  - A. Use only in daylight or when there is good artificial light.
  - B. Watch for holes or other hidden hazards.
  - C. Do not transport the machine close to a sand trap, ditch, creek or other hazard.
17. If the machine starts to vibrate abnormally, shut off the engine. Remove the wires from the spark plugs to prevent the possibility of accidental starting. Check the machine for damage and defective parts. Repair any damage before restarting the engine and operating the machine.
18. Do not touch the engine or muffler while the engine is running or soon after it is stopped. These areas could be hot enough to cause a burn.
19. Before leaving the operator's position behind the handle engage the parking brake.
20. When leaving the machine unattended, engage the parking brake, shut OFF the engine and remove the key from the ignition switch.
24. Be sure the machine is in safe operating condition by keeping nuts, bolts and screws tight. Check all bolts and nuts frequently to be sure they are tightened to specification.
25. If the engine must be running to perform a maintenance adjustment, keep your hands, feet, clothing and other parts of your body away from any moving parts.
26. Make sure all hydraulic line connectors are tight, and all hydraulic hoses and lines are in good condition before applying pressure to the system.
27. Keep your body and hands away from pin hole leaks or nozzles that eject water or hydraulic fluid under high pressure. Use paper or cardboard, not your hands, to search for leaks. Hydraulic fluid or water escaping under pressure can have sufficient force to penetrate your skin and do serious damage. If either of these fluids are ejected into your skin they must be surgically removed within a few hours by a doctor familiar with this form of injury or gangrene may result.
28. Before disconnecting or performing any work on the hydraulic oil system, all pressure in the system must be relieved by stopping the engine and opening the by-pass valve.
29. Make sure all water line connectors are tight, and all hoses and lines are in good condition before applying pressure to the system.

## MAINTENANCE

21. Disconnect the wires from the spark plugs to prevent accidental starting of the engine when servicing, adjusting or storing the machine.
22. If the machine must be tipped to perform maintenance or an adjustment, close the fuel shut-off valve, drain gasoline from the fuel tank, oil from the crankcase and remove the battery.
23. To reduce potential fire hazard, keep the engine free of excessive grease, grass, leaves and accumulations of dirt.
30. Before disconnecting or performing any work on the water system, all pressure in the system must be relieved by stopping the engine and opening the bleed valve. Opening the bleed valve allows any trapped water to escape from the system and also allows the accumulator piston to move to the bottom of the accumulator cylinder.
31. The accumulator in this machine contains high-pressure dry nitrogen. Accumulator servicing requires special tools and precautions. Accumulators do not contain user-serviceable components. Improper accumulator servicing can cause dismemberment or death. Do not attempt to disassemble a accumulator; have this work done by a

Authorized Toro Distributor.

- 32.** Do not overspeed the engine by changing the governor settings. To be sure of safety and accuracy, have an Authorized TORO Distributor check maximum engine speed with a tachometer.
- 33.** The engine must be shut off before checking oil or adding oil to the crankcase.
- 34.** Allow the engine to cool before storing the machine in any enclosure such as a garage or storage shed. Make sure the fuel tank is empty if the machine is to be stored longer than 30 days. Do not store the machine near any open flame or where gasoline fumes may be ignited by a spark. Always store gasoline in a safety-approved, red metal container.
- 35.** When storing or transporting the machine (trailer), make sure the fuel shut-off valve is closed.
- 36.** Perform only those maintenance instructions described in this manual. If major repairs are ever needed or assistance is desired, contact an Authorized Toro Distributor. To ensure optimum performance and safety, always purchase genuine TORO replacement parts and accessories to keep the Toro all TORO. NEVER USE "WILL-FIT" REPLACEMENT PARTS AND ACCESSORIES MADE BY OTHER MANUFACTURERS. Look for the TORO logo to assure genuineness. Using unapproved replacement parts and accessories could void the warranty of The Toro Company.

# Symbol Glossary



SAFETY ALERT SYMBOL      GENERAL HAZARD SAFETY ALERT      CRUSHING OF WHOLE BODY, APPLIED FROM ABOVE      CRUSHING OF FINGERS OR HAND, FORCE APPLIED FROM SIDE      CUTTING OF FINGERS OR HAND      CUTTING OF FOOT      CRUSHING OR PUNCTURE OF FOOT, CORING HEAD

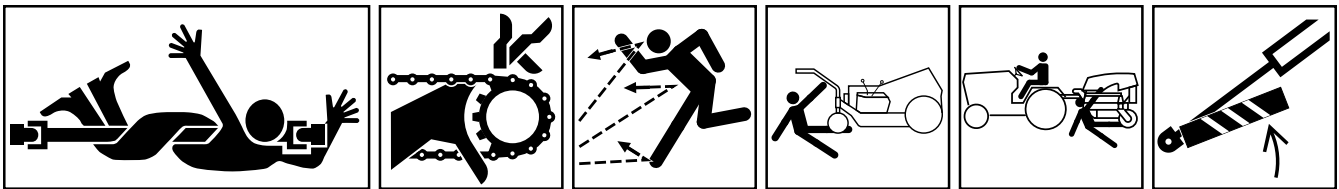

WHOLE BODY ENTANGLEMENT, IMPLEMENT INPUT DRIVE LINE      FINGERS OR HAND ENTANGLEMENT, CHAIN DRIVE      THROWN OR FLYING OBJECTS, WHOLE BODY EXPOSURE      RUNOVER/BACKOVER, GREENS AERATOR      RUNOVER/BACKOVER, HC 4000 AERATOR      SECURE LIFTING CYLINDER WITH LOCKING DEVICE BEFORE GETTING IN HAZARDOUS AREA

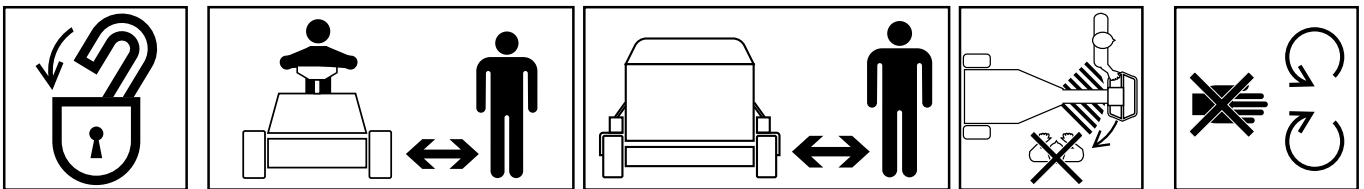

INSERT SAFETY LOCK BEFORE GETTING IN HAZARDOUS AREA      STAY A SAFE DISTANCE FROM MACHINE, GREENS AERATOR      STAY A SAFE DISTANCE FROM MACHINE, HC 4000 AERATOR      STAY CLEAR OF ARTICULATION AREA WHILE ENFINE IS RUNNING, GREENS AERATOR      DO NOT OPEN OR REMOVE SAFETY SHIELDS WHILE ENGINE IS RUNNING

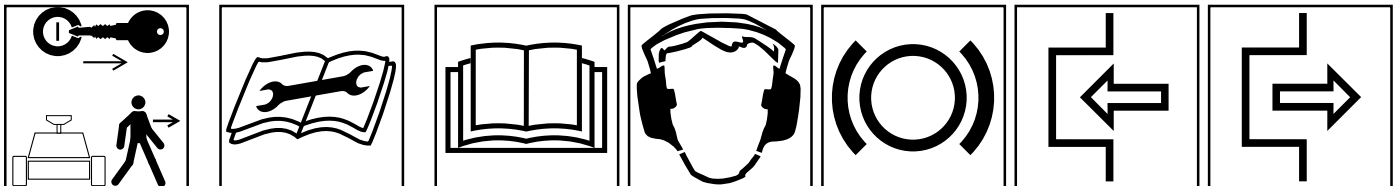

SHUT OFF ENGINE & REMOVE KEY BEFORE LEAVING OPERATOR POSITION, GREENS AERATOR      CONSULT TECHNICAL MANUAL FOR PROPER SERVICE PROCEDURES      READ OPERATOR'S MANUAL      HEARING PROTECTION MUST BE WORN      BRAKE SYSTEM      ENGAGE      DISENGAGE

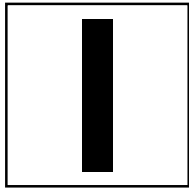

ON/START

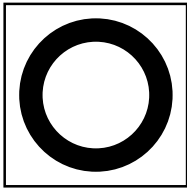

OFF/STOP



FAST

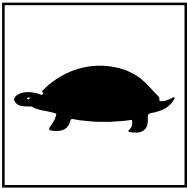

SLOW

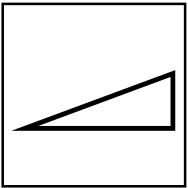

CONTINUOUS  
VARIABLE,  
LINEAR

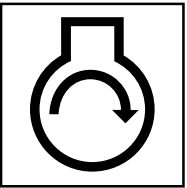

ENGINE START



ENGINE STOP

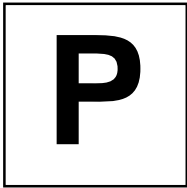

PARK



UNLEADED FUEL

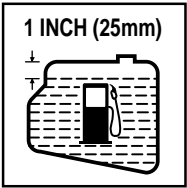

FUEL TANK FILL  
LINE



LOCK



UNLOCK

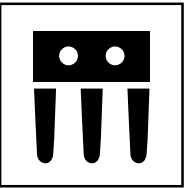

CORING HEAD

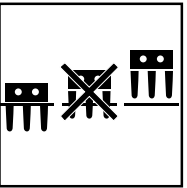

ALWAYS HAVE CORING HEAD  
FULLY UP FOR TRANSPORT &  
FULLY DOWN FOR CORING



TRACTION DRIVE

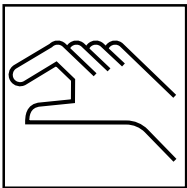

MANUAL

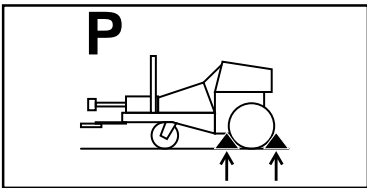

CHOCK WHEELS IN PARKED POSITION,  
ALWAYS PARK ON LEVEL SURFACE,  
FAIRWAY AERATOR

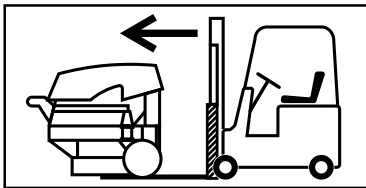

ALWAYS FORK FROM FRONT OR REAR  
OF MACHINE, HC 4000 AERATOR

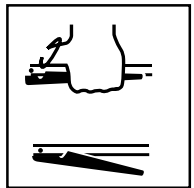

LEVER OPERATION

# Specifications

**Engine:** Onan, 4-cycle, opposed-twin, air-cooled, 17.9 kW (24 hp) @ 3600 rpm, 983 cc displacement. Electric start. Heavy-duty valve package. Extended service air cleaner. 2.8 l oil capacity. Solid-state ignition.

**Clutches:** Electromagnetic, dual-groove belt drive for the water pump and driveshaft flange brake/clutch for the main valve gearbox.

**Electrical:** 12-volt system with 20-amp circuit breaker protection. Relays for all high-current switching. Electronic controller and sensors for automatic start-up and shut-down sequence of the water injection system. Group 28 battery with 525 cold-crank amps.

**Traction Drive:** Closed-loop hydrostatic drive consisting of Sundstrand variable volume pump and Parker low-speed, high-torque wheel motor mounted to steering fork. Hydraulic system contains 4.73 l with 25-micron suction line filter and gearbox reservoir.

**Tires/Wheels:** Three, smooth-tread 2-ply, 18 x 9.50-8, pneumatic tubeless, tires. Demountable drop-center steel wheels with (4) lug nuts mounted to tapered roller bearing hubs on the transport arms and brake hub on the wheel motor. All are interchangeable.

**Brake:** Drum- and shoe-type parking brake mounted to the wheel motor. Holds unit on a 30% grade.

**Transport Lift:** 12-volt Warner Electric linear screw actuator with 15.24 cm stroke. Raises and lowers lift arm/transport tires and activates hole spacing control.

**Fuel Capacity:** 39.75 l gasoline.

## **Water Injection System:**

**Pre Filter**—Spin-down type with washable cartridge in clear plastic housing and plastic ball valve for flushing.

**Supply Filter**—Replaceable cartridge in plastic

housing with an air bleed button.

**Water Pressure Switch**—Senses for water pressure after the filter and turns on when pressure is over 138–193 kPa and turns off when pressure drops below 48–90 kPa.

**Pump**—Pump is a Toro exclusive design (patent pending) with cast stainless steel head and 3 piston plungers. Vee packing seals and Kevlar guides. Forged crankshaft with plasma sprayed ceramic on stainless steel plungers and cast iron connecting rods. Nominal performance is 4 rpm @ 34,473 kPa with 1400 rpm input.

**Accumulator**—Toro exclusive design with low charge pressure sensor, nitrogen gas charged to a maximum of 17,237 kPa.

**Cam and Gearbox**—Reduction gear drive for cam that actuates the main water valve. Roller cam follower rides on a cam specifically designed (patent pending) to control water injection at 5.3 cycles per second (320 rpm) and store energy in the accumulator between injections. Cast iron case also serves as 3.8 l hydraulic reservoir.

**Valve**—Cast stainless steel valve body functions as a mounting base for the accumulator, gearbox and manifold outlet. All high-pressure water flows in and out through the valve body. Pressure-balanced valve spool with floating (patent pending), hardened stainless seat aligns during assembly. Bleed valve in base allows for bleed-off of high pressure and drain down for cold weather storage. Bolted flanges and polyurethane O-rings mate all components to valve body.

**Rollers**—Pivoting aluminum rollers uniformly smooth the turf and provide protection from the nozzle discharge. Adjustable flow (0–3 gpm) spray wash system with 6 flood tip nozzles maintain clean rollers.

**Pressure Relief Valve**—Circle Seal Controls poppet-type valve preset to 34,473 kPa with corrosion resistant stainless and brass materials.

**Manifold and Nozzles**—Extruded stainless steel manifold with 11 flanged nozzle extensions containing check valves and hardened stainless discharge orifice. Check valves may be reversed in housing to block unused nozzles.

**Controls:**

**Engine Panel**—Throttle, choke, spray wash control, hour meter, water pressure gauge, spacing control lever, key switch and circuit breaker reset button.

**Steering Tiller Panel**— Traction bail, water system engage and disengage buttons, transport / aerate lift toggle switch and parking brake with buzzer alarm.

**Electronic Control Module**—Solid state potted device for sequencing start and stop of the water system. Interlocks for water pressure, transport lift and traction neutral.

**Ground Speed:**

Aerating: 0–3.2 kmh (both directions)  
 Transport: 0–6.4 kmh (both directions)

**Dimensions:**

Length—244.4 cm  
 Wheelbase—135.1 cm  
 Width—160 cm  
 Height—119.9 cm  
 Weight—429.2 kg

**Aeration Width:** 83.8 cm with 11 nozzles on 7.6 cm centers.

**Aeration Depth:** 10.2–15.2 cm depending on turf conditions and nozzle configuration.

**Hole Pattern:** Variable from 3.8–15.2 cm spacing in the direction of travel, and 7.6–15.2 cm increments in width.

**Depths and Nozzle Configurations:** All nozzles are identified with numbers indicating the drill size of the orifice. The standard configuration is 11 nozzles producing depths of 10.2–15.2 cm depending on turf conditions. Blocked nozzle locations are obtained by reversing the nozzle check valve ball and spring. See nozzle size chart and illustrations below:

**IMPORTANT: Use only nozzle configurations shown or damage to the machine may occur.**

Aluminum Washer, Toro Part no. 80-6680 is required with any nozzle change

Aluminum Washer, Toro Part no. 80-6680 is required with any nozzle change

**NOZZLE SIZE AND APPROXIMATE DEPTH CHART**

Part No.	Drill Size	Metric Size (mm)	Quantity of Nozzles		Depth
			Open	Blocked	
86-8130	#56	1.181	*	*	*
86-8131	#53	1.511	11	0	10.2–15.2 cm
86-8133	#46	2.057	6	5	15.2–20.3 cm

\*\*Additional nozzles may be blocked to compensate for pump wear.

## OPTIONAL STAGGERED SIZE NOZZLE CONFIGURATION

Part No.	Drill Size	Metric Size (mm)	Quantity of Nozzles		Depth
			Open	Blocked	
86-8130	#56	1.181	6 and	0**	7.6–10.1 cm
86-8133	#46	2.057	5	0**	15.2–20.3 cm

Aluminum Washer, Toro Part no. 80-6680 is required with any nozzle change

\*\*Additional nozzles may be blocked to compensate for pump wear.

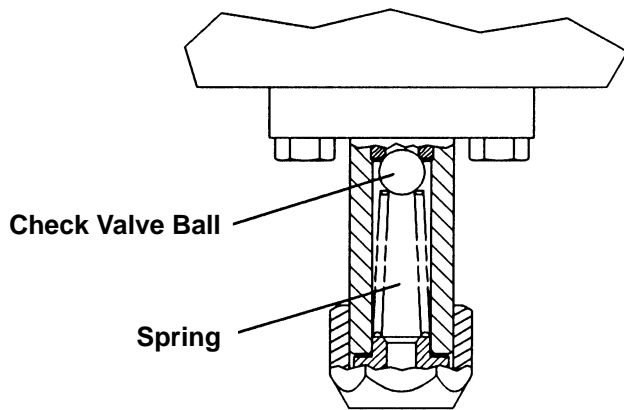

**OPEN NOZZLE**

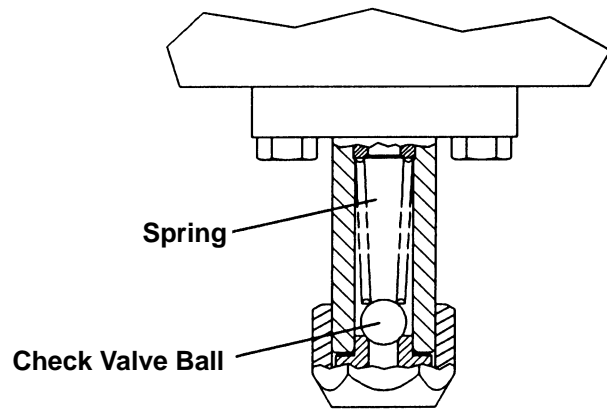

**CLOSED (BLOCKED) NOZZLE**

# Fluid Specifications

**Fuel**—Unleaded regular gasoline recommended to minimize engine intake valve and combustion chamber deposits.

**Engine Oil**—Service classification API SF, SG, SF/CC or SG/CC in a 30 weight viscosity grade.

**Engine Oil Filter**—Toro part no. 57-8530

**Hydraulic Oil**—Mobil DTE 26 or other interchangeable equivalent. See chart below for equivalent oils.

Mobil	DTE 26
Shell	Tellus 68
Amoco	Rykon Oil #68
Conoco	Super Hydraulic Oil 68
Exxon	Nuto H 68
Kendall	Kenoil R&O 68
Pennzoil	Penreco 68
Phillips	Magnus A 68
Standard	Energol HLP 68
Sun	Sunvis 831 WR
Union	Unax AW 68

**Hydraulic Oil Filter**—Toro part no. 67-8110

**Water Pump Case Oil**—Mobil DTE Extra Heavy or other interchangeable ISO Grade 150 PE-700-A (Heavy Inhibited Hydraulic & General Purpose) See following chart for equivalent oils.

Mobil	DTE EH (Extra Heavy)
Shell	Turbo 150
Amoco	American Ind. Oil 150
Chevron	AW Machine Oil 150
Conoco	Dectol R & O150
Exxon	Terresstic 150
Kendall	Ken-Tran 080
Pennzoil	Penreco 150/AW150
Phillips	Magnus Oil 150
Standard	Energol HLP 150
Sun	Sunvis 150
Union	Unax RX 150/Turbine Oil 150
Valvoline	ETC (R&O) #70

**Water Supply**—Recommend a source with 26.5–30.2 l per minute. A minimum pressure of 207 kPa at the machine is required for the pump to engage. Maximum allowable pressure of 1,379 kPa. Although irrigation water pumped from ponds or effluent holding pools can be used, not all conditions can be handled by the machine's filtration system. Additional or alternative filtration may be required.

**Water Filter Cartridge**—Toro part no. 86-8630

**DO NOT USE CHEMICALS**—Concern for environmental issues and corrosive affects on machine components.

# Identification and Ordering

## MODEL AND SERIAL NUMBERS

The HYDROJECT 3000 has two identification numbers: a model number and a serial number. The two numbers are stamped on a plate which is riveted to the frame. In any correspondence concerning the HYDROJECT 3000, supply model and serial numbers to be sure that correct information and replacement parts are obtained.

To order replacement parts from an authorized TORO Distributor, supply the following information:

1. Model and serial numbers of the machine.

2. Part number, description and quantity of parts desired.

**Note:** Do not order by reference number if a parts catalog is being used; use the part number.

# Before Operating

## ACTIVATE AND CHARGE THE BATTERY

1. Since the battery is not filled with electrolyte or activated, bulk electrolyte with 1.260 specific gravity must be purchased from a local battery supply outlet.



### WARNING

Electrolyte gases are explosive and can cause serious injury to eyes, lungs and skin. Wear safety goggles and rubber gloves when working with electrolyte or the battery. Charge the battery in a well-ventilated place so gasses produced while charging can dissipate. Since the gasses are explosive, keep open flames and electrical sparks away from the battery; do not smoke. Nausea may result if the gasses are inhaled. Unplug the charger from the electrical outlet before connecting or disconnecting the charger's leads.

2. Release the hood latches and raise the hood.
3. Loosen the capscrew securing the battery clamp to the machine and remove the battery. Remove the filler caps from the battery and slowly fill each cell until electrolyte is just above the plates.
4. Replace the filler caps and connect a 3- to 4-amp battery charger to the battery posts. Charge the battery at a rate of 3 to 4 amperes for 4 to 8 hours.
5. When the battery is charged, disconnect the charger from electrical outlet and battery posts.
6. Remove the filler caps. Slowly add electrolyte to each cell until the level is up to fill ring. Install the filler caps.

**IMPORTANT: Do not overfill the battery. Electrolyte will overflow onto other parts of the machine and severe corrosion and deterioration will result.**

7. Install the battery and secure it with the battery clamp.
8. Install the positive cable (rubber boot over end) to the positive (+) terminal and the negative cable (black) to the nega-

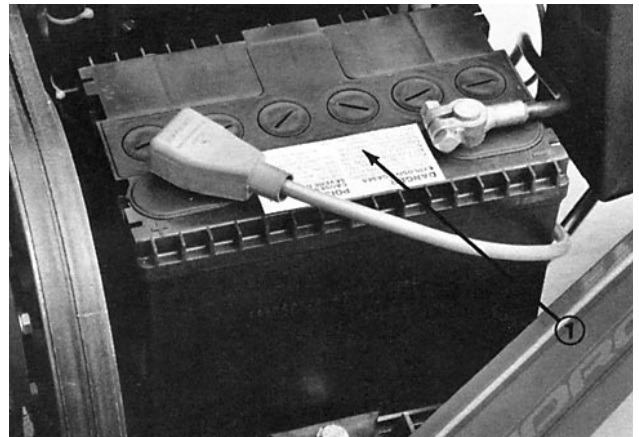

Figure 1

1. Battery

tive (-) terminal of the battery and secure with capscrews and nuts. Slide the rubber boot over the positive terminal to prevent possible short-out (Fig. 2).

9. Lower the hood and secure the latches.

## CHECK THE ENGINE OIL

The Onan engine is shipped with 3 quarts of oil in the crankcase; however, the oil level must be checked before and after the engine is first started.

1. Position the machine on a level surface.
2. Unscrew the dipstick and wipe it with a clean cloth. Screw the dipstick into the filler neck and make sure it is seated fully. Unscrew the dipstick out of the filler neck and check the level of oil. If the oil level is low, add enough to raise the level to the FULL mark on the dipstick.

**Note:** If the level of oil is at the ADD mark on the dipstick, add 1 quart of oil to raise the oil level to FULL. Do not overfill

3. Pour oil into the filler neck until the level is at the FULL mark on the dipstick. The Onan engine uses any high-quality oil having the American Petroleum Institute— API— “service classification” SF or SG. Recommended viscosity (weight) of oil is SAE 30.

**IMPORTANT: The Hydroject 3000 operates at very high engine loads, so check the level of oil every 8 operating hours or daily. A new engine may consume some oil until broken in. Initially, change the oil after the first 25 hours of operation; thereafter, under normal conditions, change the oil and filter after every 100 hours of operation. However, change oil more frequently when the engine is operated in extremely dusty or dirty conditions.**

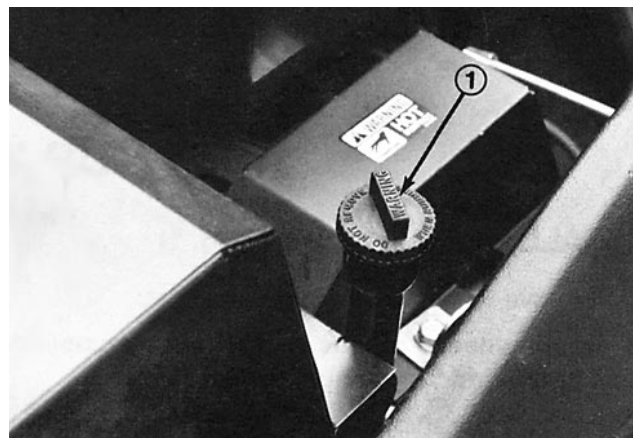

Figure 2

1. Dipstick

## FILL THE FUEL TANK WITH GASOLINE

THE TORO COMPANY STRONGLY RECOMMENDS THE USE OF FRESH CLEAN, UNLEADED REGULAR GRADE GASOLINE IN TORO GASOLINE POWERED PRODUCTS. UNLEADED GASOLINE BURNS CLEANER, EXTENDS ENGINE LIFE, AND PROMOTES GOOD STARTING BY

## REDUCING THE BUILD-UP OF COMBUSTION CHAMBER DEPOSITS.



### DANGER

Because fuel is flammable, caution must be used when storing or handling it. Do not fill the fuel tank while the engine is running, hot or when the machine is in an enclosed area. Vapors may build up and be ignited by a spark or flame source many feet away. **DO NOT SMOKE** while filling the fuel tank to prevent the possibility of an explosion. Always fill the fuel tank outside and wipe up any spilled fuel before starting the engine. Use a funnel or spout to prevent spilling, and fill the tank no higher than 2.5 cm (one inch) below top of the tank, (bottom of the filler neck). **DO NOT OVER FILL.**

Store fuel in a clean safety approved container and keep the cap on the container. Keep fuel in a cool, well-ventilated place; never in an enclosed area such as a hot storage shed. To assure volatility, do not buy more than a 30-day supply of gasoline, or a 6-month supply of diesel fuel.

Since many children like the smell of gasoline, keep it out of their reach because the fumes are explosive and dangerous to inhale.

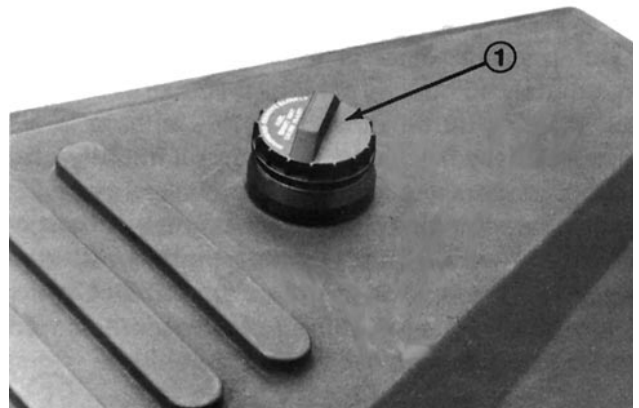

**Figure 3**

1. Fuel tank cap

**Note:** Do not mix oil with gasoline. Never use methanol, gasoline containing methanol, gasohol, gasoline additives, premium gasoline, or white gas because the engine/fuel system damage could result.

1. Remove the cap from the fuel tank and fill the 37.85 l tank to about 2.5 cm from the top of the tank, bottom of the filler neck with unleaded gasoline. Install the fuel tank cap tightly.
2. Wipe up gasoline that may have spilled to prevent a fire hazard.

## CHECK GEAR CASE FLUID LEVEL

The gear case, which acts as the reservoir for the hydraulic system, is filled at the factory with approximately 3.8–4.7 l of

Mobil DTE 26 hydraulic oil. Check the level of hydraulic oil on the sight gauge before the engine is first started and daily thereafter. Change the filter initially after 25 hours of operation, thereafter change the oil and filter every 250 hours of operation. The oil and filter must be changed immediately when any contamination, sludge, water or condensation appears in the oil or on sight gauge. Determine and correct oil contamination problem before restarting the engine and operating the machine.

1. Position the machine on a level surface.
2. Release the hood latches and raise the hood.
3. Check the level of hydraulic oil on the sight gauge. Fluid level should be up to the middle of gauge window.
4. If the fluid level is low, remove the filler cap and add enough Mobil DTE 26 hydraulic oil or equivalent oil (refer to fluid recommendation table) to bring oil up to the proper level.
5. Lower the hood and secure the latches.

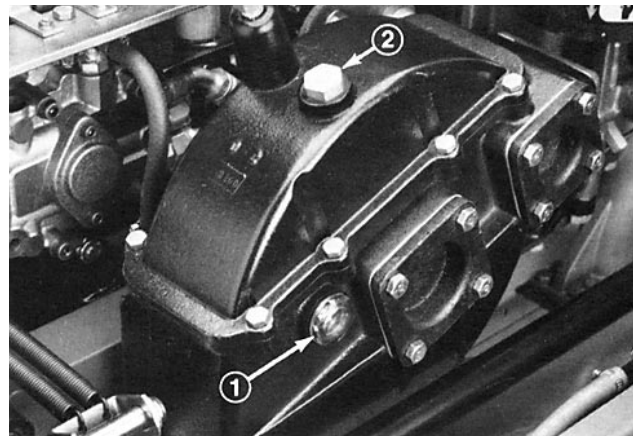

Figure 4

1. sight gauge
2. Filler cap

## CHECK PUMP CASE FLUID LEVEL

The pump crank case is filled at the factory with 1.8 cl of Mobil DTE Extra Heavy oil. Check the level of oil on the dipstick before the engine is first started and daily thereafter. Change the oil initially after 25 hours of operation, thereafter change every 250 hours of operation. The oil must be changed immediately when any contamination, sludge, water or condensation appears in oil. Determine and correct oil contamination problem before restarting the engine and operating the machine.

1. Position the machine on a level surface.
2. Release the hood latches and raise the hood.
3. Remove the dipstick/filler cap and check the level of oil on the dipstick. The fluid level should be up to the FULL mark.
4. If the fluid level is low, add enough Mobil DTE Extra Heavy oil or equivalent oil (refer to fluid recommendation table) to bring the oil up to proper level. **DO NOT OVER-FILL.**
5. Lower the hood and secure the latches.

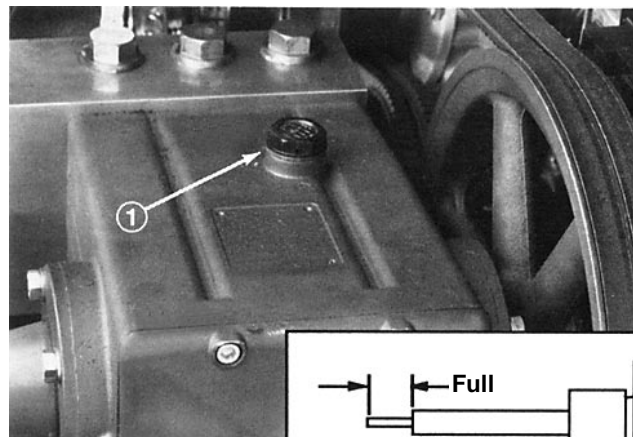

Figure 5

1. Dipstick/Filler cap

## CHECK TIRE PRESSURE

Tires are over inflated for shipping. Make sure the front and rear tires are inflated to 55–82 psi.

## CHECK THE ACCUMULATOR CHARGE

Have the accumulator charge checked before and after each operating season by an Authorized TORO Distributor.



### WARNING

Charged accumulators contain high-pressure nitrogen. Nitrogen is the only gas to use for accumulator charging. Installing Improper gasses in an accumulator can cause an explosion and death.

Charging requires special tools and precautions. Charge accumulators in a well-ventilated area. Have the accumulator checked and charged by an authorized TORO distributor.

Wear eye protection. Keep your hands and face away from the gas valve.

Slowly open the high-pressure water bleed valve before servicing any component connected to the high-pressure water system. Opening the high-pressure bleed valve allows any trapped water to escape from the system and also allows the accumulator platon to move the bottom of the accumulator cylinder. Failure to open the bleed valve before servicing high-pressure water components can cause personal injury, dismemberment or death!

Charged accumulators cannot be shipped via air freight.

# Controls

**Ignition Switch** (Fig. 6)—The ignition switch, which is used to start and stop the engine, has three positions: OFF, ON and START.

**Choke** (Fig. 6)—To start the engine, close the carburetor choke by pulling the choke control outward to the FULL position. After the engine starts, regulate the choke to keep the engine running smoothly. As soon as possible, open the choke by pushing it inward to the OFF position.

**Throttle** (Fig. 6)—The throttle is used to regulate engine speed. Moving the throttle forward increases engine speed—FAST; rearward decreases engine speed—SLOW.

**Spray Wash Control** (Fig. 6)—Pull the handle upward to activate the roller spray wash system. Move the control knob up or down to adjust spray rate to keep rollers free of debris.

**Hour Meter** (Fig. 6)—The hour meter registers accumulated hours of engine operation. Use the hour meter to determine intervals for service maintenance and lubrication.

**Water Pressure Gauge** (Fig. 6)—Registers supply water pressure in the system. Also acts as a interlock switch preventing the water pump from starting if water pressure is below 138–193 kPa or stopping the water pump if the water pressure drops below 48–89.6 kPa. Check the gauge frequently to monitor the water pressure.

**Circuit Breaker Reset Button** (Fig. 6)—a push button to reset breaker, after correcting malfunctions in the electrical system. The button also serves as a switch to interrupt power to the relays.

**Spacing Control Lever** (Fig. 6)—Moving the control away from handle increases the aerating ground speed and distance between holes. Moving the control toward the handle decreases aerating ground speed and distance between holes. The setting will be overridden when the machine is shifted to the transport position.

**Traction Bail** (Fig. 7)—Engages and regulates fore and aft traction operation of the machine. Releasing the bail stops traction operation and will also stop water injection in 3 to 4 seconds, unless the bail is engaged. Transport speed is regulated by the distance the bail is moved.

**Transport/Aerate Toggle Switch** (Fig. 7)—Lowers the machine

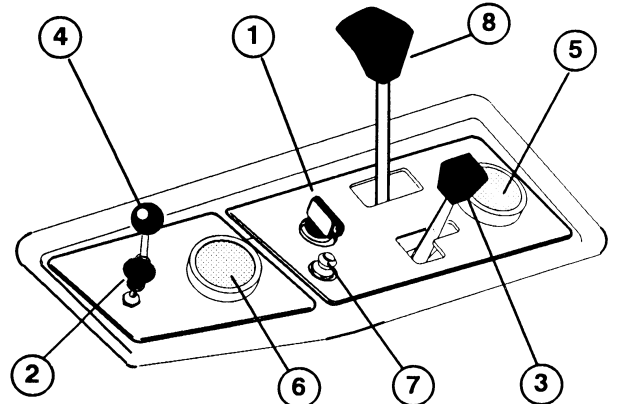

Figure 6

1. Ignition switch
2. Choke
3. Throttle
4. Spray wash control
5. Hour meter
6. Water pressure gauge
7. Circuit breaker reset button
8. Spacing control lever

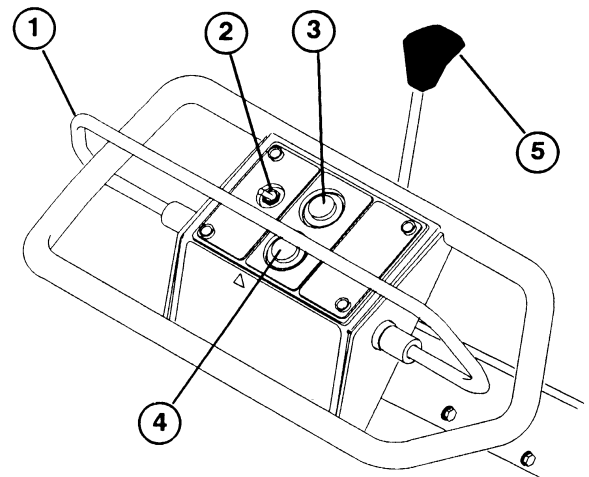

Figure 7

1. Traction Bail
2. Transport/Aerate toggle switch
3. Aeration engagement button
4. Aeration stop button
5. Parking brake

onto rollers to commence aeration. The switch will override spacing control setting when it is moved to the transport position.

**Aeration Engagement Button** (Fig. 7)—Depressing the button starts water injection system only when the water pressure is above 193 kPa and the rollers are on the ground.

**Aeration Stop Button** (Fig. 7)—This red button stops the water injection system. The system continues for a few seconds after button is pressed.

**Parking Brake** (Fig. 7)—Push the lever toward the machine to engage the parking brake. A warning buzzer will sound if you attempt to move the machine with the parking brake is engaged.

**Fuel Shut-Off Valve**—Located under the fuel tank. Close the fuel shut-off valve when storing or transporting (trailer) the machine.

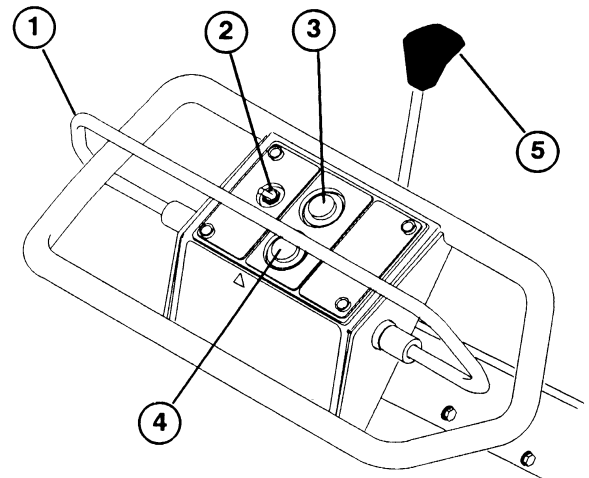

**Figure 7**

1. Traction Ball
2. Transport/Aerate toggle switch
3. Aeration engagement button
4. Aeration stop button
5. Parking brake

# Operation

## OPERATING PRECAUTIONS

1. Before aerating, inspect the work area for debris and determine the best direction and pattern in which to operate the machine.
2. If the machine starts to vibrate abnormally, shut off the engine. Remove the wires from the spark plugs to prevent possible accidental starting. Check the machine for damage and defective parts. Repair any damage before restarting the engine and operating the machine.
3. Use only in daylight or when there is good artificial light. Watch for holes or other hidden hazards. Do not transport the machine close to a sand trap, ditch, creek or other hazard.
4. Always raise the machine to the transport position when parked on a green to prevent roller marks.
5. Do not operate the water injection system on concrete or asphalt because water jets will permanently damage these surfaces. Do not run over hoses because damage will occur.
6. Do not operate the aerator with its roller or injection system over the edge of anything that could be hit, damaged or injured by high-velocity water blasts.
7. Water jets from the injection system should not damage irrigation heads on one pass of the machine. Do not allow multiple shots from the injection system to hit irrigation heads as damage will occur.
8. Use a good, clean, quality water supply in the system. If good quality water is not available, additional filtration equipment may be required. **DO NOT USE CHEMICALS IN THE WATER SYSTEM.**
9. Do not allow the machine to be subject to freezing temperatures without draining, because damage to the system will occur.

## STARTING / STOPPING THE ENGINE

1. Make sure the wires are installed on the spark plugs and the fuel shut-off valve is open.
2. Make sure the parking brake is engaged.
3. Pull the choke lever out to the FULL position and move the throttle lever to the half-throttle position.

**Note:** When starting a warm the engine, the choke may not be necessary, but HALF throttle is.

4. Insert the key into the ignition switch and turn it clockwise to start the engine. Release the key when the engine starts. Gradually return the choke lever to the OFF position (lever all the way in) after the engine starts and warms up.

**IMPORTANT: To prevent overheating the starter motor, do not engage the starter longer than 30 seconds. After 30 seconds of continuous cranking, wait 2 minutes before engaging the starter motor again.**

**IMPORTANT: The engine is equipped with an oil pressure interlock switch which interrupts engine operation if there is not sufficient oil pressure in the engine during starting or during engine operation. The engine may start but will not continue to run due to a lack of oil pressure.**

5. To stop the engine, move the throttle control downward to the SLOW position and turn the ignition key to "OFF".

## TRAINING PERIOD

Before aerating with the Hydroject 3000, it is suggested that you find a clear area and practice starting and stopping, raising and lowering the machine, turning, etc. This training period will be beneficial in gaining confi-

dence in the performance of the Hydroject 3000.

## OPERATING PROCEDURE

1. Make sure the wires are installed on the spark plugs and the fuel shut-off valve is open.
2. Uncoil a garden hose making sure there are no kinks or bends in the hose. Lay out the hose so there are no obstructions between the machine and the area to be aerated. Turn on the water supply to purge any air from the hose. Turn off the water.
3. Connect the hose adapter (Fig. 8) to the garden hose, then connect the adapter to the quick coupler on the side of the machine.
4. Turn on the water supply and check the water pressure. The water pressure must be at least 207 kPa. If system pressure is not 207 kPa, make sure your hose is not kinked or obstructed, the water supply is turned on or if the water filter is plugged.
5. Reach under the fuel tank and press the bleed button on the top of the water filter head (Fig. 9). Hold the bleed button down until all air is purged from the filter and water comes out the opening.
6. Reach under the hood and open the bleed valve on the main valve at rear of the machine (Fig. 10). Bleed the system until a steady flow of water comes from the outlet, then close the valve.
7. If desired, the valve on the pre-filter (Fig. 11) may be opened slightly (cracked) to provide continuous flushing during machine operation.
8. Start the engine: refer to Starting/Stopping instructions. Move the throttle to the FAST position and disengage the parking brake.
9. Engage the traction bail and approach the area to be aerated. Make sure there are no obstructions between the aerator and water supply.
10. Engage and hold the transport/aerate toggle switch to fully lower the machine onto rollers, release the switch when fully lowered, then press the engagement button to start water injection.

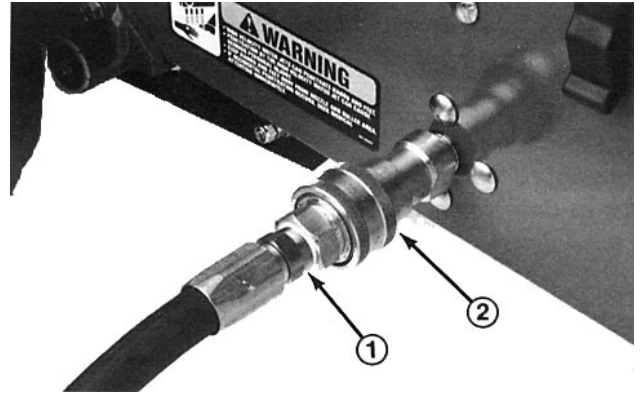

Figure 8

1. Hose adapter
2. Quick coupler

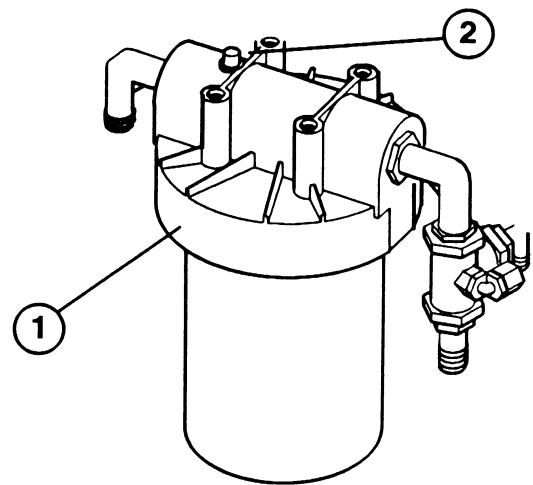

Figure 9

1. Main water filter head
2. Bleed button

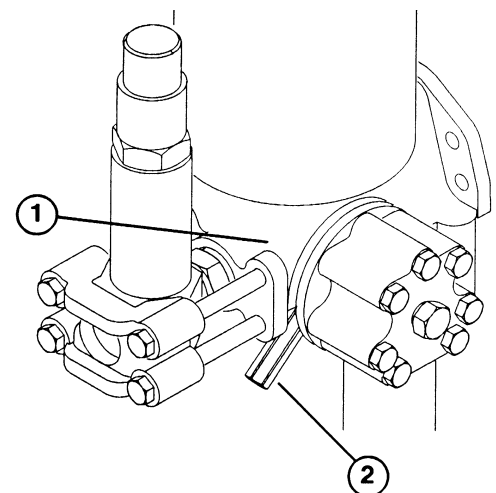

Figure 10

1. Main valve
2. Bleed valve

**Note:** Injection operation starts approximately 4–5 seconds after pump engages. Also, the injection system will automatically stop if the traction bail is not engaged within 3–4 seconds after starting the water system.

11. When aerating, work moving perpendicular from the water supply to avoid running over the garden hose. Use front edge of the hood or rear corner of frame to align rows, if desired. When at the end of a row, make a "S" maneuver and reverse direction of aerator. Do not make sharp turns on a green or scuffing from tire may occur.
12. Regulate the roller spray wash, if required, to remove debris from rollers.

Note: A small amount of water from the regulator by-pass may come out the spray wash nozzles even with spray wash in the "OFF" position.

13. In areas where greater hole depth or more frequent holes are desired, the engage button can be held down to allow multiple shots while the machine is stopped.

**CAUTION:** Hole depths can reach 50.8 cm or more when making multiple shots, so be aware of what is buried below turf. Also, an excessive amount of holes and muddy turf conditions may occur when making multiple shots.

14. To stop water injection, press the red button. The system continues for a few seconds after the button is pressed. Raise the machine to the transport position, disconnect the supply hose and move to next location

## CHECK THE INTERLOCK SYSTEM

The purpose of the safety interlock system is to prevent the engine from cranking or starting unless the traction bail is in NEUTRAL and to prevent the water system from engaging if the machine is in the transport (raised) position. It also stops aeration if the traction bail is released while operating or if the machine is raised to the transport position.

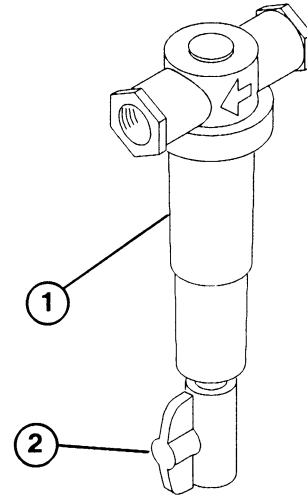

**Figure 11**

1. Pre-filter
2. Valve



## CAUTION

THE INTERLOCK SWITCHES ARE FOR THE OPERATOR'S PROTECTION, SO DO NOT DISCONNECT THEM. CHECK SWITCH OPERATION DAILY TO ASSURE THE INTERLOCK SYSTEM IS OPERATING. IF A SWITCH IS DEFECTIVE, REPLACE IT BEFORE OPERATING THE MACHINE. REPLACE THE SWITCHES EVERY TWO YEARS TO ASSURE MAXIMUM SAFETY. DO NOT RELY ENTIRELY ON SAFETY SWITCHES—USE COMMON SENSE!

To do a functional check of the interlock system:

1. Position the machine in a flat, open area on rough turf away from buried wires, plumbing, etc. Stop the engine.
2. Move the traction bail up and down while trying to start the engine. If the engine cranks, there is a malfunction in the interlock system that must be corrected. If the engine does not crank, go to step 3.
3. Connect the water supply to the machine. Turn on the water supply and bleed all air out of the system. Water pressure must be 30 psi or more. Start the engine. Raise the machine to the transport position (up off the rollers). Push the aerate ENGAGE button. If the water pump engages and the machine begins aerating, there is a malfunction in the interlock system that must be corrected. If the machine does not begin aerating, go to step 4.
4. Lower the machine to the aerate position (on rollers). Engage the traction bail to start the machine moving. Push, then release the aerate ENGAGE button. The water pump should engage immediately, then the machine should begin aerating 5 seconds after pump engages. Release the traction bail to the neutral position so the machine stops moving. The water pump should disengage 4 seconds after the traction bail returns to neutral, then stop aerating after another 3 seconds. If the machine does not stop aerating when the traction bail returns to neutral, there is a malfunction in the interlock system that must be corrected. If the machine stops aerating, go to step 5.
5. Engage the traction bail to start the machine moving, then

push the aerate ENGAGE button to begin aerating. Push the aerate DISENGAGE button. The water pump should disengage immediately, then stop aerating after 3 seconds. If the machine does not stop aerating, there is a malfunction in the interlock system that must be corrected.

**Note:** Lights (LED's) on the controller (Fig. 12) indicate when the following inputs are made to the controller:

**Red:** Transport switch closed (traction bail in neutral).

**Green:** Aerate start (engage) switch closed. If the red and yellow lights are on, the green light will stay on until either red or yellow goes off.

**Yellow:** Pump start limit switch closed (the machine lowered to aerate position) and the water pressure switch closed (water pressure of more than 207 kPa) and accumulator charge pressure switch (nitrogen pressure more than 12,410 kPa).

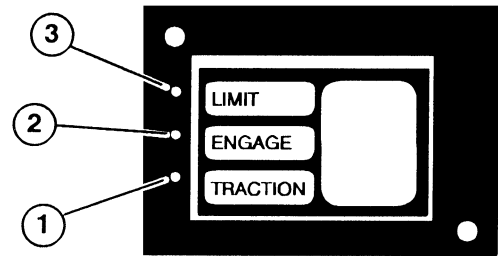

Figure 12

1. Red light
2. Green light
3. Yellow light

## TRANSPORT OPERATION

Use the traction bail to slow the machine while crossing undulating terrain to avoid loss of control. The smooth tires do not grip turf very well so use caution when transporting the machine. Always approach rough areas at a reduced speed and cross severe undulations carefully.

## INSPECTION AND CLEAN-UP AFTER USE

At the completion of operation, thoroughly wash the machine with a garden hose without a nozzle so excessive water pressure will not cause contamination and damage to seals and bearings. After cleaning, inspect for possible hydraulic fluid or water leaks and damage or wear to the hydraulic, water and mechanical components.

## PUSHING OR TOWING THE MACHINE

In an emergency, the machine can be pushed or towed for a very short distance. However, Toro does not recommend this as standard procedure.

**IMPORTANT:** Do not push or tow the machine faster than 4.8 kmh because pump damage may occur. If the machine

**must be moved a considerable distance, transport it on a truck, trailer or pulling it with the traction wheel raised and secured to a dolly. Whenever the machine is pushed or towed the by-pass valve must be opened. Hook on front of handle is used for a tie-down only, not a hitch point.**

1. Unlatch and raise the hood.
2. Locate the by-pass valve cap on left side of hydraulic pump.
3. Turn valve cap counterclockwise, move the machine to the desired location and close the valve cap.
4. Lower the hood and secure the latches.

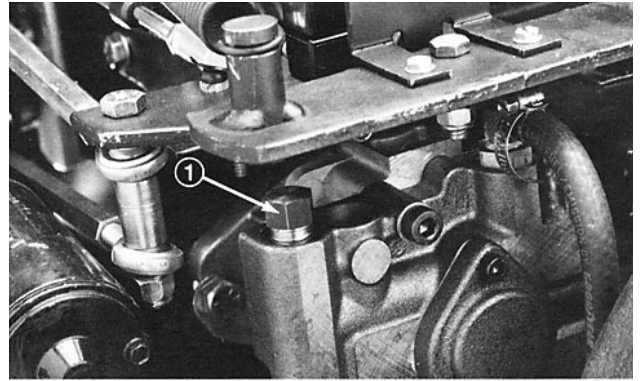

**Figure 13**

1. By-pass valve

# Maintenance

## LUBRICATION



### CAUTION

To avoid personal injury from inadvertent start up or contact with a hot surface, stop the engine, remove the key from the switch and wait for the unit to cool before servicing or making adjustments of the machine.

The Hydroject 3000 has 5 grease fittings that must be lubricated every 25 hours of operation with No. 2 General Purpose Lithium Base Grease.

The bearings and bushings that must be lubricated are: steering pivot shaft (Fig.14), limit switch housing (Fig. 15) (2) on lift arm shaft (Fig. 15) and neutral pivot shaft (Fig. 16).

1. Wipe the grease fitting clean so foreign matter cannot be forced into the bearing or bushing.
2. Pump grease into the bearing or bushing.
3. Wipe up excess grease.

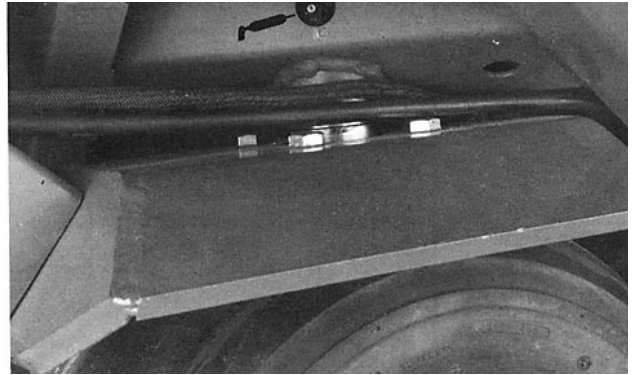

Figure 14

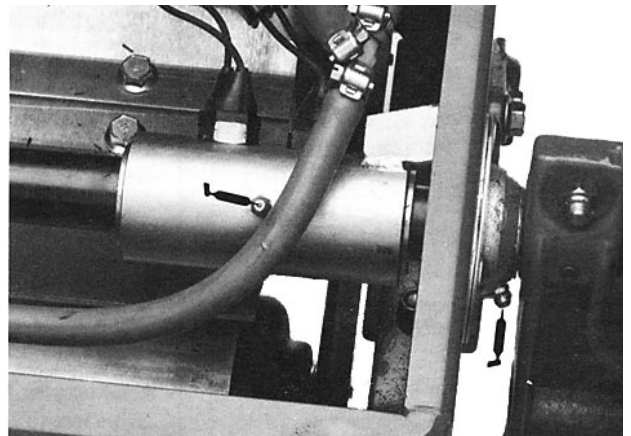

Figure 15

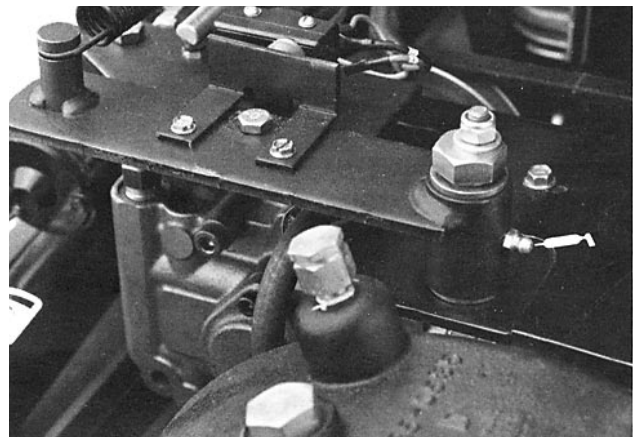

Figure 16

<b>Condition</b>	<b>Cause</b>	<b>Correction</b>
Unit will not move when traction bail is engaged *	<ol style="list-style-type: none"> <li>1. Check that motion occurs at pump pivot plate when the traction ball is moved</li> <li>2. Check oil level In Hydraulic reservoir (gearbox)</li> <li>3. Check that by-pass valve is fully closed (clockwise)</li> <li>4. Check belt tension on traction drive</li> </ol>	<ol style="list-style-type: none"> <li>1. Inspect traction push/pull cable and override assembly under tiller handle</li> <li>2. Replenish If necessary</li> <li>3. Close valve</li> <li>4. Adjust belt tension</li> </ol>
Unit will not transport at full speed*	<ol style="list-style-type: none"> <li>1. Check that unit is fully raised to transport position</li> <li>2. Check oil level in Hydraulic reservoir (gearbox)</li> <li>3. Check that bypass valve is fully closed (clockwise)</li> <li>4. Check belt tension on traction drive</li> <li>5. Check that motion occurs at pump pivot plate when the traction bail is moved</li> </ol>	<ol style="list-style-type: none"> <li>1. Hold lift toggle Swatch until slip clutch in actuator can be heard ratcheting and spindle lift arms are nearly vertical with rear axle spindle tipped away from engine</li> <li>2. Replenish if necessary</li> <li>3. Close valve</li> <li>4. Adjust belt tension</li> <li>5. Inspect traction push/pull cable and override assembly under tiller handle</li> </ol>
Engine dies during startup *	<ol style="list-style-type: none"> <li>1. Fuel shut off valve closed</li> <li>2. Check for fuel in tank</li> <li>3. Check operation of engine choke</li> <li>4. Check engine oil level</li> <li>5. Cold start conditions (30°)</li> </ol>	<ol style="list-style-type: none"> <li>1. Open fuel shut off valve</li> <li>2. Replenish if necessary</li> <li>3. Check choke connections and operation. Regulate choke until engine is warm when starting a cold engine</li> <li>4. The oil pressure switch is by-passed during start but must activate to protect engine while running</li> <li>5. Multiple start attempts may be required to trip oil pressure Switch</li> </ol>
Engine dies when water system is engaged *	<ol style="list-style-type: none"> <li>1. Throttle in wrong operating position</li> <li>2. Check engine speed</li> <li>3. Low engine power</li> </ol>	<ol style="list-style-type: none"> <li>1. Throttle must be in FAST position for aerating</li> <li>2. Adjust carburetor fast setting to 3450–3550 rpm</li> <li>3. Contaminated fuel plugged fuel or air filter bad spark plug</li> <li>4. Have system serviced by an Authorized Toro Distributor</li> </ol>

**\*Make all checks with engine off and parking brake engaged.**

<b>Condition</b>	<b>Cause</b>	<b>Correction</b>
Engine does not start will not engage starter	<ol style="list-style-type: none"> <li>1. Traction bail not in neutral position</li> <li>2. Neutral switch tab out of adjustment</li> <li>3. Battery voltage low</li> <li>4. Malfunction in electrical system</li> </ol>	<ol style="list-style-type: none"> <li>1. Correct position of traction bail</li> <li>2. Adjust switch tab until Red traction light is OFF in neutral.</li> <li>3. Check battery</li> <li>4. Check circuit breaker and electrical connections</li> </ol>
Unit not producing aeration holes (Pump or water valve will not start)	<ol style="list-style-type: none"> <li>1. Check to ensure that transport arms are fully retracted</li> <li>2. Check that water pressure gauge reads</li> <li>3. Check that yellow LED is lit on electronic controller</li> </ol>	<ol style="list-style-type: none"> <li>1. Unit in aerate mode</li> <li>2. Gauge must read 30 psl or more</li> <li>3. Check for loose wires or connections. Have machine checked by an Authorized Toro Distributor.</li> </ol>
Unit not producing aeration holes (Pump shuts down intermittently)*	<ol style="list-style-type: none"> <li>1. Check for kinked supply hose restriction in the line or partially open valve at water source</li> <li>2. Inadequate water pressure or flow from source</li> <li>3. Check water pressure at gauge when pump is engaged If pressure drops to less than 25 psi but was initially higher</li> </ol>	<ol style="list-style-type: none"> <li>1. Correct condition</li> <li>2. Check water pressure (from water source) at inlet (8 gpm - 40 psi)</li> <li>3. Replace water filter.</li> </ol>
Unit stops aerating In one direction or stops aerating in the lowest hole spacing	<ol style="list-style-type: none"> <li>1. Check for kinked supply hose restriction in the line or partially open valve at water source</li> <li>2. Inadequate water pressure or flow from source</li> <li>3. Check water pressure at gauge when pump is engaged If pressure drops to less than 25 psi but was initially higher</li> <li>4. Neutral switch tab out of adjustment</li> </ol>	<ol style="list-style-type: none"> <li>1. Correct condition</li> <li>2. Check water pressure (from water source) at inlet (8 gpm - 40 ps&amp;)</li> <li>3. Replace water filter.</li> <li>4. Adjust switch tab until Red traction light is ON while traction bail is actuated in both directions</li> <li>5. Red traction light must be OFF when in neutral to allow engine start interlock to function</li> </ol>
Unit not producing aeration holes (Pump and valve operating correctly)*	<ol style="list-style-type: none"> <li>1. Air in system</li> <li>2. Plugged nozzle(s)</li> <li>3. Soil composition (hard)</li> </ol>	<ol style="list-style-type: none"> <li>1. Open main bleed valve to purge air from system</li> <li>2. Inspect nozzles</li> <li>3. Different nozzle configuration required</li> <li>4. Have water system checked by an Authorized Toro Distributor</li> </ol>

**\*Make all checks with engine off and parking brake engaged.**

Condition	Cause	Correction
Unit not producing aeration holes (Injection pump stops after unit stops moving) *	1. Normal condition of neutral interlock system	1. Operator must hold Engage (start) button to aerate without moving
Shallow or Improper hole depth *	1. Air in system 2. If hole depth was satisfactory earlier check density and moisture content in soil. 3. Soil composition (hard) 4. Too many large nozzles will cause a loss in pressure and could damage accumulator or other water system components	1. Open main bleed valve to purge air from system 2. Different nozzle configuration may be required 3. Different nozzle configuration may be required 4. Open bleed valve and examine nozzles. Verify size and quantity per the recommendation chart. 5. Have water system checked by Authorized Toro Distributor
Water Injection system making unusual noise when aerating *	1. Air in system 2. Missing nozzle or too many large nozzles installed 3. Broken springs in nozzle extension check valve. 4. Gear box drive shaft or couplers worn	1. With water supply on open bleed valve under accumulator/ valve body. If mechanical noise continues during aeration stop unit and have it serviced by an Authorized Toro Distributor. 2. Open bleed valve and examine nozzles. Verify size and quantity per the recommendation chart. 3. Replace springs inspect ball and seat. 4. Remove drive shaft guard and repair or replace as necessary.

**\*Make all checks with engine off and parking brake engaged.**

## SERVICING THE PRE-FILTER (Fig. 17)

Sediment can be removed by opening the ball valve, with the water source attached, to flush. The reusable filter screen may be removed for cleaning by untwisting the clear cover from the filter by hand. Replace the clear cover and hand tighten only.

**IMPORTANT:** Use of tools will damage the filter.

## REPLACING THE MAIN WATER FILTER (Fig. 18)

The machine is a precision piece of equipment and the quality or cleanliness of your water supply is very important in determining its useful life. If your water supply contains silt, sand or other debris, you may be required to install additional filtration or separation equipment between your supply source and the machine. Depending on the quality of your water, frequency of filter change will vary greatly. When pump inlet pressure decreases or the water system shuts down, it usually means the water filter is restricted and must be replaced. Never operate the machine without a water filter as severe damage may occur.

1. Position the machine on a level surface and make sure the engine is shut off. Shut off the water supply.
2. Locate the main water filter assembly mounted below the fuel tank. Press the bleed button to release air pressure from the filter body.
3. Unscrew the filter body of the assembly counterclockwise (as viewed from the bottom). Remove the filter cartridge and discard.

**Note:** To ease the removal of the filter body from the filter head, a filter wrench is available. Contact your Authorized Toro Distributor.

**CAUTION:** The water filter body is very heavy when filled with water and filter. Use caution when unscrewing the filter body from the filter head.

4. Thoroughly rinse out the filter body to avoid contaminating the water system. Make sure the "O" ring is in the groove. If it has come out, wipe it dry, lubricate it with a light coating of petroleum jelly and replace it in the groove.
5. Thoroughly clean the filter head mounting surface to avoid

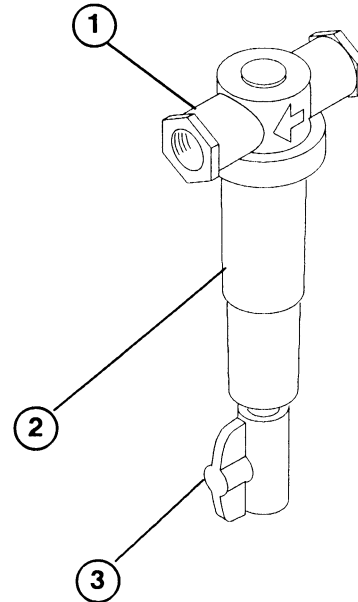

Figure 17

1. Body
2. Clear cover
3. Ball valve for flushing

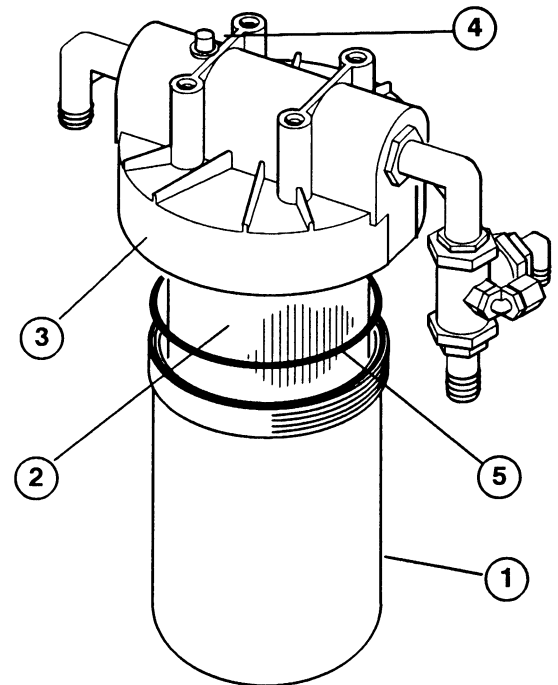

Figure 18

1. Filter body
2. Filter Cartridge
3. Filter head
4. Bleed button
5. O-ring

contaminating the water system when the filter is installed.

6. Insert the new filter cartridge into the filter body.
7. Thread the filter body with the filter onto the filter head. Hand tighten.
8. Turn on the water supply and press the bleed button on the top of the water filter head. Hold the bleed button down until all air is purged from the filter and water comes out opening.

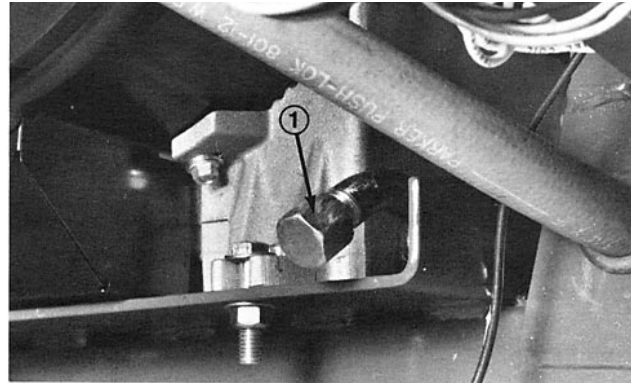

Figure 19

1. Drain cap

## CHANGING THE ENGINE OIL AND FILTER

For new engines, change the oil after first 25 operating hours. Thereafter, under normal conditions, change the oil and filter after every 100 hours of operation. However, an engine operated in dusty or dirty conditions requires more frequent oil changes. If possible, run the engine just before changing the oil. Warm oil flows more freely and carries more contaminants than cold oil.

1. Position the machine on a level surface.
2. Disengage the hood latches and open the hood.
3. Place an oil drain pan below the drain cap on the bottom of the crankcase. Clean the area around the drain cap.
4. Remove the drain cap and allow the oil to flow into the drain pan. After the oil is drained, install the oil drain cap.
5. Remove the oil filter and discard. Thoroughly clean the filter mounting surface and make sure a new gasket is installed in the new filter.
6. Apply a thin film of clean oil to gasket. Install the new filter by hand until the gasket just touches the mounting surface, then turn an additional 1/2 to 3/4 turn.
7. Remove the filler cap and pour 3 quarts of oil having the API "service classification" SF or SG into the filler neck. Recommended viscosity (weight) of oil is SAE 30.
8. Start the engine and check for leaks around the oil filter. Tighten the filter only enough to eliminate leaks. **DO NOT OVERTIGHTEN.**

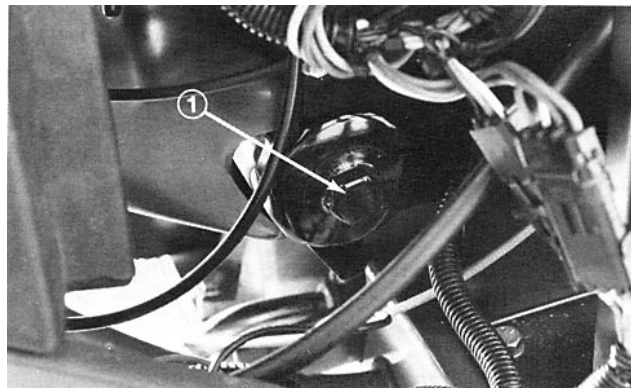

Figure 20

1. Oil filter

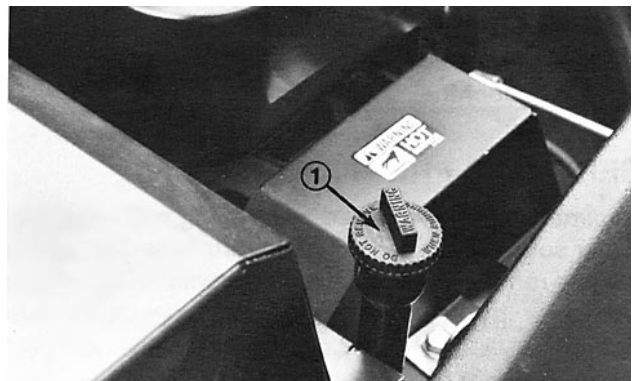

Figure 21

1. Filter cap

9. Turn off the engine and allow the machine to stand for 2 minutes.
10. Check the oil and make sure the level is up to the FULL mark on the dipstick. Add more oil if the level is low; however, DO NOT OVERFILL.
11. Lower the hood and secure the latches.

## SERVICING THE AIR CLEANER

The foam pre-cleaner must be cleaned and re-oiled and the paper element must be checked and/or replaced after every 100 hours of engine operation. However, the air cleaner must be cleaned more frequently if operating conditions are extremely dusty or sandy.

1. Remove the knob and cover from the air cleaner.
2. Remove the foam pre-cleaner by sliding it off the paper element.
3.
  - A. Wash the foam pre-cleaner in detergent soap and warm water.
  - B. Wrap the foam pre-cleaner in a cloth and squeeze dry. Do not wring the pre-cleaner.
  - C. Add and evenly distribute one tablespoon of engine oil to the foam pre-cleaner. Squeeze the foam pre-cleaner to remove excess oil.
4. Reinstall the pre-cleaner on the paper element.

Inspect the paper element every 100 hours of operation and replace when dirty or damaged. Do not wash the paper element or do not clean it with compressed air as damage will occur.

**Note:** With the air cleaner disassembled, check the air cleaner components for damage. Replace if necessary.

5. Reinstall the paper element with the foam pre-cleaner, air cleaner element cover, nut, air cleaner cover and knob.
6. Tighten the knob 1/2 to 1 turn after it contacts cover. Do not overtighten.

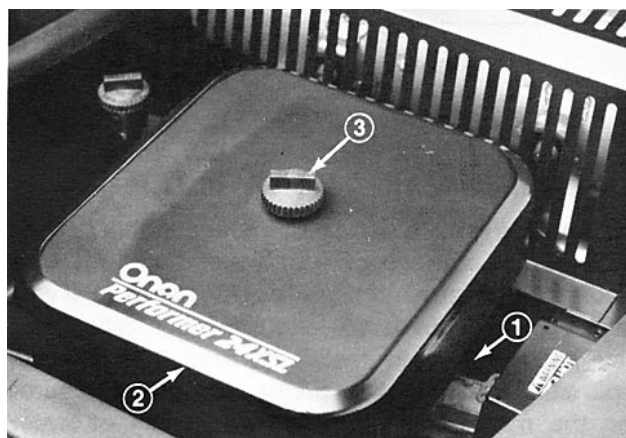

Figure 23

1. Air cleaner
2. Air cleaner cover
3. Knob

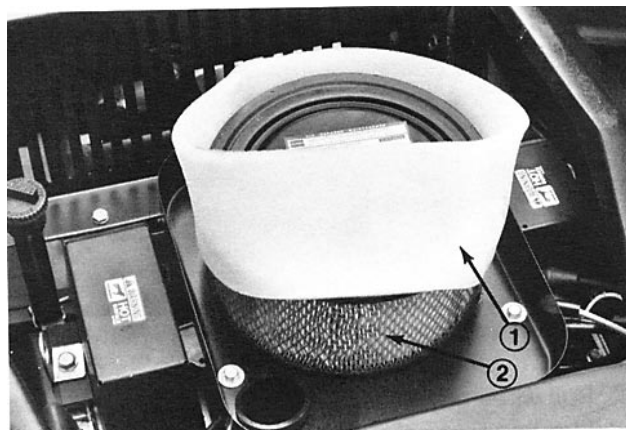

Figure 24

1. Foam pre-cleaner
2. Paper element

## CHECKING AND REPLACING THE SPARK PLUG

Since the air gap between center and side electrodes increases gradually during normal engine operation, check condition of the electrodes at 100 hour intervals. The correct spark plug to use in the engine is a Champion RS14 YC or equivalent. Set the air gap at ,06 mm.

## CLEANING THE CYLINDER HEAD FINS

To avoid overheating and possible engine damage, clean the cooling fins on the cylinder head every day if necessary.

1. Disengage the hood latches and open the hood.
2. Pull the wires off the spark plugs.
3. Clean dirt, grass and chaff from the outside of the cylinder, cylinder head fins and the air intake screen.
4. Push the wires onto the spark plugs.
5. Lower the hood and secure the latches.

## CHANGING THE GEAR CASE OIL AND FILTER

Change the hydraulic oil and filter initially after 25 hours of operation; thereafter change every 250 hours of operation. The gear case oil and filter must be changed immediately when any contamination, sludge, water or condensation appears.

1. Disengage the hood latches and open the hood.
2. Place a drain pan under the bottom of the gear case. Clean the area around the drain plug.

**Note:** When draining oil, use a funnel or some type of channel to divert draining oil away from machine components and into the drain pan.

3. Remove the drain plug and allow the oil to flow into the drain pan. After the oil is drained, install the oil drain plug.
4. Remove the oil filter (Fig. 25), mounted below the control



Figure 24

1. Drain plug location

panel base, and discard the filter. Thoroughly clean the filter mounting surface and make sure a new gasket is installed in the new filter.

5. Fill the new filter with new Mobil DTE 26 hydraulic oil or equivalent oil (refer to fluid recommendation table). Apply a thin film of clean oil to the filter gasket.
6. Install the new filter by hand until the gasket just touches the mounting surface, then turn an additional 1/2 to 3/4 turn.
7. Remove the filler cap and add 3.8–4.7 l of Mobil DTE 26 hydraulic oil or equivalent oil (refer to fluid recommendation table) to the gear case reservoir. Install the filler cap.
8. Check for leaks around the oil filter. Tighten the filter only enough to eliminate leaks. **DO NOT OVERTIGHTEN.**
9. Lower the hood and secure the latches.

## CHANGING THE PUMP CASE OIL (Fig. 26)

Change pump oil initially after 25 hours of operation, thereafter change every 250 hours of operation. The pump case oil must be changed immediately when any contamination, sludge, water or condensation appears.

1. Disengage the hood latches and open the hood.
2. Place a drain pan under pump case. Clean area around the drain plug on bottom of case.  
**Note:** When draining oil, use a funnel or some type of channel to divert draining oil away from machine components and into the drain pan.
3. Remove the drain plug and allow the oil to flow into the drain pan. After the oil is drained, install the oil drain plug.
4. Remove the dipstick/filler cap and add approximately 1182 ml of Mobil DTE Extra-Heavy oil or equivalent oil (refer to fluid recommendation table) to the pump case. Install the filler cap.
5. Check the oil level. If the fluid level is low, add enough Mobil DTE Extra-Heavy oil or equivalent to bring the oil



Figure 25

1. Oil filter

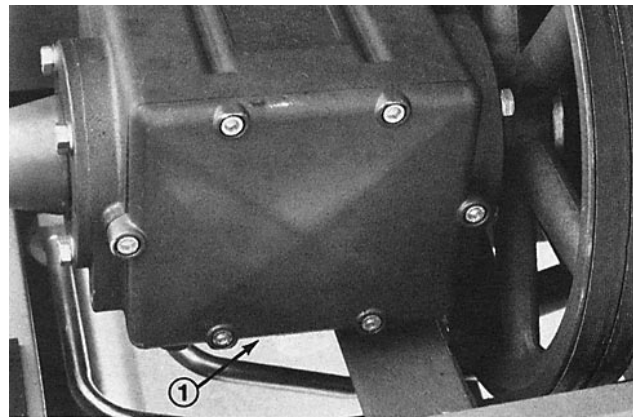

Figure 26

1. Drain plug location

up to proper level. DO NOT OVERFILL.

6. Check for possible leaks. Lower the hood and secure the latches.

## CHECKING HYDRAULIC LINES AND HOSES

After every 100 operating hours, check hydraulic lines and hoses for leaks, kinked lines, loose mounting supports, wear, loose fittings, weather deterioration and chemical deterioration. Make all necessary repairs before operating.

## ADJUSTING ROLLER SPRAY WASH SYSTEM (Fig. 27)

If the spray wash system (Fig. 27) on the rollers needs to be adjusted, proceed as follows:

1. Loosen the cap on bottom of the fitting.
2. Rotate nozzle so the slot in tip is parallel to the roller.
3. Tighten the cap and check the adjustment.

## SERVICING SPRAY WASH NOZZLES or STRAINERS (Fig. 28)

To clean or replace strainers in the spray wash nozzles proceed as follows:

1. Loosen and remove the cap on the bottom of the fitting.
2. Remove the nozzle and strainer assembly. Clean or replace the strainer and replace it in the nozzle.
3. Loosely secure the nozzle and strainer to the fitting with the cap.
4. Rotate the nozzle so that the slot in its tip is parallel to the roller.
5. Tighten the cap and check the adjustment.

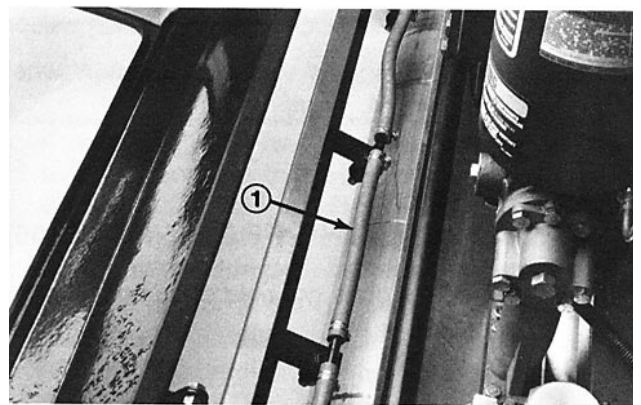
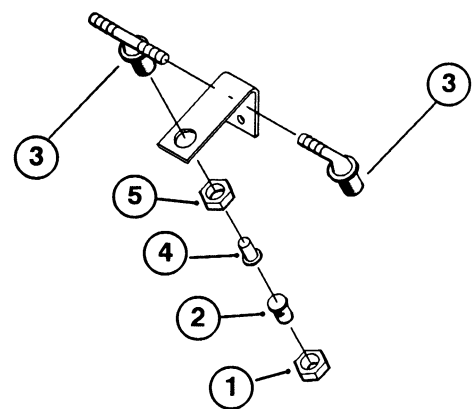

Figure 27

1. Roller spray wash system

Figure 28



1. Fitting cap
2. Nozzle
3. Fitting
4. Strainer
5. Hex nut

## BATTERY CARE

1. Battery electrolyte level must be properly maintained and the top of the battery must be kept clean. If the Aerator is stored in a location where temperatures are extremely high, the battery will run down more rapidly than if the machine is stored in a location where temperatures are cool.
2. Check the electrolyte level every 25 operating hours or, if the machine is in storage, every 30 days.
3. Maintain cell level with distilled or demineralized water. Do not fill the cells above the bottom of the split ring inside each cell.
4. Keep the top of the battery clean by washing it periodically with a brush dipped in ammonia or bicarbonate of soda solution. Flush the top surface with water after cleaning. Do not remove the caps while cleaning.
5. Battery cables must be tight on the terminals to provide good electrical contact.
6. If corrosion occurs at terminals, disconnect the cables—negative (–) cable first—and scrape the clamps and terminals separately. Reconnect the cables—positive cable first—and coat the terminals with petroleum jelly.
7. If the machine will be stored more than 30 days, remove the battery and charge it fully. Either store it on the shelf or on the machine. Leave the cables disconnected if stored on the machine. Store the battery in a cool atmosphere to avoid quick deterioration of the battery charge.

## SEASONAL STORAGE

### Water System

It is important that the water system be drained to avoid freezing and damaging the components. Drain the system as follows:

1. Stop the engine, remove the key from the ignition switch and remove the wires from the spark plugs.
2. Remove the (2) screws securing the drive shield to the frame and remove the shield.

3. With the engine "OFF" and the key removed from the ignition, rotate the drive coupling by hand until resistance is felt. Continue to turn the coupling about 1/4 revolution, opening the the cycling valve.
4. Using the appropriate reducers, connect a source of compressed air (maximum pressure 1,034 kPa; minimum pressure 621 kPa;) to the water inlets on either side of the machine.

**DANGER:** Compressed air can penetrate the skin and cause physical harm. Use extreme caution and wear protective goggles and gloves when working with high-pressure air. Get prompt medical attention if an injury occurs.

5. Let compressed air flow through the machine for 3 minutes. While compressed air is flowing, temporarily open the spray wash and high-pressure drain valve, purging water from the spray wash and the high-pressure system.
6. Disconnect compressed air and reducers. Install the drive shield previously removed and tighten the relief valve tube.
7. Remove and drain the water filter container. Install the new filter and replace the filter container.

## Engine

1. Drain the engine oil from the oil pan and replace the drain cap.
2. Remove and discard the oil filter. Install a new filter.
3. Refill the engine with 3 qts. of recommended SAE 30 wt. motor oil.
4. Start the engine and run at idle speed for two minutes. **DO NOT RUN LONGER THAN TWO MINUTES.**
5. Stop the engine; remove the spark plugs.
6. Pour 29 ml of clean engine oil into the spark plug holes.
7. With the spark plugs removed, crank the engine with the starter for a least 12 revolutions to distribute the oil in the cylinders.

8. Reinstall the spark plugs.
9. Drain the gasoline from the fuel tank and fuel lines. Reinstall all lines and secure all connections.
10. Thoroughly clean and service the air cleaner.
11. Check the oil filler cap and the fuel tank cap to ensure they securely in place.

## Traction Unit

1. Thoroughly clean the machine.
2. Grease or oil all fittings or pivot points.
3. Check to make sure all tires are over inflated to 137–207 kPa.
4. Lightly sand and use touch up paint on all areas that are scratched, chipped or rusted.
5. Drain and replace the hydraulic oil and filter on the cam gear case.
6. Drain and replace the oil in the water pump case.
7. Clean the battery, terminals and posts with a wire brush and baking soda solution. Coat the cable terminals and battery posts with grease or petroleum jelly. Recharge the battery.

## Service Interval Chart

Check Pump Case Oil	Daily
Check Engine Oil Level	Daily
Check Hydraulic Oil Level	Daily
Check Safety Interlock Switch Operation	Daily
Check Water Filter/Pressure	Daily
Change Gear Case Hydraulic Oil & Filter(Initial)	25 hours
Change Engine Oil (Initial)	25 hours
Change Pump Case Oil (Initial)	25 hours
Check Tire Pressure	25 hours
Check Hoses, Lines & Housings for Leaks	25 hours
Lubricate Grease Fittings (5 locations)	25 hours
Check Battery	25 hours
Clean Spray Wash Tips & Strainer	100 hours
Change Engine Oil & Filter	100 hours
Clean Air Cleaner (Clean & re-oil Foam Pre Cleaner)	100 hours
Check Accumulator Pre Charge*	100 hours
Check Engine RPM	100 hours
Adjust Parking Brake	250 hours
Change Gear Case Hydraulic Oil & Filter	250 hours/Seasonal
Change Pump Case Case Oil	250 hours/Seasonal
Check/Adjust Water System Cam/Valve	250 hours/Seasonal
Change Fuel Filter	250 hours/Seasonal
Clean Engine Cooling Fins	250 hours/Seasonal
Adjust Traction Spacing	250 hours/Seasonal
Adjust Clutch / Brake*	250 hours/Seasonal
Change Air Filter Element	250 hours/Seasonal
Recharge Accumulator*	250 hours/Seasonal
Clean/Decarbon Combustion Chamber & Intake Port (If using leaded fuel)*	250 hours
Replace Spark Plugs	500 hours
Adjust Engine Valve Lash*	500 hours
Clean Engine Breather*	500 hours
Inspect Nozzles/Springs*	500 hours
Check Water System Performance	500 hours

\* Have machine serviced by an Authorized Toro Distributor.





