



MODEL NO. 03422 60001 thru 80001 & UP
 MODEL NO. 03422TE 60001 thru 80001 & UP
 MODEL NO. 03427 60001 thru 80001 & UP
 MODEL NO. 03427TE 60001 thru 80001 & UP

OPERATOR'S MANUAL

REELMASTER 2300/2600-D TRACTION UNIT

To assure maximum safety, optimum performance, and to gain knowledge of the product, it is essential that you or any other operator of the mower read and understand the contents of this manual before the engine is ever started. Pay particular attention to the **SAFETY INSTRUCTIONS** highlighted by this symbol.

The safety alert symbol means **CAUTION, WARNING** or **DANGER** – personal safety instruction. Failure to comply with the instruction may result in personal injury.



FOREWORD

The REELMASTER was developed to provide an efficient, reliable and time-saving method of mowing high quality turf. The latest concepts in engineering and design have been incorporated into this machine along with the highest quality parts and workmanship. Excellent service will be derived if proper operation and maintenance practices are followed.

We know, since you have purchased the industry leader in mowing excellence, that future performance and dependability are of prime importance. TORO also is concerned about future use of the machine and of the safety to the user. Therefore, this manual should be read by you and those involved with the REELMASTER to ensure that safety, proper set-up, operation and maintenance procedures are followed at all times. The major sections of the manual are:

1. Safety Instructions
2. Set-up Instructions
3. Before Operating Instructions
4. Operating Instructions
5. Maintenance

Safety, mechanical and some general information in this manual is emphasized. DANGER, WARNING and CAUTION identify safety messages. Whenever the triangular safety alert symbol appears, it is followed by a safety message that must be read and understood. For more complete details concerning safety, read the safety instructions on pages 4 and 5. IMPORTANT identifies special mechanical information and NOTE identifies general information worthy of special attention.

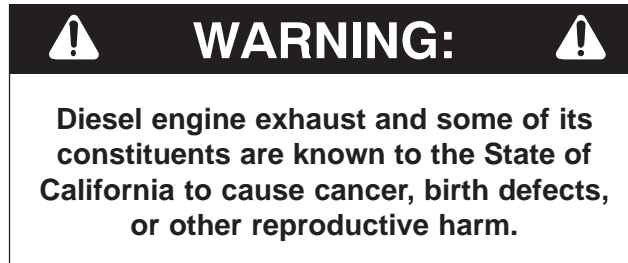

Whenever you have questions or need service, contact your local authorized Toro Distributor. In addition to having a complete line of accessories and professional turf care service technicians, the distributor has a complete line of genuine TORO replacement parts to keep your machine operating properly. Keep your TORO all TORO. Buy genuine TORO parts and accessories.

TABLE OF CONTENTS

| | Page | | Page |
|---|-------|---|------------|
| SAFETY INSTRUCTIONS | 4–5 | Training Period | 22 |
| SAFETY INSTRUCTIONS & DECALS | 6 | Before Mowing | 23 |
| SPECIFICATIONS | 7 | Transport Operation | 23 |
| LOOSE PARTS CHART | 8 | Inspection and Clean—Up After Mowing | 23 |
| SET-UP INSTRUCTIONS | 9–14 | DAILY MAINTENANCE CHECKLIST | 24 |
| Install Rear Wheel | 9 | MAINTENANCE SCHEDULE | 25 |
| Installing Seat | 9 | SERVICE INTERVAL CHART | 26 |
| Adjust Rear Carrier Frame Height | 10 | LUBRICATION | 26–27 |
| Mount Carrier Frames To Cutting Units | 10 | MAINTENANCE | 28–33 |
| Install Front Lift Arms | 10 | Hood Removal | 28 |
| Mount Cutting Unit Drive Motors | 11 | General Air Cleaner Maintenance | 28 |
| Mount Cutting Units | 11 | Servicing Air Cleaner | 28 |
| Install Counterbalance Springs | 12 | Cleaning Radiator and Screen | 29 |
| Add Rear Ballast | 13 | Changing Engine Oil and Filter | 29 |
| Affix Decals | 13 | Changing Hydraulic System Fluid and Filter .. | 29 |
| Activate and Charge Battery | 13 | Hydraulic System Test Ports | 30 |
| BEFORE OPERATING | 15–17 | Replacing Fuel Filter | 30 |
| Check Crankcase Oil | 15 | Adjusting Transmission For Neutral | 31 |
| Fill Fuel Tank | 15 | Belt Adjustments | 31 |
| Check Cooling System | 15 | Adjusting Traction Pedal | 32 |
| Check Hydraulic System Fluid | 16 | Adjusting Traction Pedal Damper | 32 |
| Inspect Fuel Filter | 17 | Hand Brake Adjustment | 32 |
| Check Tire Pressure | 17 | Adjust Valve Clearance | 33 |
| Check Reel To Bedknife Contact | 17 | Torque Cylinder Head Bolts | 33 |
| Check Torque Of Wheel Nuts | 17 | Battery Care | 33 |
| CONTROLS | 18–19 | Battery Storage | 33 |
| OPERATING INSTRUCTIONS | 19–23 | Fuses | 33 |
| Starting/Stopping Engine | 20 | BACKLAPPING | 34 |
| Bleeding Fuel System | 20 | ELECTRICAL SCHEMATIC | 35 |
| Check Operation of Interlock Switches | 21 | HYDRAULIC SCHEMATICS | 36–37 |
| Towing Traction Unit | 21 | SLOPE CHART | 38 |
| Operating Characteristics | 21 | IDENTIFICATION AND ORDERING | 39 |
| Selecting Clip Rate (Reel Speed) | 22 | THE TORO PROMISE | Back Cover |



SAFETY INSTRUCTIONS

Improper use or maintenance by the operator or owner of the machine can result in injury. To reduce the potential for any injury, comply with the following safety instructions.

BEFORE OPERATING

1. Operate the machine only after reading and understanding the contents of this manual. A free replacement manual is available by sending complete model and serial number to:

The Toro Company
8111 Lyndale Ave. S.
Bloomington, MN 55420–1196.

2. Only trained operators, skilled in slope operation and who have read this manual should operate the machine. Never allow children to operate the machine or adults to operate it without proper instructions.

3. **IMPORTANT:** Always use proper rear ballast as specified in this manual; see Rear Ballast.

4. Become familiar with the controls and know how to stop the machine and engine quickly.

5. Do not carry passengers on the machine. Keep everyone, especially children and pets, away from the areas of operation.

6. Keep all shields, safety devices and decals in place. If a shield, safety device or decal is damaged, malfunctioning or illegible, repair or replace it before operating the machine.

7. Always wear substantial shoes. Do not operate machine while wearing sandals, tennis shoes or sneakers. Do not wear loose fitting clothing because it could get caught in moving parts and possibly cause personal injury.

8. Wearing safety glasses, safety shoes, long pants and a helmet is advisable and required by some local ordinances and insurance regulations.

9. Make sure the work area is clear of objects which might be picked up and thrown by the reels.

10. Fill fuel tank with diesel fuel before starting engine. Avoid spilling any fuel. Since fuel is highly flammable, handle it carefully.

- A. Use an approved fuel container.
- B. Do not remove cap from fuel tank when engine is hot or running.
- C. Do not smoke while handling diesel fuel.
- D. Fill fuel tank outdoors and not over one inch from the top of the tank, (bottom of the filler neck). Do not overfill.

WHILE OPERATING

11. Do not run the engine in a confined area without adequate ventilation. Exhaust fumes are hazardous and could be deadly.

12. Sit on the seat when starting and operating the machine.

13. Check interlock switches daily for proper operation (Refer To Checking Interlock Switches, Page 21). Do not rely entirely on safety switches -shut off engine before getting off seat. If a switch fails, replace it before operating the machine. The interlock system is for your protection, so do not bypass it. Replace all interlock switches every two years.

14. When starting the engine:

- A. Engage parking brake.
- B. Be sure traction pedal is in neutral and reel drive is in disengage position.
- C. After engine starts, release parking brake and keep foot off traction pedal. Machine must not move. If movement is evident, the neutral control linkage is incorrectly adjusted: therefore, shut engine off and adjust until machine does not move when traction pedal is released. Refer to Adjusting Transmission for Neutral.
- D. Hills over 15 degrees should be mowed up and down, not side to side; see slope chart.
- E. Mowing hills may be dangerous. However, hills over 20 degrees generally should not be mowed unless special safeguards, skills and conditions exist; see slope chart.
- F. Stay alert for holes in terrain and other hidden hazards. Use extreme care when operating close to sand traps, ditches, creeks, steep hillsides or other hazards.
- G. Reduce speed when making sharp turns. Avoid sudden stops and starts. Use reverse pedal for braking. Cutting units must be lowered when going down slopes for steering control.
- H. Before backing up, look to the rear and assure no one is behind the machine. Watch out for traffic when near or crossing roads. Always yield the right of way.

15. Keep hands, feet and clothing away from moving parts and the reel discharge area. Grass baskets, if so equipped, must be in place during reel operation for maximum safety.

16. This product may exceed noise levels of 85 dB(A) at the operator position. Ear protectors are recommended for prolonged exposure to reduce the potential of permanent hearing damage.

17. Raise the cutting units when driving from one work area to another.



SAFETY INSTRUCTIONS

18. Do not touch engine, muffler, exhaust pipe or hydraulic tank while engine is running or soon after it has stopped because these areas could be hot enough to cause burns.

19. If a cutting unit strikes a solid object or vibrates abnormally, stop immediately. Turn engine off, wait for all motion to stop and inspect for damage. A damaged reel or bedknife must be repaired or replaced before operation is continued.

20. Before getting off the seat:

- A. Move traction pedal to neutral.
- B. Set the parking brake.
- C. Disengage the cutting units and wait for the reels to stop spinning.
- D. Stop the engine and remove key from the ignition switch.

21. Whenever machine is left unattended, make sure reels are not spinning, key is removed from ignition switch and parking brake is set.

MAINTENANCE

22. Before servicing or making adjustments to the machine, stop the engine and remove key from switch to prevent accidental starting of the engine.

23. Check performance of all interlock switches daily. Do not defeat interlock system. It is for your protection.

24. To ensure entire machine is in good operating condition, frequently check and keep all nuts, bolts, screws and hydraulic fittings tight.

25. Make sure all hydraulic line connectors are tight, and all hydraulic hoses and lines are in good condition before applying pressure to the system.

26. Keep body and hands away from pin hole leaks or nozzles that eject hydraulic fluid under high pressure. Use paper or cardboard, not hands, to search for leaks. Hydraulic fluid escaping under pressure can have sufficient force to penetrate skin and do serious damage. If fluid is injected into the skin it must be surgically removed within a few hours by a doctor familiar with this form of injury or gangrene may result.

27. Before disconnecting or performing any work on the hydraulic system, all pressure in system must be relieved by stopping engine and lowering cutting units to the ground.

28. If major repairs are ever needed or if assistance is desired, contact an Authorized Toro Distributor.

29. To reduce potential fire hazard, keep the engine area free of excessive grease, grass, leaves and accumulation of dirt.

30. If the engine must be running to perform a maintenance adjustment, keep hands, feet, clothing, and any other parts of the body away from the cutting units and any moving parts. Keep everyone away.

31. Do not overspeed the engine by changing governor settings. To assure safety and accuracy, have an Authorized Toro Distributor check maximum engine speed with a tachometer.

32. Engine must be shut off before checking oil or adding oil to the crankcase.

33. To insure optimum performance and safety, use genuine TORO replacement parts and accessories. Replacement parts and accessories made by other manufacturers could be dangerous, and such use could void the product warranty of The Toro Company

SOUND PRESSURE LEVEL

This unit has an equivalent continuous A-weighted sound pressure at the operator ear of: 85 dB(A), based on measurements of identical machines per Directive 84/538/EEC and amendments.

VIBRATION LEVEL

Hand-Arm

This unit does not exceed a vibration level of 5.5 m/s² at the hands based on measurements of identical machines per ISO 5349 procedures.

Whole Body

This unit does not exceed a vibration level of .5 m/s² at the posterior based on measurements of identical machines per ISO 2631 procedures.



SAFETY AND INSTRUCTION DECALS

The following safety and instruction decals are affixed to the traction unit. If any decal becomes illegible or damaged, install a new decal. Part numbers are listed below and in your Parts Catalog. Order replacements from your Authorized Toro Distributor.

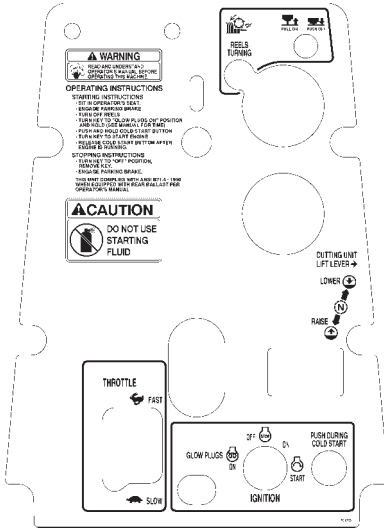

ON INSTRUMENT PANEL
(Part No. 94-4985)

| | | | | | | | | | | | | |
|---|--|-------------------------------|-----|-----|-----|-----|--|---------------------------|-----|-----|---|---|
| 3 | | 2 1/4" (64mm) - 2 1/2" (60mm) | 3 | 5 | - | 3 | | 1 1/4" (32 mm) | 7 | - | 4 | 6 |
| | | | 3WD | 2WD | 3WD | 2WD | | | 3WD | 2WD | | |
| 9 | | 2 1/4" (67mm) - 2 1/4" (54mm) | 4 | 5 | - | 3 | | 1 1/4" (29 mm) | 7 | - | 5 | 7 |
| | | | 3WD | 2WD | 3WD | 2WD | | | 3WD | 2WD | | |
| | | 2" (51 mm) | 4 | 6 | - | 3 | | 1" (25 mm) | 8 | - | 5 | 9 |
| | | | 3WD | 2WD | 3WD | 2WD | | | 3WD | 2WD | | |
| | | 1 1/4" (48 mm) | 4 | 6 | 3 | 4 | | 7/8" (22 mm) | 9 | - | 6 | - |
| | | | 3WD | 2WD | 3WD | 2WD | | | 3WD | 2WD | | |
| | | 1 1/4" (44mm) - 1 1/4" (41mm) | 5 | 7 | 3 | 4 | | 7/8" (19 mm) | - | - | 7 | - |
| | | | 3WD | 2WD | 3WD | 2WD | | | 3WD | 2WD | | |
| | | 1 1/4" (38mm) - 1 1/4" (35mm) | 6 | - | 4 | 5 | | 5/8" (16mm) - 7/8" (10mm) | - | - | 9 | - |
| | | | 3WD | 2WD | 3WD | 2WD | | | 3WD | 2WD | | |

ON HOOD HINGE
(Part No. 94-5056)

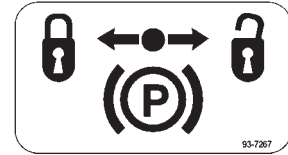

ON LEFT FENDER
(Part No. 93-7267)

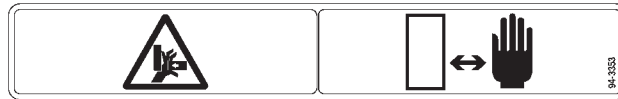

ON CARRIER FRAME
(Part No. 94-3353)
Warning! Pinch Point Between
Carrier Frame and Cutting Unit



ON FAN SHROUD
(Part No. 77-3100)
Rotating Parts

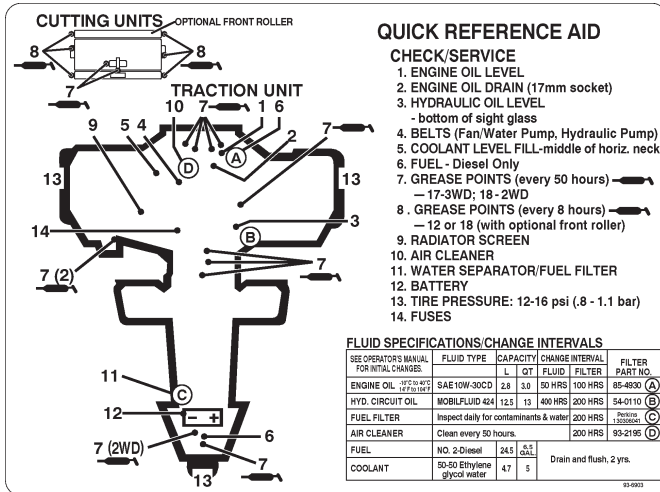

ON UNDER SEAT
(Part No. 93-6903)

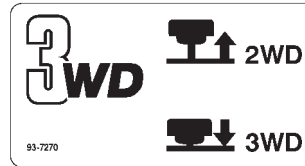

ON LEFT SIDE OF SEAT PANEL
(Part No. 92-7270)
Model 03427 only



ON LIFT ARMS
(Part No. 93-6696)
Warning! Spring Loaded Mechanism,
Read Disassembly Procedure



ON INSIDE OF FRONT RIGHT PANEL
(Part No. 67-5360)

| | |
|-------------|------|
| CHARGING | 20 A |
| ACCESSORIES | 10 A |
| ENGINE | 10 A |
| OPEN | |
| FUSES | |

UNDER CONTROL PANEL
(Part No. 93-6902)

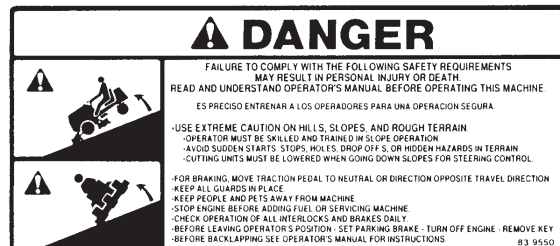

ON SKIRT PANEL
(Part No. 83-9550)

SPECIFICATIONS

Engine: Perkins, 4 cycle, 3 cylinder, liquid cooled, vertical OHV, diesel engine with centrifugal water pump. 18 hp (13.4 kW); governed to a maximum speed of 3200 rpm. 41.2 cu. in. (676 cc) displacement. Forced lubrication gear pump. Mechanical centrifugal governor. Mechanical fuel transfer pump. Fuel filter/water separator with replaceable filter element. 12 volt (0.7 kW) starter. Heavy duty remote mounted air cleaner Spin-on oil filter.

Radiator: Side mounted Industrial radiator, 7 fins per inch. Approx. 5 quart (4.7 liter) capacity.

Electrical: 12 volt Group 55, 450 cold cranking amps at 0°F (-18°C), 75 minute reserve capacity at 80°F (27°C). 14 amp alternator with regulator/rectifier. Seat switch, PTO and traction interlock switches. Indicator light when cutting units are running.

Fuel Capacity: 6.5 gallons.

Traction Drive: High torque hydraulic wheel motors. 3-wheel drive; two position selector valve located below seat, push for 3-wheel drive and pull for 2-wheel drive. Oil cooler and shuttle valve provide positive closed-loop cooling.

Hydraulic Oil Capacity/Filter: Remote mounted, 2.3 gallon (8.7 liter) oil reservoir. 25 micron remote mounted spin on filter.

Ground Speed: Infinitely variable speed selection in forward and reverse

Mowing speed: 0–5 mph (0–8 km/h)
 Transport speed: 0–8 mph (0–13 km/h)
 Reverse speed: 0–3 mph (0–4.8 km/h).

Tires/Wheels: Two front traction drive tires, 20 x 10–8 tubeless, 4–ply rating. Rear steering tire and tube; 20 x 8–8, 4–ply rating. Demountable front rims. Recommended tire pressure: 16–20 psi front and rear tires.

Frame: Frame consists of formed steel, welded steel and steel tubing components.

Model 03422: Tricycle vehicle with 2-wheel traction drive and rear wheel steering.

Model 03427: Tricycle vehicle with 3-wheel traction drive and rear wheel steering.

Steering: Pinion and sector gear with solid drag link to rear steer wheel arm.

Brakes: Service braking accomplished through dynamic characteristics of hydrostat. Parking or emergency brake is actuated by ratchet hand lever on the operator's left hand side.

Controls: Foot operated traction pedal and traction pedal stop. Hand operated throttle, ignition switch, reel engagement switch, cold start button reel unit lift lever, parking brake and seat adjustment.

Model 03427 only: 2 position selector valve for 2 or 3-wheel drive selection.

Gauges and Protective Systems: Hour meter, temperature gauge. 4 light warning cluster gauge: oil pressure, water temperature, amps and glow plug. High water temperature shut-down. Electric traction pump de-clutching switch for cold start. Engine pre-heat incorporated into ignition switch

Seat: Adjustable to operator weight, fore and aft, w/removeable fold-up armrests.

Cutting Unit Lift: Hydraulic lift with automatic reel shut off.

Overall Dimensions:

| | |
|--|----------------|
| Wheel tread width: | 54.5" (138 cm) |
| Wheel base: | 55" (140 cm) |
| Width: | 76.5" (194 cm) |
| Transport Width: | |
| RM 2300–D | 72" (183 cm) |
| RM 2600–D | 85" (216 cm) |
| Length: | 98" (249 cm) |
| Height: | 44" (112 cm) |
| Weight: | |
| Model 03422 – 2wd w/o cutting units. | 1066 lb. |
| Model 03427 – 3wd w/o cutting units. | 1096 lb. |
| Model 03461 27" – 5 bld. cutting unit. | 136 lb. |
| Model 03462 27" – 8 bld. cutting unit. | 143 lb. |
| Model 03466 32" – 5 bld. cutting unit. | 158 lb. |
| Model 03467 32" – 8 bld. cutting unit. | 167 lb. |

Optional Equipment:

| | |
|---|------------------|
| Cushion Seat | Model 30796 |
| Deluxe Suspension Seat | Model 30797 |
| Armrest Kit | Model 30707 |
| Seat Weight Kit (for Seat Model 30796 only) | |
| | Part No. 80–4210 |
| 3 WD Rear Weight Kit | Part No. 94–3663 |
| Rear Weight Kit | Part No. 83–9370 |
| Rear Weight | Part No. 83–9390 |
| CE Compliance Kit | Part No. 93–6945 |

RM 2300–D Optional Equipment:

| | |
|---------------------------|------------------|
| 5 Blade Cutting Unit | Model 03461 |
| 8 Blade Cutting Unit | Model 03462 |
| 2 WD Weight Kit (Baskets) | Part No. 94–5974 |

RM 2600–D Optional Equipment:

| | |
|----------------------|-------------|
| 5 Blade Cutting Unit | Model 03466 |
| 8 Blade Cutting Unit | Model 03467 |

LOOSE PARTS CHART

Note: Use this chart as a checklist to assure all parts necessary for assembly have been received. Without these parts, total set-up cannot be completed. Some parts may have already been assembled at factory.

| | | |
|------------------------------|---|---|
| Wheel Assy | 1 | Install rear wheel on model 03422 |
| Flat washers | 2 | |
| Castor Axle | 1 | |
| Locknut | 1 | |
| Wheel Assy. | 1 | Install rear wheel on model 03427 |
| Lug Nuts | 4 | |
| Flat Washer | 3 | Mount carrier frames to cutting Units (supplied with Lift Arm kit) |
| Capscrew | 3 | |
| Locknut | | |
| Lift Arms | 2 | Install front lift arms (supplied with Lift Arm kit) |
| Pivot Rod | 2 | |
| Capscrews—5/16— 18 x 7/8”Lg. | 2 | |
| Lockwashers | 2 | |
| Lift Chains | 2 | |
| Clevis Pin | 4 | |
| Cotter Pin | 4 | |
| Thrust Washers | 3 | Mount cutting units to lift arms (supplied with Lift Arm kit) |
| Flat Washer | 3 | |
| Flange Head Capscrew | 3 | |
| Spring | 3 | Install counterbalance springs (supplied with Lift Arm kit) |
| Vinyl Sleeve | 1 | |
| Spring Shackle | 3 | |
| Clevis Pin | 6 | |
| Cotter Pin | 6 | |
| Key | 2 | |
| Hydraulic Reservoir Plug | 1 | |
| Operators Manual | 2 | Read before operating machine |
| Parts Catalog | 1 | |
| Registration Card | 1 | Fill out and send to the Toro Co |

Specifications and design subject to change without notice.

SET-UP INSTRUCTIONS

INSTALL REAR WHEEL (Fig. 1 & 2)

Model 03422— Two wheel drive

1. Mount wheel assembly to rear castor fork with (2) flat washers, castor axle and locknut. Washers to be positioned on outside of fork. Torque nut to 45–65 ft–lb.

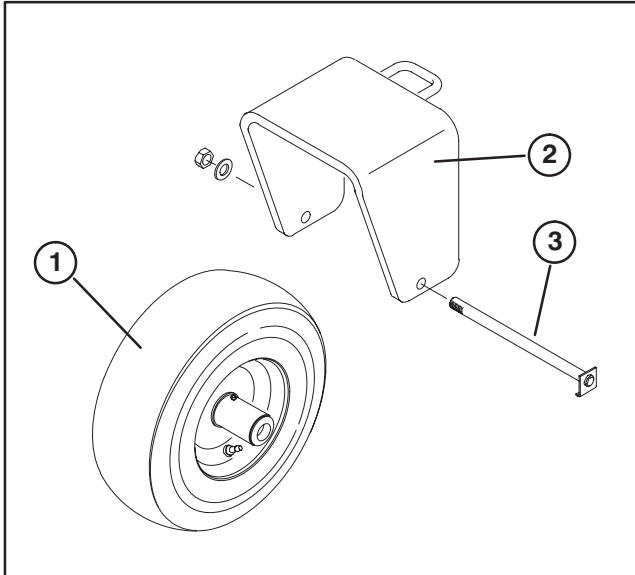

Figure 1

1. Wheel assembly
2. Rear castor fork
3. Castor axle

Model 03427— Three wheel drive

1. Mount wheel assembly onto rear wheel hub.

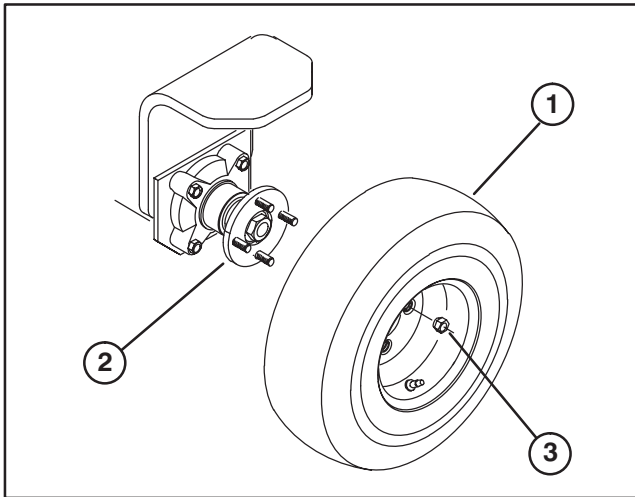

Figure 2

1. Wheel assembly
2. Rear wheel hub
3. Lug nut

2. Install lug nuts and torque to 45–65 ft–lb.

INSTALLING SEAT (Fig. 3)

The Reelmaster is shipped without the seat assembly. Deluxe Seat Kit, Model 30797 or Standard Seat Kit, Model 30796, must be installed as follows:

1. Remove shipping ties securing lower seat slides to upper seat slides. Note orientation of lower slides for correct reinstallation.

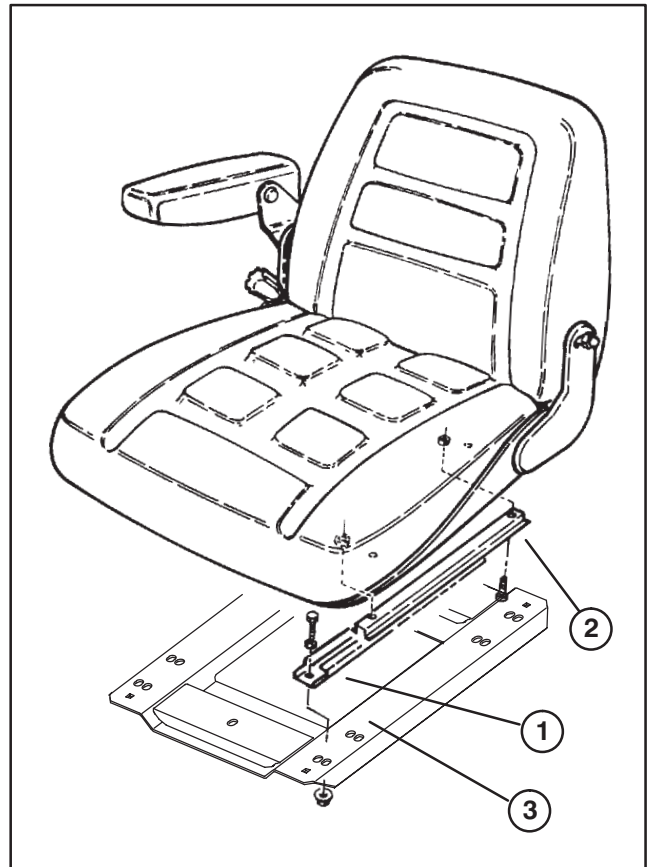

Figure 3

1. Lower seat slide
2. Upper seat slide
3. Seat plate

2. Insert lower slides onto upper slides.

3. On Deluxe Seat, check alignment of mounting holes with seat plate. If holes don't align, remove machine screws securing upper slides to seat bottom. Move seat slides inward to next set of mounting holes and re-secure with machine screws and (4) M8 locknuts. Apply Loctite to fasteners.

4. Loosely secure slides to seat plate with fasteners supplied with seat.

Note: Mount seat in forward holes to attain forward adjustment.

5. Tighten flange nuts and check operation of seat.

Note: For operators that are lightweight, (less than 150 pounds) and short in stature (less than 5'4" tall), an optional weight kit (Toro part no. 80–4210) for seat model 30796 is available from your Authorized Toro Distributor.

SET-UP INSTRUCTIONS

ADJUST REAR CARRIER FRAME HEIGHT (Fig. 4)

1. Slide rear carrier frame onto rear lift arm pivot rod. **Do not install carrier frame to cutting unit at this time.**
2. Raise lift arms and carrier frame fully.

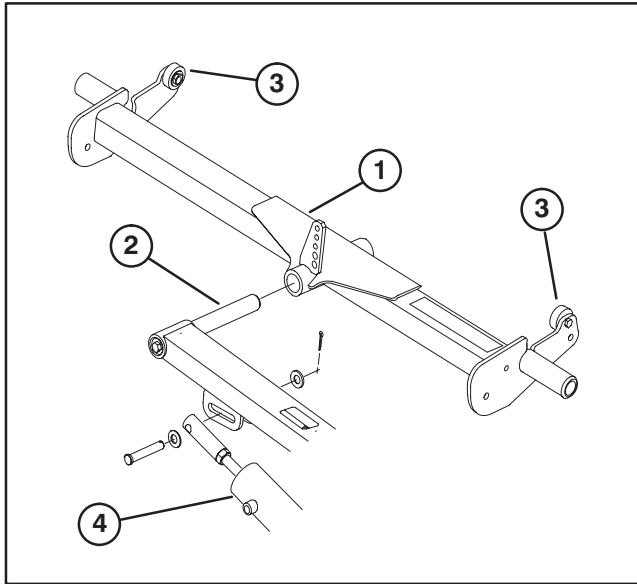

Figure 4

- | | |
|-----------------------|------------------|
| 1. Rear carrier frame | 3. Up stop |
| 2. Pivot rod | 4. Lift cylinder |

3. Press down on one end of carrier frame until up stop on opposite end contacts underside of foot step.
4. Distance between up stop and underside of foot step, on end pressed down, should be approximately .25". If distance is not .25", an adjustment to the lift cylinder is required. If distance is correct, remove carrier frame and proceed with set-up instructions.
5. If an adjustment to lift cylinder is required proceed as follows:
 - A. Remove clevis pin securing rod end of lift cylinder to lift arm.
 - B. Loosen hex nut securing clevis to cylinder rod.
 - C. Rotate clevis end in or out until .25" clearance is attained. Check adjustment and repeat steps 2-4 as required.
 - D. Tighten hex nut and re-connect cylinder rod end to lift arm.

MOUNT CARRIER FRAMES TO CUTTING UNITS (Fig. 5)

1. Remove cutting units from cartons. Adjust per Cutting Unit Operator's Manual.
2. Position a carrier frame onto each cutting unit, aligning mounting holes with mounting links.

3. Secure each mounting link to carrier frame with a 3/8-16 x 2-1/4" lg capscrew, (2) flatwashers and a locknut, as shown in figure 5. Position a washer on each side of link when mounting. Torque to 31 ft-lb.

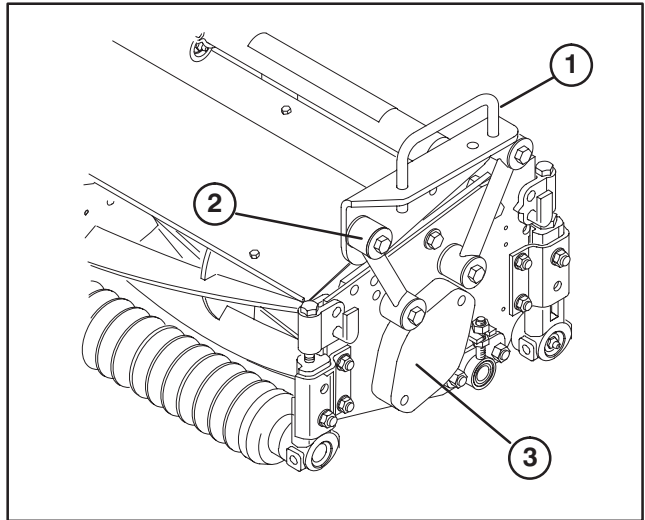

Figure 5

- | |
|--------------------------|
| 1. Carrier frame |
| 2. Mounting link |
| 3. Bearing housing cover |

INSTALL FRONT LIFT ARMS (Fig. 6 - 8)

1. Insert a pivot rod into left lift arm and align mounting holes (Fig. 6).
2. Secure pivot rod to lift arm with a 5/16 - 18 x 7/8" lg. capscrew and lockwasher.

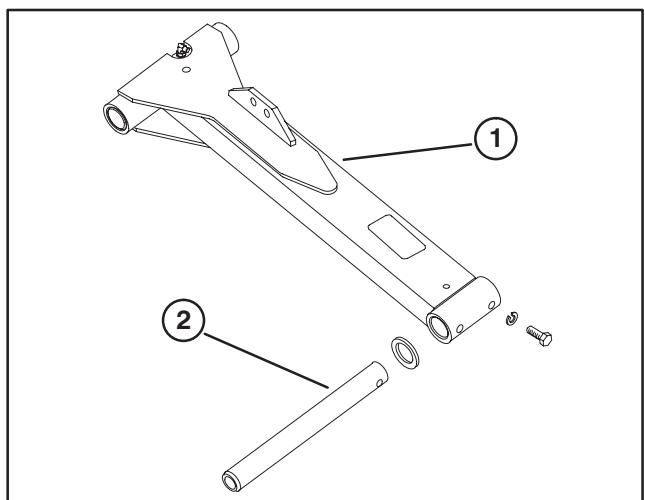

Figure 6

- | |
|--------------|
| 1. Lift arm |
| 2. Pivot rod |

3. Loosen top capscrew securing left counterbalance arm to frame (Fig. 7).
4. Remove bottom capscrew and nut securing left counterbalance arm to frame.
5. Rotate counterbalance arm outward allowing removal of lift arm pivot pin and tipper chain (Fig. 7).

SET-UP INSTRUCTIONS

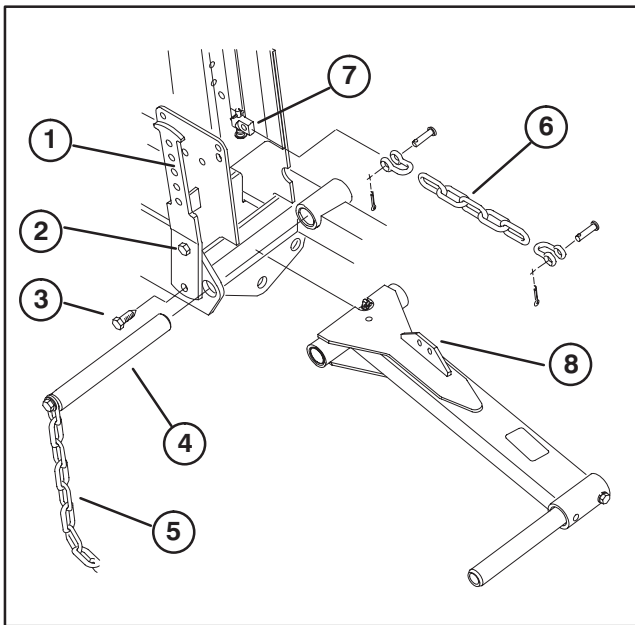

Figure 7

- | | |
|-----------------------|-----------------|
| 1. Counterbalance arm | 5. Tipper chain |
| 2. Top cap screw | 6. Lift chain |
| 3. Bottom cap screw | 7. Cylinder pin |
| 4. Lift arm pivot pin | 8. Lift arm tab |

6. Position lift arm between frame members, align mounting holes and re-install pivot pin (Fig. 7). Pivot pin must be inserted so counterbalance arm fits into slot in pin. Do not secure counterbalance arm at this time.

7. Secure one end of lift chain to lift cylinder pin with a clevis pin and cotter pin.

8. Secure other one end of lift chain to hole in lift arm mounting tab with clevis pins and cotter pins. Use appropriate hole in lift arm as designated in figure 8.

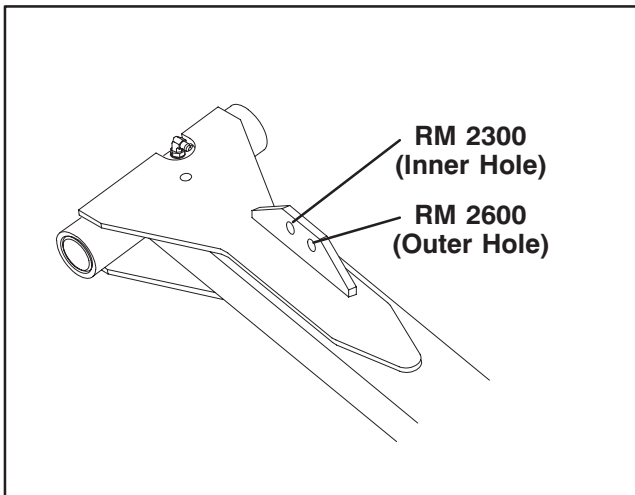

Figure 8

9. Repeat procedure on R.H. lift arm.

MOUNT CUTTING UNIT DRIVE MOTORS

(Fig. 9)

1. Position cutting units in front of pivot rods.
2. Remove bearing housing cover (Fig. 5) from inside end of right hand cutting unit. Install cover and gasket (supplied with cutting unit) on outside end. Locate spider coupling (Fig. 9) shipped in bearing housing.
3. Insert O-ring (supplied with cutting unit) on flange of drive motor.
4. Mount the motor and the spider coupling to the drive end of the cutting unit and secure with two capscrews provided with cutting unit.
5. On center and left hand cutting units, remove bearing housing cover and install gasket (supplied with cutting units).

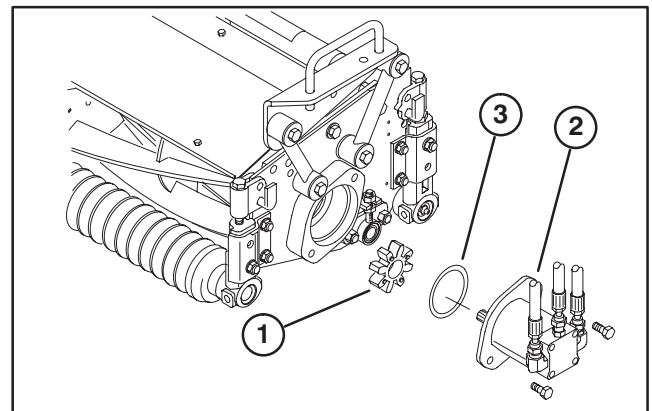

Figure 9

1. Spider coupling
2. Reel motor
3. O-ring

MOUNT CUTTING UNITS (Fig. 10–11)

1. Slide a thrust washer onto lift arm pivot rod.
2. Slide cutting unit carrier frame onto pivot rod and secure with a flatwasher and flange head capscrew (Fig. 10).

Note: On rear cutting unit, thrust washer to be positioned between rear of carrier frame and flatwasher.

SET-UP INSTRUCTIONS

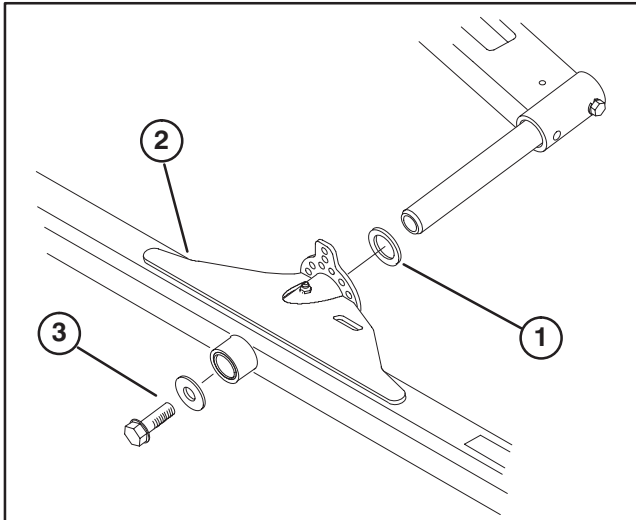

Figure 10

1. Thrust washer
2. Carrier frame
3. Flatwasher and flange head capscrew

3. Secure a tipper chain to top of each Reelmaster 2300 carrier frame and to the bottom of each Reelmaster 2600 carrier frame with a capscrew, washer and locknut (Fig. 11).

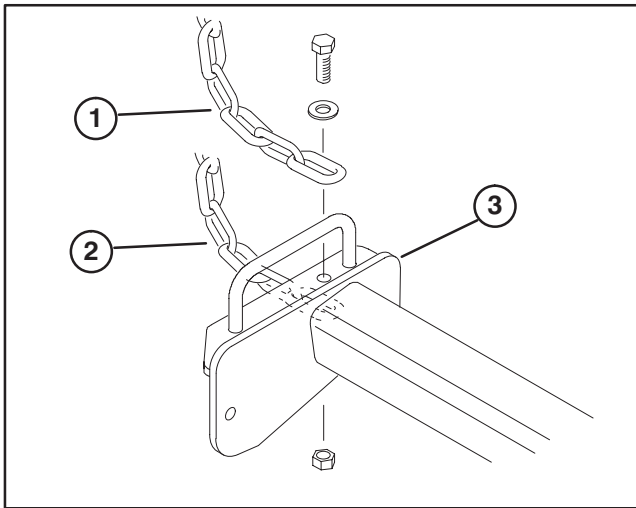

Figure 11

1. Tipper chain (RM 2300)
2. Tipper chain (RM 2600)
3. Carrier frame

4. Grease all lift arm and carrier frame pivot points.



WARNING

Use caution when tensioning springs as they are under heavy load.

INSTALL COUNTERBALANCE SPRINGS

(Fig. 12)

1. Hook one end of spring into third hole from top on inboard side of front cutting unit lift tab and top hole on rear cutting unit lift tab (Fig. 12).

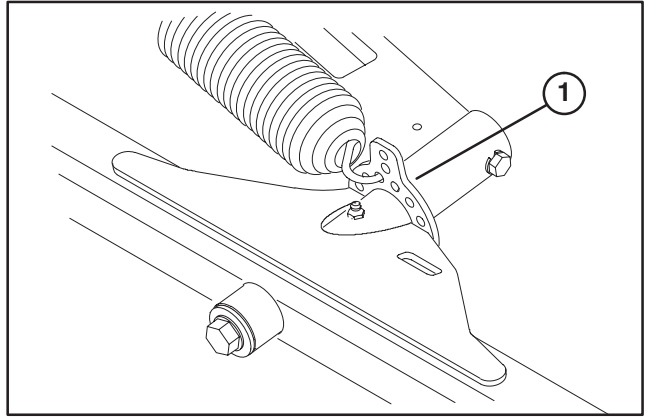

Figure 12

1. Cutting unit lift tab

2. Secure other end of spring to appropriate hole (see below) on front counterbalance arm (Fig. 13) with spring shackle, clevis pin and cotter pin.

Note: On Reelmaster 2600D, secure spring to spring shackle with chain, clevis, clevis pin and cotter pin (Fig. 13, inset).

- A. Middle hole — for 5 blade reel application
- B. Second hole from top — for 8 blade reels without baskets
- C. Top hole — for 8 blade reels with baskets

Note: On rear counterbalance spring, install vinyl cover over spring before installing. Also, hook end of spring in on hole higher than front except for 8 blade reels with baskets.

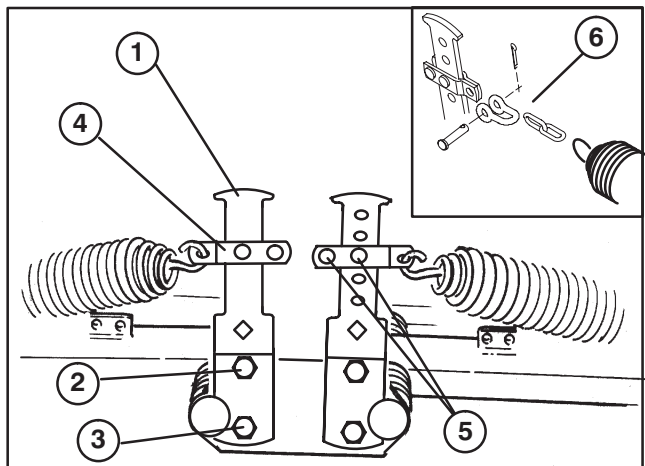

Figure 13

1. Counterbalance arm
2. Top capscrew
3. Bottom capscrew
4. Spring shackle
5. Clevis pin & cotter pin
6. Chain, clevis & clevis pin (Reelmaster 2600D only)

IMPORTANT: These are recommended settings. Readjust spring positions to attain optimum performance. By raising spring locations on counterbalance arms, cutting unit weight on ground is reduced and traction is increased.

SET-UP INSTRUCTIONS

3. Insert breaker bar into square hole in counterbalance arm and pivot arm back to original position aligning mounting holes.

4. Secure bottom of counterbalance arm to frame with capscrew and nut previously removed. Tighten top capscrew.

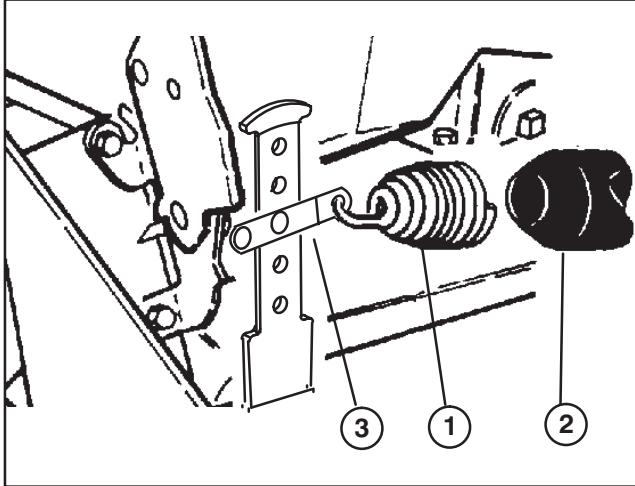

Figure 14

1. Rear counter balance spring
2. Vinyl cover
3. Spring shackle

5. To tension the counterbalance springs proceed as follows:

A. Remove cotter pin and clevis pin securing spring shackle to counterbalance arm. Do not remove other clevis pin.

B. Move shackle up or down on counterbalance arm, until aligned with desired hole of arm. Reinstall clevis pin and cotter pin.

ADD REAR BALLAST

This unit complies with ANSI B71.4–1984 Standard and all applicable European requirements when equipped with rear ballast. Use the following chart to determine weight or combinations of weights needed.

| Cutting Unit Configuration | Weight Kits Required |
|-----------------------------|--|
| RM 2300D – 2WD | (1) 83–9370 & (1) 83–9390 |
| RM 2300D – 2WD with Baskets | (1) 83–9370, (1) 83–9390 & (1) 94–5974 |
| RM 2300D – 3WD | (1) 83–9390 & (1) 94–3663 |
| RM 2300D – 3WD with Baskets | (2) 83–9390 & (1) 94–3663 |
| RM 2600D – 2WD | (2) 83–9390 & (1) 94–3663 |
| RM 2600D – 3WD | (1) 83–9370 & (1) 83–9390 |

Note: All configurations require calcium chloride in the rear tire. Tires should be filled to approximately 75% capacity (valve level with valve at the top) (60 lbs. fluid or 74 lbs. tire and fluid).

IMPORTANT: If a puncture occurs in a tire with calcium chloride, remove unit from turf area as quickly as possible. To prevent possible damage to turf, immediately soak affected area with water.

Either Type 1 (77%) or Type 2 (94%) commercial calcium chloride flake may be used.

Plain water freezes solid at 32°F (0°C). The 3–1/2 pound (1.6 kg) calcium chloride to one gallon (3.8 L) of water solution is slush free to –12°F (–24°C), and will freeze solid at –52°F (–46°C). The 5 pound (2.3 kg) per gallon (liter) solution is slush free to –50°F (–45°C) and will freeze solid at –62°F (–52°C).

AFFIX DECALS (Fig. 15)

1. Using dimensions shown in figure 15, locate and affix a Reelmaster 2300 or 2600 decal to skirt on each side of machine.

Note: To ease installation of decal use the following procedure:

- In a spray bottle, mix 1 ounce liquid soap and 20 ounces of water.
- Spray skirt panel with soap solution, peel backing off decal, position decal on skirt and adjust as necessary.
- Run plastic squeegee over decal to remove excess soap solution.
- Peel front cover paper off decal.

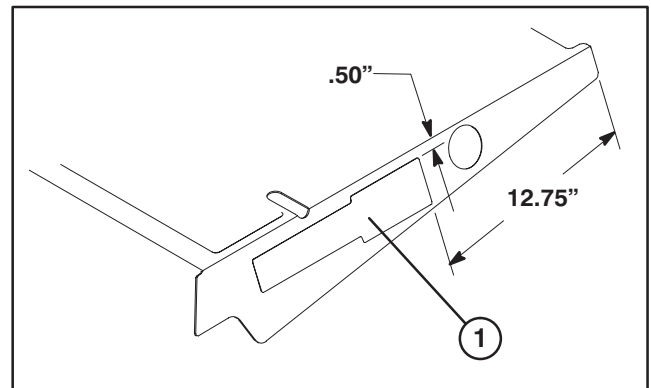

Figure 15

1. Decal

ACTIVATE AND CHARGE BATTERY (Fig. 16)

(Fig. 16)

1. If Battery is not filled with electrolyte or activated, bulk electrolyte with 1.260 specific gravity must be purchased from a local battery supply outlet and added to battery.

2. Remove filler caps from battery and slowly fill each cell until electrolyte is just above the plates.

SET-UP INSTRUCTIONS

3. Replace filler caps with vents pointing to the rear (toward fuel tank) and connect a 3 to 4 amp battery charger to the battery posts. Charge the battery at a rate of 3 to 4 amperes for 4 to 8 hours.

4. When battery is charged, disconnect charger from electrical outlet and battery posts.

5. Remove filler caps. Slowly add electrolyte to each cell until level is up to fill ring. Install filler caps.



CAUTION

Wear safety goggles and rubber gloves when working with electrolyte. Charge the battery in a well ventilated place so gasses produced while charging can dissipate. Since the gases are explosive, keep open flames and electrical spark away from the battery; do not smoke. Nausea may result if the gases are inhaled. Unplug charger from electrical outlet before connecting to or disconnecting charger leads from battery posts.

IMPORTANT: Do not overfill battery. Electrolyte will overflow onto other parts of the machine and severe corrosion and deterioration will result.

6. Install the positive cable (red) to the positive (+) terminal and the negative cable (black) to the negative (—) terminal of the battery and secure with capscrews and nuts. Slide the rubber boot over the positive terminal to prevent possible short-out from occurring.

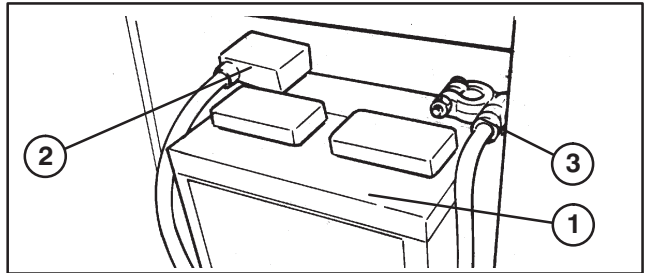

Figure 16

1. Battery
2. Positive (+) battery cable
3. Negative (—) battery cable

BEFORE OPERATING

**CAUTION**

Before servicing or making adjustments to the machine, stop engine and remove key from the switch.

CHECK CRANKCASE OIL (Fig. 17–18)

The engine is shipped with oil in the crankcase; however, level of oil must be checked before and after the engine is first started.

Crankcase capacity is approximately 3 qts. (2.8 l) with filter.

1. Position machine on a level surface.
2. Remove dipstick and wipe it with a clean rag. Push dipstick down into dipstick tube and make sure it is seated fully. Pull dipstick out and check level of oil. If oil level is low, add enough oil to raise level to FULL mark on dipstick.
3. If oil level is low, remove oil fill cap (Fig. 18) and gradually add small quantities of oil, checking level frequently, until level reaches FULL mark on dipstick.
4. The engine uses any high-quality 10W30 detergent oil having the American Petroleum Institute – API – “service classification” CD.

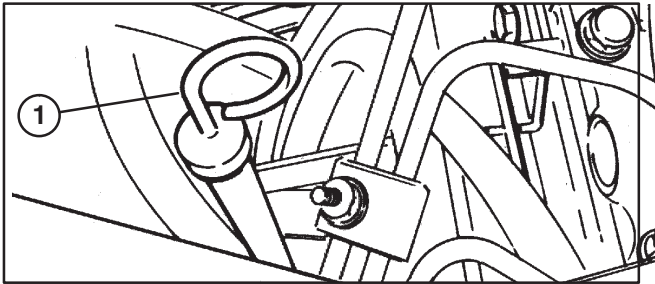

Figure 17
1. Dipstick

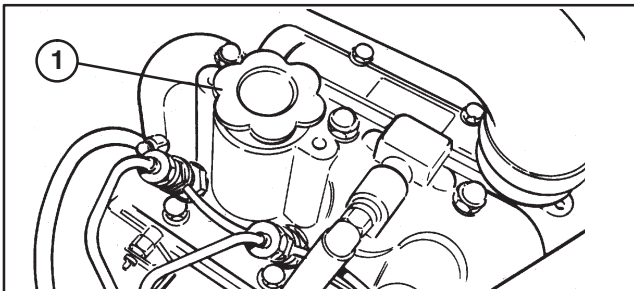

Figure 18
1. Oil fill cap

IMPORTANT: Check level of oil every 5 operating hours or daily. Change oil after every 50 hours of operation.

FILL FUEL TANK (Fig. 19)

The engine runs on No. 2 diesel fuel.

Fuel tank capacity is approximately 6.5 gallons.

1. Clean area around fuel tank cap.

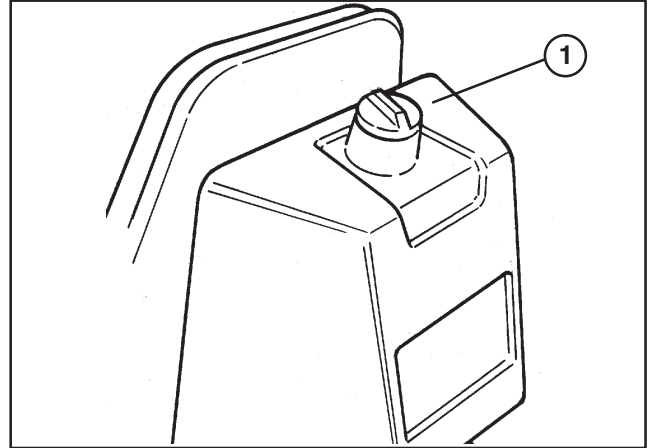



Figure 19
1. Fuel tank cap

2. Remove fuel tank cap.

**DANGER**

Because diesel fuel is flammable, use caution when storing or handling it. Do not smoke while filling the fuel tank. Do not fill fuel tank while engine is running, hot, or when machine is in an enclosed area. Always fill fuel tank outside and wipe up any spilled diesel fuel before starting the engine. Store fuel in a clean, safety-approved container and keep cap in place. Use diesel fuel for the engine only; not for any other purpose.

3. Fill tank to about one inch below top of tank, (bottom of filler neck). **DO NOT OVERFILL.** Then install cap.
4. Wipe up any fuel that may have spilled to prevent a fire hazard.

CHECK COOLING SYSTEM (Fig. 20 & 21)

Clean debris off radiator screen, radiator and oil cooler daily (Fig. 20), hourly if conditions are extremely dusty and dirty; refer to Cleaning Radiator and Screen Section.

1. The cooling system is filled with a 50/50 solution of water and permanent ethylene glycol anti-freeze. Check level of coolant at beginning of each day before starting the engine. Capacity of cooling system is approximately 5–1/4 quarts.

BEFORE OPERATING

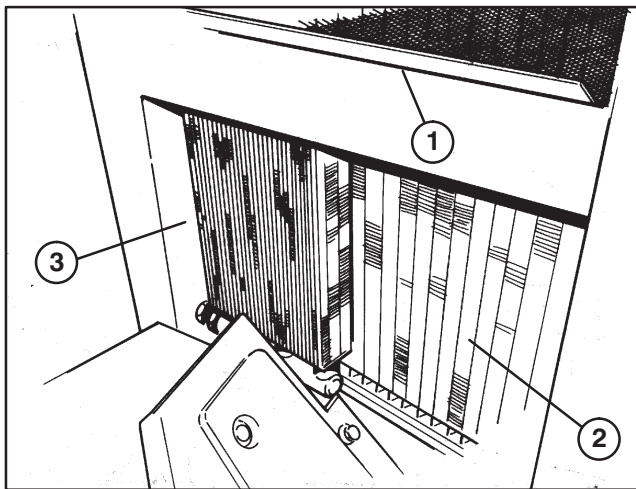



Figure 20

1. Radiator screen
2. Radiator
3. Oil cooler



CAUTION

If engine has been running, pressurized hot coolant can escape when radiator cap is removed and cause burns. Only open radiator cap when engine is cold.

1. Carefully remove cap from radiator.

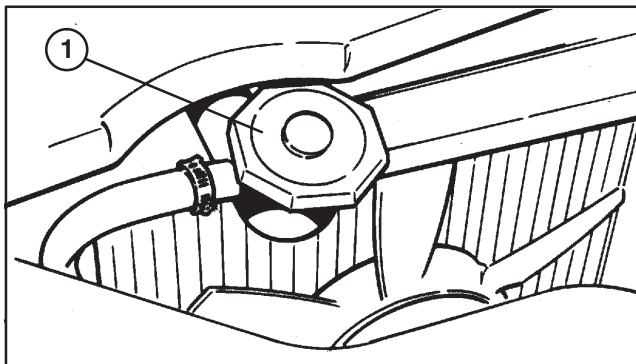

Figure 21

1. Radiator cap

2. Check level of coolant in radiator. Radiator should be filled to the middle of horizontal filler neck.
3. If coolant level is low, replenish the system. **DO NOT OVERFILL.**
4. Install radiator cap.

CHECK HYDRAULIC SYSTEM FLUID (Fig. 22)

The hydraulic system is designed to operate on anti-wear hydraulic fluid. The machine's reservoir is filled at the factory with approximately 3.3 gallons of Mobil 424 hydraulic fluid. **Check level of hydraulic fluid before engine is first started and daily thereafter.**

Group 1 Hydraulic Fluid (Recommended for ambient temperatures consistently below 100° F.):

ISO type 46/68 anti-wear hydraulic fluid

| | |
|-------------------------|-------------------------|
| Mobil | Mobil Fluid 424 |
| Amoco | Amoco 1000 |
| International Harvester | Hy-Tran |
| Texaco | TDH |
| Shell | Donax TD |
| Union Oil | Hydraulic/Tractor Fluid |
| Chevron | Tractor Hydraulic Fluid |
| BP Oil | BP HYD TF |
| Boron Oil | Eldoran UTH |
| Exxon | Torque Fluid |
| Conoco | Power-Tran 3 |
| Kendall | Hyken 052 |
| Phillips | HG Fluid |

Note: The fluids within this group are interchangeable.

Group 2 Hydraulic Fluid (Biodegradable):

ISO VG 32/46 anti-wear hydraulic fluid

| | |
|-------|-----------|
| Mobil | EAL 224 H |
|-------|-----------|

IMPORTANT: Due to the nature of biodegradable fluids, it is critical that the fluid be changed at the recommended intervals or severe hydraulic component damage may occur.

Note: The fluid in this group is not compatible with the fluids in group 1.

IMPORTANT: These hydraulic fluids are specified to allow optimal operation of the machine in a wide range of temperatures encountered. The group 1 fluids are a multi-viscosity hydraulic fluids which allows operation at lower temperatures without the increased viscosity, which is associated with straight viscosity fluids.

NOTE: When changing from one type of hydraulic fluid to the other, be certain to remove all the old fluid from the system, because some brands of one type are not completely compatible with some brands of the other type of hydraulic fluid.

IMPORTANT: Use only types of hydraulic fluids specified. Other fluids could cause system damage.

Note: A red dye additive for the hydraulic system fluid is available in 2/3 oz bottles. One bottle is sufficient for 4–6 gal of hydraulic fluid. Order Part No. 44–2500 from your Authorized Toro Distributor.

1. Position machine on a level surface.
2. Check level of fluid by viewing in sight gauge. If fluid is cold, level should be at bottom of gauge. If fluid is hot, level should be at center of gauge.

BEFORE OPERATING

3. If fluid level is not at least at bottom of gauge when cold, remove cap from hydraulic fluid reservoir and slowly fill reservoir with Mobil 424 or equivalent hydraulic fluid until level in reaches bottom of sight gauge. **DO NOT OVERFILL.**

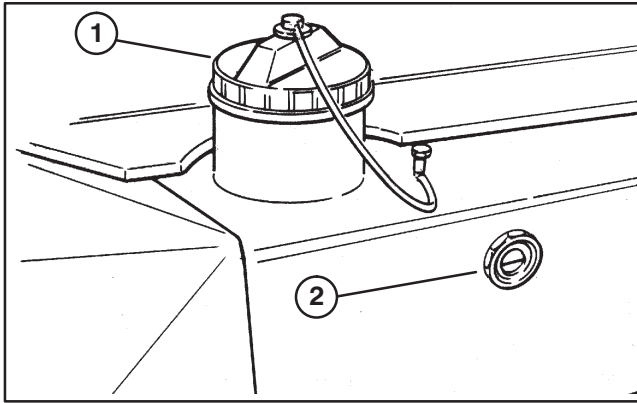

Figure 22

1. Hydraulic reservoir cap
2. Sight Gauge

IMPORTANT: To prevent system contamination, clean top of hydraulic fluid containers before puncturing. Assure pour spout and funnel are clean.

4. Install reservoir cap. Wipe up any fluid that may have spilled.

INSPECT FUEL FILTER (Fig. 23)

Inspect fuel filter bowl, daily, for water or other contaminants. If water or other contaminants are present, they must be removed before commencing operation.

1. Close fuel shut-off above filter.
2. Unscrew nut securing bowl to filter head. Remove water or other contaminants from bowl.

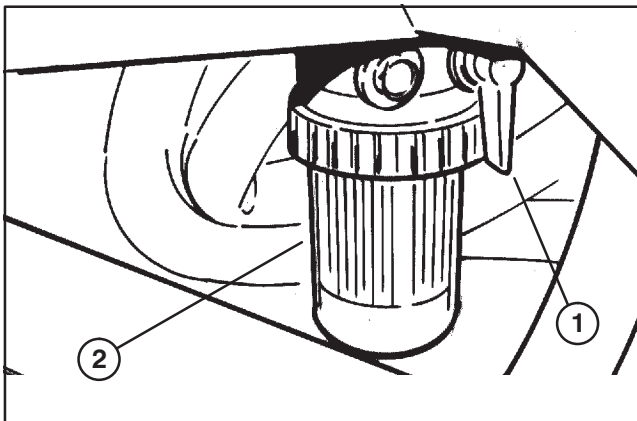

Figure 23

1. Fuel shut-off
2. Fuel filter

3. Inspect fuel filter and replace if dirty. Refer to Replacing Fuel Filter.



DANGER

Because diesel fuel is flammable, use caution when storing or handling it. Do not smoke while filling the fuel tank. Do not fill fuel tank while engine is running, hot, or when machine is in an enclosed area. Always fill fuel tank outside and wipe up any spilled diesel fuel before starting the engine. Store fuel in a clean, safety-approved container and keep cap in place. Use diesel fuel for the engine only; not for any other purpose.

4. Re-install bowl to filter head. Make sure O-ring is positioned properly between bowl mounting nut and filter head.

5. Open fuel shut-off above filter.

6. Open bleed screw on filter mounting allowing bowl to re-fill with fuel. Close bleed screw.

CHECK TIRE PRESSURE

The tires are over-inflated for shipping. Therefore, release some of the air to reduce the pressure. Correct air pressure in tires is 16–20 psi.

IMPORTANT: Maintain recommended pressure in all tires to assure a good quality-of-cut and proper machine performance. **DO NOT UNDER INFLATE.**

CHECK REEL TO BEDKNIFE CONTACT

Each day before operating, check reel to bedknife contact, regardless if quality of cut had previously been acceptable. There must be light contact across the full length of the reel and bedknife (refer to Adjusting Reel to Bedknife in Cutting Unit Operator's Manual).

CHECK TORQUE OF WHEEL NUTS



WARNING

Torque wheel nuts to 45-65 ft-lb after 1-4 hours of operation and again after 10 hours of operation and every 200 hours thereafter. Failure to maintain proper torque could result in failure or loss of wheel and may result in personal injury.

CONTROLS

Traction and Stopping Pedal (Fig. 24 & 25) — Traction pedal has three functions: one, to make the machine move forward, two, to move it backward and three, to stop machine. Using the heel and toe of the right foot, depress top of pedal to move forward and bottom of pedal to move backward or to assist in stopping when moving forward. Also, allow pedal to move or move it to neutral position to stop machine. For operator comfort, do not rest heel of foot on reverse when operating forward.

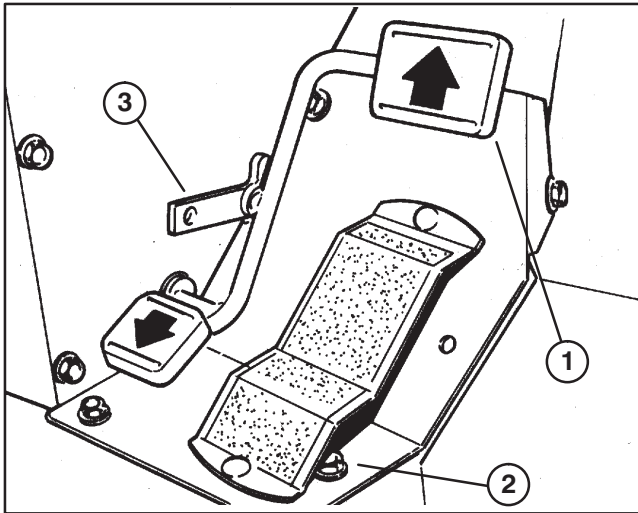

Figure 24

1. Traction pedal
2. Speed selector
3. Pedal stop

Speed Selector (Fig. 30) — Cam lever at side of traction pedal can be rotated to maintain desired speed.

The reverse pedal stop (under pedal) is set at the factory to provide 3 M.P.H. maximum speed in the reverse direction.

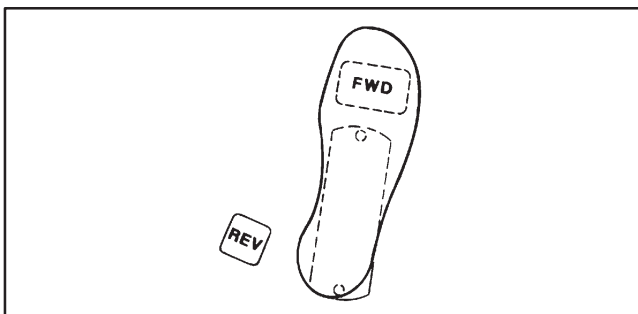

Figure 25

Starter Switch (Fig. 26) — The starter switch, used to start, stop and preheat the engine, has four positions: OFF, ON, START and GLOW PLUGS (PREHEAT). Rotate key counterclockwise — GLOW PLUG position — and hold for approximately 20 to 30 seconds, then rotate key clockwise — START position — to engage starter motor. Release key when engine starts. The key will move automatically to the ON/RUN position. To shut engine off, rotate key counterclockwise to OFF

position. Remove key from switch and install switch cover to prevent accidental starting.

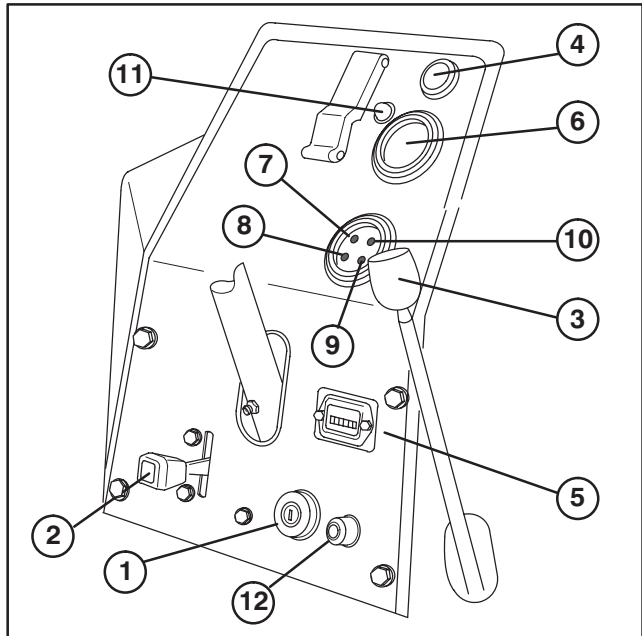

Figure 26

- | | |
|------------------------------|--|
| 1. Starter switch & cover | 8. Alternator light |
| 2. Throttle | 9. Glow plug indicator light |
| 3. Cutting unit lift lever | 10. High water temperature shut-down light |
| 4. Cutting unit drive switch | 11. Reel operating light |
| 5. Hour meter | 12. Cold start button |
| 6. Water temperature gauge | |
| 7. Oil pressure light | |

Throttle (Fig. 26) — Moving throttle upward increases engine speed, downward decreases engine speed.

Cutting Unit Lift Lever (Fig. 26) The lift lever has three positions: LOWER, RAISE, and NEUTRAL. To lower cutting units to the ground, move lift lever forward. When lowering cutting units, make sure front hydraulic cylinder is completely retracted before releasing lift lever. Cutting units will not operate unless cylinder is retracted. To raise cutting units, pull lift lever rearward to the RAISE position. To decrease play in lever, tighten retaining locknut.

Cutting Unit Drive Switch (Fig. 26) — The switch has two positions: ENGAGE and DISENGAGE. Push—Pull switch operates a solenoid valve, on valve bank, to drive cutting units. Yellow light on dash indicate when reels are rotating.

Hour Meter (Fig. 26) — Indicates the total hours of machine operation. The Hour Meter starts to function whenever the key switch is rotated to “ON” position.

Temperature Gauge (Fig. 26) — Registers coolant temperature in system.

Oil Pressure Light (Fig. 26) — Light glows if engine oil pressure drops below a safe level.

Water Temperature Light (Fig. 26) — Light glows and engine automatically shuts-down when engine coolant temperature gets too high.

CONTROLS

Alternator Light (Fig. 26) — The amp light should be off when engine is running. If it is on, the charging system should be checked and repaired as necessary.

Glow Plug Indicator (Fig. 26) — Indicator light will glow when glow plugs are operating.

Cold Start Button (Fig. 26) —When starting a cold engine, press cold start button to electrically de-clutch traction pump. When engine starts release button.

Parking Brake — Whenever the engine is shut off, the parking brake must be engaged to prevent accidental movement of the machine. To engage the parking brake, pull back on lever.

Drive Engagement Control —Model 03426 only— (Fig. 27) — On lower left side of operator. Pull knob out for 2 wheel drive; push knob in for 3 wheel drive.

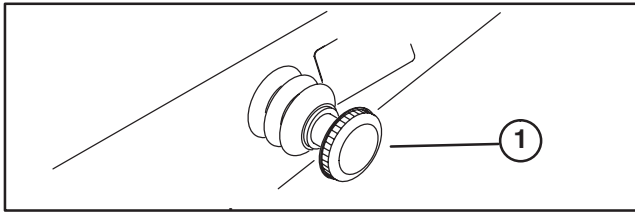

Figure 27

1. Drive engagement control
Pull out — Two wheel drive
Push in — Three wheel drive

Reel Speed Control — (Fig. 28) — To obtain the desired clip rate (reel speed), rotate reel speed control knob to appropriate setting for height-of-cut setting and mower speed. Refer to Selecting Clip Rate section of Manual.

Backlap Control — (Fig. 28) — Rotate knob clockwise for backlapping and counterclockwise for mowing. Do not change knob position when reels are rotating.

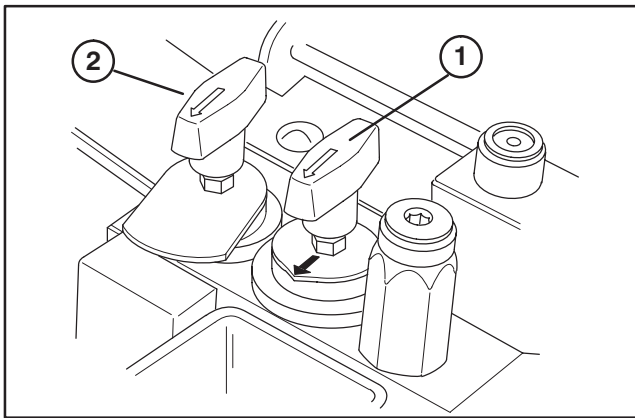

Figure 28

1. Reel speed control
2. Backlap control

Seat Adjustments (Fig. 29)

Fore and Aft Adjustment — Move lever on side of seat outward, slide seat to desired position and release lever to lock seat into position.

Deluxe Seat Adjustments (Fig. 29)

Weight Adjustment — Push lever up or down to adjust to operator's weight. Lever up — light operator, lever in middle position — medium weight operator or lever down for heavy operator.

Inclining Backrest — Turn handle to adjust angle of backrest. (Deluxe Seat only).

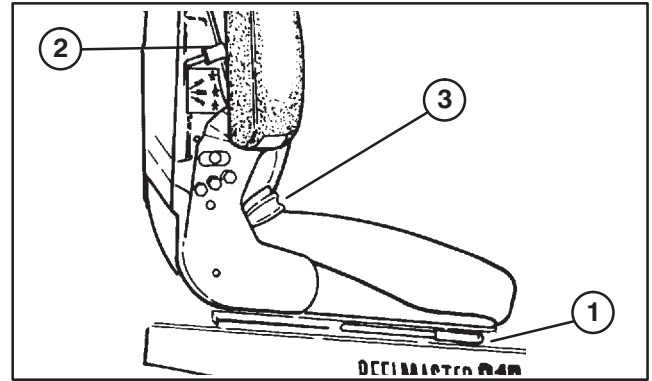

Figure 29

1. Fore and aft lever
2. Weight adjustment lever
3. Inclining backrest

Fuel Shut-off Valves (Fig. 30 & 31) — Close fuel shut-off valves, under fuel tank and on fuel filter, when storing machine.

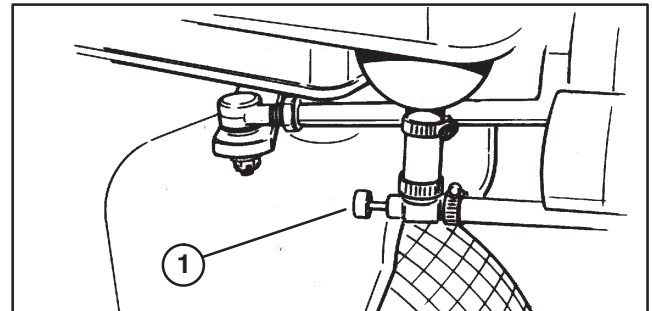

Figure 30

1. Fuel shut off (under fuel tank)

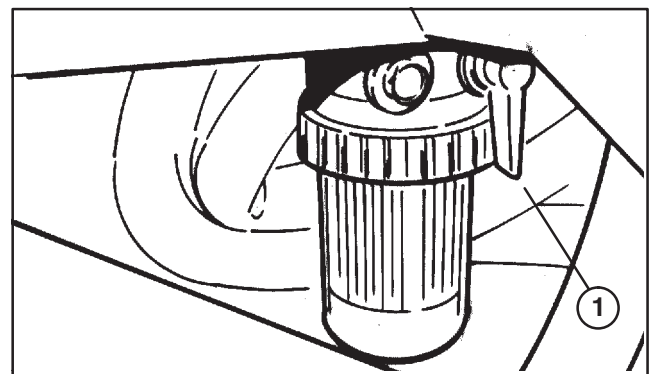

Figure 31

1. Fuel shut off (on fuel filter)

OPERATING INSTRUCTIONS

STARTING/STOPPING ENGINE

IMPORTANT: The fuel system may have to be bled if any of the following situations have occurred:

- A. Initial start up of a new engine.
- B. Engine has ceased running due to lack of fuel.
- C. Maintenance has been performed upon fuel system components; i.e. filter replaced, etc.

Refer to Bleeding Fuel System

1. Be sure parking brake is set and Reel Drive switch is in DISENGAGE position.
2. Remove foot from traction pedal and make sure pedal is in neutral position.
3. Move throttle lever to full throttle position.
4. Remove cover from starter switch. Insert key into switch and rotate it counterclockwise — GLOW PLUG position — and hold for approximately 20 to 30 seconds, then rotate key clockwise — START position — to engage starter motor. Release key when engine starts. The key will move automatically to the ON/RUN position.

IMPORTANT: To prevent overheating of the starter motor, do not engage starter longer than 10 seconds. After 10 seconds of continuous cranking, wait 60 seconds before engaging starter motor again.

5. For cold weather starting, press cold start button to de-clutch electric traction pump. When engine starts release button.
6. When engine is started for the first time, or after overhaul of the engine, operate the machine in forward and reverse for one to two minutes. Also operate the lift lever and reel drive switch to be sure of proper operation of all parts.

Turn steering wheel to the left and right to check steering response. Then shut engine off and check for oil leaks, loose parts and any other noticeable malfunctions.



CAUTION

Shut engine off and wait for all moving parts to stop before checking for oil leaks, loose parts and other malfunctions.

7. To stop engine, move throttle control downward to IDLE position, move reel drive switch to DISENGAGE and rotate starter key to OFF. Remove key from switch and install switch cover to prevent accidental starting.
8. Close fuel shut off valves before storing machine.

BLEEDING FUEL SYSTEM (Fig. 32–33)

1. Park the machine on a level surface. Make sure fuel tank is at least half full.
2. Unlatch and raise hood.



DANGER

Because diesel fuel is flammable, use caution when storing or handling it. Do not smoke while filling the fuel tank. Do not fill fuel tank while engine is running, hot, or when machine is in an enclosed area. Always fill fuel tank outside and wipe up any spilled diesel fuel before starting the engine. Store fuel in a clean, safety-approved container and keep cap in place. Use diesel fuel for the engine only; not for any other purpose.

3. Open fuel shut-off valve under fuel tank and on fuel filter.
4. Open (2) bleed screws, on side of fuel filter mounting head, allowing bowl to re-fill with fuel. Close bleed screws when bowl is filled.

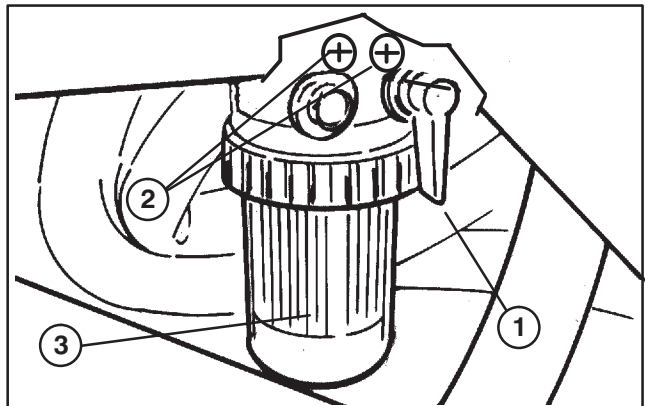

Figure 32

1. Fuel shut off
2. Bleed screws (2)
3. Bowl

5. On front of engine (by oil filter) locate transfer pump inlet screw. Note angle of fitting on transfer pump inlet and loosen screw (left screw only).
6. When a steady stream of fuel flows out of transfer pump screw, tighten screw, retaining angle of fitting before loosening.
7. Loosen injection pump inlet screw on front of engine.
8. Pump priming lever until a steady stream of fuel flows out of injection pump inlet screw, then tighten screw. Do not over-tighten screw as damage may occur.
9. Start engine. If it still doesn't run smoothly after several minutes, crack each injector nut until fuel (no bubbles) comes out.

OPERATING INSTRUCTIONS

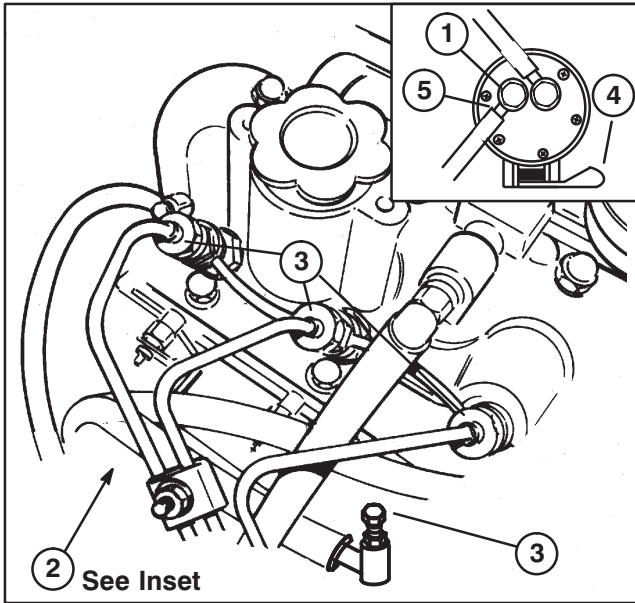

Figure 33

1. Transfer pump screw
2. Transfer pump inlet screw location
3. Injection pump inlet screw
4. Priming lever
5. Note fitting angle
6. Injector nuts

CHECK OPERATION OF INTERLOCK SWITCHES



CAUTION

Do not disconnect the safety switches because they are for the operator's protection. Check operation of the switches daily to be sure the interlock system is operating correctly. If a switch is not operating properly, replace it before operating the machine. Replace the switches every two years to be sure of maximum safety.

1. Be sure parking brake is set and all bystanders are away from the area of operation. Keep hands and feet away from cutting units.
2. With operator off the seat, backlap knob rotated counterclockwise, traction pedal in neutral and reel switch in OFF position, the engine should start. If either the traction pedal is depressed or the reel switch is turned ON, with operator off the seat, the engine should stop. Correct problem if not operating properly.
3. With engine running, operator off the seat and backlap knob rotated clockwise engine should not stop when reel switch is turned ON. Correct problem if not operating properly.
4. With operator on the seat, engine running, and reel switch in ON position, the dash indicator light should be glowing and the reel motors turning when the lift cylinder is fully retracted. As the lift cylinder is

extended, the light should go out and the reel motors stop turning. Correct problem if not operating properly.

5. With operator on seat, the engine must not start with either reel switch engaged or traction control engaged. Correct problem if not operating properly.

TOWING TRACTION UNIT (Fig. 34)

In case of emergency, the Reelmaster can be towed for a short distance. However, Toro does not recommend this as a standard procedure.

IMPORTANT: Do not tow the machine faster than 2–3 mph because drive system may be damaged. If machine must be moved a considerable distance, transport it on a truck or trailer.

1. Locate by-pass valve on pump and rotate it 90° (By-pass valve lever should be horizontal when open).

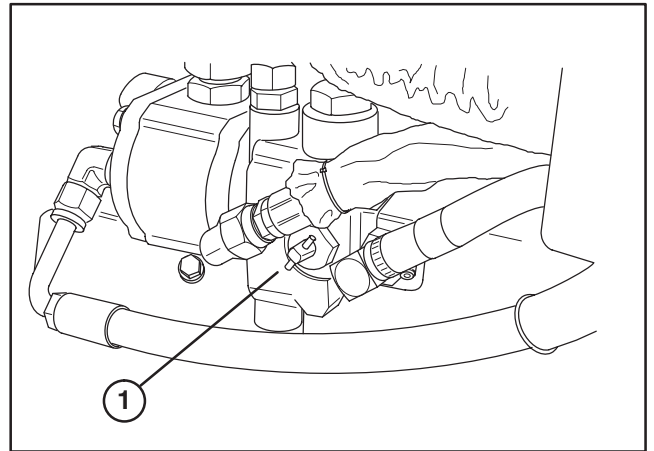

Figure 34

1. By-pass valve

2. Before starting engine, close by-pass valve by rotating it 90° (By-pass valve lever should be vertical when closed). Do not start engine when valve is open.

OPERATING CHARACTERISTICS

CAUTION: This product may exceed noise levels of 85 dB(A) at the operator position. Ear protectors are recommended, for prolonged exposure, to reduce the potential of permanent hearing damage.

Practice operating the Reelmaster and become thoroughly familiar with it. Because of its hydrostatic transmission and choices of two or three wheel drive (model 03427 only), its characteristics differ from many turf maintenance machines. Points to consider when operating are the traction drive, engine speed and load on the cutting units. Regulate the traction pedal to keep engine rpm high and somewhat constant while mowing to maintain adequate power for the traction and cutting units. Adjust the speed selector to maintain constant ground speed and quality of cut. However, when on hilly terrain, do not use the speed selector.

OPERATING INSTRUCTIONS

Follow operating guidelines presented in this manual and know how to operate the machine safely on all types of terrain. Use the slope gauge, page 39, to assist in determining slope angles of questionable areas. Hills (or slopes) over 15 degrees should be traversed or mowed up and down, not side to side and hills over 20 degrees should generally be avoided unless special safeguards, skills and conditions exist. Always plan well ahead to avoid the need for sudden stops, starts or turns. To stop, use the reverse pedal for braking. Before stopping the engine, disengage all controls, move throttle to IDLE position, and set parking brake.

SELECTING CLIP RATE (REEL SPEED)

| HEIGHT OF CUT | 5 BLADE REEL | | | | 8 BLADE REEL | | | | |
|-------------------------------|--------------|-----|-----|-----|---------------------------|-----|-----|-----|---|
| | 3WD | 2WD | 3WD | 2WD | 3WD | 2WD | 3WD | 2WD | |
| 2 1/2" (64mm) - 2 3/8" (60mm) | 3 | 5 | - | 3 | 1 1/2" (32 mm) | 7 | - | 4 | 6 |
| 2 1/4" (57mm) - 2 1/8" (54mm) | 4 | 5 | - | 3 | 1 1/8" (29 mm) | 7 | - | 5 | 7 |
| 2" (51 mm) | 4 | 6 | - | 3 | 1" (25 mm) | 8 | - | 5 | 9 |
| 1 7/8" (48 mm) | 4 | 6 | 3 | 4 | 7/8" (22 mm) | 9 | - | 6 | - |
| 1 3/4" (44mm) - 1 3/8" (41mm) | 5 | 7 | 3 | 4 | 3/4" (19 mm) | - | - | 7 | - |
| 1 1/2" (38mm) - 1 1/8" (35mm) | 6 | - | 4 | 5 | 5/8" (16mm) - 3/8" (10mm) | - | - | 9 | - |

94-5056

To achieve a consistent, high quality of cut, and a uniform after cut appearance, it is important that the reel speed be matched to the height of cut.

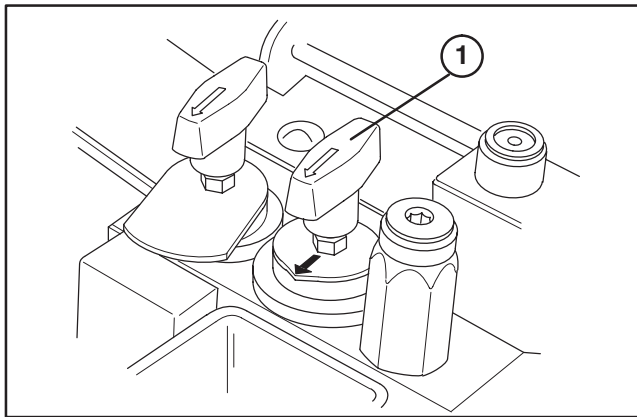

Figure 35
1. Reel speed control

Adjust the clip rate (reel speed) as follows:

1. Verify the height-of-cut setting on the cutting units. Using the column of the chart listing either 5 or 8 blade reels, find the height of cut listing nearest the actual height-of-cut setting. Look across the chart to find the number corresponding to that height of cut.
2. Turn the reel speed control knob to the number setting determined in step 1.
3. Operate the machine for several days, then examine the cut to ensure satisfaction with the quality of cut. The reel speed knob may be set one position on either side of the position indicated on the chart to account for differences in grass condition, grass length removed, and personal preference of the superintendent.

5 BLADE REEL

RM 2300/2600—D VARIABLE REEL SPEED SELECTION CHART

| HEIGHT OF CUT | | 3WD SPEEDS 3–5 MPH | 2WD SPEEDS 6–7 MPH |
|---------------|------|--------------------------|--------------------------|
| 2–1/2 | 2.50 | 3 | 5 |
| 2–3/8 | 2.38 | 3 | 5 |
| 2–1/4 | 2.25 | 4 | 5 |
| 2–1/8 | 2.13 | 4 | 5 |
| 2 | 2.00 | 4 | 6 |
| 1–7/8 | 1.88 | 4 | 6 |
| 1–3/4 | 1.75 | 5 | 7 |
| 1–5/8 | 1.63 | 5 | 7 |
| 1–1/2 | 1.50 | 6 | 9* |
| 1–3/8 | 1.38 | 6 | 9* |
| 1–1/4 | 1.25 | 7 | 9* |
| 1–1/8 | 1.13 | 7 | 9* |
| 1 | 1.00 | 8 | 9* |
| 7/8 | 0.88 | 9 | 9* |
| 3/4 | 0.75 | 9* | 9* |
| 5/8 | 0.63 | 9* | 9* |
| 1/2 | 0.50 | 9* | 9* |
| 3/8 | 0.38 | 9* | 9* |

* This height-of-cut and/or mowing speed not recommended for 5 blade reels.

8 BLADE REEL

RM 2300/2600—D VARIABLE REEL SPEED SELECTION CHART

| HEIGHT OF CUT | | 3WD SPEEDS 3–5 MPH | 2WD SPEEDS 6–7 MPH |
|---------------|------|--------------------------|--------------------------|
| 2–1/2 | 2.50 | 3* | 3 |
| 2–3/8 | 2.38 | 3* | 3 |
| 2–1/4 | 2.25 | 3* | 3 |
| 2–1/8 | 2.13 | 3* | 3 |
| 2 | 2.00 | 3* | 3 |
| 1–7/8 | 1.88 | 3 | 4 |
| 1–3/4 | 1.75 | 3 | 4 |
| 1–5/8 | 1.63 | 3 | 4 |
| 1–1/2 | 1.50 | 4 | 5 |
| 1–3/8 | 1.38 | 4 | 5 |
| 1–1/4 | 1.25 | 4 | 6 |
| 1–1/8 | 1.13 | 5 | 7 |
| 1 | 1.00 | 5 | 9 |
| 7/8 | 0.88 | 6 | 9* |
| 3/4 | 0.75 | 7 | 9* |
| 5/8 | 0.63 | 9 | 9* |
| 1/2 | 0.50 | 9 | 9* |
| 3/8 | 0.38 | 9 | 9* |

* This height-of-cut and/or mowing speed not recommended for 8 blade reels.

TRAINING PERIOD

Before mowing with the Reelmaster, the Toro Company suggests you find a clear area and practice starting and stopping, raising and lowering cutting units, turning, etc. This training period will be beneficial to the operator in gaining confidence in the performance of the machine.

OPERATING INSTRUCTIONS

BEFORE MOWING

Inspect the area for debris and clear area if necessary. Determine the direction best to mow on the previous mowing direction. Always mow in an alternate pattern from the previous mowing, so that the grass blades will be less apt to lay down and therefore be difficult to gather between the reel blades and bedknife.

TRANSPORT OPERATION

Be sure the cutting units are in fully up position, move traction pedal stop from under pedal to allow full traction pedal travel and place throttle control in FAST position. While operating on slopes and uneven terrain, always reduce speed and use extreme caution before turning to reduce risk of tipping or losing control. Watch carefully for, and avoid, holes in the terrain, sudden drop-offs and other hidden hazards. To prevent costly damage and down time, familiarize yourself with the width of the Reelmaster. Do not attempt to pass between immovable objects placed close together.

INSPECTION AND CLEAN-UP AFTER MOWING

At the completion of mowing operation, thoroughly wash the machine with a garden hose – without a nozzle – so excessive water pressure will not cause contamination and damage to seals and bearings.

Make sure radiator screen, radiator and oil cooler are kept free of dirt or grass clippings. After cleaning, it is recommended the machine be inspected for possible hydraulic fluid leaks, damage or wear to hydraulic and mechanical components and the cutting units checked for sharpness and proper reel to bedknife adjustment.

DAILY MAINTENANCE CHECKLIST

Daily Maintenance: (duplicate this page for routine use)

Check proper section of Operator's Manual for fluid specifications

| Maintenance Check Item ▼ | Daily Maintenance Check For Week Of _____ | | | | | | |
|--|---|------|-----|-------|-----|-----|-----|
| | MON | TUES | WED | THURS | FRI | SAT | SUN |
| ✓ Safety Interlock Operation | | | | | | | |
| ✓ Brake Operation | | | | | | | |
| ✓ Engine Oil Level | | | | | | | |
| ✓ Cooling System Fluid Level | | | | | | | |
| Drain Water/Fuel Separator | | | | | | | |
| ✓ Air Filter, Dust Cup & Burp Valve | | | | | | | |
| ✓ Radiator & Screen for Debris | | | | | | | |
| ✓ Unusual Engine Noises ¹ | | | | | | | |
| ✓ Unusual Operating Noises | | | | | | | |
| ✓ Hydraulic System Oil Level | | | | | | | |
| ✓ Hydraulic Hoses for Damage | | | | | | | |
| ✓ Fluid Leaks | | | | | | | |
| ✓ Fuel Level | | | | | | | |
| ✓ Tire Pressure | | | | | | | |
| ✓ Instrument Operation | | | | | | | |
| ✓ Reel-to-Bedknife Adjustment | | | | | | | |
| ✓ Height-of-Cut Adjustment | | | | | | | |
| Lubricate All Grease Fittings ² | | | | | | | |
| Touch-up Damaged Paint | | | | | | | |

¹= Check glow plug and injector nozzles, if hard starting, excess smoke or rough running is noted.

²= Immediately after every washing, regardless of the interval listed.

Notation for areas of concern: Inspection performed by _____

| Item | Date | Information |
|------|------|-------------|
| 1 | | |
| 2 | | |
| 3 | | |
| 4 | | |
| 5 | | |
| 6 | | |
| 7 | | |
| 8 | | |

MAINTENANCE SCHEDULE

Minimum Recommended Maintenance Intervals

| Maintenance Procedure | Maintenance Interval & Service | | | |
|---|--------------------------------|-----------------|---|-----------------|
| Inspect Air Filter, Dust Cup and Burp Valve Lube All Grease Fittings † Change Engine Oil † Check Engine Belt Tension | Every 50hrs | Every 100hrs | Every 200hrs | Every 400hrs |
| † Change Engine Oil Filter † Check Traction Belt Tension Service Air Filter Replace Fuel Filter/Water Separator † Replace Hydraulic Filter † Torque Wheel Lug Nuts Replace Hydraulic Fluid Check Battery Level/Connections Inspect Traction Linkage Movement ‡ Check Engine RPM (idle and full throttle) | | | | |
| † Initial break in at 10 hours ‡ Initial break in at 50 hours | | | | |
| Replace Moving Hoses Replace Safety Switches Flush Cooling System and Replace Hoses Replace Thermostat Fuel Tank—Drain/Flush Hydraulic Tank—Drain/Flush | | | | |
| | | | Annual Recommendations: Items listed are recommended every 1000 hours or 2 years, whichever occurs first. | |

SERVICE INTERVAL CHART

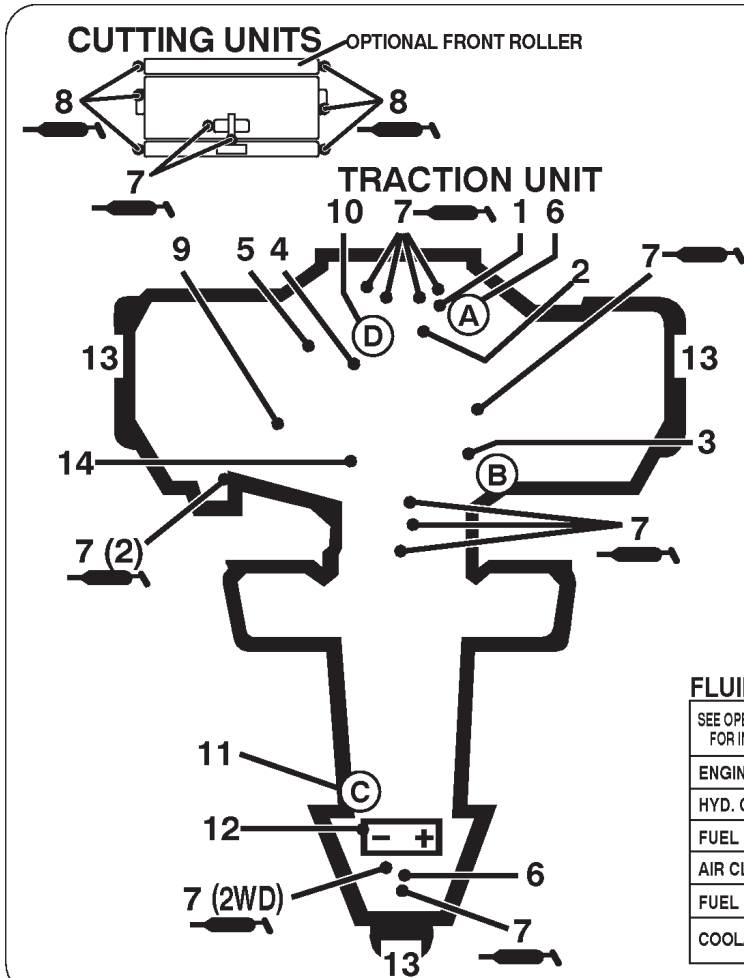

QUICK REFERENCE AID

CHECK/SERVICE

1. ENGINE OIL LEVEL
2. ENGINE OIL DRAIN (17mm socket)
3. HYDRAULIC OIL LEVEL
- bottom of sight glass
4. BELTS (Fan/Water Pump, Hydraulic Pump)
5. COOLANT LEVEL FILL-middle of horiz. neck
6. FUEL - Diesel Only
7. GREASE POINTS (every 50 hours) - 17-3WD; 18-2WD
8. GREASE POINTS (every 8 hours) - 12 or 18 (with optional front roller)
9. RADIATOR SCREEN
10. AIR CLEANER
11. WATER SEPARATOR/FUEL FILTER
12. BATTERY
13. TIRE PRESSURE: 12-16 psi (.8 - 1.1 bar)
14. FUSES

FLUID SPECIFICATIONS/CHANGE INTERVALS

| SEE OPERATOR'S MANUAL FOR INITIAL CHANGES. | FLUID TYPE | CAPACITY | | CHANGE INTERVAL | | FILTER PART NO. |
|---|--|----------|----------|-------------------------|---------|-----------------------|
| | | L | QT | FLUID | FILTER | |
| ENGINE OIL ^{-10°C to 40°C} _{14°F to 104°F} | SAE 10W-30CD | 2.8 | 3.0 | 50 HRS | 100 HRS | 85-4930 (A) |
| HYD. CIRCUIT OIL | MOBILFLUID 424 | 12.5 | 13 | 400 HRS | 200 HRS | 54-0110 (B) |
| FUEL FILTER | Inspect daily for contaminants & water | | | | 200 HRS | Perkins 130306041 (C) |
| AIR CLEANER | Clean every 50 hours. | | | | 200 HRS | 93-2195 (D) |
| FUEL | NO. 2-Diesel | 24.5 | 6.5 GAL. | Drain and flush, 2 yrs. | | |
| COOLANT | 50-50 Ethylene glycol water | 4.7 | 5 | | | |

93-6903

LUBRICATION

GREASING BEARINGS AND BUSHINGS

(Fig. 36-43)

The traction unit has grease fittings that must be lubricated regularly with No. 2 General Purpose Lithium Base Grease. If machine is operated under normal conditions, lubricate bearings and bushings after every 50 hours of operation. Bearings and bushings must be lubricated daily when operating conditions are extremely dusty and dirty. Dusty and dirty operating conditions could cause dirt to get into the bearings and bushings, resulting in accelerated wear.

The traction unit bearings and bushings that must be lubricated are: Steering column (Fig. 36), steering gears (2) (Under skirt below steering sector), steering shaft (2) (Fig. 37), lift arms (3) (Fig. 38), pivot rods (3) (Fig. 39), rear lift cylinder pivot (Fig. 40), traction pedal pivot (Fig. 41) and rear wheel (2WD only) (Fig. 42)

Also, apply grease to slots in cylinder support (Fig. 43).

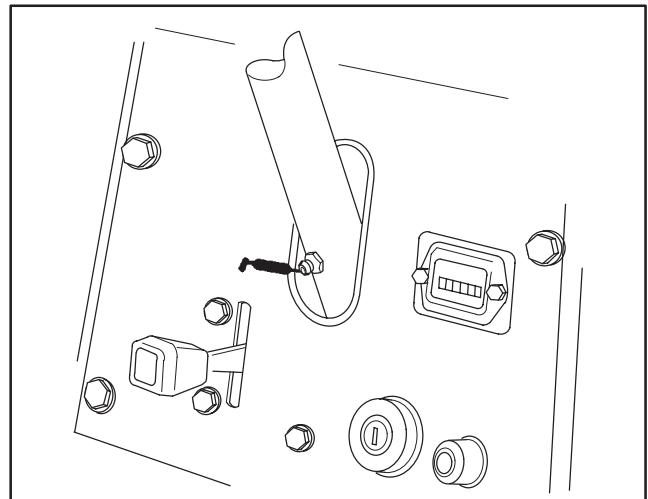

Figure 36

LUBRICATION

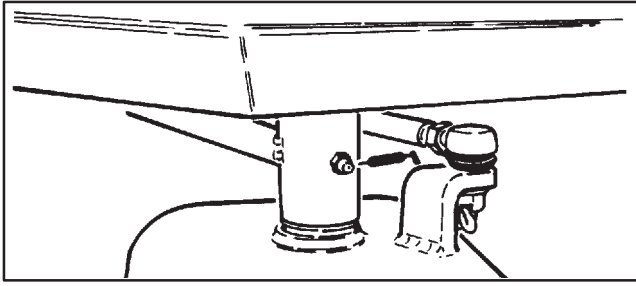

Figure 37

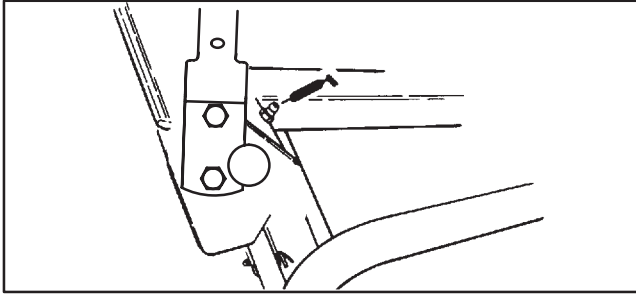

Figure 38

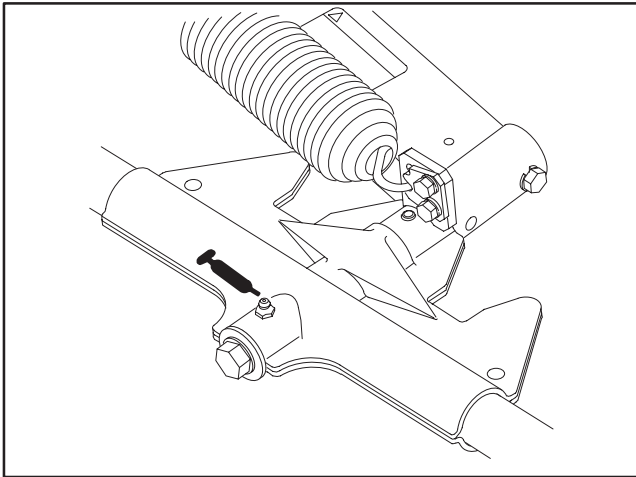

Figure 39

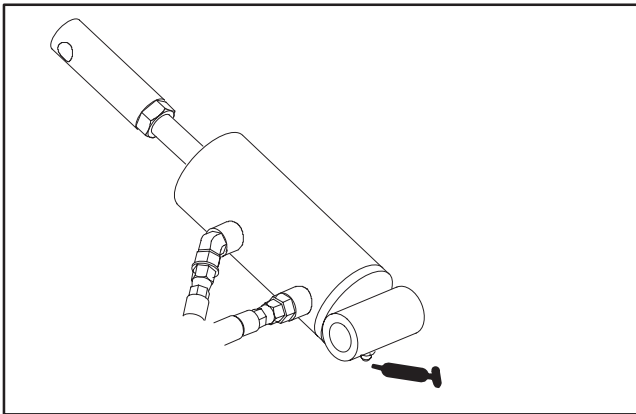

Figure 40

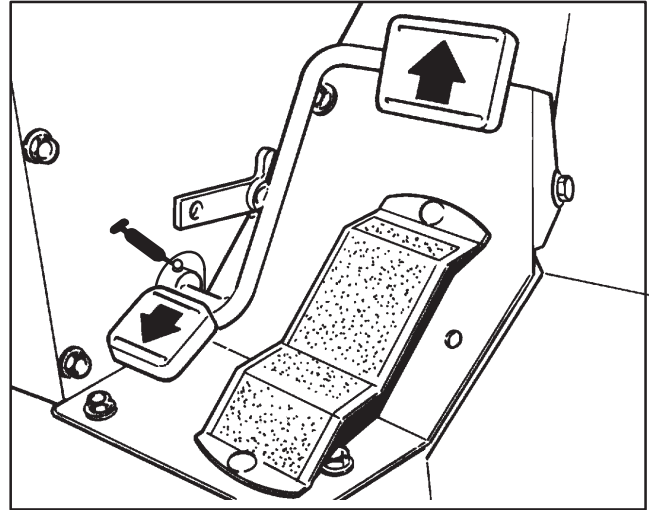

Figure 41

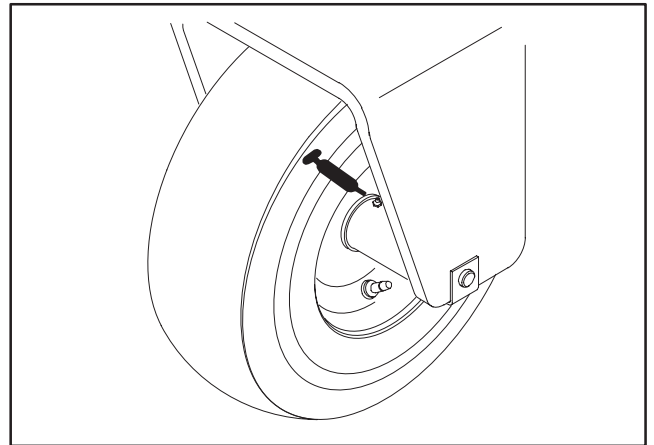

Figure 42

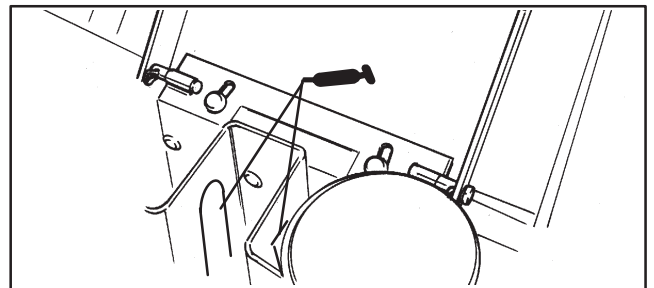

Figure 43

MAINTENANCE



CAUTION

Before servicing or making adjustments to the machine, stop engine and remove key from the switch.

HOOD REMOVAL (Fig. 44)

Hood may be easily removed to ease maintenance procedures in engine area of machine.

1. Unlatch and raise hood.
2. Remove cotter pin securing hood pivot to mounting brackets.

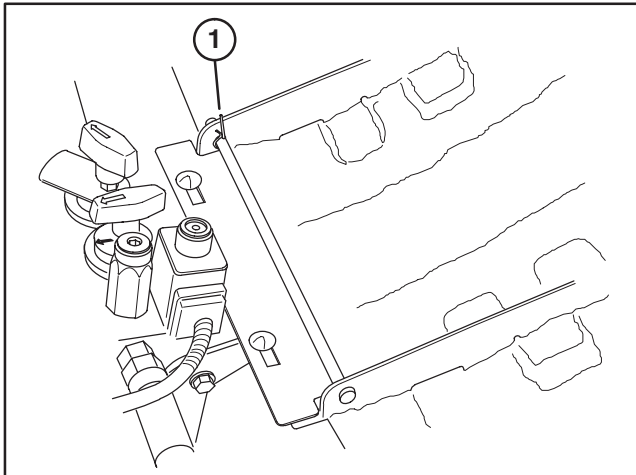

Figure 44
1. Cotter pin

3. Slide hood to right side, lift other side and pull out of brackets.
4. Reverse procedure to reinstall hood.

GENERAL AIR CLEANER MAINTENANCE

1. Check air cleaner body for damage which could possibly cause an air leak. Replace a damaged air cleaner body.
2. Service the air cleaner filter every 400 hours (more frequently in extreme dusty or dirty conditions). Do not over service air filter.
2. Be sure cover is sealing around air cleaner body.

SERVICING AIR CLEANER (Fig. 45)

1. Release latches securing air cleaner cover to air cleaner body. Separate cover from body. Clean inside of air cleaner cover.

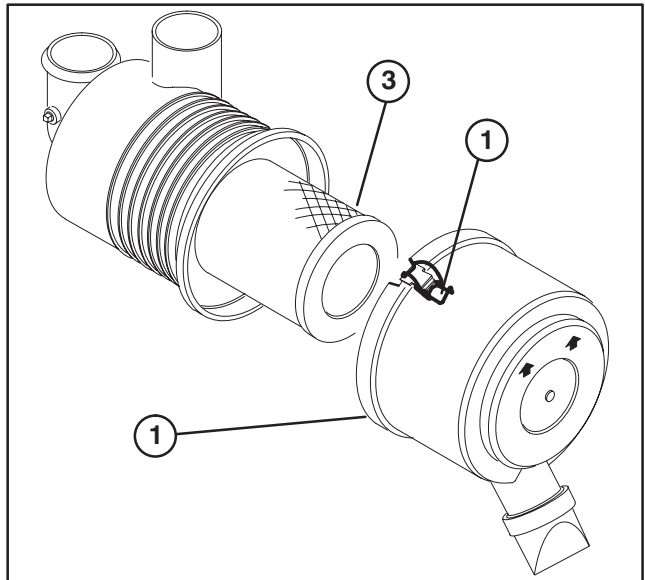

Figure 45

1. Air cleaner latches
2. Dust cup
3. Filter

2. Gently slide filter out of air cleaner body to reduce the amount of dust dislodged. Avoid knocking filter against air cleaner body.
3. Inspect filter and discard if damaged. Do not wash or reuse a damaged filter.

Washing Method

- A. Prepare a solution of filter cleaner and water and soak filter element about 15 minutes. Refer to directions on filter cleaner carton for complete information.
- B. After soaking filter for 15 minutes, rinse it with clear water. Maximum water pressure must not exceed 40 psi to prevent damage to the filter element. Rinse filter from clean side to dirty to side.
- C. Dry filter element using warm, flowing air (160°F) max), or allow element to air-dry. Do not use a light bulb to dry the filter element because damage could result.

Compressed Air Method

- A. Blow compressed air from inside to the outside of dry filter element. Do not exceed 100 psi to prevent damage to the element.
 - B. Keep air hose nozzle at least 2" from filter and move nozzle up and down while rotating the filter element. Inspect for holes and tears by looking through the filter toward a bright light.
5. Inspect new filter for shipping damage. Check sealing end of filter. Do not install a damaged filter.
 6. Insert new filter properly into air cleaner body. Make sure filter is sealed properly by applying pressure to outer rim of filter when installing. Do not press on flexible center of filter.
 7. Reinstall cover and secure latches. Make sure cover is positioned with TOP side up.

MAINTENANCE

CLEANING RADIATOR AND SCREEN

(Fig. 46)

To prevent the system from overheating, radiator screen, radiator and oil cooler must be kept clean. Check the screen, radiator and oil cooler daily and, if necessary, clean any debris off these parts. Clean these components more frequently in dusty dirty conditions.

1. Remove radiator screen.
2. Working from fan side of radiator, either spray the radiator with a hose or blow with compressed air.

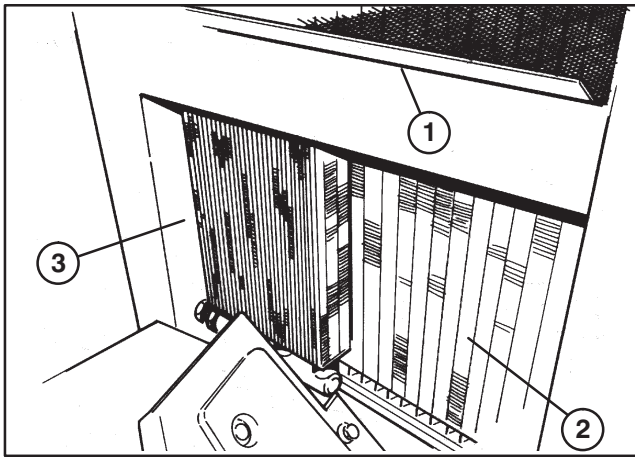

Figure 46

1. Radiator screen
2. Radiator
3. Oil cooler

3. Thoroughly clean oil cooler and any other debris that may have collected around components.
4. Clean screen and re-install.

CHANGING ENGINE OIL AND FILTER

Change oil and filter initially after the first 20 hours of operation, thereafter change oil every 50 hours and filter every 100 hours.

1. Locate engine oil drain plug on bottom of oil pan. Remove drain plug and let oil flow into drain pan. When oil stops, install drain plug.
2. Locate engine filter on front of engine. Remove oil filter. Apply a light coat of clean oil to the new filter seal before screwing it on. **DO NOT OVER-TIGHTEN.**
3. Add oil to crankcase, refer to Check Engine Oil.

CHANGING HYDRAULIC SYSTEM FLUID AND FILTER (Fig. 47–48)

The hydraulic system filter must be changed initially, after the first five hours of operation, and thereafter every 200 hours of operation or yearly, whichever comes first. Use a genuine Toro oil filter for replacement. The hydraulic fluid must be changed every 400 hours of operation or yearly, whichever comes first.

1. Park the machine on a level surface, lower the cutting units, set parking brake and turn the engine off.
2. If only the filter is to be changed, remove reservoir cap and insert reservoir plug (Fig. 57), to block outlet.

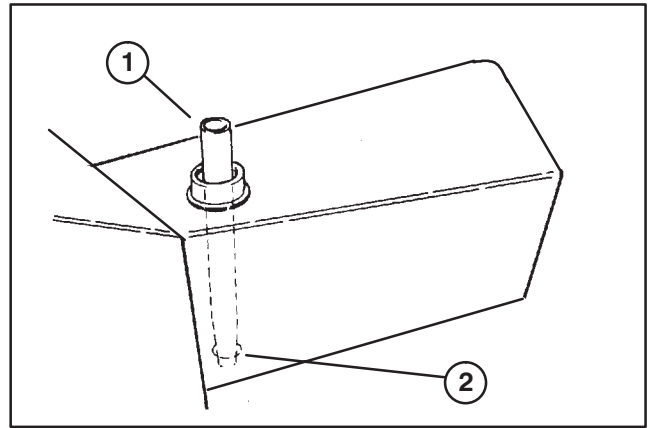

Figure 47

1. Reservoir plug
2. Reservoir outlet

This will retain most of the fluid in reservoir when filter is removed.

3. Clean the area around the hydraulic oil filter. Remove filter from the bottom of the filter housing and allow the oil to flow into a drain pan. Use bottom type filter wrench. Dispose of the oil filter properly.

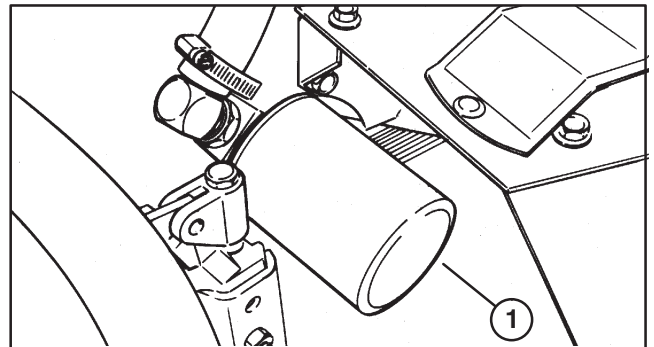

Figure 48

1. Hydraulic oil filter

4. Apply a film of oil on the filter gasket. Install filter by hand until gasket contacts mounting head; then tighten filter an additional three-fourths turn.
5. Fill the reservoir to proper level, refer to Check Hydraulic System Fluid.

MAINTENANCE

6. Place all controls in neutral or disengaged position and start engine. Run engine at lowest possible RPM to purge the system of air.
7. Run engine until lift cylinders extend and retract and forward and reverse wheel motion is achieved.
8. Stop the engine and check the oil level in reservoir, add oil if necessary.
9. Check all connections for leaks.

HYDRAULIC SYSTEM TEST PORTS (Fig. 49–50)

The test ports are used to test pressure in the hydraulic circuits. Contact your local Toro distributor for assistance.

1. Test Port #1 is used to forward traction pressure.
2. Test Port #2 is used to measure reverse traction pressure.

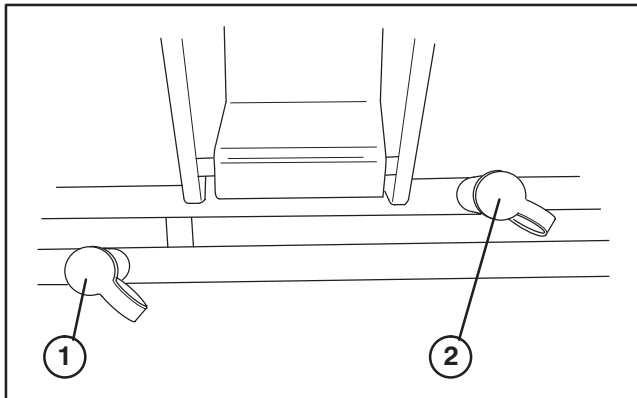

Figure 49

1. Test Port #1
2. Test port #2

3. Test Port #3 is used to measure reel circuit pressure.

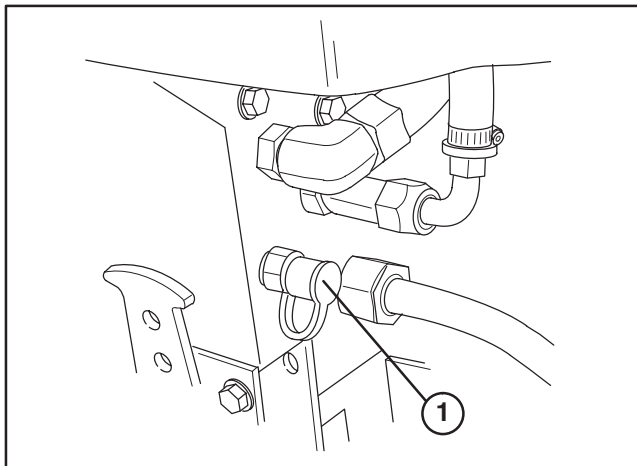

Figure 50

1. Test Port #3

REPLACING FUEL FILTER (Fig. 51)

Inspect fuel filter bowl, daily, for water or other contaminants. If water or other contaminants are present, they must be removed before commencing operation.

1. Close fuel shut-off above filter.
2. Unscrew nut securing bowl to filter head. Remove water or other contaminants from bowl.

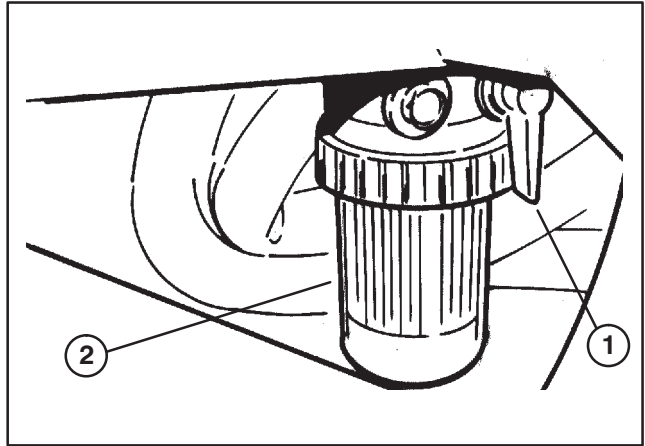

Figure 51

1. Fuel shut-off
2. Fuel filter

3. Remove and inspect fuel filter. Replace if dirty.



DANGER

Because diesel fuel is flammable, use caution when storing or handling it. Do not smoke while filling the fuel tank. Do not fill fuel tank while engine is running, hot, or when machine is in an enclosed area. Always fill fuel tank outside and wipe up any spilled diesel fuel before starting the engine. Store fuel in a clean, safety-approved container and keep cap in place. Use diesel fuel for the engine only; not for any other purpose.

4. Re-install bowl to filter head. Make sure O-ring is positioned properly between bowl mounting nut and filter head.
5. Open fuel shut-off above filter.
6. Open bleed screw on filter mounting head to re-fill bowl with fuel. Close bleed screw.

MAINTENANCE

ADJUSTING TRANSMISSION FOR NEUTRAL (Fig. 52)

If the machine “creeps” when the traction control pedal is in the neutral position, the neutral return mechanism must be adjusted.

1. Block up under the frame so one of the front wheels is off the floor. Place selector control in two wheel drive position.
2. Start engine, move throttle to SLOW and check front wheel that is off shop floor; it must not be rotating. Loosen pump plate nuts and rotate pump plate until creep does not occur in either direction. When wheel stops rotating, tighten nuts locking adjustment. Verify the adjustment with throttle in SLOW and FAST position.

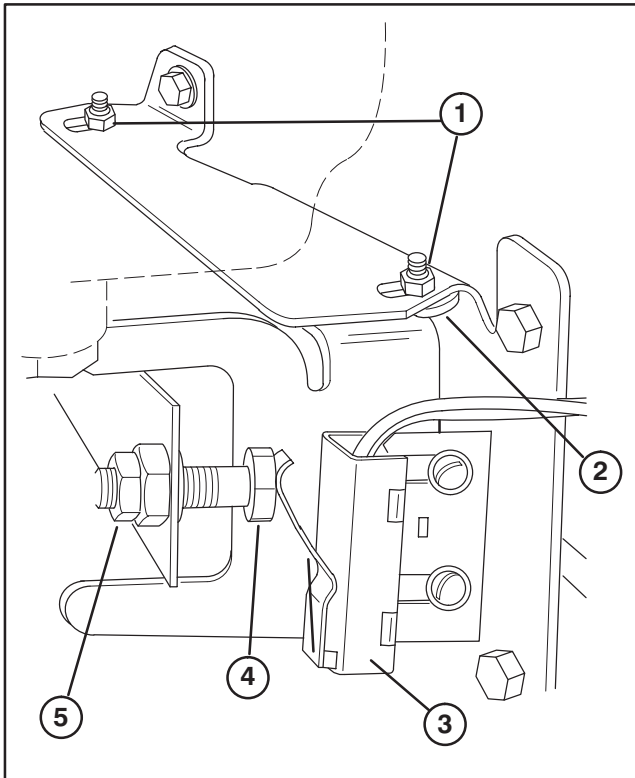

Figure 52

1. Pump plate
2. Pump plate mounting nuts
3. Neutral switch
4. Adjusting screw
5. Locknut

3. Should the wheel continue to rotate, check for the following:

- A. Ball bearing is loose or worn out.
- B. Loose or missing fasteners.
- C. Worn fasteners.
- D. Pump lever loose on control shaft.
- E. Weak or damaged leaf springs. Replace.
- F. Internal pump component malfunction.

4. After adjusting the pump plate, check neutral switch operation and if necessary, adjust as follows:

- A. Loosen locknut securing switch adjusting screw. Thread away from switch until capscrew head clears switch.
- B. Rotate adjusting screw toward switch until circuit through switch is made. Then, turn adjusting screw toward switch an additional 2–1/2 turns.
- C. Tighten locknut

BELT ADJUSTMENTS

Make sure belts are properly tensioned to assure proper operation of the machine and prevent unnecessary wear. On new belts, check tension after 8 hours operation.

Hydraulic Pump Belt (Fig. 53)

A new hydraulic pump belt should be tensioned so it deflects .120 inch with a 15–17 pound load applied midway in span of belt. A used belt should be tensioned so that it deflects .120 inch with a 11–13 pound load applied midway in span of belt.

1. Tighten nut on adjustment rod until desired belt tension is attained.

Note: Tighten belt to eliminate slippage (squealing under load) but do not overtighten.

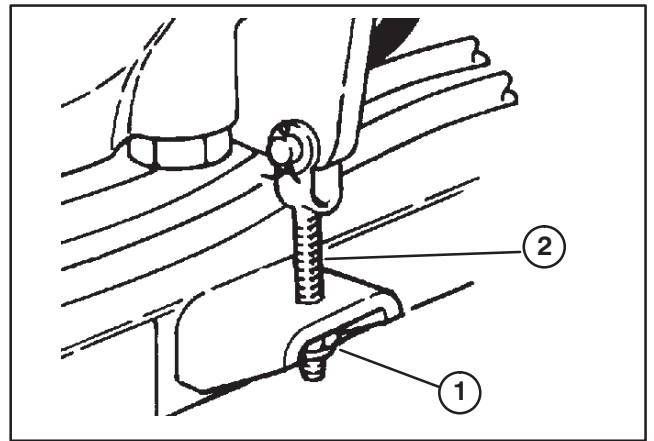

Figure 53

1. Nut
2. Adjustment rod

Engine Belt (Fig. 54)

The engine belt should be tensioned so it deflects .20 inch with a 2–3 pound load applied midway between crankshaft and alternator pulleys.

1. Loosen bolts securing alternator to engine and adjusting strap.

MAINTENANCE

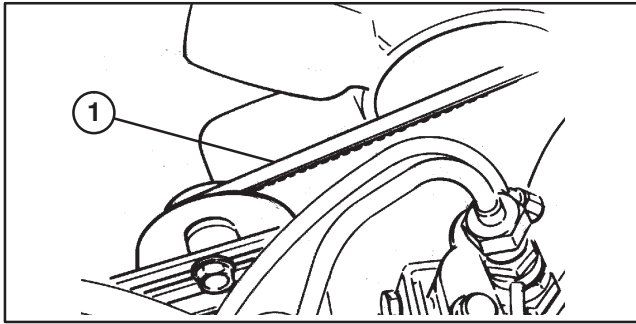

Figure 54
1. Engine belt

2. Adjust belt to proper tension and tighten bolts.

ADJUSTING TRACTION PEDAL (Fig. 55)

If traction pedal contacts footrest when pushed fully forward or maximum forward traction speed is unattainable, an adjustment to the traction pedal linkage is required.

1. To expose traction rod, remove screws securing right fender to frame and remove fender.
2. Loosen jam nuts on each end of traction rod.

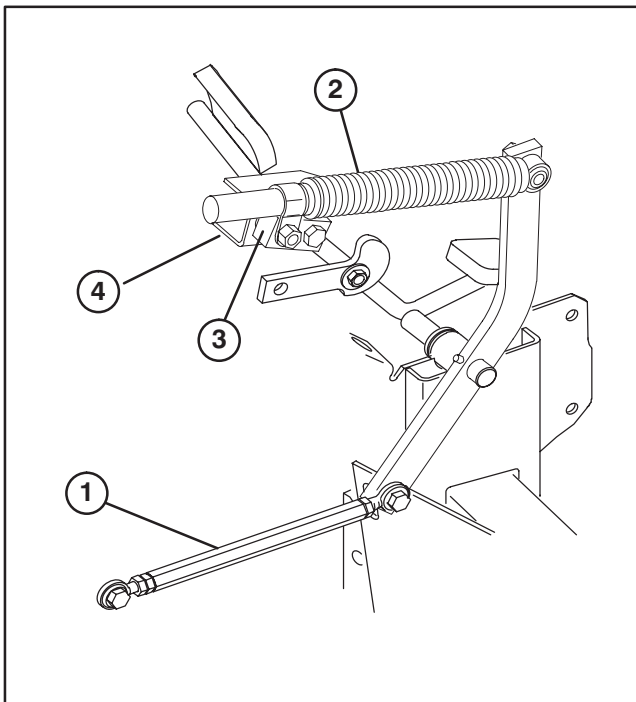

Figure 55

- | | |
|-----------------|-------------------|
| 1. Traction rod | 3. Damper pivot |
| 2. Damper | 4. Damper bracket |

3. Rotate rod until required pedal clearance or traction speed is attained.
4. Retighten jam nuts securing traction rod adjustment.
5. The stop for reverse travel (under pedal) may be adjusted for slower travel. Speeds in excess of 3 M.P.H. are not recommended.

ADJUST TRACTION PEDAL DAMPER (Fig. 55)

(Fig. 55)

1. To expose traction pedal damper, remove right hand panel.
2. Loosen locknut securing damper pivot to damper bracket.
3. Depress traction pedal fully forward.
4. Fully compress damper and then release it allowing it to extend .08". Tighten locknut securing adjustment.
5. When traction pedal is fully depressed in rearward direction, damper must contact reverse stop before extending damper.

HAND BRAKE ADJUSTMENT (Fig. 56)

1. Remove both front wheels.
2. Make sure brake is in the OFF position.
3. Loosen jam nut on clevis. Remove cotter pin securing top of clevis to upper brake lever. Rotate clevis, one turn at a time, to decrease distance between levers.

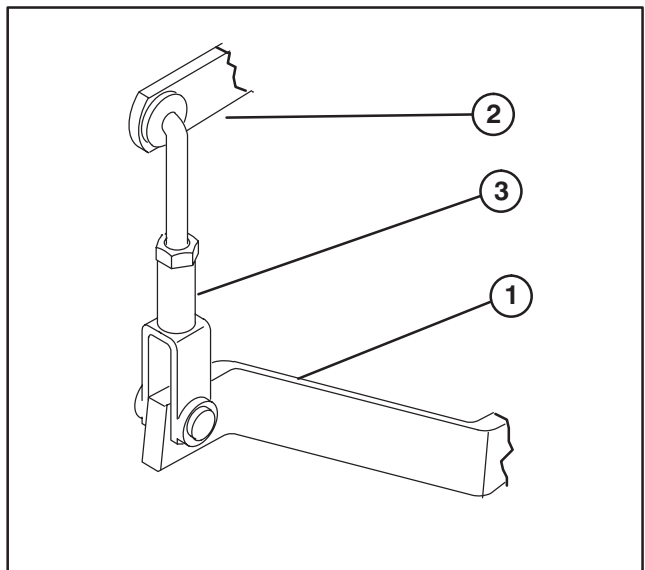

Figure 56

- | |
|----------------------|
| 1. Lower brake lever |
| 2. Upper brake lever |
| 3. Clevis |

4. Reinstall clevis to upper brake lever and tighten jam nut. Repeat procedure on opposite side of machine.
5. After any brake adjustment, operate the vehicle at a low speed (one mph or less) and check that brakes engage equally on both wheels. Readjust as necessary.

MAINTENANCE

BATTERY CARE

1. Battery electrolyte level must be properly maintained and the top of the battery kept clean. If the machine is stored in a location where temperatures are extremely high, the battery will run down more rapidly than if the machine is stored in a location where temperatures are cool.
2. Check the electrolyte level every 25 operating hours or, if machine is in storage, every 30 days.
3. Maintain cell level with distilled or demineralized water. Do not fill cells above the bottom of the split ring inside each cell. Install filler caps with vents pointing to the rear (toward fuel tank).

**CAUTION**

Wear safety goggles and rubber gloves when working with electrolyte. Charge the battery in a well ventilated place so gases produced while charging can dissipate. Since the gases are explosive, keep open flame and electrical spark away from the battery; do not smoke. Nausea may result if the gases are inhaled. Unplug charger from electrical outlet before connecting to, or disconnecting, charger leads from battery posts.

4. Keep top of battery clean by washing periodically with a brush dipped in ammonia or bicarbonate of soda solution. Flush the top surface with water after cleaning. Do not remove the fill caps while cleaning.
5. Battery cables must be tight on terminals to provide good electrical contact.

**WARNING**

Connecting cables to the wrong post could result in personal injury and/or damage to the electrical system.

6. If corrosion occurs at terminals, disconnect cables, negative (—) cable first and scrape clamps and terminals separately. Reconnect cables, positive (+) cable first and coat terminals with petroleum jelly.
7. Always disconnect battery cables, ground cable (—) first, to prevent possible wiring damage from short outs whenever working with the electrical system.

BATTERY STORAGE

If the machine will be stored more than 30 days, remove the battery and charge it fully. Either store it on the shelf on the machine. Leave the cables disconnected if stored on the machine. Store the battery in a cool atmosphere to avoid quick deterioration of the charge in the battery. To prevent battery from freezing, make sure it is fully charged. The specific gravity of a fully charged battery is 1.265 – 1.299.

FUSES (Fig. 57)

The fuses in machines electrical system are located on back of instrument panel.

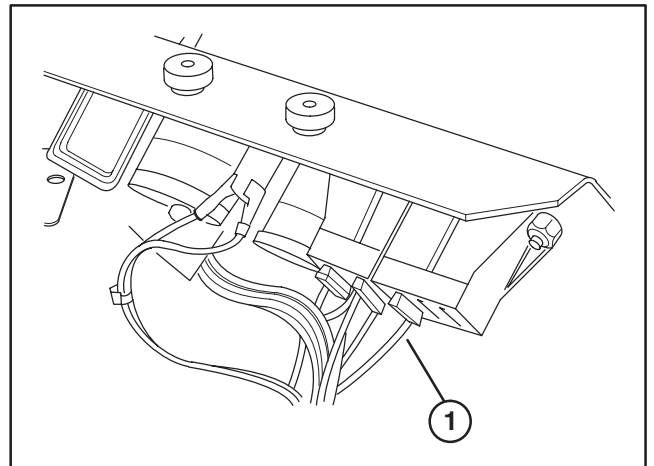

Figure 57
1. Fuses

| |
|----------------------------|
| CHARGING 20 A |
| ACCESSORIES 10 A |
| ENGINE 10 A |
| OPEN |
| FUSES |

93-6902

BACKLAPPING



DANGER

TO AVOID PERSONAL INJURY OR DEATH:

- Never place hands or feet in reel area while engine is running.
- While backlapping, reels may stall and then restart.
- Do not attempt to restart reels by hand or foot.
- Do not adjust reels while engine is running.
- If reel stalls, stop engine before attempting to clear reel.

1. Position machine on a clean, level surface, lower the cutting units, stop the engine, engage parking brake and remove key from ignition switch.
2. Unlatch and raise hood to expose controls.
3. Rotate backlap knob, on valve block, clockwise to backlap position. Rotate reel speed knob to position 1.



CAUTION

Do not rotate backlap knob from mow to backlap position while engine is running as damage to reels may occur.

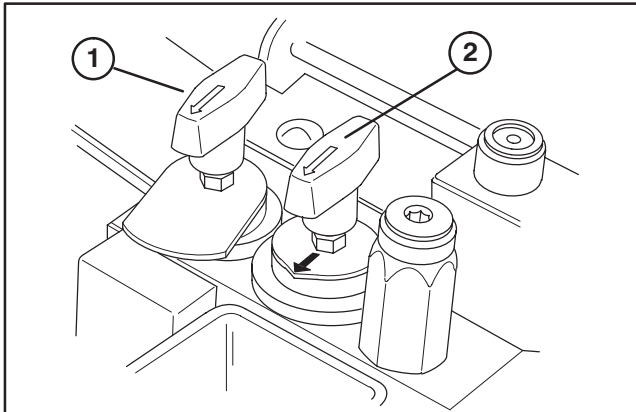

Figure 58

1. Backlap knob
2. Reel speed knob

4. Make initial reel to bedknife adjustments appropriate for backlapping on all cutting units. Start engine and set engine to low idle speed.

5. Engage reels by pulling out knob on instrument panel.

6. Apply lapping compound with long handled brush supplied with machine.



CAUTION

Be careful when lapping the reel because contact with the reel or other moving parts can result in personal injury.

7. To make an adjustment to the cutting units while backlapping, turn reels OFF by pushing in on knob on instrument panel and turning engine OFF. After adjustments have been completed, repeat steps 4–6.

8. When backlap operation is completed, stop the engine, rotate backlap knob clockwise to MOW position, set reel speed controls to desired mowing setting and wash all lapping compound off cutting units.

Note: Additional instructions and procedures on Backlapping are available in the TORO Sharpening Reel & Rotary Mowers Manual Form No. 80–300SL.

NOTE: For a better cutting edge, run a file across the front face of the bedknife when the lapping operation is completed. This will remove any burrs or rough edges that may have built up on the cutting edge.

ELECTRICAL SCHEMATIC

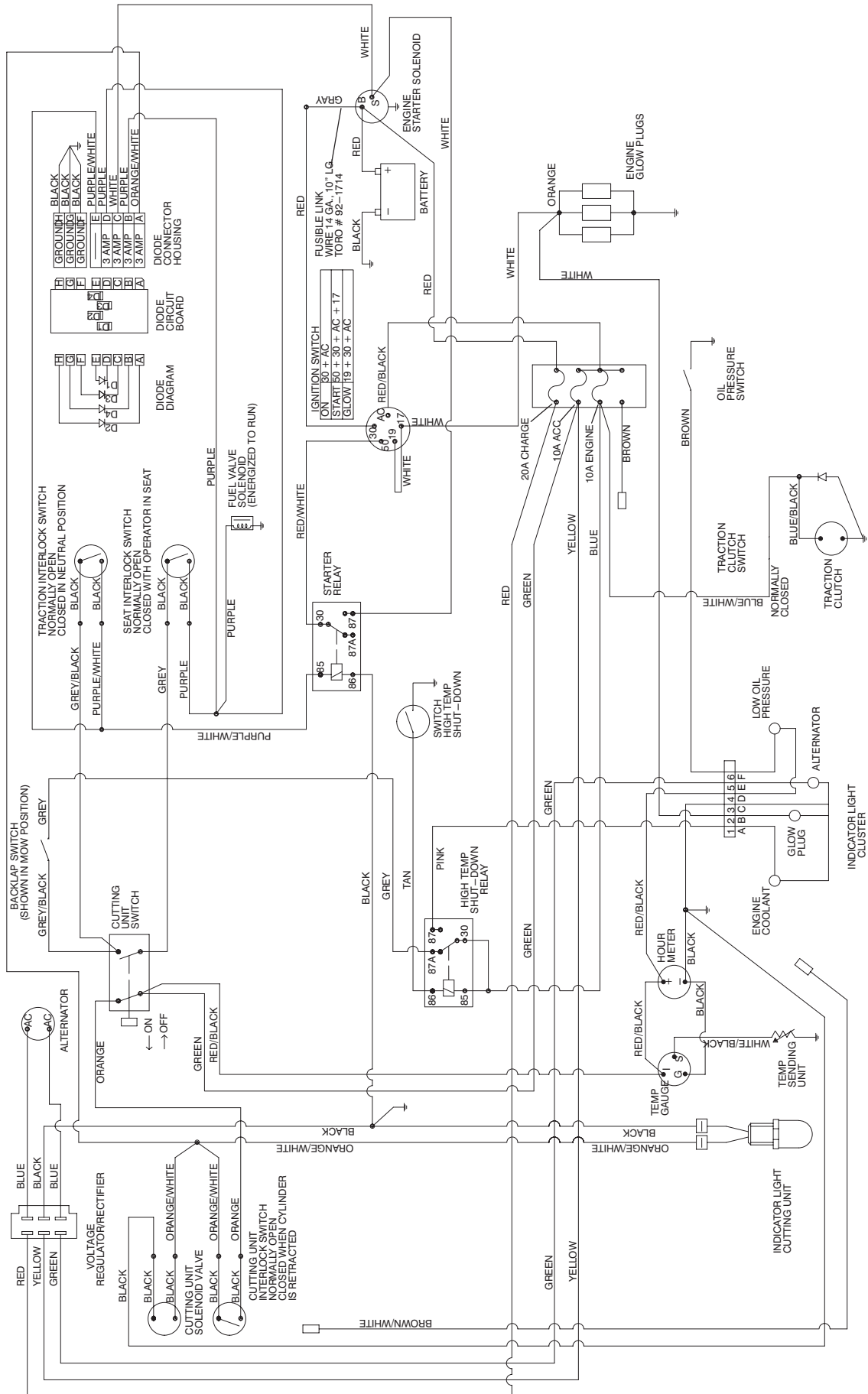

15° AND 20° SLOPE CHART

Read all safety decals and safety instructions in this manual .

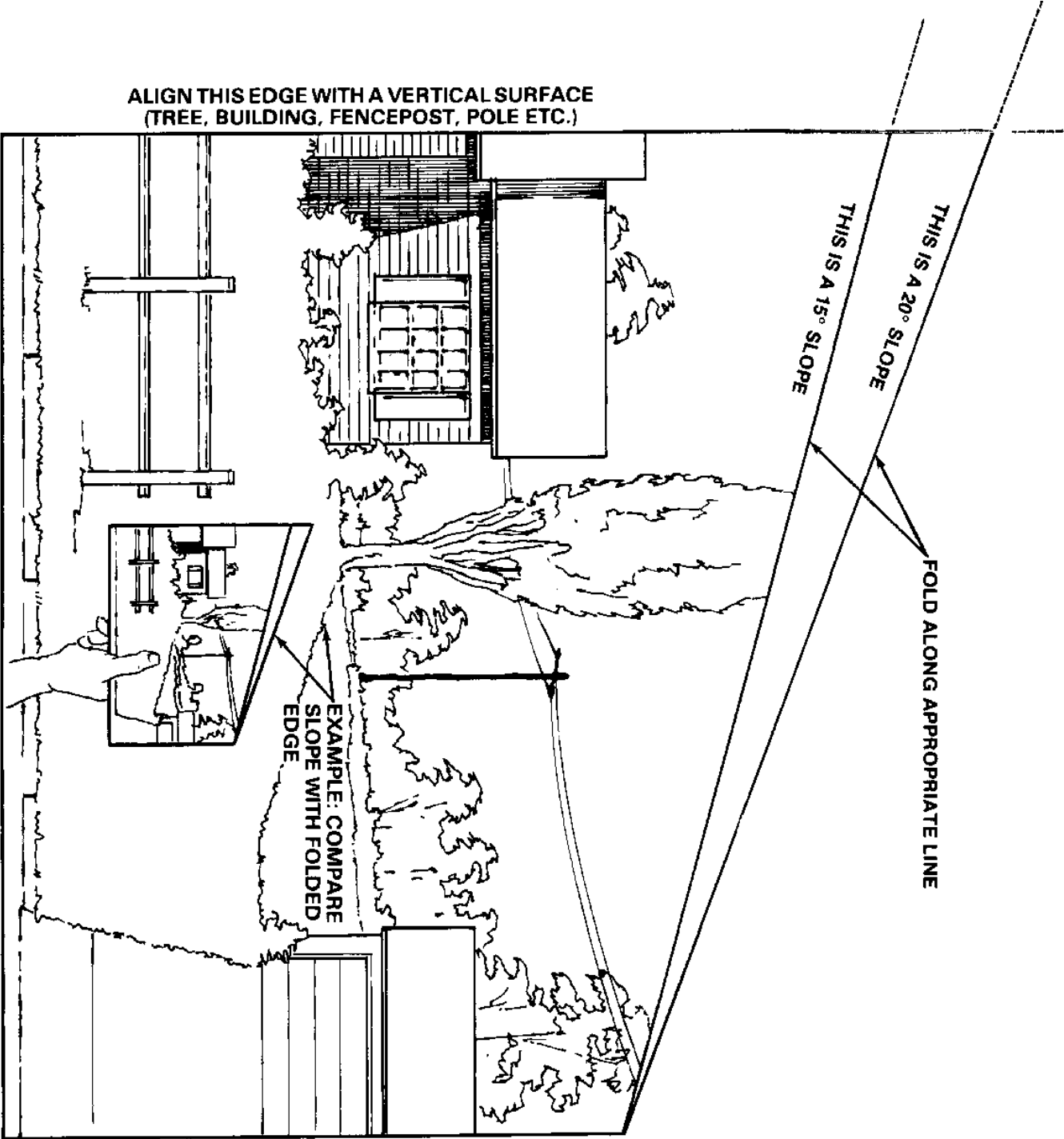

IDENTIFICATION AND ORDERING

MODEL AND SERIAL NUMBER

The mower has two identification numbers: a model number and a serial number. The two numbers are stamped into a plate that is riveted to the frame at rear of mower. In any correspondence concerning the mower, supply the model and serial numbers to assure that correct information and replacement parts are obtained.

Note: Do not order by reference number if a parts catalog is being used; use the part number.

To order replacement parts from an Authorized TORO Service Dealer, supply the following information:

1. Model and serial numbers of the mower.
2. Part number, description and quantity of part(s) desired.

I. CALIFORNIA EMISSION CONTROL SYSTEM WARRANTY STATEMENT

YOUR WARRANTY RIGHTS AND OBLIGATIONS

The California Air Resources Board and Ishikawajima–Shibaura Machinery Co., Ltd. (ISM) are pleased to explain the emission control system warranty on your 1995 and later utility or lawn and garden equipment engine. In California, new utility and lawn and garden equipment engines must be designed, built and equipped to meet the State's stringent anti-smog standards. ISM must warrant the California emission control system on your (utility or lawn and garden) equipment engine for the periods of time listed below provided there has been no abuse, neglect or improper maintenance of your (utility or lawn and garden) equipment engine.

Your California emission control system include parts such as the fuel injection pump, the fuel injector and the high pressure fuel oil line. Also included are the fuel filter element and the air cleaner element which are covered under this California emission control system warranty only to the first maintenance schedule replacement, if ISM supplies the fuel filter and air cleaner with the engine.

Where a warrantable condition exists, the manufacturer of your equipment or ISM's Engine Distributor will repair your utility or lawn and garden equipment engine at no cost to you including diagnosis, parts and labor (hereinafter such commitment is phrased "by ISM").

MANUFACTURER'S (ISM) WARRANTY COVERAGE

The 1995 and later utility, lawn and garden equipment engines are warranted for two years. If any emission-related part on your engine is defective, the part will be repaired or replaced by ISM.

OWNER'S WARRANTY RESPONSIBILITIES

- As the utility or lawn and garden equipment engine owner, you are responsible for the performance of the required maintenance listed in your Owner's Manual. ISM recommends that you retain all receipts covering maintenance on your said engine, but ISM cannot deny warranty solely for the lack of receipts or for your failure to ensure the performance of all scheduled maintenance.
- As the said equipment engine owner, you should be aware, however, that ISM may deny you warranty coverage if your said engine or a part has failed due to abuse, neglect, improper maintenance or unapproved modifications.
- You are responsible for presenting your said engine to the manufacturer of equipment or ISM's Engine Distributor as soon as the problem exists. The warranty repairs should be completed in a reasonable amount of time, not to exceed thirty (30) days. If you have any questions regarding your warranty rights and responsibilities, you should contact the Equipment Dealer from whom the equipment was purchased, or manufacturer of said equipment. If you need further assistance please contact ISM's Representative at (212) 599-8100 or FAX your concern to (212) 599-8111 to the attention of ISM's Representative.

II. MANUFACTURER'S (ISM) EXPLANATION OF EMISSION CONTROL SYSTEM WARRANTY COVERAGE

A. WARRANTY COMMENCEMENT DATE

The Warranty period commences on the date the engine powered utility, or lawn, or garden equipment is delivered to the first retail purchaser; or from the date the said equipment is first rented, loaned or leased prior to a sale to the first purchaser.

B. LENGTH OF COVERAGE

ISM warrants the initial owner and each subsequent purchaser that the engine emission control system is free from defects in materials and workmanship which cause the failure of a warranted California emission control system part for a period of two years as described in "A" above.

C. WHAT IS COVERED

1. REPAIR OR REPLACEMENT OF PARTS

Repair or replacement of any California emission control warranted part will be performed at no charge to the owner at a service center where the equipment was purchased or at ISM's engine distributor. To obtain the telephone number of your nearest authorized service center in California contact the manufacturer's dealer from whom you purchased your equipment or call ISM representative at 1-212-599-8100.

2. WARRANTY PERIOD

Any warranted part which is not scheduled for replacement as required maintenance in the written instructions of the Owner's Manual shall be warranted for the warranty period of two (2) years. If any such part fails during the period of coverage, it shall be repaired or replaced by the equipment manufacturer's dealer, or other franchised dealership or distributor certified to accommodate such emission repairs, and by certain arrangements, ISM will be ultimately responsible for the expense of parts and labor. And, any such part repaired or replaced under the warranty shall be warranted for the remaining warranty period.

Any warranted part which is scheduled only for regular inspection as required in the written instructions of the Owner's Manual shall be warranted for a period of two (2) years. Any written instruction in the Owner's Manual which indicates "repair or replace as necessary" shall not reduce the period of warranty coverage.

Any such part repaired or replaced under warranty by the equipment manufacturer's dealer, or other franchised engine dealership or distributor certified to accommodate such emission repairs, ISM will be ultimately responsible for the expense of parts and labor. And, any such part repaired or replaced under the warranty shall be warranted for the remaining warranty period.

3. DIAGNOSIS

Warranty services or repairs to the emission control system and availability of ISM original equipment parts shall be provided at all ISM certified distributors of ISM's engines. The owner shall not be charged for diagnostic labor which leads to the determination that a warranted part is in fact defective, provided that such diagnostic work is performed at a warranty station. And, providing that such defective part is not the result of abuse, neglect or improper maintenance of the engine as described in the Owner's Manual.

4. CONSEQUENTIAL DAMAGES

ISM shall be liable for damages to other engine components proximately caused by a failure under warranty of any warranted part.

D. WHAT IS NOT COVERED

1. ISM shall not be liable for failure of warranted emission control system parts or other parts proximately caused by a failure under warranty of any warranted part due to any add-on part to the engine's emission control system which has not been approved by ISM. And, ISM disclaims any liability to cover failures of the emission control system when unauthorized add-on modified parts are or have been added to the system.
2. ISM shall not be liable for failure of warranted emission control system parts or other parts proximately caused by a failure under warranty of any warranted part due to the use of diesel fuel, or any other fuel, which is not commercially available in California, and use of such fuel will invalidate this warranty.
3. ISM shall not be liable for failure of warranted emission control system parts or damages to other engine components proximately caused by a failure under warranty when such defective part is the result of abuse, neglect or improper maintenance of the engine as described in the Owner's Manual.

E. HOW TO FILE A CLAIM

All claims for California emission control warranty service including parts and labor is within the arrangements ISM has with its customers who purchase our engines (Distributors of our engines and their OEM customers as well as our customers) and it is not necessary for the owner of the ULGE engine to file a separate claim with ISM.

F. WHERE TO GET WARRANTY SERVICE

Repair or replacement of any California emission control warranted parts will be performed at no charge to the owner at a service center where the equipment was purchased or at ISM's engine distributor. To obtain the telephone number of your nearest authorized service center in California contact the manufacturer's dealer from whom you purchased your equipment or call ISM's representative at 1-212-599-8100.

G. MAINTENANCE, REPLACEMENT AND REPAIR OF EMISSION CONTROL SYSTEM AND RELATED PARTS

Any ISM approved replacement part may be used in the performance of any warranty maintenance or repairs on emission control system parts or components, and must be provided without charge to the owner if the part is still under the California emission control system warranty. Any replacement part that is equivalent in performance and durability may be used in non-warranty maintenance or repairs, and shall not reduce the warranty obligations ISM.

H. EMISSION CONTROL SYSTEM WARRANTY PARTS LIST

Following are the emission control system Warranty parts:

| Part Name |
|---|
| Fuel Injection Pump |
| Fuel Injector |
| Fuel Injection Pipe (High Pressure Fuel Oil Line) |
| Intake Manifold/Exhaust Manifold |
| Fuel Filter Element |
| Air Cleaner Element |

NOTE: When and if the fuel filter and/or air cleaner element is supplied by ISM, these parts are under warranty only to the first maintenance scheduled replacement, including making available any related hoses, clamps, connectors or nuts and bolts that may be related to the fastening of such emission control system warranty parts, to fasten such components directly or indirectly to engine.

I. MAINTENANCE STATEMENT

The UGLE equipment engine owner is responsible for the performance of the required maintenance, as defined by the equipment manufacturer's operator's manual, and such instructions are supplied to the equipment manufacturer by ISM directly or indirectly through ISM's Engine Distributor.

The Toro Commercial Products Two Year Limited Warranty

The Toro Company warrants your 1996 or newer Toro Commercial Product ("Product") purchased after January 1, 1997, to be free from defects in materials or workmanship for the period of time listed below. Where a warrantable condition exists, Toro will repair the Product at no cost to you including diagnosis, labor, parts, and transportation. This warranty begins on the date the Product is delivered to the original retail purchaser.

Warranty Duration: Two years or 1500 operational hours*, whichever occurs first.

***Product equipped with hour meter**

Owner Responsibilities:

As the Product owner, you are responsible for required maintenance and adjustments stated in your Owner's Manual. Failure to perform required maintenance and adjustments can be grounds for disallowing a warranty claim.

Instructions for Obtaining Warranty Service:

You are responsible for notifying the Commercial Products Distributor or Authorized Commercial Products Dealer from whom you purchased the Product as soon as you believe a warrantable condition exists.

If you need help locating a Commercial Products Distributor or Authorized Dealer, or if you have questions regarding your warranty rights or responsibilities, you may contact us at:

Toro Commercial Products Service Department
8111 Lyndale Avenue South
Minneapolis, MN, 55420-1196
Telephone: (612) 888-8801
Facsimile: (612) 887-8258
E-Mail: Commercial.Service@Toro.Com

Maintenance Parts:

Parts scheduled for replacement as required maintenance ("Maintenance Parts"), are warranted for the period of time up to the scheduled replacement time for that part.

Items/Conditions Not Covered:

Not all product failures or malfunctions that occur during the warranty period are defects in materials or workmanship. The items / conditions listed below are not covered by this warranty:

- Product failures which result from the use of non-Toro replacement parts, or from installation and use of add-on, modified, or unapproved accessories are not covered.
- Product failures which result from failure to perform required maintenance and/or adjustments are not covered.
- Product failures which result from operating the Product in an abusive, negligent or reckless manner are not covered.

- This warranty does not apply to parts subject to consumption through use unless found to be defective. Examples of parts which are consumed, or used up, during normal Product operation include, but are not limited to, blades, reels, bedknives, tines, spark plugs, castor wheels, tires, filters, belts, etc.
- This warranty does not apply to failures caused by outside influence. Items considered to be outside influence include, but are not limited to, weather, storage practices, contamination, use of unapproved coolants, lubricants, additives, or chemicals, etc.
- This warranty does not apply to normal "wear and tear" items. Normal "Wear and Tear" includes, but is not limited to, damage to seats due to wear or abrasion, worn painted surfaces, scratched decals or windows, etc.

Other Legal Disclaimers:

The above remedy of product defects through repair by an authorized distributor or dealer is the purchaser's sole remedy for any defect. This warranty gives you specific legal rights, and you may also have other rights which vary from state to state.

Except for the Emissions warranty referenced below, if applicable, there is no other express warranty. All implied warranties of merchantability and fitness for use are limited to the duration of the express warranty.

Some states do not allow limitations on how long an implied warranty lasts, so the above limitation may not apply to you.

The Toro Company is not liable for indirect, incidental or consequential damages in connection with the use of the Product, including any cost or expense of providing substitute Product or service during periods of malfunction or non-use.

Some states do not allow the exclusion of incidental or consequential damages, so the above exclusion may not apply to you.

Note to California residents: The Emissions Control System on your Product may be covered by a separate warranty meeting requirements established by the U.S. Environmental Protection Agency (EPA), or the California Air Resources Board (CARB). The hour limitations set forth above do not apply to the Emissions Control System Warranty. Refer to the California Emission Control Warranty Statement printed in your Owner's Manual or contained in the engine manufacturer's documentation for details.