



Tru Trak™ Sulky
Proline Mid Size Mower Attachment
Model No. 30110—210000001 and Up

Operator's Manual

Contents

	Page
Introduction	2
Safety	2
Setup	3
Loose Parts	3
Installing the Axle	3
Installing the Sulky Assemblies	6
Adjusting the Handle Height	6
Installing the Transport Hooks	6
Operation	7
Operating Tips	7
Positioning the Sulky for Transport	7
Maintenance	8
Recommended Maintenance Schedule	8
Checking Tire Pressure	8
Greasing the Sulky	8

Introduction

Thank you for purchasing a Toro product.

All of us at Toro want you to be completely satisfied with your new product, so feel free to contact your local Authorized Service Dealer for help with service, genuine replacement parts, or other information you may require.

Whenever you contact your Authorized Service Dealer or the factory, always know the model and serial numbers of your product. These numbers will help the Service Dealer or Service Representative provide exact information about your specific product. You will find the model and serial number plate at the location shown in Figure 1.

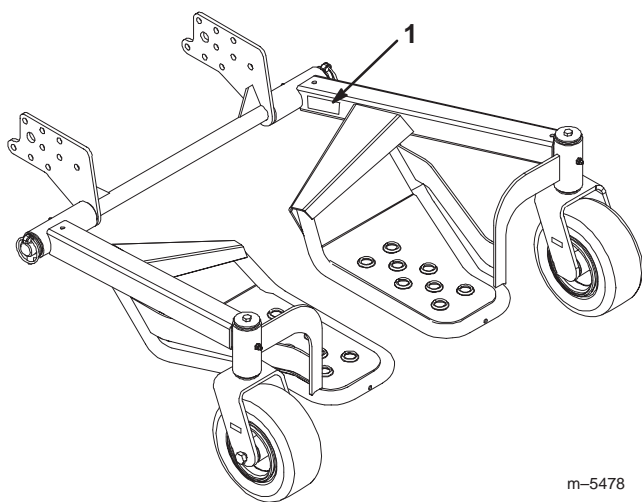

Figure 1

1. Model and serial number plate

For your convenience, write the product model and serial numbers in the space below.

Model No: _____
Serial No. _____

Read this manual carefully to learn how to operate and maintain your product correctly. Reading this manual will help you and others avoid personal injury and damage to the product. Although we design, produce and market safe, state-of-the-art products, you are responsible for using the product properly and safely. You are also responsible for training persons, who you allow to use the product, about safe operation.

The warning system in this manual identifies potential hazards and has special safety messages that help you and others avoid personal injury, even death. **Danger**, **Warning**, and **Caution** are signal words used to identify the level of hazard. However, regardless of the hazard, be extremely careful.

Danger signals an extreme hazard that will cause serious injury or death if the recommended precautions are not followed.

Warning signals a hazard that may cause serious injury or death if the recommended precautions are not followed.

Caution signals a hazard that may cause minor or moderate injury if the recommended precautions are not followed.

Two other words are also used to highlight information. **Important** calls attention to special mechanical information, and **Note** emphasizes general information worthy of special attention.

Safety

Improper use or maintenance by the operator or owner can result in injury. To reduce the potential for injury, comply with these safety instructions and always pay attention to the safety alert ⚠ symbol, which means CAUTION, WARNING, or DANGER—“personal safety instruction.” Failure to comply with the instruction may result in personal injury or death.

General Operation

- Do not modify the sulky or use it on non-approved machines.
- Ensure that the sulky is properly attached to the machine and is in good working order prior to use.
- Allow only the machine operator on the sulky.

- Do not allow use of the sulky by untrained operators.
- Use appropriate personal protective apparatus for eyes, ears, feet, hands, and head.
- Practice operating the machine without the sulky until familiar with the controls.
- Practice operation of the machine with sulky attached on large open, level terrain with no obstacles present before use. The sulky will affect the machine operation, especially on slopes, when turning, and when stopping.
- Use caution when riding the sulky over curbs, rocks, roots, or other obstructions.
- Slow down before making turns and use extra caution on rough terrain and on slopes.
- Travel across slopes, avoiding operation on steep slopes.
- Look behind and down before backing up to be sure of a clear path. Use extra care when operating in reverse.
- Dismount and latch the sulky in the transport position when loading and unloading the machine.

Setup

Loose Parts

DESCRIPTION	QTY.	USE
Axle	1	Attach the axle to the traction unit
Spacer plate	2	
Bolt, 3/8 x 1-3/8 in.	6	
Locknut, 3/8 in.	6	
Bolt, 3/8 x 4-1/2 in. (for use on a T-bar, gear drive machine only)	2	
Left sulky assembly	1	Attach the sulky assemblies to the axle
Right sulky assembly	1	
Washer, 1-3/4 in.	2	
Lynch pin	2	
Hook	2	Install the transport hooks
Shoulder bolt	2	
Curved washer	2	
Washer, 3/4 in.	2	
Locknut, 5/16 in.	2	

Installing the Axle

The procedure for installing the axle on your machine varies, depending on the drive system and control mechanism of your machine. Refer to the section below that pertains to your machine.

Installing the Axle on a Hydro Drive Machine with a T-bar Control

1. Stop the engine, wait for all moving parts to stop, and remove the ignition key.
2. Remove the 6 bolts and nuts securing the bottom of the two pulley guards on the sides of the frame (3 bolts and nuts on each side) (Fig. 2).

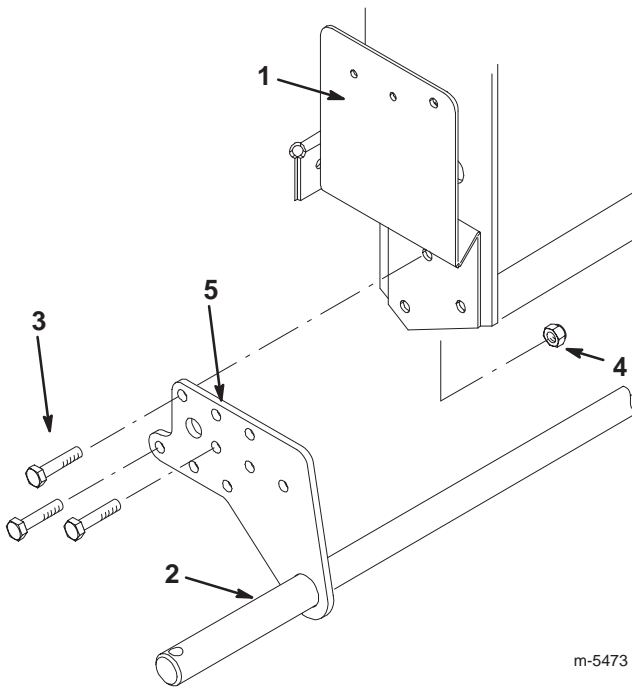

Figure 2

- | | |
|---------------------------|--------------------------|
| 1. Pulley guard | 4. Locknut, 3/8 in. |
| 2. Axle | 5. Axle mounting bracket |
| 3. Bolts, 3/8 x 1-3/8 in. | |

3. Using the 6 bolts (3/8 x 1-3/8 in.) and locknuts (3/8 in.) supplied with the sulky, install the axle as illustrated in Figure 2.

Note: You can install the axle in one of 3 horizontal positions (Fig. 3). For a T-bar controlled machine, the average person will get the best results using the rear holes; however, if a large person will be using the sulky, you may want to install it using the middle or front holes to give the operator more room.

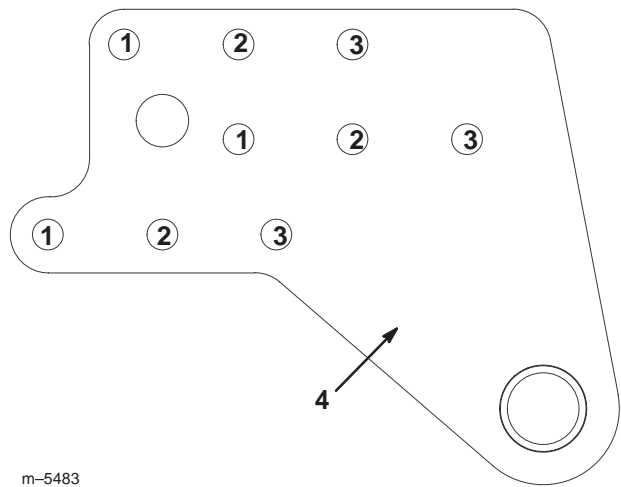

Figure 3

- | | |
|---------------------------------------|--------------------------------|
| 1. Front holes (pistol grip machines) | 3. Rear holes (T-bar machines) |
| 2. Middle holes | 4. Axle mounting bracket |

Installing the Axle on a Gear Drive Machine with a T-bar Control

1. Stop the engine, wait for all moving parts to stop, and remove the ignition key.
2. Remove the 4 bolts and nuts securing the bottom of the two pulley guards on the sides of the frame (2 bolts and nuts on each side) (Fig. 4).

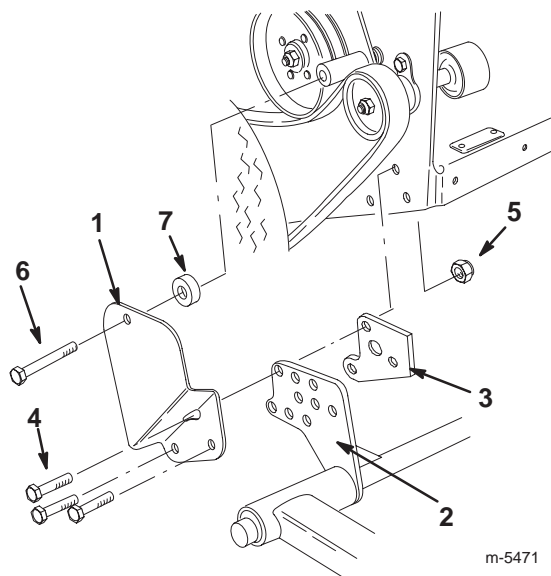

Figure 4

- | | |
|---------------------------|--------------------------|
| 1. Pulley guard | 5. Locknut, 3/8 in. |
| 2. Axle mounting bracket | 6. Bolt, 3/8 x 4-1/2 in. |
| 3. Large spacer | 7. Small spacer |
| 4. Bolts, 3/8 x 1-3/8 in. | |

- Remove the long bolt and nut securing the top of each pulley guard (Fig. 4) and discard the bolt.
- Insert the axle mounting brackets between the pulley guards and the frame (Fig. 4).
- Insert the large spacers between the axle mounting brackets and the frame, lining up the holes (Fig. 4).

Note: You can install the axle in one of 3 horizontal positions (Fig. 3). For a T-bar controlled machine, the average person will get the best results using the rear holes; however, if a large person will be using the sulky, you may want to install it using the middle or front hole to give the operator more room.

- Using the 6 bolts (3/8 x 1-3/8 in.) and locknuts (3/8 in.) supplied with the sulky, secure the bottom of the pulley guards, the axle, and the spacers as illustrated in Figure 4.
- Slide the small spacers between the top of the pulley guards and the mounting tube on the frame, and secure them using 2 bolts (3/8 x 4-1/2 in.) and the nuts removed in step 3 (Fig. 4).

Installing the Axle on a Machine with Pistol Grip Controls

- Stop the engine, wait for all moving parts to stop, and remove the ignition key.
- Insert the axle mounting brackets between the pulley guards and the frame (Fig. 5).

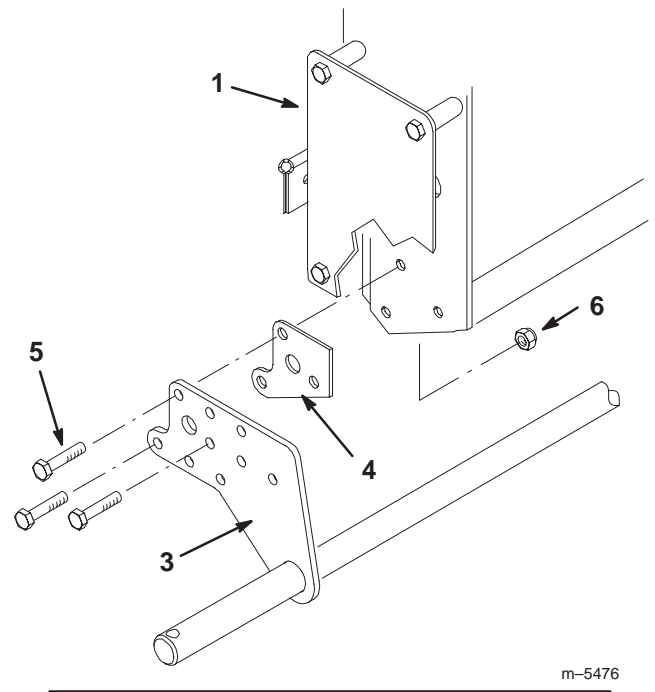

Figure 5

- | | |
|-------------------------------------|---------------------------|
| 1. Pistol grip, hydro drive machine | 3. Axle mounting bracket |
| 2. Pistol grip, gear drive machine | 4. Spacer |
| | 5. Bolts, 3/8 x 1-3/8 in. |
| | 6. Locknut, 3/8 in. |

- Insert the large spacers between the axle brackets and the frame, lining up the holes (Fig. 5).

Note: You can install the axle in one of 3 horizontal positions (Fig. 3). For a pistol grip machine, use the front holes.

- Using the 6 bolts (3/8 x 1-3/8 in.) and locknuts (3/8 in.) supplied with the sulky, secure the axle and the spacers as illustrated in Figure 5.

Note: You may have difficulty installing one of the bolts on the right side due to interference with the traction control lever. If this happens, disconnect the control rod from the pistol grip (Fig. 6) to drop the lever out of the way. When finished, reconnect the control rod.

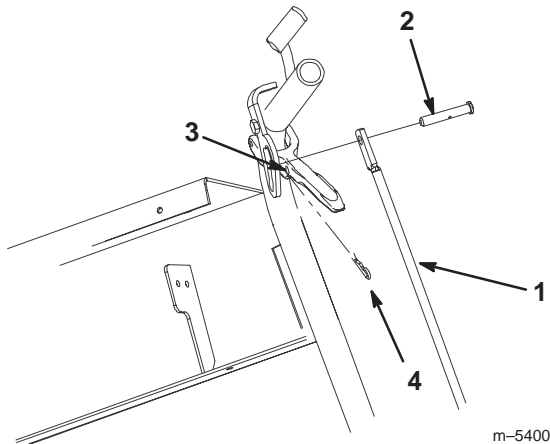

Figure 6

- | | |
|----------------|-------------------|
| 1. Control rod | 3. Pistol grip |
| 2. Clevis pin | 4. Hairpin cotter |

Installing the Sulky Assemblies

- Slide the mounting tube on each sulky assembly over the ends of the axle with the foot rests towards the inside (Fig. 7).

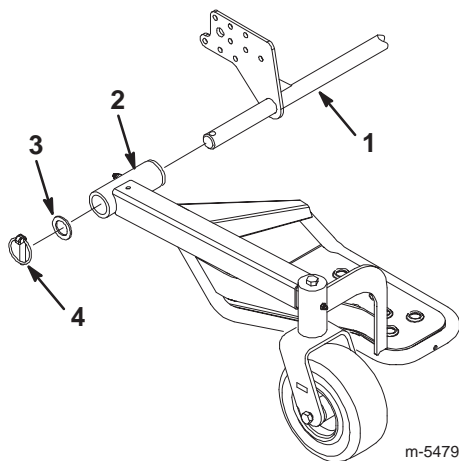

Figure 7

- | | |
|-------------------|----------------------|
| 1. Axle | 3. Washer, 1-3/4 in. |
| 2. Sulky assembly | 4. Lynch pin |

- Secure the sulky assemblies using a washer (1-3/4 in.) and lynch pin on each side (Fig. 7).
- Grease the sulky; refer to Greasing the Sulky, page 8.

Adjusting the Handle Height

Because the sulky raises you several inches off of the ground, adjust the handle height to accommodate you on the sulky comfortably. Refer to your machine Operator's Manual for more information on changing the handle height.

Important On a hydro drive, pistol grip machine, **do not** use the highest handle position; use the middle position. Using the highest position may damage the controls.

Installing the Transport Hooks

- Pivot the left sulky assembly up until it is near the pulley guard (Fig. 8).

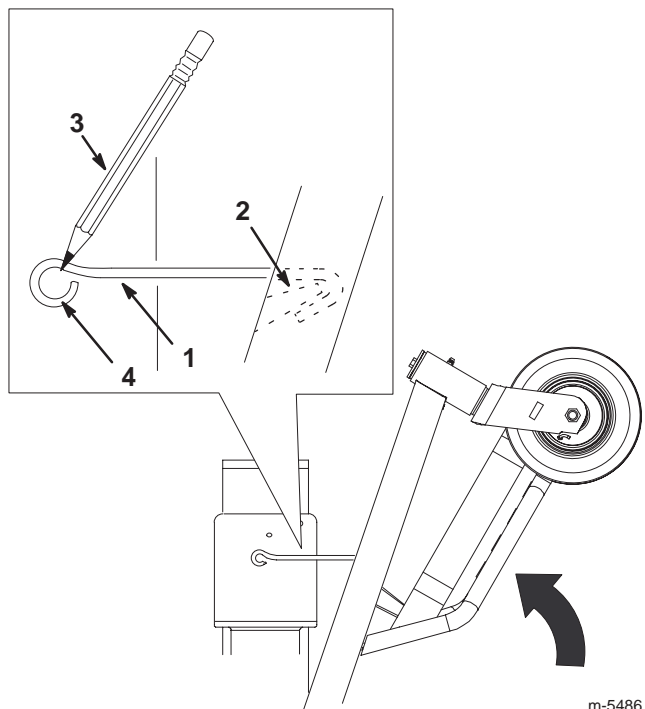

Figure 8

- | | |
|-------------------|----------------------|
| 1. Transport hook | 3. Mark the location |
| 2. Toe guard | 4. Eye of the hook |

- Position the hook over the toe guard on the sulky and the eye end of the hook against the pulley guard (Fig. 8).
- Adjust the height of the sulky and the position of the eye until it is in a clear location on the pulley guard, both on the outside and inside of the guard, then tie the sulky in place.

Important The sulky must be at least 1-1/2 in. (3.8 cm) from any contact point such as the machine handle or the gear shift lever (when pushed to the right and left) on gear drive machines. Position the hook so that it is as close to horizontal as possible.

4. If a hole does not exist in or near this location, mark the location of the eye.
5. Drill a 9/32 in. hole at the marked location.
6. Install the shoulder bolt, curved washer (cup facing inward), hook, washer (3/4 in.), and locknut (5/16 in.) (Fig. 9).

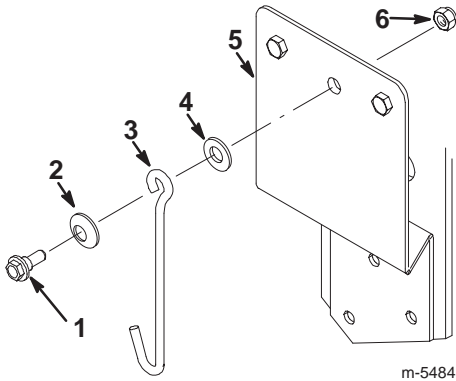

Figure 9

- | | |
|-------------------|----------------------|
| 1. Shoulder bolt | 4. Washer, 3/4 in. |
| 2. Curved washer | 5. Pulley guard |
| 3. Transport hook | 6. Locknut, 5/16 in. |

7. Repeat steps 1 through 6 for the right sulky assembly.
8. Untie the sulky assemblies.

Operation

Operating Tips

- Drive slowly and take time to learn how the sulky moves when using it for the first time.
- Use care when turning to ensure that you do not swing yourself and the sulky into obstacles.
- When turning, lean forward and toward the direction of the turn to help in keeping your balance.

- If your machine is a gear drive, pistol grip machine, you may need to adjust the wheel drive tension; refer to your machine *Operator's Manual*.

Positioning the Sulky for Transport

Before placing the machine on a trailer, lift each sulky assembly up and secure them with the transport hooks (Fig. 10). This will keep the sulky from bouncing during transport and make the machine more compact.

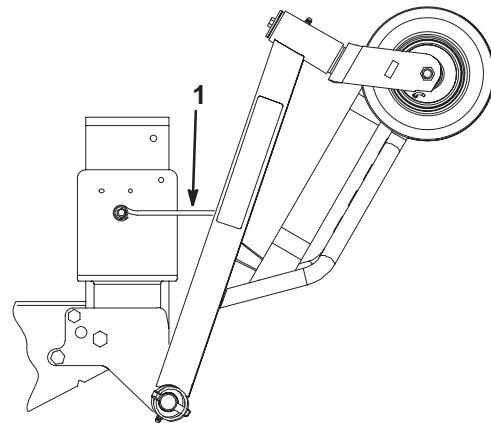
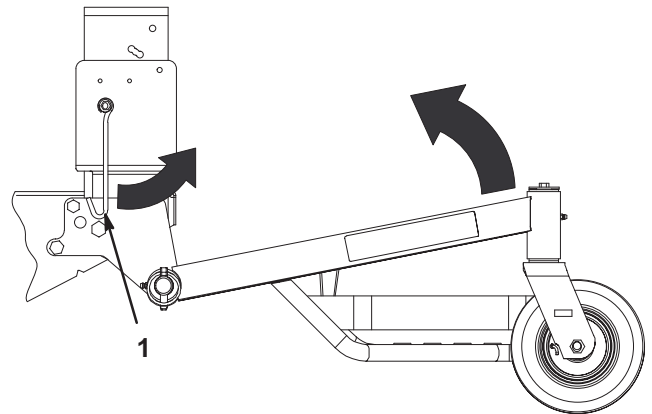

Figure 10

1. Transport hook

Maintenance

Recommended Maintenance Schedule

Maintenance Service Interval	Maintenance Procedure
8 hours	<ul style="list-style-type: none">• Check the tire pressure.
25 hours	<ul style="list-style-type: none">• Grease all fittings.
Storage Service	<ul style="list-style-type: none">• Grease all fittings.• Check the tire pressure.• Paint chipped surfaces.

Checking Tire Pressure

Ensure that the caster wheel tires are filled with air to 50 psi (345 kPa) every 8 operating hours or before each use.

Greasing the Sulky

Grease all grease fittings every 25 operating hours and immediately after every washing.

Grease Type: General-purpose grease.

1. Clean the grease fittings with a rag.
2. Connect a grease gun to each fitting (Fig 11).

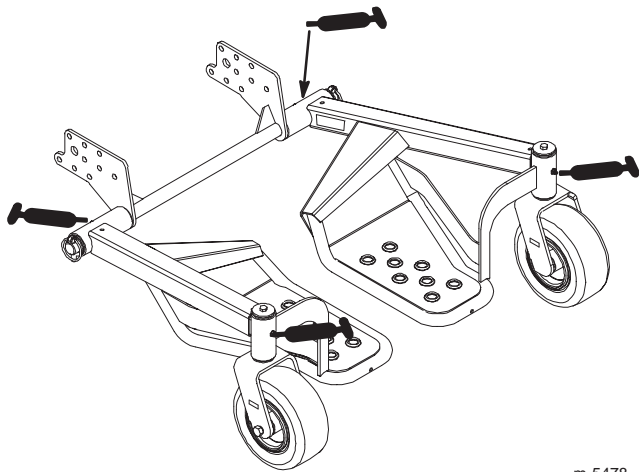

Figure 11

3. Pump grease into the fittings until grease begins to ooze out of the bearings.
4. Wipe up any excess grease.