



**Z287L**

**Z-Master<sup>®</sup> with 72" SFS Side Discharge Mower**

**Model No. 74214-21000001 & Up**

**Operator's Manual**



## Warning



**The engine exhaust from this product contains chemicals known to the State of California to cause cancer, birth defects, or other reproductive harm.**

Because in some areas there are local, state, or federal regulations requiring that a spark arrester be used on the engine of this mower, a spark arrester is incorporated with the muffler assembly.

**Important** This engine is equipped with a spark arrester muffler. It is a violation of California Public Resource Code Section 4442 to use or operate this engine without a spark arrester muffler on any forest-covered, brush-covered or grass-covered land. Other states or federal areas may have similar laws.

This spark ignition system complies with Canadian ICES-002.

Ce système d'allumage par étincelle de véhicule est conforme à la norme NMB-002 du Canada.

**The enclosed Engine Owner's Manual is supplied for information regarding The U.S. Environmental Protection Agency (EPA) and the California Emission Control Regulation of emission systems, maintenance and warranty.**

**Keep this engine Owner's Manual with your unit. Should this engine Owner's Manual become damaged or illegible, replace immediately. Replacements may be ordered through the engine manufacturer.**

# Contents

	Page
Introduction .....	3
Safety .....	3
Safe Operating Practices .....	3
Toro Mower Safety .....	5
Slope Chart .....	7
Safety and Instruction Decals .....	9
Gasoline and Oil .....	13
Recommended Gasoline .....	13
Using Stabilizer/Conditioner .....	13
Filling the Fuel Tank .....	13
Check Engine Oil Level .....	13
Assembly .....	14
Loose Parts .....	14
Install Drive Wheels .....	14
Tire Pressure .....	14
Install Seat Retaining Rod .....	14

	Page
Install Motion Control Levers .....	15
Activate the Battery .....	15
Install Battery .....	16
Check Engine Oil Level .....	17
Check Side Discharge Chute .....	17
Check the Leveling of Mower Deck .....	17
Cooling System .....	17
Greasing the Bearings .....	18
Hydraulic System .....	18
Operation .....	19
Think Safety First .....	19
Controls .....	19
Parking Brake .....	20
Starting and Stopping the Engine .....	20
Operating the Power Take Off (PTO) .....	21
The Safety Interlock System .....	22
Driving Forward or Backward .....	22
Stopping the Machine .....	23
Instruments .....	23
Fuel Tanks .....	23
Adjusting Height-of-Cut .....	23
Adjusting Anti-Scalp Rollers .....	24
Positioning the Seat .....	24
Pushing the Machine by Hand .....	24
Transporting Machines .....	25
Loading Machines .....	25
Using the Lift Assist Lever .....	26
Using the Z-Stand .....	26
Tips for Mowing Grass .....	27
Maintenance .....	29
Recommended Maintenance Schedule .....	29
Cutting Blades .....	30
Air Cleaner .....	32
Engine Oil .....	32
Cooling System .....	34
Spark Plug .....	36
Fuel Filter .....	37
Fuel Tank .....	38
Servicing the Spark Arrester .....	38
Greasing and Lubrication .....	38
Greasing the Bearings .....	39
Tire Pressure .....	39
Wheel Hub Slotted Nut .....	39
Castor Pivot Bearing Adjustment .....	40
Hydraulic System .....	40
Adjusting Motion Controls .....	42
Throttle Lever Adjustment .....	43
Replacing the Pump Drive Belt .....	44
Adjustment Parking Brake .....	44

	Page
Fuse .....	44
Battery .....	45
Mower Leveling .....	46
Clean Under Deck .....	46
Belt Inspection .....	47
Replacing the Deck Belt .....	47
Replacing the PTO Drive Belt .....	47
Replacing the Grass Deflector .....	49
Waste Disposal .....	49
Mercury Tilt Switch .....	49
Mercury Tilt Switch Disposal .....	50
Wiring Diagram .....	51
Cleaning and Storage .....	52
Troubleshooting .....	53
The Toro Total Coverage Guarantee .....	56

**Model No:** \_\_\_\_\_

**Serial No.** \_\_\_\_\_

Read this manual carefully to learn how to operate and maintain your product correctly. Reading this manual will help you and others avoid personal injury and damage to the product. Although we design, produce and market safe, state-of-the-art products, you are responsible for using the product properly and safely. You are also responsible for training persons, who you allow to use the product, about safe operation.

The warning system in this manual identifies potential hazards and has special safety messages that help you and others avoid personal injury, even death. **Danger**, **Warning**, and **Caution** are signal words used to identify the level of hazard. However, regardless of the hazard, be extremely careful.

**Danger** signals an extreme hazard that will cause serious injury or death if the recommended precautions are not followed.

**Warning** signals a hazard that may cause serious injury or death if the recommended precautions are not followed.

**Caution** signals a hazard that may cause minor or moderate injury if the recommended precautions are not followed.

Two other words are also used to highlight information. **Important** calls attention to special mechanical information, and **Note** emphasizes general information worthy of special attention.

Determine the left and right side of the machine from the normal operating position.

# Introduction

Thank you for purchasing a Toro product.

All of us at Toro want you to be completely satisfied with your new product, so feel free to contact your local Authorized Service Dealer for help with service, genuine replacement parts, or other information you may require.

Whenever you contact your Authorized Service Dealer or the factory, always know the model and serial numbers of your product. These numbers will help the Service Dealer or Service Representative provide exact information about your specific product. You will find the model and serial number plate at the location shown in Figure 1.

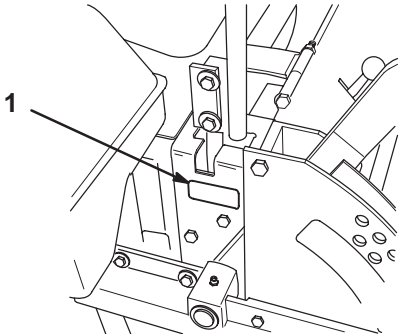

**Figure 1**

- 1. Model and serial number plate

For your convenience, write the product model and serial numbers in the space below.

# Safety

**This machine meets or exceeds the B71.4 1999 specifications of the American National Standards Institute, in effect at time of production.**

**Note:** The addition of certain attachments that do not meet American National Standards Institute certification will cause noncompliance of this machine.

**Improper use or maintenance by the operator or owner can result in injury. To reduce the potential for injury, comply with these safety instructions and always pay attention to the safety alert ▲ symbol, which means CAUTION, WARNING, or DANGER—“personal safety instruction.” Failure to comply with the instruction may result in personal injury or death.**

# Safe Operating Practices

The following instructions are from ANSI standard B71.4—1999.

## Training

- Read the Operator's Manual and other training material. If the operator(s) or mechanic(s) can not read English it is the owner's responsibility to explain this material to them.
- Become familiar with the safe operation of the equipment, operator controls, and safety signs.
- All operators and mechanics should be trained. The owner is responsible for training the users.
- Never let children or untrained people operate or service the equipment. Local regulations may restrict the age of the operator.
- The owner/user can prevent and is responsible for accidents or injuries occurring to himself or herself, other people or property.

## Preparation

- Evaluate the terrain to determine what accessories and attachments are needed to properly and safely perform the job. Only use accessories and attachments approved by the manufacturer.
- Wear appropriate clothing including hard hat, safety glasses and ear protection. Long hair, loose clothing or jewelry may get tangled in moving parts.
- Inspect the area where the equipment is to be used and remove all objects such as rocks, toys and wire which can be thrown by the machine.
- Use extra care when handling gasoline and other fuels. They are flammable and vapors are explosive.
  - Use only an approved container
  - Never remove gas cap or add fuel with engine running. Allow engine to cool before refueling. Do not smoke.
  - Never refuel or drain the machine indoors.
- Check that operator's presence controls, safety switches and shields are attached and functioning properly. Do not operate unless they are functioning properly.

## Operation

- Never run an engine in an enclosed area.

- Only operate in good light, keeping away from holes and hidden hazards.
- Be sure all drives are in neutral and parking brake is engaged before starting engine. Only start engine from the operator's position. Use seat belts if provided.
- Slow down and use extra care on hillsides. Be sure to travel in the recommended direction on hillsides. Turf conditions can affect the machine's stability. Use caution while operating near drop-offs.
- Slow down and use caution when making turns and when changing directions on slopes.
- Never raise deck with the blades running.
- Never operate with the PTO shield, or other guards not securely in place. Be sure all interlocks are attached, adjusted properly, and functioning property.
- Never operate with the discharge deflector raised, removed or altered, unless using a grass catcher.
- Do not change the engine governor setting or overspeed the engine.
- Stop on level ground, lower implements, disengage drives, engage parking brake (if provided), shut off engine before leaving the operator's position for any reason including emptying the catchers or unclogging the chute.
- Stop equipment and inspect blades after striking objects or if an abnormal vibration occurs. Make necessary repairs before resuming operations.
- Keep hands and feet away from the cutting units.
- Look behind and down before backing up to be sure of a clear path.
- Never carry passengers and keep pets and bystanders away.
- Slow down and use caution when making turns and crossing roads and sidewalks. Stop blades if not mowing.
- Be aware of the mower discharge direction and do not point it at anyone.
- Do not operate the mower under the influence of alcohol or drugs
- Use care when loading or unloading the machine into a trailer or truck
- Use care when approaching blind corners, shrubs, trees, or other objects that may obscure vision.

## Maintenance and storage

- Disengage drives, lower implement, set parking brake, stop engine and remove key or disconnect spark plug wire. Wait for all movement to stop before adjusting, cleaning or repairing.
- Clean grass and debris from cutting units, drives, mufflers, and engine to help prevent fires. Clean up oil or fuel spillage.
- Let engine cool before storing and do not store near flame.
- Shut off fuel while storing or transporting. Do not store fuel near flames or drain indoors.
- Park machine on level ground. Never allow untrained personnel to service machine.
- Use jack stands to support components when required.
- Carefully release pressure from components with stored energy.
- Disconnect battery or remove spark plug wire before making any repairs. Disconnect the negative terminal first and the positive last. Reconnect positive first and negative last.
- Use care when checking blades. Wrap the blade(s) or wear gloves, and use caution when servicing them. Only replace blades. Never straighten or weld them.
- Keep hands and feet away from moving parts. If possible, do not make adjustments with the engine running.
- Charge batteries in an open well ventilated area, away from spark and flames. Unplug charger before connecting or disconnecting from battery. Wear protective clothing and use insulated tools.
- Keep all parts in good working condition and all hardware tightened. Replace all worn or damaged decals.

## Toro Mower Safety

The following list contains safety information specific to Toro products or other safety information that you must know that is not included in the ANSI standards.

This product is capable of amputating hands and feet and throwing objects. Always follow all safety instructions to avoid serious injury or death.

This product is designed for cutting and recycling grass or, when equipped with a grass bagger, for catching cut grass. Any use for purposes other than these could prove dangerous to user and bystanders.

## General Operation

- Allow only responsible adults who are familiar with the instructions to operate the machine.
- Be sure the area is clear of other people before mowing. Stop the machine if anyone enters the area.
- Do not mow in reverse unless absolutely necessary. Always look down and behind before and while backing.
- Be aware of the mower discharge direction and do not point it at anyone. Do not operate the mower without either the entire grass catcher or the guard in place.
- Slow down before turning. Sharp turns on any terrain may cause loss of control.
- Turn off blades when not mowing.
- Keep hands, feet, hair and loose clothing away from attachment discharge area, underside of mower and any moving parts while engine is running.
- Stop the engine before removing the grass catcher or unclogging the chute.
- Mow only in daylight or good artificial light.
- Watch for traffic when operating near or crossing roadways.
- Do not touch equipment or attachment parts which may be hot from operation. Allow to cool before attempting to maintain, adjust or service.
- Before operating a machine with ROPS (roll over protection) be certain the seat belts are attached to prevent the seat from pivoting forward.
- Use only Toro-approved attachments. Warranty may be voided if used with unapproved attachments.

## Slope Operation

Slopes and ramps are a major factor related to loss-of-control and tip-over accidents, which can result in severe injury or death. All slopes and ramps require extra caution. If you cannot back up the slope or if you feel uneasy on it, do not mow it.

### DO

- If a steep slope must be ascended, back up the hill, and drive forward down the hill, keeping the machine in gear.
- Remove obstacles such as rocks, tree limbs, etc. from the mowing area. Watch for holes, ruts or bumps, as uneven terrain could overturn the machine. Tall grass can hide obstacles.
- Use slow speed so that you will not have to stop while on the slope.

- Follow the manufacturer's recommendations for wheel weights or counterweights to improve stability.
- Use extra care with grass catchers or other attachments. These can change the stability of the machine.
- Keep all movement on slopes slow and gradual. Do not make sudden changes in speed or direction.
- Avoid starting or stopping on a slope. If tires lose traction, disengage the blades and proceed slowly straight down the slope.
- When operating machine on slopes, banks or near drop offs, always have ROPS (roll over protection) installed.
- When operating a machine with ROPS (roll over protection) always use seat belt.
- Be certain that the seat belt can be released quickly if the machine is driven or rolls into ponds or water.
- Check carefully for overhead clearances (i.e. branches, doorways, electrical wires) before driving under any objects and do not contact them.
- Battery acid is poisonous and can cause burns. Avoid contact with skin, eyes and clothing. Protect your face, eyes and clothing when working with a battery.
- Battery gases can explode. Keep cigarettes, sparks and flames away from battery.
- Hydraulic fluid escaping under pressure can penetrate the skin and cause injury. Use cardboard or paper to find hydraulic leaks. Never use your hands.

## **DO NOT**

- Do not mow slopes exceeding 15 degrees.
- Avoid turning on slopes. If you must turn, turn slowly and gradually downhill, if possible.
- Do not mow near drop-offs, ditches, or embankments. The machine could suddenly turn over if a wheel goes over the edge of a cliff or ditch, or if an edge caves in.
- Do not mow on wet grass. Reduced traction could cause sliding.
- Do not try to stabilize the machine by putting your foot on the ground.
- Do not use a grass catcher on steep slopes. Heavy grass bags could cause loss of control or overturn the machine.

## **Service**

- Never store the machine or fuel container inside where there is an open flame, such as near a water heater or furnace.
- Keep nuts and bolts tight, especially the blade attachment bolts. Keep equipment in good condition.
- Never tamper with safety devices. Check safety systems for proper operation before each use.
- Use only genuine replacement parts to ensure that original standards are maintained.
- Check brake operation frequently. Adjust and service as required.

# Slope Chart

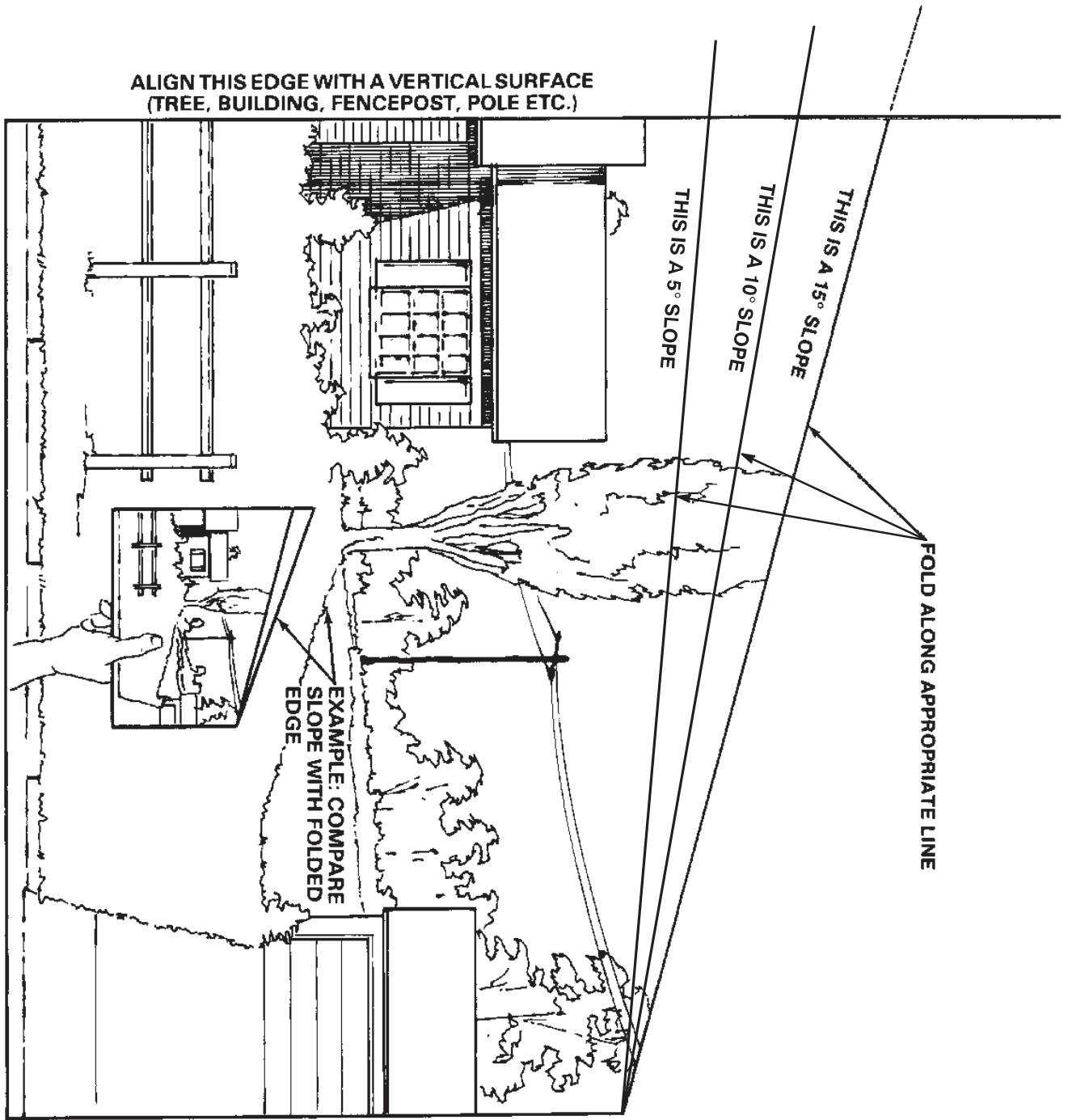





# Safety and Instruction Decals



Safety decals and instructions are easily visible to the operator and are located near any area of potential danger. Replace any decal that is damaged or lost.

**Top Of Console Under Seat  
(Part No. 103-0245)**

**MOTION CONTROL**

**CAUTION**

Mercury in tilt switch is poisonous and can cause severe illness.

- Never attempt to open or repair switch.
- Avoid contact with mercury.
- See operator's manual for disposal guide.

**WARNING**

Battery contains sulfuric acid. Avoid contact and always shield eyes, face, skin and clothing from battery. Cigarettes, flames or sparks could cause battery to explode. Do not charge or use booster cables or adjust post connections without proper training. In event of an accident flush with water and call a physician immediately. Keep out of reach of children.

103-0245

**DRIVE WHEEL RELEASE**

Use 5/8 wrench  
One turn counter-clockwise to release.  
Do not over-tighten.

**MOTION CONTROL**

## On Control Panel (Part No. 100-4311)

**DISENGAGE**

**ENGAGE**

**BRAKE**

**DANGER** TO AVOID SERIOUS INJURY OR DEATH:

- READ & UNDERSTAND THE OPERATOR'S MANUAL.
- USE SAFELY. MACHINE IS NOT A TOY.
- NEVER USE WHEN UNDER THE INFLUENCE OF ALCOHOL OR DRUGS.
- KNOW LOCATION AND FUNCTION OF CONTROLS.
- KEEP SAFETY SHIELDS IN PLACE AND WORKING.
- CHECK PERFORMANCE OF ALL INTERLOCK SWITCHES DAILY. DO NOT DEFEAT INTERLOCK SYSTEM. IT IS FOR YOUR PROTECTION.
- STOP ENGINE, SET PARKING BRAKE AND REMOVE KEY BEFORE LEAVING MACHINE.

FOR REPLACEMENT MANUAL, SEND MODEL & SERIAL NUMBER TO: THE TORO CO., 8111 LYNDALE AVE. S., BLOOMINGTON, MN 55420.

**THROTTLE**

**DANGER**

- NEVER CARRY CHILDREN OR OTHER PASSENGERS.
- LOOK DOWN AND BEHIND BEFORE AND WHILE BACKING UP.
- NEVER MOW WHEN CHILDREN, PEOPLE OR PETS ARE IN MOWING AREA.
- GO UP AND DOWN SLOPES, NOT ACROSS.
- IF MACHINE STOPS GOING UP HILL, STOP BLADE AND BACK SLOWLY DOWN.
- AVOID SHARP OR SUDDEN TURNS & SLIPPERY OR STEEP AREAS.
- AVOID BLADE UNLESS BLADE & ENGINE ARE STOPPED.
- REMOVE OBJECTS THAT COULD BE THROWN BY THE BLADE.
- THROWN OBJECTS OR BLADE CONTACT CAN CAUSE SERIOUS INJURY OR DEATH

**On Right Side Of Height-of-cut Plate  
(Part No 1-633345)**

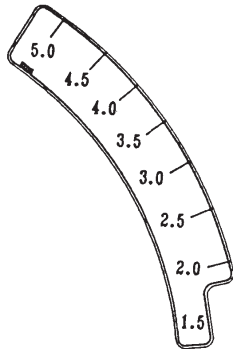

**On Left Side Of Height-of-cut Plate  
(Part No 1-633706)**

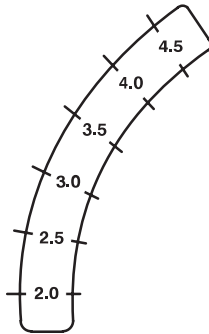

**On Left Side Gas Tank  
(Part No. 99-4612)**

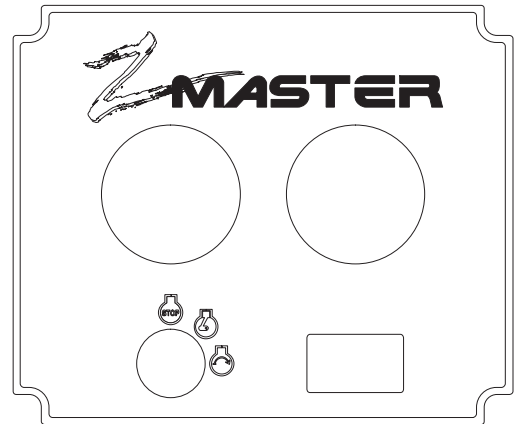

Below Center Of Console  
(Part No. 103-0262)

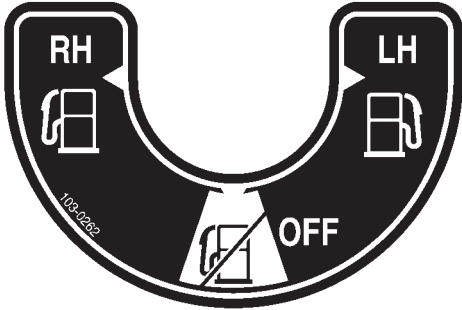

On Front Console  
(Part No. 98-4387)



On Rubber Flap Behind Seat  
(Part No. 103-0368)



Under Footrest  
(Part No. 1-633766)

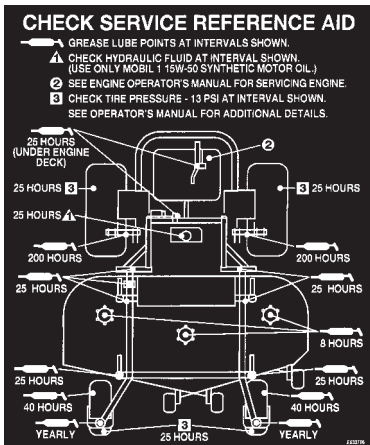

On Rubber Flap Behind Seat  
(Part No. 1-633462)

IMPORTANT:  
BEFORE STARTING ENGINE  
CLEAN GRASS FROM PUMP  
DRIVE BELT COMPARTMENT.  
CHECK MORE OFTEN IN DRY  
CONDITIONS

Under Footrest And (3) Near Deck  
Mower Spindles  
(Part No. 98-5954)



On Top Of Right Engine  
Baffle  
(Part No. 1-643339)

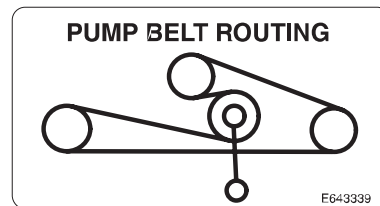

**On Top Of Hydraulic Reservoir  
(Part No. 1-523552)**



**On Hydraulic Reservoir Mounting Bracket  
(Part No. 1-513929)**

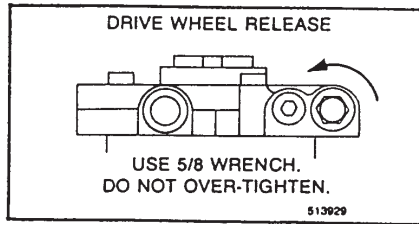

**On Tilt Switch  
(Part No. 1-643401)**



**On Radiator Fan Mounting Plate  
(Part No. E643253)**



**Under Hood on Radiator  
(Part No. 104-2449)**



**On Deck Support Frame  
(Part No. 1-633818)**

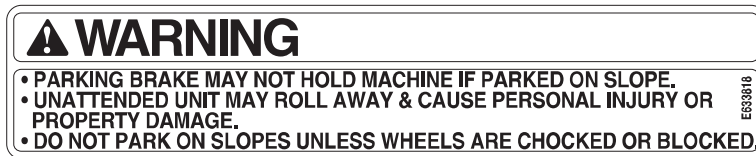

**On Z-Stand  
(Part No. 104-7759)**



**On Radiator Trim Plate  
(Part No. 65-2690)**



**On Right Side Of Mower  
(Part No. 66–1340)**



**On Deflector  
(Part No. 54–9220)**



**On Left Side Of Mower  
(Part No. 43–8480)**



**Next To Anti-scalp Roller  
(Part No. 98–3798)**

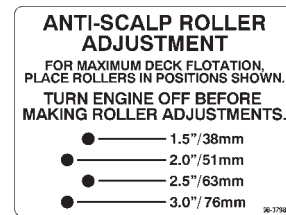

**(2) On Belt Covers  
(Part No. 67–5360)**



**On Left Front Of Mower  
(Part No. 93–7818)**

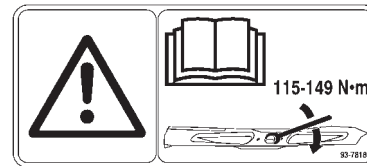

**On Top Center Of Mower  
(Part No. 99–4686)**

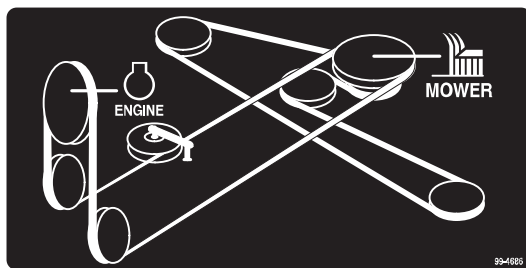

# Gasoline and Oil

## Recommended Gasoline

Use UNLEADED Regular Gasoline suitable for automotive use (85 pump octane minimum). Leaded regular gasoline may be used if unleaded regular is not available.

**Important** Never use methanol, gasoline containing methanol, or gasohol containing more than 10% ethanol because the fuel system could be damaged. Do not mix oil with gasoline.



### Danger



**In certain conditions, gasoline is extremely flammable and highly explosive. A fire or explosion from gasoline can burn you and others and can damage property.**

- **Fill the fuel tank outdoors, in an open area, when the engine is cold. Wipe up any gasoline that spills.**
- **Do not fill the fuel tank completely full. Add gasoline to the fuel tank until the level is 1/4" to 1/2" (6 mm to 13 mm) below the bottom of the filler neck. This empty space in the tank allows gasoline to expand.**
- **Never smoke when handling gasoline, and stay away from an open flame or where gasoline fumes may be ignited by a spark.**
- **Store gasoline in an approved container and keep it out of the reach of children. Never buy more than a 30-day supply of gasoline.**
- **Always place gasoline containers on the ground away from your vehicle before filling.**
- **Do not fill gasoline containers inside a vehicle or on a truck or trailer bed because interior carpets or plastic truck bed liners may insulate the container and slow the loss of any static charge.**
- **When practical, remove gas-powered equipment from the truck or trailer and refuel the equipment with its wheels on the ground.**
- **If this is not possible, then refuel such equipment on a truck or trailer from a portable container, rather than from a gasoline dispenser nozzle.**
- **If a gasoline dispenser nozzle must be used, keep the nozzle in contact with the rim of the fuel tank or container opening at all times until fueling is complete.**



### Warning



**Gasoline is harmful or fatal if swallowed. Long-term exposure to vapors can cause serious injury and illness.**

- **Avoid prolonged breathing of vapors.**
- **Keep face away from nozzle and gas tank or conditioner opening.**
- **Keep gas away from eyes and skin.**

## Using Stabilizer/Conditioner

Use a fuel stabilizer/conditioner in the machine to provide the following benefits:

- Keeps gasoline fresh during storage of 90 days or less. For longer storage it is recommended that the fuel tank be drained.
- Cleans the engine while it runs
- Eliminates gum-like varnish buildup in the fuel system, which causes hard starting

**Important** Do not use fuel additives containing methanol or ethanol.

Add the correct amount of gas stabilizer/conditioner to the gas.

**Note:** A fuel stabilizer/conditioner is most effective when mixed with fresh gasoline. To minimize the chance of varnish deposits in the fuel system, use fuel stabilizer at all times.

## Filling the Fuel Tank

1. Shut the engine off and set the parking brake.
2. Clean around each fuel tank cap and remove the cap. Add unleaded regular gasoline to both fuel tanks, until the level is 1/4 to 1/2 inch (6 mm to 13 mm) below the bottom of the filler neck. This space in the tank allows gasoline to expand. Do not fill the fuel tanks completely full.
3. Install fuel tank caps securely. Wipe up any gasoline that may have spilled.

## Check Engine Oil Level

Before you start the engine and use the machine, check the oil level in the engine crankcase; refer to Checking Oil Level, page 33.

# Assembly

## Loose Parts

**Note:** Use the chart below to verify all parts have been shipped.

DESCRIPTION	QTY.	USE
Rear Wheels	2	Install wheels to traction unit
Retaining rod	1	Install seat rod
Bolt 5/16–18 x 1" (26 mm)	1	
Locknut 5/16"	1	
Control lever–right	1	Install motion control levers
Control lever–left	1	
Bolt 3/8–1 x 1" (26 mm)	4	
Spring washer 3/8"	4	
Key	2	Read before operating machine
Operator's Manual	1	
Engine Operator's Manual	1	
Parts Catalog	1	
Registration card	1	
		Fill out and return to Toro

## Install Drive Wheels

1. Uncrate mower.
2. Remove wheel nuts from rear wheel hubs.
3. Align holes. Mount drive wheels with the valve stem to the outside of the traction unit.
4. Secure using wheel nuts provided. Torque to 95 ft–lbs (128 N•M).

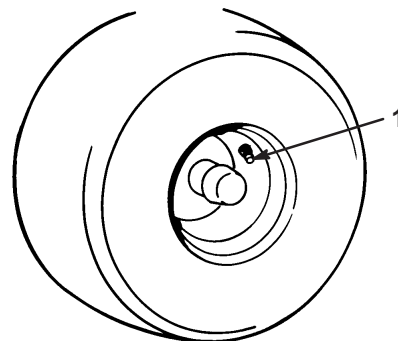

m-1872

**Figure 2**

1. Valve stem

## Tire Pressure

Check the air pressure in the front and rear tires (Fig. 2).

Pressure: 13 psi (90 kPa)

## Install Seat Retaining Rod

1. Tilt seat up. Remove 5/16" (8mm) locknut from bolt attaching seat retaining rod to seat frame (Fig. 3).

- Remove retaining rod from seat and insert the "L" shaped end of the rod into the hole directly above the left-side hydraulic pump (Fig. 3).
- Place the seat retaining rod to the outside of the mounting tab of the seat frame and secure with 5/16-18 x 1" (26 mm) bolt and 5/16" (8mm) locknut (Fig. 3).
- Tighten until snug, then loosen so the rod pivots freely.

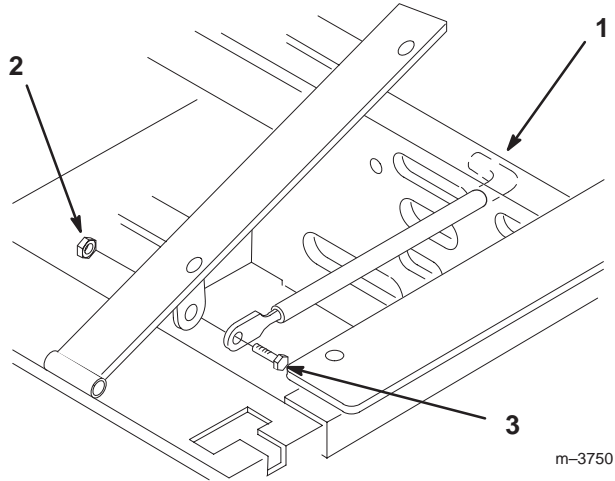
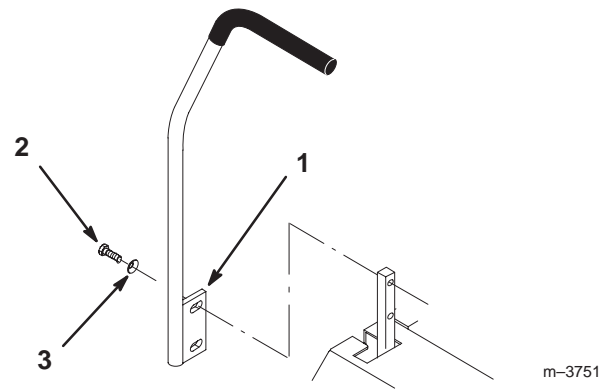

**Figure 3**

- L end of retaining rod
- Locknut 5/16"
- Bolt 5/16-18 x 1" (26 mm)

## Install Motion Control Levers

- Remove the (4) 3/8-16 x 1" (26 mm) bolts and (4) 3/8" spring washers which attach the motion control levers to the control arm shafts for shipping (Fig. 4).
- Place the levers (with the mounting plate toward the rear) on the outside of the control arm shaft and secure with (4) 3/8-16 x 1" (26 mm) bolts and (4) 3/8" spring washers (Fig. 4).
- Position the levers so the bolts are in the center of the slots on the lever mounting plate and tighten until snug.
- Align the front/rear position of the levers, with each other, in the neutral position. Loosen hardware and adjustment by sliding/tilting the lever(s) forward or backward until properly aligned (Fig. 4).



**Figure 4**

- Mounting plate
- Bolt 3/8-18 x 1" (26 mm)
- Spring washer 3/8"

- If the ends of the levers hit against each other, while in the drive position (Fig 5) (levers rotated in as far as possible) make adjustments by moving the levers outward to the neutral lock position and carefully bend them outward. Move them back to the drive position and check for clearance. Repeat if necessary.

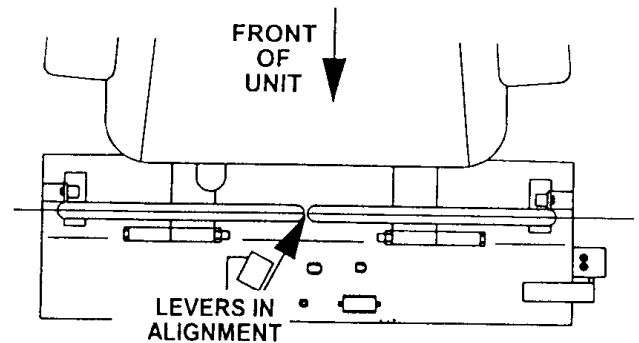

**Figure 5**

## Activate the Battery

Bulk electrolyte with 1.260 specific gravity must be purchased from a local battery supply outlet.

- Tilt seat up.
- First disconnect the negative battery cable and ground wire from the negative (-) battery terminal.
- Slide the red terminal boot off the positive (red) battery terminal. Then remove positive (red) battery cable.
- Remove battery hold down clamp.

**Important** Be careful not to damage the long vent tube when removing the battery box.

**Danger**

Battery electrolyte contains sulfuric acid which is a deadly poison and causes severe burns.

- Do not drink electrolyte and avoid contact with skin, eyes or clothing. Wear safety glasses to shield your eyes and rubber gloves to protect your hands.
- Fill the battery where clean water is always available for flushing the skin.
- Follow all instructions and comply with all safety messages on the electrolyte container.

5. Remove battery from machine.
6. Place battery on a level surface.
7. Remove filler caps from the battery. Slowly pour electrolyte into each cell until the electrolyte level is up to the lower part of the tube (Fig. 6).

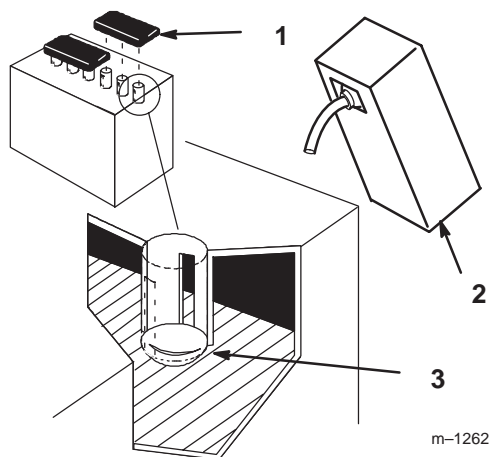

**Figure 6**

1. Filler caps
2. Electrolyte
3. Lower part of the tube

8. Leave the covers off and connect a 3 to 4 amp battery charger to the battery posts (Fig. 7). Charge the battery at a rate of 4 amperes or less for 4 hours (12 volts).

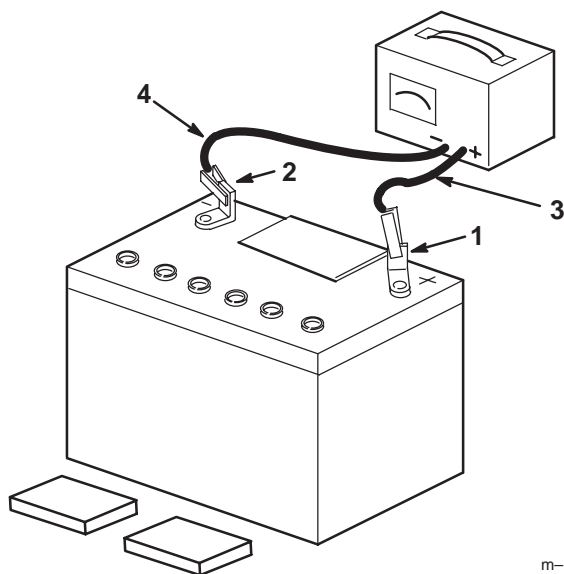

m-1254

**Figure 7**

1. Positive post
2. Negative post
3. Charger red (+) wire
4. Charger black (-) wire

**Warning**

Charging battery produces gasses that can explode and cause serious injury.

- Keep cigarettes, sparks and flames away from battery.
- Make sure the ignition switch is off.
- Ventilate when charging or using battery in an enclosed space.

9. When the battery is fully charged, disconnect the charger from the electrical outlet then from the negative and positive battery posts (Fig. 7).
10. Slowly pour electrolyte into each cell until the level is once again up to the lower part of the tube in the battery case and install covers (Fig. 6).
11. Wash off any spilled acid with water. Dry off the battery.

## Install Battery

1. Position battery in tray with terminal posts toward the engine (Fig. 8).
2. First, install the positive (red) battery cable to positive (+) battery terminal.
3. Then install negative battery cable and ground wire to the negative (-) battery terminal.



4. Secure cables with (2) 1/4 x 3/4" (19 mm) bolts 1/4" washers and 1/4" locknuts (Fig. 8).
5. Slide the red terminal boot onto the positive (red) battery post.
6. Secure battery with J-bolts, hold down clamp and (2) 1/4" washers and (2) 1/4" wing nuts (Fig. 8).
7. Position drain tube away from belts and other parts to prevent corrosion.

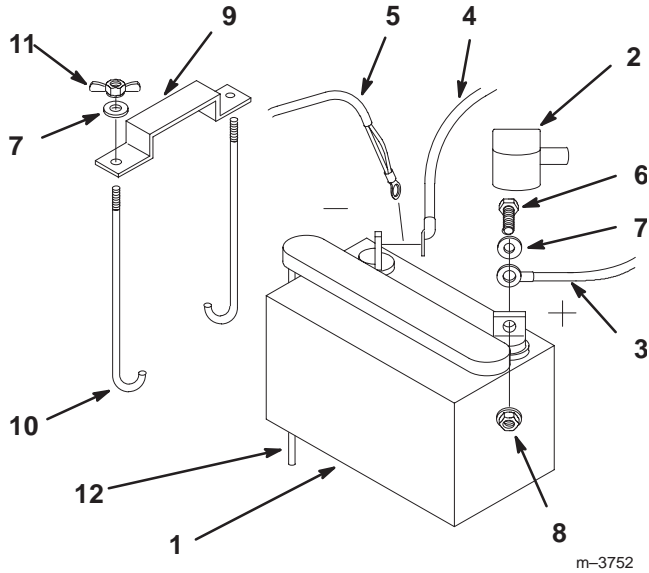

**Figure 8**

- |                               |                   |
|-------------------------------|-------------------|
| 1. Battery                    | 7. Washer 1/4"    |
| 2. Terminal boot              | 8. Locknut 1/4"   |
| 3. Positive battery cable     | 9. Battery clamp  |
| 4. Negative battery cable     | 10. J-bolts       |
| 5. Ground wire                | 11. Wing nut 1/4" |
| 6. Bolt 1/4-20 x 3/4" (19 mm) | 12. Drain Tube    |

## Check Engine Oil Level

Before you start the engine and use the machine, check the oil level in the engine crankcase; refer to Checking Oil Level, page 33.

## Check Side Discharge Chute

Remove plastic tie holding side discharge chute up and lower into place.

## Check the Leveling of Mower Deck

Check the level of the deck before the machine is first put in use.

Refer to Mower Leveling and Compression Spring Adjustment in the Maintenance section on page NO TAG.

## Cooling System

### Checking Radiator Coolant

! **Danger** !

**Discharge of hot pressurized coolant or touching hot radiator and surrounding parts can cause severe burns.**

- Do not remove the radiator cap when the engine is hot. Always allow the engine to cool at least 15 minutes or until the radiator cap is cool enough to touch without burning your hand before removing the radiator cap.
- Do not touch radiator and surrounding parts that are hot.

Check the cooling system level before engine is first started.

Fluid Type: 50/50 mix of permanent anti-freeze (ethylene glycol) and water.

Cooling System Capacity: 4 qt. (3.8 l)

! **Danger** !

**Rotating shaft and fan can cause personal injury.**

- Do not operate the machine without the covers in place.
- Keep fingers, hands and clothing clear of rotating fan and drive shaft.
- Shut off the engine and remove the ignition key before performing maintenance.

! **Caution** !

**Swallowing engine coolant can cause poisoning.**

- Do not swallow engine coolant.
- Keep out of reach from children and pets.

1. Position machine on a level surface, stop the engine and set the parking brake.
2. Tilt seat up and tilt engine hood forward.
3. With the engine cool, remove the radiator cap (Fig. 9).
4. If coolant level is low, add 50/50 mixture of permanent anti-freeze and water until completely full without overflowing.

5. Reinstall radiator cap. Completely seat cap by pushing down and turning until it stops.
6. Add 50/50 coolant mix to overflow bottle and fill to indicator line on the bottle, if required (Fig. 9).

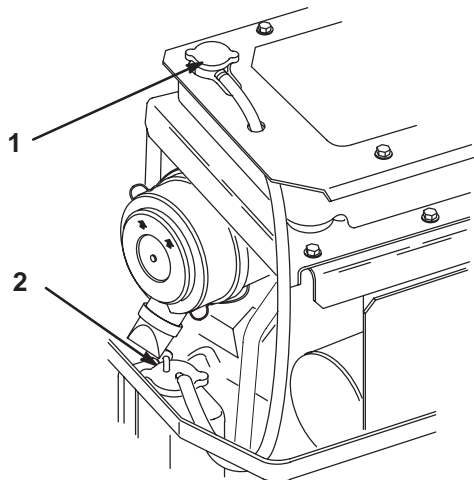

m-5031

**Figure 9**

1. Radiator Cap
2. Antifreeze Overflow Bottle

## Greasing the Bearings

**Make sure cutting unit spindles are full of grease before engine is first started.**

Grease with No. 2 general purpose lithium base or molybdenum base grease.

1. Grease the fittings on the three spindle bearings. Grease until it comes out lower seals (Fig. 10).

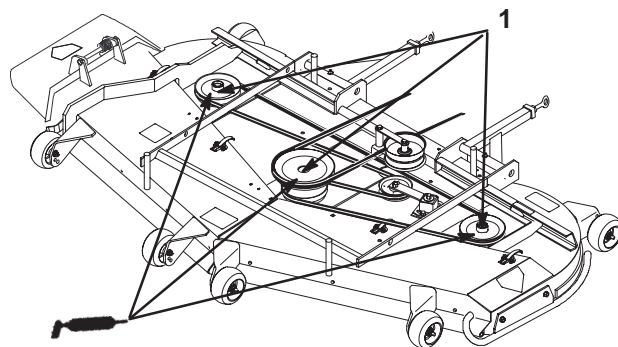

M-5036

**Figure 10**

1. Spindles

## Hydraulic System

### Checking the Hydraulic Fluid

Check the hydraulic fluid level before engine is first started.

Fluid Type: Mobil 1 15W-50 synthetic motor oil.

**Important** Use only oil specified. Other fluids could cause system damage.

Hydraulic System Oil Capacity: 2.1 qt. (2.0 l)

1. Position machine on a level surface and set the parking brake.
2. Clean area around filler neck of hydraulic tank (Fig. 11).
3. Remove cap from filler neck. Look inside to check if there is fluid in the reservoir (Fig. 11).
4. If there is no fluid, add fluid to reservoir approximately a 1/4" (6mm) below the top of baffle.
5. Run the machine 15 minutes to allow any air to purge out of the system.
6. Recheck level while fluid is warm. Add fluid to raise level to top of the baffle, if required.

**Note:** Fluid level should be to the top of the baffle when fluid is warm (Fig. 11).

7. Install cap on filler neck.

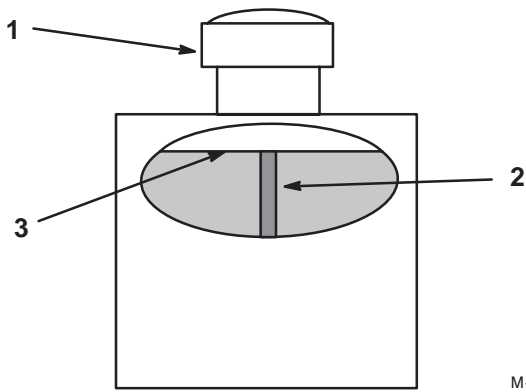

Figure 11

M-4280

1. Cap  
2. Baffle  
3. Fluid level-Full

! **Warning** !

**Hydraulic fluid escaping under pressure can penetrate skin and cause injury.**

- **If hydraulic fluid is injected into the skin it must be surgically removed within a few hours by a doctor familiar with this type of injury. Gangrene may result if this is not done.**
- **Keep body and hands away from pin hole leaks or nozzles that eject high pressure hydraulic fluid.**
- **Use cardboard or paper to find hydraulic leaks.**
- **Safely relieve all pressure in the hydraulic system before performing any work on the hydraulic system.**
- **Make sure all hydraulic fluid hoses and lines are in good condition and all hydraulic connections and fittings are tight before applying pressure to hydraulic system.**

# Operation

## Think Safety First

Please carefully read all the safety instructions on pages 3-8. Knowing this information could help you, your family, pets or bystanders avoid injury.

The use of protective equipment, such as but not limited to, for eyes, ears, feet and head is recommended.

! **Caution** !

**This machine produces sound levels in excess of 85dBA at the operators ear and can cause hearing loss through extended periods of exposure.**

**Wear hearing protection when operating this machine.**

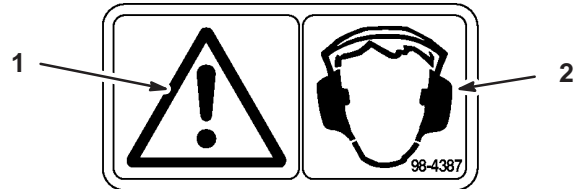

Figure 12

1. Caution  
2. Wear hearing protection

## Controls

Become familiar with all the controls (Fig. 13) before you start the engine and operate the machine.

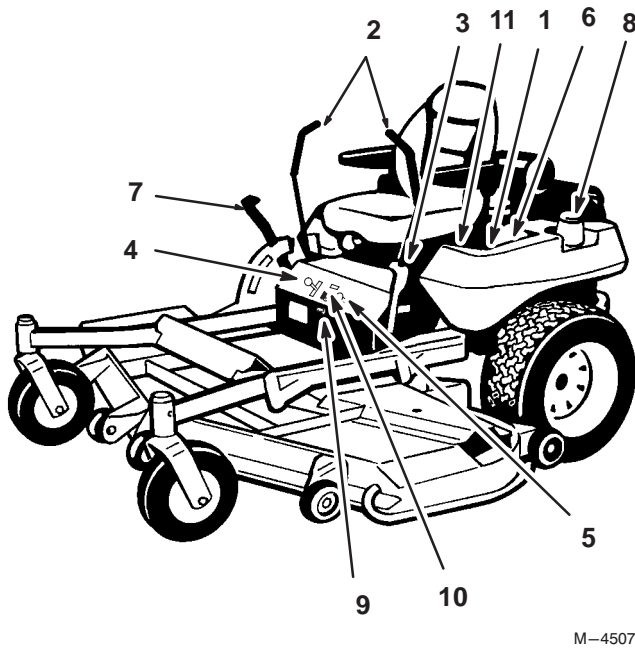

Figure 13

- |                         |                        |
|-------------------------|------------------------|
| 1. Ignition switch      | 7. Height-of-Cut lever |
| 2. Motion control lever | 8. Fuel cap            |
| 3. Parking brake lever  | 9. Fuel shut off lever |
| 4. Throttle             | 10. Hour meter         |
| 5. Choke                | 11. Temp Guage         |
| 6. Power take off (PTO) |                        |

## Parking Brake

Always set the parking brake when you stop the machine or leave it unattended.

### Setting the Parking Brake

1. Move the motion control levers (Fig. 13) out to the neutral lock position.
2. Pull back and up on the parking brake lever to set the parking brake (Fig. 14). The parking brake lever should stay firmly in the “ENGAGED” position.



### Warning



**Parking brake may not hold machine parked on a slope and could cause personal injury or property damage.**

**Do not park on slopes unless wheels are chocked or blocked**

## Releasing the Parking Brake

1. Push forward and down on the parking brake lever to release the parking brake (Fig. 14). The parking brake is “DISENGAGED” and the lever rests against the brake stop.

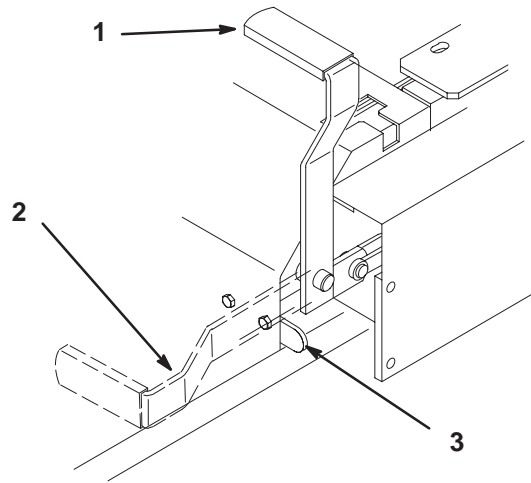

Figure 14

- |                      |               |
|----------------------|---------------|
| 1. Parking brake-ON  | 3. Brake Stop |
| 2. Parking brake-OFF |               |

## Starting and Stopping the Engine

### Starting

1. Sit on the seat and move the motion controls to neutral locked position.
2. Set the parking brake; refer to Setting the Parking Brake, page 20.
3. Move the PTO (power take off) switch to “OFF” (Fig. 15).
4. Move the choke control to “ON” position before starting a cold engine (Fig. 16).

**Note:** A warm or hot engine may not require choking. After engine starts, move choke control to “RUN” position.

5. Move the throttle control to the “FAST” position before starting a cold engine (Fig. 17).
6. Turn ignition key to “START” to energize starter. When engine starts, release key (Fig. 18).

**Important** Do not engage starter for more than 10 seconds at a time. If engine fails to start allow 30 second cool-down period between attempts. Failure to follow these instructions can burn out starter motor.

- After the engine starts, move the choke to “OFF” (Fig. 16). If the engine stalls or hesitates, move the choke back to “ON” for a few seconds. Then move the throttle lever to desired setting. Repeat this as required.

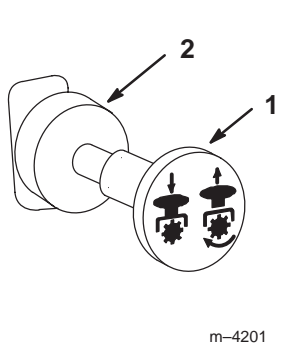

**Figure 15**

- PTO-On
- PTO-Off

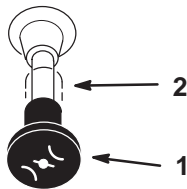

**Figure 16**

- Choke-On
- Choke-Off

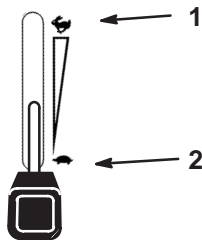

**Figure 17**

- Throttle-Fast
- Throttle-Slow

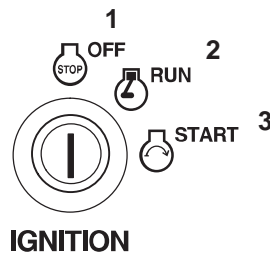

**Figure 18**

- Off
- Run
- Start

## Stopping

- Move the throttle lever to “SLOW” (Fig. 17).
- Turn the ignition key to “OFF” and remove (Fig. 18).

**Note:** If the engine has been working hard or is hot, let it idle for a minute before turning the ignition key “OFF.” This helps cool the engine before it is stopped. In an emergency, the engine may be stopped by turning the ignition key to “OFF.”

- Pull wire off spark plug(s) to prevent possibility of someone accidentally starting the machine before transporting or storing machine.

- Close fuel shut off valve, on front panel before transporting or storing machine.

**Important** Make sure fuel shut off valve is closed before transporting or storing machine, as fuel leakage may occur. Set parking brake before transporting. Make sure to remove key as fuel pump may run and cause battery to lose charge.

⚠
Caution
⚠

**Children or bystanders may be injured if they move or attempt to operate the tractor while it is unattended.**

**Always remove the ignition key and set the parking brake when leaving the machine unattended, even if just for a few minutes.**

## Operating the Power Take Off (PTO)

The power take off (PTO) switch engages and disengages power to the electric clutch.

### Engaging the PTO

- While seated in the seat, release pressure on the traction control levers and place in neutral.
- Place throttle to the fast position.
- Pull out on the power take off (PTO) switch to engage (Fig. 19).

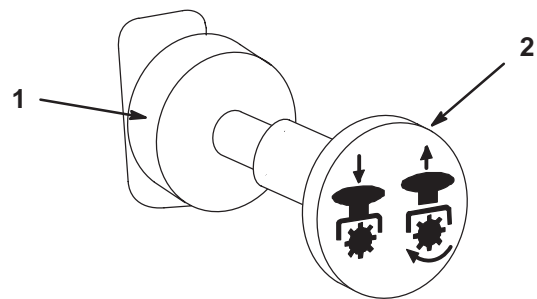



**Figure 19**

- PTO - Off
- PTO - On

### Disengaging the PTO

- To disengage push the PTO switch to the “OFF” position (Fig. 19).

# The Safety Interlock System

 **Caution** 

**If safety interlock switches are disconnected or damaged the machine could operate unexpectedly causing personal injury.**

- **Do not tamper with the interlock switches.**
- **Check the operation of the interlock switches daily and replace any damaged switches before operating the machine.**

## Understanding the Safety Interlock System

The safety interlock system is designed to prevent the engine from starting unless:

- You are sitting on the seat
- The parking brake is “ENGAGED”
- The power take off (PTO) is disengaged “OFF”
- The motion control levers are in neutral locked position

The safety interlock system also is designed to stop the engine when the traction controls are moved from the locked position with the parking brake “ENGAGED” or if you rise from the seat when the PTO is “ON” engaged.

## Testing the Safety Interlock System



Test the safety interlock system before you use the machine each time. If the safety system does not operate as described below, have an Authorized Service Dealer repair the safety system immediately.

1. Sitting on the seat, “ENGAGE” parking brake and move PTO “ON”. Try starting the engine; the engine should not crank.
2. Sitting on the seat, “ENGAGE” parking brake and move PTO “OFF”. Move either motion control lever (out of neutral locked position). Try starting the engine; the engine should not crank. Repeat for other control lever.
3. Sitting on the seat, “ENGAGE” parking brake, move PTO switch “OFF” and move the motion control levers to neutral lock position. Now start the engine. While the engine is running, release the parking brake, engage the PTO and rise slightly from the seat; the engine should stop.

4. Sitting on the seat, “ENGAGE” parking brake, move PTO switch “OFF” and move the motion control levers to neutral lock position. Now start the engine. While the engine is running, center either motion control and move (forward or reverse); the engine should stop. Repeat for other motion control.
5. Sitting on the seat, “DISENGAGE” parking brake, move PTO switch “OFF” and move the motion control levers to neutral lock position. Try starting the engine; the engine should not crank.

## Driving Forward or Backward

The throttle control regulates the engine speed as measured in rpm (revolutions per minute). Place the throttle control in the “FAST” position for best performance. Always operate in the full throttle position when mowing.

 **Caution** 

**Machine can spin very rapidly. Operator may lose control of machine and cause personal injury or damage to machine.**

- **Use caution when making turns.**
- **Slow the machine down before making sharp turns.**

## Forward

1. Release the parking brake; refer to Releasing the Parking Brake, page 20.
2. Move levers to the center, un-locked position.
3. To go forward, slowly push the motion control levers forward (Fig. 20).

**Note:** Engine will kill if traction control levers are moved with parking brake engaged.

To go straight, apply equal pressure to both motion control levers (Fig. 20).

To turn, move the motion control lever toward neutral in the direction you want to turn (Fig. 20).

The farther you move the traction control levers in either direction, the faster the machine will move in that direction.

To stop pull the motion control levers to neutral.

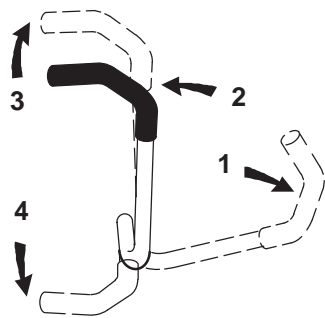

m-2715

**Figure 20**

- |   |             |
|---|-------------|
| 1. Motion control lever-neutral lock position | 3. Forward  |
| 2. Center un-lock position                    | 4. Backward |

## Backward

1. Move levers to the center, un-locked position.
2. To go backward, slowly pull the motion control levers rearward (Fig. 20).

To go straight, apply equal pressure to both motion control levers (Fig. 20).

To turn, release pressure on the motion control lever toward the direction you want to turn (Fig. 20).

To stop push the motion control levers to neutral.

## Stopping the Machine

To stop the machine, move the traction control levers to neutral and move to locked position, disengage the power take off (PTO), and turn the ignition key to "OFF". Also set the parking brake when you leave the machine; refer to Setting the Parking Brake, page 20. Remember to remove the key from the ignition switch.



### Caution



**Children or bystanders may be injured if they move or attempt to operate the tractor while it is unattended.**

**Always remove the ignition key and set the parking brake when leaving the machine unattended, even if just for a few minutes.**

## Instruments

### Hour Meter

The hour meter records the number of hours the engine has operated. It operates when the engine is running. Use these times for scheduling regular maintenance.

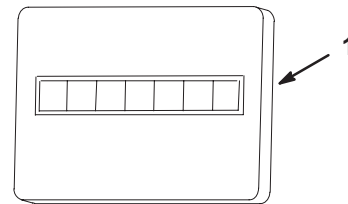

m-3077

**Figure 21**

1. Hour meter

## Fuel Tanks

The unit has two fuel tanks, one located on the left side and on the right side. Each tank connects to the fuel shut off valve in the control panel. From there a common fuel line leads to the engine (Fig. 22).

To use the right side fuel tank rotate the fuel shut off valve 1/4 turn to the right from the off location. This uses fuel from the right side tank only. When the right hand fuel tank is empty, move the fuel shut off valve 1/4 turn to the left from the off position.

Close fuel shut off valve, on front panel before transporting or storing machine.

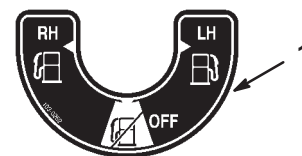

**Figure 22**

1. Shut off valve

## Adjusting Height-of-Cut

The height-of-cut is adjusted from 1-1/2" to 5" (38 to 127 mm) in 1/4" (6 mm) increments by relocating clevis pin in different hole locations.

1. Raise the height-of-cut lever to the transport position (also the 5" (127 mm) cutting height position) (Fig. 23).
2. To adjust, remove hairpin cotter and clevis pin from height-of-cut bracket (Fig. 23).

3. Select hole in height-of-cut bracket corresponding to the height-of-cut desired, and insert clevis pin (Fig. 23).
4. Secure clevis pin with hairpin cotter (Fig. 23).
5. Move lever to selected height.

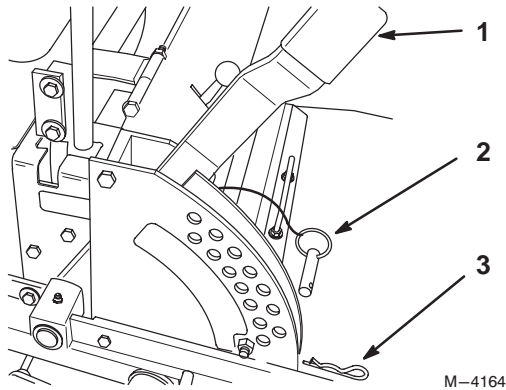

**Figure 23**

1. Height of cut lever
2. Clevis Pin
3. Hairpin Cotter

## Adjusting Anti-Scalp Rollers

Whenever you change the height-of-cut it is recommended to adjust the height of the anti-scalp rollers.

1. Disengage the power take off (PTO) and turn the ignition key to "OFF" to stop the engine. Move levers to neutral locked position and apply parking brake. Remove the key.

2. After adjusting height-of-cut remove flange nut and spring disk while holding stud with wrench (Fig. 24).

**Note:** Do not remove the wheel nut and washer (Fig. 24).

3. Select hole so gage wheel is positioned to the nearest corresponding height-of-cut desired (Fig. 24).
4. Reinstall the flange nut and spring disk (Fig. 24).
5. Repeat adjustment on other gage wheels.

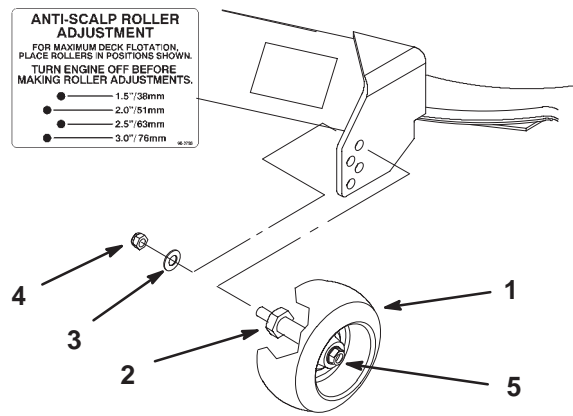

m-4167

**Figure 24**

1. Gage Wheel
2. Stud
3. Spring Disk
4. Flange Nut
5. Wheel nut and washer. Do Not Remove.

## Positioning the Seat

The seat can move forward and backward. Position the seat where you have the best control of the machine and are most comfortable.

1. To adjust, move the lever sideways to unlock seat (Fig. 25).
2. Slide the seat to the desired position and release lever to lock in position.

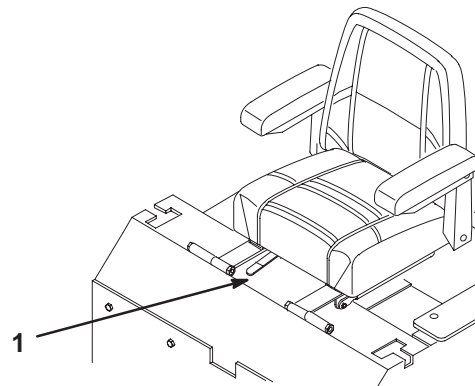

m-3655

**Figure 25**

1. Adjustment lever

## Pushing the Machine by Hand

**Important** Always push the machine by hand. Never tow the machine because hydraulic damage may occur.



## To Push the Machine

1. Disengage the power take off (PTO) and turn the ignition key to “OFF” to stop the engine. Move levers to neutral locked position and apply parking brake.
2. Rotate the by-pass valves counterclockwise 1 turn to push. This allows hydraulic fluid to by-pass the pump enabling the wheels to turn (Fig. 26).

**Important** Do not rotate by-pass valves more than 1 turn. This prevents valves from coming out of the body and causing fluid to run out.

3. Disengage parking brake before pushing.

## To Operate the Machine

1. Rotate the by-pass valves clockwise 1 turn to operate machine (Fig. 26).

**Note:** The machine will not drive unless by-pass valves are turned in.

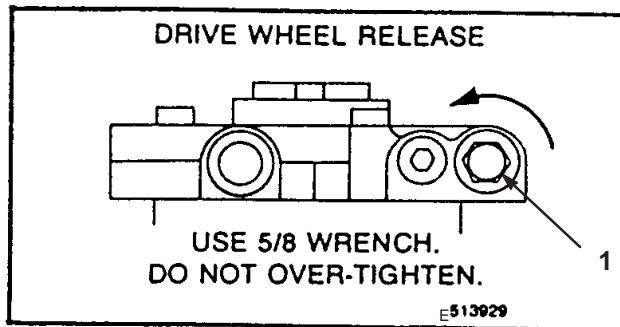

Figure 26

1. By-pass valve

## Transporting Machines

Use a heavy-duty trailer or truck to transport the machine. Ensure that the trailer or truck has all necessary lighting and marking as required by law. Please carefully read all the safety instructions on pages 3–13. Knowing this information could help you, your family, pets or bystanders avoid injury.

To transport the machine:

- Lock brake and block wheels.
- Securely fasten the machine to the trailer or truck with straps, chains, cable, or ropes.
- Secure a trailer to towing vehicle with safety chains.

⚠Warning⚠

**Driving on street or roadway without turn signals, lights, reflective markings, or a slow moving vehicle emblem is dangerous and can lead to accidents causing personal injury.**

**Do not drive machine on a public street or roadway.**

## Loading Machines

Use extreme caution when loading units on trailers or trucks. One full width ramp that is wide enough to extend beyond the rear tires is recommended instead of individual ramps for each side of the unit. The lower rear section of the tractor frame extends back between the rear wheels and serves as a stop for tipping backward. Having a full width ramp provides a surface for the frame members to contact if the unit starts to tip backward. If it is not possible to use one full width ramp, use enough individual ramps to simulate a full width continuous ramp.

Ramp should be long enough so that the angles between the ramp and the ground and the ramp and the trailer or truck do not exceed 15 degrees. A steeper angle may cause mower deck components to get caught as the unit moves from ramp to trailer or truck. Steeper angles may also cause the unit to tip backward. If loading on or near a slope, position the trailer or truck so it is on the down side of the slope and the ramp extends up the slope. This will minimize the ramp angle. The trailer or truck should be as level as possible.

**Important** DO NOT attempt to turn the unit while on the ramp; you may lose control and drive off the side.

Avoid sudden acceleration when driving up a ramp and sudden deceleration when backing down a ramp. Both maneuvers can cause the unit to tip backward.



## Warning



Loading a unit onto a trailer or truck increases the possibility of backward tip-over and could cause serious injury or death.

- Use extreme caution when operating a unit on a ramp.
- Use only a single, full width ramp; DO NOT use individual ramps for each side of the unit.
- If individual ramps must be used, use enough ramps to create an unbroken ramp surface wider than the unit.
- Do not exceed a 15 degree angle between ramp and ground or between ramp and trailer or truck.
- Avoid sudden acceleration while driving unit up a ramp to avoid tipping backward.
- Avoid sudden deceleration while backing unit down a ramp to avoid tipping backward.

## Using the Lift Assist Lever

The lift assist lever is used for raising the deck along with the height-of-cut lever. This allows for easier raising of the deck.

1. Place your foot onto lift assist lever.
2. Press on lift assist while pulling up on height-of-cut lever (Fig. 27).

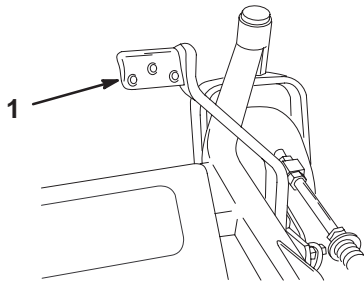

m-5028

Figure 27

1. Lift Assist Lever

## Using the Z-Stand™

The Z-Stand is used for raising the front end of the machine. This allows for cleaning of the deck and removal of the blades.



## Warning



Unit could fall onto someone and cause serious injury or death.

- Use extreme caution when operating unit on Z-Stand.
- Use only for cleaning deck and removing blades.
- Do not keep unit on Z-Stand for extended periods of time.
- Always shut engine off and set parking brake before performing any maintenance to deck.

## Driving up onto the Z-Stand

1. Raise deck to transport position.
2. Raise latch. Lift stand foot and twist out of its rest position (Fig. 28).

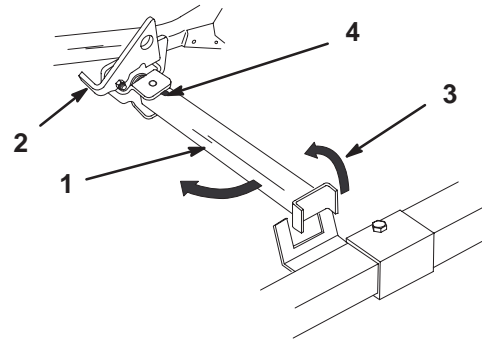

m-5022

Figure 28

1. Z-Stand (rest position)
2. Latch
3. Raise up and twist
4. Bottom of slot

3. Swing stand foot out front and slide stand toward machine, into the bottom of slot (Fig. 28).

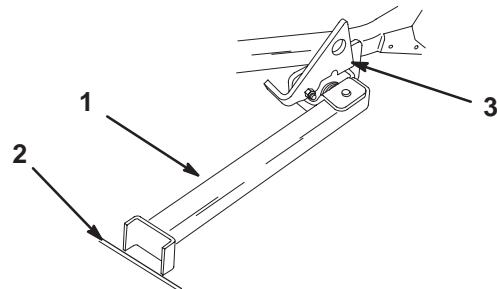

m-5023

Figure 29

1. Z-Stand (Positioned in slot)
2. Crack in side walk or turf
3. Latch resting on pivot tab

4. Set foot of stand on ground and rest latch on pivot tab (Fig. 29).

5. Start engine and put at half throttle.

**Note:** For best results, place foot of stand into seams in sidewalks or into turf (Fig. 29).

6. Drive onto stand. Stop when latch drops over tab into locked position (Fig. 30). Once onto stand, engage parking brake. Shut off engine.
7. Chock or block the drive wheels.

! **Warning** !

**Parking brake may not hold machine parked on Z-Stand and could cause personal injury or property damage.**

**Do not park on Z-Stand unless wheels are chocked or blocked.**

8. Perform maintenance.

## Driving off the Z-Stand

1. Raise latch to unlocked position (Fig. 30).
2. Start engine and place at half throttle. Disengage parking brake.
3. Slowly drive backwards off of stand.
4. Return stand to its rest position (Fig. 28).

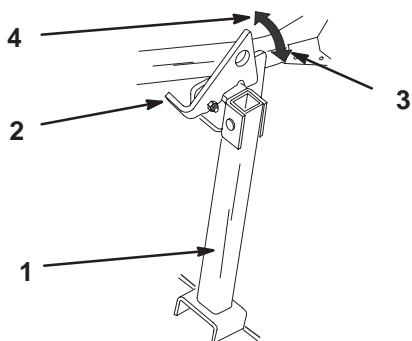

m-5026

**Figure 30**

- |            |                      |
|------------|----------------------|
| 1. Z-Stand | 3. Locked position   |
| 2. Latch   | 4. Unlocked position |

## Tips for Mowing Grass

### Fast Throttle Setting

For best mowing and maximum air circulation, operate the engine at "FAST." Air is required to thoroughly cut grass clippings, so do not set the height-of-cut so low as to totally surround the mower by uncut grass. Always try to have one side of the mower free from uncut grass, which allows air to be drawn into the mower.

## Cutting a Lawn for the First Time

Cut grass slightly longer than normal to ensure the cutting height of the mower does not scalp any uneven ground. However, the cutting height used in the past is generally the best one to use. When cutting grass longer than six inches tall, you may want to cut the lawn twice to ensure an acceptable quality of cut.

### Cut 1/3 of the Grass Blade

It is best to cut only about 1/3 of the grass blade. Cutting more than that is not recommended unless grass is sparse, or it is late fall when grass grows more slowly.

### Mowing Direction

Alternate mowing direction to keep the grass standing straight. This also helps disperse clippings which enhances decomposition and fertilization.

### Mow at Correct Intervals

Normally, mow every four days. But remember, grass grows at different rates at different times. So to maintain the same cutting height, which is a good practice, mow more often in early spring. As the grass growth rate slows in mid summer, mow less frequently. If you cannot mow for an extended period, first mow at a high cutting height; then mow again two days later at a lower height setting.

### Cutting Speed

To improve cut quality, use a slower ground speed in certain conditions.

### Avoid Cutting Too Low

If the cutting width of the mower is wider than the mower you previously used, raise the cutting height to ensure that uneven turf is not cut too short.

### Long Grass

If the grass is ever allowed to grow slightly longer than normal, or if it contains a high degree of moisture, raise the cutting height higher than usual and cut the grass at this setting. Then cut the grass again using the lower, normal setting.

### When Stopping

If the machine's forward motion must be stopped while mowing, a clump of grass clippings may drop onto your lawn. To avoid this, move onto a previously cut area with the blades "ENGAGED".

## **Keep the Underside of the Mower Clean**

Clean clippings and dirt from the underside of the mower after each use. If grass and dirt build up inside the mower, cutting quality will eventually become unsatisfactory.

## **Blade Maintenance**

Maintain a sharp blade throughout the cutting season because a sharp blade cuts cleanly without tearing or shredding the grass blades. Tearing and shredding turns grass brown at the edges, which slows growth and increases the chance of disease. Check the cutter blades daily for sharpness, and for any wear or damage. File down any nicks and sharpen the blades as necessary. If a blade is damaged or worn, replace it immediately with a genuine TORO replacement blade.

# Maintenance

## Recommended Maintenance Schedule

Maintenance Service Interval	Maintenance Procedure
After first use	<ul style="list-style-type: none"> <li>Hydraulic fluid—check level</li> <li>Engine Oil—change</li> <li>Hydraulic filter—change</li> </ul>
Each Use	<ul style="list-style-type: none"> <li>Engine Oil—check level</li> <li>Safety System—check</li> <li>Mower Housing—clean</li> <li>Engine Coolant—check</li> <li>Engine Cooling System—clean<sup>1</sup></li> </ul>
Every 5 Hours	<ul style="list-style-type: none"> <li>Cutting Blades—check</li> <li>Blade Spindle Bearings—grease</li> </ul>
Every 25 Hours	<ul style="list-style-type: none"> <li>Hydraulic fluid—check level</li> <li>Chassis—grease<sup>1</sup></li> <li>Linkage bushings—oil<sup>1</sup></li> <li>Battery—check electrolyte</li> </ul>
Every 50 Hours	<ul style="list-style-type: none"> <li>Air Cleaner—service<sup>1</sup></li> <li>Belts—check for wear/cracks</li> <li>Tires—check pressure</li> <li>Service the spark arrester</li> </ul>
Every 100 Hours	<ul style="list-style-type: none"> <li>Paper Air Cleaner—replace<sup>1</sup></li> <li>Spark Plug(s)—change</li> <li>Hydraulic lines—check</li> <li>Engine Oil—change<sup>1</sup></li> <li>Fuel System—check</li> <li>Cooling System Hoses—check</li> </ul>
Every 200 Hours	<ul style="list-style-type: none"> <li>Oil Filter—change (200 hours or every other oil change)<sup>1</sup></li> <li>Fuel Filter—replace</li> <li>Engine Cooling System—check</li> <li>Hydraulic Filter—replace</li> </ul>
Every 400 Hours	<ul style="list-style-type: none"> <li>Engine Coolant—change</li> </ul>
Every 500 Hours or at Storage	<ul style="list-style-type: none"> <li>Castor Pivot — adjustment</li> <li>Wheel Hub Slotted Nut — adjustment</li> </ul>
Before Storage Service	<ul style="list-style-type: none"> <li>Battery—charge, Disconnect cables</li> <li>Gasoline—drain</li> <li>Chipped Surfaces—paint</li> <li>Perform all maintenance procedures listed above before storage</li> </ul>

<sup>1</sup>More often in dusty, dirty conditions



## Caution



If you leave the key in the ignition switch, someone could accidentally start the engine and seriously injure you or other bystanders.

Remove the key from the ignition and disconnect the wire from the spark plug(s) before you do any maintenance. Set the wire aside so that it does not accidentally contact the spark plug.

## Cutting Blades

Maintain sharp blades throughout the cutting season because sharp blades cut cleanly without tearing or shredding the grass blades. Tearing and shredding turns grass brown at the edges, which slows growth and increases the chance of disease.

Check the cutter blades daily for sharpness, and for any wear or damage. File down any nicks and sharpen the blades as necessary. If a blade is damaged or worn, replace it immediately with a genuine TORO replacement blade. For convenient sharpening and replacement, you may want to keep extra blades on hand.

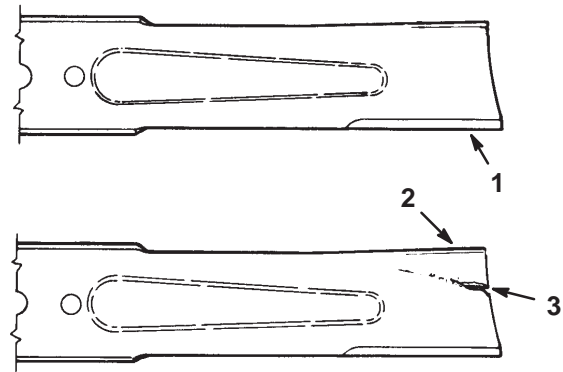

m-151

Figure 31

1. Cutting Edge
2. Curved Area
3. Wear/slot Forming



## Danger



A worn or damaged blade can break, and a piece of the blade could be thrown into the operator's or bystander's area, resulting in serious personal injury or death.

- Inspect the blade periodically for wear or damage.
- Replace a worn or damaged blade.

## Before Inspecting or Servicing the Blades

Disengage the blade control (PTO) and set the parking brake. Turn the ignition key to "OFF" to stop the engine. Remove the key and disconnect the spark plug wire(s) from the spark plug(s).

## Inspecting the Blades

1. Inspect the cutting edges (Fig 31). If the edges are not sharp or have nicks, remove and sharpen the blades. Refer to Sharpening the Blades on page 31.
2. Inspect the blades, especially the curved area (Fig. 31). If you notice any damage, wear, or a slot forming in this area (item 3 in Fig. 31), immediately install a new blade.

## Checking for Bent Blades

1. Rotate the blades until the ends face forward and backward (Fig. 32). Measure from a level surface to the cutting edge of the blades (Fig. 33). Note this dimension.

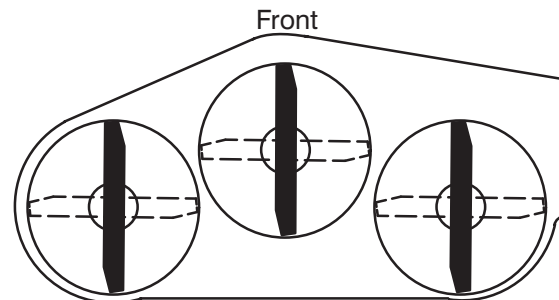

m-1078

Figure 32

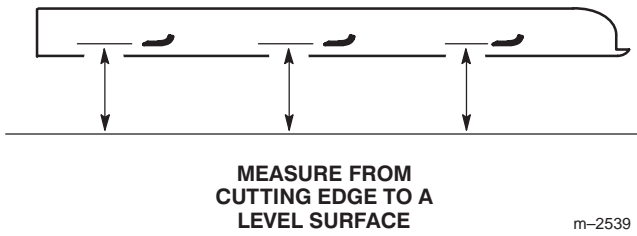

**Figure 33**

m-2539

2. Rotate the opposite ends of the blades forward. Measure from a level surface to the cutting edge of the blades at the same position as in step 1 above. The difference between the dimensions obtained in steps 1 and 2 must not exceed 1/8" (3 mm). If this dimension exceeds 1/8" (3 mm), the blade is bent and must be replaced. Refer to Removing the Blades, and Installing the Blades on page 31.

**Warning**

**A blade that is bent or damaged could break apart and could seriously injure or kill you or bystanders.**

- Always replace bent or damaged blade with a new blade.
- Never file or create sharp notches in the edges or surfaces of blade.

## Removing the Blades

Blades must be replaced if a solid object is hit, if the blade is out of balance or is bent. To ensure optimum performance and continued safety conformance of the machine, use genuine TORO replacement blades. Replacement blades made by other manufacturers may result in non-conformance with safety standards.

**Warning**

**Contact with sharp blade can cause serious injury.**

**Wear gloves or wrap sharp edges of the blade with a rag.**

1. Hold the blade end using a rag or thickly-padded glove. Remove the blade bolt, spring disk and blade from the spindle shaft (Fig. 36).

## Sharpening the Blades

**Warning**

**When sharpening blade, pieces of blade could be thrown and cause serious injury.**

**Wear proper eye protection when sharpening blade.**

1. Use a file to sharpen the cutting edge at both ends of the blade (Fig. 34). Maintain the original angle. The blade retains its balance if the same amount of material is removed from both cutting edges.

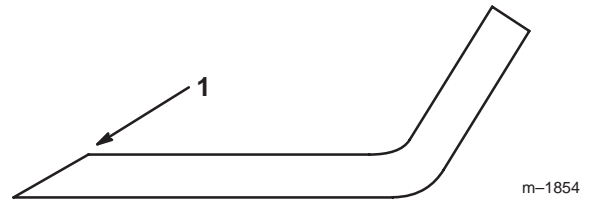

**Figure 34**

1. Sharpen at original angle

2. Check the balance of the blade by putting it on a blade balancer (Fig. 35). If the blade stays in a horizontal position, the blade is balanced and can be used. If the blade is not balanced, file some metal off the end of the sail area only (Fig. 36). Repeat this procedure until the blade is balanced.

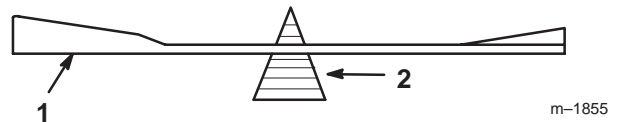

**Figure 35**

1. Blade
2. Balancer

## Installing the Blades

1. Install the blade onto the spindle shaft (Fig. 36).

**Important** The curved part of the blade must be pointing upward toward the inside of the mower to ensure proper cutting.

2. Install the spring disk and blade bolt. The spring disk cone must be installed toward the bolt head. (Fig. 36). **Torque the blade bolt to 85–110 ft-lb (115–150 N•m).**

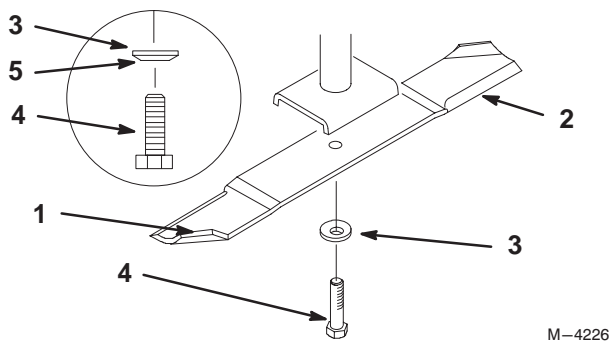

**Figure 36**

M-4226

- |                       |                           |
|-----------------------|---------------------------|
| 1. Sail Area of Blade | 4. Blade Bolt             |
| 2. Blade              | 5. Cone Towards Bolt Head |
| 3. Spring Disk        |                           |

## Air Cleaner

Paper Element:

- Clean after 50 operating hours.
- Replace after 300 operating hours.

**Note:** Service the air cleaner more frequently (every few hours) if operating conditions are extremely dusty or sandy.

### Removing Paper Element

1. Disengage the power take off (PTO), set the parking brake, and turn the ignition key to “OFF” to stop the engine. Remove the key.
2. Tilt seat up and tilt engine cover forward.
3. Clean around the air cleaner to prevent dirt from getting into the engine and causing damage. Loosen retaining clips and remove air cleaner cover (Fig. 37).

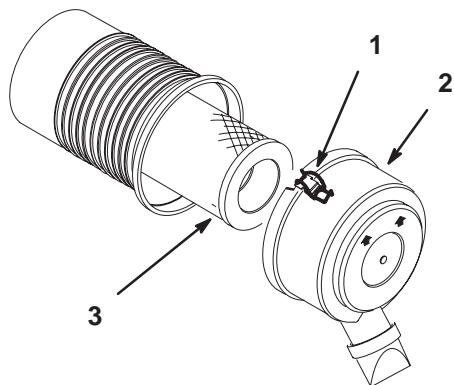

**Figure 37**

M-4382

- |                      |               |
|----------------------|---------------|
| 1. Retaining Clip    | 3. Air Filter |
| 2. Air cleaner cover |               |

4. Carefully remove filter from compartment (Fig. 37).

## Cleaning Paper Elements

### 1. Paper Element

- A. Lightly tap the element on a flat surface to remove dust and dirt (Fig. 38).
- B. Inspect the element for tears, an oily film, and damage to the rubber seal.

**Important** Never clean the paper element with pressurized air or liquids, such as solvent, gas, or kerosene. Replace the paper element if it is damaged, or cannot be cleaned thoroughly.

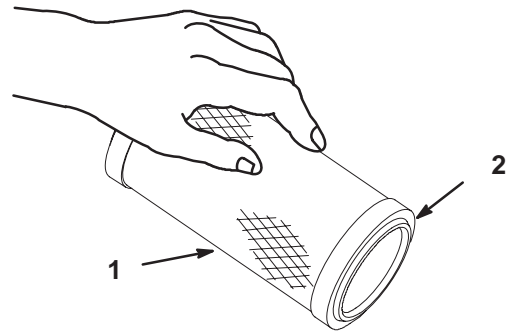

**Figure 38**

M-4383

- |                  |                |
|------------------|----------------|
| 1. Paper element | 2. Rubber seal |
|------------------|----------------|

## Installing Paper Elements

**Important** To prevent engine damage, always operate the engine with the paper air cleaner installed.

1. Carefully slide the element into the compartment (Fig. 37).
2. Place the air cleaner cover onto compartment and latch retaining clips (Fig. 37).

## Engine Oil

Change oil:

- After the first 8 operating hours.
- After every 100 operating hours.

**Note:** Change oil more frequently when operating conditions are extremely dusty or sandy.

Oil Type: Detergent oil (API service SG or SH)

Crankcase Capacity:

- 2.1 qt. (2.0 l) – When oil filter is removed.
- 1.9 qt. (1.8 l) – When oil filter is **not** removed.



Viscosity: See table below

### USE THESE SAE VISCOSITY OILS

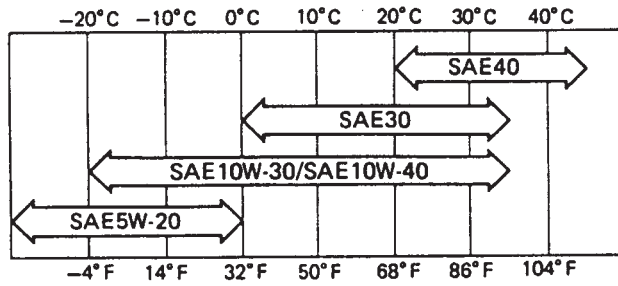

m-4292

## Checking Oil Level

**Note:** Check oil when engine is cold.

1. Disengage the power take off (PTO) and turn the ignition key to “OFF” to stop the engine. Move levers to neutral locked position and apply parking brake. Remove the key.
2. Clean around the oil dipstick so dirt cannot fall into the filler hole and damage the engine (Fig. 39).
3. Pull the oil dipstick out and wipe the metal end clean (Fig. 39).
4. Slide the oil dipstick fully into the filler cap. Pull the dipstick out and look at the metal end (Fig. 39). If oil level is low, slowly pour only enough oil into the filler tube to raise the level to the “FULL” mark.

**Important** Do not overfill the crankcase with oil because the engine may be damaged. Do not run engine with oil below the low mark because the engine may be damaged.

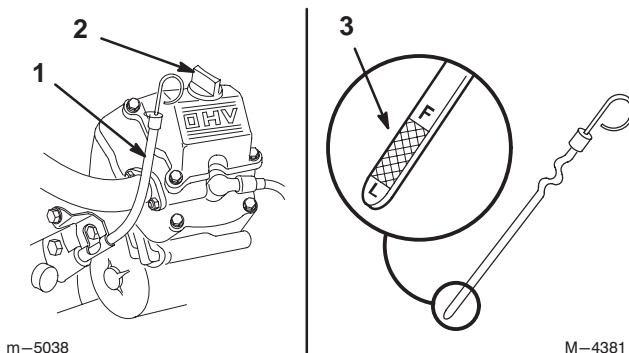

Figure 39

1. Oil dipstick
2. Filler cap
3. Metal end

## Changing/Draining Oil

Replace the oil every 100 hours.

1. Start the engine and let it run five minutes. This warms the oil so it drains better.
2. Park the machine so that the drain side is slightly lower than the opposite side to assure the oil drains completely. Disengage the power take off (PTO), set the parking brake, and turn the ignition key to “OFF” to stop the engine. Remove the key.
3. Place a pan below the oil drain. Rotate oil drain valve to allow oil to drain (Fig. 40).
4. When oil has drained completely, close the drain valve.

**Note:** Dispose of the used oil at a certified recycling center.

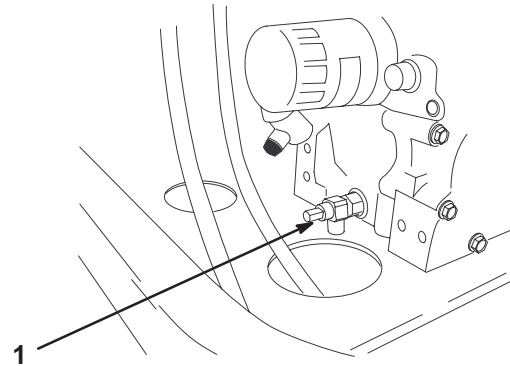

m-5030

Figure 40

1. Oil drain

5. Slowly pour approximately 80% of the specified amount of oil, page 32, into the filler tube (Fig. 39). Now check the oil level; refer to Checking Oil Level, page 33. Slowly add additional oil to bring to “FULL” mark on dipstick.

## Change Oil Filter

Replace the oil filter every 200 hours or every other oil change.

**Note:** Change oil filter more frequently when operating conditions are extremely dusty or sandy.

1. Drain the oil from the engine; refer to Changing/Draining Oil, page 33.
2. Remove the old filter and wipe the filter adapter (Fig. 41) gasket surface.
3. Pour new oil of the proper type in through the center hole. Stop pouring when the oil reaches the bottom of the threads. Allow a minute or two for the oil to be absorbed by filter material.
4. Apply a thin coat of new oil to the rubber gasket on the replacement filter (Fig. 41).

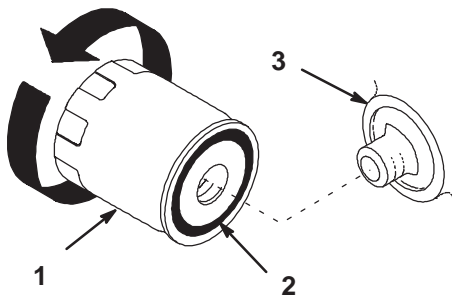

m-1256

**Figure 41**

1. Oil filter
2. Gasket
3. Adapter

5. Install the replacement oil filter to the filter adapter. Turn the oil filter clockwise until the rubber gasket contacts the filter adapter, then tighten the filter an additional 1/2 turn (Fig. 41).
6. Fill the crankcase with the proper type of new oil; refer to Changing/Draining Oil, page 33.

## Cooling System

### Checking Radiator Coolant



#### Danger



**Discharge of hot pressurized coolant or touching hot radiator and surrounding parts can cause severe burns.**

- Do not remove the radiator cap when the engine is hot. Always allow the engine to cool at least 15 minutes or until the radiator cap is cool enough to touch without burning your hand before removing the radiator cap.
- Do not touch radiator and surrounding parts that are hot.

Check the cooling system level daily.

Fluid Type: 50/50 mix of permanent antifreeze (ethylene glycol) and water.

Cooling System Capacity: 4.0 qt. (3.8 l)



#### Danger



**Rotating shaft and fan can cause personal injury.**

- Do not operate the machine without the covers in place.
- Keep fingers, hands and clothing clear of rotating fan and drive shaft.
- Shut off the engine and remove the ignition key before performing maintenance.



#### Caution



**Swallowing engine coolant can cause poisoning.**

- Do not swallow engine coolant.
- Keep out of reach from children and pets.

1. Position machine on a level surface, stop the engine and set the parking brake.
2. Tilt seat up and tilt engine hood forward.
3. With the engine cool, remove the radiator cap (Fig. 42).

4. If coolant level is low, add 50/50 mixture of permanent antifreeze and water until completely full without overflowing.
5. Reinstall radiator cap. Completely seat cap by pushing down and turning until it stops.
6. Add 50/50 coolant mix to overflow bottle and fill to indicator line on the bottle, if required (Fig. 42).

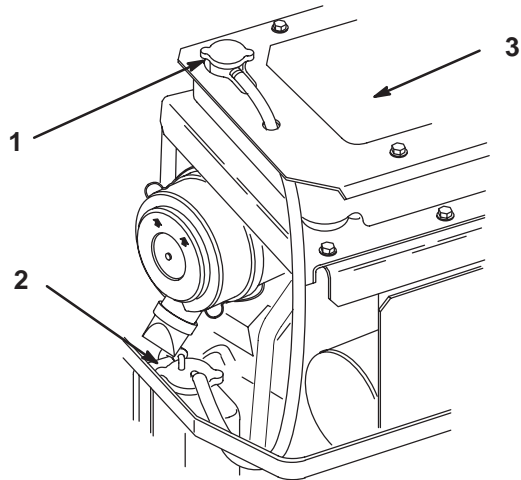

m-5031

**Figure 42**

1. Radiator Cap
2. Antifreeze Overflow Bottle
3. Radiator Core and Screen

## Cleaning Cooling System

Clean the cooling system daily before each use.

1. Position machine on a level surface, stop the engine and set the parking brake.

**Important** Before starting engine clean grass from pump drive belt compartment. Check more often in dry conditions.

2. Tilt seat up and raise rubber flap above drive belt compartment.
3. Remove debris from drive belt compartment and hydraulic pumps.
4. Remove debris from screen on engine cover.
5. Tilt engine cover forward.
6. Remove debris from radiator core and engine (Fig. 42).

**Important** Do not damage radiator cooling fins.

7. Inspect seals on engine cover and replace if needed.
8. Close engine cover and tilt seat back.

## Changing Engine Coolant

Change engine coolant every 400 hours.

! **Danger** !

**Discharge of hot pressurized coolant or touching hot radiator and surrounding parts can cause severe burns.**

- Do not remove the radiator cap when the engine is hot. Always allow the engine to cool at least 15 minutes or until the radiator cap is cool enough to touch without burning your hand before removing the radiator cap.
- Do not touch radiator and surrounding parts that are hot.

! **Danger** !

**Rotating shaft and fan can cause personal injury.**

- Do not operate the machine without the covers in place.
- Keep fingers, hands and clothing clear of rotating fan and drive shaft.
- Shut off the engine and remove the ignition key before performing maintenance.

1. Position machine on a level surface, stop the engine and set the parking brake.
  2. Tilt seat up and tilt engine hood forward.
  3. With engine cool, drain coolant by loosening the drain cock in the right rear corner (Fig. 43)
  4. The engine block must be drained by removing the drain plug from the engine block (Fig. 44).
- Note:** The drain plug is black in color and is located near the oil filter (Fig. 44).
5. Re-install all drain plugs, radiator hose and tighten drain cock.

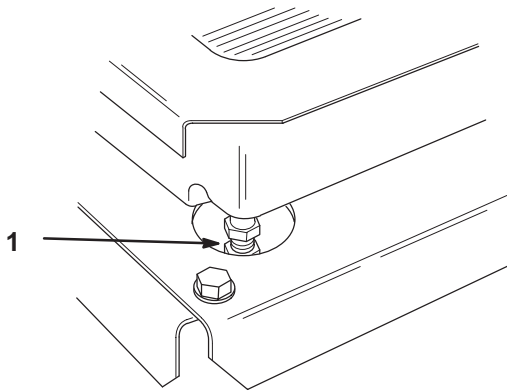

M-4379

**Figure 43**

1. Drain Cock (Right rear of Radiator)

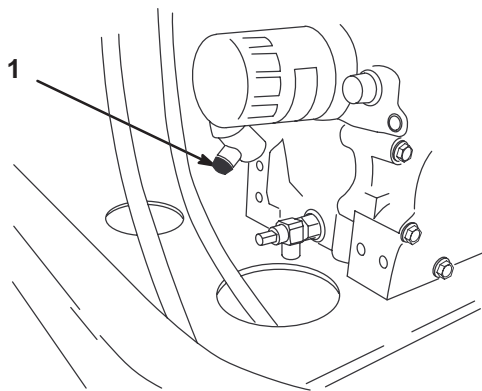

m-5030

**Figure 44**

1. Coolant Drain Plug (Black in color)

6. Drain coolant from overflow bottle.
7. Remove the radiator cap and add 50/50 mixture of permanent antifreeze and water until completely full.
8. Wait 2 minutes and check if coolant stays up to full level. Add 50/50 mixture of permanent antifreeze and water until completely full, if required. Repeat until the coolant stays up to the full level.
9. With the radiator cap off, tilt the engine cover down and put the seat down. Start the engine. Run engine until it is warm.
10. Tilt seat up, tilt engine hood forward and keep engine running. As air is purged from the engine block and the coolant level drops, add additional coolant to the radiator until full.
11. Reinstall radiator cap. Completely seat cap by pushing down and turning until it stops.
12. Shut off engine.
13. Check for any leaks in the cooling system.

14. Close engine cover and tilt seat back.

**Important** Check level of coolant after the first 8 hours of changing coolant.

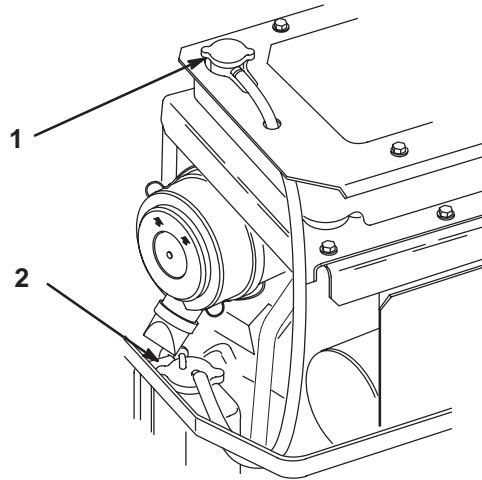

m-5031

**Figure 45**

1. Radiator Cap
2. Antifreeze Overflow Bottle

## Cooling System Inspection

Inspect the radiator and the hoses initially and after first 8 hours.

Inspect the radiator and the hoses every 200 hours.

1. Check hoses and radiator for cracks, dents and fractured seams. Repair or replace damaged hoses or radiator.

## Spark Plug

Check the spark plug(s) after every 100 operating hours. Make sure the air gap between the center and side electrodes is correct before installing the spark plug. Use a spark plug wrench for removing and installing the spark plug(s) and a gapping tool/feeler gauge to check and adjust the air gap. Install a new spark plug(s) if necessary.

Type: NGK BPR2ES (or equivalent) Air Gap: 0.030 in. (0.75 mm)

## Removing the Spark Plug(s)

1. Disengage the power take off (PTO) and turn the ignition key to "OFF" to stop the engine. Move levers to neutral locked position and apply parking brake. Remove the key.
2. Clean around the spark plug(s) to prevent dirt from falling into the engine and potentially causing damage. Pull the wire(s) off the spark plug(s) (Fig. 46).
3. Remove the spark plug(s) and metal washer.

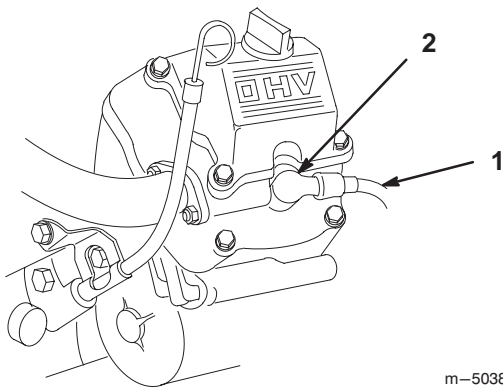

m-5038

**Figure 46**

1. Spark plug wire
2. Spark plug

## Checking the Spark Plug

1. Clean the electrodes by scraping or with a wire brush to remove carbon deposits and wetness (Fig. 47).
2. Inspect spark plug (Fig. 47).

**Important** Always replace the spark plug(s) when it has: a black coating, worn electrodes, an oily film, or cracks.

3. Check the gap between the center and side electrodes (Fig. 47). Bend the side electrode (Fig. 47) if the gap is not correct.

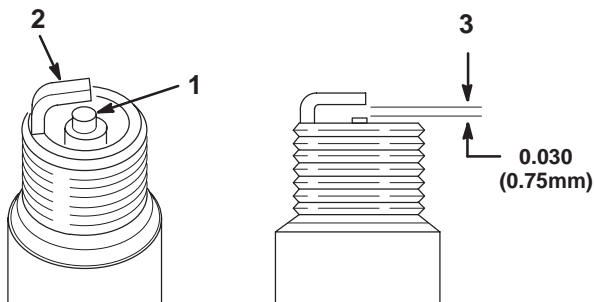

m-3215

**Figure 47**

1. Center electrode insulator
2. Side electrode
3. Air gap (not to scale)

## Installing the Spark Plug(s)

1. Install the spark plug(s). Make sure the air gap is set correctly.
2. Tighten the spark plug(s) to 17 ft-lb (23 N.m).
3. Push the wire(s) onto the spark plug(s) (Fig. 46).

## Fuel Filter

Replace the fuel filter after every 300 operating hours or yearly, whichever occurs first.

## Replacing the Fuel Filter

Never install a dirty filter if it is removed from the fuel line.

1. Disengage the power take off (PTO) and turn the ignition key to "OFF" to stop the engine. Move levers to neutral locked position and apply parking brake. Remove the key.
2. Close fuel shut-off valve on console.
3. Tilt seat forward to access fuel filter.
4. Squeeze the ends of the hose clamps together and slide them away from the filter (Fig. 48).
5. Remove the filter from the fuel lines.
6. Install a new filter and move the hose clamps close to the filter (Fig. 49).
7. Wipe up any spilled fuel.
8. Open fuel shut-off valve on console.

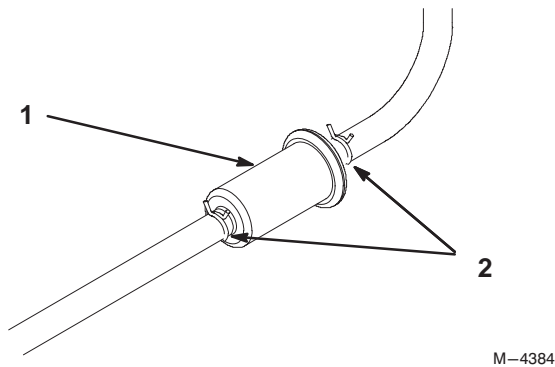

**Figure 48**

1. Filter  
2. Hose clamp

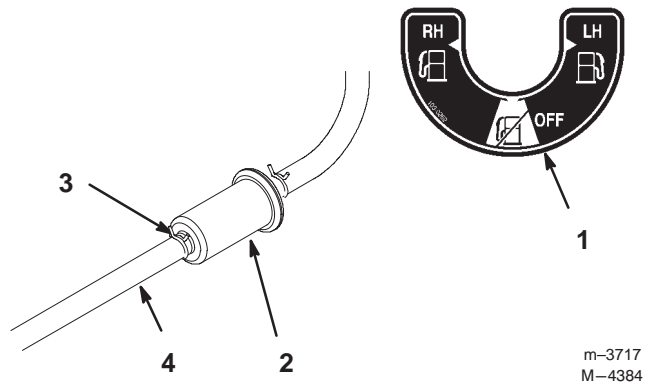

**Figure 49**

1. Fuel shut-off valve  
2. Fuel filter  
3. Hose clamp  
4. Fuel line

m-3717  
M-4384

## Fuel Tank

### Draining The Fuel Tank

⚠
Danger
⚠

**In certain conditions, gasoline is extremely flammable and highly explosive. A fire or explosion from gasoline can burn you and others and can damage property.**

- **Drain gasoline from the fuel tank when the engine is cold. Do this outdoors in an open area. Wipe up any gasoline that spills.**
- **Never smoke when draining gasoline, and stay away from an open flame or where a spark may ignite the gasoline fumes.**

1. Park the machine on a level surface, to assure fuel tank drains completely. Then disengage the power take off (PTO), set the parking brake, and turn the ignition key to "OFF" to stop the engine. Remove the key.
2. Close fuel shut-off valve (Fig. 49).
3. Loosen the hose clamp at the fuel filter and slide it up the fuel line away from the fuel filter (Fig. 49).
4. Pull the fuel line off fuel filter (Fig. 49). Open fuel shut-off valve and allow gasoline to drain into a gas can or drain pan.

**Note:** Now is the best time to install a new fuel filter because the fuel tank is empty.

5. Install the fuel line onto the fuel filter. Slide the hose clamp close to the fuel filter to secure the fuel line (Fig. 49).

## Servicing the Spark Arrester

Inspect the spark arrester every 50 hours for damage, such as holes in the screen, and for build-up on the screen. If it is damaged, replace it with a new spark arrester. If it is dirty, remove it and clean the screen with a wire brush and/or soak it in solvent.

## Greasing and Lubrication

Lubricate the machine when shown on the CHECK SERVICE REFERENCE AID decal (Fig. 50). Grease more frequently when operating conditions are extremely dusty or sandy.

Grease Type: General-purpose grease.

### How to Grease

1. Disengage the power take off (PTO) and turn the ignition key to "OFF" to stop the engine. Move levers to neutral locked position and apply parking brake. Remove the key.
2. Clean the grease fittings with a rag. Make sure to scrape any paint off the front of the fitting(s).
3. Connect a grease gun to the fitting. Pump grease into the fittings until grease begins to ooze out of the bearings.
4. Wipe up any excess grease.

### Grease Front Castor Pivots

Lubricate the front castor pivots once a year.

1. Remove hex plug and cap. Thread a grease zerk into hole.

2. Pump grease into zerk until it oozes out around top bearing.
3. Remove grease zero in hole. Reinstall hex plug and cap.

## Where to Add Grease

Lubricate the grease fittings as shown on the CHECK SERVICE REFERENCE AID decal (Fig. 50).

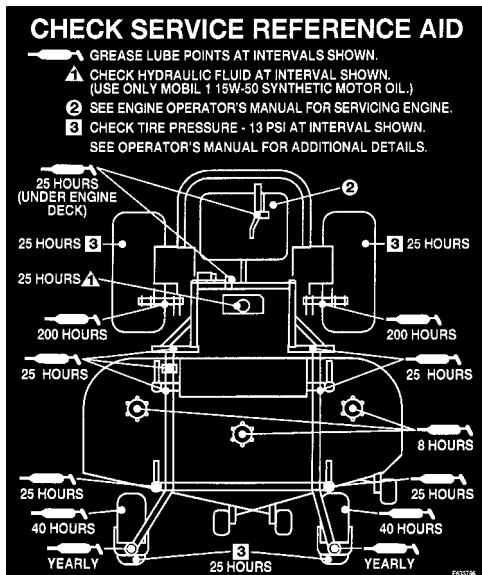

Figure 50

## Where to Add Light Oil or Spray Lubrication

Lubricate the machine in the following areas with spray type lubricant or light oil. Lubricate every 160 hours.

- Seat switch actuator.
- Brake handle pivot.
- Brake rod bushings.
- Motion control bronze bushings.

## Greasing the Bearings

The cutting unit must be lubricated daily. Refer to the Service Interval Chart on page NO TAG. Grease with No. 2 general purpose lithium base or molybdenum base grease.

**Important** Make sure cutting unit spindles are full of grease daily.

1. Stop the engine, set the parking brake, remove the key and disconnect the spark plug wire(s) from the spark plug(s).

2. Grease the fittings on the three spindle bearings until grease comes out lower seals (Fig. 51).
3. Grease the fittings on the push arms (Fig. 51).

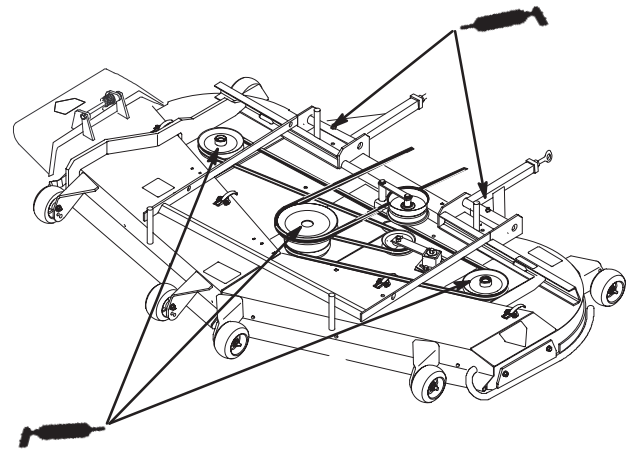
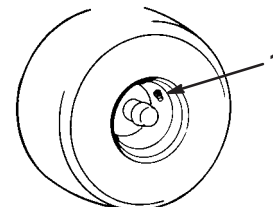

Figure 51

## Tire Pressure

Maintain the air pressure in the front and rear tires as specified. Uneven tire pressure can cause uneven cut. Check the pressure at the valve stem after every 50 operating hours or monthly, whichever occurs first (Fig. 52). Check the tires when they are cold to get the most accurate pressure reading.

Pressure: 13 psi (90 kPa) drive wheels and castor wheels.



m-1872

Figure 52

1. Valve stem

## Wheel Hub Slotted Nut

Check after every 500 operating hours.

The slotted nut needs to be torqued to 125 ft-lbs (169.5 N•m).

1. Stop the engine, set the parking brake, remove the key and disconnect the spark plug wire(s) from the spark plug(s).

2. Remove cotter pin.
3. Torque slotted nut to 125 ft-lbs (169.5 N•m) (Fig. 53).
4. Check the distance from bottom of slot in nut to inside edge of hole. Two threads or less should be showing (Fig. 53).
5. If more than two threads are showing remove nut and install washer between hub and nut (Fig. 53).
6. Torque the slotted nut to 125 ft-lbs (169.5 N•m) (Fig. 53).
7. Tighten nut until the next set of slots line up with the hole in the shaft (Fig. 53).
8. Replace cotter pin.

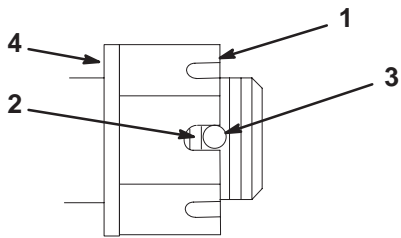

**Figure 53**

m-4638

- |                                |                         |
|--------------------------------|-------------------------|
| 1. Slotted Nut                 | 3. Hole in threaded rod |
| 2. Two threads or less showing | 4. Washer (if needed)   |

## Castor Pivot Bearing Adjustment

Check after every 500 operating hours or at storage, whichever comes first.

1. Stop the engine, set the parking brake, remove the key and disconnect the spark plug wire(s) from the spark plug(s).
2. Remove dust cap from castor and tighten lock nut (Fig. 54).
3. Tighten until spring washers are flat and then back off a 1/4 turn to properly set the pre-load on the bearings (Fig. 54).

**Important** Make sure spring washers are installed correctly as shown in figure 54.

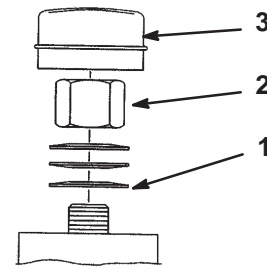

**Figure 54**

M-4640

- |                   |             |
|-------------------|-------------|
| 1. Spring Washers | 3. Dust Cap |
| 2. Lock Nut       |             |

## Hydraulic System

### Checking the Hydraulic Fluid

Check the hydraulic fluid level before engine is first started.

Check the hydraulic fluid level after first 8 operating hours.

Check the hydraulic fluid level after every 25 operating hours.

Fluid Type: Mobil 1 15W-50 synthetic motor oil.

**Important** Use only oil specified. Other fluids could cause system damage.

System Capacity: 2.1 qt. (2.0 l)

1. Position machine on a level surface, stop the engine and set the parking brake.
2. Clean area around filler neck of hydraulic tank (Fig. 11).
3. Remove cap from filler neck. Look inside to check if there is fluid in the reservoir. (Fig. 11).
4. If there is no fluid, add fluid to reservoir approximately a 1/4" (6mm) below the top of baffle.
5. Run the machine 15 minutes to allow any air to purge out of the system.
6. Recheck level while fluid is warm. Add fluid to raise level to top of the baffle, if required.

**Note:** Fluid level should be to the top of the baffle when fluid is warm (Fig. 11).



7. Install cap on filler neck.

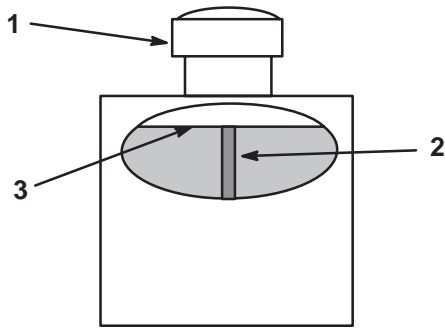

**Figure 55**

1. Cap
2. Baffle
3. Fluid level-Full

M-4280

1. Disengage the power take off (PTO) and turn the ignition key to “OFF” to stop the engine. Move levers to neutral locked position and apply parking brake. Remove the key.

**Important** Do not substitute automotive oil filter or severe hydraulic system damage may result.

2. Tilt seat forward to access filter.
3. Remove hydraulic reservoir cap and temporarily cover opening with a plastic bag and rubber band to prevent all hydro fluid from draining out.
4. Place drain pan under filter, remove the old filter and wipe the filter adapter gasket surface clean (Fig. 56).

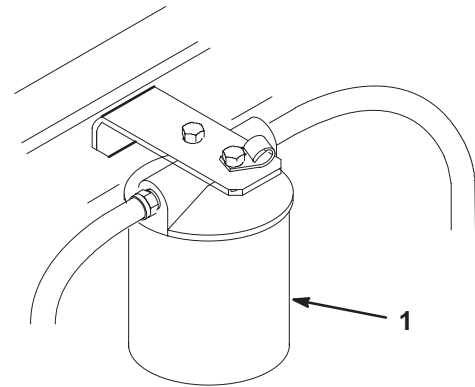

**Figure 56**

M-4384

1. Hydraulic filter



## Warning



Hydraulic fluid escaping under pressure can penetrate skin and cause injury.

- If hydraulic fluid is injected into the skin it must be surgically removed within a few hours by a doctor familiar with this type of injury. Gangrene may result if this is not done.
- Keep body and hands away from pin hole leaks or nozzles that eject high pressure hydraulic fluid.
- Use cardboard or paper to find hydraulic leaks.
- Safely relieve all pressure in the hydraulic system before performing any work on the hydraulic system.
- Make sure all hydraulic fluid hoses and lines are in good condition and all hydraulic connections and fittings are tight before applying pressure to hydraulic system.

## Replacing the Hydraulic Filter

Change the hydraulic filter:

- After the first 8 operating hours.
- After every 200 operating hours.
- Use summer filter above 32°F (0°C)  
Use winter filter below 32°F (0°C)

5. Apply a thin coat hydro fluid to the rubber gasket on the replacement filter (Fig. 57).
6. Install replacement hydraulic filter onto the filter adapter. Do not tighten.
7. Remove plastic bag from tank opening and allow filter to fill with hydro fluid.
8. When fluid overflows filter turn the oil filter clockwise until the rubber gasket contacts the filter adapter, then tighten the filter an additional 1/2 turn (Fig. 57).
9. Clean up any spilled fluid.
10. If there is no fluid, add fluid to reservoir approximately a 1/4" (6mm) below the top of baffle.
11. Start engine and let run for about two minutes to purge air from the system. Stop the engine and check for leaks. If one or both wheels will not drive, refer Bleeding Hydraulic System, page 42.

12. Recheck level while fluid is warm. Add fluid to raise level to top of the baffle, if required. **Do not over fill.**

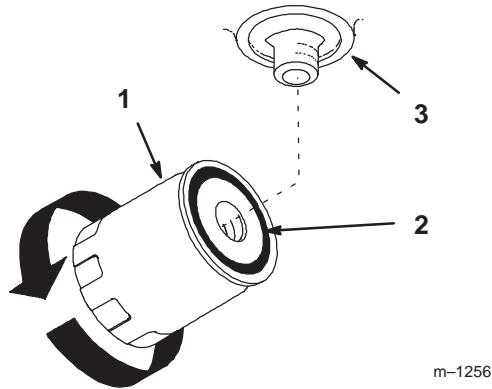

Figure 57

1. Hydraulic filter
2. Gasket
3. Adapter

## Bleeding Hydraulic System

The traction system is self bleeding, however, it may be necessary to bleed the system if fluid is changed or after work is performed on the system.

1. Raise rear of the machine so wheels are off the ground and support with jack stands.
2. Start the engine and run at idle speed. Engage traction on one side and spin the wheel by hand.
3. When the wheel begins to spin on its own, keep it engaged until wheel drives smoothly. (minimum 2 minutes)
4. Check hydraulic fluid level as it drops and add as required to maintain proper level.
5. Repeat procedure on opposite wheel.

## Check Hydraulic Lines

After every 100 operating hours, check hydraulic lines and hoses for leaks, loose fittings, kinked lines, loose mounting supports, wear, weather and chemical deterioration. Make necessary repairs before operating.

**Note:** Keep areas around hydraulic system clean from grass and debris build up.



## Warning



Hydraulic fluid escaping under pressure can penetrate skin and cause injury.

- If hydraulic fluid is injected into the skin it must be surgically removed within a few hours by a doctor familiar with this type of injury. Gangrene may result if this is not done.
- Keep body and hands away from pin hole leaks or nozzles that eject high pressure hydraulic fluid.
- Use cardboard or paper to find hydraulic leaks.
- Safely relieve all pressure in the hydraulic system before performing any work on the hydraulic system.
- Make sure all hydraulic fluid hoses and lines are in good condition and all hydraulic connections and fittings are tight before applying pressure to hydraulic system.

## Adjusting Motion Controls

### Adjusting Handle Neutral

If motion control levers do not align, or move easily into the console notch, adjustment is required. Adjust each lever, spring and rod separately.

**Note:** Motion control levers must be installed correctly. See Install Motion Control Levers on page 15.

1. Stop engine, remove ignition key and tilt seat forward.
2. Begin with either the left or right motion control lever. Move lever to the neutral (but not locked) position and pull lever back until the clevis pin (on arm below pivot shaft) contacts the end of the slot (just beginning to put pressure on spring) (Fig. 58).
3. Check where lever is relative to notch in console (should be centered allowing lever to pivot outward to the neutral lock position) (Fig. 58).
4. If adjustment is needed, loosen the nut against the yoke.
5. Apply slight rearward pressure on the motion control lever, turn the head of the adjustment bolt in the appropriate direction until lever is centered in neutral lock position (keeping rearward pressure on the lever

will keep the pin at the end of the slot and allow the adjustment bolt to move the lever to the appropriate position).

6. Tighten nut and jam nut.
7. Repeat on opposite side of unit.

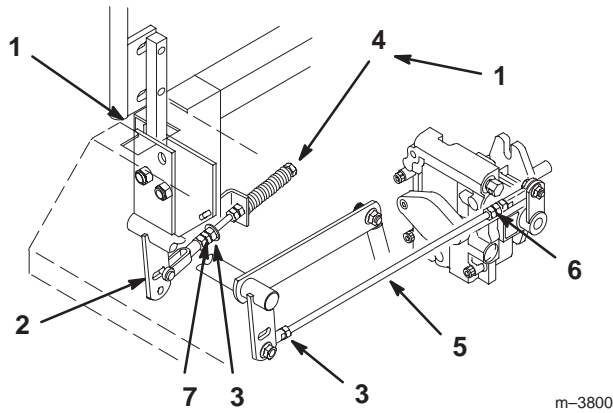

**Figure 58**

- |                          |                |
|--------------------------|----------------|
| 1. Neutral lock position | 5. Pump rod    |
| 2. Clevis pin in slot    | 6. Double nuts |
| 3. Nut                   | 7. Jam Nut     |
| 4. Bolt                  |                |

## Adjusting Hydraulic Pump Neutral

**Note:** Adjust handle neutral first. That has to be correct before the following adjustment can be made.

**Danger**

**Mechanical or hydraulic jacks may fail to support machine and cause a serious injury.**

- Use jack stand when supporting machine.
- Do not use hydraulic jacks.

1. This adjustment must be made with drive wheels turning. First raise the frame and block up so drive wheels can rotate freely.

**Warning**

**Engine must be running so motion control adjustment can be performed. Contact with moving parts or hot surfaces may cause personal injury.**

**Keep hands, feet, face, clothing and other body parts away from rotating parts, muffler and other hot surfaces.**

2. Slide seat forward, disconnect prop rod and tilt seat fully forward.
3. Disconnect electrical connector from the seat safety switch. **Temporarily** install a jumper wire across terminals in the wiring harness connector.
4. Loosen locknut at ball joint on pump control rod (Fig. 58).

**Note:** The front nut of each rod has left-hand threads.

5. Start engine, open throttle 1/2 way and release parking brake. Refer to Starting and Stopping the Engine, page 20.
6. Adjust pump rod length by rotating double nuts on rod, in the appropriate direction, until wheel is still or slightly creeps in reverse (Fig. 58).
7. Move motion control lever forward and reverse, then back to neutral. Wheel must stop turning or slightly creep in reverse.

**Note:** Motion control lever must be in neutral while making any adjustments.

8. Open throttle to fast. Make sure wheel remains stopped or slightly creeps in reverse, re-adjust if necessary.
9. Repeat on opposite side of unit. Tighten locknuts against ball joints.

**Warning**

**Electrical system will not perform proper safety shut off with jumper wire installed.**

- Remove jumper wire from wire harness connector and plug connector into seat switch when adjustment is completed.
- Never operate this unit with jumper installed and seat switch bypassed.

10. Shut off unit. Remove jumper wire from wire harness connector and plug connector into seat switch.
11. Reinstall prop rod and lower seat.

## Throttle Lever Adjustment

The tension can be adjusted by adjusting the tightness of lever pivot bolt. Do this when needed.

1. Stop engine, remove ignition key.
2. Remove console from machine to gain access to throttle lever.
3. Tighten nut and bolt. Test lever and adjust to desired tension (Fig. 59).

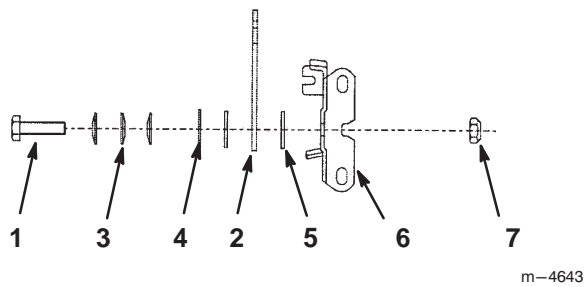

**Figure 59**

- |                       |            |
|-----------------------|------------|
| 1. Pivot Bolt         | 5. Washer  |
| 2. Throttle Lever     | 6. Bracket |
| 3. Belleville Washers | 7. Nut     |
| 4. Tab Washer         |            |

## Replacing the Pump Drive Belt

Check pump drive belt for wear after every 50 hours of operation.

1. Pull spring loaded idler down and remove traction belt from the engine and hydro pump pulleys (Fig. 60). Remove belt between pulleys.
2. Install new belt around engine and hydro pump pulleys (Fig. 60).
3. Pull spring loaded idler down and align below traction belt. Release pressure on spring loaded idler (Fig. 60).

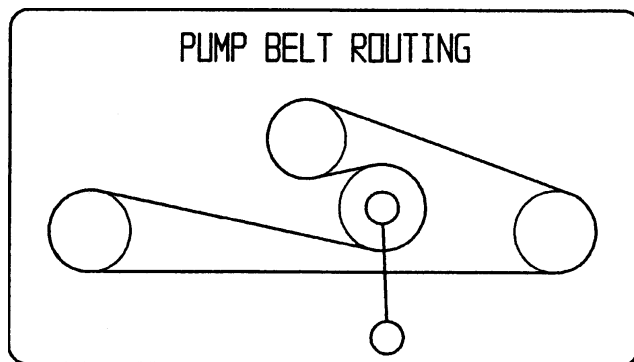

**Figure 60**

## Adjustment Parking Brake

Check parking brake for proper adjustment.

1. Disengage brake lever (lever down).
2. Measure the length of the spring. Measurement should be 2.75" (70 mm) between washers (Fig. 61).

3. If adjustment is necessary, loosen the jam nut below the spring and tighten the nut directly below the yoke (Fig. 61). Turn the nut until the correct measurement is obtained. Tighten the two nuts together and repeat on opposite side of unit.
4. Turn nuts clockwise to shorten spring length and turn counter-clockwise to lengthen the spring.
5. Engage parking brake, lever up.
6. Measure the distance between the trunnion roller and the collar on brake rod. Measurement should be 3/16"-1/4" (5-7 mm) (Fig. 61).
7. If adjustment is necessary, loosen the jam nut directly below the yoke. Turn the bottom rod until the correct measurement is obtained (Fig. 61). Tighten jam nut at yoke

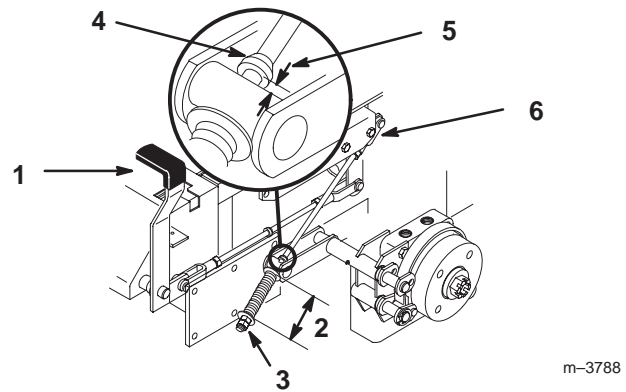

**Figure 61**

- |                         |                        |
|-------------------------|------------------------|
| 1. Brake lever          | 4. Collar on brake rod |
| 2. Spring 2.75" (70 mm) | 5. 3/16"-1/4" (5-7 mm) |
| 3. Adjusting nuts       | 6. Jam nut and yoke    |

## Fuse

### Service Interval/Specification

The electrical system is protected by fuses. It requires no maintenance, however, if a fuse blows check component/circuit for malfunction or short.

Fuse: Main -20 amp, blade-type  
 Alternator -30 amp, blade-type  
 Fan-30 amp, blade-type

1. To gain access to the main fuse just raise seat. To gain access to the fan and alternator fuses raise seat and tilt engine cover forward .
2. To replace fuse, pull out on the fuse to remove it (Fig. NO TAG and 62).

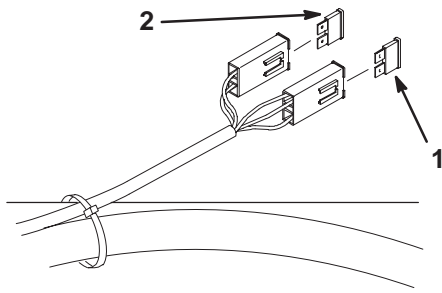

**Figure 62**

1. Fan-30 amp
2. Main-20 amp

m-3653

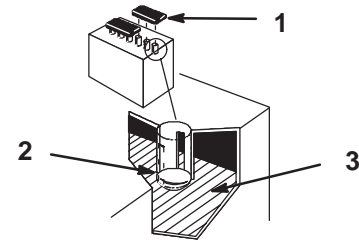

**Figure 63**

1. Filler caps
2. Lower part of tube
3. Plates

1262

## Battery

! **Warning** !

**Battery posts, terminals, and related accessories contain lead and lead compounds, chemicals known to the State of California to cause cancer and reproductive harm. Wash hands after handling.**

Check the electrolyte level in the battery every 25 hours. Always keep the battery clean and fully charged. Use a paper towel to clean the battery case. If the battery terminals are corroded, clean them with a solution of four parts water and one part baking soda. Apply a light coating of grease to the battery terminals to prevent corrosion.

Voltage: 12 v

### Checking Electrolyte Level

1. Open covers to see into the cells. The electrolyte must be up to the lower part of the tube (Fig. 63). Do not allow the electrolyte to get below the plates. (Fig. 63).
2. If the electrolyte is low, add the required amount of distilled water; refer to Adding Water to the Battery, below.

### Adding Water to the Battery

The best time to add distilled water to the battery is just before you operate the machine. This lets the water mix thoroughly with the electrolyte solution.

1. Clean the top of the battery with a paper towel.
2. Lift off the filler caps (Fig. 63).
3. Slowly pour distilled water into each battery cell until the level is up to the lower part of the tube (Fig. 63).

**Important** Do not overfill the battery because electrolyte (sulfuric acid) can cause severe corrosion and damage to the chassis.

4. Press the filler caps onto the battery.
5. Position drain tube away from belts and other parts to prevent corrosion.

### Charging the Battery

**Important** Always keep the battery fully charged (1.260 specific gravity). This is especially important to prevent battery damage when the temperature is below 32°F (0°C).

1. Check the electrolyte level; refer to Checking Electrolyte Level, page 45.
2. Remove the filler caps from the battery and connect a 3 to 4 amp battery charger to the battery posts. Charge the battery at a rate of 4 amperes or less for 4 hours (12 volts). Do not overcharge the battery. Install the filler caps after the battery is fully charged.



## Warning



Charging battery produces gasses that can explode and cause serious injury.

- Keep cigarettes, sparks and flames away from battery.
- Make sure the ignition switch is off.
- Ventilate when charging or using battery in an enclosed space.

## Mower Leveling

1. Position mower on a flat surface. Stop the engine, set the parking brake, remove the key and disconnect the spark plug wire(s) from the spark plug(s).
2. Check tire pressure of all four (4) tires. If needed, adjust to 13 psi (90 kPa)
3. Set anti-scalp rollers to top holes or remove them completely for this adjustment.
4. Raise the deck to the transport position and take all force off of the two large deck lift springs by loosening nut in front of each spring (Fig. 64).
5. Place two 1-1/2" (38 mm) thick blocks under rear left and right lower edge of mower. Place one 2-1/4" (57 mm) block under front center lower edge of mower. Lower mower to the 2" (51 mm) height-of-cut position (Fig. 64).

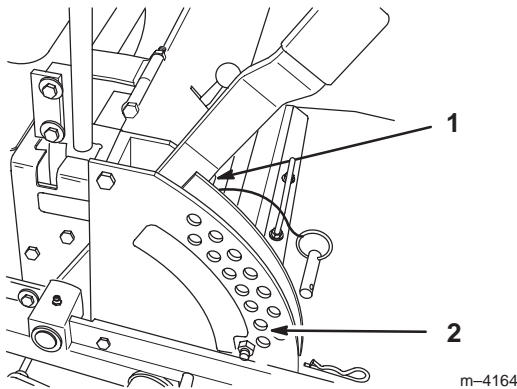

Figure 64

1. Transport position
2. 2" (51 mm) height-of-cut

6. Loosen four (4) top chain bolts in slots. Check the length of the rod/swivel assemblies. Distance from outside of rear swivel to outside of front swivel should be 19-17/32" (496 mm) (Fig. 65). Make sure that all four swivels move freely in holes.
7. If measurement is not 19-17/32" (496 mm) on each side, adjust by turning nuts on either side of front swivels.

8. Lift up on four (4) top chain attachment bolts, in the slots, to take slack out of chains and tighten flange lock nuts. (Deck is still supported by two rear and one front blocks under mower.)
9. If bolts contact the end of slots, shorten or lengthen rod/swivel assemblies as required, for extra clearance, adjust each side same amount.

**Note:** When properly adjusted, the front blade tip will be slightly lower than the rear blade tip. See Checking for Bent Blades on page 30 to measure.

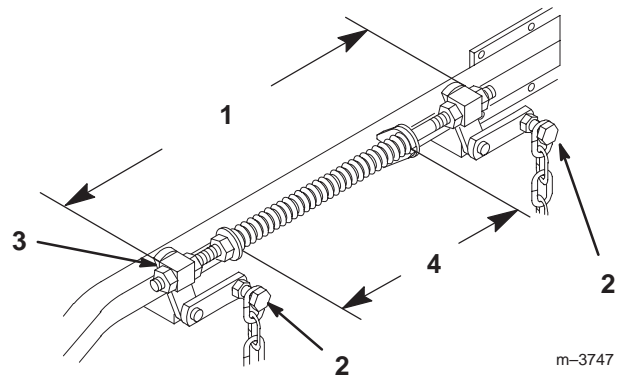

Figure 65

1. 19-17/32" (496 mm) outside swivels
2. Top chain bolt
3. Front swivel
4. 10-1/4" (260 mm) spring compressed

10. Recheck that blocks just fit just under the mower and that tension on all four chains is approximately equal. Tighten chain attachment bolts securely.
11. Measure height of cut. This can be checked with the same procedure as Checking for Bent Blades on page 30.
12. Install anti-scalp rollers for proper height-of-cut and tighten securely.

## Compression Spring Adjustment



1. Raise deck lift lever to the transport position, (Fig. 64).
2. Springs are compressed so the distance between the two large washers should be 10-1/4" (260 mm) (Fig. 65).
3. Adjust by turning nut in front of each spring (Fig. 65). Clockwise will shorten spring; counter-clockwise will lengthen spring.

## Clean Under Deck

Remove grass build up under deck daily.

1. Position mower on a flat surface. Stop the engine, set the parking brake, remove the key and disconnect the spark plug wire(s) from the spark plug(s).

2. Raise deck to the transport position.
3. Raise front of machine by using the Z Stand. Refer to Z Stand operation on page 26.

	Danger	
<p><b>Unit could fall onto someone and cause serious injury or death.</b></p> <ul style="list-style-type: none"> <li>• Use extreme caution when operating unit on Z-Stand.</li> <li>• Use only for cleaning deck and removing blades.</li> <li>• Do not keep unit on Z-Stand for extended periods of time.</li> <li>• Always shut engine off and set parking brake before performing any maintenance to deck.</li> </ul>		

## Belt Inspection

Inspect all belts every 100 hours.

1. Check belts for cracks, frayed edges, burn marks or any other damage. Replace damaged belts.

## Replacing the Deck Belt

Squealing when the belt is rotating, blades slipping when cutting grass, frayed belt edges, burn marks and cracks are signs of a worn deck belt. Replace the deck belt if any of these conditions are evident.

1. Stop the engine, set the parking brake, remove the key and disconnect the spark plug wire(s) from the spark plug(s).
2. Remove the PTO drive belt. Refer to Replacing the PTO Drive Belt, on page 47.
3. Loosen two nuts securing idler plate and move the idler arm to relieve belt tension on the idler pulley, then remove the worn deck belt (Fig. NO TAG).
4. Install the new deck belt around the spindle pulleys, belt guide, the idler pulley, and in the lower groove of the center spindle pulley (Fig. NO TAG).
5. Using a socket and torque wrench, rotate the idler adjusting nut until torque is 25–30 ft.-lb. (34–41 N•m). Tighten two nuts.

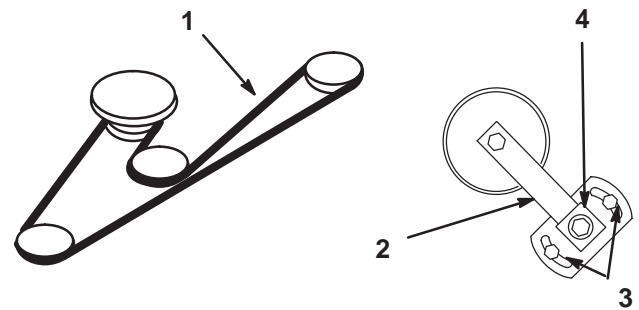

M-4312

**Figure 66**

Top View

- |              |                        |
|--------------|------------------------|
| 1. Deck Belt | 3. Idler nuts          |
| 2. Idler Arm | 4. Idler adjusting nut |

6. Install the PTO drive belt. Refer to Replacing the PTO Drive Belt, page 47.

## Replacing the PTO Drive Belt

Squealing when the belt is rotating, blades slipping when cutting grass, frayed belt edges, burn marks and cracks are signs of a worn drive belt. Replace the PTO drive belt if any of these conditions are evident.

1. Stop the engine, set the parking brake, remove the key and disconnect the spark plug wire(s) from the spark plug(s).
  2. Remove the clutch retaining strap from machine frame and unplug clutch terminal from wire harness (Fig. 67).
  3. Remove PTO drive belt from clutch, around rear idler pulleys and off of mower top center pulley (Fig. 68).
  4. Remove bolt, nut, washer and spacer from idler pulley bracket assembly. Remove belt from bracket assembly (Fig. 68).
  5. Install new PTO drive belt over clutch, around rear idler pulleys and onto mower top center pulley.
- Note:** Check that belt has only 1/4 twist between each pulley and idler.
6. Install belt into idler pulley bracket assembly. Install bolt, nut, washer and spacer into assembly (Fig. 68).

**Note:** Idler belt has to be installed between spacer and PTO belt idler pulley.

7. Install clutch retaining strap and plug clutch terminal into main wire harness (Fig. 67).

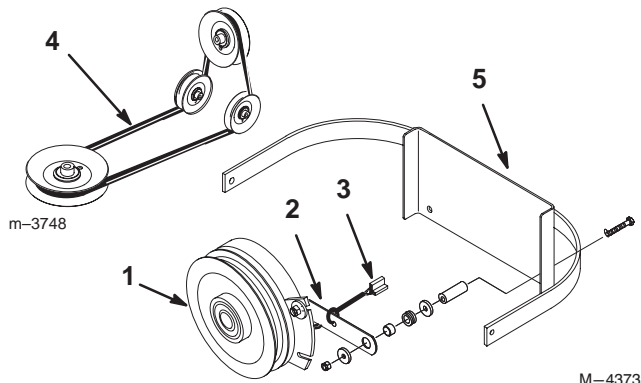

**Figure 67**

- |                           |                  |
|---------------------------|------------------|
| 1. Clutch                 | 4. PTO belt      |
| 2. Clutch retaining strap | 5. Machine Frame |
| 3. clutch Terminal        |                  |

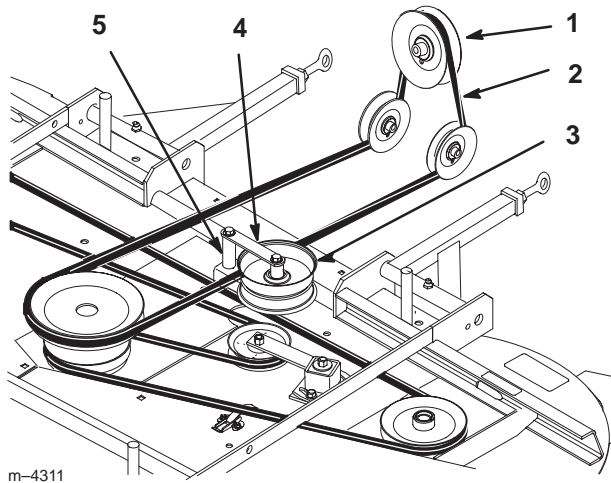

**Figure 68**

- |                            |  |
|----------------------------|--|
| 1. Clutch Pulley           | 4. Idler Bracket Assembly                |
| 2. PTO Drive Belt          | 5. Spacer, Bolt, Nut and washer (Remove) |
| 3. Drive Belt Idler Pulley |  |

8. Check belt tension. The center bolt of spring loaded idler must be between the two alignment holes in left support plate (Fig 69).

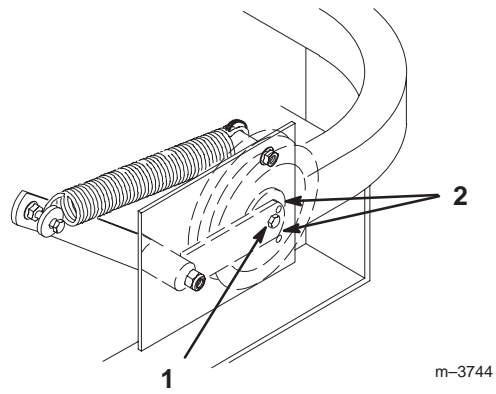

**Figure 69**

- |                                     |                   |
|-------------------------------------|-------------------|
| 1. Center bolt, spring loaded idler | 2. Alignment hole |
|-------------------------------------|-------------------|

9. If adjustment is required, loosen the fixed idler on right support plate and move up or down in adjustment slot (Fig. 70). To relieve belt tension lift up on spring loaded idler.

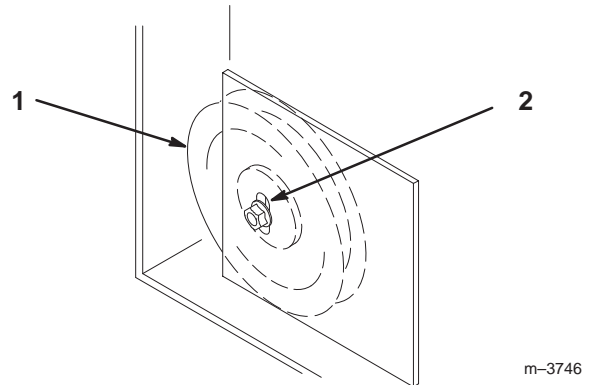

**Figure 70**

- |                |                    |
|----------------|--------------------|
| 1. Fixed Idler | 2. Adjustment slot |
|----------------|--------------------|

10. Check belt tension again. The center bolt of spring loaded idler must be between the two alignment holes in left support plate (Fig. 69). Adjust, if necessary, and tighten all hardware securely.

11. If the fixed idler contacts the end of the adjustment slot and more belt tension is required, a small change to lengthen the push arms can be made (Fig. 71).

12. To adjust push arms, loosen jam nut and rotate ball joint counterclockwise, one turn at a time. Adjust each side the same amount (Fig. 71).

**Note:** Increase belt tension by lengthening the push arms and decrease belt tension by shortening push arms.



**Important** If the push arm lengths are changed, then the mower deck must be leveled. See Mower Leveling on page 46.

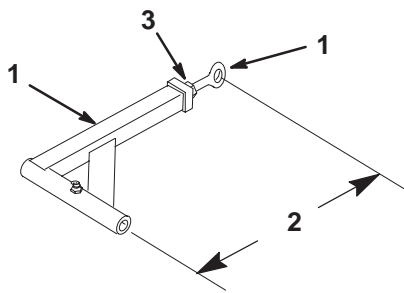

Figure 71

- |                             |               |
|-----------------------------|---------------|
| 1. Push arm                 | 3. Jam nut    |
| 2. 15"-5/16 (389mm) nominal | 4. Ball joint |

m-3740

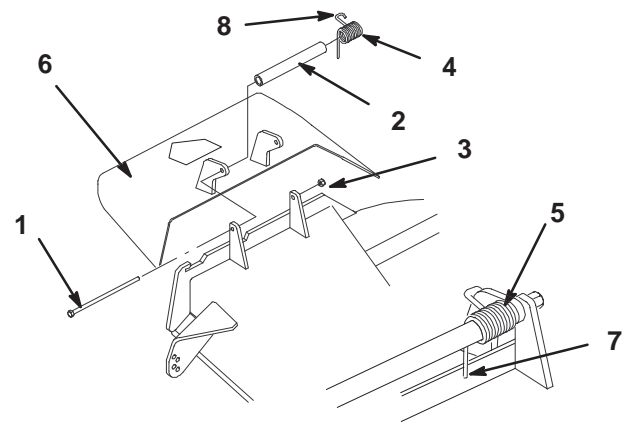

Figure 72

- |                     |  |
|---------------------|--|
| 1. Bolt             | 6. Grass Deflector                               |
| 2. Spacer           | 7. Place behind deck edge before installing bolt |
| 3. Locknut          | 8. Hook end of spring                            |
| 4. Spring           |  |
| 5. Spring installed |  |

m-5037

## Replacing the Grass Deflector



### Warning



An uncovered discharge opening could allow the lawn mower to throw objects in the operator's or bystander's direction and result in serious injury. Also, contact with the blade could occur.

Never operate the lawn mower unless you install a cover plate, a mulch plate, or a grass chute and catcher.

1. Remove the locknut, bolt, spring and spacer holding the deflector to the pivot brackets (Fig.72). Remove damaged or worn grass deflector.
2. Place spacer and spring onto grass deflector. Place the straight end of spring behind deck edge.

**Note:** Make sure the straight end of spring is installed behind deck edge before installing the bolt as shown in figure 72.

3. Install bolt and nut. Place hook end of spring around grass deflector (Fig.72).

**Important** The grass deflector must be able to lower down into position. Lift the deflector up to test that it lowers into the full down position.

## Waste Disposal

Engine oil, hydraulic oil and engine coolant are pollutants to the environment. Dispose of these according to your state and local regulations.

## Mercury Tilt Switch

The tilt switch on this unit is located under the seat. Tilt seat up to gain access.

The tilt switch on this unit contains mercury, a hazardous material. Mercury that is outside a sealed container vaporizes at room temperature. The vapors are harmful. Mercury can be absorbed through the skin. Do not attempt to open or repair this switch.

A very small amount of mercury is contained in a hermetically sealed body. The steel switch is then potted in a hard epoxy in a plastic case. It is unlikely that the mercury will ever escape from the enclosure. These high performance and reliable inexpensive switches are recyclable.

Mercury is an important and beneficial compound but requires special care in handling and disposal. When used and managed properly, mercury is not a threat to people or the environment. This information is presented to users so that they are aware that these switches contain mercury and will apply sound disposal practices when these devices reach their normal end of life or are damaged.

## Mercury Tilt Switch Disposal

Several states have passed laws concerning the disposal of devices containing mercury. In all the remaining states it is advisable to follow similar procedures. The laws state that these sealed devices contain mercury and should not be placed in the garbage until the mercury is removed and reused, recycled or otherwise managed to insure that it does not become part of solid waste or waters. Management and disposal practices must be within relevant federal, state or local laws.

Return the switch to your Toro dealer if it is faulty and is being replaced or if the unit containing the switch is no longer operating and is being scrapped. If the switch is damaged or broken open use extreme caution in handling. Call your local waste management authority or Toro Customer Service for instructions.



### Caution



**The mercury contained in the tilt switch is poisonous and exposure to mercury can cause severe illness.**

- **Never attempt to open or repair the tilt switch.**
- **Avoid contact with the mercury.**

# Wiring Diagram

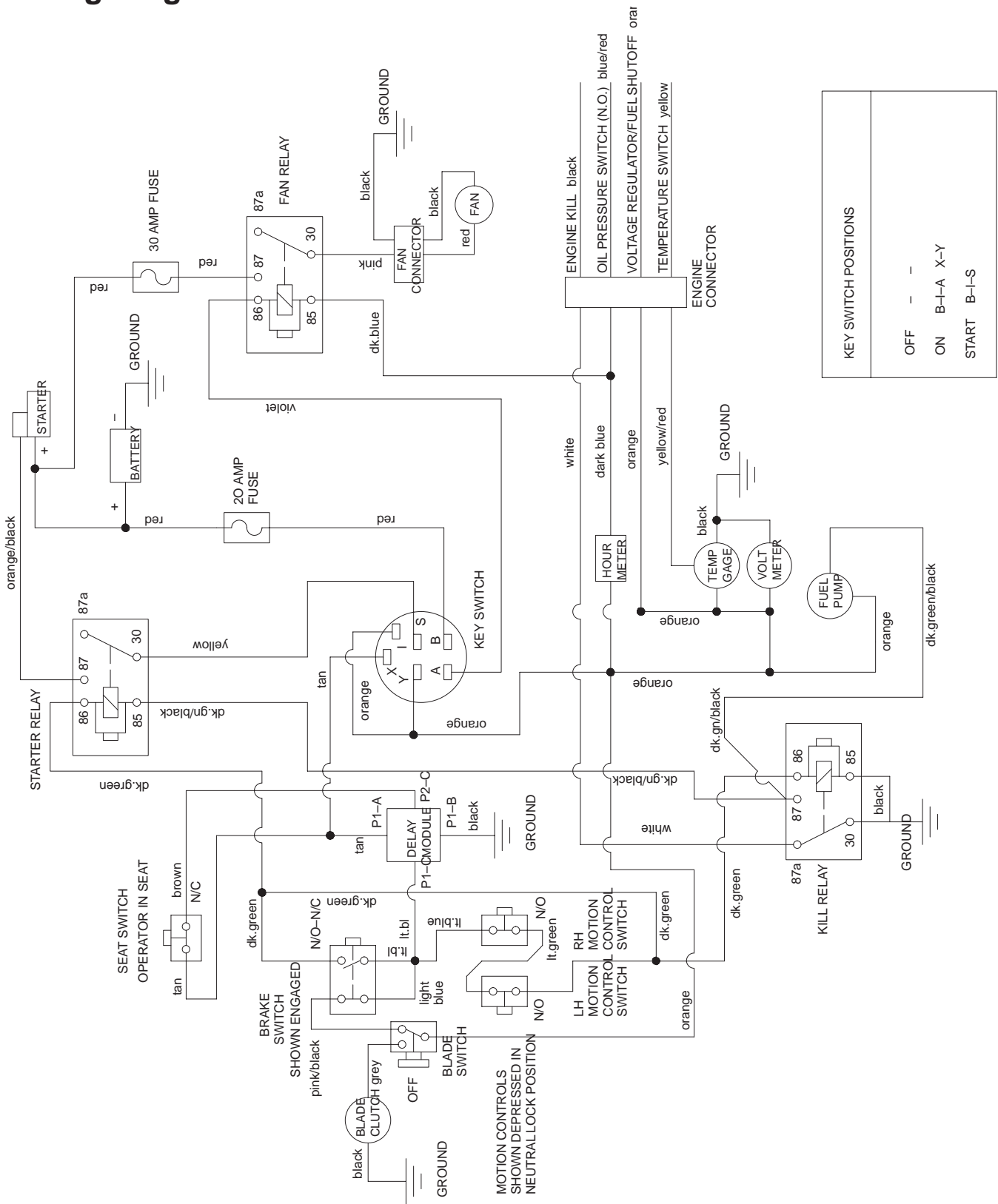

KEY SWITCH POSITIONS	
OFF	- -
ON	B-I-A X-Y
START	B-I-S

## Cleaning and Storage

1. Disengage the power take off (PTO), set the parking brake and turn the ignition key to "OFF" to stop the engine. Remove spark plug wire. Remove the key.
2. Remove grass clippings, dirt, and grime from the external parts of the entire machine, especially the engine and hydraulic system. Clean dirt and chaff from the outside of the engine's cylinder head fins and blower housing.

**Important** You can wash the machine with mild detergent and water. Do not pressure wash the machine. Avoid excessive use of water, especially near the control panel, engine, hydraulic pumps and motors.

3. Service the air cleaner; refer to Air Cleaner, page 32.
4. Grease and oil the machine; refer to Greasing and Lubrication, page 38.
5. Change the crankcase oil; refer to Engine Oil, page 32.
6. Change the hydraulic filter; refer to Hydraulic System, page 18.
7. Check the tire pressure; refer to Tire Pressure, page 39.
8. Charge the battery; refer to Battery page 45.
9. Scrape any heavy buildup of grass and dirt from the underside of the mower, then wash the mower with a garden hose.
10. Check the condition of the blades. Refer to Cutting Blades on page 30.
11. Prepare the machine for storage when non-use occurs over 30 days. Prepare machine for storage as follows.
  - A. Add a petroleum based stabilizer/conditioner to fuel in the tank. Follow mixing instructions from stabilizer manufacture. (1 oz. per gallon). **Do not use an alcohol based stabilizer (ethanol or methanol).**

**Note:** A fuel stabilizer/conditioner is most effective when mixed with fresh gasoline and used at all times.

- B. Run engine to distribute conditioned fuel through the fuel system (5 minutes).
- C. Stop engine, allow to cool and drain the fuel tank; refer to Fuel Tank, page 38.
- D. Restart engine and run it until it stops.
- E. Choke or prime the engine. Start and run engine until it will not start. Operate primer, if equipped on machine, several times to ensure no fuel remains in primer system.
- F. Dispose of fuel properly. Recycle as per local codes.

**Important** Do not store stabilizer/conditioned gasoline over 90 days.

12. Remove the spark plug(s) and check its condition; refer to Spark Plug, page 36. With the spark plug(s) removed from the engine, pour two tablespoons of engine oil into the spark plug hole. Now use the starter to crank the engine and distribute the oil inside the cylinder. Install the spark plug(s). Do not install the wire on the spark plug(s).
13. Check and tighten all bolts, nuts, and screws. Repair or replace any part that is damaged or defective.
14. Paint all scratched or bare metal surfaces. Paint is available from your Authorized Service Dealer.
15. Store the machine in a clean, dry garage or storage area. Remove the key from the ignition switch and keep it in a memorable place out of reach of children or other unauthorized users. Cover the machine to protect it and keep it clean.

**Important** Refer to your engine operator's manual for additional maintenance procedures.

# Troubleshooting

Problem	Possible Causes	Corrective Action
Starter does not crank	<ol style="list-style-type: none"> <li>1. Blade control (PTO) is ENGAGED.</li> <li>2. Parking brake is not on.</li> <li>3. Operator is not seated.</li> <li>4. Battery is dead.</li> <li>5. Electrical connections are corroded or loose.</li> <li>6. Fuse is blown.</li> <li>7. Relay or switch is defective.</li> </ol>	<ol style="list-style-type: none"> <li>1. Move blade control (PTO) to DISENGAGED.</li> <li>2. Set parking brake.</li> <li>3. Sit on the seat.</li> <li>4. Charge the battery.</li> <li>5. Check electrical connections for good contact.</li> <li>6. Replace fuse.</li> <li>7. Contact Authorized Service Dealer.</li> </ol>
Engine will not start, starts hard, or fails to keep running.	<ol style="list-style-type: none"> <li>1. Fuel tank is empty.</li> <li>2. Choke is not ON.</li> <li>3. Air cleaner is dirty.</li> <li>4. Spark plug wires is loose or disconnected.</li> <li>5. Spark plugs are pitted, fouled, or gap is incorrect.</li> <li>6. Dirt in fuel filter.</li> <li>7. Dirt, water, or stale fuel is in fuel system.</li> </ol>	<ol style="list-style-type: none"> <li>1. Fill fuel tank with gasoline.</li> <li>2. Move choke lever to ON.</li> <li>3. Clean or replace air cleaner element.</li> <li>4. Install wires on spark plug.</li> <li>5. Install new, correctly gapped spark plugs.</li> <li>6. Replace fuel filter.</li> <li>7. Contact Authorized Service Dealer.</li> </ol>
Engine loses power.	<ol style="list-style-type: none"> <li>1. Engine load is excessive.</li> <li>2. Air cleaner is dirty.</li> <li>3. Oil level in crankcase is low.</li> <li>4. Cooling fins and air passages under engine blower housing are plugged.</li> <li>5. Spark plugs are pitted, fouled, or gap is incorrect.</li> <li>6. Vent in fuel cap is closed.</li> <li>7. Dirt in fuel filter.</li> <li>8. Dirt, water, or stale fuel is in fuel system.</li> </ol>	<ol style="list-style-type: none"> <li>1. Reduce ground speed.</li> <li>2. Clean air cleaner element.</li> <li>3. Add oil to crankcase.</li> <li>4. Remove obstruction from cooling fins and air passages.</li> <li>5. Install new, correctly gapped spark plugs.</li> <li>6. Open vent in fuel cap.</li> <li>7. Replace fuel filter.</li> <li>8. Contact Authorized Service Dealer.</li> </ol>
Engine overheats.	<ol style="list-style-type: none"> <li>1. More coolant is needed.</li> <li>2. (3) air intake screens are dirty.</li> <li>3. Restricted air flow into the engine.</li> <li>4. Radiator fins are dirty.</li> </ol>	<ol style="list-style-type: none"> <li>1. Check and add coolant.</li> <li>2. Clean with every use.</li> <li>3. Inspect and clean the radiator screen with every use.</li> <li>4. Clean the radiator fins.</li> </ol>

<b>Problem</b>	<b>Possible Causes</b>	<b>Corrective Action</b>
	<ol style="list-style-type: none"> <li>5. The crankcase oil level is incorrect.</li> <li>6. The fuel mixture is lean.</li> <li>7. Excessive loading.</li> </ol>	<ol style="list-style-type: none"> <li>5. Fill or drain to the full mark.</li> <li>6. Contact your Authorized Service Dealer.</li> <li>7. Reduce load; use lower ground speed.</li> </ol>
Machine does not drive.	<ol style="list-style-type: none"> <li>1. Traction belt is worn, loose or broken.</li> <li>2. Traction belt is off pulley.</li> <li>3. Hydro fluid level low.</li> </ol>	<ol style="list-style-type: none"> <li>1. Contact Authorized Service Dealer.</li> <li>2. Contact Authorized Service Dealer.</li> <li>3. Add hydro fluid to reservoir.</li> </ol>
Abnormal vibration.	<ol style="list-style-type: none"> <li>1. Cutting blade(s) is/are bent or unbalanced.</li> <li>2. Blade mounting bolt is loose.</li> <li>3. Engine mounting bolts are loose.</li> <li>4. Loose engine pulley, idler pulley, or blade pulley.</li> <li>5. Engine pulley is damaged.</li> <li>6. Blade spindle bent.</li> </ol>	<ol style="list-style-type: none"> <li>1. Install new cutting blade(s).</li> <li>2. Tighten blade mounting bolt.</li> <li>3. Tighten engine mounting bolts.</li> <li>4. Tighten the appropriate pulley.</li> <li>5. Contact Authorized Service Dealer.</li> <li>6. Contact Authorized Service Dealer.</li> </ol>
Uneven cutting height.	<ol style="list-style-type: none"> <li>1. Blade(s) not sharp.</li> <li>2. Cutting blade(s) is/are bent.</li> <li>3. Mower is not level.</li> <li>4. Gage wheel not set correctly.</li> <li>5. Underside of mower is dirty.</li> <li>6. Tire pressure is incorrect.</li> <li>7. Blade spindle bent.</li> </ol>	<ol style="list-style-type: none"> <li>1. Sharpen blade(s).</li> <li>2. Install new cutting blade(s).</li> <li>3. Level mower from side-to-side and front-to-rear.</li> <li>4. Adjust gage wheel height.</li> <li>5. Clean the underside of the mower.</li> <li>6. Adjust tire pressure.</li> <li>7. Contact Authorized Service Dealer.</li> </ol>
Blades do not rotate.	<ol style="list-style-type: none"> <li>1. Drive belt is worn, loose or broken.</li> <li>2. Drive belt is off pulley.</li> <li>3. Deck belt is worn, loose or broken.</li> <li>4. Deck belt is off pulley.</li> </ol>	<ol style="list-style-type: none"> <li>1. Install new drive belt.</li> <li>2. Install drive belt and check adjusting shafts and belt guides for correct position.</li> <li>3. Install new deck belt.</li> <li>4. Install deck pulley and check the idler pulley, idler arm and spring for correct position and function.</li> </ol>





LCE

# The Toro Total Coverage Guarantee

## A One-Year Limited Warranty

### Conditions and Products Covered

The Toro Company and its affiliate, Toro Warranty Company, pursuant to an agreement between them, jointly promise to repair any Toro Product used for commercial, institutional, or rental purposes if defective in materials or workmanship. The following time periods apply from the date of purchase:

<u>Products</u>	<u>Warranty Period</u>
• All Products	1 year
• All Spindles	2 years parts & labor, third year parts only
• Engines* on the following:	2 years
Out Front and MidMount Zero Radius Tractors	
ProLine Mid-Size Mowers	
Groundsmaster Riding Mowers	
ProLine Hand Held Gas Products (AE and LE engines only)	
Backpack Blowers	

This warranty includes the cost of parts and labor, but you must pay transportation costs.

This warranty applies to:

- Z-Master Zero Radius Tractors
- ProLine Mid-Size Mowers
- Groundsmaster Riding Mowers
- Turf Maintenance Equipment
- Debris Management Equipment

\* Some engines used on Toro LCE Products are warranted by the engine manufacturer.

### Instructions for Obtaining Warranty Service

Should you feel your Toro Product contains a defect in materials or workmanship, contact the dealer who sold you the product or any Authorized Service Dealer or Master Service Dealer. The Yellow Pages of your telephone directory is a good reference source. The dealer will either arrange service at his/her dealership or recommend another Authorized Service Dealer who may be more convenient. You may need proof of purchase (copy of registration card, sales receipt, etc.) for warranty validation.

### Countries Other than the United States or Canada

Customers who have purchased Toro products exported from the United States or Canada should contact their Toro Distributor (Dealer) to obtain guarantee policies for your country, province, or state. If for any reason you are dissatisfied with your Distributor's service or have difficulty obtaining guarantee information, contact the Toro importer. If all other remedies fail, you may contact us at Toro Warranty Company.

If for any reason you are dissatisfied with the Service Dealer's analysis of the defect in materials or workmanship or if you need a referral to a Toro Service Dealer, please feel free to contact us at:

LCB Customer Service Department  
Toro Warranty Company  
8111 Lyndale Avenue South  
Bloomington, MN 55420-1196  
952-888-8801 or 888-577-7466

### Owner Responsibilities

You must maintain your Toro Product by following the maintenance procedures described in the operator's manual. Such routine maintenance, whether performed by a dealer or by you, is at your expense.

### Items and Conditions Not Covered

There is no other express warranty except for special emission system coverage on some products. This express warranty does not cover:

- Cost of regular maintenance service or parts, such as filters, fuel, lubricants, tune-up parts, blade sharpening, brake and clutch adjustments.
- Any product or part which has been altered or misused or required replacement or repair due to normal wear, accidents, or lack of proper maintenance.
- Repairs necessary due to improper fuel, contaminants in the fuel system, or failure to properly prepare the fuel system prior to any period of non-use over three months.
- Pickup and delivery charges.

All repairs covered by this warranty must be performed by an Authorized Toro Service Dealer using Toro approved replacement parts.

### General Conditions

Repair by an Authorized Toro Service Dealer is your sole remedy under this warranty.

Neither The Toro Company nor Toro Warranty Company is liable for indirect, incidental or consequential damages in connection with the use of the Toro Products covered by this warranty, including any cost or expense of providing substitute equipment or service during reasonable periods of malfunction or non-use pending completion of repairs under this warranty. Some states do not allow exclusions of incidental or consequential damages, or limitations on how long an implied warranty lasts, so the above exclusions and limitations may not apply to you.

This warranty gives you specific legal rights, and you may also have other rights which vary from state to state.