



265H

Wheel Horse[®] Lawn and Garden Tractor

Model No. 72051—220000001 & Up

Operator's Manual



Warning



The engine exhaust from this product contains chemicals known to the State of California to cause cancer, birth defects, or other reproductive harm.

Important The engine in this product is not equipped with a spark arrester muffler. It is a violation of California Public Resource Code Section 4442 to use or operate this engine on any forest-covered, brush-covered, or grass-covered land as defined in CPRC 4126. Other states or federal areas may have similar laws.

The enclosed Engine Owner's Manual is supplied for information regarding The U.S. Environmental Protection Agency (PEA) and the California Emission Control Regulation of emission systems, maintenance and warranty.

Keep this engine Owner's Manual with your unit. Should this engine Owner's Manual become damaged or illegible, replace immediately. Replacements may be ordered through the engine manufacturer.

This spark ignition system complies with Canadian ICES-002.

Ce système d'allumage par étincelle de véhicule est conforme à la norme NMB-002 du Canada.

Contents

	Page
Introduction	2
Safety	3
Safe Operating Practices	3
Toro Riding Mower Safety	4
Slope Chart	7
Safety and Instruction Decals	9
Gasoline and Oil	12
Recommended Gasoline	12
Stabilizer/Conditioner	12
Filling the Fuel Tank	12
Check Engine Oil Level	12
Setup	13
Loose Parts	13
Checking the Tire Pressure	13
Activating the Battery	13
Checking the Engine Oil	14
Checking the Tractor Lubrication	14
Operating the Tractor	14
Checking the Safety Interlock System	14
Test Driving the Tractor	14

	Page
Operation	15
Think Safety First	15
Controls	15
Using the Parking Brake	15
Starting and Stopping the Engine	15
Operating the Power Take Off (PTO)	16
Checking the Safety Interlock System	16
Indicator Control Module	18
Driving Forward or Backward	19
Stopping the Machine	19
Using the Attachment Lift Lever	19
Adjusting the Dial-A-Height	20
Positioning the Seat	20
Using the Headlights	20
Positioning the Tilt Steering Wheel	20
Using the Cruise Control	21
Pushing the Machine by Hand	21
Maintenance	22
Recommended Maintenance Schedule	22
Servicing the Air Cleaner	23
Servicing the Engine Oil	24
Servicing the Spark Plug	25
Greasing and Lubrication	26
Checking the Tire Pressure	27
Servicing the Brake	27
Servicing the Fuel Tank	28
Servicing the Fuel Filter	28
Adjusting the Front Wheel Toe-In	29
Servicing the Transaxle Fluid	30
Servicing the Fuse	30
Servicing the Headlights	30
Servicing the Battery	31
Wiring Diagram	34
Cleaning and Storage	35
Troubleshooting	36
The Toro Total Coverage Guarantee	40

Introduction

Read this manual carefully to learn how to operate and maintain your product properly. The information in this manual can help you and others avoid injury and product damage. Although Toro designs and produces safe products, you are responsible for operating the product properly and safely.

Whenever you need service, genuine Toro parts, or additional information, contact an Authorized Service Dealer or Toro Customer Service and have the model and

serial numbers of your product ready. Figure 1 illustrates the location of the model and serial numbers on the product.

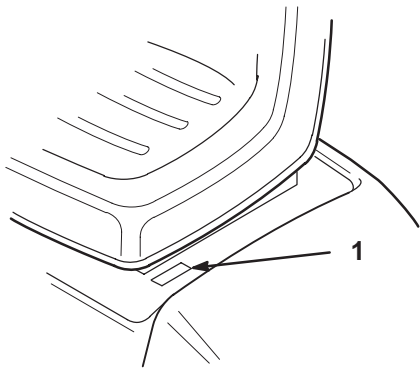

m-2345

Figure 1

1. Location of the model and serial numbers

Write the product model and serial numbers in the space below:

Model No. _____
Serial No. _____

This manual identifies potential hazards and has special safety messages that help you and others avoid personal injury and even death. **Danger**, **Warning**, and **Caution** are signal words used to identify the level of hazard. However, regardless of the hazard, be extremely careful.

Danger signals an extreme hazard that *will* cause serious injury or death if you do not follow the recommended precautions.

Warning signals a hazard that *may* cause serious injury or death if you do not follow the recommended precautions.

Caution signals a hazard that may cause minor or moderate injury if you do not follow the recommended precautions.

This manual uses two other words to highlight information. **Important** calls attention to special mechanical information and **Note**: emphasizes general information worthy of special attention.

Safety

This machine meets or exceeds the B71.1–1998 specifications of the American National Standards Institute, in effect at the time of production. However, improper use or maintenance by the operator or owner can result in injury. To reduce the potential for injury, comply with these safety instructions and always pay

attention to the safety alert  symbol, which means CAUTION, WARNING, or DANGER—“personal safety instruction.” Failure to comply with the instruction may result in personal injury or death.

Safe Operating Practices

The following instructions are from ANSI standard B71.1–1998.

This product is capable of amputating hands and feet and throwing objects. Always follow all safety instructions to avoid serious injury or death.

General Operation

- Read, understand, and follow all instructions in the operator’s manual and on the machine before starting.
- Allow only responsible adults who are familiar with the instructions to operate the machine.
- Clear the area of objects such as rocks, toys, wire, etc., which could be picked up and thrown by the blade.
- Be sure the area is clear of other people before mowing. Stop the machine if anyone enters the area.
- Never carry passengers.
- Do not mow in reverse unless absolutely necessary. Always look down and behind before and while backing.
- Be aware of the mower discharge direction and do not point it at anyone. Do not operate the mower without either the entire grass catcher or the guard in place.
- Slow down before turning.
- Never leave a running machine unattended. Always turn off blades, set parking brake, stop engine, and remove keys before dismounting.
- Turn off blades when not mowing.
- Stop the engine before removing the grass catcher or unclogging the chute.
- Mow only in daylight or good artificial light.
- Do not operate the machine while under the influence of alcohol or drugs.
- Watch for traffic when operating near or crossing roadways.
- Use extra care when loading or unloading the machine into a trailer or truck.
- Always wear safety goggles or safety glasses with side shields when operating mower.

- Data indicates that operators, age 60 years and above, are involved in a large percentage of riding mower-related injuries. These operators should evaluate their ability to operate the riding mower safely enough to protect themselves and others from serious injury.

Slope Operation

Slopes are a major factor related to loss-of-control and tip-over accidents, which can result in severe injury or death. All slopes require extra caution. If you cannot back up the slope or if you feel uneasy on it, do not mow it.

- Mow up and down slopes, not across.
- Remove obstacles such as rocks, tree limbs, etc.
- Watch for holes, ruts or bumps. Uneven terrain could overturn the machine. Tall grass can hide obstacles.
- Use slow speed. Choose a low gear so that you will not have to stop or shift while on the slope.
- Follow Toro's recommendations for wheel weight or counterweights to improve stability.
- Use extra care with grass catchers or other attachments. These can change the stability of the machine.
- Keep all movement on slopes slow and gradual. Do not make sudden changes in speed or direction.
- Avoid starting or stopping on a slope. If tires lose traction, disengage the blades and proceed slowly straight down the slope.
- Do not turn on slopes unless necessary, and then, turn slowly and gradually downhill, if possible.
- Do not mow near drop-offs, ditches, or embankments. The machine could suddenly turn over if a wheel goes over the edge of a cliff or ditch, or if an edge caves in.
- Do not mow on wet grass. Reduced traction could cause sliding.
- Do not try to stabilize the machine by putting your foot on the ground.
- Do not use a grass catcher on steep slopes.

Children

Tragic accidents can occur if the operator is not alert to the presence of children. Children are often attracted to the machine and the mowing activity. Never assume that children will remain where you last saw them.

- Keep children out of the mowing area and under the watchful care of another responsible adult.
- Be alert and turn the machine off if children enter the area.

- Before and while backing, look behind and down for small children.
- Never carry children, even with the blades off. They may fall off and be seriously injured or interfere with safe machine operation.
- Never allow children to operate the machine.
- Use extra care when approaching blind corners, shrubs, trees, the end of a fence or other objects that may obscure vision.

Service

- Use extra care when handling gasoline and other fuels. They are flammable and vapors are explosive.
 - A. Use only an approved container.
 - B. Never remove the gas cap or add fuel when the engine is running. Allow the engine to cool before refueling. Do not smoke.
 - C. Never refuel the machine indoors.
 - D. Never store the machine or fuel container inside where there is an open flame, such as near a water heater or furnace.
- Never run a machine inside a closed area.
- Keep nuts and bolts tight, especially the blade attachment bolts. Keep equipment in good condition.
- Never tamper with safety devices. Check their proper operation regularly.
- Keep the machine free of grass, leaves, or other debris build-up. Clean up oil or fuel spillage. Allow the machine to cool before storing.
- Stop and inspect the equipment if you strike an object. Repair, if necessary, before restarting.
- Grass catcher components are subject to wear, damage and deterioration, which could expose moving parts or allow objects to be thrown. Frequently check components and replace with manufacturer's recommended parts, when necessary.
- Mower blades are sharp and can cut. Wrap the blade(s) or wear gloves, and use extra caution when servicing them.
- Use only genuine Toro replacement parts to ensure that original standards are maintained.

Toro Riding Mower Safety

The following list contains safety information specific to Toro products or other safety information that you must know that is not included in the ANSI standards.



Warning



Engine exhaust contains carbon monoxide, which is an odorless, deadly poison that can kill you. It is also known to the State of California to cause birth defects.

Do not run engine indoors or in an enclosed area.

- Stop the engine, disconnect spark plug wire(s) and remove key before performing any service, repairs, maintenance or adjustments.
- Slow down before turning. Sharp turns on any terrain may cause loss of control.
- Never leave a running machine unattended. Always turn off blades, set parking brake, stop engine, and remove the ignition and KeyChoice™ keys before dismounting.
- Keep hands, feet, hair and loose clothing away from attachment discharge area, underside of mower and any moving parts while engine is running.
- Do not touch equipment or attachment parts which may be hot from operation. Allow to cool before attempting to maintain, adjust or service.
- Battery acid is poisonous and can cause burns. Avoid contact with skin, eyes and clothing. Protect your face, eyes and clothing when working with a battery.
- Battery gases can explode. Keep cigarettes, sparks and flames away from battery.
- Use only genuine replacement parts to ensure that original standards are maintained.
- Use only Toro approved attachments. Warranty may be voided if used with unapproved attachments.
- Do not mow across slopes exceeding 5 degrees.
- Do not mow down slopes exceeding 15 degrees.
- Do not mow up slopes exceeding 10 degrees.
- If a steep slope must be ascended, back up the hill, and drive forward down the hill, keeping the machine in gear.
- Avoid turning on slopes. If you must turn, turn slowly and gradually downhill, if possible.
- Do not use a grass catcher on steep slopes. Heavy grass bags could cause loss of control or overturn the machine.

Slope Chart

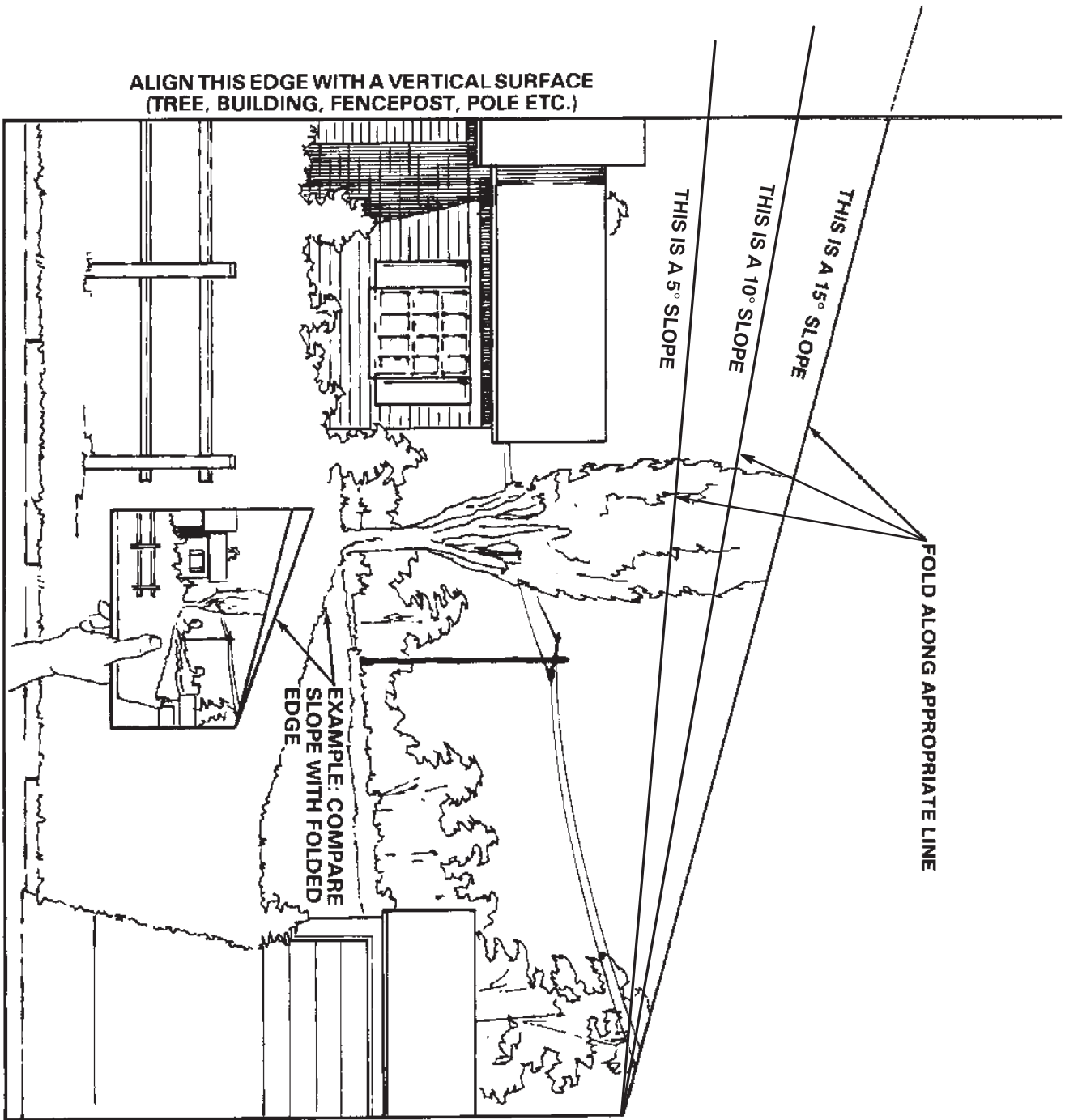

Safety and Instruction Decals



Safety decals and instructions are easily visible to the operator and are located near any area of potential danger. Replace any decal that is damaged or lost.

⚠ DANGER

TO AVOID SERIOUS INJURY OR DEATH,
 • READ AND UNDERSTAND THE OPERATOR'S MANUAL.
 • KNOW LOCATION AND FUNCTION OF CONTROLS.
 • NEVER USE WHEN UNDER THE INFLUENCE OF ALCOHOL OR DRUGS.
 • USE SAFELY; MACHINE IS NOT A TOY; NEVER LET CHILDREN OPERATE.
 • GO UP AND DOWN SLOPES, NOT ACROSS.
 • AVOID SHARP OR SUDDEN TURNS AND SLIPPERY OR STEEP AREAS.
 • IF MACHINE STOPS GOING UPHILL, STOP BLADE AND BACK SLOWLY DOWN.
 • NEVER MOW WHEN CHILDREN OR OTHERS ARE IN THE MOWING AREA.
 • NEVER CARRY CHILDREN OR OTHER PASSENGERS.
 • LOOK DOWN AND BEHIND BEFORE AND WHILE BACKING UP.
 • KEEP SAFETY DEVICES IN PLACE AND WORKING; CHECK BEFORE EACH USE.
 • SAFETY INTERLOCKS CAN FAIL; NEVER ASSUME BLADE IS STOPPED.
 • STOP ENGINE, SET PARKING BRAKE AND REMOVE KEY IF LEAVING MACHINE.
 • REMOVE OBJECTS THAT COULD BE THROWN BY THE BLADE.

NEVER MOW SIDE HILL OVER 5°
 5°

NEVER MOW UP HILL OVER 10°
 10°

NEVER MOW DOWN HILL OVER 15°
 15°

HYDRO DRIVE PEDAL
 REVERSE NEUTRAL FORWARD

BRAKE PEDAL
 BRAKE PEDAL

(P) PARKING BRAKE
 ON OFF

TO SET
 DEPRESS BRAKE PEDAL AND LIFT LEVER

TO RELEASE
 DEPRESS BRAKE PEDAL

93-0302

93-0302

TO OPERATE TRACTOR
 MOVE LEVER FORWARD
 MOVE LEVER FORWARD
TO PUSH TRACTOR
 LEVER MUST BE IN REARWARD POSITION
 LEVER MUST BE IN REARWARD POSITION
DO NOT TOW

92-6726

92-6726

⚠ DANGER

• ROTATING BLADES CAN CUT OFF ARMS AND LEGS.
• NEVER MOW WHEN CHILDREN ARE NEAR.
• NEVER CARRY RIDERS; THEY FALL OFF.

92-8946

92-8946

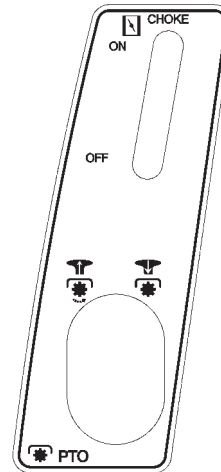

92-6720

DOWN

LIFT

UP

112168

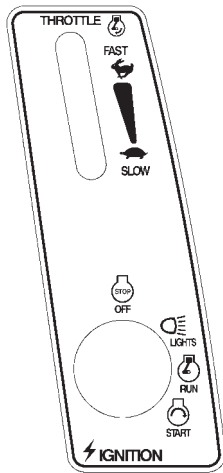

92-6721

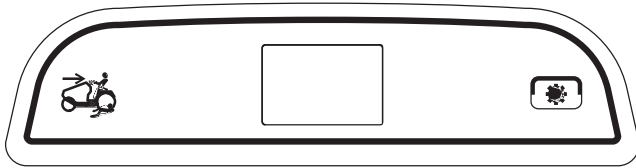

99-8038

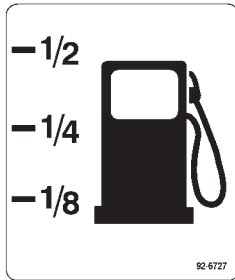

92-6727

 **READ YOUR OPERATOR'S MANUAL FOR OPERATING AND SAFETY INSTRUCTIONS. TO GET A REPLACEMENT MANUAL, SEND MODEL AND SERIAL NUMBERS TO: THE TORO CO., 8111 LYNDALE AVE. S., BLOOMINGTON, MN 55420-1196 83-6620**

83-6620

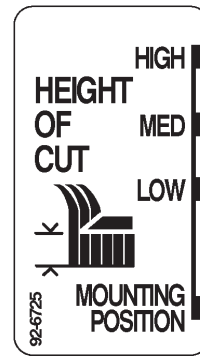

92-6725



78-9740

⚠ DANGER
NEVER MOW IN REVERSE IF THERE IS ANY POSSIBILITY OF CHILDREN APPEARING IN THE MOWING AREA. 99-2985

99-2985

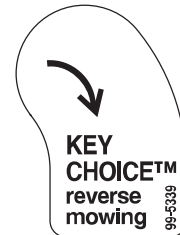

99-5339A

NO. ⚠

See important warning information on side label!
Voir information d'avertissement importante sur l'étiquette de côté!
¡Aviso importante favor de observar las instrucciones en la etiqueta lateral!



104-4163

MAINTENANCE FREE • SANS ENTRETIEN • LIBRE DE MANTENIMIENTO

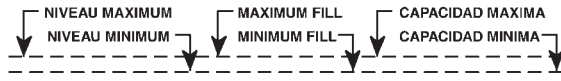

⚠ DANGER/POISON ¡PELIGRO/VENENO!

<p>SHIELD EYES. EXPLOSIVE GASES CAN CAUSE BLINDNESS OR INJURY.</p> <p>PROTÉGER LES YEUX. GAZ EXPLOSIFS PEUVENT RENDRE AVEUGLE OU PROVOQUER DES LÉSIONS.</p> <p>PROTEJA LOS OJOS. GASES EXPLOSIVOS PUEDEN CAUSAR CEGUERA O DAÑO.</p>	<p>NO • SPARKS • FLAMES • SMOKING</p> <p>ÉLOIGNER • ÉTINCELLES • FLAMMES • CIGARETTES</p> <p>NO • CHISPAS • FLAMAS • FUMAR</p>	<p>SULFURIC ACID CAN CAUSE BLINDNESS OR SEVERE BURNS.</p> <p>ACIDE SULFURIQUE PEUT RENDRE AVEUGLE OU PROVOQUER DES BRULURES GRAVES.</p> <p>ACIDO SULFURICO PUEDA CAUSAR CEGUERA O QUEMADURAS SEVERAS.</p>	<p>FLUSH EYES IMMEDIATELY WITH WATER. GET MEDICAL HELP FAST.</p> <p>RINCER IMMEDIATEMENT LES YEUX A GRANDE EAU. CONTACTER RAPIDEMENT UN MEMBRE DE LA PROFESSION MEDICALE.</p> <p>LAVE LOS OJOS DE INMEDIATO. CONSIGA AYUDA MEDICA RAPIDO.</p>
--------------------------------------------------------------------------------------------------------------------------------------------------------------------------------------------------------------------------------------------------------------	-----------------------------------------------------------------------------------------------------------------------------------------------------------------------------------------	--------------------------------------------------------------------------------------------------------------------------------------------------------------------------------------------------------------------------------------------	--------------------------------------------------------------------------------------------------------------------------------------------------------------------------------------------------------------------------------------------------------------------

KEEP OUT OF THE REACH OF CHILDREN. DO NOT TIP. DO NOT OPEN BATTERY!
MAINTENIR HORS DE LA PORTÉE DES ENFANTS. NE RENVARSEZ PAS. N'OUVREZ PAS LA BATTERIE!
MANTENGASE FUERA DEL ALCANCE DE LOS NIÑOS. NO INCLINE. NO ABRA LA BATERIA!

- HOW TO ACTIVATE DRY CHARGED BATTERIES**
- Use only battery electrolyte (1.265 Sp.Gr.) to fill battery initially.
 - Do not overfill. Let stand for 15 minutes.
 - Charge battery at 4-5 amps until specific gravity is 1.250 or higher and temperature is at least 60°F. - all cells gassing freely.
 - After battery has been activated, add only water to replace normal loss.



3-4915 Dist. by:/por:/par: EPM Products, Baltimore, MD 21226 MADE IN U.S.A. • FABRIQUE AUX E.U.A. • HECHO EN E.U.A.

104-5091

260 SERIES QUICK REFERENCE AID

SEE OPERATOR'S MANUAL

MODEL NUMBER	72051/ 265-H	72052/ 266-H	72107/ 268-H	72108/ 270-H
PART NUMBERS				
DRIVE/TRANS BELT	100-3469	100-3469	100-3469	100-3469
OIL FILTER	12 050 01	12 050 01	12 050 01	12 050 01
AIR ELEMENT	12 083 05	12 083 05	47 083 03	47 083 03
AIR PRE-CLEANER	12 083 08	12 083 08	24 083 02	24 083 02
SPARK PLUG	12 132 02	12 132 02	12 132 02	12 132 02
FUEL FILTER	25 050 02	25 050 02	25 050 02	25 050 02
MOWER MODEL NUMBERS- MOWER DRIVE BELT	78215 - 36" 78-3668	78251 - 42" 92-6868	78261 - 43" 92-6968	78261 - 52" 94-4368
SUGGESTED MAINTENANCE				
A. ENGINE OIL*	CHECK LEVEL SERVICED FREQUENTLY	CHANGE	50 FILTER	100 HRS
B. GREASE CHARGES	98490 / STORAGE SERVICE			
C. FUEL AIR CLEANER SERVICE	98495 / STORAGE SERVICE			
D. BATTERY	98496 / STORAGE SERVICE / SPRING SERVICE			
E. TRANSMISSION FLUID	148494 / STORAGE SERVICE / SPRING SERVICE			

KOHLER engines

PERFORM ALL SCHEDULED MAINTENANCE SOON AFTER 40 HOURS, OR AT 100 HOURS.

For complete maintenance schedules refer to your Toro Wheel Horse Owners Manual.

For dealer locator and more information on Toro products, contact:
www.toro.com

104-5059

Gasoline and Oil

Recommended Gasoline

Use UNLEADED Regular Gasoline suitable for automotive use (85 pump octane minimum). Leaded regular gasoline may be used if unleaded regular is not available.

Important Never use methanol, gasoline containing methanol, or gasohol containing more than 10% ethanol because the fuel system could be damaged. Do not mix oil with gasoline.



Danger



In certain conditions, gasoline is extremely flammable and highly explosive. A fire or explosion from gasoline can burn you and others and can damage property.

- Fill the fuel tank outdoors, in an open area, when the engine is cold. Wipe up any gasoline that spills.
- Do not fill the fuel tank completely full. Add gasoline to the fuel tank until the level is 1/4" to 1/2" (6 mm to 13 mm) below the bottom of the filler neck. This empty space in the tank allows gasoline to expand.
- Never smoke when handling gasoline, and stay away from an open flame or where gasoline fumes may be ignited by a spark.
- Store gasoline in an approved container and keep it out of the reach of children. Never buy more than a 30-day supply of gasoline.
- Always place gasoline containers on the ground away from your vehicle before filling.
- Do not fill gasoline containers inside a vehicle or on a truck or trailer bed because interior carpets or plastic truck bed liners may insulate the container and slow the loss of any static charge.
- When practical, remove gas-powered equipment from the truck or trailer and refuel the equipment with its wheels on the ground.
- If this is not possible, then refuel such equipment on a truck or trailer from a portable container, rather than from a gasoline dispenser nozzle.
- If a gasoline dispenser nozzle must be used, keep the nozzle in contact with the rim of the fuel tank or container opening at all times until fueling is complete.

Stabilizer/Conditioner

Using a stabilizer/conditioner in the machine:

- Keeps gasoline fresh during storage of 90 days or less. For longer storage it is recommended that the fuel tank be drained.
- Cleans the engine while it runs
- Eliminates gum-like varnish buildup in the fuel system, which causes hard starting

Important Never use fuel additives containing methanol or ethanol.

Add the correct amount of gas stabilizer/conditioner to the gas.

Note: A fuel stabilizer/conditioner is most effective when mixed with fresh gasoline. To minimize the chance of varnish deposits in the fuel system, use fuel stabilizer at all times.

Filling the Fuel Tank

1. Shut the engine off and set the parking brake.
2. Clean around each fuel tank cap and remove the cap. Add unleaded regular gasoline to both fuel tanks, until the level is 1/4 to 1/2 inch (6 mm to 13 mm) below the bottom of the filler neck. This space in the tank allows gasoline to expand. Do not fill the fuel tanks completely full.
3. Install fuel tank cap securely. Wipe up any gasoline that may have spilled.

Check Engine Oil Level

Before you start the engine and use the machine, check the oil level in the engine crankcase; refer to Checking Oil Level, page 24.

Setup

Note: Determine the left and right sides of the machine from the normal operating position.

Loose Parts

Note: Use the chart below to identify parts for assembly.

DESCRIPTION	QTY.	USE
Bolt, 1/4 x 3/4	2	Activating the battery
Washer	2	
Locknut	2	
Key	1	Use in ignition switch
Operator's Manual	1	Read manual before operating tractor

Checking the Tire Pressure

Check front and rear tire pressure.

Pressure: 20 psi (138 kPa) front and rear.

Activating the Battery

Note: Bulk electrolyte with 1.265 specific gravity must be purchased from a local battery supply outlet.

⚠
Danger
⚠

Battery electrolyte contains sulfuric acid which is a deadly poison and causes severe burns.

- Do not drink electrolyte and avoid contact with skin, eyes or clothing. Wear safety glasses to shield your eyes and rubber gloves to protect your hands.
- Fill the battery where clean water is always available for flushing the skin.
- Follow all instructions and comply with all safety messages on the electrolyte container.

1. Remove the battery from the tractor.
 2. Clean the top of the battery with a paper towel.
- Note:** Never fill the battery with electrolyte while the battery installed in the tractor. Electrolyte could be spilled on other parts and cause corrosion.
3. Remove the vent caps from the battery (Fig. 2).

4. Slowly pour electrolyte into each battery cell until the level is up to the upper line (Fig. 2) on the battery case.

Important Do not overfill the battery because electrolyte (sulfuric acid) can cause severe corrosion and damage to the chassis.

5. Wait five to ten minutes after filling the battery cells. Add electrolyte, if necessary, until the electrolyte level is up to the upper line on the battery case (Fig. 2).
6. Reinstall battery filler caps.

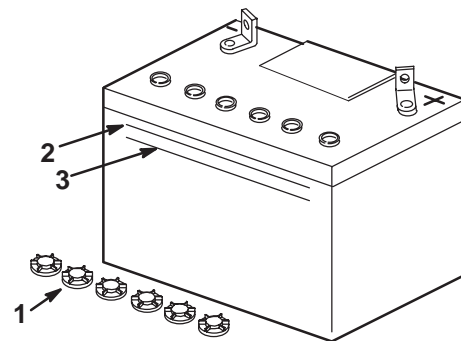

Figure 2

1. Filler caps
2. Upper line
3. Lower line

7. Charge the battery. Refer to Charging the Battery on page 33.
8. When the battery is fully charged, unplug the charger from the electrical outlet, then disconnect the charger leads from the battery posts (Fig. 3).

m-5004

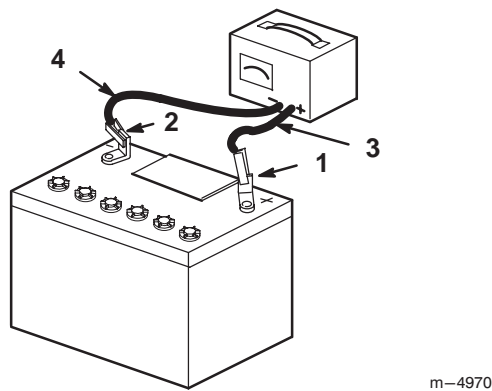

Figure 3

- | | |
|--------------------------|---------------------------|
| 1. Positive Battery Post | 3. Red (+) Charger Lead |
| 2. Negative Battery Post | 4. Black (-) Charger Lead |

9. Install the battery in the tractor and connect the battery cables. Refer to the Installing the Battery on page 32.

Note: Do not run the tractor with the battery disconnected, electrical damage may occur.

Checking the Engine Oil

Important The tractor is shipped from the factory with oil in the engine.

Check the oil level and add only enough oil to raise the level to the full mark on the dipstick. Refer to Checking the Engine Oil on page 24.

Checking the Tractor Lubrication

Check the tractor to ensure it is lubricated. Refer to Greasing and Lubrication on page 26.

Operating the Tractor

Learn how to operate the tractor. Read the Operation section starting on page 15.

Checking the Safety Interlock System

	Caution	
<p>If safety interlock switches are disconnected or damaged the machine could operate unexpectedly causing personal injury.</p> <ul style="list-style-type: none"> • Do not tamper with the interlock switches. • Check the operation of the interlock switches daily and replace any damaged switches before operating the machine. 		

Refer to Checking the Safety Interlock System on page 16.

Test Driving the Tractor

Make sure all electrical and mechanical systems are operating properly.

Operation

Think Safety First

Please carefully read all the safety instructions on pages 3–9. Knowing this information could help you, your family, pets or bystanders avoid injury.

Controls

Become familiar with all the controls (Fig. 1) before you start the engine and operate the machine.

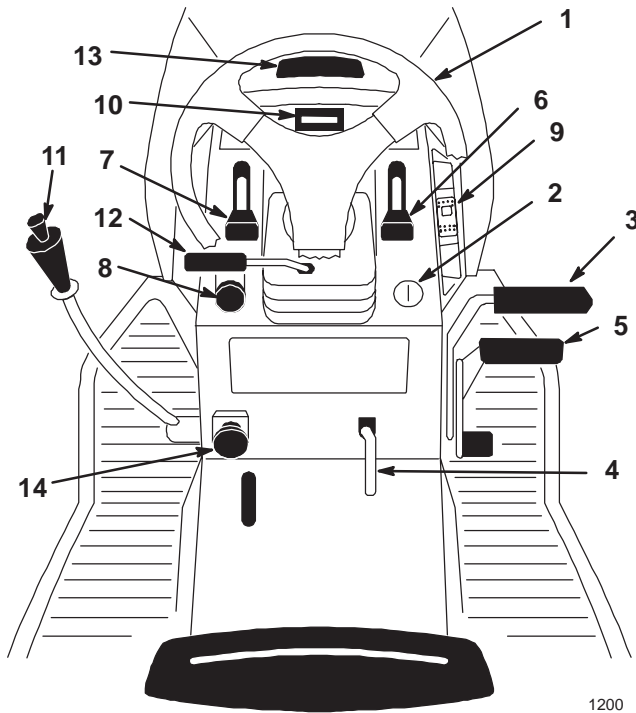

Figure 1

- | | |
|---------------------------|----------------------------------------|
| 1. Steering wheel | 9. Cruise control switch |
| 2. Ignition switch | 10. Indicator control module/Hourmeter |
| 3. Brake pedal | 11. Attachment lift lever |
| 4. Parking brake lever | 12. Tilt wheel lever |
| 5. Traction control pedal | 13. Hood opening |
| 6. Throttle lever | 14. Dial-a-height knob |
| 7. Choke lever | |
| 8. Power take off (PTO) | |

Using the Parking Brake

Always set the parking brake when you stop the machine or leave it unattended.

Setting the Parking Brake

1. Push the brake pedal (Fig. 2) down and hold it in the depressed position.
2. Lift the parking brake lever (Fig. 2) up and gradually take your foot off the brake pedal. The brake pedal should stay in the depressed (locked) position.

Releasing the Parking Brake

1. Push down on the brake pedal (Fig. 2). The parking brake lever should release.
2. Gradually release the brake pedal.

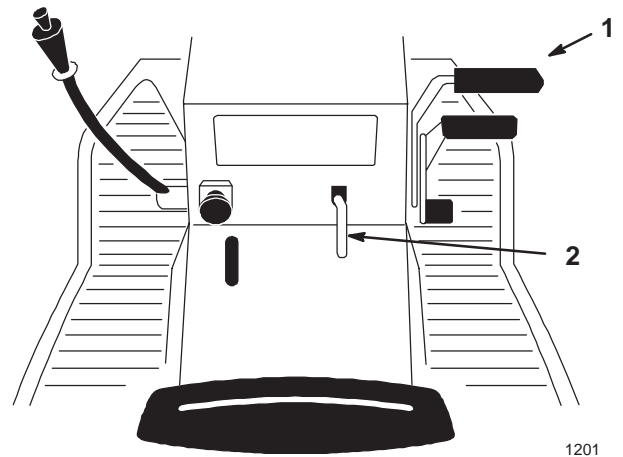

Figure 2

1. Brake pedal
2. Parking brake lever

Starting and Stopping the Engine

Starting the Engine

1. Sit down on the seat.
2. Set the parking brake; refer to Setting the Parking Brake, page 15.

Note: The engine will not start unless you set the parking brake or fully depress the brake pedal and are seated.

3. Push the PTO (power take off) to off (Fig. 3).
4. Move the choke lever to on (Fig. 3).

Note: An engine that has been running and is warm may not require step 4.

5. Move throttle lever to fast (Fig. 4).

- Turn the ignition key and hold it in the start position (Fig. 5). When the engine starts, release the key.

Important If the engine does not start after 10 seconds of continuous cranking, turn the ignition key to off and let the starter motor cool for 60 seconds. Refer to Troubleshooting on page 36.

- After the engine starts, move the choke lever to off. Slowly move the throttle to the desired setting (Fig. 4). If the engine stalls or hesitates, move the choke lever back to on for a few seconds. Then move the throttle lever to desired setting. Repeat this as required.

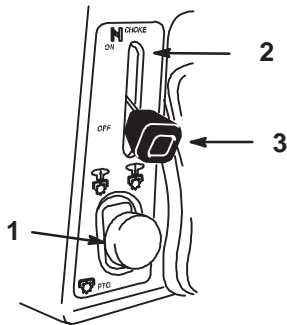

1206

Figure 3

- PTO—Off
- Choke—On
- Choke—Off

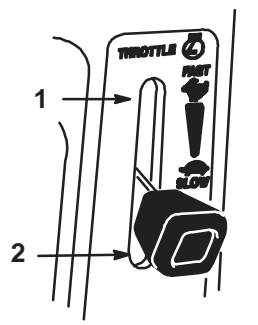

1207

Figure 4

- Fast
- Slow

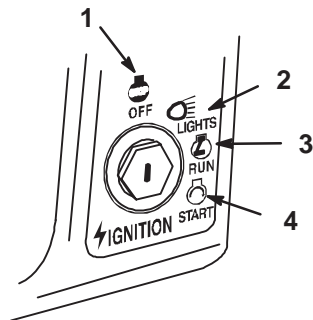

1208

Figure 5

- Off
- Lights
- Run
- Start

Stopping the Engine

- Push the PTO (power take off) to off (Fig. 3).
- Move the throttle lever to slow (Fig. 4).
- Let engine idle for 30–60 seconds.
- Turn the ignition key to off (Fig. 5).

Operating the Power Take Off (PTO)

The power take off (PTO) engages and disengages power to the electric clutch.

The PTO light, in the Indicator Module, will be on when the ignition key is in run or lights position and the power take off (PTO) is engaged. When this light is on it is a reminder the starter will not crank and to turn the off PTO before getting off the tractor.

Engaging the Power Take Off (PTO)

- Depress the brake pedal to stop the machine.
- Pull the power take off (PTO) to on (Fig. 6).

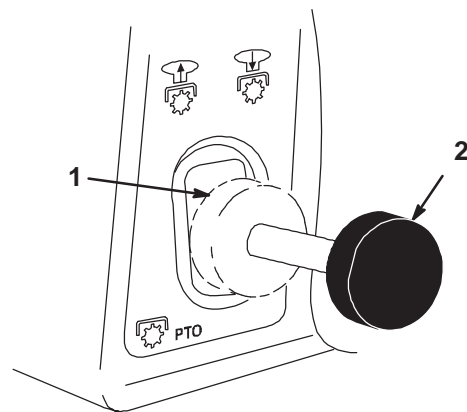

1206

Figure 6

- Off-Disengaged
- On-Engaged

Disengaging the Power Take Off (PTO)

- Depress the brake pedal to stop the machine.
- Push the power take off (PTO) to off (Fig. 6).

Checking the Safety Interlock System



Caution



If safety interlock switches are disconnected or damaged the machine could operate unexpectedly causing personal injury.

- Do not tamper with the interlock switches.
- Check the operation of the interlock switches daily and replace any damaged switches before operating the machine.

Understanding the Safety Interlock System

The safety interlock system is designed to prevent the engine from starting unless:

- You are sitting on the seat
- The brake pedal is depressed
- The power take off (PTO) is off
- The hydro control pedal is in the neutral position.



The safety interlock system is designed to stop the power take off (PTO) if:

- You rise from the seat when the brake pedal is released
- You rise from the seat when the power take off (PTO) is on.
- You move the hydro control pedal out of the neutral position when the parking brake is engaged.
- You shift into reverse with the power take off (PTO) engaged.

Setting the KeyChoice™ Switch to Operate in Reverse

An interlock feature on the tractor prevents the power take off (PTO) from operating when backing up. If you shift into reverse with the PTO engaged (i.e., with mower blades or other attachment running), the PTO will disengage. **Do not mow in reverse unless absolutely necessary.**

If you need to use the PTO while backing up, you can turn off this interlock feature using the KeyChoice switch located near the seat bracket (Fig. 7).

 **Danger** 

You could back over a child or bystander while the mower blade(s) or other attachment is engaged and cause serious injury or death.

- **Do not mow in reverse unless absolutely necessary.**
- **Do not insert the KeyChoice key unless it is absolutely necessary.**
- **Always look backward and down before backing up.**
- **Use the KeyChoice switch only if you are certain no children or other bystanders will enter the mowing area.**
- **Be very observant after deactivating the interlock because the sound of the engine may prevent you from noticing that a child or bystander has entered the work area.**
- **Always remove both the ignition and KeyChoice keys and put them in a safe place out of the reach of children or unauthorized users when leaving the unit unattended.**

1. Engage the PTO.
2. Insert the KeyChoice key into the switch (Fig. 7).

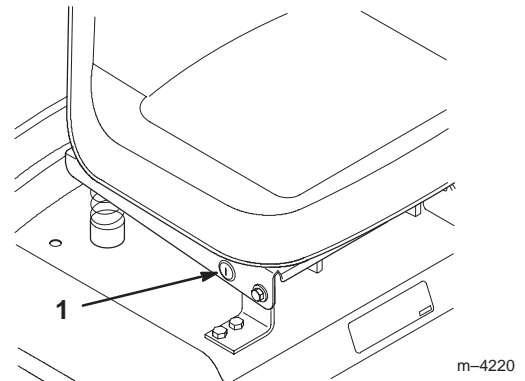

Figure 7

1. KeyChoice switch

3. Turn the KeyChoice key.

A red light on the front console (Fig. 8) turns on, indicating that the interlock is disabled.

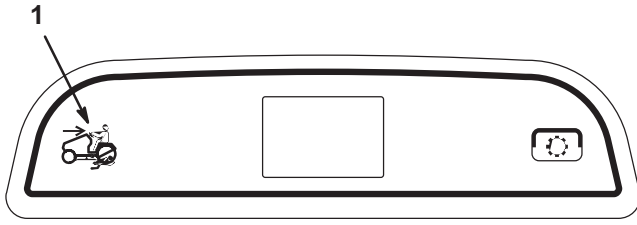

Figure 8

1. Operating-in-reverselight
-
4. Shift into reverse and complete your task.
 5. Stop the PTO of the engine to activate the interlock.
 6. Remove the KeyChoice key and put it in a safe place out of reach of children.

Testing the Safety Interlock System

Test the safety interlock system before you use the machine each time. If the safety system does not operate as described below, have an Authorized Service Dealer repair the safety system immediately.

1. Set the parking brake. Move the power take off (PTO) to **on**. Now turn the ignition key to **start**; **the engine should not crank**.
2. Push the power take off (PTO) to **off** and release the parking brake. Now turn the ignition key to **start**; the engine should not crank.
3. Set the parking brake, move the power take off (PTO) to **off** and move the hydro control pedal forward from the neutral; **the engine should not crank**.
4. Set the parking brake and move the power take off (PTO) to **off**. Now start the engine. While the engine is running, release the parking brake and rise slightly from the seat; **the engine should stop**.
5. Set the parking brake and restart the engine. While the engine is running, and the parking brake is engaged, move the hydro pedal forward; **the engine should stop**.
6. With the parking brake released, turn the ignition key to RUN without starting the engine. Pull the PTO switch to **on**. You should hear an audible click indicating the PTO is activated and the PTO light will illuminate. Move the foot pedal to reverse. You should hear an audible click indicating the PTO is deactivated and the PTO light should turn off.

7. With the parking brake released, turn the ignition switch to RUN without starting the engine. Pull the PTO switch to **on**. Turn the KeyChoice key and release. The Operating-in-Reverse warning light should illuminate. Move the foot pedal to reverse. The PTO and PTO light on the dash should remain on. Push the PTO switch to **off**. The PTO light and the Operating-in-Reverse warning light should turn off.

Indicator Control Module

The indicator control module (optional on some models) (Fig. 9) lights when the parking brake or power take off (PTO), is actuated and when there is a problem of low oil pressure or alternator output, that needs immediate attention.

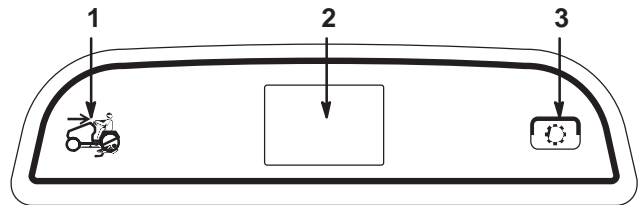

Figure 9

1. Operating-in-Reverse
2. Hourmeter
3. PTO (power take off)

Following are the conditions when indicator lights will be **on**. At other times the lights should be off.

Operating in Reverse

The Operating-in-Reverse light will illuminate whenever the KeyChoice switch is used to deactivate the operating-in-reverse interlock. It is a reminder that the interlock system is deactivated. The light goes out whenever the power take off (PTO) is disengaged or the engine is shut off.

Hourmeter

The hourmeter (optional on some models) records the number of hours the engine has operated (Fig. 9). It is turned on when the ignition switch is in the run or lights positions. Use the times for scheduling regular maintenance.

PTO (Power Take Off)

The PTO (power take off) light will be on when the key is in the run or lights positions and the PTO (power take off) is engaged on. When this light is on it is a reminder; the starter will not crank and turn off the PTO before getting off.

Driving Forward or Backward

The throttle control regulates the engine speed as measured in rpm (revolutions per minute). Place the throttle control in the fast position for best performance.

To go forward or backward, release the parking brake: refer to Releasing the Parking Brake, page 15. Place your foot on the traction control pedal and slowly press on the top of the traction control pedal to move forward or on the bottom of the traction control pedal to move backward (Fig. 10). The farther you move the traction control pedal in either direction, the faster the machine will move in that direction.

Note: For reverse motion, with the PTO engaged, the operating-in-reverse interlock must be deactivated by the KeyChoice switch located on the seat bracket on the right hand side just below the seat.

To slow down, release the pressure on the traction control pedal.

Important To avoid transmission damage, always release the parking brake before moving the traction control pedal.

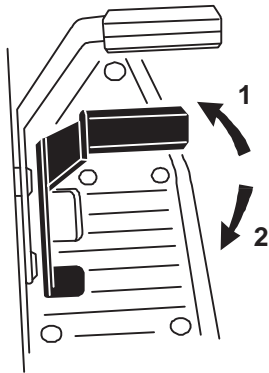

Figure 10

1. Forward

2. Backward

Stopping the Machine

To stop the machine, release the traction control pedal, disengage the power take off (PTO), and turn the ignition key to stop the engine. Also set the parking brake if you

leave the machine unattended; refer to Setting the Parking Brake, page 15. Remember to remove the ignition and KeyChoice keys from the switches.

! **Caution** !

Children or bystanders may be injured if they move or attempt to operate the tractor while it is unattended.

Always remove the ignition and KeyChoice keys and set the parking brake when leaving the machine unattended, even if just for a few minutes.

Using the Attachment Lift Lever

The attachment lift lever (Fig. 11) is used to raise and lower various attachments.

Raising Attachments

1. Depress the brake pedal to stop the machine.
2. Pull attachment lift lever rearward until latch locks. In this position the lift will hold the attachment in the up, or raised position.

Lowering Attachments

1. Depress the brake pedal to stop the machine.
2. Pull attachment lift lever rearward, to release lift pressure, and push the button on top to release the latch. Move lift lever forward to lower attachment.

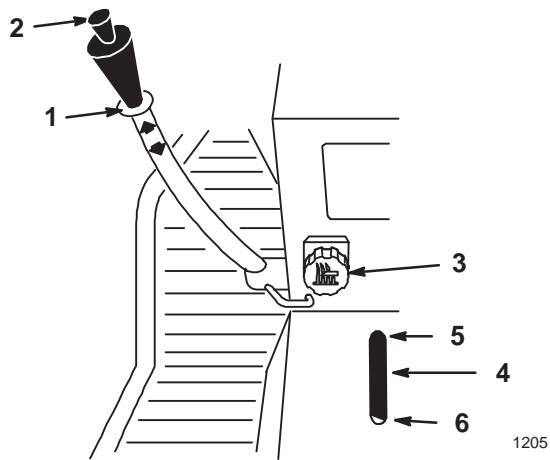

Figure 11

- | | |
|------------------|----------------------|
| 1. Lift lever | 4. Indicator |
| 2. Button | 5. High |
| 3. Dial-A-Height | 6. Mounting position |

1205

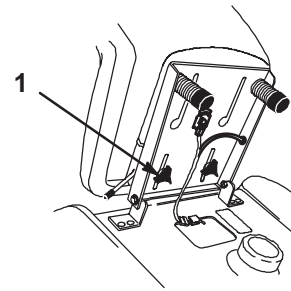

Figure 12

1. Adjustment knob

m-4982

Adjusting the Dial-A-Height

The Dial-A-Height control (Fig. 11) is used to limit the downward travel of the attachment. The Dial-A-Height knob is rotated to change the location of this stop, up or down.

1. Raise the attachment lift lever: Refer to Raising Attachments. In the raised position the Dial-A-Height knob (Fig. 11) can be rotated to change the stop location. Turn clockwise to raise and counterclockwise to lower the height of the attachment.
2. The Dial-A-Height indicator (Fig. 11) will show the change, high to low, in attachment lift height as adjustment is made.

Positioning the Seat

The seat can move forward and backward. Position the seat where you have the best control of the machine and are most comfortable.

1. Raise the seat and loosen the adjustment knobs (Fig. 12).
2. Slide the seat to the desired position and tighten the knobs.

Using the Headlights

The headlights are turned on with a separate position, lights, of the ignition switch (Fig. 13). The lights are on while the ignition switch is in the lights position even with the engine off. Remove the key when the machine is left unattended so lights can not be turned on discharging the battery.

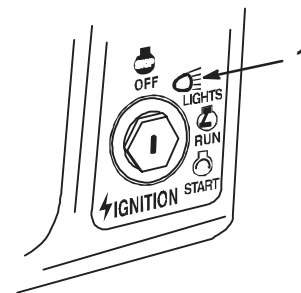

Figure 13

1. Lights

1208

Positioning the Tilt Steering Wheel

The steering wheel has four tilt locations. Position the steering wheel where you have the best control of the machine and are most comfortable.

1. Lift the tilt lever to release the lock (Fig. 14).
2. Move the steering wheel to a comfortable position; then release the lever to lock.

Maintenance

Recommended Maintenance Schedule

Maintenance Service Interval	Maintenance Procedure
After First Use	<ul style="list-style-type: none"> • Change oil¹
Each Use	<ul style="list-style-type: none"> • Check oil level • Check safety system • Check brake • Clean outside of engine
Every 5 Hours	<ul style="list-style-type: none"> • Check battery electrolyte
Every 25 Hours	<ul style="list-style-type: none"> • Service foam air cleaner¹ • Check spark plug(s) • Check tire pressure • Check front wheel toe-in
Every 50 Hours	<ul style="list-style-type: none"> • Grease chassis¹ • Check belts for wear/cracks
Every 100 Hours	<ul style="list-style-type: none"> • Change oil¹ • Replace paper air cleaner¹ • Replace fuel filter
Every 200 Hours	<ul style="list-style-type: none"> • Change oil filter¹
Before Storage	<ul style="list-style-type: none"> • Change oil filter • Check brake • Grease chassis • Service foam air cleaner • Replace paper air cleaner • Check spark plug(s) • Check belts for wear/cracks • Drain gasoline • Clean outside of engine • Paint chipped surfaces • Check battery electrolyte • Charge battery and disconnect cables • Replace fuel filter • Check tire pressure • Check front wheel toe-in
After Storage	<ul style="list-style-type: none"> • Check safety system • Check brake • Check spark plug(s) • Check battery electrolyte • Check tire pressure

¹More often in dusty, dirty conditions

Important Refer to your engine operator's manual for additional maintenance procedures.



Caution



If you leave the key in the ignition switch, someone could accidentally start the engine and seriously injure you or other bystanders.

Remove the key from the ignition and disconnect the wire from the spark plug before you do any maintenance. Set the wire aside so that it does not accidentally contact the spark plug.

Servicing the Air Cleaner

Service Interval/Specification

Foam Element: Clean and re-oil after every 25 operating hours, or yearly, whichever occurs first.

Paper Element: Replace after every 100 operating hours or yearly, whichever occurs first.

Note: Service the air cleaner more frequently (every few hours) if operating conditions are extremely dusty or sandy.

Removing the Foam and Paper Elements

1. Disengage the power take off (PTO), set the parking brake, and turn the ignition key to off. Remove the ignition key.
2. Open the hood.
3. Clean around the air cleaner to prevent dirt from getting into the engine and causing damage. Remove knob and the air cleaner cover (Fig. 17).

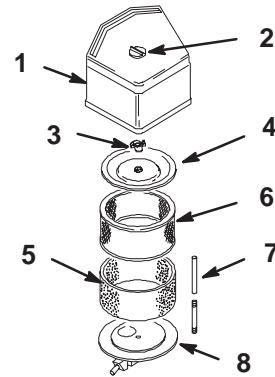

Figure 17

- | | |
|----------------------|---------------------|
| 1. Air cleaner cover | 5. Foam element |
| 2. Knob | 6. Paper element |
| 3. Cover nut | 7. Rubber seal |
| 4. Cover | 8. Air cleaner base |

1214

4. Carefully slide the foam element off the paper element (Fig. 17).
5. Unscrew the cover nut and remove the cover and paper element (Fig. 17).

Cleaning the Foam Element

1. Wash the foam element in liquid soap and warm water. When the element is clean, rinse it thoroughly.
2. Dry the element by squeezing it in a clean cloth.
3. Put one or two ounces of oil on the element (Fig. 18). Squeeze the element to distribute the oil.

Important Replace the foam element if it is torn or worn.

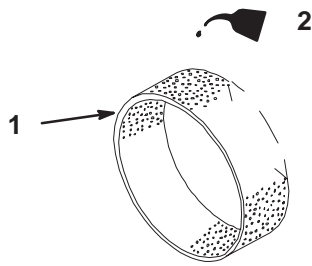

Figure 18

1213

1. Foam element 2. Oil

Cleaning the Paper Element

1. Lightly tap the element on a flat surface to remove dust and dirt (Fig. 19).
2. Inspect the element for tears, an oily film, and damage to the rubber seal.

Important Never clean the paper element with pressurized air or liquids, such as solvent, gas, or kerosene. Replace the paper element if it is damaged or cannot be cleaned thoroughly.

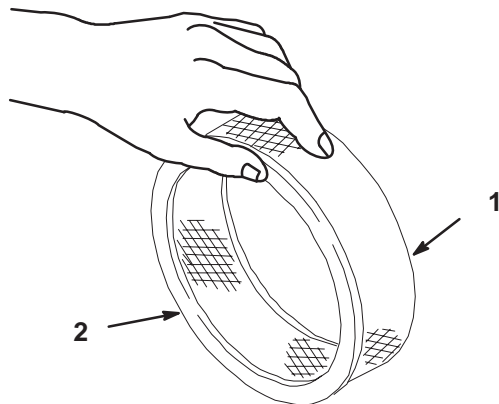

Figure 19

1213

1. Paper element 2. Rubber seal

Installing the Foam and Paper Elements

Important To prevent engine damage, always operate the engine with the complete foam and paper air cleaner assembly installed.

1. Carefully slide the foam element onto the paper air cleaner element (Fig. 17).
2. Slide the air cleaner assembly and cover onto the long rod. Now screw the cover nut finger-tight against the cover (Fig. 17).

Note: Make sure the rubber seal is flat against the air cleaner base and cover.

3. Install the air cleaner cover (Fig. 17).
4. Close the hood.

Servicing the Engine Oil

Service Interval/Specification

Change oil:

- After the first 5 operating hours.
- After every 100 operating hours.

Note: Change oil more frequently when operating conditions are extremely dusty or sandy.

Oil Type: Detergent oil (API service SF or SG)

Crankcase Capacity: w/filter, 4 pints (1.9 l)

Viscosity: See table below

USE THESE SAE VISCOSITY OILS

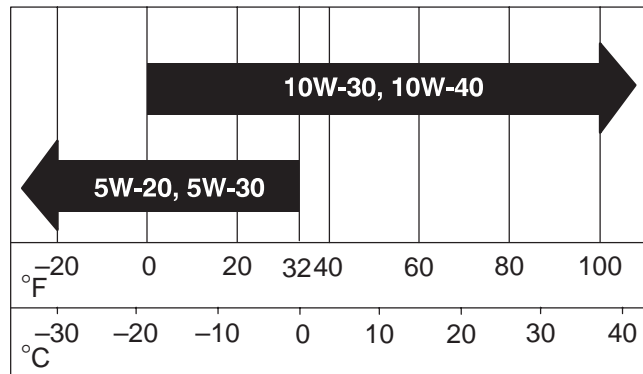

Checking the Oil Level

1. Park the machine on a level surface, disengage the power take off (PTO), set the parking brake, and turn the ignition key to off. Remove the ignition key.
2. Open the hood.
3. Clean around the oil dipstick (Fig. 20) so dirt cannot fall into the filler hole and damage the engine.
4. Unscrew the oil dipstick and wipe the metal end clean (Fig. 20).
5. Slide the oil dipstick fully into the filler tube, do not thread onto tube (Fig. 20). Pull the dipstick out and look at the metal end. If oil level is low, slowly pour only enough oil into the filler tube to raise the level to the full mark.

Important Do not overfill the crankcase with oil because the engine may be damaged.

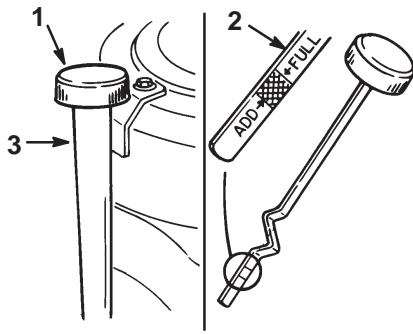

Figure 20

- 1. Oil dipstick
- 2. Metal end
- 3. Filler tube

Changing the Oil

1. Start the engine and let it run five minutes. This warms the oil so it drains better.
2. Park the machine so that the drain side is slightly lower than the opposite side to assure the oil drains completely. Then disengage the power take off (PTO), set the parking brake, and turn the ignition key to off. Remove the ignition key.
3. Open the hood.
4. Slide a piece of hose over oil drain to direct oil.
5. Place a pan below the oil drain. Open the drain by turning counterclockwise, 1/8 turn and pull out (Fig. 21).
6. When oil has drained completely, close the drain by pushing in and turning clockwise, 1/8 turn.

Note: Dispose of the used oil at a certified recycling center.

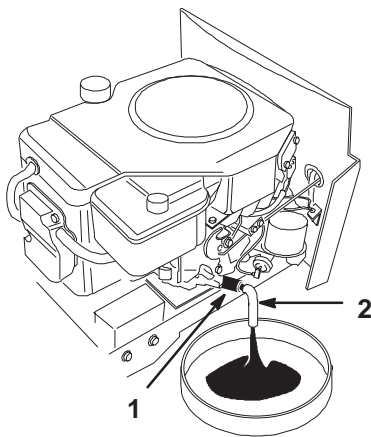

Figure 21

- 1. Oil drain
- 2. Hose

7. Slowly pour approximately 80% of the specified amount of oil into the filler tube (Fig. 20). Now check the oil level; refer to Checking Oil Level, page 24. Slowly add additional oil to bring to full mark on dipstick.

Changing the Oil Filter

Replace the oil filter every 200 hours or every other oil change.

Note: Change oil filter more frequently when operating conditions are extremely dusty or sandy.

1. Drain the oil from the engine; refer to Changing/Draining Oil, page 25.
2. Remove the old filter and wipe the filter adapter (Fig. 22) gasket surface.
3. Apply a thin coat of new oil to the rubber gasket on the replacement filter (Fig. 22).

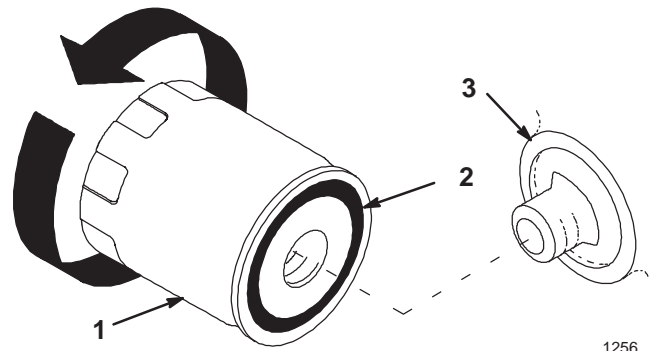

Figure 22

- 1. Oil filter
- 2. Gasket
- 3. Adapter

4. Install the replacement oil filter to the filter adapter. Turn the oil filter clockwise until the rubber gasket contacts the filter adapter, then tighten the filter an additional 1/2 turn (Fig. 22).
5. Fill the crankcase with the proper type of new oil; refer to Changing/Draining Oil, page 25.

Servicing the Spark Plug

Service Interval/Specification

Check the spark plug(s) after every 200 operating hours. Make sure the air gap between the center and side electrodes is correct before installing the spark plug. Use a spark plug wrench for removing and installing the spark plug(s) and a gapping tool/feeler gauge to check and adjust the air gap.

Type: Champion RC-12YC (or equivalent)

Air Gap: 0.040 in. (1.02 mm)

Removing the Spark Plug(s)

1. Disengage the power take off (PTO), set the parking brake, and turn the ignition key to off. Remove the ignition key.
2. Open the hood.
3. Pull the wire(s) off the spark plug(s) (Fig. 23). Now clean around the spark plug(s) to prevent dirt from falling into the engine and potentially causing damage.
4. Remove the spark plug(s).

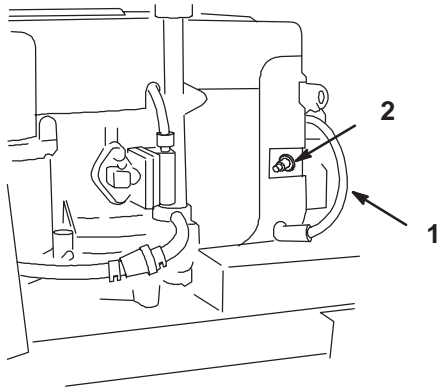

Figure 23

1. Spark plug wire
2. Spark plug

Checking the Spark Plug

1. Look at the center of the spark plug(s) (Fig. 24). If you see light brown or gray on the insulator, the engine is operating properly. A black coating on the insulator usually means the air cleaner is dirty.

Important Never clean the spark plug(s). Always replace the spark plug(s) when it has: a black coating, worn electrodes, an oily film, or cracks.

2. Check the gap between the center and side electrodes (Fig. 24). Bend the side electrode (Fig. 24) if the gap is not correct.

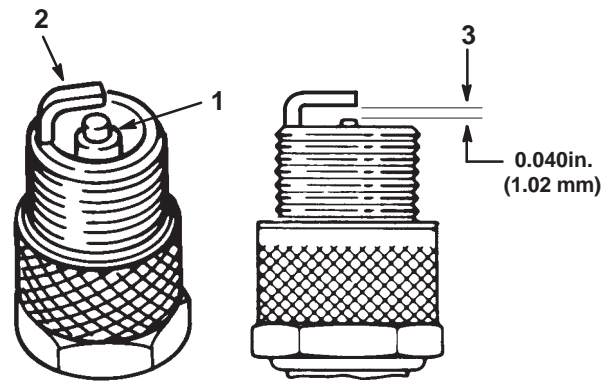

Figure 24

1. Center electrode insulator
2. Side electrode
3. Air gap (not to scale)

Installing the Spark Plug(s)

1. Install the spark plug(s). Make sure the air gap is set correctly.
2. Tighten the spark plug(s) to 20 ft-lb (27 Nm).
3. Push the wire(s) onto the spark plug(s) (Fig. 23).
4. Close the hood.

Greasing and Lubrication

Service Interval/Specification

Grease the machine after every 50 operating hours or yearly, whichever occurs first. Grease more frequently when operating conditions are extremely dusty or sandy.

Grease Type: General-purpose grease.

How to Grease

1. Disengage the power take off (PTO), set the parking brake, and turn the ignition key to off. Remove the ignition key.
2. Clean the grease fittings with a rag. Make sure to scrape any paint off the front of the fitting(s).
3. Connect a grease gun to the fitting. Pump grease into the fittings until grease begins to ooze out of the bearings.
4. Wipe up any excess grease.

Where to Add Grease

1. Lubricate the front wheels and spindles until grease begins to ooze out of the bearings (Fig. 25).
2. Lubricate the front axle pivot (Fig. 25).

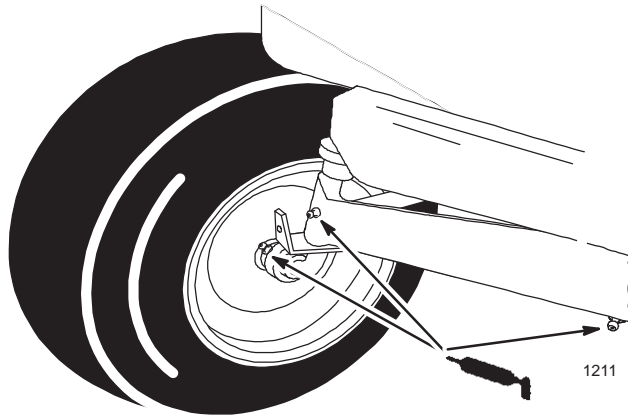

Figure 25

3. Lubricate the traction control pedal on hydrostatic models (or brake and clutch pedals on gear drive models) where they pivot on mounting shaft (Fig. 26).

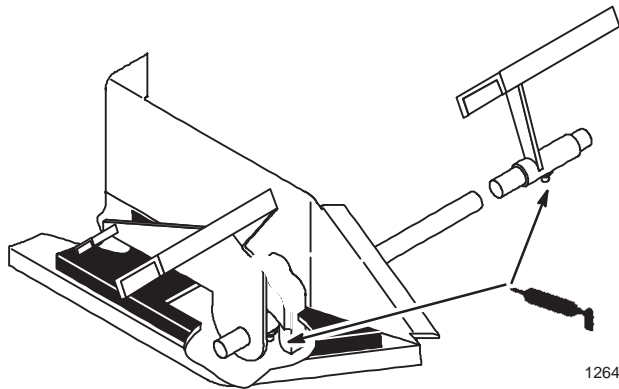

Figure 26

Checking the Tire Pressure

Service Interval/Specification

Maintain the air pressure in the front and rear tires as specified. Check the pressure at the valve stem after every 25 operating hours or monthly, whichever occurs first (Fig. 27). Check the tires when they are cold to get the most accurate pressure reading.

Pressure: 20 psi (138 kPa) front and rear

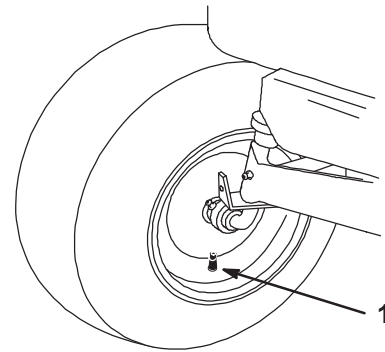

Figure 27

1. Valve stem

2323

Servicing the Brake

Always set the parking brake when you stop the machine or leave it unattended. If the parking brake does not hold securely, an adjustment is required.

Checking the Brake

1. Park the machine on a level surface, disengage the power take off (PTO), set the parking brake, and turn the ignition key to off. Remove the ignition key.
2. Rear wheels must lock and skid when you try to push the tractor forward. Adjustment is required if the wheels turn and do not lock; refer to Adjusting the Brake, page 27.
3. Release the brake and move the drive control rod to the push position; refer to Pushing the Machine by Hand, page 21. Wheels should rotate freely.
4. If both conditions are met no adjustment is required.

Adjusting the Brake

1. Check the brake before you adjust it; refer to Checking the Brake, page 27.
2. Release the parking brake; refer to Releasing the Parking Brake, page 15.
3. To adjust the brake remove the cotter pin and loosen the brake adjusting nut slightly (Fig. 28).
4. Carefully insert a 0.015 in. (.38 mm) feeler gauge between the outer brake pad and rotor disk (Fig. 28).
5. Tighten the brake adjusting nut until slight resistance is felt on the feeler gauge when sliding it in and out. Install cotter pin.
6. Check the brake operation again; refer to Checking the Brake, page 27.

Important With the parking brake released, the rear wheels must rotate freely when you push the mower. If the 0.015 in. (.38 mm) clearance and free wheel rotation cannot be achieved contact your service dealer immediately.

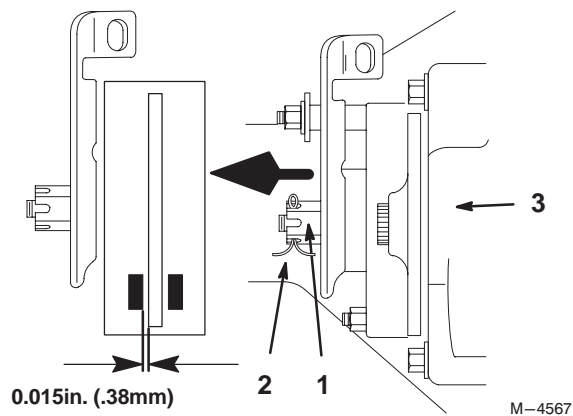

Figure 28

1. Brake adjusting nut
2. Cotter pin
3. Right Front of Transaxle

Servicing the Fuel Tank

Draining The Fuel Tank

Danger

In certain conditions, gasoline is extremely flammable and highly explosive. A fire or explosion from gasoline can burn you and others and can damage property.

- Drain gasoline from the fuel tank when the engine is cold. Do this outdoors in an open area. Wipe up any gasoline that spills.
- Never smoke when draining gasoline, and stay away from an open flame or where a spark may ignite the gasoline fumes.

1. Park the machine on a level surface, to assure fuel tank drains completely. Then disengage the power take off (PTO), set the parking brake, and turn the ignition key to off. Remove the ignition key.
2. Close fuel shut-off valve at fuel tank (Fig. 29).

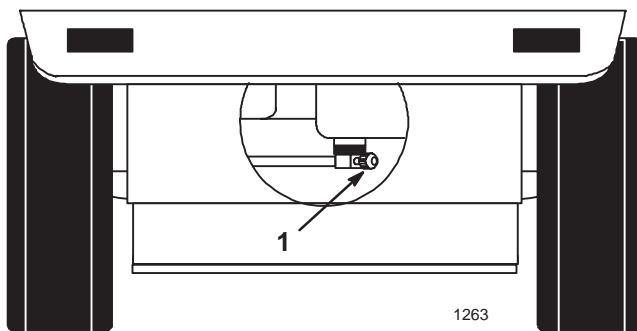

Figure 29

1. Fuel shut-off valve
 3. Open the hood.
 4. Squeeze the ends of the hose clamp together and slide it up the fuel line toward the fuel tank (Fig. 30).
 5. Pull the fuel line off the filter (Fig. 30). Open fuel shut-off valve and allow gasoline to drain into an approved gas can.
- Note:** Now is the best time to install a new fuel filter because the fuel tank is empty.
6. Install the fuel line onto the filter. Slide the hose clamp close to the filter to secure the fuel line and filter. Refer to Replacing the Fuel Filter; page 29.

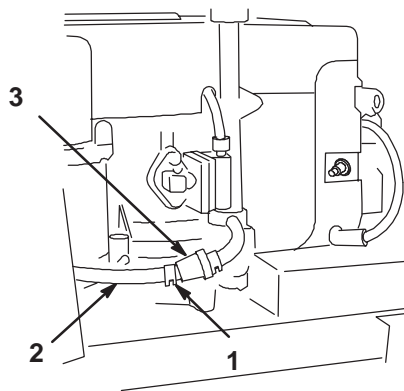

Figure 30

1. Hose clamp
2. Fuel line
3. Filter

Servicing the Fuel Filter

Service Interval/Specification

Replace the fuel filter after every 100 operating hours or yearly, whichever occurs first.

Replacing the Fuel Filter

Never install a dirty filter if it is removed from the fuel line.

1. Disengage the power take off (PTO), set the parking brake, and turn the ignition key to off. Remove the ignition key.
2. Close fuel shut-off valve at fuel tank (Fig. 29).
3. Open the hood.
4. Squeeze the ends of the hose clamps together and slide them away from the filter (Fig. 31).
5. Remove the filter from the fuel lines.

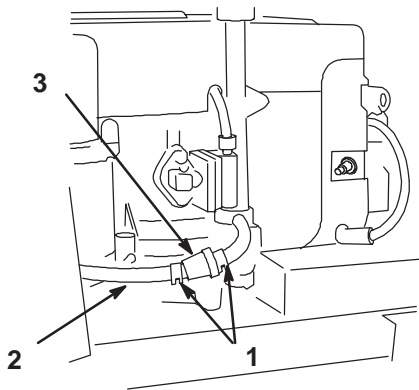

Figure 31

1. Hose clamp
2. Fuel line
3. Filter

1217

6. Install a new filter and move the hose clamps close to the filter.
7. Open fuel shut-off valve at fuel tank (Fig. 29).
8. Close the hood.

Adjusting the Front Wheel Toe-In

Service Interval/Specification

Maintain toe-in of the front wheels as specified. If uneven tire wear, lawn scuffing or hard steering develop adjustment may be required. Check the toe-in after every 100 operating hours or yearly, whichever occurs first (Fig. 32).

Specification: 1/8–1/4 inch toe-in on front wheels.

Measuring the Toe-in

1. Disengage the power take off (PTO), set the parking brake, and turn the ignition key to off. Remove the ignition key.

2. Push front tires out, at front, to remove normal looseness in the linkage.
3. Measure, between the rims, at spindle level, in the front and rear of the wheels (Fig. 32).
4. The front measurement should be less than the rear, as specified.

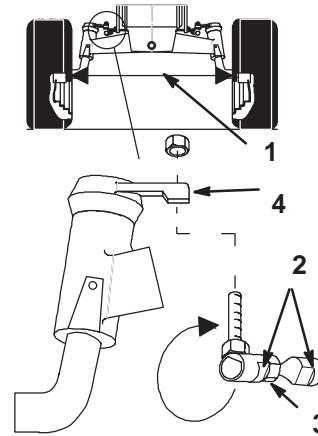

m-1261

Figure 32

1. Measure here
2. Flats
3. Jam nut
4. Steering lever

Adjusting the Toe-In

1. Check the toe-in before you adjust it; refer to Measuring Toe-In, Page 29.
2. Remove ball joint from one steering lever (Fig. 32).
3. Loosen jam nut securing ball joint to steering rod. Rotate ball joint one turn, clockwise to increase or counter clockwise to decrease toe-in.
4. Hold flats on ball joint to align with flats on tie rod and tighten jam nut (Fig. 32).
5. Install ball joint to steering lever and check the toe-in; refer to Measuring Toe-In, Page 32.

Important If more than one turn is required to meet specifications, alternate between left and right steering rods to maintain steering wheel alignment.

Servicing the Transaxle Fluid

Service Interval/Specification

The transaxle is a sealed system and no checking or changing of the fluid is required.

Important If any transaxle problems arise, contact your local Authorized Service Dealer for help and service.

Servicing the Fuse

Service Interval/Specification

The electrical system is protected by fuses. It requires no maintenance, however, if a fuse blows check component/circuit for malfunction or short. To replace fuses pull up on the fuse (Fig. 33) to remove or replace it.

- Fuse: Main/Starter F1—30 amp, blade-type
Alternator F2—25 amp, blade-type
Dash/Hour meter F3—10 amp, blade-type
Head lights F4—10 amp, blade-type

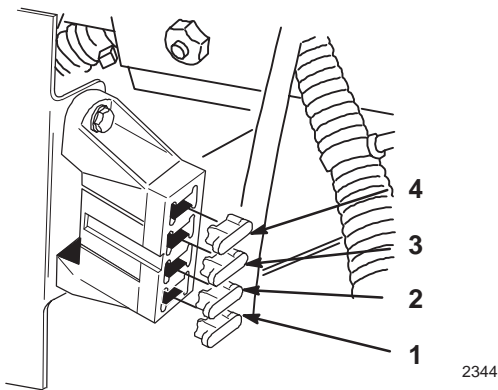

Figure 33

- | | |
|----------------------|---------------------------|
| 1. Main—30 amp | 3. Dash/Hour meter—10 Amp |
| 2. Alternator—25 amp | 4. Head lights—10 amp |

Servicing the Headlights

Specification: Bulb No. 1156 Automotive Type

Removing the Bulb

1. Disengage the power take off (PTO), set the parking brake, and turn the ignition key to off. Remove the ignition key.
2. Open the hood. Pull wire connectors off both bulb holder terminals.

3. Rotate the bulb holder 1/4 turn counterclockwise and remove it from the reflector (Fig. 34).
4. Push and rotate the bulb counterclockwise until it stops (approx. 1/4 turn) and remove bulb from the bulb holder (Fig. 35).

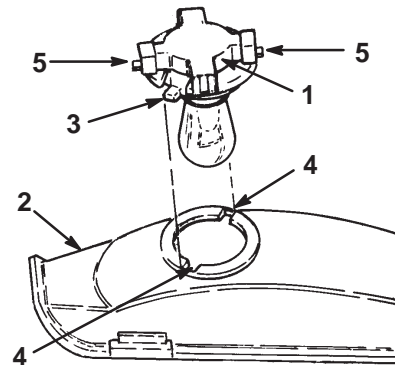

Figure 34

- | | |
|----------------|--------------|
| 1. Bulb holder | 4. Slots |
| 2. Reflector | 5. Terminals |
| 3. Tabs | |

Installing the Bulb

1. The bulb has metal pins on the side of its base. Align the pins with the slots in the bulb holder and insert the base into the holder (Fig. 35). Push and rotate the bulb clockwise until it stops.

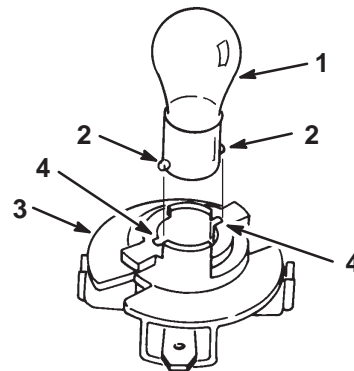

Figure 35

- | | |
|---------------|----------------|
| 1. Bulb | 3. Bulb holder |
| 2. Metal pins | 4. Slots |

2. The bulb holder has two tabs (Fig. 34). Align the tabs with the slots in the reflector, insert the bulb holder into the reflector and rotate it 1/4 turn clockwise until it stops.

3. Push the wire connectors onto the terminals on the bulb holder.

Servicing the Battery



Warning



Battery posts, terminals, and related accessories contain lead and lead compounds, chemicals known to the State of California to cause cancer and reproductive harm. *Wash hands after handling.*

Service Interval/Specification

Always keep the battery clean and fully charged. Use a paper towel to clean the battery case. If the battery terminals are corroded, clean them with a solution of four parts water and one part baking soda. Apply a light coating of grease to the battery terminals to prevent corrosion.

Voltage: 12 v, 260 Cold Cranking Amps

Removing the Battery



Warning



Battery terminals or metal tools could short against metal tractor components causing sparks. Sparks can cause the battery gasses to explode, resulting in personal injury.

- When removing or installing the battery, do not allow the battery terminals to touch any metal parts of the tractor.
- Do not allow metal tools to short between the battery terminals and metal parts of the tractor.



Warning



Incorrect battery cable routing could damage the tractor and cables causing sparks. Sparks can cause the battery gasses to explode, resulting in personal injury.

- Always **DISCONNECT** the negative (black) battery cable before disconnecting the positive (red) cable.
- Always **RECONNECT** the positive (red) battery cable before reconnecting the negative (black) cable .

1. Disengage the power take off (PTO), set the parking brake, and turn the ignition key to off. Remove the key.
2. Open the hood and locate the battery.
3. Remove side panels for clearance when removing battery (Fig. 37). Remove screws and lift up to clear pin and slide panel tabs out from steering tower.
4. Disconnect the negative (black) ground cable from the battery post (Fig. 36).
5. Lift the red rubber cover up on the positive cable. Disconnect the positive cable (red cover) from the battery post (Fig. 36).
6. Remove the battery hold down strap (Fig. 36). Remove battery from the tractor.

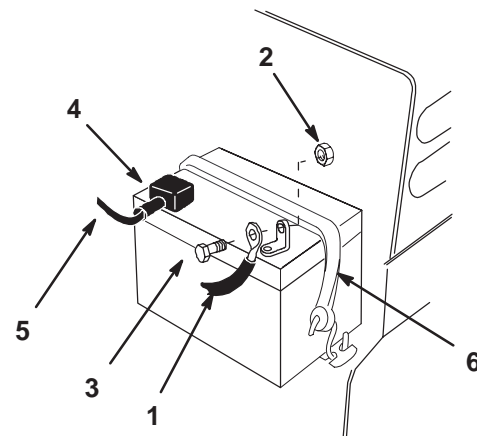

m-4972

Figure 36

- | | |
|-------------------|----------------------------|
| 1. Negative cable | 4. Rubber cover (red) |
| 2. Nut | 5. Positive cable |
| 3. Bolt | 6. Battery Hold Down Strap |

Installing the Battery

1. Install the battery into the tractor (Fig. 37).
2. Secure battery with hold down strap (Fig. 36).
3. Using the bolt and nut, connect the positive (red cover) cable to the positive (+) battery post (Fig. 36). Slide the rubber cover over the battery post.
4. Using the bolt and nut, connect the negative (black) cable to the negative (-) battery post (Fig. 36).
5. Install side panels by sliding tabs into steering tower and inserting pin into flange of footrest. Secure with screws (Fig. 37).

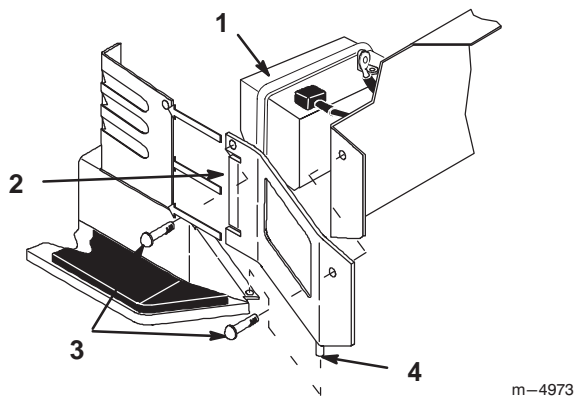
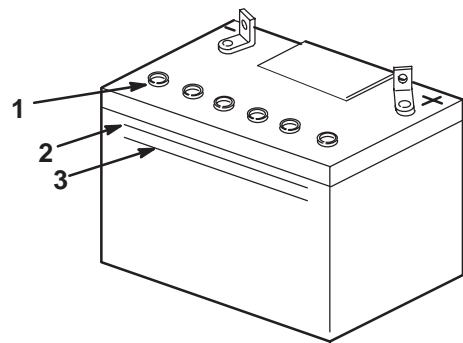

Figure 37

- | | |
|--------------------|----------|
| 1. Battery | 3. Screw |
| 2. Side panel tabs | 4. Pin |



m-5004

Figure 38

- | | |
|----------------|---------------|
| 1. Filler caps | 3. Lower line |
| 2. Upper line | |

! **Danger** !

Battery electrolyte contains sulfuric acid which is a deadly poison and causes severe burns.

- **Do not drink electrolyte and avoid contact with skin, eyes or clothing. Wear safety glasses to shield your eyes and rubber gloves to protect your hands.**
- **Fill the battery where clean water is always available for flushing the skin.**
- **Follow all instructions and comply with all safety messages on the electrolyte container.**

Checking Electrolyte Level

1. With the engine off, open the hood to locate the battery.
2. Look at the side of the battery. The electrolyte must be up to the upper line (Fig. 38). Do not allow the electrolyte to get below the lower line (Fig. 38).
3. If the electrolyte is low, add the required amount of distilled water; refer to Adding Water to the Battery, page 32.

Adding Water to the Battery

The best time to add distilled water to the battery is just before you operate the machine. This lets the water mix thoroughly with the electrolyte solution.

1. Remove the battery from the tractor.
2. Clean the top of the battery with a paper towel.

Note: Never fill the battery with distilled water while the battery installed in the tractor. Electrolyte could be spilled on other parts and cause corrosion.

3. Remove the vent caps from the battery (Fig. 38).
4. Slowly pour distilled water into each battery cell until the level is up to the upper line (Fig. 38) on the battery case.

Important Do not overfill the battery because electrolyte (sulfuric acid) can cause severe corrosion and damage to the chassis.

5. Wait five to ten minutes after filling the battery cells. Add distilled water, if necessary, until the electrolyte level is up to the upper line (Fig. 38) on the battery case.

6. Reinstall battery vent caps.

Charging the Battery

! **Warning** !

Charging the battery produces gasses that can explode.

Never smoke near the battery and keep sparks and flames away from battery.

Important Always keep the battery fully charged (1.265 specific gravity). This is especially important to prevent battery damage when the temperature is below 32°F (0°C).

1. Remove the battery from the chassis; refer to Removing the Battery, page 31.
2. Check the electrolyte level; refer to Checking Electrolyte Level, page 32.
3. Make sure the filler caps are installed in battery. Charge battery for 10 to 15 minutes at 25 to 30 amps or 30 minutes at 4–6 amps.
4. When the battery is fully charged, unplug the charger from the electrical outlet, then disconnect the charger leads from the battery posts (Fig. 39).

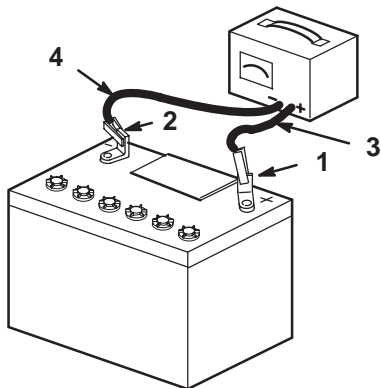

m-4970

Figure 39

- | | |
|--------------------------|---------------------------|
| 1. Positive Battery Post | 3. Red (+) Charger Lead |
| 2. Negative Battery Post | 4. Black (-) Charger Lead |

5. Install the battery in the tractor and connect the battery cables; refer to Installing the Battery on page 32.

Note: Do not run the tractor with the battery disconnected. Electrical damage may occur.

Wiring Diagram

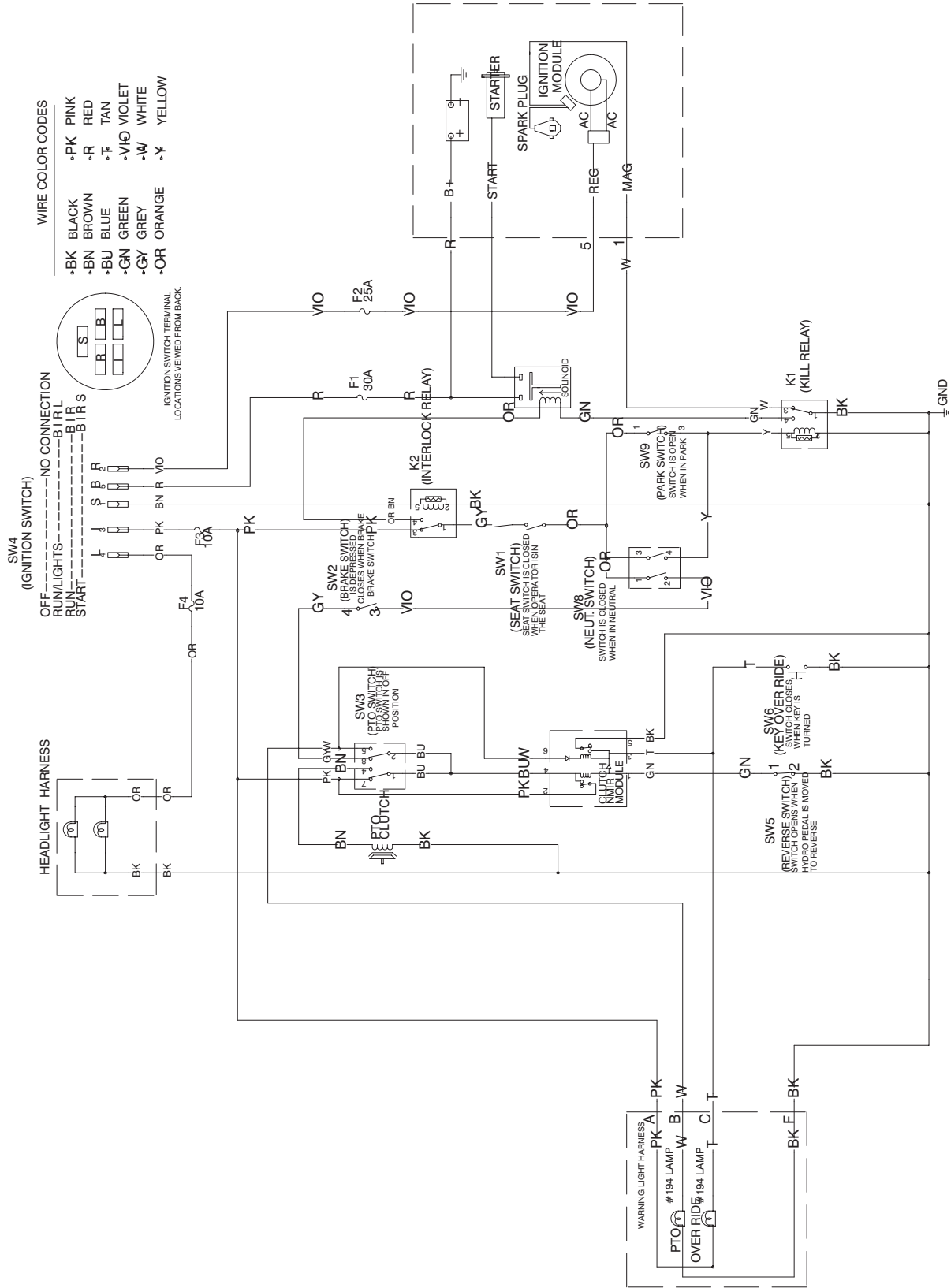

Cleaning and Storage

1. Disengage the power take off (PTO), set the parking brake, and turn the ignition key to off. Remove the ignition and KeyChoice keys.
2. Remove grass clippings, dirt, and grime from the external parts of the entire machine, especially the engine. Clean dirt and chaff from the outside of the engine's cylinder head fins and blower housing.

Important You can wash the machine with mild detergent and water. Do not pressure wash the machine. Avoid excessive use of water, especially near the control panel, lights, engine, and the battery.

3. Check the brake; refer to Servicing the Brake, page 27.
4. Service the air cleaner; refer to Servicing the Air Cleaner, page 23.
5. Grease the chassis; refer to Greasing and Lubrication, page 26.
6. Change the crankcase oil and filter; refer to Servicing the Engine Oil, page 24.
7. Check the tire pressure; refer to Checking the Tire Pressure, page 27.
8. Prepare the machine for storage when non-use occurs over 30 days. Prepare machine for storage as follows.
 - A. Add a petroleum based stabilizer/ conditioner to fuel in the tank. Follow mixing instructions from stabilizer manufacture. **Do not use an alcohol based stabilizer (ethanol or methanol).**

Note: A fuel stabilizer/conditioner is most effective when mixed with fresh gasoline and used at all times.

- B. Run engine to distribute conditioned fuel through the fuel system (5 minutes).
- C. Stop engine, allow to cool and drain the fuel tank; refer to Servicing the Fuel Tank, page 28.

- D. Restart engine and run it until it stops.
- E. Choke or prime the engine. Start and run engine until it will not start. Operate primer, if equipped on machine, several times to ensure fuel remains in primer system.
- F. Dispose of fuel properly. Recycle as per local codes.

Important Do not store stabilizer/conditioned gasoline over 90 days.

Important The battery must be fully charged to prevent it from freezing and being damaged at temperatures below 32°F (0°C). A fully charged battery can be stored one winter season without recharging.

9. Remove the spark plug(s) and check its condition; refer to Servicing the Spark Plug, page 25. With the spark plug(s) removed from the engine, pour two tablespoons of engine oil into the spark plug hole. Now use the electric starter to crank the engine and distribute the oil inside the cylinder. Install the spark plug(s) and tighten it to 30 ft-lb (40 Nm). Do not install the wire on the spark plug(s).
10. Disconnect the negative battery cable. Clean the battery and battery terminals. Check the electrolyte level and charge it fully; refer to Servicing the Battery on page 31. Leave the negative battery cable disconnected from the battery during storage.
11. Check and tighten all bolts, nuts, and screws. Repair or replace any part that is damaged or defective.
12. Paint all scratched or bare metal surfaces. Paint is available from your Authorized Service Dealer.
13. Store the machine in a clean, dry garage or storage area. Remove the keys from the ignition and KeyChoice switches and keep it in a memorable place. Cover the machine to protect it and keep it clean.

Troubleshooting

Problem	Possible Causes	Corrective Action
Starter does not crank	<ol style="list-style-type: none"> 1. Blade control (PTO) is ENGAGED. 2. Parking brake is not on. 3. Operator is not seated. 4. Battery is dead. 5. Electrical connections are corroded or loose. 6. Fuse is blown. 7. Relay or switch is defective. 	<ol style="list-style-type: none"> 1. Move blade control (PTO) to DISENGAGED. 2. Set parking brake. 3. Sit on the seat. 4. Charge the battery. 5. Check electrical connections for good contact. 6. Replace fuse. 7. Contact Authorized Service Dealer.
Engine will not start, starts hard, or fails to keep running.	<ol style="list-style-type: none"> 1. Fuel tank is empty. 2. Choke is not ON. 3. Air cleaner is dirty. 4. Spark plug wire is loose or disconnected. 5. Spark plug is pitted, fouled, or gap is incorrect. 6. Dirt in fuel filter. 7. Dirt, water, or stale fuel is in fuel system. 	<ol style="list-style-type: none"> 1. Fill fuel tank with gasoline. 2. Move choke lever to ON. 3. Clean or replace air cleaner element. 4. Install wire on spark plug. 5. Install new, correctly gapped spark plug. 6. Replace fuel filter. 7. Contact Authorized Service Dealer.
Engine loses power.	<ol style="list-style-type: none"> 1. Engine load is excessive. 2. Air cleaner is dirty. 3. Oil level in crankcase is low. 4. Cooling fins and air passages under engine blower housing are plugged. 5. Spark plug is pitted, fouled, or gap is incorrect. 6. Vent hole in fuel cap is plugged. 7. Dirt in fuel filter. 8. Dirt, water, or stale fuel is in fuel system. 	<ol style="list-style-type: none"> 1. Reduce ground speed. 2. Clean air cleaner element. 3. Add oil to crankcase. 4. Remove obstruction from cooling fins and air passages. 5. Install new, correctly gapped spark plug. 6. Clean or replace the fuel cap. 7. Replace fuel filter. 8. Contact Authorized Service Dealer.
Engine overheats.	<ol style="list-style-type: none"> 1. Engine load is excessive. 2. Oil level in crankcase is low. 3. Cooling fins and air passages under engine blower housing are plugged. 	<ol style="list-style-type: none"> 1. Reduce ground speed. 2. Add oil to crankcase. 3. Remove obstruction from cooling fins and air passages.

Problem	Possible Causes	Corrective Action
Abnormal vibration.	<ol style="list-style-type: none"> 1. Engine mounting bolts are loose. 2. Loose engine pulley, idler pulley, or blade pulley. 3. Engine pulley is damaged. 	<ol style="list-style-type: none"> 1. Tighten engine mounting bolts. 2. Tighten the appropriate pulley. 3. Contact Authorized Service Dealer.
Machine does not drive.	<ol style="list-style-type: none"> 1. Drive control is in push position. 2. Traction belt is worn, loose or broken. 3. Traction belt is off pulley. 	<ol style="list-style-type: none"> 1. Move drive control to operate position. 2. Contact Authorized Service Dealer. 3. Contact Authorized Service Dealer.





Consumer
Riding
Products

The Toro Total Coverage Guarantee

A Two-Year Full Warranty
(Limited Warranty for Commercial Use)

Conditions and Products Covered

The Toro Company and its affiliate, Toro Warranty Company, pursuant to an agreement between them, jointly promise to repair any Toro Product used for normal residential purposes* if defective in materials or workmanship. The following time periods apply from the date of purchase:

<u>Products</u>	<u>Warranty Period</u>
• All Products	2 year full warranty
• 300 and 5xi Series Tractors:	
Frame	5 year full warranty
Front Axle	5 year full warranty
Drive Shaft (5xi Series Only)	5 year full warranty
• All Batteries	1 year full warranty

This warranty covers both the cost of parts and labor, and transportation within a fifteen mile radius of the servicing dealer.

This warranty applies to all consumer riding products and their attachments.

* Normal residential purposes means use of the product on the same lot as your home. Use at more than one location is considered commercial use, and the commercial use warranty would apply.

Limited Warranty for Commercial Use

Toro Consumer Products and attachments used for commercial, institutional, or rental use are warranted against defects in materials or workmanship for the following time periods from the date of purchase:

<u>Products</u>	<u>Warranty Period</u>
• 300 and 5xi Series Tractors	
Liquid Cooled Gas Engines	1 year limited warranty
Air Cooled Gas and Diesel Engines	2 year limited warranty
All other items	1 year limited warranty
• All other Riding Products	90 day limited warranty

Instructions for Obtaining Warranty Service

If you think that your Toro Product contains a defect in materials or workmanship, follow this procedure:

1. Contact any Toro Authorized or Master Service Dealer to arrange service at their dealership. To locate a dealer convenient to you, refer to the Yellow Pages of your telephone directory (look under "Lawn Mowers") or access our website at www.Toro.com. U.S. Customers may also call 800-421-9684 to use our 24-hour Toro dealer locator system.
2. Bring the product and your proof of purchase (sales receipt) to the Service Dealer.

Countries Other than the United States or Canada

Customers who have purchased Toro products exported from the United States or Canada should contact their Toro Distributor (Dealer) to obtain guarantee policies for your country, province, or state. If for any reason you are dissatisfied with your Distributor's service or have difficulty obtaining guarantee information, contact the Toro importer. If all other remedies fail, you may contact us at Toro Warranty Company.

If for any reason you are dissatisfied with the Service Dealer's analysis or with the assistance provided, contact us at:

Customer Care Department, Consumer Division
Toro Warranty Company
8111 Lyndale Avenue South
Bloomington, MN 55420-1196
800-348-2424 (U.S. customers)
877-484-9255 (Canada customers)

Owner Responsibilities

You must maintain your Toro Product by following the maintenance procedures described in the operator's manual. Such routine maintenance, whether performed by a dealer or by you, is at your expense.

Items and Conditions Not Covered

There is no other express warranty except for special emission system coverage on some products. This express warranty does not cover:

- Cost of regular maintenance service or parts, such as filters, fuel, lubricants, tune-up parts, blade sharpening, brake and clutch adjustments.
- Any product or part which has been altered or misused or required replacement or repair due to normal wear, accidents, or lack of proper maintenance.
- Repairs necessary due to improper fuel, contaminants in the fuel system, or failure to properly prepare the fuel system prior to any period of non-use over three months.
- Pickup and delivery charges for distances beyond a fifteen mile radius from an Authorized Toro Service Dealer.

All repairs covered by this warranty must be performed by an Authorized Toro Service Dealer using Toro approved replacement parts.

General Conditions

Repair by an Authorized Toro Service Dealer is your sole remedy under this warranty.

Neither The Toro Company nor Toro Warranty Company is liable for indirect, incidental or consequential damages in connection with the use of the Toro Products covered by this warranty, including any cost or expense of providing substitute equipment or service during reasonable periods of malfunction or non-use pending completion of repairs under this warranty.

Some states do not allow exclusions of incidental or consequential damages, or limitations on how long an implied warranty lasts, so the above exclusions and limitations may not apply to you.

This warranty gives you specific legal rights, and you may also have other rights which vary from state to state.