



Greensmaster[®] 1000

Traction Unit

Model No. 04052 – 220000001 and up

Parts Catalog

Ordering Replacement Parts

To order replacement parts, please supply: the part number, the quantity, and the description of each part desired.

Understanding Reference Numbers

Each identified part in an illustration has a reference number. The reference number for a part also appears in the parts list, along with other information about the part.

This catalog uses two special reference number formats, one to indicate parts in a service assembly and another to indicate the quantity of a given part in an illustration.

Service Assembly Reference Numbers

Parts in service assemblies have reference numbers in the form **a:b**. The **a** represents the reference number of the entire service assembly and the **b** represents a sequential number unique to each part within the service assembly.

For example, a wheel assembly might be identified by reference number **6**, the tire by **6:1**, the valve by **6:2**, and the wheel by **6:3**. When you order the assembly identified by reference number **6**, you receive all parts identified by reference numbers **6:1**, **6:2**, and **6:3**. However, you may also order any part individually.

Reference numbers of this type appear in illustrations and in part lists.

Reference Numbers Indicating Quantity

In an illustration, if a reference number indicates more than one part, the reference number has the form **nX y**. The **n** represents the quantity of the part, the **X** is the multiplication symbol, and the **y** represents the reference number.

For example, in an illustration, the reference number **2X 37** means that two of the parts identified by reference number **37** are indicated.

Contents

Description	Page	Description	Page
Frame Assembly	3	Handle and Controls Assembly	15
Engine Mount and Frame Assembly	4	Roller and Scraper Options	16
Reel Drive Assembly	5	Roller and HOC Bar Assembly	17
Reel Assembly	7	Crankcase Assembly	18
Drum Drive Assembly	8	Camshaft and Valve Assembly	19
Drum and Basket Assembly	9	Ignition Assembly	20
Differential Assembly No. 93-6055	10	Governor Assembly	21
Inner Crankshaft Assembly	11	Carburetor Assembly	22
Outer Crankshaft Assembly	12	Air Cleaner and Muffler Assembly	23
Engine Assembly	13	Fuel Tank Assembly	24
Bellcrank Assembly	14	Decals	25

Part Description Abbreviations

Part descriptions in this catalog may include the following abbreviations.

Abbreviation	Meaning	Abbreviation	Meaning
AR	as required	HYD	hydraulic
ASM	assembly	INC	incorporated
CARR	carriage	LH	left hand
DEG	degrees	NI	nylon insert
FH	flat head	PPH	Phillips pan head
GA	gauge	PTH	Phillips truss head
HF	hex flange	PTO	power take off
HH	hex head	RH	right hand
HHF	hex head flange	SFH	slotted fillister head
HLH	hex lag head	SHH	slotted hex head
HJ	hex jam	SQH	square head
HOC	height-of-cut	SHWH	slotted hex washer head
HS	hex socket	SPH	slotted pan head
HSBH	hex socket button head	SRH	slotted round head
HSFH	hex socket flat head	STD	standard
HSH	hex socket head	TAP	self tapping
HWH	hex washer head	TTH	Torx truss head
HWHTF	hex washer head thread forming	WH	wing head

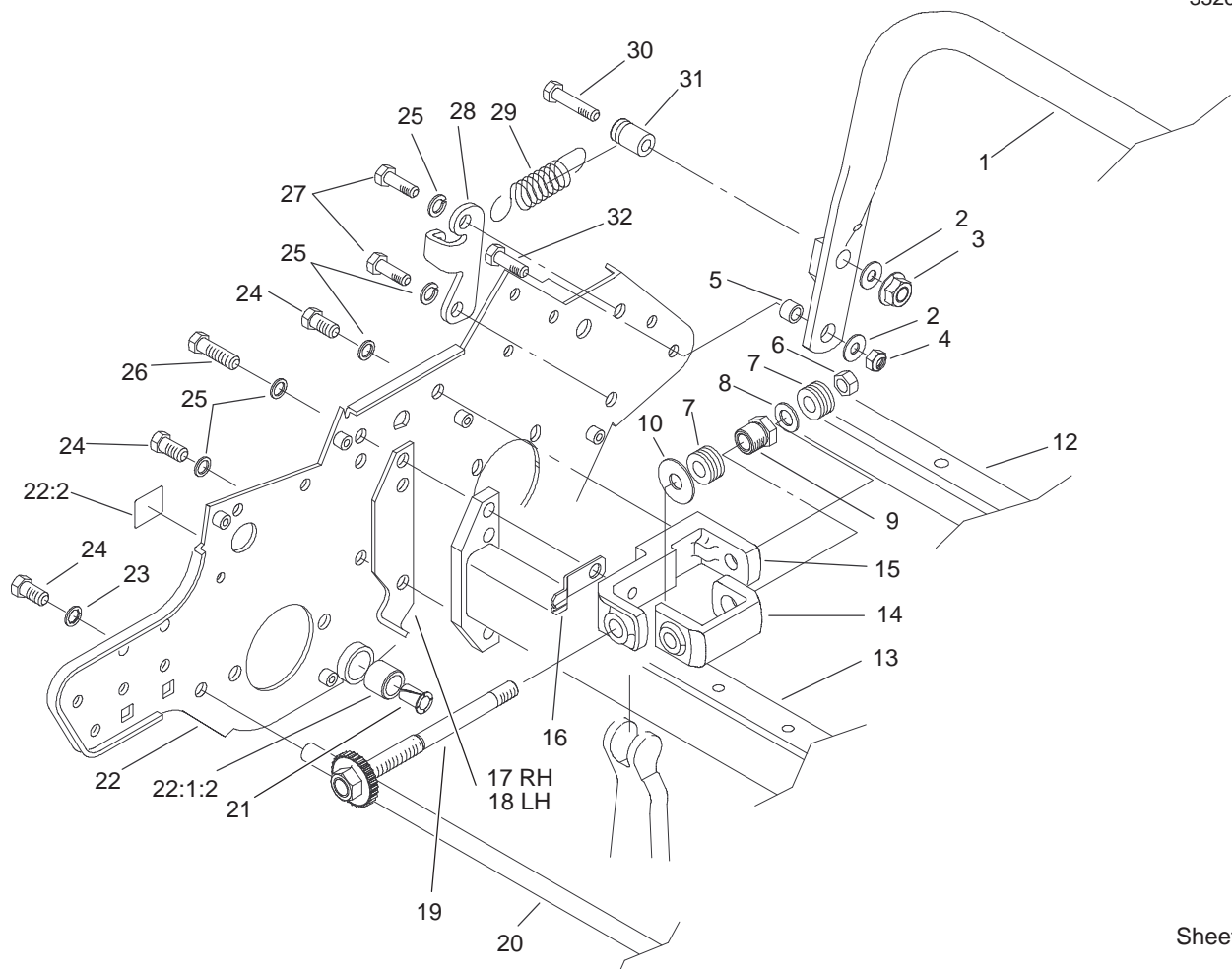

Sheet No.:2

Frame Assembly

Ref. No.	Part No.	Qty.	Description	Ref. No.	Part No.	Qty.	Description
1	65-7850-03	1	Kickstand	22:1:2	63-9510	1	Bushing
2	3256-2	3	Washer-Flat	22:2	93-9356	2	Decal-Warning, Belt
3	32128-25	1	Nut-Flange	22:2	93-9389	2	Decal-Warning, Belt (Japan)
4	3296-29	2	Nut-Lock, NI	23	3254-6	2	Washer-Lock, Internal
5	65-7910	2	Spacer	24	323-4	6	Screw-HH
6	3296-48	2	Nut-Lock NI	25	3253-21	8	Washer-Lock
7	93-9043	32	Washer-Spring, Belleville	26	323-6	2	Screw-HH
8	94-5858	2	Washer	27	323-5	2	Screw-HH
9	98-5913	2	Nut-Spring	28	65-7890	1	Bracket
10	94-5859	2	Washer-Hardened	29	65-7880	1	Spring-Extension
12	93-6025-01	1	Tube-Frame, Rear	30	322-10	1	Screw-HH
13	93-6054-01	1	Tube-Front	31	65-7900	1	Retainer-Spring
14	98-5912	2	Channel-Adjuster, Bedbar	32	322-5	2	Screw-HH
15	94-5854	2	Frame-Adjuster, Bedbar				
16	94-5856	2	Spring-Detent				
17	88-7100	1	Spacer-RH				
18	88-7090	1	Spacer-LH				
19	94-5873	2	Screw ASM				
20	88-7110	1	Rod-Frame Support				
21	52-2890	2	Bushing-Nylon				
22	93-6093	1	RH Side Plate ASM				
☆22:1		1	RH Sideplate/Bushing ASM				

☆ Not serviced separately

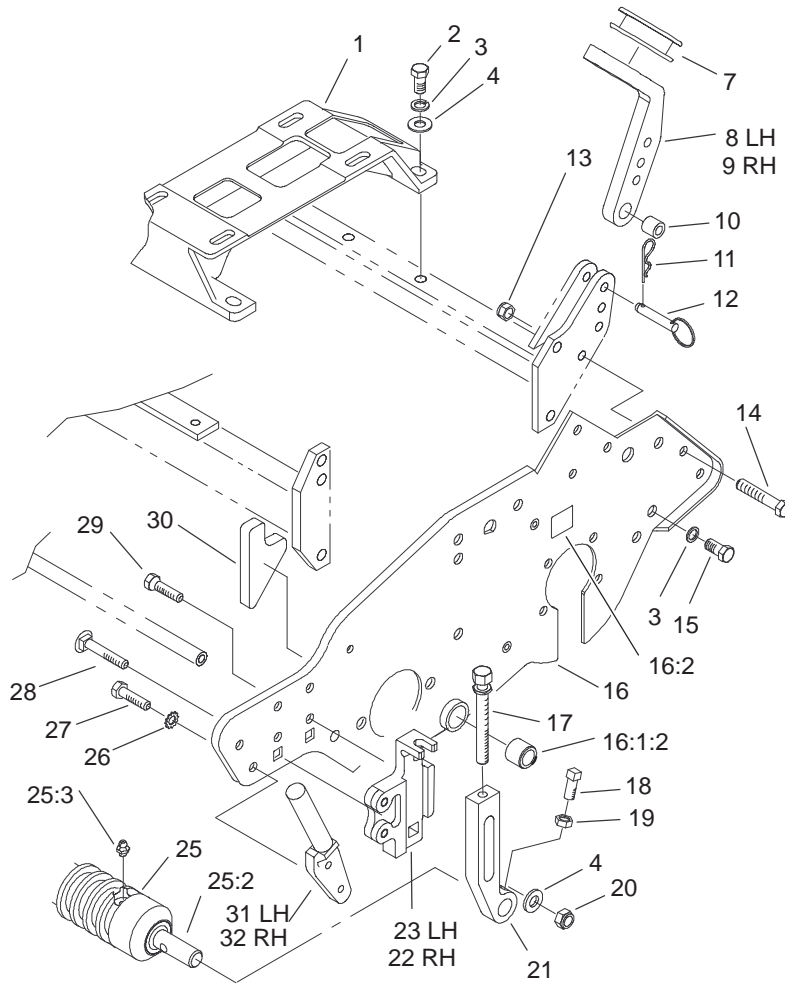

Sheet No.:3

Engine Mount and Frame Assembly

Ref. No.	Part No.	Qty.	Description
1	88-7670	1	Mount-Engine
2	323-5	4	Screw-HH
3	3253-21	8	Washer-Lock
4	3256-24	6	Washer-Flat
7	65-7510	2	Grommet-Handle
8	93-6038	1	Arm-Handle Support, LH
9	93-6037	1	Arm-Handle Support, RH
10	93-6024	2	Bushing-Support, Handle
11	3290-467	2	Pin-Hair
12	93-6029	2	Pin-Clevis, Ring
13	3296-29	2	Nut-Lock, NI
14	322-9	2	Screw-HH
15	323-4	4	Screw-HH
16	93-6094	1	LH Side Plate ASM
☆16:1		1	LH Sideplate/Bushing ASM
16:1:2	63-9510	1	Bushing
16:2	93-9356	1	Decal-Warning, Belt
16:2	93-9389	1	Decal-Warning, Belt (Japan)
17	93-6051	2	Screw-HOC
18	3242-4	2	Screw-Set, SQH
19	3218-2	2	Nut-Jam

Ref. No.	Part No.	Qty.	Description
20	32128-21	2	Nut-HF
21	93-6090	2	Arm-HOC
22	93-6048	1	Bracket-HOC, RH
23	93-6049	1	Bracket-HOC, LH
24	65-8570	2	Rod-Mounting
25	99-6241	1	Wiehle Roller ASM, .20 Spacing
25:2	52-3180	2	Bearing-Roller, Front
25:3	302-5	2	Fitting-Grease
26	3255-8	4	Washer-Lock/Ext
27	322-2	4	Screw-HH
28	3231-5	2	Screw-CARR
29	92-8914	4	Bolt-Tapered Face
30	93-6064	1	Seal-Catcher, Grass

☆ Not serviced separately

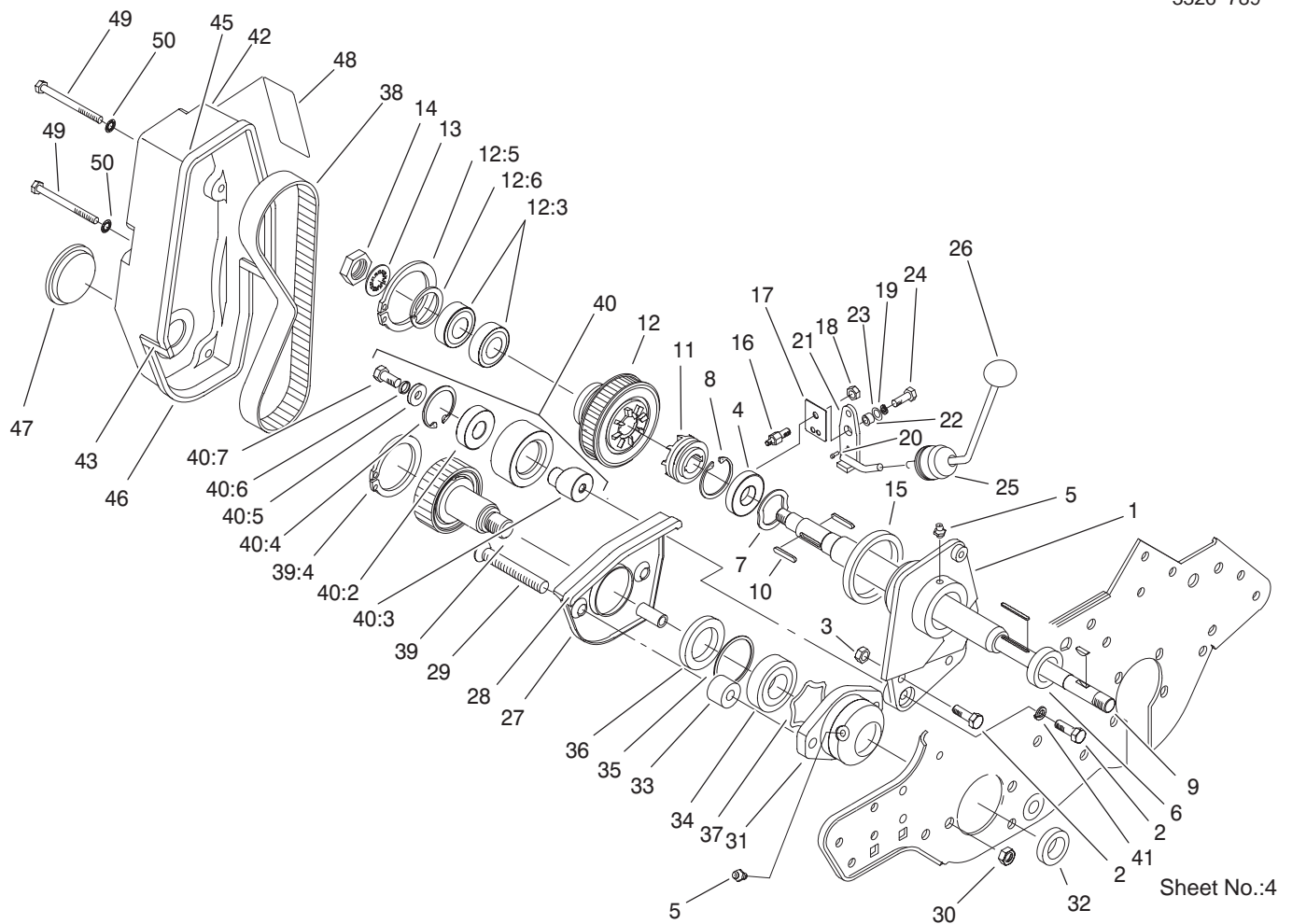

Reel Drive Assembly

Ref. No.	Part No.	Qty.	Description
1	92-8013	1	Housing-Clutch
2	322-5	3	Screw-HH
3	3296-29	2	Nut-Lock, NI
4	251-318	1	Bearing
5	302-5	2	Fitting-Grease
6	253-118	1	Seal-Oil
7	88-7720	1	Spring-Wave
8	32120-11	1	Ring-Retaining
9	93-6056	1	Shaft-Power
10	88-7150	2	Key
11	65-6940	1	Clutch-Slider, Jaw
12	88-7830	1	Clutch And Pulley ASM
12:3	251-336	2	Bearing
12:5	32151-95	1	Ring-Retaining
12:6	32151-89	1	Ring-Retaining, Bowed
13	3254-4	1	Washer-Lock/Int
14	3220-5	1	Nut-Jam
15	65-6970	1	Seal-Felt
16	93-9014	1	Pin-Clutch, Actuator
17	65-6290	1	Spring-Detent, Clutch
18	3296-42	1	Nut-Lock, NI
19	3253-3	1	Washer-Lock
20	95-5731	1	Screw-Drive
21	88-7170	1	Lever-Clutch

Ref. No.	Part No.	Qty.	Description
22	88-7860	1	Spacer-Clutch
23	3290-414	1	Washer-Belleville
24	321-4	1	Screw-HH
25	65-8960	1	Boot-Clutch
26	233-69	1	Knob
27	65-7190-01	1	Cover-Arm, Groomer
28	65-7131	1	Seal-Cover, Strip
29	3289-23	2	Capscrew
30	3296-39	2	Nut-Lock, NI
31	65-8640	1	Housing-Bearing
32	253-96	1	Seal-Oil
33	65-8290	2	Standoff-Cover
34	251-342	1	Bearing-Ball
35	32151-92	1	Ring-Retaining
36	253-163	1	Seal
37	3290-485	1	Washer-Wave
38	65-6200	1	Belt
39	88-7840	1	Pulley And Drive ASM
39:4	32151-95	1	Ring-Retaining
40	88-7850	1	Idle Pulley ASM
40:2	38-7820	1	Bearing-Ball
40:3	88-7190	1	Spacer
40:4	32120-42	1	Ring-Retaining
40:5	88-7200	1	Washer-Flat
40:6	3253-4	1	Washer-Lock
40:7	322-3	1	Screw-HH

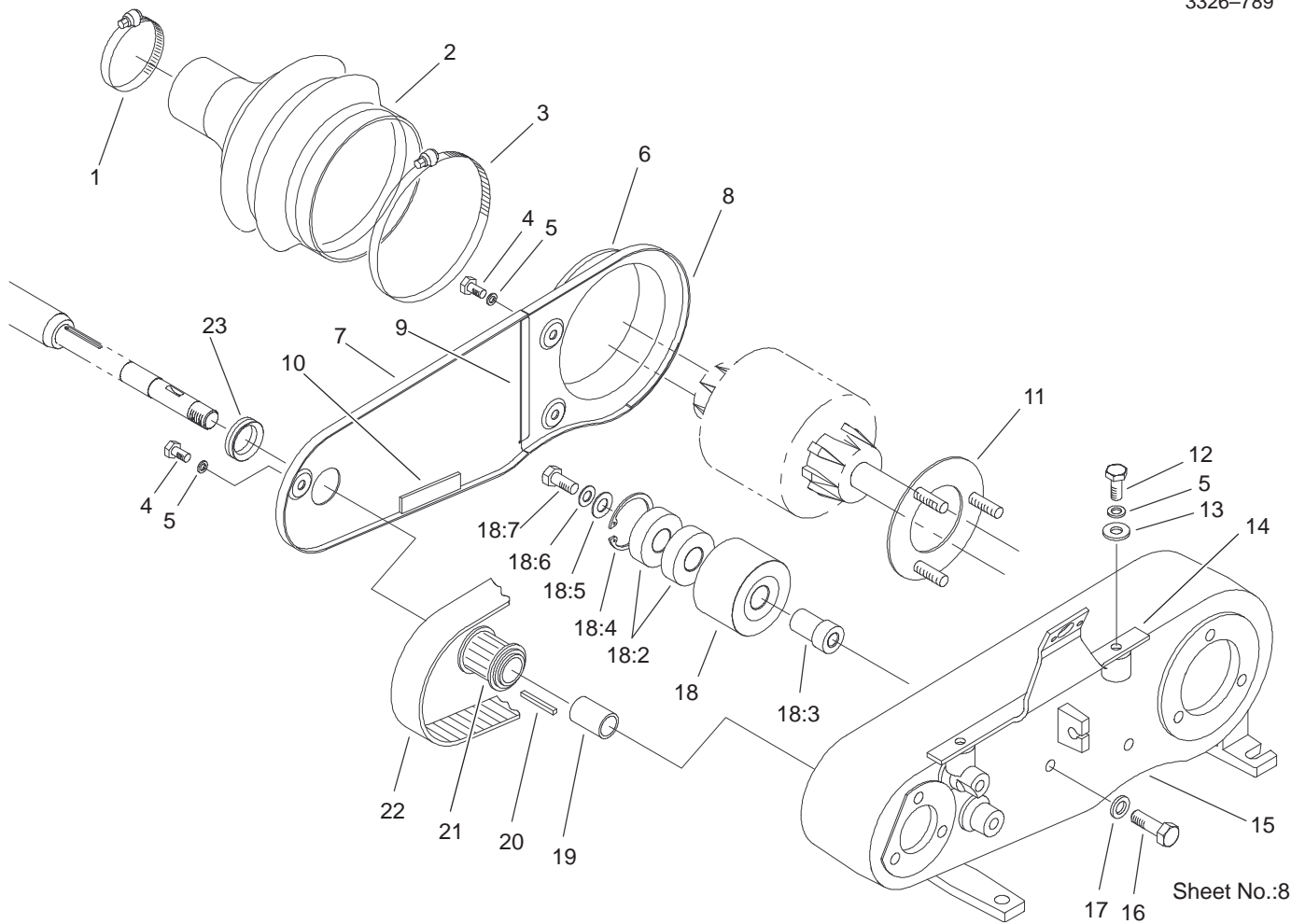

Sheet No.:8

Inner Crankshaft Assembly

Ref. No.	Part No.	Qty.	Description
1	2412-139	1	Clamp-Hose
2	65-6800	1	Boot-Differential
3	2412-140	1	Clamp-Hose
4	321-2	3	Screw-HH
5	3253-3	5	Washer-Lock
6	88-7250-03	1	Cover-Box, Rear
7	88-7240-03	1	Cover-Box, Front
8	65-6902	1	Strip-Seal, Cover
9	65-6903	1	Strip-Seal, Cover
10	65-6901	1	Strip-Seal, Cover
11	65-6720	1	Plate-Screw
12	321-3	2	Screw-HH
13	3256-22	2	Washer-Flat
14	93-1448	1	Bracket Cover ASM
15	88-7230	1	Housing-Shaft, Counter
16	322-5	1	Screw-HH
17	3253-4	1	Washer-Lock
18	88-7870	1	Idler Pulley ASM
18:2	38-7820	2	Bearing-Ball
18:3	88-7380	1	Spacer-Pulley
18:4	32120-42	1	Ring-Retaining
18:5	88-7200	1	Washer-Flat
18:6	3253-4	1	Washer-Lock
18:7	322-3	1	Screw-HH
19	86-7140	1	Spacer

Ref. No.	Part No.	Qty.	Description
20	65-6850	1	Key-Square
21	65-8910	1	Pulley-Countershaft
22	65-9080	1	Belt
23	88-7710	1	Seal-V-Ring

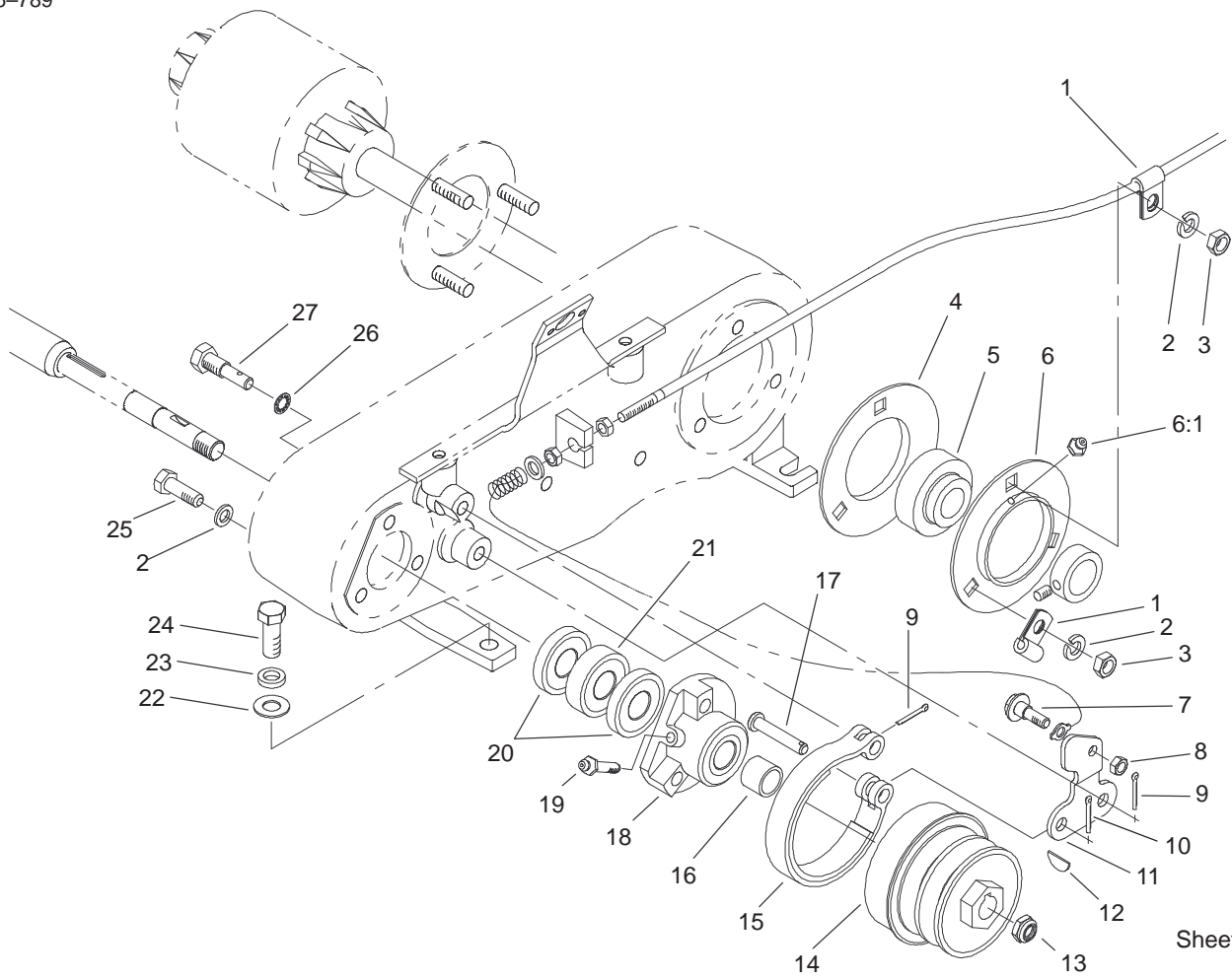

Sheet No.:9

Outer Crankshaft Assembly

Ref. No.	Part No.	Qty.	Description
1	88-7970	2	Clip
2	3253-4	6	Washer-Lock
3	3218-2	3	Nut-Jam
4	65-6710	1	Flangette-Bearing
5	251-343	1	Bearing-Ball
6	65-6700	1	Flangette-Lube
6:1	302-65	1	Zerk
7	11-9030	1	Screw-Shoulder
8	3296-42	1	Nut-Lock, NI
9	3272-6	2	Pin-Cotter
10	3272-8	1	Pin-Cotter
11	65-8610	1	Lever-Brake
12	3257-30	1	Key-Woodruff
13	3296-57	1	Nut-Lock, NI
14	92-9212	1	Pulley-Shaft, Input
15	65-8700	1	Band-Brake
16	86-7130	1	Spacer-Pulley
17	283-75	1	Pin-Clevis
18	65-6760	1	Housing-Bearing
19	302-64	1	Fitting-Grease
20	253-160	2	Seal-Grease
21	251-338	1	Bearing-Ball
22	3256-24	4	Washer-Flat
23	3253-21	4	Washer-Lock
24	323-5	4	Screw-HH
25	322-5	3	Screw-HH

Ref. No.	Part No.	Qty.	Description
26	3254-6	2	Washer-Lock, Internal
27	65-6810	2	Support-Brake

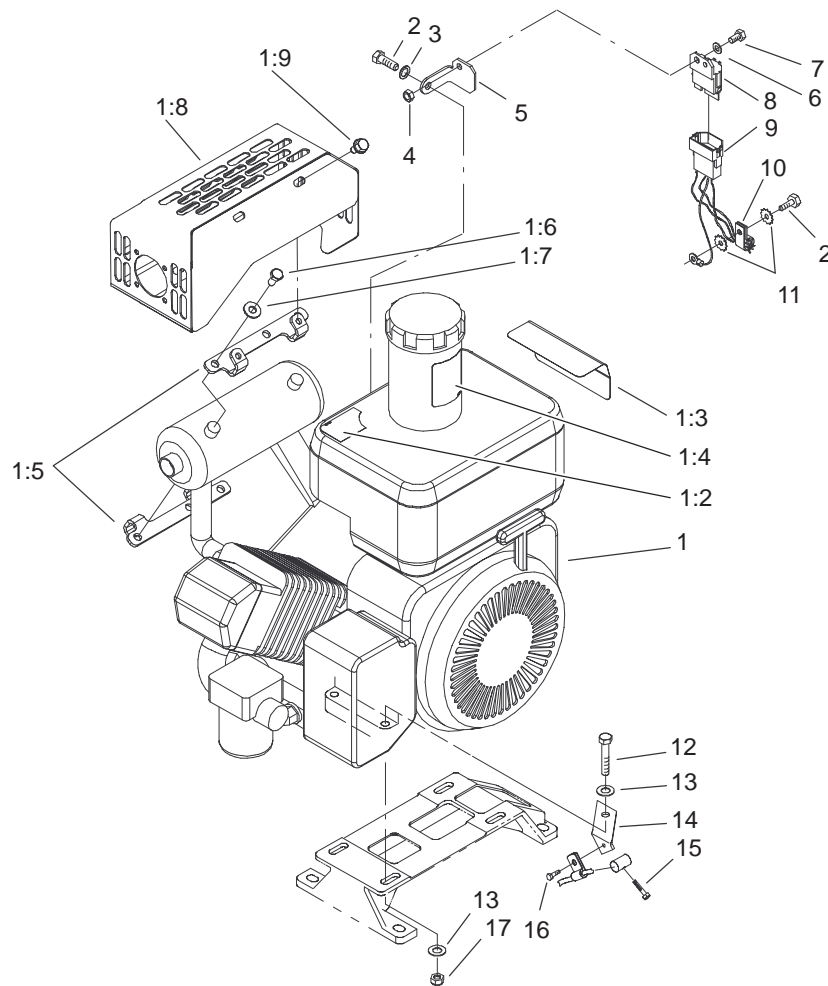

Sheet No.:10

Engine Assembly

Ref. No.	Part No.	Qty.	Description	Ref. No.	Part No.	Qty.	Description
1	105-5355	1	Engine ASM	14	88-7960	1	Bracket-Cable, Throttle
1:2	105-5309	1	Decal-Hot Surface	15	94-9015	1	Screw-HH
1:2	83-2560	1	Decal-Surface, Hot (Japan)	16	104-2065	1	Screw-HWH
1:3	92-4813	1	Decal-Danger (Japan)	17	3296-29	4	Nut-Lock, NI
1:3	93-7348	1	Decal-Danger				
1:4	93-9886	1	Decal-Fuel				
1:5	104-9771-03	2	Bracket-Guard, Muffler				
1:6	33113-012	4	Screw-HH				
1:7	3256-22	4	Washer-Flat				
1:8	104-9784-03	1	Guard-Muffler				
1:9	104-2628	4	Screw-HWH				
2	33114-016	2	Screw-HH				
3	3253-4	1	Washer-Lock				
4	3296-42	1	Nut-Lock, NI				
5	94-5861	1	Bracket-Module				
6	3256-22	1	Washer-Flat				
7	321-3	1	Screw-HH				
8	94-3431	1	Module-Interlock				
9	105-5351	1	Harness-Wire, Module				
10	2412-134	1	R-Clamp				
11	3255-9	2	Washer-Lock/Ext				
12	322-9	4	Screw-HH				
13	3256-56	5	Washer-Flat				

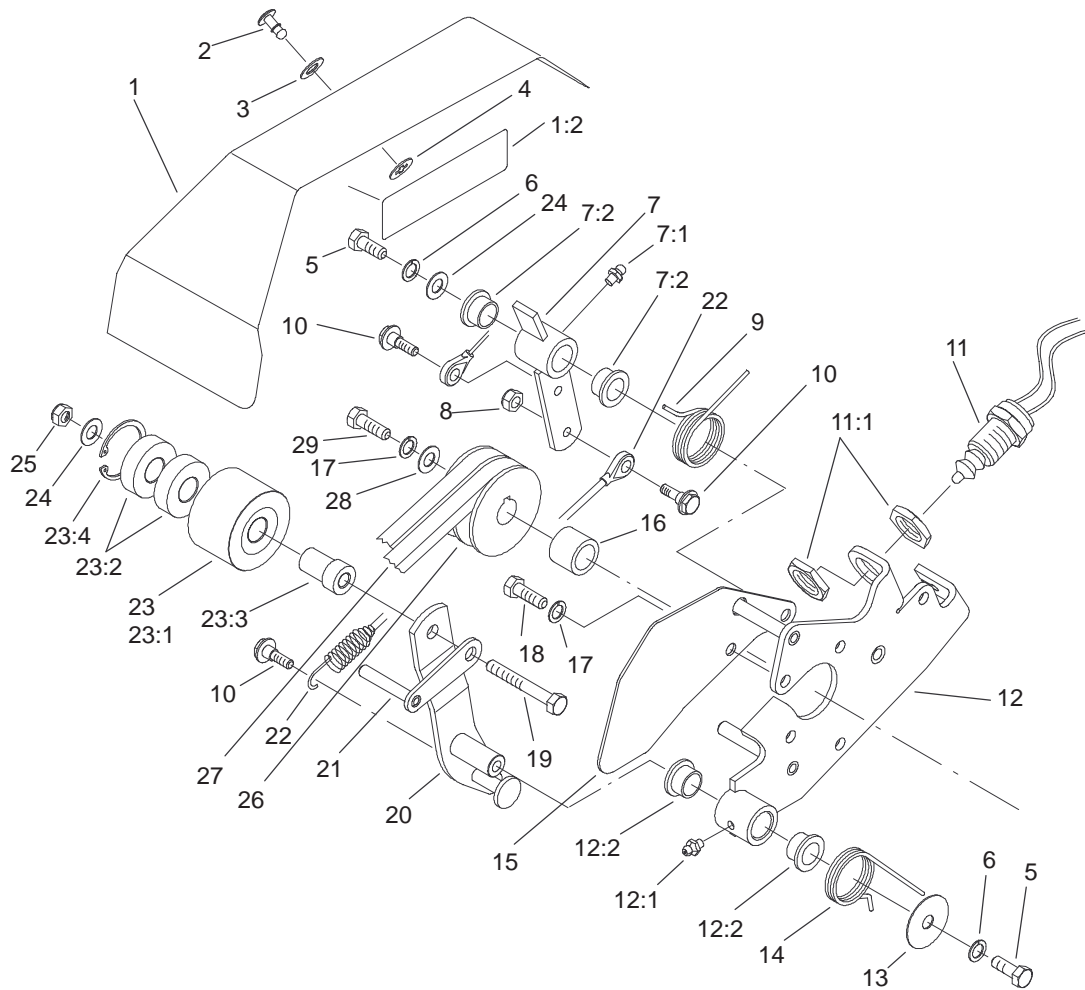

Sheet No.:11

Bellcrank Assembly

Ref. No.	Part No.	Qty.	Description
1	94-9007	1	Bellcrank Cover ASM
1:2	84-7280	1	Decal-Danger, Japan
1:2	93-7273	1	Decal-Danger
2	93-6074	1	Stud
3	3256-2	1	Washer-Flat
4	93-6073	1	Retainer
5	323-4	2	Screw-HH
6	3253-21	2	Washer-Lock
7	93-6014	1	Lever ASM
7:1	302-5	1	Fitting-Grease
7:2	65-8770	2	Bushing-Bellcrank
8	3296-42	3	Nut-Lock, NI
9	93-6011	1	Spring-Torsion
10	11-9030	3	Screw-Shoulder
11	87-5490	1	Switch-Clutch
11:1	3218-20	2	Nut-Jam
12	93-6015	1	Clutch Bracket ASM
12:1	302-5	1	Fitting-Grease
12:2	65-8770	2	Bushing-Bellcrank
13	93-6099	1	Washer
14	93-6012	1	Spring-Torque, Clutch Lever
15	93-6013-03	1	Shield-Belt
16	65-8260	1	Spacer-Shaft, Engine
17	3253-4	6	Washer-Lock
18	33114-016	5	Screw-HH

Ref. No.	Part No.	Qty.	Description
19	323-11	1	Screw-HH
20	93-6003-03	1	Lever-Clutch
21	95-0922	1	Guide-Belt
22	93-9024	1	Cable Link ASM
23	98-7296	1	Idler Pulley ASM
23:1	98-7297	1	Pulley-Idler
23:2	38-7820	2	Bearing-Ball
23:3	88-7350	1	Bushing-Pulley
23:4	32120-42	1	Ring-Retaining
24	3256-56	5	Washer-Flat
25	3296-39	1	Nut-Lock, NI
26	92-9216	1	Pulley-Drive, Input
27	92-9218	1	V-Belt (Matched Set)
28	65-8270	1	Washer
29	33114-025	1	Screw-HH

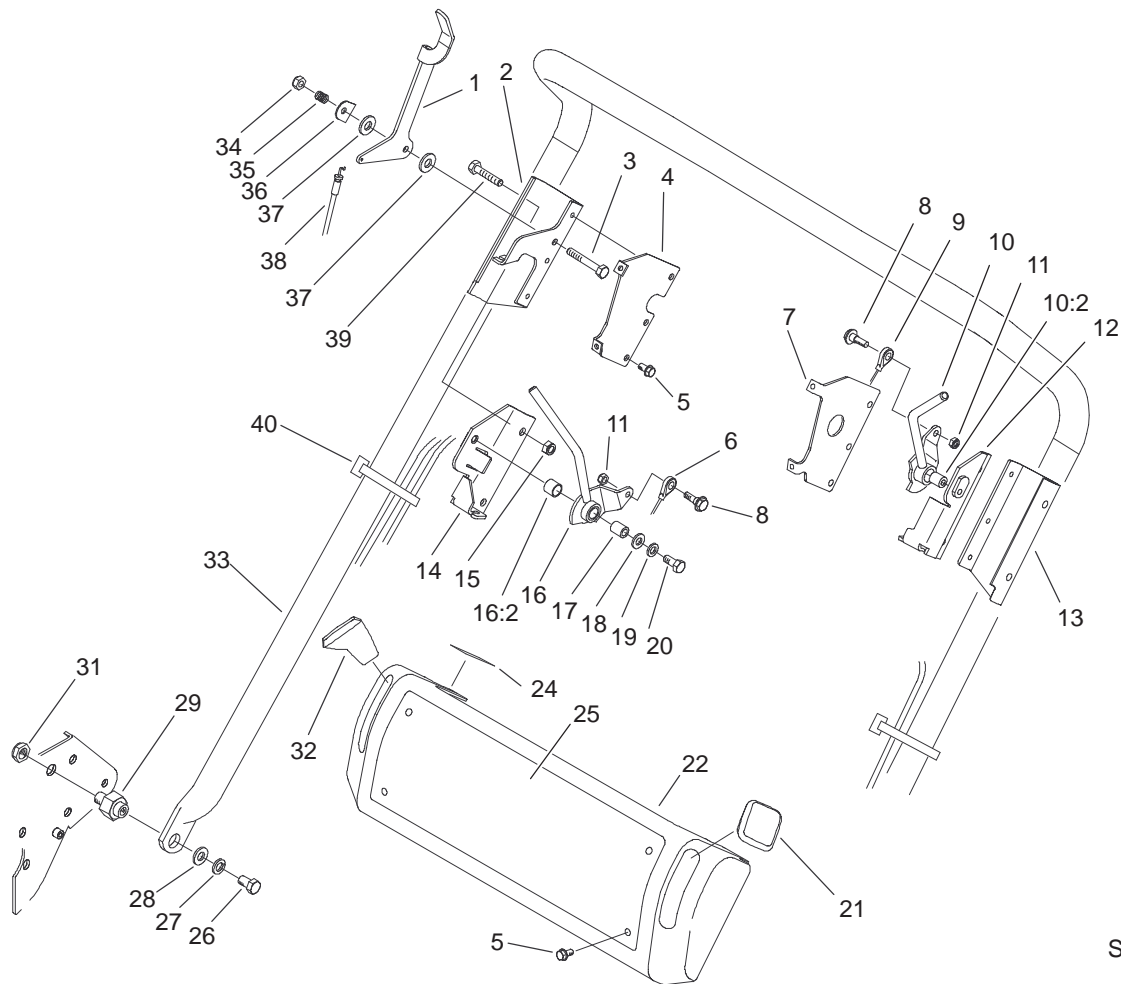

Sheet No.:12

Handle and Controls Assembly

Ref. No.	Part No.	Qty.	Description
1	93-6017	1	Lever-Throttle
2	95-0908-03	1	Bracket-Clutch, Skid
3	321-8	1	Screw-HH
4	93-6046-03	1	Bracket-Console, RH
5	93-6083	10	Screw-HWH
6	94-5870	1	Cable Clutch ASM
7	93-6047-03	1	Bracket-Console, LH
8	11-9030	2	Screw-Shoulder
9	94-5871	1	Cable Brake ASM
10	93-6058	1	Brake Lever ASM
10:2	256-206	1	Bushing
11	3296-42	2	Nut-Lock, NI
12	93-6022	1	Bracket-Brake
13	95-0907-03	1	Bracket-Brake, Skid
14	93-6019	1	Bracket
15	3296-29	4	Nut-Lock, NI
16	95-5715	1	Clutch Lever ASM
16:2	256-206	1	Bushing
17	88-7450	2	Spacer-Lever, Control
18	3256-23	2	Washer-Flat
19	3253-4	2	Washer-Lock
20	3210-7	2	Screw-HH
21	65-8971	1	Knob-Shift
22	93-6036	1	Cover-Console
24	93-6085	1	Decal-Throttle
25	105-5360	1	Decal-Console

Ref. No.	Part No.	Qty.	Description
26	323-34	2	Screw-HH
27	3253-21	2	Washer-Lock
28	3256-24	2	Washer-Flat
29	93-6000	2	Pin-Pivot, Handle
31	3296-28	2	Nut-Lock, NI
32	65-8970	1	Knob-Shift
33	93-6001	1	Handle
34	3296-56	1	Nut-Lock, NI
35	3-5787	1	Spring-Compression
36	93-6016	1	Washer-Retaining
37	66-2921	2	Washer-Friction
38	94-5869	1	Throttle Cable ASM
39	322-9	4	Screw-HH
40	3290-378	2	Tie-Cable

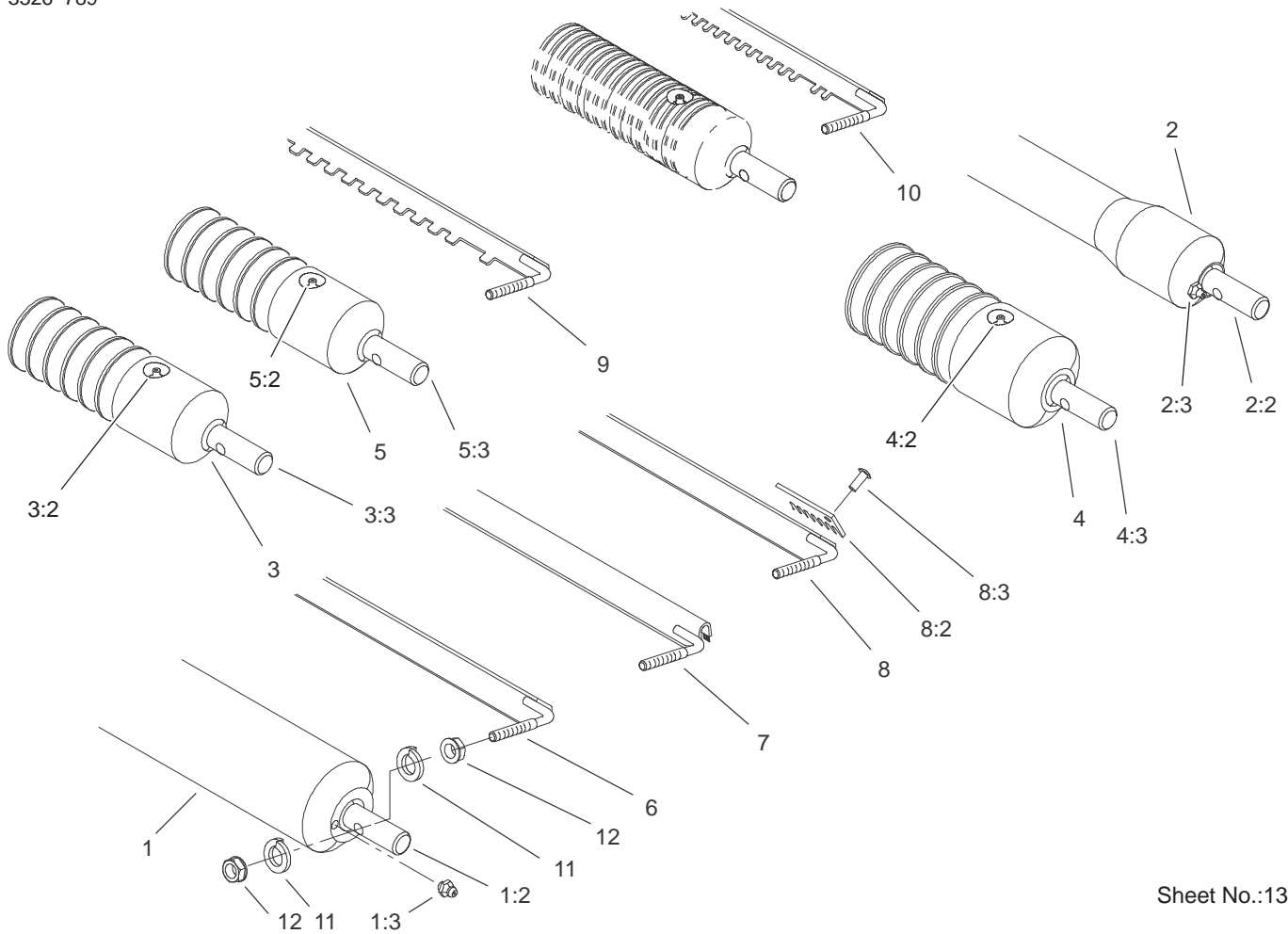

Sheet No.:13

Roller and Scraper Options

Ref. No.	Part No.	Qty.	Description
1	104-2642	1	Full Roller ASM, 21 Inch
1:2	52-3180	2	Bearing-Roller, Front
1:3	302-5	2	Fitting-Grease
2	52-3590	1	Swaged Roller ASM
2:2	52-3180	2	Bearing-Roller, Front
2:3	302-5	2	Fitting-Grease
3	71-1550	1	Wiehle Roller ASM, Cast Iron
3:2	302-5	2	Fitting-Grease
3:3	52-3180	2	Bearing-Roller, Front
4	93-9045	1	Wiehle Roller ASM, 2.5 Inch Diameter
4:2	302-5	2	Fitting-Grease
4:3	52-3180	2	Bearing-Roller, Front
5	88-6790	1	Wiehle Roller ASM, .43 Spacing
5:2	302-5	2	Fitting-Grease
5:3	52-3180	2	Bearing-Roller, Front
6	65-8360-01	1	Scraper-Smooth
7	33-1000	1	Scraper Brush ASM
8	11-0070	1	Scraper Comb ASM
8:2	8-2530	1	Comb
8:3	3295-2	11	Rivet-Semi
9	65-8340-01	1	Scraper-Wiehle, .43 Spacing

Ref. No.	Part No.	Qty.	Description
10	104-0509-01	1	Scraper-Wiehle, .20 Spacing
11	3254-8	4	Washer-Lock
12	3219-1	4	Nut-Hex

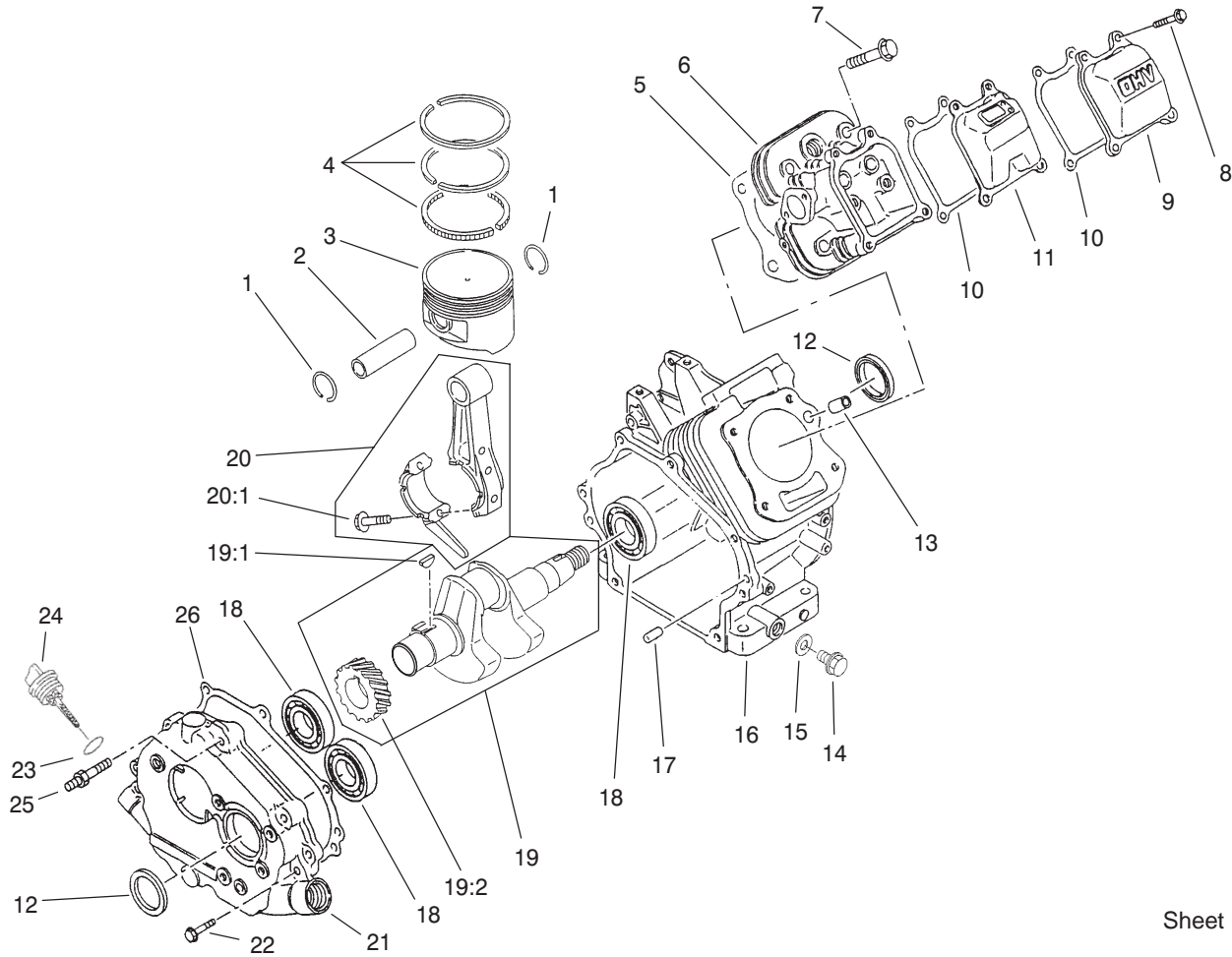

Sheet No.:50
T-3472

Crankcase Assembly

Ref. No.	Part No.	Qty.	Description
1	93-8500	2	Ring-Retaining
2	93-8501	1	Pin-Piston
3	93-8502	1	Piston
3	94-6836	1	Piston-0.5 O/S
4	93-8503	1	Set-Ring, Piston
4	94-6837	1	Set-Ring, Piston (.05mm)
5	93-8504	1	Gasket-Head
6	93-8505	1	Head-Cylinder
7	93-8506	4	Bolt-Flanged
8	94-6838	4	Bolt-Flanged
9	93-8508	1	Case-Rocker
10	93-8509	2	Gasket-Rocker
11	93-8510	1	Breather
12	93-8511	2	Seal-Oil
13	93-8512	2	Pin
14	93-8513	2	Plug-Drain
15	93-8514	2	Gasket-Plug, Drain
16	93-8515	1	Crankcase
17	93-8516	2	Pin
18	93-8517	2	Bearing-Ball
19	93-8518	1	Crankshaft ASM
19:1	93-8526	1	Key
19:2	94-9043	1	Gear-Helical
20	93-8528	1	Connecting Rod ASM
20:1	93-8527	2	Bolt-Rod

Ref. No.	Part No.	Qty.	Description
21	93-8520	1	Cover-Crankcase
22	93-8521	7	Bolt-Flanged
23	94-9041	2	O-Ring
24	93-8523	2	Cap-Filter, Oil
25	93-8524	1	Stud
26	93-8525	1	Gasket-Crankcase

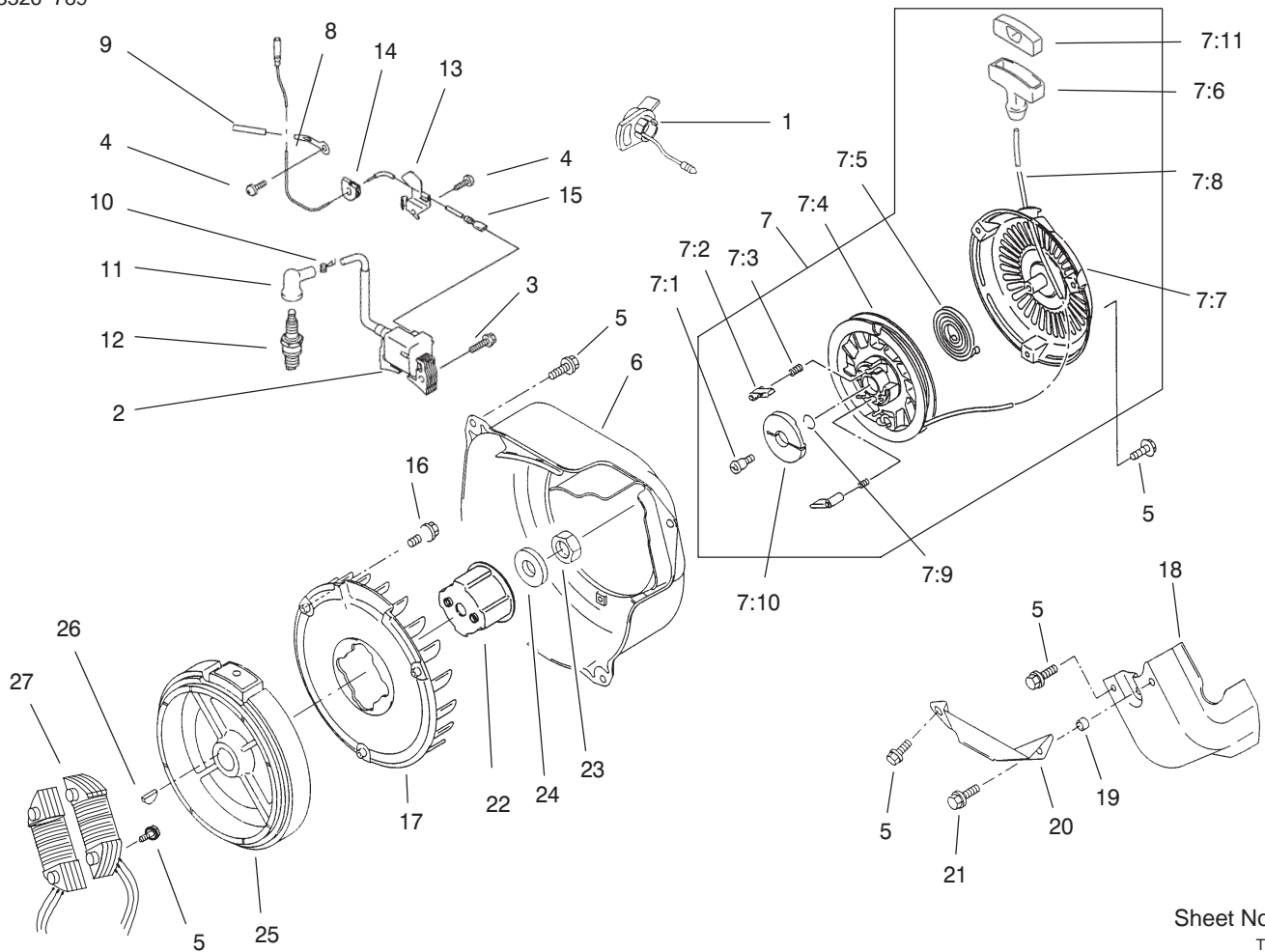

Sheet No.:52

T-3465

Ignition Assembly

Ref. No.	Part No.	Qty.	Description
1	93-8546	1	Switch
2	94-9031	1	Ignition Coil ASM
3	93-8548	6	Bolt-Flanged
4	93-8549	2	Screw
5	93-8550	10	Bolt-Flanged
6	94-9047	1	Housing-Fan
7	93-8552	1	Recoil Starter ASM
7:1	93-8553	1	Screw
7:2	93-8554	2	Pawl-Recoil
7:3	93-8555	2	Spring-Return
7:4	93-8556	1	Reel-Recoil
7:5	93-8557	1	Spring
7:6	94-9045	1	Grip-Starter, Recoil
7:7	94-9046	1	Case-Recoil
7:8	93-8560	1	Rope
7:9	93-8561	1	Ring-Retaining
7:10	93-8562	1	Guide-Pawl
7:11	94-9044	1	Cap-Grip
8	94-9039	1	Clamp
9	94-9040	1	Tube
10	94-9049	1	Spring-Terminal
11	93-8585	1	Cap-Plug, Spark
12	93-8584	1	Spark Plug
13	93-8583	1	Clamp
14	93-8582	1	Grommet
15	94-9038	1	Wire-Lead

Ref. No.	Part No.	Qty.	Description
16	94-6840	3	Bolt-Flanged
17	93-8572	1	Fan
18	93-8563	1	Shroud-Engine
19	93-8564	1	Collar
20	93-8565	1	Shroud-Engine
21	93-8566	1	Bolt-Flanged
22	93-8567	1	Pulley-Recoil
23	93-8568	1	Nut
24	93-8569	1	Washer
25	99-6237	1	Flywheel ASM
26	93-8571	1	Key
27	99-4267	1	Coil-Lighting

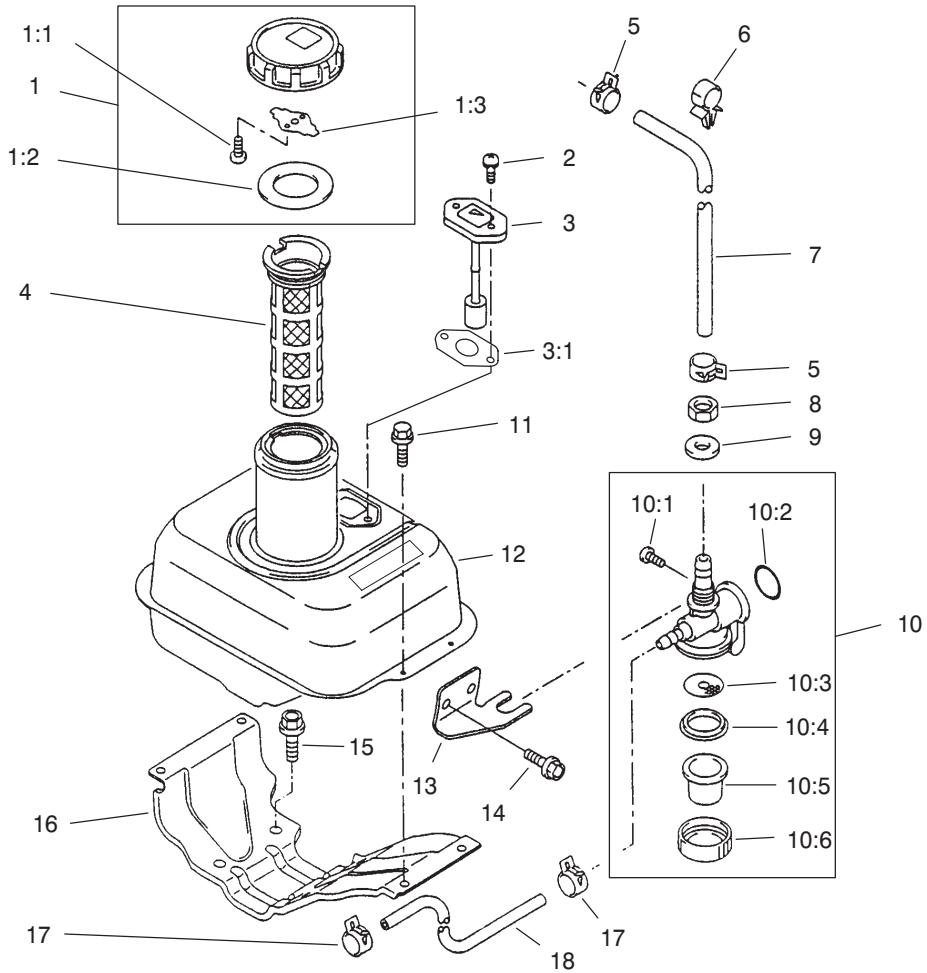

Sheet No.:56
T-3477

Fuel Tank Assembly

Ref. No.	Part No.	Qty.	Description
1	93-8660	1	Fuel Cap ASM
1:1	93-8661	2	Screw
1:2	93-8662	1	Gasket
1:3	93-8663	1	Spring
2	93-8686	2	Screw
3	93-8685	1	Gauge-Fuel
3:1	104-2384	1	Gasket-Gauge, Fuel
4	94-6826	1	Filter-Fuel
5	93-8664	2	Clamp
6	93-8665	1	Clamp
7	93-8666	1	Tube
8	94-9042	1	Nut
9	93-8668	1	Washer
10	93-8669	1	TAP ASM
10:1	93-8670	1	Screw
10:2	93-8671	1	O-Ring
10:3	94-6849	1	Filter-TAP
10:4	93-8673	1	Gasket
10:5	93-8674	1	Cup-TAP
10:6	93-8675	1	Nut
11	93-8683	4	Bolt
12	104-2382	1	Tank-Fuel
13	93-8681	1	Bracket
14	93-8680	2	Bolt-Flanged
15	94-6825	4	Bolt-Flanged
16	104-2383	1	Bracket-Tank

Ref. No.	Part No.	Qty.	Description
17	93-8676	2	Clamp
18	93-8677	1	Tube

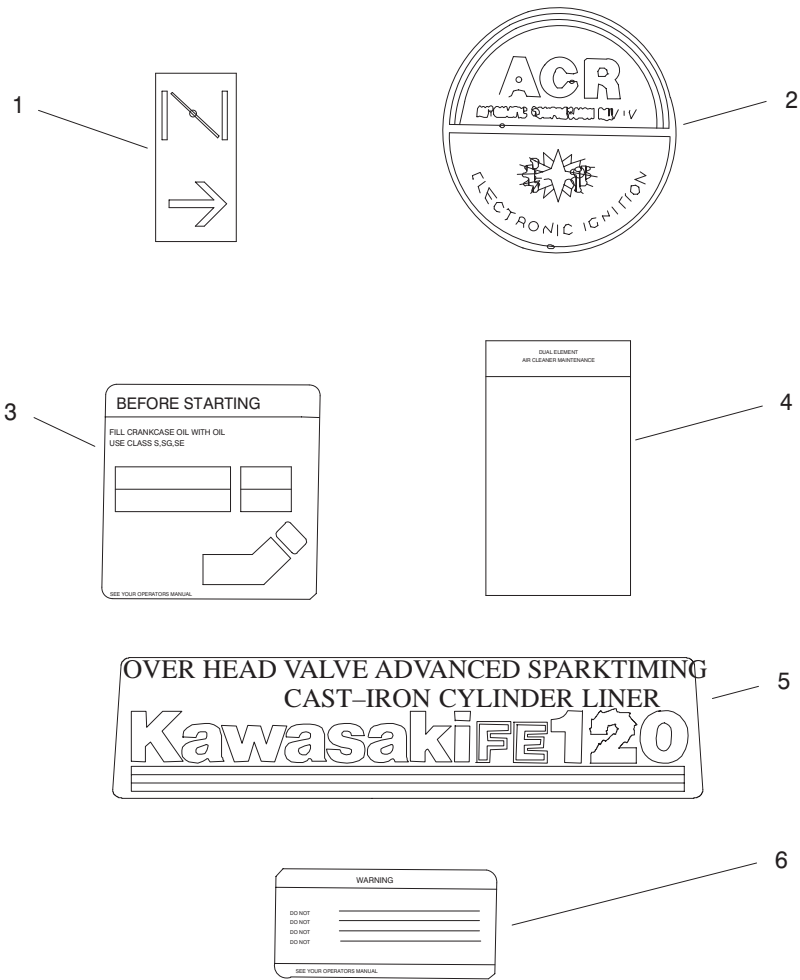

Sheet No.:57
T-3478

Decals

Ref. No.	Part No.	Qty.	Description
1	93-8687	1	Decal-Choke
2	94-9027	1	Label-Recoil
3	93-8689	1	Decal-Instructions
4	93-8690	1	Decal-Maintenance
5	94-9028	1	Label-Kawasaki
6	93-8692	1	Decal-Warning

Ref. No.	Part No.	Qty.	Description

Special Tools

Bedknife Screw Tool No. *TOR510880

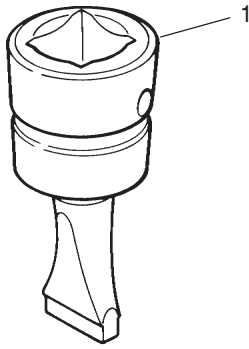

T-0729

Ref. No.	Part No.	Description	No. Used
1		Tool-Bedknife, Screw	1

Backlapping Brush Assembly No. *TOR299100

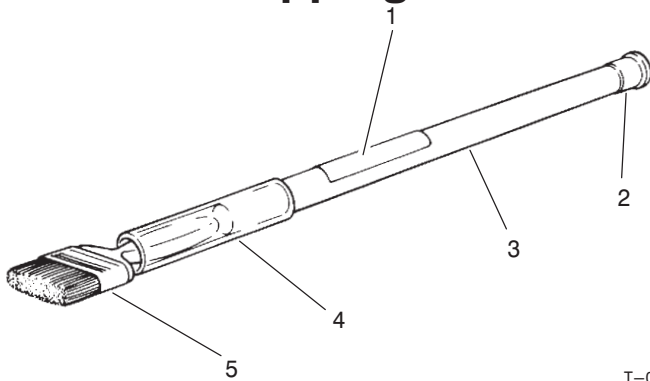

T-0731

Ref. No.	Part No.	Description	No. Used
1	12-9140	Decal	1
2	2410-18	Plug	1
3	29-9080	Handle	1
4	29-9090	Hose-Handle	1
5	36-4310	Brush	1

*Obtain these items directly from OTC 2013 4th St. Owatonna, MN. 55060 1-800-533-0492
 (in Minnesota and Canada 1-507-455-7050) Fax. 507-455-7011.

