



36" Tiller

Wheel Horse® Classic Garden Tractor Attachment

Model No. 79370—Serial No. 230000001 and Up

Operator's Manual

Contents

	Page
Introduction	2
Safety	3
Slope Chart	3
Safety and Instruction Decals	5
Setup	5
Loose Parts	5
Installing the Tiller Hitch and Pulleys	7
Installing the Rear Shield	7
Installing the Lift Cable and Lift Lever	7
Removing the Drawbar	9
Assembling the Mounting Plate	9
Installing the Mounting Plate	9
Installing the Idler Arm Pulley Assembly	10
Installing the Tiller to the Tractor	10
Operation	11
Operating the Power Take Off (PTO)	11
Operating the Attachment Lift Lever	12
Operating the Attachment Power Lift	12
Adjusting Dial-A-Height	13
Adjusting Lift Chain	13
Removing the Tiller	13
Tips for Tilling	14
Maintenance	15
Recommended Maintenance Schedule	15
Service Interval Chart	15
Greasing and Lubrication	16
Adjusting Drive Belt Tension	16
Replacing the Power Take Off (PTO) Belt	16
Storage	19

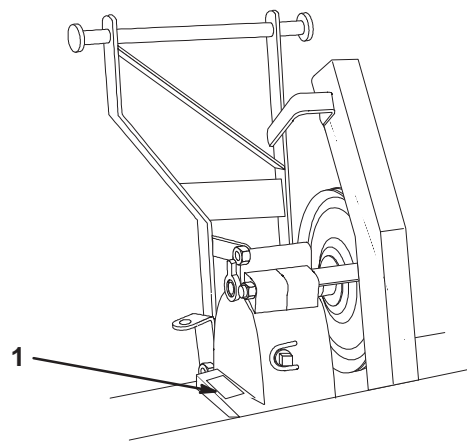

2276

Figure 1

1. Location of the model and serial numbers

Write the product model and serial numbers in the space below:

Model No. _____
Serial No. _____

This manual identifies potential hazards and has special safety messages that help you and others avoid personal injury and even death. **Danger**, **Warning**, and **Caution** are signal words used to identify the level of hazard. However, regardless of the hazard, be extremely careful.

Danger signals an extreme hazard that *will* cause serious injury or death if you do not follow the recommended precautions.

Warning signals a hazard that *may* cause serious injury or death if you do not follow the recommended precautions.

Caution signals a hazard that may cause minor or moderate injury if you do not follow the recommended precautions.

This manual uses two other words to highlight information.

Important calls attention to special mechanical information and **Note:** emphasizes general information worthy of special attention.

Introduction

Read this manual carefully to learn how to operate and maintain your product properly. The information in this manual can help you and others avoid injury and product damage. Although Toro designs and produces safe products, you are responsible for operating the product properly and safely.

Whenever you need service, genuine Toro parts, or additional information, contact an Authorized Service Dealer or Toro Customer Service and have the model and serial numbers of your product ready. Figure 1 illustrates the location of the model and serial numbers on the product.

Safety

Slope Chart

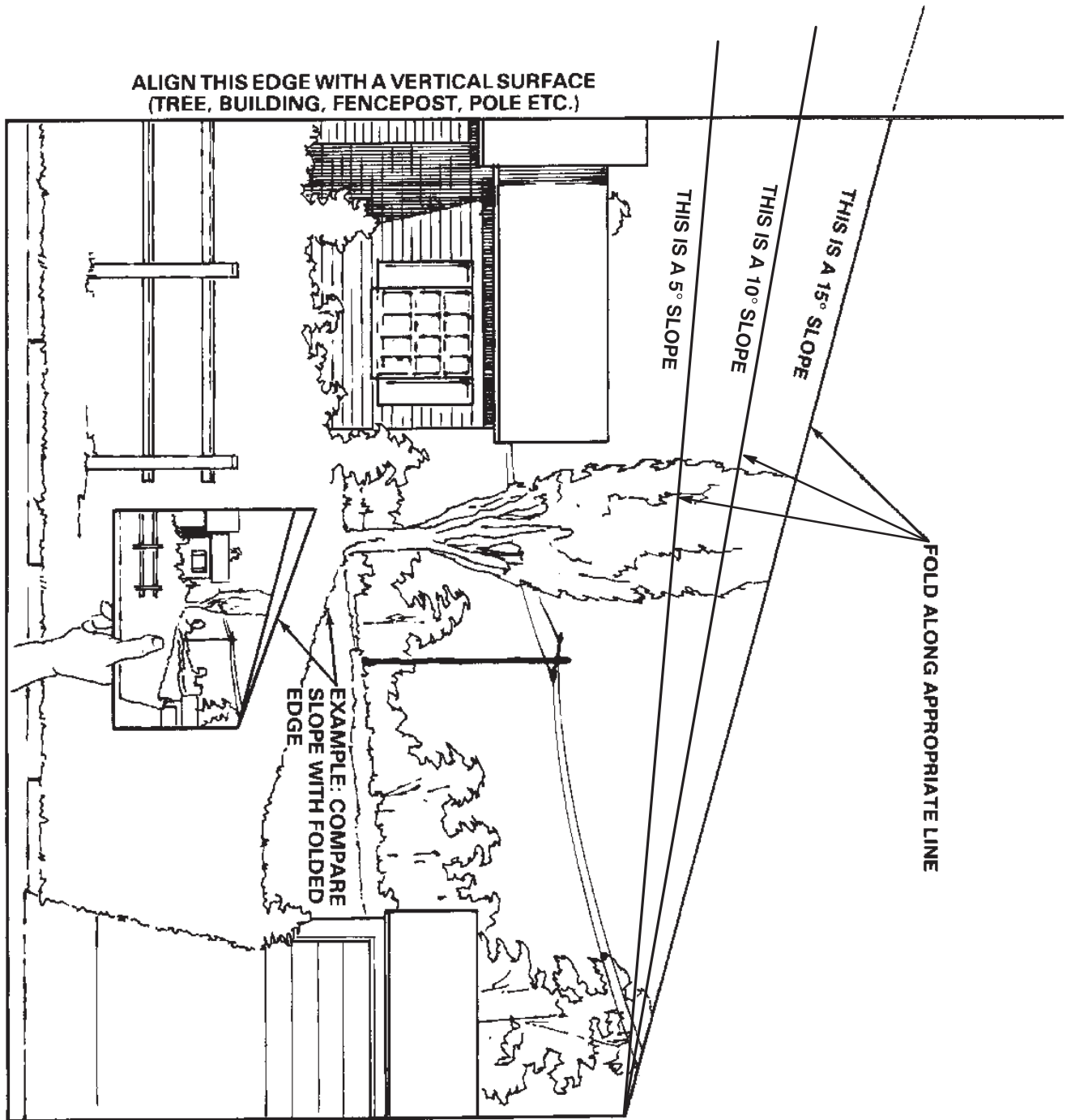

Safety and Instruction Decals



Safety decals and instructions are easily visible to the operator and are located near any area of potential danger. Replace any decal that is damaged or lost.

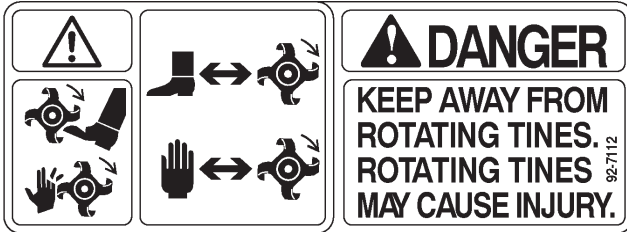

92-7112

Setup

Note: Determine the left and right sides of the machine from the normal operating position.

Loose Parts

Note: Use the chart below to identify parts for assembly.

DESCRIPTION	QTY.	USE
Hitch	1	Installing the tiller hitch and pulleys
Spring bracket	1	
Bolt, 3/8 x 5-1/2 inch (installed in gear case for shipping)	1	
Bolt, 3/8 x 4-1/2 inch (installed in gear case for shipping)	1	
Nut, 3/8 inch (installed in case for shipping)	2	
Pulley	1	
Key	1	
Set screw, 5/16 inch	2	
Idler pulley	1	
Spacer	1	
Belt guide	1	
Belt guard	1	
Bolt, 3/8 x 1-5/8 inch	1	
Lock nut, 3/8 inch	1	
Rear shield	1	Installing the rear shield and lift chain
Cotter pin, 1 inch	3	
Lift chain	1	
Clevis	1	

DESCRIPTION	QTY.	USE
Tube—Hydro drive	1	Installing the lift cable and lift lever
Tube—Gear drive	1	
Clamp	1	
Cable	1	
Clevis—Long	1	
Clevis—Short	1	
Clevis pin	1	
Cotter pin, 1 inch	2	
Trunnion	1	
Washer, 3/8 inch	1	
Lift lever	1	
Bushing	2	
Shim washer	4	
E-ring	2	
Latching plate	1	Assembling the mounting plate
Latch lever	2	
Carriage bolt, 3/8 x 1 inch	2	
Washer, 3/8 inch	2	
Lock nut, 3/8 inch	2	
Latch plate assembly	1	Installing the mounting plate
Link bracket-right	1	
Link bracket-left	1	
Angle spacer (if required)	1	
Carriage bolt 3/8 x 3-1/2 inch	4	
Lock nut, 3/8 inch	4	
Idler arm assembly	1	Install idler arm pulley assembly
Idler bracket	1	
Spring—large	1	Installing the tiller to the tractor
Eye bolt	1	
Lock nut, 3/8 inch	1	
Clevis pin	2	
Cotter pin, 3/4 inch	2	
Belt	1	
Bolt 3/8 x 1-1/4 inch	1	
Lock nut, 3/8 inch	2	
Spring—small	1	
Belt guard	1	
Bolt-self tapping, 1/4 x 1/2 inch	2	

Installing the Tiller Hitch and Pulleys

1. Tip tiller onto back and support in an upright position. Remove the 3/8 x 5-1/2 inch bolt and the 3/8 x 4-1/2 inch bolt from the tiller gear case (Fig. 2). Discard extra nuts used as spacers for shipping.
2. Fasten hitch and spring bracket to gear case with the bolt (3/8 x 5-1/2 inch) and nut (3/8 inch) shown in Figure 2.

Note: Make sure the 3/8 x 4-1/2 inch bolt is install as shown in Figure 2.

3. Install the bolt (3/8 x 4-1/2 inch) through the hitch and gear case shown in Figure 2. Do not install the nut (3/8 inch) at this time.
4. Install the drive pulley, so the hub is a 1/4 inch from the end of the drive shaft (Fig. 2). Secure pulley with a square key and 2 square head set screws (5/16 inch).

Important Key must be located under a set screw to be retained.

5. Align the belt cover with the hitch. Install the belt cover onto the 3/8 x 4-1/2 inch bolt and fasten the bolt with a nut (3/8 inch).
6. Assemble idler pulley and belt guide into lower hole of belt guard and install onto hitch through upper hole with a bolt (3/8 x 1-5/8 inch) and a lock nut (3/8 inch) (Fig. 2).

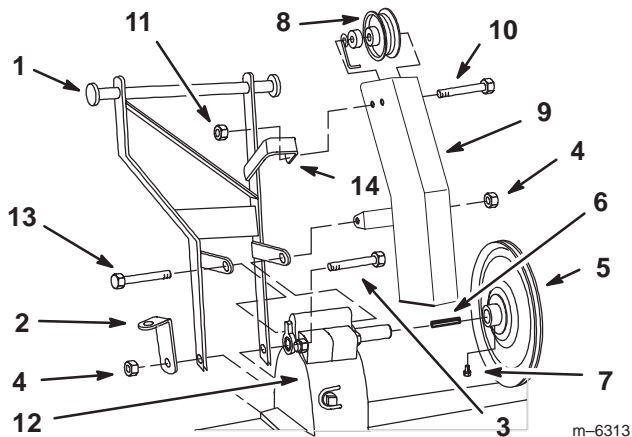

Figure 2

- | | |
|---------------------------|----------------------------|
| 1. Hitch | 8. Idler pulley |
| 2. Spring bracket | 9. Belt cover |
| 3. Bolt, 3/8 x 5-1/2 inch | 10. Bolt, 3/8 x 1-5/8 inch |
| 4. Nut, 3/8 inch | 11. Lock nut, 3/8 inch |
| 5. Drive pulley | 12. Tiller gear case |
| 6. Key | 13. Bolt, 3/8 x 4-1/2 inch |
| 7. Set screw, 5/16 inch | 14. Upper hole |

Installing the Rear Shield

1. Rotate tiller down and hook rear shield into slots at rear of tine shield. Secure with 3 cotter pins (1 inch) (Fig. 3).

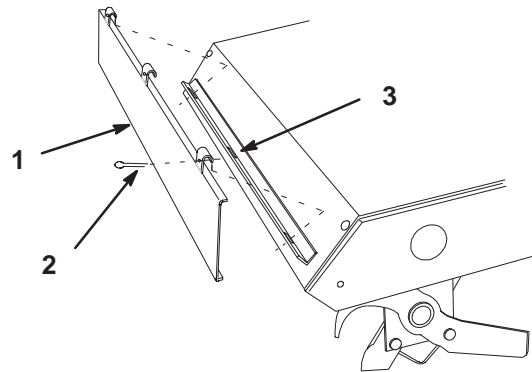

Figure 3

- | | |
|-----------------------|---------|
| 1. Rear shield | 3. Slot |
| 2. Cotter pin, 1 inch | |

2. Attach lift chain, short link end and one link short, to lift bracket. Secure lift chain with clevis, clevis pin and a cotter pin (3/4 inch) (Fig. 4).

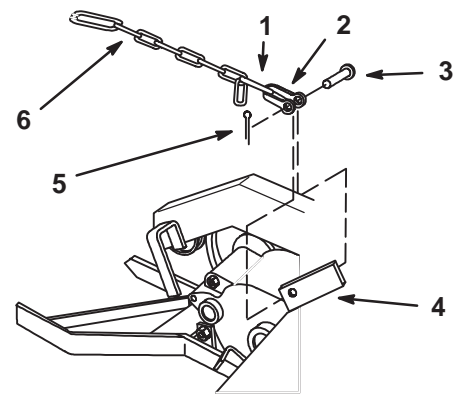

Figure 4

- | | |
|-------------------|-------------------------|
| 1. Short link end | 4. Bracket |
| 2. Clevis | 5. Cotter pin, 3/4 inch |
| 3. Clevis pin | 6. Lift chain |

Installing the Lift Cable and Lift Lever

1. Remove the carriage bolts at fender mount under the seat and attaching footrests (Fig. 5).

Note: Save all hardware for use when installing fenders.

2. Unplug seat wiring harness connector and remove wire harness from wire clip.

Note: If tractor has a 25 amp fuse clipped inside console, remove the fuse.

3. Remove the fender\seat pan from the tractor.

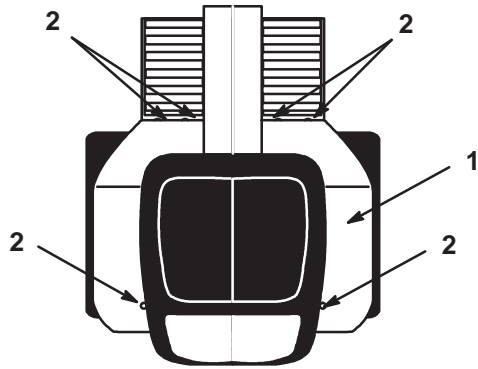

1229a

Figure 5

1. Fender\seat pan 2. Carriage bolt

4. Remove bolts and lock washers securing fuel tank bracket to the top of transmission (Fig. 6).
 5. Select proper cable tube; straight for gear drive and bent for hydrostatic drive. Secure the cable tube, fuel tank bracket and clamp with previously removed lock washers and bolts (Fig. 6 and 7).

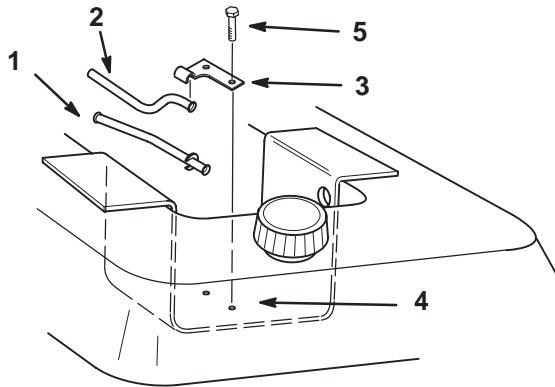

2293

Figure 6

1. Cable tube—gear drive 3. Clamp
 2. Cable tube—hydrostatic drive 4. Bracket
 5. Bolt

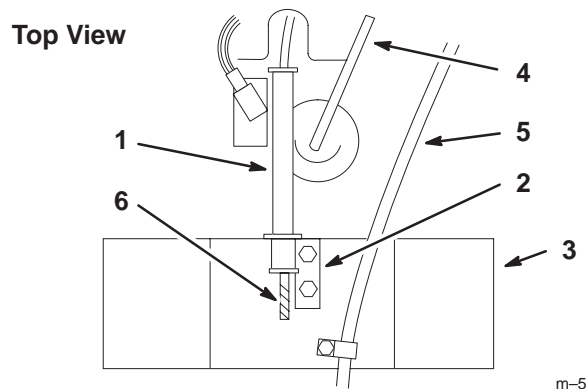

m-5670

Figure 7

1. Cable tube—gear drive 4. Gear shift
 2. Clamp 5. Fuel line
 3. Bracket 6. Cable

6. Slide a shim washer and bushing onto both ends of lift lever rod (Fig. 8).

Important Check that bushings slide easily onto rod ends and into frame. Remove paint if necessary.

7. Position lift lever into frame and slide bushings and shim washers outward into frame holes. Secure in position with E-rings (Fig. 8).

Important Lift lever must not have excessive end play (more than 0.015 inch). Use extra shim washers (0.015 and 0.020 inch thick) to reduce end play.

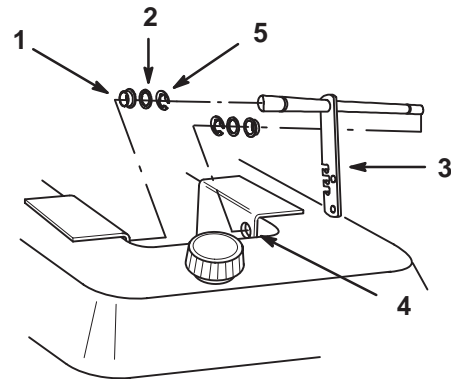

2291

Figure 8

1. Bushing 3. Lift lever
 2. Shim Washer (as required) 4. Frame hole
 5. E-ring

Note: If the tractor has a 25 amp fuse clipped inside console, install the fuse.

8. Slide ball end of attachment lift cable through cable tube from the rear of machine.

9. Select correct clevis as follows:

- 2 inch long clevis: for 8-speed gear drive and hydrostatic models with oil filter on right side.
- 3-1/8 inch long clevis: for hydrostatic models with oil filter facing rear.

10. Lower attachment lift and place cable, ball end, into slot in clevis (Fig. 9). Attach clevis to hole in attachment lift and secure with clevis pin and a cotter pin (1 inch) (Fig. 9).

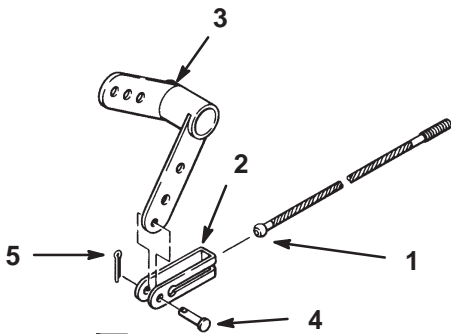

Figure 9

- | | |
|--------------------------------|-----------------------|
| 1. Lift cable knob | 4. Clevis pin |
| 2. Clevis (select proper size) | 5. Cotter pin, 1 inch |
| 3. Attachment lift | |

11. Thread trunnion 1 inch (26 mm) onto the threaded end of lift cable. Insert trunnion into lower hole of lift lever. Secure with a washer (3/8 inch) and hairpin cotter (Fig. 10).

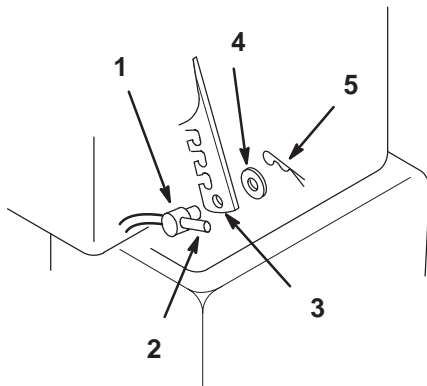

Figure 10

- | | |
|-----------------------------|---------------------|
| 1. Trunnion | 4. Washer, 3/8 inch |
| 2. Lift cable threaded end | 5. Hairpin cotter |
| 3. Lower hole in lift lever | |

12. Install fenders and seat with previously removed hardware.

13. Plug the wiring harness connector into the seat and insert wire harness into wire clip.

Removing the Drawbar

1. Remove snap ring from pin and slide from drawbar and spacers. Remove hitch from tractor (Fig. 11).

Note: Save all hardware for use when re-installing hitch.

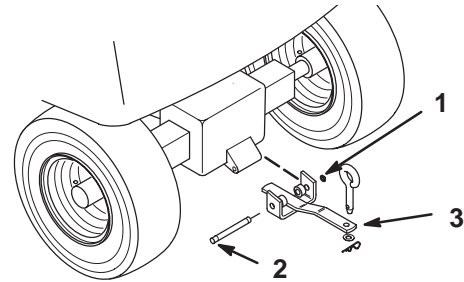

Figure 11

- | | |
|--------------|------------|
| 1. Snap ring | 3. Drawbar |
| 2. Pin | 4. Spacer |

Assembling the Mounting Plate

1. Install latch levers to mounting plate with carriage bolts (3/8 x 1 inch), washers (3/8 inch) and lock nuts (3/8 inch) (Fig. 12).

Note: Tighten nuts so latch levers move, but hold in position for ease of tiller mounting to tractor.

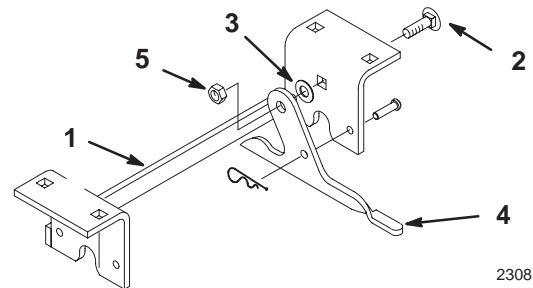

Figure 12

- | | |
|--------------------------------|-----------------------|
| 1. Mounting plate | 4. Latch lever |
| 2. Carriage bolt, 3/8 x 1 inch | 5. Lock nut, 3/8 inch |
| 3. Washer, 3/8 inch | |

Installing the Mounting Plate

1. Center hitch on axle housing and install with 4 carriage bolts (3/8 x 3 inch), left side angle plate (with hole rearward), right side strap and lock nut (3/8 inch) as shown in figure 13.

Note: For hydrostatic models with oil filter facing rear, locate hitch 3-1/4 inch (8.3 cm) from right side of center housing.

Note: For 8-speed gear drive and hydrostatic models with oil filter on right side tighten hitch mounting by installing angle spacers positioned along top and rear of axle.

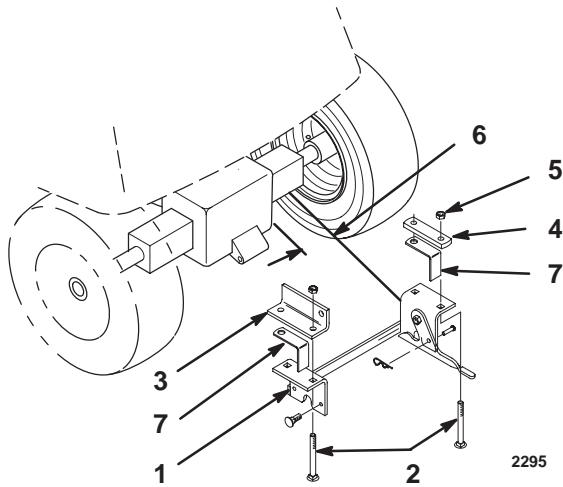

Figure 13

- | | |
|-------------------------------|---------------------------------|
| 1. Mounting plate | 5. Lock nut, 3/8 inch |
| 2. Carriage bolt, 3/8 x 3 in. | 6. 3-1/4 inch (8.3 cm) location |
| 3. Angle plate-left side | 7. Angle spacer-if required |
| 4. Strap-right side | |

Installing the Idler Arm Pulley Assembly

1. Check mounting location of idler arm in hole of idler bracket (Fig. 14). Correct location is as follows:
 - Front hole for 400 & 500 Series Twin cylinder tractors and all Single cylinder tractors.
 - Rear hole for C & GT Series Twin cylinder tractors.
2. If necessary, remove the lock nut (3/8 inch) (Fig. 14) and change idler arm hole location. Secure idler arm with same lock nut.

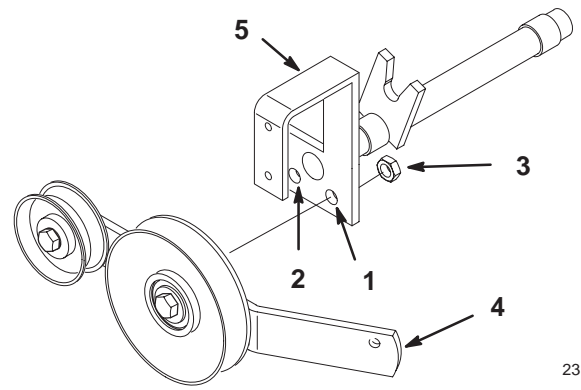

Figure 14

- | | |
|-----------------------|-----------------------|
| 1. Front hole | 4. Idler arm assembly |
| 2. Rear hole | 5. Idler bracket |
| 3. Lock nut, 3/8 inch | |

Installing the Tiller to the Tractor

1. Park the machine on a level surface, disengage the power take off (PTO), set the parking brake, and turn the ignition key to off. Remove the key.
2. Position tiller behind and under rear tractor hitch with idler pulley bracket above right latch lever. Lift latch levers and install mounting rod. Center tiller between hitch latches (Fig. 15).
3. With latch levers closed, secure with clevis pins and hairpin cotters (Fig. 15).

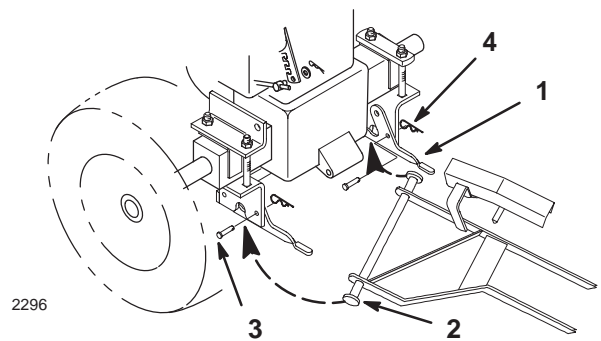

Figure 15

- | | |
|-----------------|-------------------|
| 1. Latch lever | 3. Clevis pin |
| 2. Mounting rod | 4. Hairpin cotter |

4. Set Dial-a-Height to the Mounting Position, and lower attachment lift all the way. Refer to Adjusting Dial-a-Height on page 13.
5. Remove trunnion and slide long link of lift chain under attachment lift arm and hook into lower notch (Fig. 16). Install trunnion into bottom hole of lift lever (Fig. 10).
6. Raise attachment lift lever to the transport position and place a block under tiller gear case.
7. Hook lift assist spring through left hitch angle mounting plate and eye bolt. Secure eye bolt through bracket with a lock nut (3/8 inch) (Fig. 16). Adjust lock nut so there is light spring tension in the fully raised position.

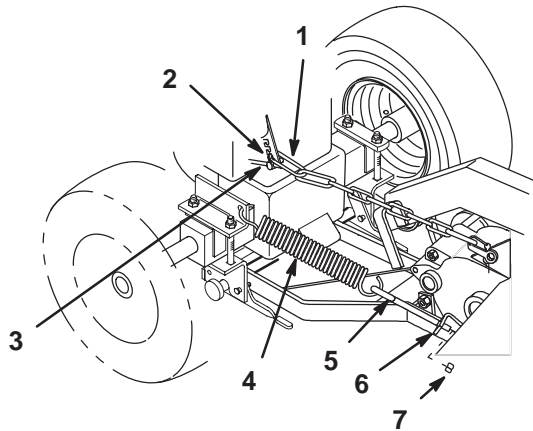

Figure 16

- | | |
|-----------------------|-----------------------|
| 1. Long link | 5. Eye bolt |
| 2. Notch | 6. Bracket |
| 3. Trunnion | 7. Lock nut, 3/8 inch |
| 4. Lift assist spring | |

8. Open mid-mount hitch and insert rod of idler bracket (Fig. 17).
9. Slide spring onto bolt (3/8 x 1-3/4 inch) and thread on first lock nut (3/8 inch) (Fig. 17). Place bolt through hole in frame, just in front of mid-mount hitch, and secure with a lock nut (3/8 inch) (Fig. 17).
10. Hook spring into hole in idler arm assembly.

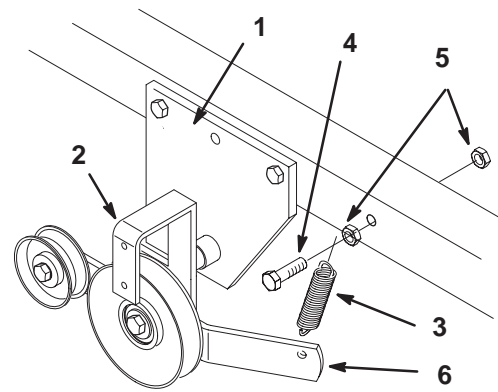

Figure 17

- | | |
|--------------------|---------------------------|
| 1. Mid-mount hitch | 4. Bolt, 3/8 x 1-1/4 inch |
| 2. Idler bracket | 5. Lock nut, 3/8 inch |
| 3. Spring | 6. Idler arm assembly |

11. Install belt onto pulleys. See Replacing the Power Take Off (PTO) Belt on page 16.

Operation

Note: Determine the left and right sides of the machine from the normal operating position.

⚠
Danger
⚠

Rotating tines can cause injury to hands, feet or other body parts.

- Keep away from the rotating tines while operating the tiller.
- Keep your hands, feet, and any other part of your body or clothing away from rotating parts.
- Before adjusting, cleaning, repairing and inspecting the tiller, shut off the engine and wait for all moving parts to stop. Move the power take off (PTO) to the *off* position and turn the engine off. Remove the key.

⚠
Warning
⚠

Shock or explosion may occur if the tiller contacts buried power, gas, and/or telephone lines.

- Have the property or area to be tilled marked for buried lines.



Warning



Tines can throw dirt, debris, and small rocks. The operator or bystander could be injured by flying debris.

- Run the tiller so that debris is thrown away from the traction unit.
- Keep all bystanders away from the work area.

Operating the Power Take Off (PTO) on 2001 and Newer Models

The power take off (PTO) switch engages and disengages power to the electric clutch.

The PTO light, in the Indicator Module, will be on when the ignition key is in run or lights position and the power take off (PTO) is engaged. When this light is on it is a reminder the starter will not crank and to turn the off PTO before getting off the tractor.

Engaging the Power Take Off (PTO)

1. Move throttle to fast position.
2. Pull the power take off (PTO) to the **on** position (Fig. 18).

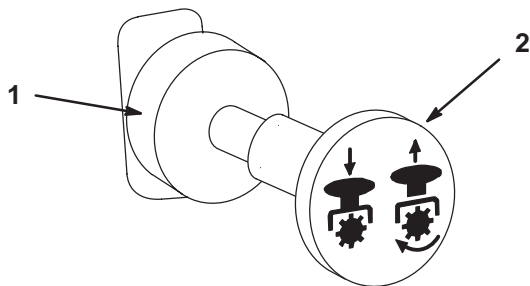

m-4201

Figure 18

1. PTO—Off
2. PTO—On

Disengaging the Power Take Off (PTO)

1. Push the power take off (PTO) to the **off** position (Fig. 18).

Operating the Power Take Off (PTO) on 2000 and Older Models

The power take off (PTO) engages and disengages power to the clutch.

Engaging the Power Take Off (PTO)

1. Depress the brake and/or clutch pedal(s) to stop the machine.
2. Move the power take off (PTO) to **on** (Fig. 19).

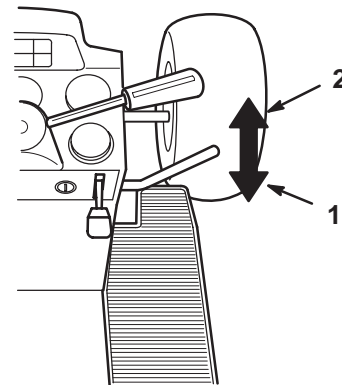

2318

Figure 19

1. Off—disengaged
2. On—engaged

Disengaging the Power Take Off (PTO)

1. Depress the brake and/or clutch pedal(s) to stop the machine.
2. Move the power take off (PTO) to **off** (Fig.19).

Operating the Attachment Lift Lever

The attachment lift lever (Fig. 20) is used to raise and lower various attachments.

Raising an Attachment

1. Depress the clutch and brake pedals to stop the machine.
2. Pull attachment lift lever rearward until latch locks. In this position the lift will hold the attachment in the up, or raised position.

Lowering an Attachment

1. Depress the clutch and brake pedals to stop the machine.

2. Pull attachment lift lever rearward, to release lift pressure, and push the button on top to release the latch. Move lift lever forward to lower attachment.

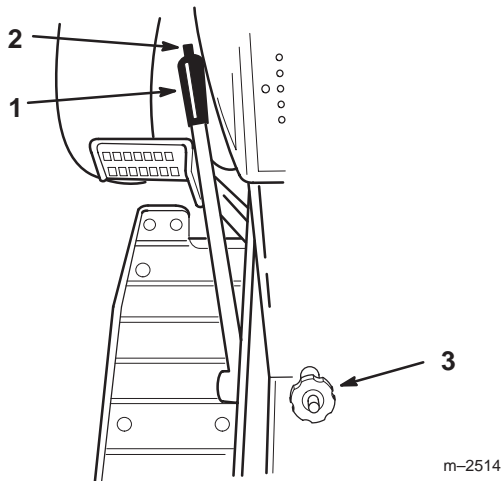

Figure 20

1. Lift lever
2. Button
3. Dial-A-Height

Operating the Attachment Power Lift

The attachment power lift (Fig. 21) is used to raise and lower attachments.

Raising Attachments

1. Start the engine, refer to; Starting and Stopping the Engine; in tractor Operator's Manual.
2. Pull the lift lever in the **up** direction to raise the attachment lift (Fig. 21). This will lift and hold the attachment in the up, or raised position.

Lowering Attachments

1. Start the engine, refer to; Starting and Stopping the Engine; in tractor Operator's Manual.
2. Push the lift lever in the **down** direction to lower the attachment lift (Fig. 21).

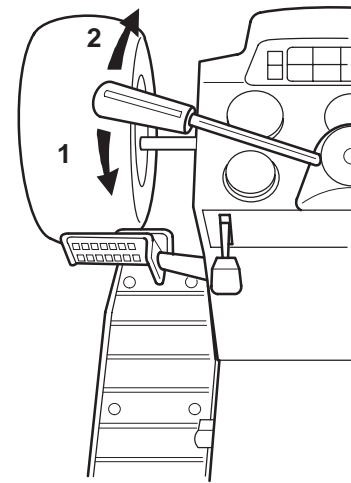

Figure 21

1. Lift lever—UP
2. Lift lever—DOWN

Adjusting Dial-A-Height

The Dial-A-Height control (Figs. 20) is used to limit the downward travel of the attachment, on gear drive tractors only. The Dial-A-Height knob is rotated to change the location of this stop, up or down.

1. Raise the attachment lift lever: Refer to Raising Attachments. In the raised position the Dial-A-Height knob (Fig. 20) can be rotated to change the stop location. Turn clockwise to raise and counterclockwise to lower the height of the attachment.
2. The Dial-A-Height indicator (Fig. 20) will show the change, high to low, in attachment lift height as adjustment is made.

Adjusting Lift Chain



Danger



Rotating tines can cause injury to hands, feet or other body parts.

- **Keep away from the rotating tines while operating the tiller.**
- **Keep your hands, feet, and any other part of your body or clothing away from rotating parts.**
- **Before adjusting, cleaning, repairing and inspecting the tiller, shut off the engine and wait for all moving parts to stop. Move the power take off (PTO) to the *off* position and turn the engine off. Remove the key.**

Changing the lift chain link location at the lift arm notch, affects maximum tilling depth, transport lift height and lift effort. The location can be changed at the lever (Fig. 22).

1. For maximum tilling depth and transport lift height locate link of lift chain in the lowest notch of lift lever (Fig. 22). This position will have the greatest lift effort.
2. For minimum tilling depth and reduced lift height, locate the link of lift chain in the upper clevis notch of lift lever (Fig. 22). This position will have lowest lift effort.
3. For variations of less than the three notches in the lift lever, disconnect the lift cable from the lift arm and rotate the trunnion (Fig. 22) Turning clockwise increases lift height and reduces tilling depth and counter clockwise reduces lift height and increases tilling depth.

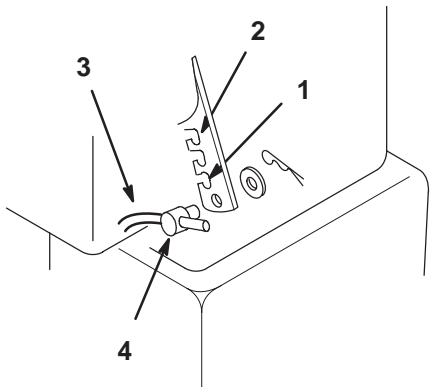

Figure 22

- | | |
|------------------|---------------|
| 1. Lowest notch | 3. Lift cable |
| 2. Highest notch | 4. Trunnion |

2309

Removing the Tiller

Note: Save all hardware, washers and hairpin cotters for re-use when installing tiller.

1. Park the machine on a level surface, disengage the power take off (PTO), set the parking brake, and turn the ignition key to off. Remove the key.
2. Turn the Dial-a-Height knob counterclockwise, all the way and lower the attachment lift lever to the mounting position; refer to Lowering Attachment.
3. Remove the belt guard (Fig. 30).
4. Pull on idler arm spring to relieve belt tension and remove tiller drive belt from tiller pulley and slide belt out of groove (Fig. 23).
5. Remove belt from the clutch pulley. Refer to Replacing the Power Take Off (PTO) Belt on page 16.
6. Open mid-mount hitch and remove idler bracket assembly (Fig. 23). Unhook spring from idler arm (Fig. 23).

7. Remove second lock nut from spring mounting bolt and remove (Fig. 23).

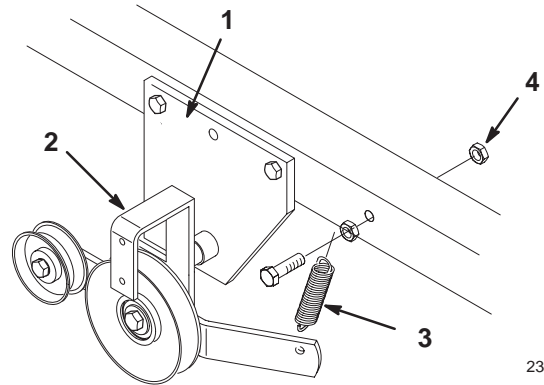

2311

Figure 23

- | | |
|---------------------------|-------------|
| 1. Mid-mount hitch | 3. Spring |
| 2. Idler bracket assembly | 4. Lock nut |

8. Raise attachment lift to the transport position and place a block under tiller gear case.
9. Loosen lock nut on eye bolt and unhook lift assist spring from tractor (Fig. 24).
10. Turn the Dial-a-Height knob counterclockwise, all the way, remove block and lower the attachment lift lever to the mounting position; refer to Lowering Attachment.
11. Remove hairpin cotter and trunnion from lift arm and unhook long link of lift chain from lift arm (Fig. 24). Install trunnion and hairpin cotter (Fig. 24).

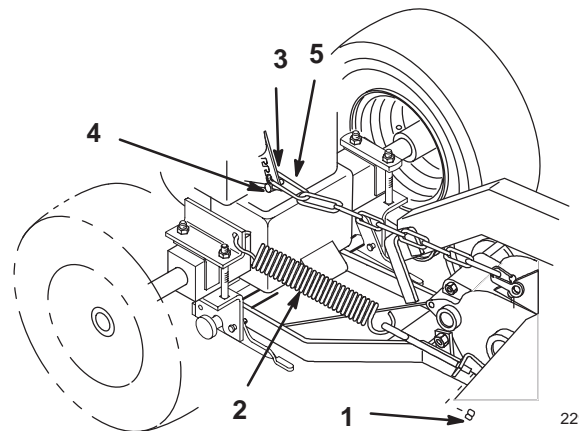

2297

Figure 24

- | | |
|-----------------------|--------------|
| 1. Lock nut | 4. Trunnion |
| 2. Lift assist spring | 5. Long link |
| 3. Hairpin cotter | |

12. Remove hairpin cotters and clevis pins from latch levers (Fig. 25). Open latch levers and remove mounting rod.

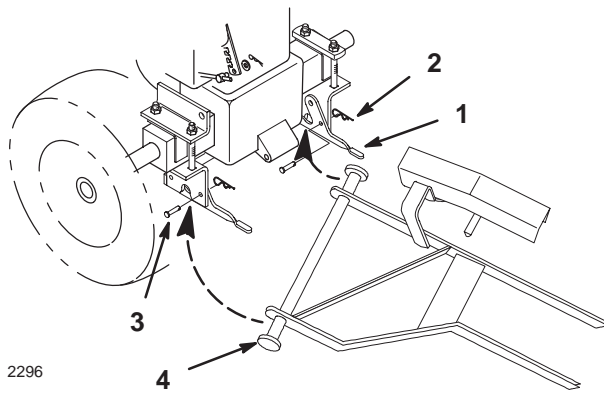

Figure 25

- | | |
|-------------------|-----------------|
| 1. Hairpin cotter | 3. Latch lever |
| 2. Clevis pin | 4. Mounting rod |

Note: Save all hardware, washers and hairpin cottes for reuse when installing tiller.

Tips for Tilling

Clean area of trash, branches and rocks before tilling to prevent equipment damage.

Maintenance

Note: Determine the left and right sides of the machine from the normal operating position.

Recommended Maintenance Schedule

Maintenance Service Interval	Maintenance Procedure
25 Hours	<ul style="list-style-type: none"> • Gear case Oil—check
Fall Service	<ul style="list-style-type: none"> • Gear case Oil—check • Belts—check for wear/cracks
Storage Service	<ul style="list-style-type: none"> • Gear case Oil—check • Belts—check for wear/cracks • Chipped Surfaces—paint



Caution



If you leave the key in the ignition switch, someone could accidentally start the engine and seriously injure you or other bystanders.

Remove the key from the ignition and disconnect the wire from the spark plug(s) before you do any maintenance. Set the wire aside so that it does not accidentally contact the spark plug.

Greasing and Lubrication

Service Interval/Specification

Check the gear lube level in the gear case after every 25 operating hours or once a year, whichever occurs first. Gear lube changes are not required.

Gear lube type: SAE 90-140 API service GL-4 or GL-5.

Refill capacity: 32 oz. (946 ml)

Checking Gear Lube

1. Position the tractor and tiller on a level surface and lower the attachment lift so that the tiller tines are on the ground. Set the parking brake and turn the ignition key to off. Remove the key.
2. Clean the area around the lower pipe plug (Fig. 26).
3. Remove the pipe plug carefully because the oil level may be above the level of the pipe plug.
4. If gear lube runs from the case when the plug is removed, the lube in the case is sufficient. Oil may be added as necessary.

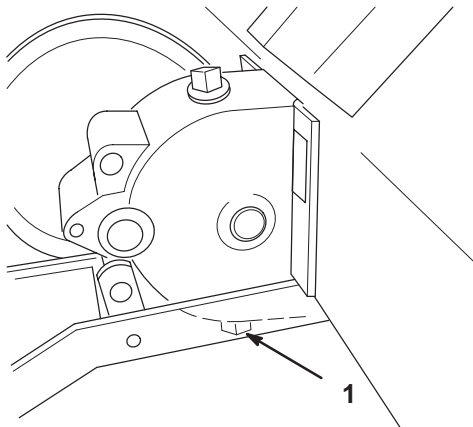

Figure 26

Left side of tiller shown in operating position

1. Pipe plug (hidden)

m-3497

Adjusting Drive Belt Tension

The drive belt is spring loaded and needs only periodic adjustment, to maintain proper spring tension.

Checking Drive Belt Tension

1. Disengage the power take off (PTO), set the parking brake, and turn the ignition key to off. Remove the key.
2. As the drive belt wears, and the tiller is raised and lowered, the spring loaded idler arm moves (Fig. 27).
3. Lower the tiller and observe the spring loaded idler arm movement as you push on the belt. The idler arm spring must be under tension. If it is not under tension, replace the drive belt.

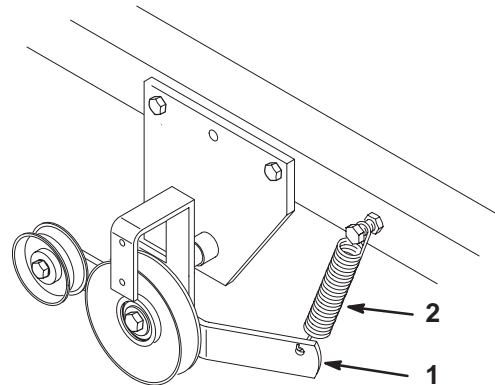

2319

Figure 27

1. Spring loaded idler arm
2. Spring

Replacing the Power Take Off (PTO) Belt

Replacing the PTO Belt on 2001 and Newer Models

The following instructions are for 2001 and newer models only.

1. Unplug the clutch connector (Fig. 28).
2. Pull the PTO stop out of the clutch (Fig. 28).
3. Rotate the clutch to allow space between the belt guide and the clutch. This will allow the belt to be installed onto the pulley (Fig. 28).
4. Replace the belt and install new belt into the inside pulley (Fig. 28).

Important Install belt in the inside pulley groove for the mower.

5. Install the PTO stop back into the clutch (Fig. 28).

6. Install the clutch connector (Fig. 28).

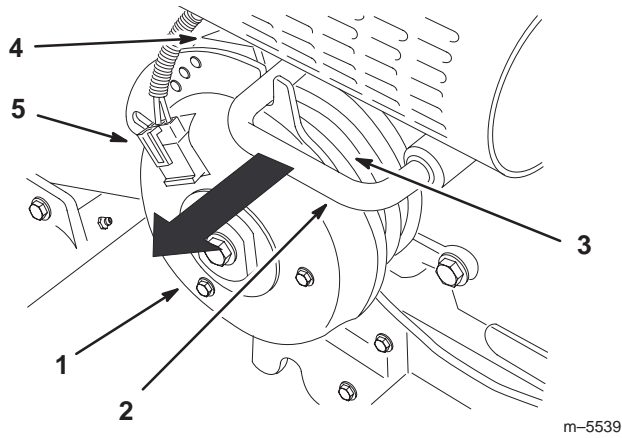

Figure 28

- | | |
|-----------------------|---------------------|
| 1. PTO clutch | 4. Belt guide |
| 2. PTO stop | 5. Clutch connector |
| 3. Inside belt groove | |

7. Route belt around and mid-mount idler pulleys, below frame and behind right rear tire (Fig. 29).

8. Pull on idler arm spring to relieve tension and route belt around tiller drive pulley, under tiller idler and inside belt guide (Fig. 29).

9. Check that belt is properly routed around all pulleys and belt guide (Fig. 29).

Important Belt must be properly routed behind belt guide to prevent jumping off and premature failure (Fig. 30).

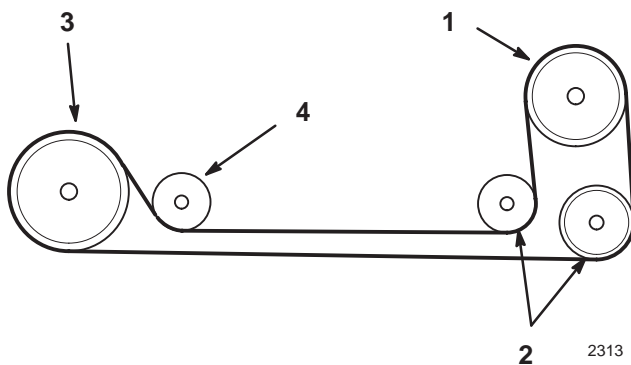

Figure 29

- | | |
|---|------------------|
| 1. Inner groove of (PTO) power take off, clutch | 3. Tiller pulley |
| 2. Mid-mount idler pulleys | 4. Tiller idler |

10. Install belt guard to mid-mount bracket with 2 self tapping bolts (1/4 x 1/2 inch) (Fig. 30).

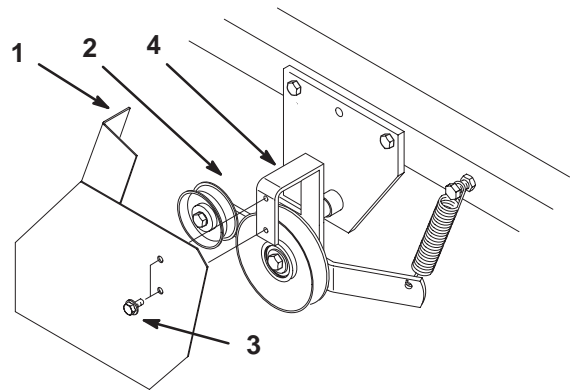

Figure 30

- | | |
|------------------|-------------------------|
| 1. Belt guard | 3. Bolt, 1/4 x 1/2 inch |
| 2. Idler bracket | 4. Belt guide |

Replacing the PTO Belt on 2000 and Older Models

The following instructions are for 2000 and Older Models only.

1. Unlatch and remove locking clevis pin that secures yoke assembly to clutch shaft. Pivot yoke out and forward to remove from clutch shaft and engagement plate (Fig. 31).
2. Replace belt in inside pulley groove (Fig. 31).
3. Assemble yoke and engagement plate and attach locking clevis pin, trunnion and hairpin cotters to secure (Fig. 31).

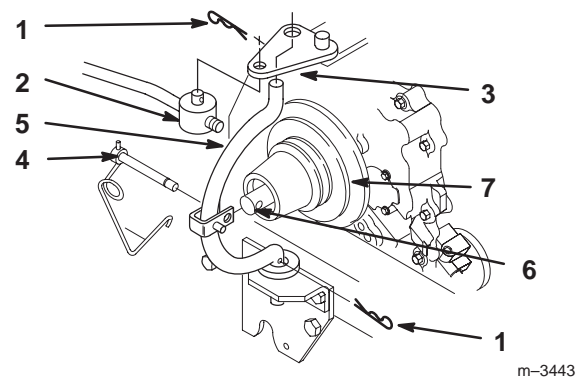

Figure 31

- | | |
|-----------------------|------------------|
| 1. Hairpin cotter | 5. Yoke |
| 2. Trunnion | 6. Clutch shaft |
| 3. Engagement plate | 7. Inside groove |
| 4. Locking clevis pin | |

4. Assemble yoke and engagement plate and attach clevis pin, trunnion and hairpin cotter to secure (Fig. 31).

5. Route belt around and mid-mount idler pulleys, below frame and behind right rear tire (Fig. 32).

6. Pull on idler arm spring to relieve tension and route belt around tiller drive pulley, under tiller idler and inside belt guide (Fig. 32).
7. Check that belt is properly routed around all pulleys and belt guide (Fig. 32).

Important Belt must be properly routed behind belt guide to prevent jumping off and premature failure.

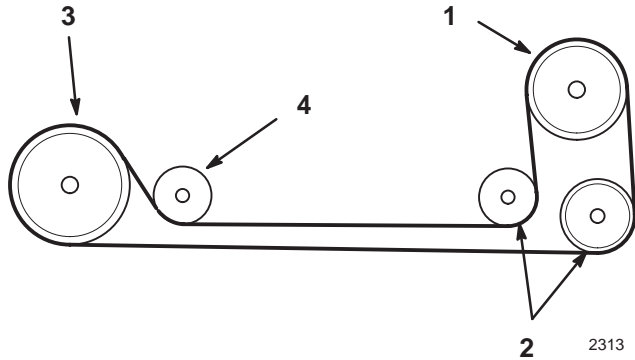

Figure 32

- | | |
|--|------------------|
| 1. Inner groove of (PTO)
power take off, clutch | 3. Tiller pulley |
| 2. Mid-mount idler pulleys | 4. Tiller idler |

8. Install belt guard to mid-mount bracket with 2 self tapping bolts (1/4 x 1/2 inch) (Fig. 33).

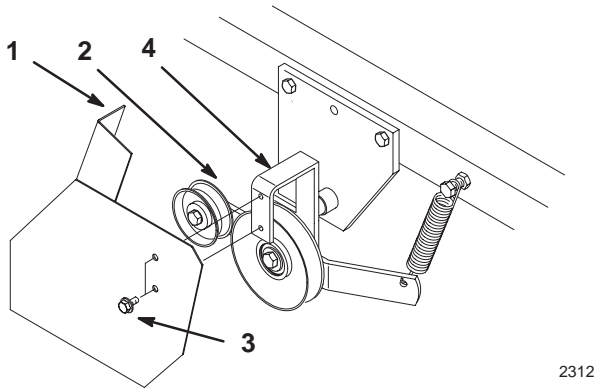

Figure 33

- | | |
|------------------|-------------------------|
| 1. Belt guard | 3. Bolt, 1/4 x 1/2 inch |
| 2. Idler bracket | 4. Belt guide |

Storage

1. Before long term storage wash the machine with mild detergent and water to remove dirt and grime from the entire machine.
2. Check the condition of the drive belt.
3. Check gearcase lubrication level; refer to Greasing and Lubrication, page 16.
4. Check and tighten all bolts, nuts, and screws. Repair or replace any part that is damaged or defective.
5. Paint all scratched or bare metal surfaces. Paint is available from your Authorized Service Dealer.
6. Store the machine in a clean, dry garage or storage area. Cover the machine to protect it and keep it clean.



Consumer
Riding
Products

The Toro Total Coverage Guarantee

A Two-Year Full Warranty
(Limited Warranty for Commercial Use)

Conditions and Products Covered

The Toro Company and its affiliate, Toro Warranty Company, pursuant to an agreement between them, jointly promise to repair any Toro Product used for normal residential purposes* if defective in materials or workmanship. The following time periods apply from the date of purchase:

<u>Products</u>	<u>Warranty Period</u>
• All Products and Attachments	2 year full warranty
• 300, 400, and 5xi Series Tractors:	
Frame	5 year full warranty
Front Axle	5 year full warranty
Drive Shaft (5xi Series Only)	5 year full warranty
• All Batteries	1 year full warranty

This warranty covers both the cost of parts and labor, and transportation within a fifteen mile radius of the servicing dealer.

This warranty applies to all consumer riding products and their attachments.

* Normal residential purposes means use of the product on the same lot as your home. Use at more than one location is considered commercial use, and the commercial use warranty would apply.

Limited Warranty for Commercial Use

Toro Consumer Products and attachments used for commercial, institutional, or rental use are warranted against defects in materials or workmanship for the following time periods from the date of purchase:

<u>Products</u>	<u>Warranty Period</u>
• 300, 400, and 5xi Series Tractors:	
Liquid Cooled Gas Engines	1 year limited warranty
Air Cooled Gas and Diesel Engines	2 year limited warranty
All other items	1 year limited warranty
• TimeCutter Models	30 day limited warranty
• All other Riding Products	90 day limited warranty

Instructions for Obtaining Warranty Service

If you think that your Toro Product contains a defect in materials or workmanship, follow this procedure:

1. Contact any Toro Authorized or Master Service Dealer to arrange service at their dealership. To locate a dealer convenient to you, refer to the Yellow Pages of your telephone directory (look under "Lawn Mowers") or access our website at www.Toro.com. U.S. Customers may also call 800-421-9684 to use our 24-hour Toro dealer locator system.
2. Bring the product and your proof of purchase (sales receipt) to the Service Dealer.

Countries Other than the United States or Canada

Customers who have purchased Toro products exported from the United States or Canada should contact their Toro Distributor (Dealer) to obtain guarantee policies for your country, province, or state. If for any reason you are dissatisfied with your Distributor's service or have difficulty obtaining guarantee information, contact the Toro importer. If all other remedies fail, you may contact us at Toro Warranty Company.

If for any reason you are dissatisfied with the Service Dealer's analysis or with the assistance provided, contact us at:

Customer Care Department, Consumer Division
Toro Warranty Company
8111 Lyndale Avenue South
Bloomington, MN 55420-1196
800-348-2424 (U.S. customers)
877-484-9255 (Canada customers)

Owner Responsibilities

You must maintain your Toro Product by following the maintenance procedures described in the operator's manual. Such routine maintenance, whether performed by a dealer or by you, is at your expense.

Items and Conditions Not Covered

There is no other express warranty except for special emission system coverage on some products. This express warranty does not cover:

- Cost of regular maintenance service or parts, such as filters, fuel, lubricants, tune-up parts, blade sharpening, brake and clutch adjustments.
- Any product or part which has been altered or misused or required replacement or repair due to normal wear, accidents, or lack of proper maintenance.
- Repairs necessary due to improper fuel, contaminants in the fuel system, or failure to properly prepare the fuel system prior to any period of non-use over three months.
- Pickup and delivery charges for distances beyond a fifteen mile radius from an Authorized Toro Service Dealer.

All repairs covered by this warranty must be performed by an Authorized Toro Service Dealer using Toro approved replacement parts.

General Conditions

Repair by an Authorized Toro Service Dealer is your sole remedy under this warranty.

Neither The Toro Company nor Toro Warranty Company is liable for indirect, incidental or consequential damages in connection with the use of the Toro Products covered by this warranty, including any cost or expense of providing substitute equipment or service during reasonable periods of malfunction or non-use pending completion of repairs under this warranty.

Some states do not allow exclusions of incidental or consequential damages, or limitations on how long an implied warranty lasts, so the above exclusions and limitations may not apply to you.

This warranty gives you specific legal rights, and you may also have other rights which vary from state to state.