



# **Groundsmaster® 120**

## **Groundsmaster Traction Unit**

**Model No. 30612—Serial No. 22000001 and Up**

**Operator's Manual**



## Warning



**The engine exhaust from this product contains chemicals known to the State of California to cause cancer, birth defects, or other reproductive harm.**

**Important** This engine is not equipped with a spark arrester muffler. It is a violation of California Public Resource Code Section 4442 to use or operate this engine on any forest-covered, brush-covered, or grass-covered land. Other states or federal areas may have similar laws.

This spark ignition system complies with Canadian ICES-002.

Ce système d'allumage par étincelle de véhicule est conforme à la norme NMB-002 du Canada.

**The enclosed Engine Owner's Manual is supplied for information regarding The U.S. Environmental Protection Agency (EPA) and the California Emission Control Regulation of emission systems, maintenance and warranty.**

**Keep this engine Owner's Manual with your unit. Should this engine Owner's Manual become damaged or illegible, replace immediately. Replacements may be ordered through the engine manufacturer.**

# Contents

	Page
Introduction .....	2
Safety .....	3
Safe Operating Practices .....	3
Toro Mower Safety .....	4
Slope Chart .....	7
Safety and Instruction Decals .....	9
Gasoline and Oil .....	12
Recommended Gasoline .....	12
Using Stabilizer/Conditioner .....	12
Filling the Fuel Tank .....	12
Checking the Engine Oil Level .....	12
Assembly .....	13
Loose Parts .....	13
Installing the Seat .....	13
Installing the Steering Wheel .....	14
Activating the Battery .....	14
Installing the Battery .....	15
Checking the Engine Oil .....	15
Checking the Hydraulic System Fluid .....	15
Operation .....	15
Think Safety First .....	15

	Page
Starting and Stopping the Engine .....	15
Operating the Power Take Off (PTO) .....	16
Driving Forward or Backward .....	16
Parking Brake .....	17
Implement Lift Lever .....	17
The Safety Interlock System .....	17
Positioning the Seat .....	18
Pushing or Towing the Machine .....	18
Maintenance .....	19
Recommended Maintenance Schedule .....	19
Servicing the Air Cleaner .....	20
Engine Oil Service .....	21
Spark Plug Service .....	22
Greasing and Lubrication .....	23
Brake Service .....	24
Replacing the Fuel Filter .....	24
Tire Pressure Service .....	25
Cleaning the Cooling System .....	25
Adjusting the Belts .....	25
Replacing the Belts .....	25
Adjusting the Lift Cylinder and Counterbalance Springs .....	26
Adjusting the Transmission Neutral .....	26
Adjusting the Electric Clutch .....	27
Checking the Hydraulic System Fluid .....	27
Changing the Hydraulic System Oil .....	28
Changing the Hydraulic Oil Filter .....	28
Adjusting the Steering .....	29
Changing the Front Axle Oil .....	29
Servicing the Battery .....	29
Servicing the Wire Harness .....	30
Waste Disposal .....	30
Transporting Machines .....	30
Hydraulic Schematic .....	31
Wiring Diagram .....	32
Cleaning and Storage .....	33
Troubleshooting .....	33
The Toro Total Coverage Guarantee .....	36

# Introduction

Read this manual carefully to learn how to operate and maintain your product properly. The information in this manual can help you and others avoid injury and product damage. Although Toro designs and produces safe products, you are responsible for operating the product properly and safely.

Whenever you need service, genuine Toro parts, or additional information, contact an Authorized Service Dealer or Toro Customer Service and have the model and

serial numbers of your product ready. Figure 1 illustrates the location of the model and serial numbers on the product.

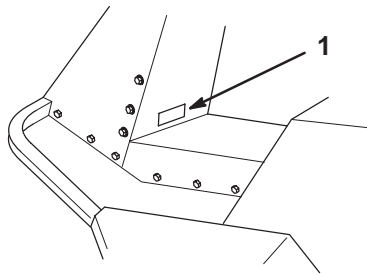

m-2196

**Figure 1**

1. Location of the model and serial numbers

Write the product model and serial numbers in the space below:

<b>Model No.</b> _____
<b>Serial No.</b> _____

This manual identifies potential hazards and has special safety messages that help you and others avoid personal injury and even death. **Danger**, **Warning**, and **Caution** are signal words used to identify the level of hazard. However, regardless of the hazard, be extremely careful.

**Danger** signals an extreme hazard that *will* cause serious injury or death if you do not follow the recommended precautions.

**Warning** signals a hazard that *may* cause serious injury or death if you do not follow the recommended precautions.

**Caution** signals a hazard that may cause minor or moderate injury if you do not follow the recommended precautions.

This manual uses two other words to highlight information.

**Important** calls attention to special mechanical information and **Note**: emphasizes general information worthy of special attention.

## Safety

**This machine meets or exceeds the B71.4 1999 specifications of the American National Standards Institute, in effect at time of production.**

**Note:** The addition of attachments made by other manufacturers that do not meet American National Standards Institute certification will cause noncompliance of this machine.

**Improper use or maintenance by the operator or owner can result in injury. To reduce the potential for injury, comply with these safety instructions and always pay attention to the safety alert symbol, which means CAUTION, WARNING, or DANGER—“personal safety instruction.” Failure to comply with the instruction may result in personal injury or death.**

## Safe Operating Practices

The following instructions are from ANSI standard B71.4—1999.

### Training

- Read the Operator’s Manual and other training material. If the operator(s) or mechanic(s) can not read English it is the owner’s responsibility to explain this material to them.
- Become familiar with the safe operation of the equipment, operator controls, and safety signs.
- All operators and mechanics should be trained. The owner is responsible for training the users.
- Never let children or untrained people operate or service the equipment. Local regulations may restrict the age of the operator.
- The owner/user can prevent and is responsible for accidents or injuries occurring to himself or herself, other people or property.

### Preparation

- Evaluate the terrain to determine what accessories and attachments are needed to properly and safely perform the job. Only use accessories and attachments approved by the manufacturer.
- Wear appropriate clothing including hard hat, safety glasses and ear protection. Long hair, loose clothing or jewelry may get tangled in moving parts.
- Inspect the area where the equipment is to be used and remove all objects such as rocks, toys and wire which can be thrown by the machine.
- Use extra care when handling gasoline and other fuels. They are flammable and vapors are explosive.
  - Use only an approved container
  - Never remove gas cap or add fuel with engine running. Allow engine to cool before refueling. Do not smoke.
  - Never refuel or drain the machine indoors.

- Check that operator's presence controls, safety switches and shields are attached and functioning properly. Do not operate unless they are functioning properly.

## Operation

- Never run an engine in an enclosed area.
- Only operate in good light, keeping away from holes and hidden hazards.
- Be sure all drives are in neutral and parking brake is engaged before starting engine. Only start engine from the operator's position. Use seat belts if provided.
- Slow down and use extra care on hillsides. Be sure to travel in the recommended direction on hillsides. Turf conditions can affect the machine's stability. Use caution while operating near drop-offs.
- Slow down and use caution when making turns and when changing directions on slopes.
- Never raise deck with the blades running.
- Never operate with the PTO shield, or other guards not securely in place. Be sure all interlocks are attached, adjusted properly, and functioning properly.
- Never operate with the discharge deflector raised, removed or altered, unless using a grass catcher.
- Do not change the engine governor setting or overspeed the engine.
- Stop on level ground, lower implements, disengage drives, engage parking brake (if provided), shut off engine before leaving the operator's position for any reason including emptying the catchers or unclogging the chute.
- Stop equipment and inspect blades after striking objects or if an abnormal vibration occurs. Make necessary repairs before resuming operations.
- Keep hands and feet away from the cutting units.
- Look behind and down before backing up to be sure of a clear path.
- Never carry passengers and keep pets and bystanders away.
- Slow down and use caution when making turns and crossing roads and sidewalks. Stop blades if not mowing.
- Be aware of the mower discharge direction and do not point it at anyone.
- Do not operate the mower under the influence of alcohol or drugs
- Use care when loading or unloading the machine into a trailer or truck

- Use care when approaching blind corners, shrubs, trees, or other objects that may obscure vision.

## Maintenance and storage

- Disengage drives, lower implement, set parking brake, stop engine and remove key or disconnect spark plug wire. Wait for all movement to stop before adjusting, cleaning or repairing.
- Clean grass and debris from cutting units, drives, mufflers, and engine to help prevent fires. Clean up oil or fuel spillage.
- Let engine cool before storing and do not store near flame.
- Shut off fuel while storing or transporting. Do not store fuel near flames or drain indoors.
- Park machine on level ground. Never allow untrained personnel to service machine.
- Use jack stands to support components when required.
- Carefully release pressure from components with stored energy.
- Disconnect battery or remove spark plug wire before making any repairs. Disconnect the negative terminal first and the positive last. Reconnect positive first and negative last.
- Use care when checking blades. Wrap the blade(s) or wear gloves, and use caution when servicing them. Only replace blades. Never straighten or weld them.
- Keep hands and feet away from moving parts. If possible, do not make adjustments with the engine running.
- Charge batteries in an open well ventilated area, away from spark and flames. Unplug charger before connecting or disconnecting from battery. Wear protective clothing and use insulated tools.
- Keep all parts in good working condition and all hardware tightened. Replace all worn or damaged decals.

## Toro Mower Safety

The following list contains safety information specific to Toro products or other safety information that you must know that is not included in the ANSI standards.

This product is capable of amputating hands and feet and throwing objects. Always follow all safety instructions to avoid serious injury or death.

This product is designed for cutting and recycling grass or, when equipped with a grass bagger, for catching cut grass. Any use for purposes other than these could prove dangerous to user and bystanders.

## General Operation

- Allow only responsible adults who are familiar with the instructions to operate the machine.
- Be sure the area is clear of other people before mowing. Stop the machine if anyone enters the area.
- Do not mow in reverse unless absolutely necessary. Always look down and behind before and while backing.
- Be aware of the mower discharge direction and do not point it at anyone. Do not operate the mower without either the entire grass catcher or the guard in place.
- Slow down before turning. Sharp turns on any terrain may cause loss of control.
- Turn off blades when not mowing.
- Keep hands, feet, hair and loose clothing away from attachment discharge area, underside of mower and any moving parts while engine is running.
- Stop the engine before removing the grass catcher or unclogging the chute.
- Mow only in daylight or good artificial light.
- Watch for traffic when operating near or crossing roadways.
- Do not touch equipment or attachment parts which may be hot from operation. Allow to cool before attempting to maintain, adjust or service.
- Before operating a machine with ROPS (roll over protection) be certain the seat belts are attached to prevent the seat from pivoting forward.
- Use only Toro-approved attachments. Warranty may be voided if used with unapproved attachments.

## Slope Operation

Slopes and ramps are a major factor related to loss-of-control and tip-over accidents, which can result in severe injury or death. All slopes and ramps require extra caution. If you cannot back up the slope or if you feel uneasy on it, do not mow it.

### DO

- If a steep slope must be ascended, back up the hill, and drive forward down the hill, keeping the machine in gear.
- Remove obstacles such as rocks, tree limbs, etc. from the mowing area. Watch for holes, ruts or bumps, as uneven terrain could overturn the machine. Tall grass can hide obstacles.
- Use slow speed so that you will not have to stop while on the slope.

- Follow the manufacturer's recommendations for wheel weights or counterweights to improve stability.
- Use extra care with grass catchers or other attachments. These can change the stability of the machine.
- Keep all movement on slopes slow and gradual. Do not make sudden changes in speed or direction.
- Avoid starting or stopping on a slope. If tires lose traction, disengage the blades and proceed slowly straight down the slope.
- When operating machine on slopes, banks or near drop offs, always have ROPS (roll over protection) installed.
- When operating a machine with ROPS (roll over protection) always use seat belt.
- Be certain that the seat belt can be released quickly if the machine is driven or rolls into ponds or water.
- Check carefully for overhead clearances (i.e. branches, doorways, electrical wires) before driving under any objects and do not contact them.

### DO NOT

- Do not mow slopes exceeding 15 degrees.
- Avoid turning on slopes. If you must turn, turn slowly and gradually downhill, if possible.
- Do not mow near drop-offs, ditches, or embankments. The machine could suddenly turn over if a wheel goes over the edge of a cliff or ditch, or if an edge caves in.
- Do not mow on wet grass. Reduced traction could cause sliding.
- Do not try to stabilize the machine by putting your foot on the ground.
- Do not use a grass catcher on steep slopes. Heavy grass bags could cause loss of control or overturn the machine.

## Service

- Never store the machine or fuel container inside where there is an open flame, such as near a water heater or furnace.
- Keep nuts and bolts tight, especially the blade attachment bolts. Keep equipment in good condition.
- Never tamper with safety devices. Check safety systems for proper operation before each use.
- Use only genuine replacement parts to ensure that original standards are maintained.
- Check brake operation frequently. Adjust and service as required.

- Battery acid is poisonous and can cause burns. Avoid contact with skin, eyes and clothing. Protect your face, eyes and clothing when working with a battery.
- Battery gases can explode. Keep cigarettes, sparks and flames away from battery.
- Hydraulic fluid escaping under pressure can penetrate the skin and cause injury. Use cardboard or paper to find hydraulic leaks. Never use your hands.

# Slope Chart

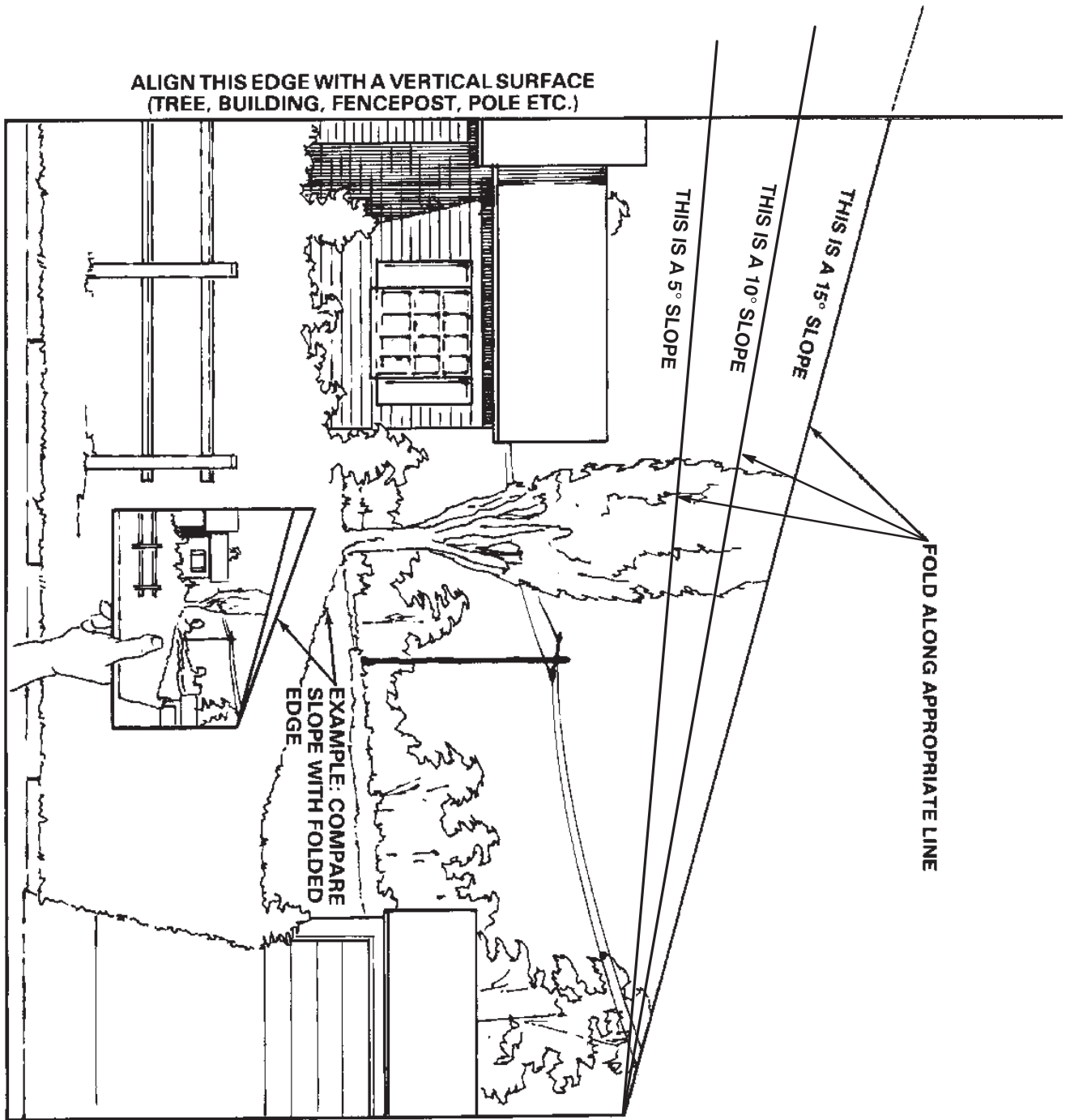



# Safety and Instruction Decals



Safety decals and instructions are easily visible to the operator and are located near any area of potential danger. Replace any decal that is damaged or lost.

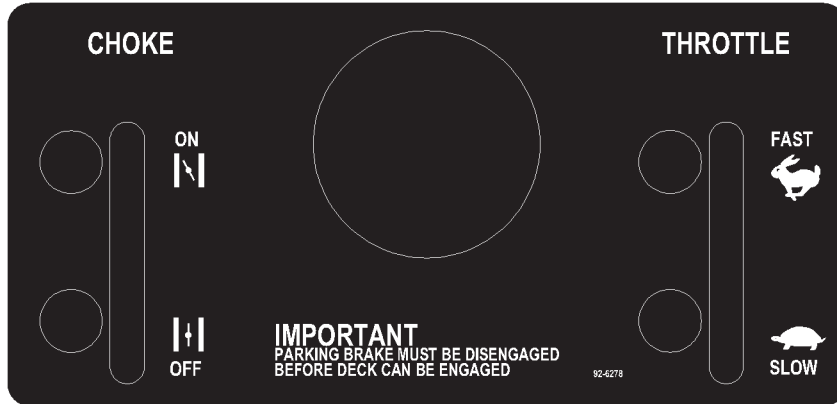

92-6278

## 120

### QUICK REFERENCE AID

CHECK/SERVICE

1. OIL LEVELS (ENGINE/TRANS)
2. AXLE OIL
3. TIRE PRESSURE
4. BELT TENSION (TRANS, PTO)
5. FUEL-GAS ONLY
6. BATTERY
7. GREASE, LUBE POINTS
8. ADJUST PARKING BRAKE
9. AIR CLEANER
10. ELECTRIC CLUTCH GAP .012-.018
11. DEBRIS UNDER HOOD & SEAT PLATE & ENGINE COOLING FINS

FLUID SPECIFICATION \* SEE OPERATOR'S MANUAL FOR INITIAL CHANGE

A. ENGINE OIL*	TYPE > 32	TYPE < 32	CAPACITY	CHANGE INTERVALS	FILTER PART NO.
	SAE 10W-30 OR 15W-40 SF OR SG	SAE 5W-20 OR 5W-30 SF OR SG	4 PT.	50 HRS.	FILTER 100 HRS KOHLER 12 050 D1
B. TRANS OIL	SAE 10W-30 SF-CC,CD	TYPE F OR FA TRANS FLUID	5 QT.	250 HRS.	FILTER 250 HRS 54-0110
C. FUEL	UNLEADED FUEL		5 GAL.		FILTER 400 HRS 38-8000
D. AXLE OIL	SAE E.R 90 WT.		44 OZ.	500 HRS	
E. AIR FILTER	ENGINE (FROM KOHLER)				47 083 03
	REMOTE				33-1300

92-6288

**POISON / DANGER -- CAUSES SEVERE BURNS**  
 Contains sulfuric acid. -Avoid contact with skin, eyes or clothing. -Antidote EXTERNAL-Flush with water. INTERNAL-Drink large quantities water or milk. Follow with milk of magnesia, beaten egg or veg oil. Call physician immediately. Eyes Flush with water for 15 minutes and get prompt medical attention. Batteries produce explosive gases. Keep sparks, flame, cigarettes away. Ventilate when charging or using in enclosed space. Always shield eyes when working near batteries.  
**KEEP OUT OF REACH OF CHILDREN**

26-7390



53-4430

**CAUTION**

CHECK PERFORMANCE OF ALL INTERLOCK SWITCHES DAILY. DO NOT DEFEAT INTERLOCK SYSTEM. IT IS FOR YOUR PROTECTION. READ AND UNDERSTAND OPERATORS MANUAL BEFORE OPERATING THIS MACHINE.

1. DISENGAGE IMPLEMENT BEFORE RAISING TO TRANSPORT POSITION.  
 2. DO NOT OPERATE IMPLEMENT IN TRANSPORT POSITION.  
 3. KEEP ALL SHIELDS IN PLACE.  
 4. BEFORE LEAVING OPERATOR'S POSITION;  
 A. DISENGAGE POWER TAKE-OFF.  
 B. SET PARKING BRAKE.  
 C. SHUT OFF ENGINE.  
 D. REMOVE IGNITION KEY.  
 5. WAIT FOR ALL MOVEMENT TO STOP BEFORE SERVICING.  
 6. STOP ENGINE BEFORE ADDING FUEL OR LIFTING HOOD.  
 7. KEEP PEOPLE AND PETS A SAFE DISTANCE AWAY FROM MACHINE.

TRACTION PEDAL INSTRUCTIONS

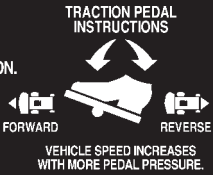

VEHICLE SPEED INCREASES WITH MORE PEDAL PRESSURE.

READ AND UNDERSTAND OPERATORS MANUAL BEFORE OPERATING THIS MACHINE. REPLACEMENT MANUAL AVAILABLE BY SENDING COMPLETE MODEL NUMBER TO: THE TORO CO., 8111 LYNDALE AVE. S., BLOOMINGTON, MN 55420-1196.

54-0880

**IMPLEMENT LIFT CONTROL**

↓ LOWER      RAISE ↑

54-0900



**WARNING**  
HOT SURFACES

54-0910

(P)  
PARKING BRAKE

ON

OFF

54-0920

**WARNING**

**SPRING LOADED MECHANISM**  
SEE OPERATOR'S MANUAL FOR DISASSEMBLY PROCEDURE. 55-4300

55-4300

**WARNING**

**THIS ARM CAN SPRING UPWARD!**  
SEE OPERATORS MANUAL FOR DISASSEMBLY PROCEDURE.

61-3610

**WARNING**



**HOT**

63-8440

1. Hot surface

**WARNING**







**WARNING**

77-3100

1. Spinning blades can cut off fingers.

PTO ENGAGEMENT      IGNITION

ENGAGED       OFF  RUN

DISENGAGED        START

92-6277

**CAUTION**

1 INCH (25mm)

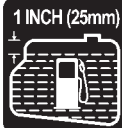

**STOP ENGINE BEFORE ADDING FUEL OR LIFTING HOOD. FILL FUEL TANK TO ONE INCH BELOW FILLER NECK. DO NOT OVERFILL.**

92-6291



**98-4387**

1. Warning—wear hearing protection.
-

# Gasoline and Oil

## Recommended Gasoline

Use **unleaded** Regular Gasoline suitable for automotive use (85 pump octane minimum). Leaded regular gasoline may be used if unleaded regular is not available.

**Important** Never use methanol, gasoline containing methanol, or gasohol containing more than 10% ethanol because the fuel system could be damaged. Do not mix oil with gasoline.



### Danger



In certain conditions, gasoline is extremely flammable and highly explosive. A fire or explosion from gasoline can burn you and others and can damage property.

- Fill the fuel tank outdoors, in an open area, when the engine is cold. Wipe up any gasoline that spills.
- Never fill the fuel tank inside an enclosed trailer.
- Do not fill the fuel tank completely full. Add gasoline to the fuel tank until the level is 1/4 to 1/2 in. (6 to 13 mm) below the bottom of the filler neck. This empty space in the tank allows gasoline to expand.
- Never smoke when handling gasoline, and stay away from an open flame or where gasoline fumes may be ignited by a spark.
- Store gasoline in an approved container and keep it out of the reach of children. Never buy more than a 30-day supply of gasoline.
- Always place gasoline containers on the ground away from your vehicle before filling.
- Do not fill gasoline containers inside a vehicle or on a truck or trailer bed because interior carpets or plastic truck bed liners may insulate the container and slow the loss of any static charge.
- When practical, remove gas-powered equipment from the truck or trailer and refuel the equipment with its wheels on the ground.
- If this is not possible, then refuel such equipment on a truck or trailer from a portable container, rather than from a gasoline dispenser nozzle.
- If a gasoline dispenser nozzle must be used, keep the nozzle in contact with the rim of the fuel tank or container opening at all times until fueling is complete.



### Warning



Gasoline is harmful or fatal if swallowed. Long-term exposure to vapors can cause serious injury and illness.

- Avoid prolonged breathing of vapors.
- Keep face away from nozzle and gas tank or conditioner opening.
- Keep gas away from eyes and skin.

## Using Stabilizer/Conditioner

Use a fuel stabilizer/conditioner in the machine to provide the following benefits:

- Keeps gasoline fresh during storage of 90 days or less. For longer storage it is recommended that the fuel tank be drained.
- Cleans the engine while it runs
- Eliminates gum-like varnish buildup in the fuel system, which causes hard starting

**Important** Do not use fuel additives containing methanol or ethanol.

Add the correct amount of gas stabilizer/conditioner to the gas.

**Note:** A fuel stabilizer/conditioner is most effective when mixed with fresh gasoline. To minimize the chance of varnish deposits in the fuel system, use fuel stabilizer at all times.

## Filling the Fuel Tank

1. Shut the engine off and set the parking brake.
2. Clean around each fuel tank cap and remove the cap. Add unleaded regular gasoline to both fuel tanks, until the level is 1/4 to 1/2 inch (6 mm to 13 mm) below the bottom of the filler neck. This space in the tank allows gasoline to expand. Do not fill the fuel tanks completely full.
3. Install fuel tank caps securely. Wipe up any gasoline that may have spilled.

## Checking the Engine Oil Level

Before you start the engine and use the machine, check the oil level in the engine crankcase; refer to Checking the Oil Level, page 21.

# Assembly

**Note:** Determine the left and right sides of the machine from the normal operating position.

## Loose Parts

**Note:** Use the chart below to verify that all parts have been shipped.

Description	Qty.	Use
Spacer	1	Installing the steering wheel
Steering wheel	1	
Roll pin, 1/4 x 2-1/2 in.(64 mm)	1	
Seat	1	Installing the seat
Bolt, 5/16-18 x 1 in. (25 mm)	4	
Lock nut, 5/16	4	
R-clamp	1	
Weight	2	Installing the rear weight
Bolt, 1/2 x 3-1/2 in. (89 mm)	4	
Washer, 1/2 in. (13 mm)	4	
Lock washer, 1/2 in. (13 mm)	4	
Nut, 1/2 in.	4	
Carriage bolt, 1/4-20 x 3/4 in. (19 mm)	2	Installing the battery cables
Wing nut, 1/4	2	
Parts catalog	1	
Operator's Manual	1	Read before operating the machine.
Registration card	1	Fill out and return to Toro.

## Installing the Seat

1. Position the seat assembly onto the seat plate, aligning the mounting holes (Fig. 1).
2. Slide the wire clamp over the seat switch wire (Fig. 1).
3. Using the left front hole, loosely secure the wire clamp and seat to the seat base with capscrews and locknuts (Fig. 1).
4. Mount the seat to the seat base with the 3 remaining bolts and locknuts.
5. Route the seat switch wire through the slot in the seat plate and plug the connector onto the seat switch (Fig. 1).
6. Tighten all locknuts and check the operation of the seat.
7. Make sure the wire harness is clear of the lift arm and all moving parts.

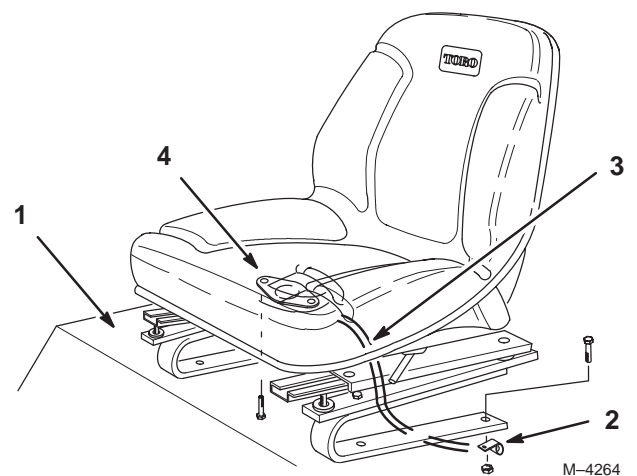
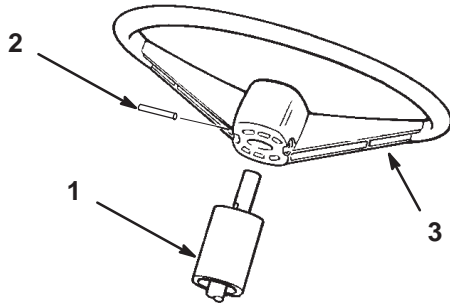

**Figure 1**

- |               |                          |
|---------------|--------------------------|
| 1. Seat plate | 3. Seat switch wire      |
| 2. R-clamp    | 4. Seat switch connector |

## Installing the Steering Wheel

1. Move the rear wheels so that they point straight ahead.
2. Slide the spacer and steering wheel onto the steering shaft, aligning the mounting holes. Check that the logo on the steering cap points forward.
3. Secure the steering wheel to the shaft with a roll pin (Fig. 2).



**Figure 2**

1. Spacer
2. Roll pin
3. Steering Wheel

M-4263

## Activating the Battery

Bulk electrolyte with 1.260 specific gravity must be purchased from a local battery supply outlet.



### Danger



Battery electrolyte contains sulfuric acid which is a deadly poison and causes severe burns.

- Do not drink electrolyte and avoid contact with skin, eyes or clothing. Wear safety glasses to shield your eyes and rubber gloves to protect your hands.
- Fill the battery where clean water is always available for flushing the skin.
- Follow all instructions and comply with all safety messages on the electrolyte container.

1. If the battery is already installed, remove it from the holder.
2. Remove the filler caps from the battery. Slowly pour electrolyte into each cell until the electrolyte level is up to the lower part of the tube (Fig. 3).

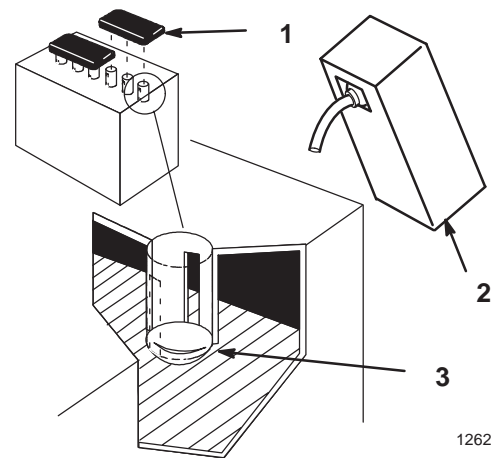
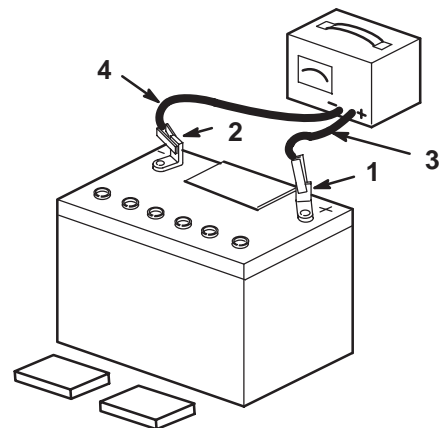

**Figure 3**

1. Filler caps
2. Electrolyte
3. Lower part of the tube

1262

3. Leave the covers off and connect a 3 to 4 amp battery charger to the battery posts (Fig. 4). Charge the battery at a rate of 4 amperes or less for 4 hours (12 volts).



**Figure 4**

1. Positive post
2. Negative post
3. Charger red (+) wire
4. Charger black (-) wire

1254



### Warning



Charging battery produces gasses that can explode and cause serious injury.

- Keep cigarettes, sparks and flames away from battery.
- Make sure the ignition switch is off.
- Ventilate when charging or using battery in an enclosed space.

4. When the battery is fully charged, disconnect the charger from the electrical outlet then from the negative and positive battery posts (Fig. 4).

- Slowly pour electrolyte into each cell until the level is up to the lower part of the tube (Fig. 3) and install the covers.
- Install the battery into the holder.

## Installing the Battery

**Important** Activate the battery with electrolyte and charge it before installing.

- Mount the battery on the battery support with the terminal posts toward the gas tank (Fig. 5).
- Secure the battery with the clamp, support rod, and wing nut (Fig. 5).

**Note:** Do not over tighten.

- Slide the red terminal boot onto the red battery cable (Fig. 5).
- Install the positive battery cable to positive (+) battery terminal and the negative battery cable to the negative (-) battery terminal and secure them with carriage bolts and locknuts (Fig. 5).

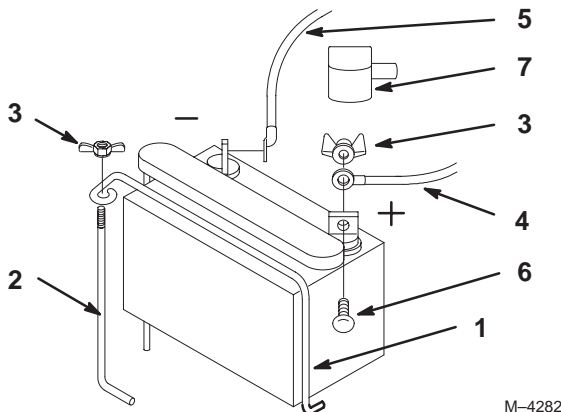

Figure 5

- |                           |                           |
|---------------------------|---------------------------|
| 1. Clamp                  | 5. Negative battery cable |
| 2. Support rod            | 6. Carriage Bolt          |
| 3. Wing nut               | 7. Terminal Boot          |
| 4. Positive battery cable |                           |

## Checking the Engine Oil

The engine is shipped with 4 pints of oil in the crankcase; however, the oil level must be checked before and after the engine is first started. Check the oil level; refer to Checking the Oil Level, page 21.

## Checking the Hydraulic System Fluid

The hydraulic system is shipped with approximately 5 quarts of 10W-30 engine oil; however, the oil level must be checked before the engine is first started. Check the oil level; refer to Checking the Hydraulic System Fluid, page 27.

## Operation

**Note:** Determine the left and right sides of the machine from the normal operating position.

## Think Safety First

Please carefully read all of the safety instructions and decals in the safety section. Knowing this information could help you, your family, pets, or bystanders avoid injury.

Become familiar with all of the controls before you start the engine and operate the machine.

The use of protective equipment for eyes, hearing, feet, and head is recommended.

! **Caution** !

**This machine produces sound levels in excess of 85dBA at the operator's ear and can cause hearing loss through extended periods of exposure.**

**Wear hearing protection when operating this machine.**

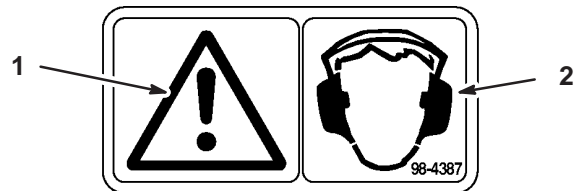

Figure 6

- Caution
- Wear hearing protection

## Starting and Stopping the Engine

### Starting

- Make sure that the spark plug wire(s) are installed on the spark plug(s).

2. Move the traction pedal to neutral, set the parking brake, and move the PTO switch to “OFF.”
3. Move the choke control to the “CHOKE” position before starting a cold engine.

**Note:** A warm or hot engine may not require any choking.

4. Rotate the ignition key to “START.” When the engine starts, release the key, gradually move the choke to run, and regulate the throttle to the desired speed.

**Important** To prevent overheating of the starter motor, do not engage the starter longer than 10 seconds. After 10 seconds of continuous cranking, wait 60 seconds before engaging the starter motor again.

## Stopping

1. Move the throttle lever to “SLOW” (Fig. 7).

**Note:** If the engine has been working hard or is hot, let it idle for a minute before turning the ignition key “OFF.” This helps cool the engine before it is stopped. In an emergency, the engine may be stopped by turning the ignition key to “OFF.”

2. Turn the ignition key to “OFF” (Fig. 7).
3. Set the parking brake.
4. Pull the wire off of the spark plug(s) to prevent the possibility of accidental starting before storing the machine.

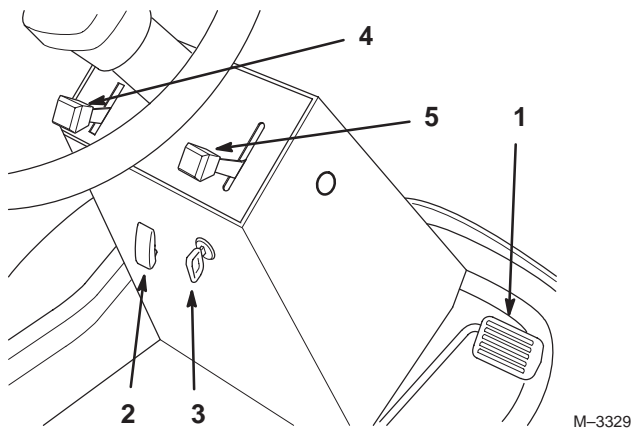

**Figure 7**

- |                    |             |
|--------------------|-------------|
| 1. Traction pedal  | 4. Choke    |
| 2. PTO switch      | 5. Throttle |
| 3. Ignition switch |             |

## Operating the Power Take Off (PTO)

The power take off (PTO) switch engages and disengages power to the electric clutch.

### Engaging the PTO

1. Release pressure on the traction pedal to stop movement. (Fig. 7).
2. Lift the cover and move the PTO switch to the “ON” position (Fig. 7).

### Disengaging the PTO

Closing the cover moves the PTO switch to the “OFF” position (Fig. 7).

## Driving Forward or Backward

The throttle control regulates the engine speed as measured in RPM (revolutions per minute). Move the throttle control to the “FAST” position for best performance.

### Forward

1. Place your foot on the traction pedal (Fig. 7).
2. Release the parking brake.
3. Slowly press on the upper pad of the traction pedal to move forward (Fig. 7).

### Backward

1. Place your foot on the traction pedal (Fig. 7).
2. Release the parking brake.
3. Slowly press on the lower pad of the traction pedal to move rearward (Fig. 7).

## Stopping the Machine

To stop the machine, release the pressure on the traction pedal, move the PTO switch to “OFF,” and turn the ignition key to “OFF” to stop the engine. Remove the key. Also set the parking brake if you leave the machine unattended; refer to Setting the Parking Brake, page 17.

**Caution**

**Children or bystanders may be injured if they move or attempt to operate the tractor while it is unattended.**

**Always remove the ignition and set the parking brake when leaving the machine unattended, even if just for a few minutes.**

## Parking Brake

Always set the parking brake when you stop the machine or leave it unattended.

### Setting the Parking Brake

1. Release pressure on the traction pedal to stop movement.
2. Lift the parking brake lever up to apply the parking brake (Fig. 8).

### Releasing the Parking Brake

Move the parking brake lever down to the released the parking brake (Fig. 8).

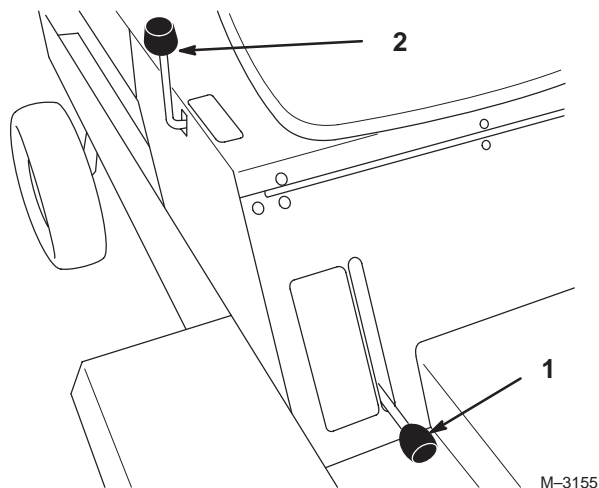

**Figure 8**

1. Parking brake                      2. Implement lift lever

## Implement Lift Lever

The implement lift lever (Fig. 8) is used to raise and lower various attachments.

## Raising Attachments

1. Remove pressure from traction pedal to stop the machine.
2. Pull implement lift lever (Fig. 8) rearward to raise attachment to the desired height.

## Lowering Attachments

1. Remove pressure from traction pedal to stop the machine.
2. Push implement lift lever (Fig. 8) forward to lower attachment.

**Note:** Hold lift lever in down position 1–2 seconds after attachment in down to extend lift cylinder allowing attachment to float with changes in ground contour.

## The Safety Interlock System

**Caution**

**If safety interlock switches are disconnected or damaged the machine could operate unexpectedly causing personal injury.**

- Do not tamper with the interlock switches.
- Check the operation of the interlock switches daily and replace any damaged switches before operating the machine.

### Understanding the Safety Interlock System

The safety interlock system is designed to prevent the engine from rotating or starting unless:

- The traction pedal is in neutral.
- The power take off (PTO) is disengaged.

The safety interlock system is designed to stop the engine if you rise from the seat when the PTO is engaged or the motion control is not in neutral.

### Testing the Safety Interlock System

Test the safety interlock system before you use the machine each time. If the safety system does not operate as described below, have an Authorized Service Dealer repair the safety system immediately.

1. Set the parking brake, move motion control to neutral, switch the power take off (PTO) “ON”. Now turn the key to “START”; the engine should not rotate.

2. Set the parking brake, turn the power take off (PTO) “OFF” and move the motion control (forward or reverse). Now turn the ignition key to “START”; the engine should not rotate.
3. Move the power take off (PTO) to disengaged, motion control to neutral, do not set parking brake. Now turn the key to “START”; the engine should not rotate.
4. Set the parking brake, move the power take off (PTO) to disengaged, motion control to neutral and start the engine. While the engine is running, engage the power take off (PTO) and rise slightly from the seat; the engine should stop.
5. Set the parking brake, move the power take off (PTO) to disengaged, motion control to neutral and start the engine. While the engine is running, slowly move the motion control (forward or reverse); the engine should stop.

**Important** The unit can be started when all controls are in a safe position, without the operator in the seat, for servicing.

## Positioning the Seat

The seat can move forward and backward. Position the seat where you have the best control of the machine and are most comfortable.

1. To adjust the seat move the lever on the left side of the seat rearward (Fig. 9).
2. Slide the seat to the desired position and release the lever to lock the seat into position.



M-4283

**Figure 9**

1. Seat adjustment lever

## Pushing or Towing the Machine

In an emergency, the traction unit can be pushed or towed for a very short distance. We do not recommend this as standard procedure.

**Important** Do not push or tow the traction unit faster than 2 to 3 MPH because the transmission may be damaged. If the traction unit must be moved a considerable distance, transport it on a truck or trailer.

1. To push or tow forward, the traction pedal must be fully depressed forward.
2. To push or tow in reverse, the traction pedal must be fully depressed in reverse.

# Maintenance



**Note:** Determine the left and right sides of the machine from the normal operating position.

## Recommended Maintenance Schedule

Maintenance Service Interval	Maintenance Procedure
After first 5 Hours	<ul style="list-style-type: none"> <li>• Oil—change</li> </ul>
Each Use	<ul style="list-style-type: none"> <li>• Oil—check level</li> <li>• Safety System—check</li> <li>• Brake—check</li> <li>• Engine—clean outside and cooling fins</li> </ul>
5 hours	<ul style="list-style-type: none"> <li>• Brake—check</li> </ul>
25 hours	<ul style="list-style-type: none"> <li>• Bearings and Bushings—grease<sup>1</sup></li> <li>• Foam Air Cleaner—clean<sup>1</sup></li> <li>• Paper Air Cleaner—clean<sup>1</sup></li> </ul>
50 hours	<ul style="list-style-type: none"> <li>• Oil—change<sup>1</sup></li> <li>• Belts—check for wear/cracks</li> <li>• Tires—check pressure</li> <li>• Battery—check electrolyte level</li> </ul>
100 hours	<ul style="list-style-type: none"> <li>• Oil Filter—change<sup>1</sup> (Every other oil change)</li> <li>• Engine—clean outside and cooling fins</li> <li>• Paper Air Cleaner—replace<sup>1</sup></li> <li>• Fuel Filter—replace</li> </ul>
200 hours	<ul style="list-style-type: none"> <li>• Spark Plug(s)—check</li> </ul>
250 hours	<ul style="list-style-type: none"> <li>• Hydraulic System—change oil</li> <li>• Hydraulic System—change filter</li> </ul>
500 hours	<ul style="list-style-type: none"> <li>• Front Axle—change oil</li> </ul>
At Storage	<ul style="list-style-type: none"> <li>• Chipped Surfaces—paint</li> <li>• Perform all maintenance procedures listed above before storage</li> </ul>

<sup>1</sup>More often in dusty, dirty conditions

**Important** Refer to your engine operator's manual for additional maintenance procedures.

Caution

**If you leave the key in the ignition switch, someone could accidentally start the engine and seriously injure you or other bystanders.**

**Remove the key from the ignition and disconnect the wire from the spark plug(s) before you do any maintenance. Set the wire aside so that it does not accidentally contact the spark plug.**

# Servicing the Air Cleaner

Foam Element: Clean and oil after every 25 operating hours.

Paper Element: Replace after every 100 operating hours.

**Note:** Service the air cleaner more frequently (every few hours) if operating conditions are extremely dusty or sandy.

## Removing the Foam and Paper Elements

1. Raise the seat
2. Disengage the power take off (PTO), set the parking brake, stop the engine, and remove the key.
3. Clean around the air cleaner to prevent dirt from getting into the engine and causing damage. Unscrew the knob and remove the air cleaner cover (Fig. 10).

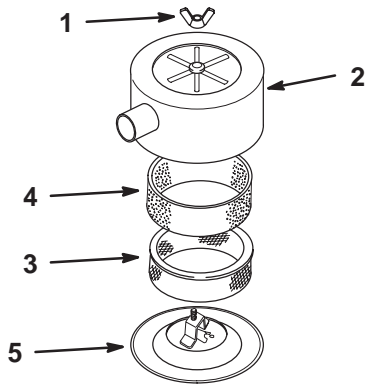

Figure 10

M-4284

- |             |                |
|-------------|----------------|
| 1. Wing nut | 4. Pre-filter  |
| 2. Cover    | 5. Filter Base |
| 3. Filter   |                |

4. Carefully slide the foam element off of the paper element (Fig. 10).
5. Unscrew the cover nut and remove the cover and paper element (Fig. 10).

## Cleaning the Foam Element

1. Wash the foam element in liquid soap and warm water. When the element is clean, rinse it thoroughly.
2. Dry the element by squeezing it in a clean cloth (do not wring).
3. Put one or two ounces of oil on the element (Fig. 11). Squeeze the element to distribute the oil.

**Important** Replace the foam element if it is torn or worn.

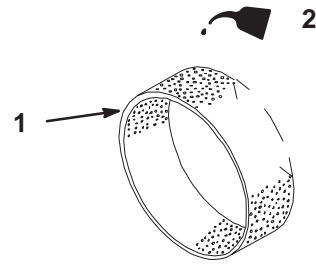

Figure 11

m-1213

- |                 |        |
|-----------------|--------|
| 1. Foam element | 2. Oil |
|-----------------|--------|

## Cleaning the Paper Element

1. Lightly tap the element on a flat surface to remove dust and dirt (Fig. 12).
2. Inspect the element for tears, an oily film, and damage to the rubber seal.

**Important** Never clean the paper element with pressurized air or liquids, such as solvent, gas, or kerosene. Replace the paper element if it is damaged, or cannot be cleaned thoroughly.

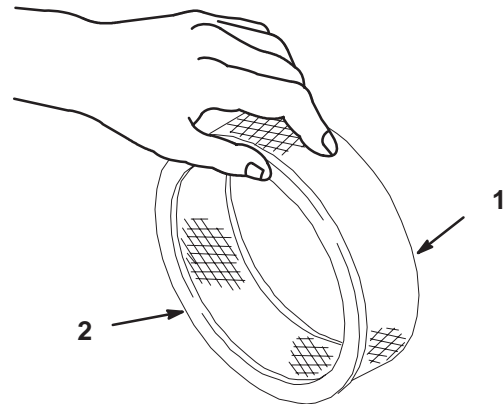

Figure 12

m-1213

- |                  |                |
|------------------|----------------|
| 1. Paper element | 2. Rubber seal |
|------------------|----------------|

## Installing the Foam and Paper Elements

1. Installing the Foam and Paper Elements

**Important** To prevent engine damage, always operate the engine with the complete foam and paper air cleaner assembly installed.

1. Carefully slide the foam element onto the paper air cleaner element (Fig. 10).
2. Place the air cleaner assembly onto the air cleaner base (Fig. 10).



## Changing the Oil Filter

Replace the oil filter every 100 hours or every other oil change.

**Note:** Change the oil filter more frequently when operating conditions are extremely dusty or sandy.

1. Drain the oil from the engine; refer to Changing and Draining the Oil, page 21.
2. Remove the old filter and wipe the filter adapter (Fig. 14 and 15) gasket surface.
3. Apply a thin coat of new oil to the rubber gasket on the replacement filter (Fig. 15).

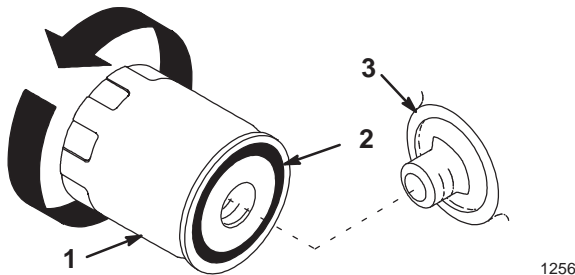

Figure 15

1. Oil filter
2. Gasket
3. Adapter

4. Install the replacement oil filter to the filter adapter. Turn the oil filter clockwise until the rubber gasket contacts the filter adapter, then tighten the filter an additional 1/2 turn (Fig. 15).
5. Fill the crankcase with the proper type of new oil; refer to Changing and Draining the Oil, page 21.

## Spark Plug Service

### Service Interval/Specification

Check the spark plug(s) after every 200 operating hours. Make sure that the air gap between the center and side electrodes is correct before installing the spark plug. Use a spark plug wrench for removing and installing the spark plug(s) and a gapping tool/feeler gauge to check and adjust the air gap. Install a new spark plug(s) if necessary.

Type: Champion RC 12YC (or equivalent)

Air Gap: 0.04 in. (1 mm)

### Removing the Spark Plug(s)

1. Disengage the power take off (PTO), set the parking brake, stop the engine, and remove the key.
2. To gain access to the rear spark plug, the gas tank must be removed (Fig. 16).



**Danger**



**In certain conditions, gasoline is extremely flammable and highly explosive. A fire or explosion from gasoline can burn you and others and can damage property.**

- **Drain gasoline from the fuel tank when the engine is cold. Do this outdoors in an open area. Wipe up any gasoline that spills.**
- **Never smoke when draining gasoline, and stay away from an open flame or where a spark may ignite the gasoline fumes.**

3. Rotate the tank and set it in the hood to prevent any fuel from spilling.
4. Push out the plastic cover from the access hole in the plate between the engine and gas tank.
5. Pull the wire(s) off of the spark plug(s). Now clean around the spark plug(s) to prevent dirt from falling into the engine and potentially causing damage.
6. Remove the spark plug(s) and metal washer.

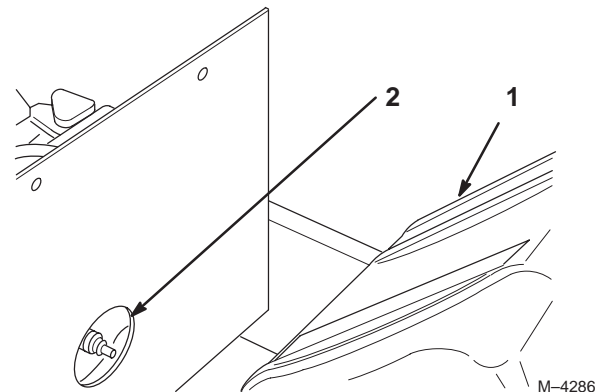

Figure 16

1. Fuel tank
2. Opening for access

### Checking the Spark Plug

1. Look at the center of the spark plug(s) (Fig. 17). If you see light brown or gray on the insulator, the engine is operating properly. A black coating on the insulator usually means the air cleaner is dirty.

**Important** Never clean the spark plug(s). Always replace the spark plug(s) when it has a black coating, worn electrodes, an oily film, or cracks.

2. Check the gap between the center and side electrodes (Fig. 17). Bend the side electrode (Fig. 17) if the gap is not correct.

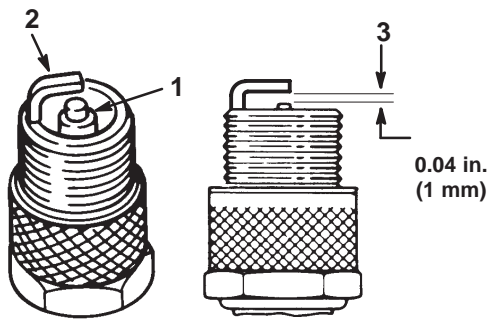

**Figure 17**

1. Center electrode insulator
2. Side electrode
3. Air gap (not to scale)

## Installing the Spark Plug(s)

1. Install the spark plug(s) and metal washer. Make sure that the air gap is set correctly.
2. Tighten the spark plug(s) to 12 ft.-lb. (17 N m).
3. Push the wire(s) onto the spark plug(s) (Fig. 16).
4. Push the plastic cover into the access hole in the plate between the engine and gas tank.
5. Lift the fuel tank and attach the fuel hose. Secure it with the hose clamp.
6. Rotate the fuel tank into position, hook the straps into the lower bracket, and secure it with capscrews and locknuts.

## Greasing and Lubrication

### Service Interval/Specification

Grease all bearings and bushings every 25 operating hours. Grease more frequently (daily) when operating conditions are extremely dusty or sandy.

Grease Type: General-purpose lithium base grease

### How to Grease

1. Disengage the power take off (PTO), set the parking brake, stop the engine, and remove the key.
2. Clean the grease fittings with a rag. Make sure to scrape any paint off of the front of the fitting(s).
3. Connect a grease gun to the fitting. Pump grease into the fittings until grease begins to ooze out of the bearings.
4. Wipe up any excess grease.

## Where to Add Grease

1. Lubricate the wheel bearings (Fig. 18).

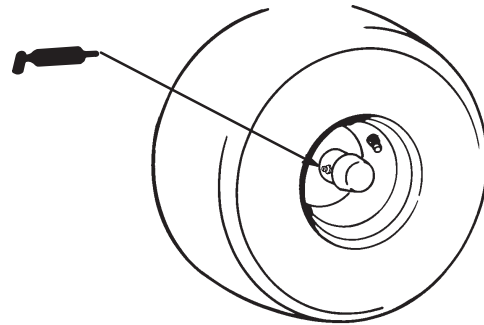

**Figure 18**

M-4287

2. Lubricate the spindles, steering shaft, and pivot (Fig. 19).

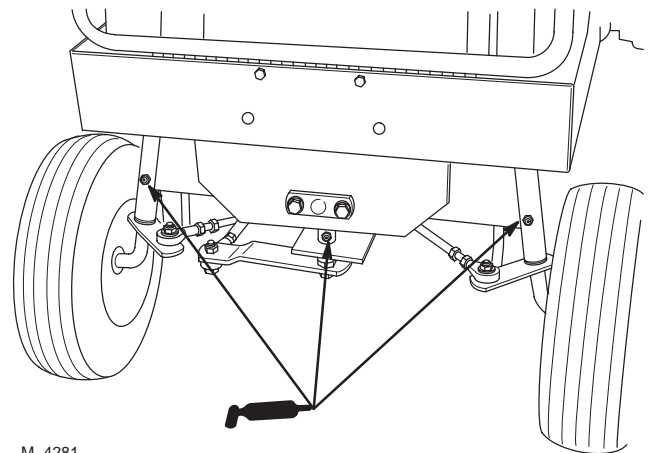

M-4281

**Figure 19**

3. Lubricate the axle bearings (Fig. 20).

Once a year, grease the front wheel hub to prevent the formation of rust and to simplify future wheel removal.

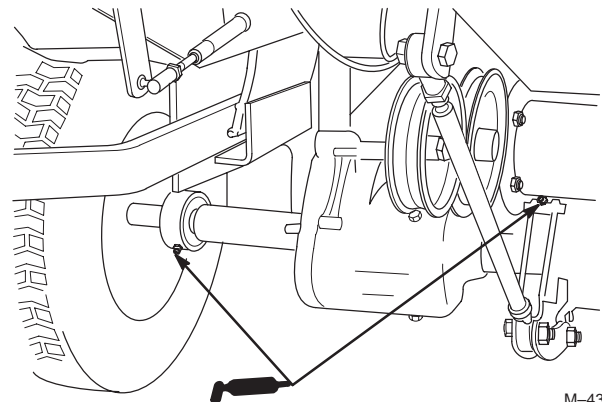

M-4371

**Figure 20**

- Lubricate the traction pedal bushings and steering shaft with a few drops of SAE 10W-30 oil or dry spray lube (Fig. 21).

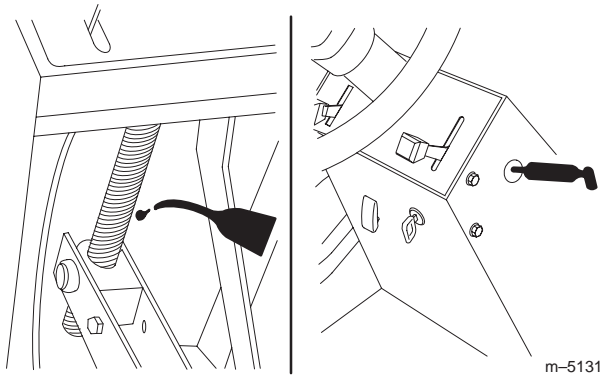

Figure 21

## Brake Service

Always set the parking brake when you stop the machine or leave it unattended. If the parking brake does not hold securely, an adjustment is required.

### Checking the Brake

- Park the machine on a level surface, disengage the power take off (PTO), set the parking brake, stop the engine, and remove the key.
- The drive wheels must lock when the brake is applied. An adjustment is required if the wheels turn and do not lock; refer to Adjusting the Brake, page 24.
- Release the brake. The wheels should rotate freely.
- If both conditions are met no adjustment is required.

**Important** With the parking brake released, the drive wheels must rotate freely. If brake action and free wheel rotation cannot be achieved, contact your service dealer immediately.

### Adjusting the Brake

If the drive wheels do not rotate freely when the brake lever is in the OFF position, or the brake does not hold when the lever is in the ON position, an adjustment is required.

- Move the brake lever to the ON position.
- Measure the distance between the disc brake actuating arm and stop pin on the axle bracket assembly (Fig. 22). The distance should be less than 1/4 in. (6 mm).

- If the distance is greater than 1/4 in. (6 mm), tighten the locknut to decrease the distance between the actuating arm and stop pin (Fig. 22).
- With the brake lever OFF, check the clearance between the brake pads and disc with a feeler gauge (Fig. 22). Proper clearance is approximately 0.01 in. (.25 mm).
- The actuating arm should be no more than 3/8 in. (10 mm) away from the stop with the brake lever in the ON position.
- Check the brake operation again; refer to Checking the Brake, page 24.
- Check the adjustment. The drive wheels should rotate freely when the brake lever is in the OFF position.

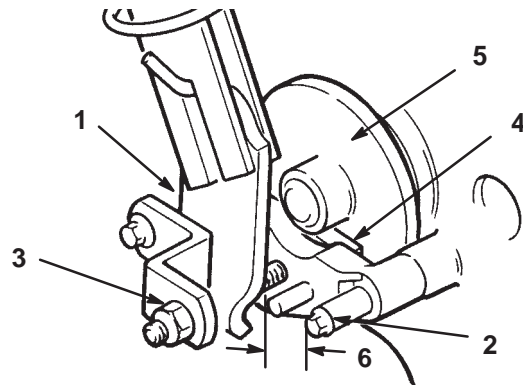

Figure 22

- |                        |                  |
|------------------------|------------------|
| 1. Brake actuating arm | 4. Brake pad (2) |
| 2. Stop pin            | 5. Disc          |
| 3. Locknut             | 6. 1/4 in. (6mm) |

2183

## Replacing the Fuel Filter

Replace the fuel filter after every 100 operating hours or yearly, whichever occurs first.

Never install a dirty filter if it is removed from the fuel line.

- Disengage the power take off (PTO), set the parking brake, stop the engine, and remove the key.
- Have a container ready to drain fuel from the tank. It is best to change the fuel filter when the fuel tank is almost empty.
- Loosen the hose clamps and slide them up the hose, away from the filter (Fig. 23).
- Remove the filter from the fuel lines (Fig. 23).
- Install a new filter. If the filter has an arrow, install it with the arrow pointing toward the carburetor.

6. Move the hose clamps close to the filter and tighten them.

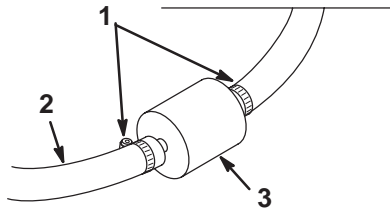

**Figure 23**

- |               |           |
|---------------|-----------|
| 1. Hose clamp | 3. Filter |
| 2. Fuel line  |           |

2261

## Tire Pressure Service

Maintain the air pressure in the front and rear tires as specified. Check the pressure at the valve stem after every 50 operating hours or monthly, whichever occurs first (Fig. 24). Check the tires when they are cold to get the most accurate pressure reading.

Pressure: 103 kPa (15 psi) front and rear

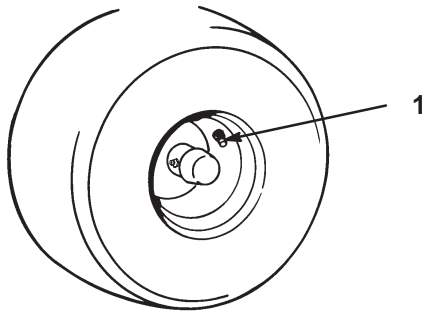

**Figure 24**

1. Valve stem

M-4287

## Cleaning the Cooling System

Before each use, remove grass clippings, dirt, and grime from the entire machine, muffler, and engine air intake screen. Every 100 operating hours clean dirt and chaff from the engine cylinder head fins and blower housing. This will help ensure adequate cooling and reduce the possibility of overheating and mechanical damage to the engine.

1. Open hood and pull the spark plug wire(s) off.
2. To avoid overheating and possible engine damage clean, grass, dust, dirt, and oil from the outside of the engine, air intake screen, and muffler.
3. To clean the cylinder head fins, remove the engine from the chassis and remove the cooling shrouds. Make sure that the cooling shrouds are installed before operating the engine.

## Adjusting the Belts

If belt slippage occurs, the idler pulleys must be adjusted to increase the belt tension.

1. Disengage the power take off (PTO), set the parking brake, stop the engine, and remove the key.
2. Raise the seat.
3. Measure the distance from the bottom of the spacer on the pulley mounting screw to the bottom of the slot in the idler adjustment link. The distance should be 1/4 in. (6 mm) or less (Fig. 25).
4. To adjust, remove the hairpin cotter and washer securing the tension bracket to the mounting pin (Fig. 25).
5. Slide the tension bracket off of the mounting pin. Adjust and select a new hole until the bottom of the spacer is within 1/4 in. (6 mm) from the bottom of the slot (Fig. 25).
6. Secure the tension bracket with the washer and hairpin cotter (Fig. 25).

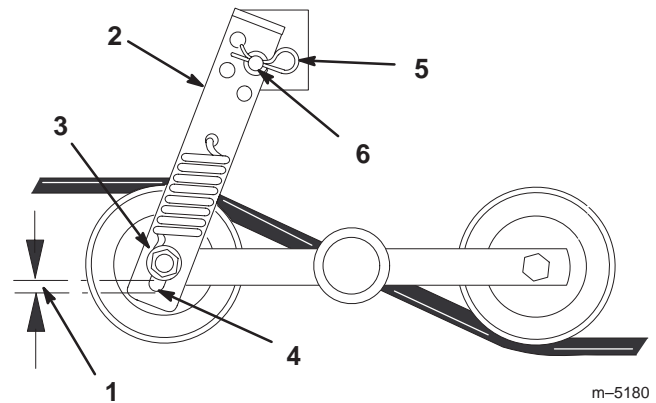

**Figure 25**

- |                          |                   |
|--------------------------|-------------------|
| 1. 1/4 in. (6 mm) space  | 4. Bottom of slot |
| 2. Tension bracket       | 5. Hairpin cotter |
| 3. Pulley mounting screw | 6. Mounting pin   |

m-5180

## Replacing the Belts

To replace the traction or jackshaft belt, use the following procedures and belt routing diagram (Fig. 26).

1. Disengage the power take off (PTO), set the parking brake, stop the engine, and remove the key.
2. Raise the seat.
3. Remove the clutch anchor bolt and unplug the clutch from the wire harness.
4. Release the tension in the idler pulleys before removing or installing the belts (Fig. 25).

5. Install the belts. Route the traction belt over the transmission as shown (Fig. 26).
6. Install the clutch anchor bolt and plug in the connector.

**Important** To avoid damage, install the clutch anchor bolt before connecting the wire.

7. Adjust the belt tension; refer to Adjusting the Belts, page 25.

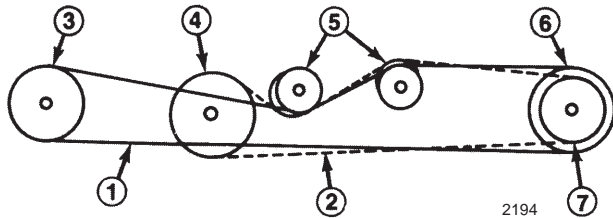

Figure 26

- |                        |                  |
|------------------------|------------------|
| 1. Jackshaft belt      | 5. Idler pulley  |
| 2. Traction belt       | 6. Clutch pulley |
| 3. Jackshaft pulley    | 7. Engine pulley |
| 4. Transmission pulley |                  |

## Adjusting the Lift Cylinder and Counterbalance Springs

1. Raise the seat.
2. Start the engine and lower the cutting unit lift arms until the lift cylinder is fully extended and lift (cutting unit) is fully lowered.
3. Measure the distance between the cylinder jam nuts and cylinder pivot pin (Fig. 27). The distance should be approximately 2-1/4 in. (57 mm).

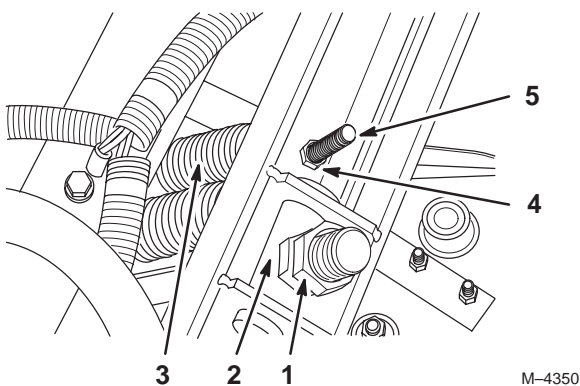

Figure 27

- |                          |                      |
|--------------------------|----------------------|
| 1. Jam nut               | 4. Adjustment nut    |
| 2. Cylinder pivot pin    | 5. Lift arm "T" hook |
| 3. Counterbalance spring |                      |

4. Loosen the jam nuts and adjust them, if necessary, to attain the needed clearance.

5. Start the engine and raise the lift arms until the lift cylinder is fully retracted and lift (cutting unit) is fully raised.
6. Check the distance between the clevis pin and bottom hooks of the springs (Fig. 25). The distance should be 1/4 in. (6 mm) or less.
7. Adjust the nut on the lift arm "T" hook to obtain the required distance.

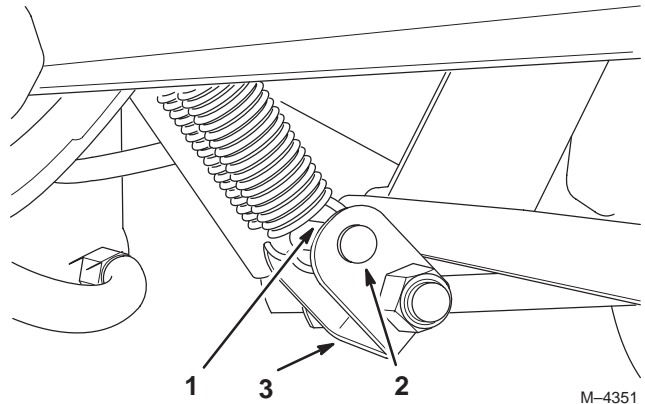

Figure 28

- |                              |                 |
|------------------------------|-----------------|
| 1. 1/4 in. (6 mm) clearance  | 3. Lift bracket |
| 2. Clevis pin and cotter pin |                 |

## Adjusting the Transmission Neutral

The machine must not creep when the traction pedal is released. If it does creep, an adjustment is required.

1. Park machine on a level surface, lower the cutting unit, and stop the engine. Disengage the PTO and engage the parking brake.
2. Raise the seat.
3. Jack up the front of the machine until the tires are off of the shop floor. Support the machine with jack stands to prevent it from falling accidentally.

⚠
Danger
⚠

**Mechanical or hydraulic jacks may fail to support machine and cause a serious injury.**

- Use jack stand when supporting machine.
- Do not use hydraulic jacks.

4. Loosen the locknut on the adjustment cam (Fig. 29).
5. Start the engine and rotate the adjusting cam in either direction until the wheels stop rotating (Fig. 29).



## Warning



Engine must be running so transmission neutral adjustment can be performed. Contact with moving parts or hot surfaces may cause personal injury.

Keep hands, feet, face, clothing and other body parts away from rotating parts, muffler and other hot surfaces.

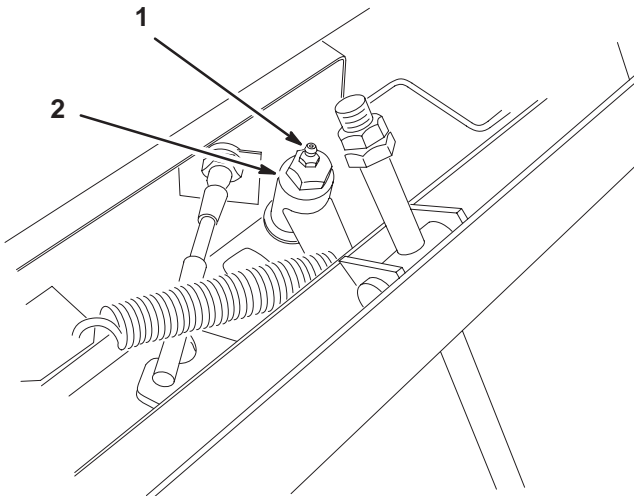

m-5179

Figure 29

1. Adjustment cam
2. Lock nut

6. Stop the engine and tighten the locknut to secure the adjustment (Fig. 29).
7. Start the engine and check the adjustment. Repeat the adjustment, if necessary.
8. Stop the engine. Remove the jack stands and lower the machine to the shop floor. Test drive the machine to be sure it does not creep.

## Adjusting the Electric Clutch

The clutch is adjusted to ensure proper engagement and braking action.

1. Disengage the power take off (PTO), set the parking brake, stop the engine, and remove the key.
2. To adjust the clutch, tighten or loosen the locknuts on the flange studs (Fig. 30).
3. Check the adjustment by inserting a feeler gauge through the slots next to the studs.

4. The proper disengaged clearance between the clutch plates is 0.012–0.018 in. (0.30–0.45 mm). It will be necessary to check this clearance at each of the three slots to ensure that the plates are parallel to each other.

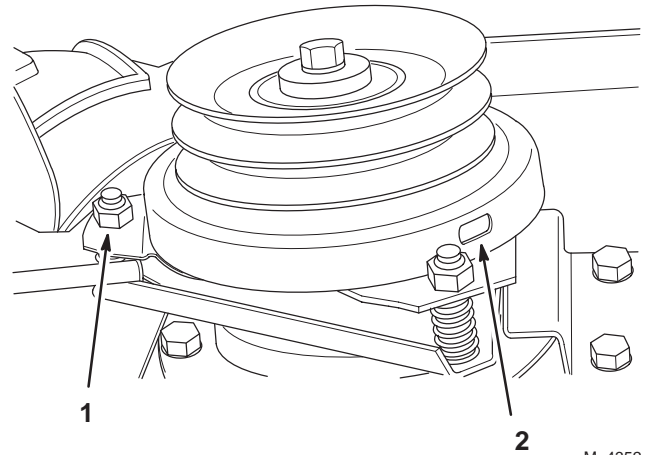

M-4352

Figure 30

1. Locknut
2. Adjustment slot

## Checking the Hydraulic System Fluid



## Warning



Hydraulic fluid escaping under pressure can penetrate skin and cause injury.

- If hydraulic fluid is injected into the skin it must be surgically removed within a few hours by a doctor familiar with this type of injury. Gangrene may result if this is not done.
- Keep body and hands away from pin hole leaks or nozzles that eject high pressure hydraulic fluid.
- Use cardboard or paper to find hydraulic leaks.
- Safely relieve all pressure in the hydraulic system before performing any work on the hydraulic system.
- Make sure all hydraulic fluid hoses and lines are in good condition and all hydraulic connections and fittings are tight before applying pressure to hydraulic system.

The hydraulic system is designed to operate on SAE 10W-30 engine oil or, as a substitute, SAE 10W-40 engine oil. The reservoir is filled at the factory with approximately 4.731 (5 U.S. quarts) of 10W-30 engine oil. Check the reservoir oil level before the engine is first started and daily thereafter.

1. Position the machine on a level surface and stop the engine.

2. Raise the seat.
3. Remove the dipstick cap from the filler neck (Fig. 31) and wipe it with a clean rag. Insert the dipstick cap onto the filler neck; then remove it and check the oil level.
4. If the level is not within 1/2 in. (13 mm) from the full mark on the dipstick, add SAE 10W-30 engine oil to raise the level to the FULL mark. Do not overfill.
5. Install the dipstick filler cap onto the filler neck (Fig. 31).
6. Run the engine for approximately 1 minute. Check the reservoir oil level and add oil as required.



**Figure 31**

1. Dipstick cap

## Changing the Hydraulic System Oil

The hydraulic system oil must be changed after every 250 hours of operation or yearly, whichever comes first. The reservoir has a capacity of approximately 4.731 (5 U.S. quarts).

1. Park the machine on a level surface, lower the cutting unit, engage the parking brake, and stop the engine.
2. Clean the area around the hydraulic oil filter and remove the filter from the bottom of the filter housing. Use a bottom type filter wrench (Fig. 32).
3. Disconnect the tube assembly and hose assembly from the reservoir and allow the oil to flow into a drain pan (Fig. 32).

**Note:** To drain remaining oil in the system, disconnect the spark plug wires and crank the engine for 15 seconds. This will pump the remaining oil out of the system through the tube assembly. Do not crank the engine for more than 15 seconds.

4. Install the new hydraulic filter onto the bottom of the filter housing (Fig. 32).

5. Install the tube assembly and hose assembly to the reservoir (Fig. 32).

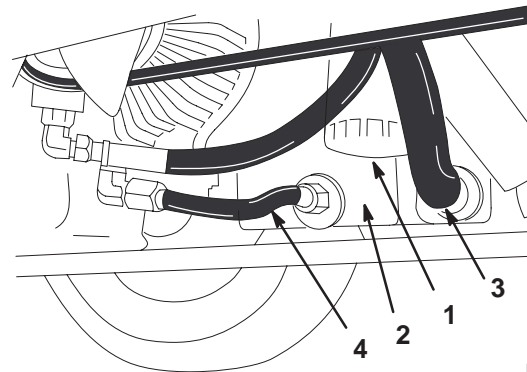

m-5156

**Figure 32**

1. Filter
2. Reservoir
3. Hose assembly
4. Tube assembly

6. Fill the reservoir to the proper level; refer to Checking the Hydraulic System Fluid, page 27.
7. Place all controls in the neutral or disengaged position and start the engine. Run the engine at the lowest possible RPM to purge the system of air.
8. Run the engine until the lift cylinder extends and retracts and forward and reverse wheel motion is achieved.
9. Stop the engine and check the oil level in reservoir. Add oil if necessary.
10. Check all connections for leaks.

## Changing the Hydraulic Oil Filter

The hydraulic oil filter keeps the hydraulic system relatively free of contaminants. However, the hydraulic oil filter must be serviced at regular intervals. The intervals are: initially, after the first 5 hours of operation, and thereafter every 250 hours of operation or yearly, whichever comes first. Use a genuine Toro oil filter for replacement.

1. Remove the hydraulic oil filter from the mounting head. Use a bottom type filter wrench (Fig. 32). Dispose of the filter properly.
2. Apply a film of oil on the gasket. Install the filter by hand until the gasket contacts the mounting head; then tighten the filter an additional 3/4 turn.
3. Start the engine and check for oil leaks. Allow the engine to run for about 2 minutes so that any air in the system is purged. Then shut the engine off.
4. Check the oil level in the reservoir; refer to Checking the Hydraulic System Fluid, page 27.

## Adjusting the Steering

1. Measure the toe-in distance (at axle height) at the front and rear of the steering tires. The front measurement must be 0–1/4 in. (6 mm) less than the rear measurement.
2. Loosen the jam nuts and rotate the tie rod to adjust the clearance (Fig. 33).
3. Turn the steering wheel full left to achieve a full left turn (Fig. 33).
4. Check the clearance between the left tire and tie rod. There should be 1 in. (25 mm) ± 1/4 inch (6 mm) clearance at this position.
5. Loosen the jam nuts and rotate the steering rod to adjust the clearance (Fig. 33).
6. Rotate the tie rod to move the front of the tire in or out.
7. Tighten the jam nuts when the adjustment is correct.

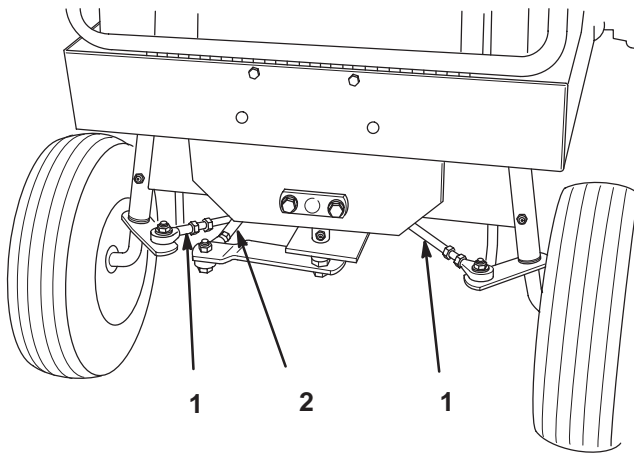

M-4281

**Figure 33**

1. Tie rod
2. Steering rod

## Changing the Front Axle Oil

After every 500 hours of operation, change oil in the front axle.

1. Run the machine before changing the oil to warm the oil. Warm oil flows more freely and carries more contaminants than cold oil.
2. Clean the area around the drain plug and place a drain pan below the drain plug on the axle (Fig. 34).
3. Remove the drain plug and allow the oil to flow into the drain pan (Fig. 34). After the oil is drained, install the drain plug.

4. Remove the fill plug and fill to the plug level with SAE EP-90 wt. oil (approximately 14.9cl [44 oz.]) (Fig. 34).

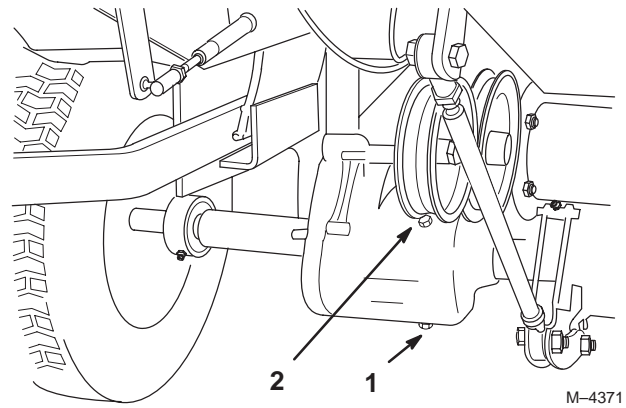

M-4371

**Figure 34**

1. Drain plug
2. Fill plug

## Servicing the Battery



### Warning



**Battery posts, terminals, and related accessories contain lead and lead compounds, chemicals known to the State of California to cause cancer and reproductive harm. Wash hands after handling.**

### Service Interval/Specification

Check the electrolyte level in the battery every 50 hours. Always keep the battery clean and fully charged. Use a paper towel to clean the battery case. If the battery terminals are corroded, clean them with a solution of four parts water and one part baking soda. Apply a light coating of grease to the battery terminals to prevent corrosion.

Voltage: 12 v, 280 Cold Cranking Amps

### Checking the Electrolyte Level

1. Raise the seat.
2. With the engine off, open the covers to see into the cells. The electrolyte must be up to the lower part of the tube (Fig. 35). Do not allow the electrolyte to get below the plates. (Fig. 35).
3. If the electrolyte is low, add the required amount of distilled water; refer to Adding Water to the Battery, page 30.

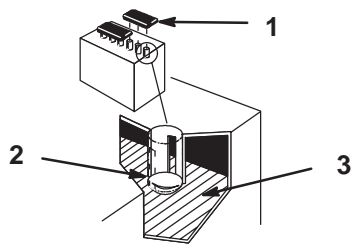

Figure 35

1262

1. Filler caps
2. Lower part of tube
3. Plates

## Adding Water to the Battery

The best time to add distilled water to the battery is just before you operate the machine. This lets the water mix thoroughly with the electrolyte solution.

1. Clean the top of the battery with a paper towel.
2. Lift off the filler caps (Fig. 35).
3. Slowly pour distilled water into each battery cell until the level is up to the lower part of the tube (Fig. 35).

**Important** Do not overfill the battery because electrolyte (sulfuric acid) can cause severe corrosion and damage to the chassis.

4. Press the filler caps onto the battery.

## Charging the Battery

**Important** Always keep the battery fully charged (1.260 specific gravity). This is especially important to prevent battery damage when the temperature is below 0°C (32°F).

1. Raise the seat.
2. Remove the battery from the holder.
3. Check the electrolyte level; refer to Checking the Electrolyte Level.
4. Remove the filler caps from the battery and connect a 3 to 4 amp battery charger to the battery posts. Charge the battery at a rate of 4 amperes or less for 4 hours (12 volts). Do not overcharge the battery. Install the filler caps after the battery is fully charged.



## Warning



Charging battery produces gasses that can explode and cause serious injury.

- Keep cigarettes, sparks and flames away from battery.
- Make sure the ignition switch is off.
- Ventilate when charging or using battery in an enclosed space.

5. Install the battery into the holder.

## Servicing the Wire Harness

To prevent corrosion of the wiring terminals, apply Grafo 112X (Skin-over) grease to the inside of all harness connectors whenever the harness is replaced.

Whenever working with the electrical system, always disconnect the battery cables, negative (-) cable first, to prevent possible wiring damage from short-outs.

**Important** Before welding on the machine, disconnect the ground cable from the battery to prevent damage to the electrical system.

## Waste Disposal

Engine oil, hydraulic oil, and engine coolant are pollutants to the environment. Dispose of these according to your state and local regulations.

## Transporting Machines

Use a heavy-duty trailer or truck to transport the machine. Ensure that the trailer or truck has all necessary lighting and marking as required by law. Please carefully read all of the safety instructions and decals in the safety section. Knowing this information could help you, your family, pets, or bystanders avoid injury.

To transport the machine:

1. Lock the brake and block the wheels.
2. Securely fasten the machine to the trailer or truck with straps, chains, cable, or ropes.
3. Secure a trailer to towing vehicle with safety chains.

# Hydraulic Schematic

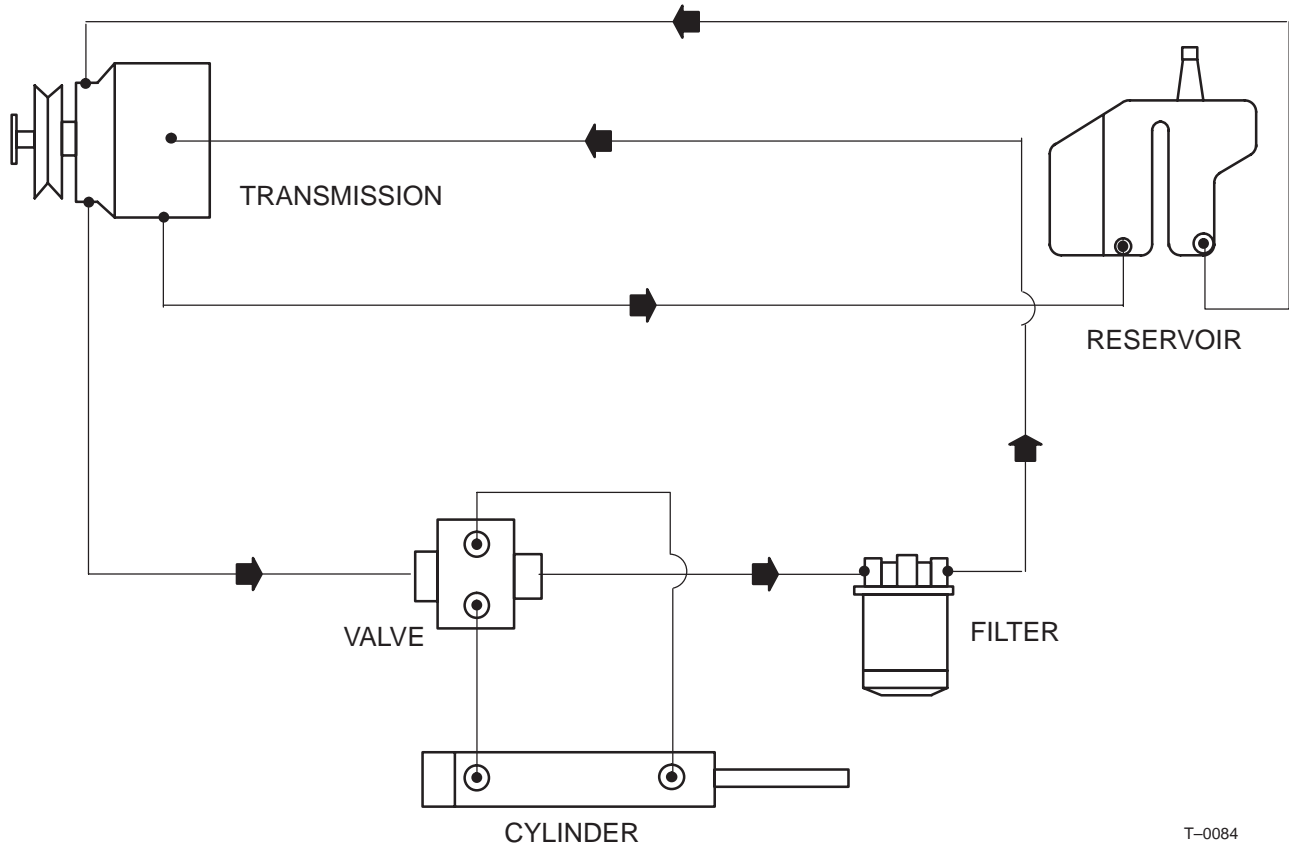

T-0084

## GM 120 QUICK REFERENCE AID



### CHECK/SERVICE

1. OIL LEVELS (ENGINE/TRANS)
2. AXLE OIL
3. TIRE PRESSURE
4. BELT TENSION (TRANS, PTO)
5. FUEL-GAS ONLY
6. BATTERY
7. GREASE, LUBE POINTS
8. ADJUST PARKING BRAKE
9. AIR CLEANER
10. ELECTRIC CLUTCH GAP .012-.018
11. DEBRIS UNDER HOOD & SEAT PLATE & ENGINE COOLING FINS

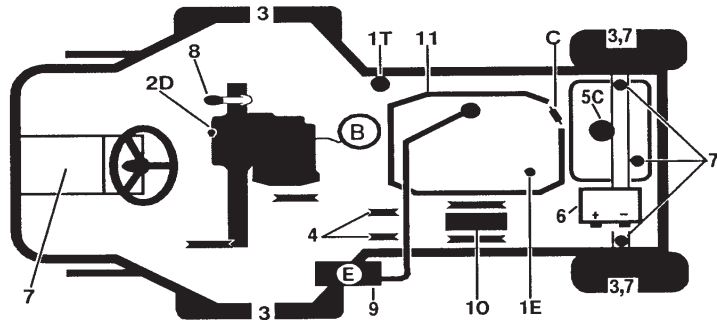

92-5288

### FLUID SPECIFICATION \* SEE OPERATOR'S MANUAL FOR INITIAL CHANGE

A. ENGINE OIL*	TYPE >	TYPE <	CAPACITY	CHANGE INTERVALS	FILTER	FILTER PART NO.
	SAE 10W-30 OR 10W-40 SF OR SG	SAE 5W-20 OR 5W-30 SF OR SG	1.9L (4PT.)	50 HRS.	FILTER 100 HRS	KOHLER 12 050 01
B. TRANS OIL	SAE 10W-30 SF-CC,CD	TYPE F OR FA TRANS FLUID	4.73L (5QT.)	250 HRS.	FILTER 250 HRS	54-0110
C. FUEL	UNLEADED FUEL		18.93L (5GAL.)	---	FILTER 400 HRS	38-8000
D. AXLE OIL	SAE E.R 90 WT.		14.9cl (44oz.)	500 HRS		
E. AIR FILTER	STANDARD					33-1300

# Wiring Diagram

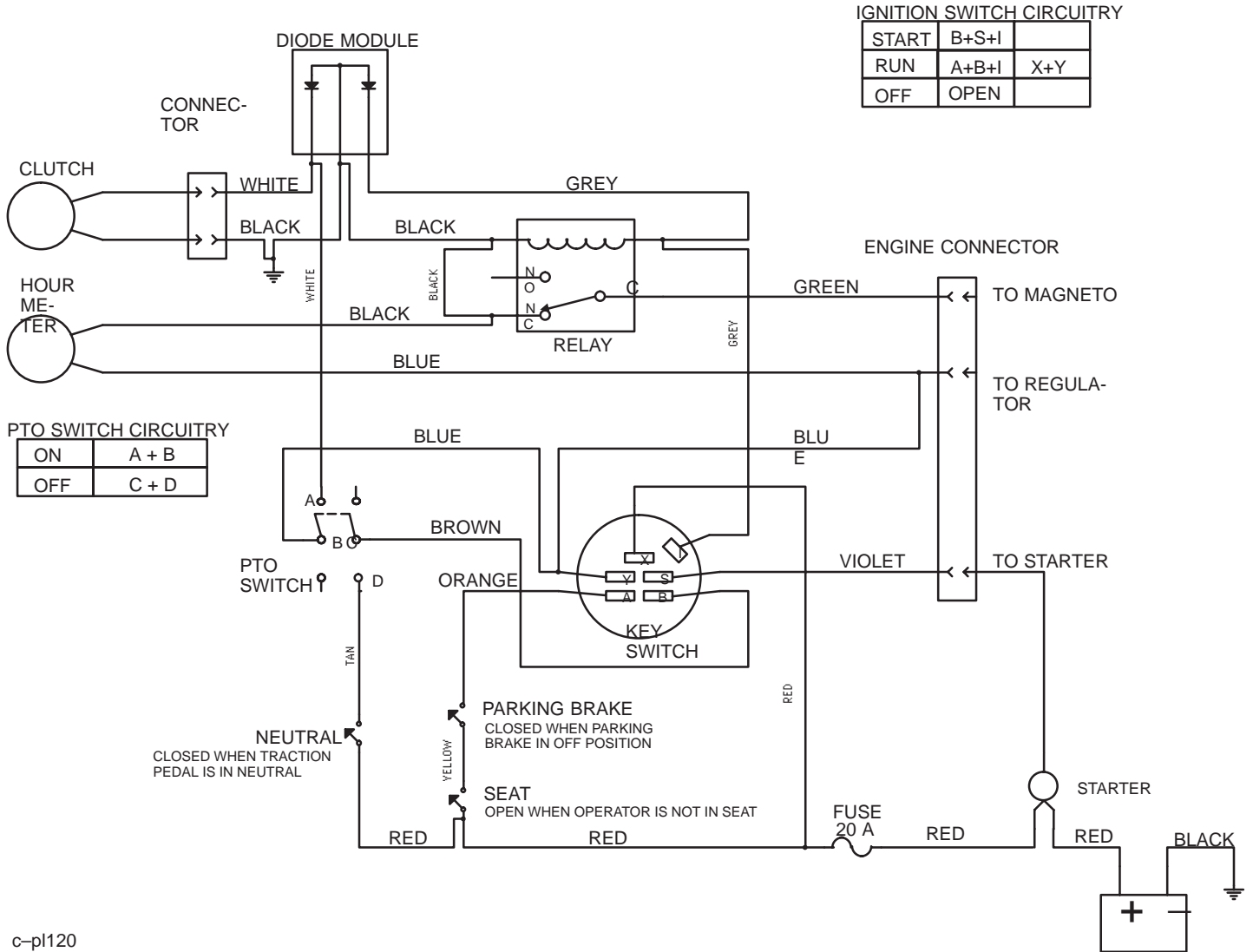

c-p1120

## Cleaning and Storage

1. Disengage the power take off (PTO), set the parking brake, and turn the ignition key to "OFF" to stop the engine. Remove the key.
  2. Remove grass clippings, dirt, and grime from the external parts of the entire machine, especially the engine. Clean dirt and chaff from the outside of the engine cylinder head fins and blower housing.
- Important** You can wash the machine with mild detergent and water. Do not pressure wash the machine. Avoid excessive use of water, especially near the control panel, and engine.
3. Check the brake; refer to Brake Service, page 24.
  4. Service the air cleaner; refer to Servicing the Air Cleaner, page 20.
  5. Grease the machine; refer to Greasing and Lubrication, page 23.
  6. Change the crankcase oil and filter; refer to the Engine Oil Service, page 21.
  7. Change the hydraulic system oil and filter; refer to Changing the Hydraulic Oil and Filter, page 28.
  8. Remove the battery from the chassis, check the electrolyte level, and charge fully; refer to Servicing the Battery, page 29. Do not connect the battery cables to the battery posts during storage.

**Important** The battery must be fully charged to prevent it from freezing and being damaged at temperatures below 0° C (32° F). A fully charged battery maintains its charge for about 50 days at temperatures lower than 4° C (40° F). If temperatures will be above 4° C (40° F), check the electrolyte level in the battery and charge every 30 days.

9. Check the tire pressure; refer to Tire Pressure Service, page 25.
10. During long-term storage, either drain gasoline from the fuel tank (step 11) or add a fuel stabilizer/conditioner additive to a full tank of gasoline (step A).
11. Drain gasoline from the fuel tank. After fuel is drained, start the engine and let it idle until all gasoline is consumed and the engine stops. This eliminates gum-like buildup in the fuel system, which causes hard starting. Try to start the engine two more times to assure that no gasoline is in the fuel system.
  - A. Add the correct amount of a fuel stabilizer/conditioner to a full tank of gasoline.

**Note:** Stabilizer/conditioners normally preserve gasoline for six to eight months.

12. Remove the spark plug(s) and check its condition; refer to Spark Plug, page 22. With the spark plug(s) removed from the engine, pour two tablespoons of engine oil into the spark plug hole. Now use the starter to crank the engine and distribute the oil inside the cylinder. Install the spark plug(s). Do not install the wire on the spark plug(s).
13. Check and tighten all bolts, nuts, and screws. Repair or replace any part that is worn or damaged.
14. Paint all scratched or bare metal surfaces. Paint is available from your Authorized Service Dealer.
15. Store the machine in a clean, dry garage or storage area. Remove the key from the ignition switch and keep it in a memorable place. Cover the machine to protect it and keep it clean.

## Troubleshooting

Problem	Possible Causes	Corrective Action
The starter does not rotate.	<ol style="list-style-type: none"> <li>1. The power take off (PTO) switch is engaged.</li> <li>2. The traction control pedal is not in neutral.</li> <li>3. The electrical connections are corroded or loose.</li> <li>4. A fuse is blown.</li> <li>5. The battery is dead.</li> <li>6. A solenoid or switch is malfunctioning.</li> </ol>	<ol style="list-style-type: none"> <li>1. Move the PTO switch to DISENGAGED.</li> <li>2. Move the traction control pedal to the neutral position</li> <li>3. Check the electrical connections for good contact.</li> <li>4. Replace the fuse.</li> <li>5. Charge the battery.</li> <li>6. Contact an Authorized Service Dealer.</li> </ol>

<b>Problem</b>	<b>Possible Causes</b>	<b>Corrective Action</b>
The engine will not start, starts hard, or fails to keep running.	<ol style="list-style-type: none"> <li>1. The operator is not seated.</li> <li>2. The parking brake is off.</li> <li>3. The fuel tank is empty.</li> <li>4. The choke is not on.</li> <li>5. The air cleaner is dirty.</li> <li>6. The spark plug wire(s) is loose or disconnected.</li> <li>7. The spark plug(s) is pitted, fouled, or the gap is incorrect.</li> <li>8. There is dirt in the fuel filter.</li> <li>9. Dirt, water, or stale fuel is in the fuel system.</li> </ol>	<ol style="list-style-type: none"> <li>1. Sit on the seat.</li> <li>2. Move the parking brake to ON.</li> <li>3. Fill the fuel tank with gasoline.</li> <li>4. Move the choke lever to ON.</li> <li>5. Clean or replace the air cleaner element.</li> <li>6. Install the wire(s) on the spark plug(s).</li> <li>7. Install a new, correctly-gapped spark plug(s).</li> <li>8. Replace the fuel filter.</li> <li>9. Contact an Authorized Service Dealer.</li> </ol>
The engine loses power.	<ol style="list-style-type: none"> <li>1. The engine load is excessive.</li> <li>2. The air cleaner is dirty.</li> <li>3. The oil level in the crankcase is low.</li> <li>4. The cooling fins and air passages under the engine blower housing are plugged.</li> <li>5. A spark plug(s) is pitted, fouled, or the gap is incorrect.</li> <li>6. The vent hole in the fuel cap is plugged.</li> <li>7. There is dirt in the fuel filter.</li> <li>8. Dirt, water, or stale fuel is in the fuel system.</li> </ol>	<ol style="list-style-type: none"> <li>1. Reduce your ground speed.</li> <li>2. Clean the air cleaner element.</li> <li>3. Add oil to the crankcase.</li> <li>4. Remove the obstruction from the cooling fins and air passages.</li> <li>5. Install a new, correctly-gapped spark plug(s).</li> <li>6. Clean or replace the fuel cap.</li> <li>7. Replace the fuel filter.</li> <li>8. Contact an Authorized Service Dealer.</li> </ol>
The engine overheats.	<ol style="list-style-type: none"> <li>1. The engine load is excessive.</li> <li>2. The oil level in the crankcase is low.</li> <li>3. The cooling fins and air passages under the engine blower housing are plugged.</li> </ol>	<ol style="list-style-type: none"> <li>1. Reduce your ground speed.</li> <li>2. Add oil to the crankcase.</li> <li>3. Remove the obstruction from the cooling fins and air passages.</li> </ol>
There is abnormal vibration.	<ol style="list-style-type: none"> <li>1. The engine mounting bolts are loose.</li> <li>2. There is a loose engine pulley, idler pulley, or blade pulley.</li> <li>3. The engine pulley is damaged.</li> </ol>	<ol style="list-style-type: none"> <li>1. Tighten the engine mounting bolts.</li> <li>2. Tighten the appropriate pulley.</li> <li>3. Contact an Authorized Service Dealer.</li> </ol>
The machine does not drive.	<ol style="list-style-type: none"> <li>1. The traction belt is worn, loose, or broken.</li> <li>2. The traction belt is off of the pulley.</li> </ol>	<ol style="list-style-type: none"> <li>1. Adjust the belt tension or replace the belt.</li> <li>2. Contact an Authorized Service Dealer.</li> </ol>





LCE

# The Toro Total Coverage Guarantee

## A Limited Warranty

### Conditions and Products Covered

The Toro Company and its affiliate, Toro Warranty Company, pursuant to an agreement between them, jointly promise to repair the listed Toro Products if defective in materials or workmanship. The following time periods apply from the date of purchase:

<u>Products</u>	<u>Warranty Period</u>
• All Products	1 year
• All Spindles	2 years parts and labor; third year, parts only
• Engines/Hydraulic Systems* on the following: Outfront and Mid-Mount Z's ProLine Mid-Size Mowers Groundsmaster® Riding Mowers Backpack Blowers	2 years
• Deck Shells (36"-72") on the following: ProLine Mid-Size Mowers Mid-Mount Z's	2 years
• Electric Clutch on 200 Series Mid-Mount Z's	2 years

This warranty includes the cost of parts and labor, but you must pay transportation costs.

This warranty applies to:

- Outfront and Mid-Mount Z's
- ProLine Mid-Size Mowers
- Groundsmaster Riding Mowers
- Turf Maintenance Equipment
- Debris Management Equipment

\* Some engines used on Toro LCE Products are warranted by the engine manufacturer.

### Instructions for Obtaining Warranty Service

If you think that your Toro Product contains a defect in materials or workmanship, follow this procedure:

1. Contact any Toro Authorized or Master Service Dealer to arrange service at their dealership. To locate a dealer convenient to you, access our website at [www.Toro.com](http://www.Toro.com). U.S. Customers may also call 800-348-2424.
2. Bring the product and your proof of purchase (sales receipt) to the Service Dealer.

If for any reason you are dissatisfied with the Service Dealer's analysis or with the assistance provided, contact us at:

LCB Customer Service Department  
Toro Warranty Company  
8111 Lyndale Avenue South  
Bloomington, MN 55420-1196  
888-577-7466 (U.S. customers)  
877-484-9255 (Canada customers)

### Countries Other than the United States or Canada

Customers who have purchased Toro products exported from the United States or Canada should contact their Toro Distributor (Dealer) to obtain guarantee policies for your country, province, or state. If for any reason you are dissatisfied with your Distributor's service or have difficulty obtaining guarantee information, contact the Toro importer. If all other remedies fail, you may contact us at Toro Warranty Company.

### Owner Responsibilities

You must maintain your Toro Product by following the maintenance procedures described in the operator's manual. Such routine maintenance, whether performed by a dealer or by you, is at your expense.

### Items and Conditions Not Covered

There is no other express warranty except for special emission system coverage on some products. This express warranty does not cover the following:

- Cost of regular maintenance service or parts, such as filters, fuel, lubricants, tune-up parts, blade sharpening, brake and clutch adjustments.
- Any product or part which has been altered or misused or required replacement or repair due to normal wear, accidents, or lack of proper maintenance.
- Repairs necessary due to improper fuel, contaminants in the fuel system, or failure to properly prepare the fuel system prior to any period of non-use over three months.
- Pickup and delivery charges.

All repairs covered by this warranty must be performed by an Authorized Toro Service Dealer using Toro approved replacement parts.

### General Conditions

Repair by an Authorized Toro Service Dealer is your sole remedy under this warranty.

Neither The Toro Company nor Toro Warranty Company is liable for indirect, incidental or consequential damages in connection with the use of the Toro Products covered by this warranty, including any cost or expense of providing substitute equipment or service during reasonable periods of malfunction or non-use pending completion of repairs under this warranty.

Some states do not allow exclusions of incidental or consequential damages, or limitations on how long an implied warranty lasts, so the above exclusions and limitations may not apply to you.

All implied warranties of merchantability (that the product is fit for ordinary use) and fitness for use (that the product is fit for a particular purpose) are limited to the duration of the express warranty.

This warranty gives you specific legal rights, and you may also have other rights which vary from state to state.