



# Tow Behind Trailer

## Trans Pro 100

Model No. 04240—220000001 and Up

## Parts Catalog

---

### Ordering Replacement Parts

To order replacement parts, please supply: the part number, the quantity, and the description of each part desired.

### Understanding Reference Numbers

Each identified part in an illustration has a reference number. The reference number for a part also appears in the parts list, along with other information about the part.

This catalog uses two special reference number formats, one to indicate parts in a service assembly and another to indicate the quantity of a given part in an illustration.

### Service Assembly Reference Numbers

Parts in service assemblies have reference numbers in the form **a:b**. The **a** represents the reference number of the entire service assembly and the **b** represents a sequential number unique to each part within the service assembly.

For example, a wheel assembly might be identified by reference number **6**, the tire by **6:1**, the valve by **6:2**, and the wheel by **6:3**. When you order the assembly identified by reference number **6**, you receive all parts identified by reference numbers **6:1**, **6:2**, and **6:3**. However, you may also order any part individually.

Reference numbers of this type appear in illustrations and in part lists.

### Reference Numbers Indicating Quantity

In an illustration, if a reference number indicates more than one part, the reference number has the form **nX y**. The **n** represents the quantity of the part, the **X** is the multiplication symbol, and the **y** represents the reference number.

For example, in an illustration, the reference number **2X 37** means that two of the parts identified by reference number **37** are indicated.

## Contents

<b>Description</b>	<b>Page</b>	<b>Description</b>	<b>Page</b>
Trailer Bed Assembly .....	3	Ramp Assembly .....	5
Tongue Assembly .....	4	Hub and Wheel Assembly .....	6

## Accessories

<b>Description</b>	<b>Model / Part No.</b>	<b>Description</b>	<b>Model / Part No.</b>
High Ramp Conversion Kit .....	04241	18" Conversion Kit .....	04242

## Part Description Abbreviations

Part descriptions in this catalog may include the following abbreviations.

<b>Abbreviation</b>	<b>Meaning</b>	<b>Abbreviation</b>	<b>Meaning</b>
AR .....	as required	HYD .....	hydraulic
ASM .....	assembly	INC .....	incorporated
CARR .....	carriage	LH .....	left hand
DEG .....	degrees	NI .....	nylon insert
FH .....	flat head	PPH .....	Phillips pan head
GA .....	gauge	PTH .....	Phillips truss head
HF .....	hex flange	PTO .....	power take off
HH .....	hex head	RH .....	right hand
HHF .....	hex head flange	SFH .....	slotted fillister head
HLH .....	hex lag head	SHH .....	slotted hex head
HJ .....	hex jam	SQH .....	square head
HOC .....	height-of-cut	SHWH .....	slotted hex washer head
HS .....	hex socket	SPH .....	slotted pan head
HSBH .....	hex socket button head	SRH .....	slotted round head
HSFH .....	hex socket flat head	STD .....	standard
HSH .....	hex socket head	TAP .....	self tapping
HWH .....	hex washer head	TTH .....	Torx truss head
HWHTF .....	hex washer head thread forming	WH .....	wing head

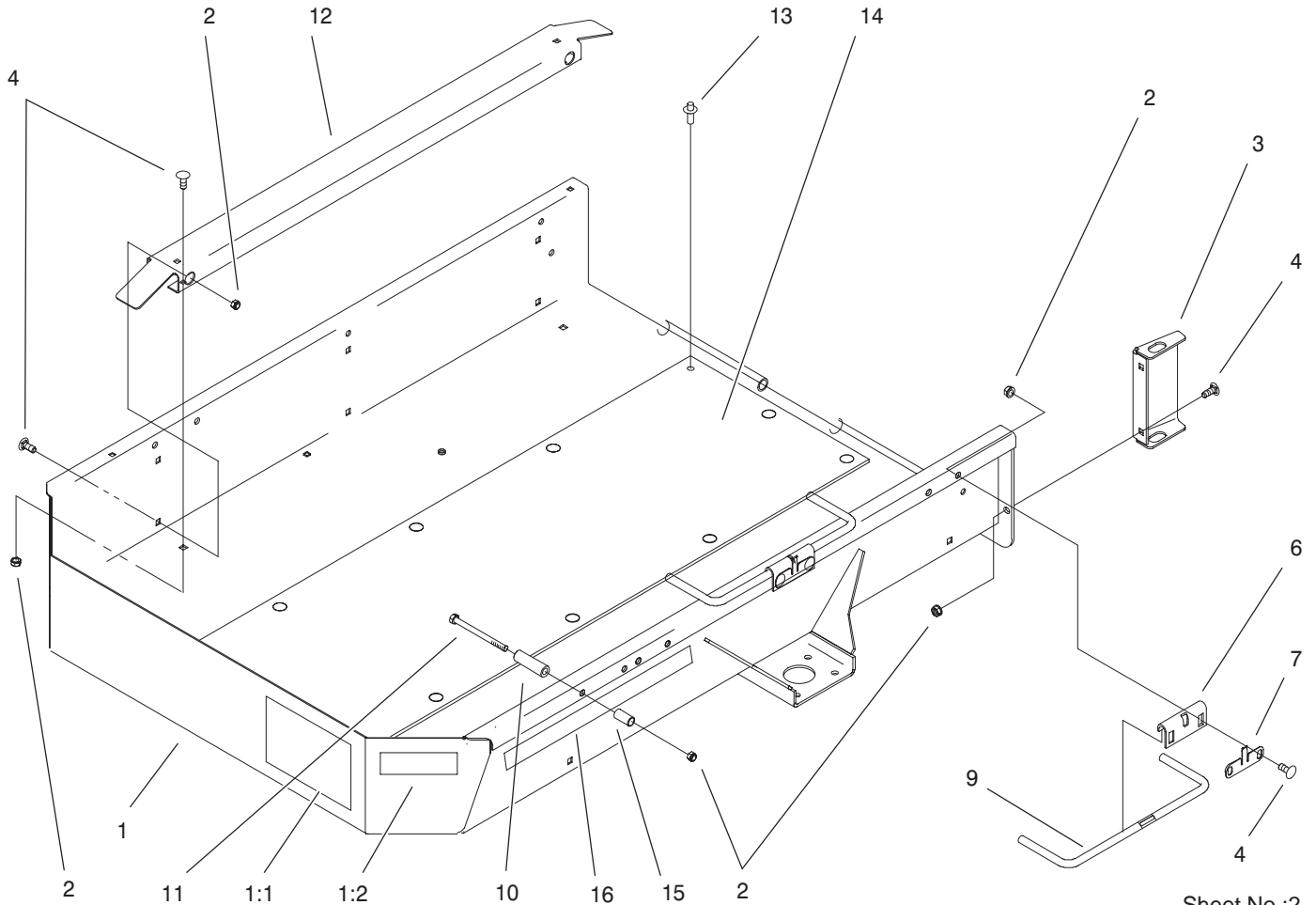

Sheet No.:2

# Trailer Bed Assembly

Ref. No.	Part No.	Qty.	Description
1	104-0545	1	Bed ASM
1:1	98-8688	1	Decal-Caution
1:2	98-8687	1	Decal-Pressure, Air
2	32128-36	22	Nut-HF
3	98-8761-01	2	Guide-Wheel
4	3231-21	20	Screw-CARR
6	105-5395	4	Bracket-Rod
7	98-8697	4	Spring-Latch
9	105-5394	4	Rod-Wheel, Large
10	98-8756	2	Spacer-Stop
11	323-38	2	Screw-HH
12	98-8677-01	2	Insert-Standard
13	105-5392	12	Rivet-Drive
14	98-8776	1	Mat-Bed
15	98-8777	2	Spacer
16	98-8694	2	Decal-Trans Pro 100

Ref. No.	Part No.	Qty.	Description

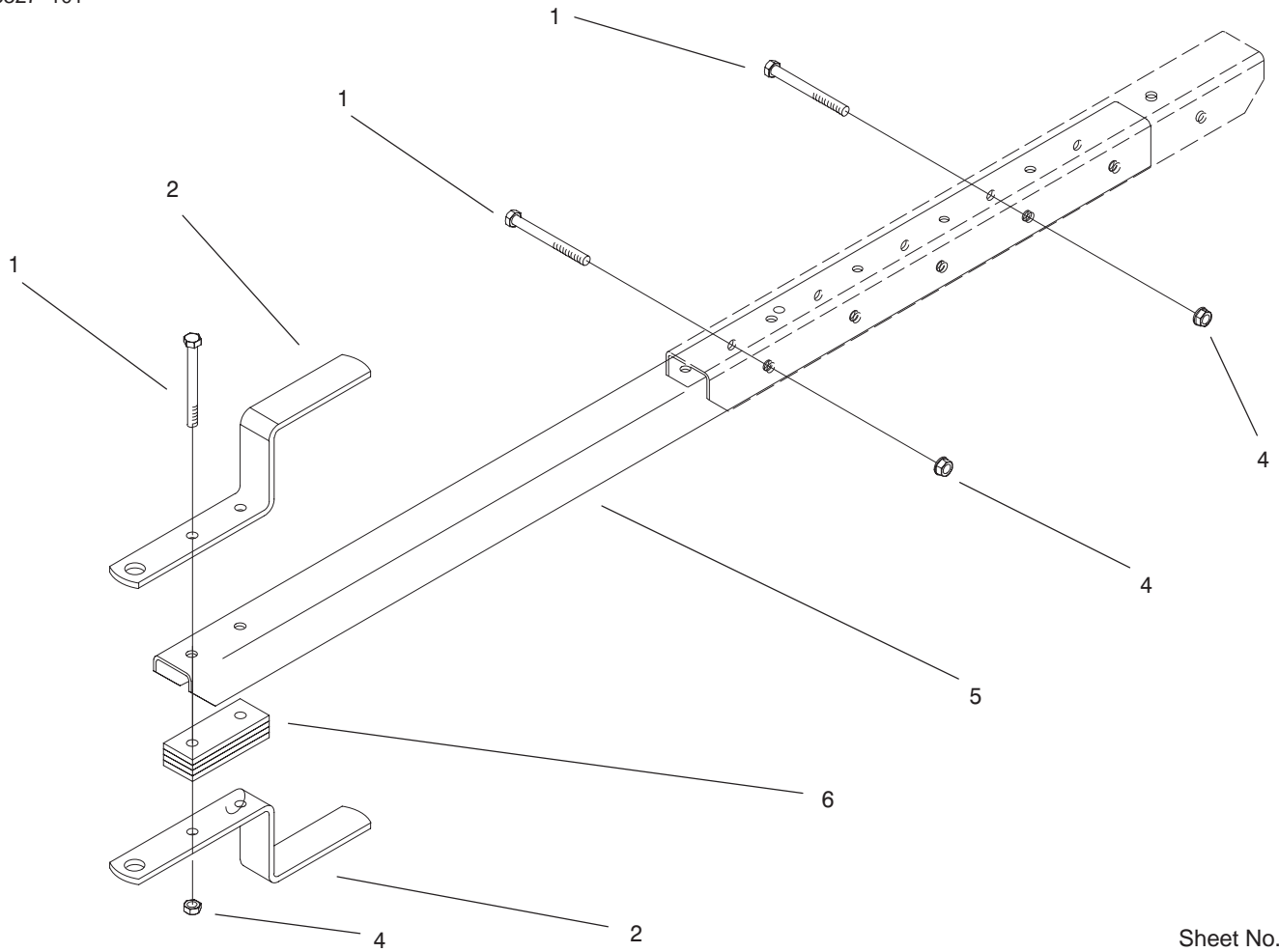

Sheet No.:3

## Tongue Assembly

Ref. No.	Part No.	Qty.	Description
1	323-13	4	Screw-HH
2	98-8779-01	2	Hitch-Trailer
4	32128-36	4	Nut-HF
5	99-4543-01	1	Tongue-Trailer
6	98-8780	4	Spacer-Hitch

Ref. No.	Part No.	Qty.	Description

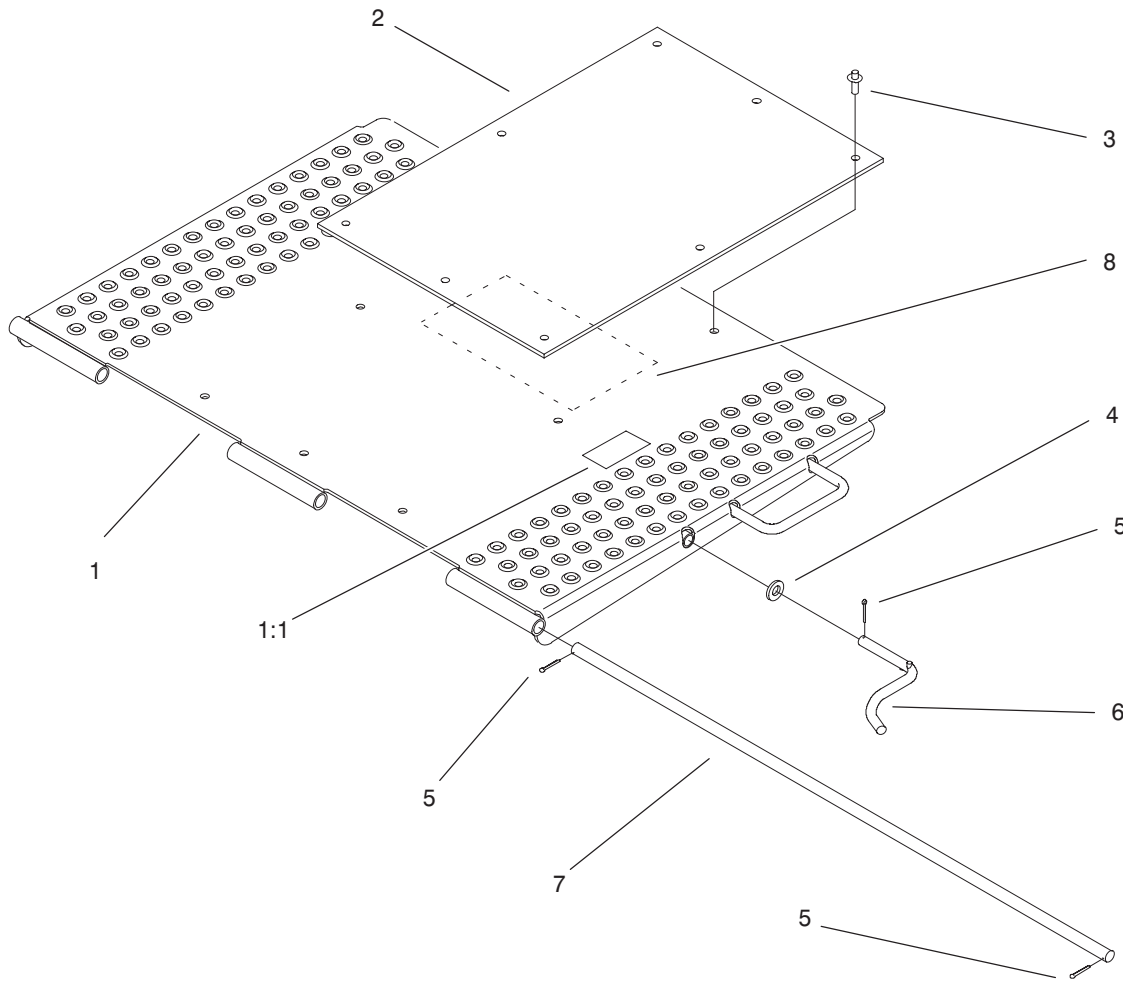

Sheet No.:4

## Ramp Assembly

Ref. No.	Part No.	Qty.	Description
1	104-0546	1	Ramp ASM
1:1	98-8676	1	Decal-Caution
2	98-8775	1	Mat-Ramp
3	105-5392	8	Rivet-Drive
4	3256-26	1	Washer-Flat
5	3272-7	3	Pin-Cotter
6	98-8754	1	Latch-Ramp
7	98-8759	1	Hinge-Rod
8	66-1210	1	Decal-Toro

Ref. No.	Part No.	Qty.	Description

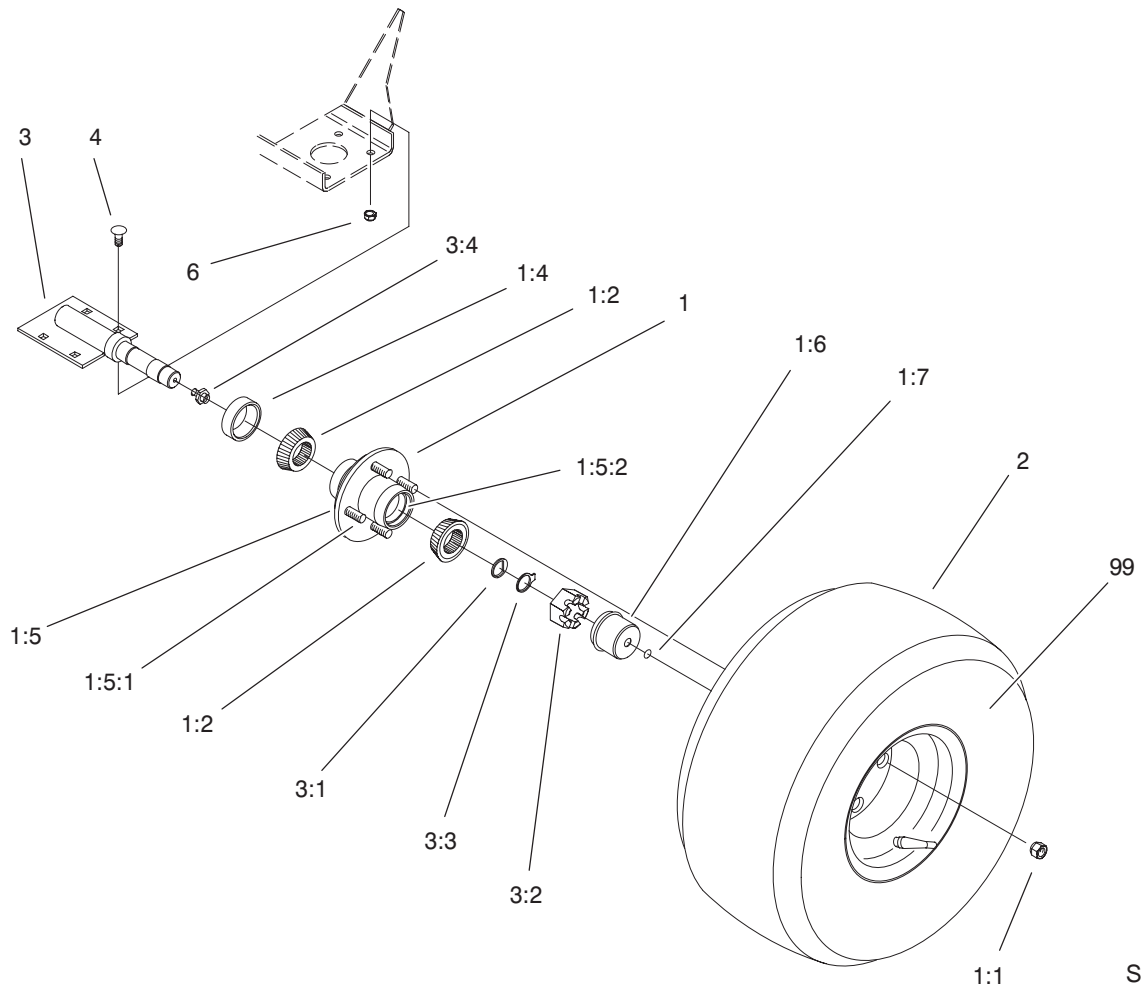

Sheet No.:5

## Hub and Wheel Assembly

Ref. No.	Part No.	Qty.	Description
1	98-8690	2	Hub ASM
1:1	242-50	4	Nut-Lug
1:2	99-4501	2	Cone-Bearing
1:4	99-4500	1	Seal-Grease
1:5	99-4502	1	Hub
1:5:1	99-4512	4	Stud-In, Screw
1:5:2	99-4511	2	Race-Bearing
1:6	99-4503	1	Cap-Grease
1:7	99-4504	1	Plug-Cap, Grease
2	98-8691	2	Wheel ASM
3	98-8766-01	2	Axle
3:1	99-4505	1	Washer
3:2	99-4508	1	Nut-Castle
3:3	99-4509	1	Washer-Tang
3:4	302-58	1	Fitting-Grease
4	3231-22	8	Screw-CARR
6	32128-36	8	Nut-HF
99	232-47	2	Tube

Ref. No.	Part No.	Qty.	Description

# Maintenance Record

Date								

