

TURF TRACER® X-SERIES

**To Fit Turf Tracer® X-Series "N0" Models
413,950,474 & Higher**
Part No. 4506-289 Rev. A

Operator's Manual

⚠ WARNING

**CALIFORNIA
Proposition 65 Warning**

Use of this product may cause exposure to chemicals known to the State of California to cause cancer, birth defects, or other reproductive harm.

Exmark reserves the right to make changes or add improvements to its products at any time without incurring any obligation to make such changes to products manufactured previously. Exmark, or its distributors and dealers, accept no responsibility for variations which may be evident in the actual specifications of its products and the statements and descriptions contained in this publication.

Introduction

CONGRATULATIONS on the purchase of your Exmark StandOn. This product has been carefully designed and manufactured to give you a maximum amount of dependability and years of trouble-free operation.

This accessory is intended to be used with large walk-behind mowers designed by Exmark. Using this product for purposes other than its intended use could prove dangerous to you and bystanders.

This manual contains operating, maintenance, adjustment, and safety instructions for your Exmark StandOn.

BEFORE OPERATING YOUR STANDON, CAREFULLY READ THIS MANUAL IN ITS ENTIRETY.

By following the operating, maintenance, and safety instructions, you will prolong the life of your StandOn, maintain its maximum efficiency, and promote safe operation.

To maximize safety, performance, and proper operation of this machine, it is essential that all operators carefully read and fully understand the contents of the Operator's manual provided with the product. Failure to comply with the operating instructions or receive proper training may result in injury. Go to <https://www.Exmark.com> for additional safe operation information, such as safety tips, training materials, and Operator's manuals.

If additional information is needed, or should you require trained mechanic service, contact your authorized Exmark equipment dealer or distributor.

All Exmark equipment dealers and distributors are kept informed of the latest methods of servicing and are equipped to provide prompt and efficient service in the field or at their service stations. They carry ample stock of service parts or can secure them promptly for you from the factory.

All Exmark parts are thoroughly tested and inspected before leaving the factory, however, attention is required on your part if you are to obtain the fullest measure of satisfaction and performance.

Whenever you need service, genuine Exmark parts, or additional information, contact an Authorized Service Dealer or Exmark Customer Service and have the model and serial numbers of your product ready.

Contents

Introduction	3
Safety	5
Safety Alert Symbol.....	5
General Safety.....	5
Safety and Instructional Decals	6
Specifications	7
Systems.....	7
Dimensions.....	7
Setup	8
Operation	10
Before Operation	10
Operating Instructions	10
During Operation Safety.....	10
After Operation.....	11
Transporting	11
Maintenance	13
Maintenance Safety.....	13
Recommended Maintenance Schedule(s)	13
Periodic Maintenance	13
Inspect StandOn	13
Check StandOn for Buildup.....	14
Lubricate Grease Fittings.....	14
Lubricate Caster Wheel Hubs	14
Adjustments	15
Tire Adjustment.....	15
California Proposition 65 Warning Information	16

Safety

Safety Alert Symbol

This Safety Alert Symbol (Figure 1) is used both in this manual and on the machine to identify important safety messages which must be followed to avoid accidents.

This symbol means: **ATTENTION! BECOME ALERT! YOUR SAFETY IS INVOLVED!**



Figure 1
Safety Alert Symbol

g000502

The safety alert symbol appears above information which alerts you to unsafe actions or situations and will be followed by the word **DANGER**, **WARNING**, or **CAUTION**.

DANGER: Indicates an imminently hazardous situation which, if not avoided, **Will** result in death or serious injury.

WARNING: Indicates a potentially hazardous situation which, if not avoided, **Could** result in death or serious injury.

CAUTION: Indicates a potentially hazardous situation which, if not avoided, **May** result in minor or moderate injury.

This manual uses two other words to highlight information. **Important** calls attention to special mechanical information and **Note** emphasizes general information worthy of special attention.

General Safety

This machine that the StandOn attaches to is capable of amputating hands and feet and of throwing objects. Always follow all safety instructions to avoid serious personal injury or death.

- Read, understand, and follow all instructions and warnings in the mower and StandOn Operator's Manuals and on the machine, engine, and attachments. All operators and mechanics should be trained. If the operator(s) or mechanic(s) can not read this manual, it is the owner's responsibility to explain this material to them; other languages may be available on our website.
- Only allow trained, responsible, and physically capable operators that are familiar with the safe operation, operator controls, and safety signs and instructions to operate the machine. Never let children or untrained people operate or service the equipment. Local regulations may restrict the age of the operator.
- Do Not operate the machine near drop-offs, ditches, embankments, water, or other hazards.
- Keep bystanders and children out of the operating area.
- Do Not put your hands or feet near moving parts.
- Do Not operate the machine without all safety shields, guards, switches, and other devices in place and in proper working condition.
- Park machine on level ground, disengage drives, set parking brake, stop engine, remove key, or disconnect spark plug wire. Wait for all moving parts to stop before leaving the operator's position. Allow the machine to cool before servicing, adjusting, fueling, cleaning, or storing.

Safety

Safety and Instructional Decals

- Keep all safety signs legible. Remove all grease, dirt and debris from safety signs and instructional labels.
- Replace all worn, damaged, or missing safety signs.
- When replacement components are installed, be sure that current safety signs are affixed to the replaced components.
- If an attachment or accessory has been installed, make sure current safety signs are visible.
- New safety signs may be obtained from your authorized Exmark equipment dealer or distributor or from Exmark Mfg. Co. Inc.
- Safety signs may be affixed by peeling off the backing to expose the adhesive surface. Apply only to a clean, dry surface. Smooth to remove any air bubbles.
- Familiarize yourself with the following safety signs and instruction labels. They are critical to the safe operation of your Exmark commercial mower.

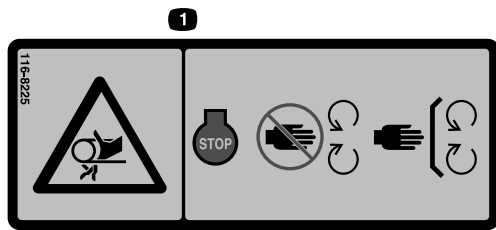

116-8225

decal116-8225

1. Entanglement hazard—Stop the engine before reaching underneath; stay away from moving parts; keep all guards in place.

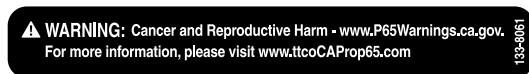

133-8061

decal133-8061

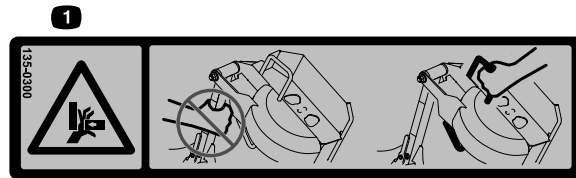

135-0300

decal135-0300

1. Pinch point hazard—Do Not use drawbar to lift StandOn. Only use platform side handles to lift and rotate StandOn.

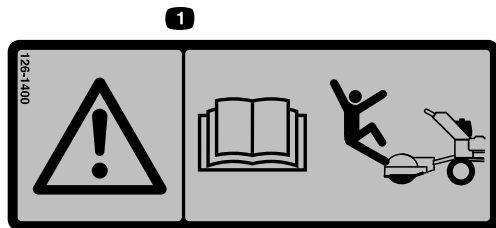

126-1400

decal126-1400

1. Warning—Read the Operator's manual. Use only Exmark riding attachments. Use of other riding attachments may create a hazardous condition resulting in injury.

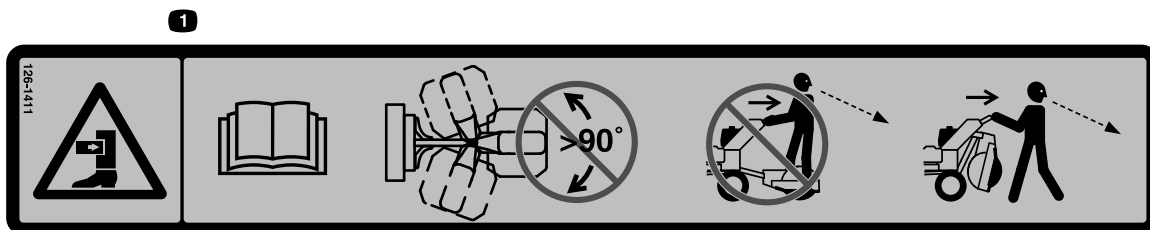

126-1411

decal126-1411

1. Crushing hazard of sulky — read the Operator's manual; Do Not allow sulky to rotate beyond 90 degrees; dismount sulky and place in transport position, if available, before operating in reverse.

Specifications

Systems

Tire

	Tread	Size
Semi-Pneumatic	Smooth	11 x 4.00-5

For operators over 250 lb (113 kg), it is recommended to use pneumatic tire assembly P/N 103-3798.

Dimensions

Overall Width:

18.5 inches (47.0 cm)

Overall Length:

35.4 inches (89.9 cm)

Overall Height:

14.6 inches (37.1 cm)

Weight:

50 lb (23 kg)

Setup

Setup

Item	Quantity	Description
1	4	Nut, Nyloc 3/8-16 Flg
2	2	Plate, Back-Up
3	1	Pin-Lynch
4	4	Screw, HH 3/8-16 x 1 1/4
5	1	Asm-Mount Plate W/Decals
6	1	Asm-Drawbar W/Brgs and Decal
7	1	Cover-Dust

Item	Quantity	Description
8	1	Screw-HH 1/2-13 x 5
9	1	Nut-Nyloc 1/2-13
10	1	Asm-Sulky Frame W/Decals
11	1	Pin-Pivot
12	2	Washer-Spring Disc
13*	2	Decals-Replacement

*Not shown in illustration

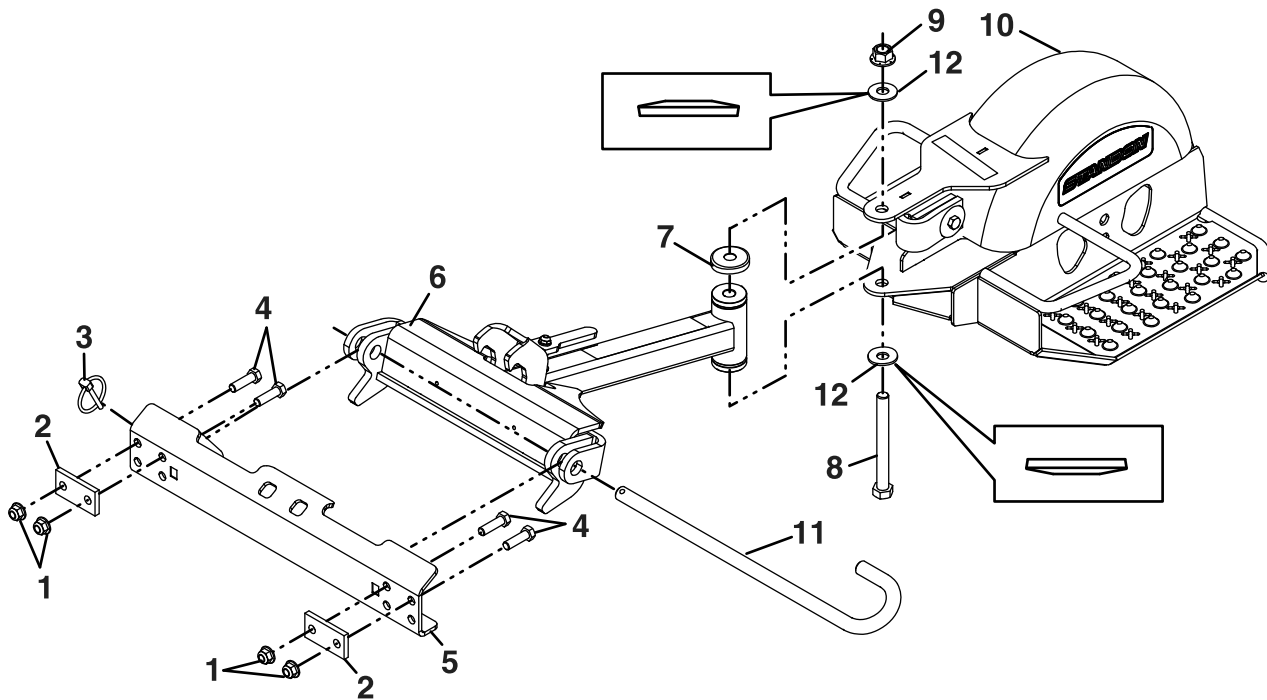

Figure 2

g192307

Installing the Mount Plate:

Align the mount plate to the rear surface of the engine deck.

Install the mount plate to the engine deck using four 3/8-16 x 1 1/4 inch hex screws, two backup plates, and four 3/8-16 inch nyloc nuts as shown in Figure 3.

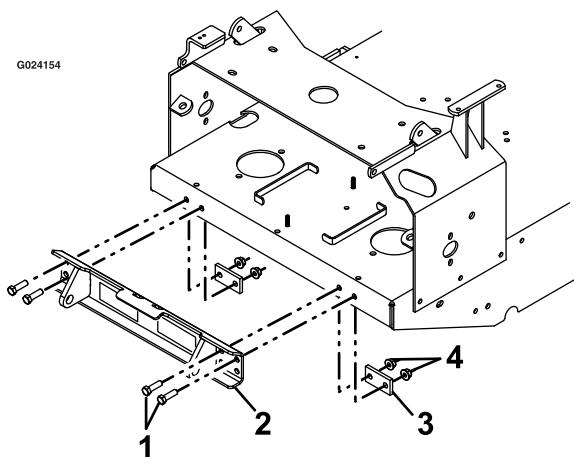

Figure 3

- | | |
|--------------------------------------|---------------------------|
| 1. 3/8-16 x 1 1/4 inch hex capscrews | 3. Backup plates |
| 2. Mount plate | 4. 3/8-16 inch nyloc nuts |

Mounting the Drawbar and Platform

1. Locate the drawbar assembly; remove and retain the 1/2-13 x 5 inch hex screw, spring disc washers, and 1/2 inch hex flanged nyloc nut from the pivot hub.
2. Align the sulky frame assembly with the drawbar assembly. Reinstall the 1/2-13 x 5 inch hex screw, spring disc washers, and 1/2 inch hex flange nyloc nut, removed in step 1, as shown in Figure 4. Torque nut to 90 ft-lb (122 N-m).

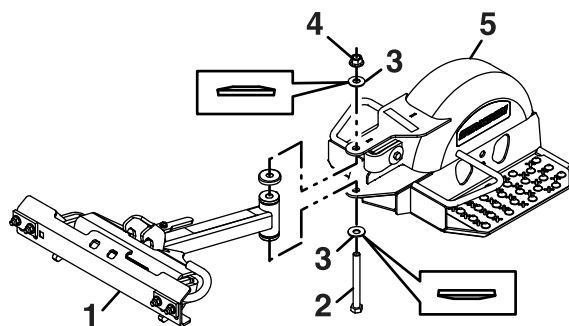

Figure 4

- | | |
|------------------------------|----------------------------------|
| 1. Drawbar assembly | 4. 1/2 inch hex flange nyloc nut |
| 2. 1/2-13 x 5 inch hex screw | 5. Sulky frame assembly |
| 3. Spring disc washers | |

3. Remove the lynch pin and pivot pin from the mount plate. Align the drawbar assembly with the mount plate as shown in Figure 5.

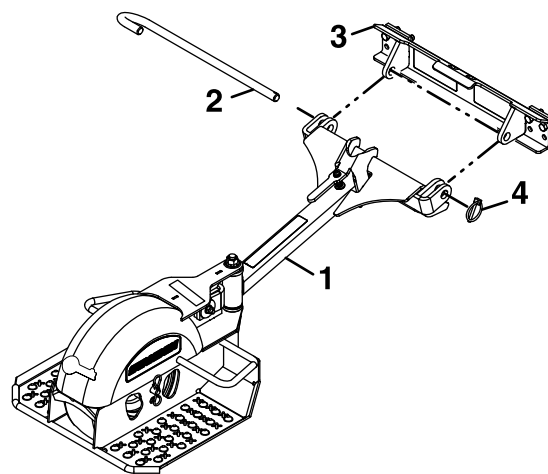

Figure 5

- | | |
|---------------------|----------------|
| 1. Drawbar assembly | 3. Mount plate |
| 2. Pivot pin | 4. Lynch pin |

4. Install the pivot pin through the holes in the drawbar and mount plate and retain with the lynch pin.

Operation

Note: Determine the left and right sides of the machine from the normal operating position.

Before Operation

Before Operation Safety

- Do Not modify the StandOn.
- Evaluate the terrain to determine what accessories and attachments are needed to properly and safely perform the job. Only use accessories and attachments approved by Exmark.
- Inspect the area where the machine is to be used and remove all rocks, toys, sticks, wires, bones, and other foreign objects. These can be thrown or interfere with the operation of the machine and may cause personal injury to the operator or bystanders.
- The machine that the StandOn attaches to was designed for one operator only. Do Not carry passengers.
- Wear appropriate personal protective equipment such as safety glasses, long pants, substantial slip-resistant footwear, and hearing protection. Tie back long hair and avoid loose clothing and loose jewelry which may get tangled in moving parts.
- The machine that the StandOn attaches to produces sound levels in excess of 85 dBA at the operator's ear and can cause hearing loss through extended periods of exposure. Wear hearing protection when operating this machine.
- Do Not operate the mower when people, especially children, or pets are in the area. Shut off the machine and attachment(s) if anyone enters the area.
- Do Not operate the machine without the entire grass collection system, discharge deflector, or other safety devices in place and in proper working condition. Grass catcher components are subject to wear, damage and deterioration, which could expose moving parts or allow objects to be thrown. Frequently check for worn or deteriorating components and replace them with the manufacturer's recommended parts when necessary.

- Make sure you understand the controls, their locations, their functions, and their safety requirements.
- Practice operating the machine without the StandOn until familiar with the controls.
- Practice operating the machine with the StandOn attached on large, open, level terrain with no obstacles present before use. The StandOn will affect the machine operation, especially on slopes, when turning, and when stopping.
- Ensure the drawbar assembly is securely connected to the mount plate.
- For operators over 250 lb (113 kg), it is recommended to use pneumatic tire assembly, P/N 103-3798.

Operating Instructions

During Operation Safety

General Safety

The operator must use their full attention when operating the machine. **Do Not** engage in any activity that causes distractions; otherwise, injury or property damage may occur.

- Operate the machine only in good visibility and appropriate weather conditions. Do Not operate the machine when there is the risk of lightning.
- Keep away from holes, ruts, bumps, rocks, and other hidden hazards. Use care when approaching blind corners, shrubs, trees, tall grass or other objects that may hide obstacles or obscure vision. Uneven terrain could overturn the machine.
- Do Not operate the machine without all safety shields, guards, switches, and other devices in place and in proper working condition.
- Keep your hands and feet away from the moving parts. Keep clear of the discharge opening.
- Do Not mow with the discharge deflector raised, removed, or altered unless there is a grass-collection system or mulch kit in place and working properly.

Operating

⚠ DANGER

If the StandOn rotates beyond 90°, there is a potential crushing hazard. Rapid rotation beyond 90° can cause the StandOn to jackknife into the mower engine deck and cause serious injury.

- Dismount the StandOn and place in transport position before operating in reverse.
 - Reduce speed when making sharp turns and operating on slopes.
1. Use care when turning to ensure that you Do Not swing yourself and the sulky into obstacles.
 2. When turning, lean forward and toward the direction of the turn to help in keeping balance.

After Operation

General Safety

- Park machine on level ground, disengage drives, set parking brake, stop engine, remove key or disconnect spark plug wire. Wait for all movement to stop and allow the machine to cool before adjusting, cleaning, repairing, or storing. Never allow untrained personnel to service machine.
- Clean the machine as stated in the Maintenance section.
- Frequently check for worn or deteriorating components that could create a hazard. Tighten loose hardware.

Transporting

Transporting the StandOn

Use the platform side handles to lift and rotate the StandOn into transport position when loading a machine on a trailer, unloading a machine from a trailer, or operating in reverse.

Important: Do Not use the drawbar to lift the StandOn.

⚠ CAUTION

Fingers may be pinched when lifting and rotating the platform.

Always use platform side handles to lift and rotate the StandOn.

- **Placing into Transport Position:**
 1. Using one of the platform side handles, slightly lift the StandOn.

Operation

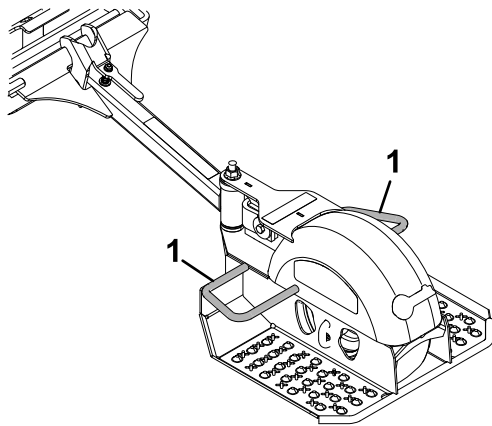

Figure 6

g192304

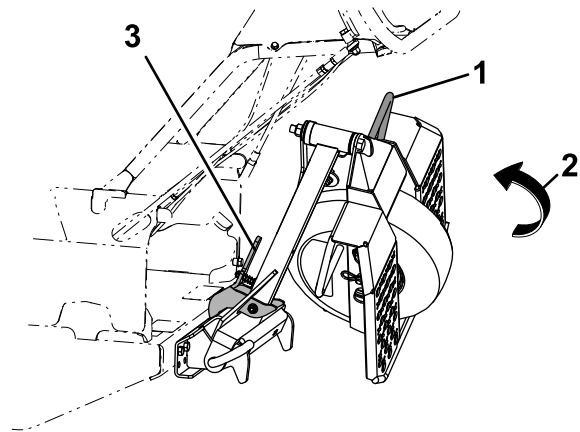

Figure 8

g192305

1. Platform side handles

2. Slowly and carefully rotate the StandOn until it contacts the drawbar (see Figure 7).

If holding the left platform side handle, rotate the StandOn counterclockwise; using the right platform side handle, rotate it clockwise.

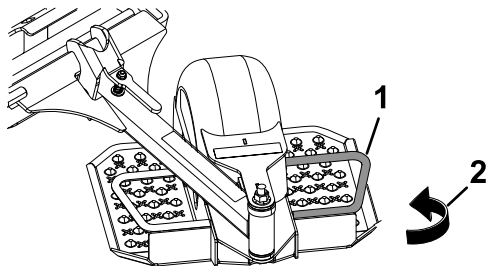

Figure 7

g192306

1. Left platform side handle
2. Rotate counterclockwise

3. Slowly and carefully lift the StandOn until the latch locks into place.

1. Left platform side handle
2. Lift up
3. Latch

- **Lowering the StandOn into Operating Position:**

1. Firmly hold the platform side handle and lift slightly (reference Figure 8).
2. Squeeze the latch to release the StandOn and slowly and carefully lower it to the ground.

Maintenance

Note: Determine the left and right sides of the machine from the normal operating position.

Maintenance Safety

- Park machine on level ground, disengage drives, set parking brake, stop engine, and remove key. Wait for all moving parts to stop before leaving the operator's position. Allow the machine to cool before servicing, adjusting, fueling, cleaning, or storing.

⚠ WARNING

The engine can become very hot. Touching a hot engine can cause severe burns.

Allow the engine to cool completely before service or making repairs around the engine area.

- If you leave the key in the switch, someone could accidentally start the engine and seriously injure you or other bystanders. Remove the key from the switch before you perform any maintenance.
- Never allow untrained personnel to service machine.
- Keep all guards, shields, switches, and all safety devices in place and in proper working condition. Frequently check for worn or deteriorating components and replace them with genuine Exmark parts when necessary.

⚠ WARNING

Removal or modification of original equipment, parts and/or accessories may alter the warranty, controllability, and safety of the machine. Unauthorized modifications to the original equipment or failure to use original Exmark parts could lead to serious injury or death. Unauthorized changes to the machine, engine, fuel or venting system, may violate applicable safety standards such as: ANSI, OSHA and NFPA and/or government regulations such as EPA and CARB.

- Keep your hands and feet away from moving parts or hot surfaces. If possible, Do Not make adjustments with the engine running.

⚠ WARNING

Contact with moving parts or hot surfaces may cause personal injury.

Keep your fingers, hands, and clothing clear of rotating components and hot surfaces.

- Keep all parts in good working condition and all hardware tightened.

Recommended Maintenance Schedule(s)

Maintenance Service Interval	Maintenance Procedure
Before each use or daily	<ul style="list-style-type: none"> • Inspect the StandOn. • Check for dirt/mud buildup between tire and fender.
Yearly	<ul style="list-style-type: none"> • Grease caster wheel hub. • Lubricate the caster wheel hubs.

Periodic Maintenance

Inspect StandOn

Service Interval: Before each use or daily

1. Stop engine, wait for all moving parts to stop, and remove key. Engage parking brake.

2. Inspect for loose hardware. Tighten any loose hardware.
3. Inspect for wear or damage daily. Replace or repair worn parts as needed before operating.

Maintenance

Check StandOn for Buildup

Service Interval: Before each use or daily

Check for dirt/mud buildup between tire and fender. Remove buildup before operating.

Note: You can wash the StandOn with mild detergent and water. Do not pressure wash the machine.

Lubricate Grease Fittings

Note: See chart for service intervals.

1. Stop engine, wait for all moving parts to stop, and remove key. Engage parking brake.
2. Lubricate fittings with NLGI grade #2 multi-purpose gun grease.

Refer to the following chart for fitting locations and lubrication schedule.

Lubrication Chart			
Fitting Locations	Initial Pumps	Number of Places	Service Interval
1. Caster Wheel Hub	0	1	Yearly

Lubricate Caster Wheel Hubs

Service Interval: Yearly

1. Stop engine, wait for all moving parts to stop, and remove key. Engage parking brake.

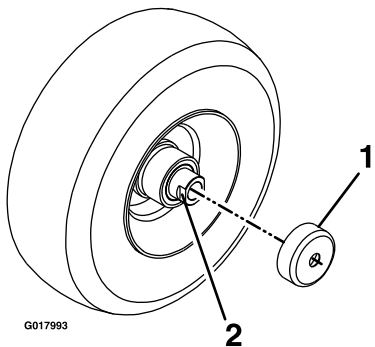

Figure 9

1. Seal guard
2. Spacer nut with wrench flats

4. Remove one of the spacer nuts from the axle assembly in the caster wheel. Note that thread locking adhesive has been applied to lock the spacer nuts to the axle. Remove the axle (with the other spacer nut still assembled to it) from the wheel assembly.
5. Pry out seals, and inspect bearings for wear or damage and replace if necessary.
6. Pack the bearings with a NLGI grade #1 multi-purpose grease.
7. Insert one bearing, one new seal into the wheel.

Note: Seals (Exmark PN 103-0063) must be replaced.

8. If the axle assembly has had both spacer nuts removed (or broken loose), apply a thread locking adhesive to one spacer nut and thread onto the axle with the wrench flats facing outward. Do Not thread spacer nut all of the way onto the end of the axle. Leave approximately 1/8 inch (3 mm) from the outer surface of the spacer nut to the end of the axle inside the nut.
9. Insert the assembled nut and axle into the wheel on the side of the wheel with the new seal and bearing.
10. With the open end of the wheel facing up, fill the area inside the wheel around the axle full of NLGI grade #1 multi-purpose grease.
11. Insert the second bearing and new seal into the wheel.
12. Apply a thread locking adhesive to the second spacer nut and thread onto the axle with the wrench flats facing outward.
13. Torque the nut to 75-80 in-lb (8-9 N-m), loosen, then re-torque to 20-25 in-lb (2-3 N-m). Make sure axle does not extend beyond either nut.
14. Reinstall the seal guards over the wheel hub and insert wheel into the sulky frame. Reinstall caster pin and bow tie cotter pin.

Important: To prevent seal and bearing damage, check the bearing adjustment often. Spin the caster tire. The tire should not spin freely (more than 1 or 2 revolutions) or have any side play. If the wheel spins freely, adjust torque on spacer nut until there is a slight amount of drag. Reapply thread locking adhesive.

2. Remove the caster wheel from the sulky frame.
3. Remove seal guards from the wheel hub.

Adjustments

Tire Adjustment

To obtain additional ground clearance, the platform wheel can be repositioned (see Figure 10).

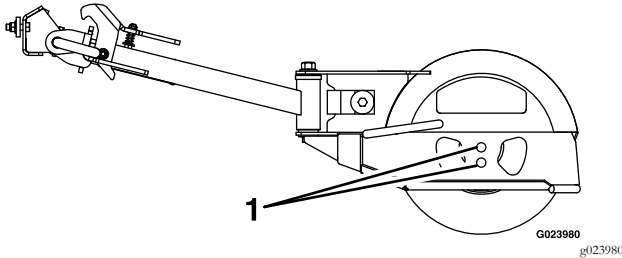

Figure 10

1. Wheel can be mounted in either hole for height adjustment

Note: To achieve more ground clearance for higher cutting heights, raise the platform by using the lower wheel adjustment hole.

California Proposition 65 Warning Information

What is this warning?

You may see a product for sale that has a warning label like the following:



WARNING: Cancer and Reproductive Harm—www.p65Warnings.ca.gov.

What is Prop 65?

Prop 65 applies to any company operating in California, selling products in California, or manufacturing products that may be sold in or brought into California. It mandates that the Governor of California maintain and publish a list of chemicals known to cause cancer, birth defects, and/or other reproductive harm. The list, which is updated annually, includes hundreds of chemicals found in many everyday items. The purpose of Prop 65 is to inform the public about exposure to these chemicals.

Prop 65 does not ban the sale of products containing these chemicals but instead requires warnings on any product, product packaging, or literature with the product. Moreover, a Prop 65 warning does not mean that a product is in violation of any product safety standards or requirements. In fact, the California government has clarified that a Prop 65 warning “is not the same as a regulatory decision that a product is ‘safe’ or ‘unsafe.’” Many of these chemicals have been used in everyday products for years without documented harm. For more information, go to <https://oag.ca.gov/prop65/faqs-view-all>.

A Prop 65 warning means that a company has either (1) evaluated the exposure and has concluded that it exceeds the “no significant risk level”; or (2) has chosen to provide a warning based on its understanding about the presence of a listed chemical without attempting to evaluate the exposure.

Does this law apply everywhere?

Prop 65 warnings are required under California law only. These warnings are seen throughout California in a wide range of settings, including but not limited to restaurants, grocery stores, hotels, schools, and hospitals, and on a wide variety of products. Additionally, some online and mail order retailers provide Prop 65 warnings on their websites or in catalogs.

How do the California warnings compare to federal limits?

Prop 65 standards are often more stringent than federal and international standards. There are various substances that require a Prop 65 warning at levels that are far lower than federal action limits. For example, the Prop 65 standard for warnings for lead is 0.5 µg/day, which is well below the federal and international standards.

Why don't all similar products carry the warning?

- Products sold in California require Prop 65 labelling while similar products sold elsewhere do not.
- A company involved in a Prop 65 lawsuit reaching a settlement may be required to use Prop 65 warnings for its products, but other companies making similar products may have no such requirement.
- The enforcement of Prop 65 is inconsistent.
- Companies may elect not to provide warnings because they conclude that they are not required to do so under Prop 65; a lack of warnings for a product does not mean that the product is free of listed chemicals at similar levels.

Why does Exmark include this warning?

Exmark has chosen to provide consumers with as much information as possible so that they can make informed decisions about the products they buy and use. Exmark provides warnings in certain cases based on its knowledge of the presence of one or more listed chemicals without evaluating the level of exposure, as not all the listed chemicals provide exposure limit requirements. While the exposure from Exmark products may be negligible or well within the “no significant risk” range, out of an abundance of caution, Exmark has elected to provide the Prop 65 warnings. Moreover, if Exmark does not provide these warnings, it could be sued by the State of California or by private parties seeking to enforce Prop 65 and subject to substantial penalties.

Notes:

Notes:

EXMARK ACCESSORIES AND OPTIONS*

MID-MOUNT RIDING ACCESSORIES AND OPTIONS

CUSTOM RIDE SEAT SUSPENSION SYSTEM	OPERATOR CONTROLLED DISCHARGE
FULL SUSPENSION SEAT	SUN SHADE
DECK LIFT ASSIST KIT	TRASH CONTAINER
HITCH KIT	TURF STRIPER
LIGHT KIT	ULTRA VAC COLLECTION SYSTEM
12V POWER PORT	ULTRA VAC QUICK DISPOSAL SYSTEM
MICRO-MULCH SYSTEM	

OUT-FRONT RIDING ACCESSORIES AND OPTIONS

CUSTOM RIDE SEAT SUSPENSION SYSTEM	SNOW BLADE
DUAL-TAIL WHEEL	SNOWBLOWER
FLOOR PAN EXTENDER	SUN SHADE
HITCH KIT	TRASH CONTAINER
LIGHT KIT	ULTRA VAC COLLECTION SYSTEM
MICRO-MULCH SYSTEM	ULTRA VAC QUICK DISPOSAL SYSTEM
ROLL OVER PROTECTION SYSTEM (ROPS)	WEATHER CAB

WALK-BEHIND ACCESSORIES AND OPTIONS

GRASS CATCHER	TURF STRIPER
MICRO-MULCH SYSTEM	STANDON

*Some accessories and options not available for some models.

Place Model No. and Serial No.
Label Here (Included in the Literature
Pack) or Fill in Below

Model No. _____

Serial No. _____

Date Purchased _____

©2022 Exmark Mfg. Co., Inc.
415 Industrial Row
Beatrice, NE 68310
All Rights Reserved

Part No. 4506-289 Rev. A
(402) 223-6300
Printed in the USA

