



# Power Max<sup>®</sup> e26 60V Snowthrower

Model No. 31875—Serial No. 40000000 and Up

## Operator's Manual

# Introduction

This machine is intended to be used by residential homeowners. It is designed primarily for removing snow from paved surfaces, such as driveways and sidewalks, and other surfaces for traffic on residential or commercial properties. It is designed to use Toro 60V lithium-ion battery packs. These battery packs are designed to be charged only by Toro 60V lithium-ion battery chargers. Using these products for purposes other than their intended use could prove dangerous to you and bystanders.

Read this information carefully to learn how to operate and maintain your product properly and to avoid injury and product damage. You are responsible for operating the product properly and safely.

Visit [www.Toro.com](http://www.Toro.com) for product safety and operation training materials, accessory information, help finding a dealer, or to register your product.

Whenever you need service, genuine Toro parts, or additional information, contact an Authorized Service Dealer or Toro Customer Service and have the model and serial numbers of your product ready. [Figure 1](#) identifies the location of the model and serial numbers on the product. Write the numbers in the space provided.

**Important:** With your mobile device, you can scan the QR code on the serial number decal (if equipped) to access warranty, parts, and other product information.

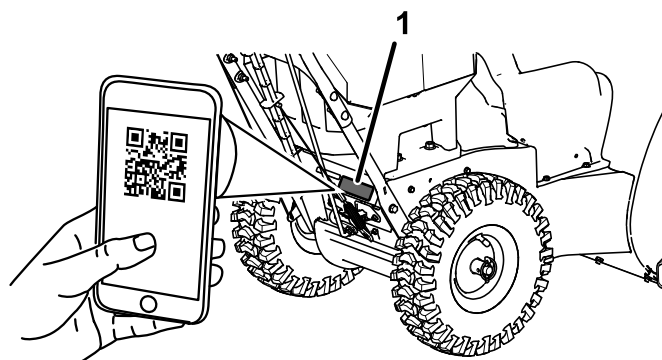

g397375

**Figure 1**

1. Model number, serial number, and QR code location

<p><b>Model No.</b> _____</p> <p><b>Serial No.</b> _____</p>
--



# Safety-Alert Symbol

The safety-alert symbol (Figure 1) shown in this manual and on the machine identifies important safety messages that you must follow to prevent accidents.



**Figure 2**  
Safety-alert symbol

g000502

The safety-alert symbol appears above information that alerts you to unsafe actions or situations and is followed by the word **DANGER**, **WARNING**, or **CAUTION**.

**DANGER** indicates an imminently hazardous situation which, if not avoided, **will** result in death or serious injury.

**WARNING** indicates a potentially hazardous situation which, if not avoided, **could** result in death or serious injury.

**CAUTION** indicates a potentially hazardous situation which, if not avoided, **may** result in minor or moderate injury.

This manual uses two other words to highlight information. **Important** calls attention to special mechanical information and **Note** emphasizes general information worthy of special attention.

This product complies with all relevant European directives; for details, please see the separate product specific Declaration of Conformity (DOC) sheet.

# Contents

Introduction .....	1
Safety-Alert Symbol.....	2
Safety .....	3
Safety and Instructional Decals .....	6
Setup .....	9
1 Mounting the Battery Charger (Optional).....	9
2 Installing the Upper Handle .....	9
3 Installing the Chute .....	10
4 Installing the Traction-Control Linkage .....	10
5 Installing the Chute-Control Rod .....	11
6 Installing the Snow-Cleanout Tool .....	12
7 Checking the Tire Pressure .....	13
8 Checking the Skids and Scraper .....	14
9 Checking the Operation of the Traction Drive .....	14
Product Overview .....	15
Specifications .....	16
Attachments/Accessories .....	16
Operation .....	16
Before Operation .....	16
Installing the Battery Pack .....	16
Checking the State of Charge .....	17
During Operation .....	17
Starting the Machine .....	17
Activating ECO Mode .....	17
Charging the Battery Pack .....	18
Operating the Traction Drive .....	19
Operating the Speed Selector .....	19
Operating the Auger/Impeller Drive.....	19
Operating the Quick Stick®.....	20
Clearing a Clogged Discharge Chute .....	21
Operating Tips .....	21
After Operation .....	22
Shutting Off the Machine .....	22
Removing the Battery Pack from the Machine .....	22
Preventing Freeze-up after Use .....	22
Maintenance .....	23
Recommended Maintenance Schedule(s) .....	23
Preparing for Maintenance .....	23
Checking and Adjusting the Skids and Scraper .....	23
Checking and Adjusting the Traction Cable .....	24
Checking and Adjusting the Auger/Impeller Cable .....	25
Checking the Auger-Gearbox-Oil Level.....	26
Lubricating the Hex Shaft.....	26
Replacing the Drive Belts.....	27
Storage .....	27
Storing the Machine.....	27
Troubleshooting .....	28

# Safety

WARNING—When using an electric machine, always read and follow basic safety warnings and instructions to reduce the risk of fire, electric shock, or injury, including the following:

## READ ALL INSTRUCTIONS

WARNING—When using an electrical machine, basic safety precautions should always be followed to reduce the risk of fire, electric shock, or injury, including the following:

### I. Training

1. The operator of the machine is responsible for any accidents or hazards occurring to others or their property.
2. Read and understand the contents of this *Operator's Manual* before you start the machine. Ensure that everyone using this machine knows how to use it, knows how to shut it off quickly, and understands the warnings.
3. Do not allow children to use or play with the machine, battery pack, or the battery charger; local regulations may restrict the age of the operator.
4. Do not allow children or untrained people to operate or service this device. Allow only people who are responsible, trained, familiar with the instructions, and physically capable to operate or service the device.
5. Before using the machine, battery pack, and battery charger, read all the instructions and cautionary markings on these products.
6. Become familiar with the controls and proper use of the machine, battery pack, and battery charger.

### II. Preparation

1. Keep bystanders and children out of the operating area.
2. Never allow children to operate the machine.
3. Do not operate the machine without all guards and safety devices in place and functioning properly on the machine.
4. Inspect the area where you will use the machine and remove all objects that could interfere with the operation of the machine or that the machine could throw.
5. Use only the battery pack specified by Toro. Using other accessories and attachments may increase the risk of injury and fire.
6. Plugging the battery charger into an outlet that is not 100 to 240 V can cause a fire or electric

shock. Do not plug the battery charger into an outlet other than 100 to 240 V.

7. Do not use a damaged or modified battery pack or battery charger, which may exhibit unpredictable behavior that results in fire, explosion, or risk of injury.
8. If the supply cord to the battery charger is damaged, contact an Authorized Service Dealer to replace it.
9. Charge the battery pack with only the battery charger specified by Toro. A charger suitable for 1 type of battery pack may create a risk of fire when used with another battery pack.
10. Charge the battery pack in a well-ventilated area only.
11. Follow all charging instructions and do not charge the battery pack outside of the temperature range specified in the instructions. Otherwise, you may damage the battery pack and increase the risk of fire.
12. Dress properly—Wear appropriate clothing, including eye protection; long pants; substantial, slip-resistant footwear; and hearing protection. Tie back long hair and do not wear loose clothing or jewelry that can get caught in moving parts.

### III. Operation

1. Contact with the moving rotor will cause serious injury. Keep your hands and feet away from all moving parts of the machine. Keep clear of any discharge opening.
2. Stay behind the handles and away from the discharge opening while operating the machine.
3. Using this machine for purposes other than its intended use could prove dangerous to you and bystanders.
4. Prevent unintentional starting—Ensure that the electric-start key is removed from the key switch before connecting the battery pack and handling the machine.
5. Use your full attention while operating the machine. Do not engage in any activity that causes distractions; otherwise, injury or property damage may occur.
6. Disengage all clutches and shift into neutral before starting the machine.
7. Stop the machine, remove the electric-start key, remove the battery pack from the machine, and wait for all movement to stop before adjusting, servicing, cleaning, or storing the machine.
8. Remove the battery pack and electric-start key from the machine whenever you leave it unattended or before changing accessories.

9. Do not force the machine—Allow the machine to do the job better and safer at the rate for which it was designed.
10. Stay alert—Watch what you are doing and use common sense when operating the machine. Do not use the machine while ill, tired, or under the influence of alcohol or drugs.
11. Operate the machine only in good visibility and appropriate weather conditions.
12. Use extreme caution when reversing or pulling the machine toward you.
13. Keep proper footing and balance at all times, especially on slopes. Use extreme caution when changing directions on slopes. Do not operate the machine on exceedingly steep slopes. Walk, never run with the machine.
14. When not actively clearing snow, disengage power to the auger.
15. Do not direct the discharge material toward anyone. Avoid discharging material against a wall or obstruction; material may ricochet toward you. Shut off the machine when crossing gravel surfaces.
16. Exercise extreme caution when operating the machine on or crossing gravel drives, walks, or roads. Stay alert for hidden hazards or traffic.
17. If the machine strikes an object or starts to vibrate, immediately shut off the machine, remove the key, remove the battery pack, and wait for all movement to stop before examining the machine for damage. Make all necessary repairs before resuming operation.
18. Shut off the machine whenever you leave the operating position for any reason.
19. Shut off the machine and remove the key before unclogging the machine and always use a stick or a cleanout tool to remove the clog.
20. Shut off the machine and remove the electric-start key before loading the machine for hauling.
21. Never operate the machine at high transport speeds on slippery surfaces.
22. Under abusive conditions, the battery pack may eject liquid; avoid contact. If you accidentally come into contact with the liquid, flush with water. If the liquid contacts your eyes, seek medical help. Liquid ejected from the battery pack may cause irritation or burns.
23. Do not expose a battery pack or tool to fire or excessive temperature. Exposure to fire or temperature above 130°C (265°F) may cause explosion.
24. **CAUTION**—A mistreated battery pack may present a risk of fire, explosion, or chemical burn.
  - Do not disassemble the battery pack.
  - Replace the battery pack with a genuine Toro battery pack only; using another type of battery pack may cause a fire or risk of injury.
  - Keep battery packs out of the reach of children and in the original packaging until you are ready to use them.

#### **IV. Maintenance and Storage**

1. Shut off the machine, remove the electric-start key, remove the battery pack(s) from the machine, and wait for all movement to stop before adjusting, servicing, cleaning, or storing the machine.
2. Do not attempt to repair the machine except as indicated in the instructions. Have an Authorized Service Dealer perform service on the machine using identical replacement parts.
3. Wear gloves and eye protection when servicing the machine.
4. When servicing the rotor, be aware that the rotor can still move even though the power source is off.
5. For best performance, use only genuine Toro replacement parts and accessories. Other replacement parts and accessories could be dangerous, and such use could void the product warranty.
6. Maintain the machine—Keep handles dry, clean, and free from oil and grease. Keep guards in place and in working order. Use identical replacement parts only.
7. Check all fasteners at frequent intervals for proper tightness to ensure that the machine is in safe working condition.
8. Check the machine for damaged parts. Check for misaligned and binding moving parts, broken parts, mounting, and any other condition that may affect its operation. Unless indicated in the instructions, have an Authorized Service Dealer repair or replace a damaged guard or part.
9. When the battery pack is not in use, keep it away from metal objects such as paper clips, coins, keys, nails, and screws that can make a connection from 1 terminal to another. Shorting the battery terminals may cause burns or a fire.
10. When you are not using the machine, store it indoors in a dry, secure place out of the reach of children.

11. When storing the machine for more than 30 days, refer to [Storage \(page 27\)](#) for important information.
12. CAUTION—A mistreated battery pack may present a risk of fire or chemical burn. Do not disassemble the battery pack. Do not heat the battery pack above 68°C (154°F) or incinerate it. Replace the battery pack with a genuine Toro battery pack only; using another type of battery pack may cause a fire or explosion. Keep battery packs out of the reach of children and in the original packaging until you are ready to use them.
13. Do not dispose of the battery in a fire. The cell may explode. Check with local codes for possible special disposal instructions.

## **SAVE THESE INSTRUCTIONS**

# Safety and Instructional Decals



Safety decals and instructions are easily visible to the operator and are located near any area of potential danger. Replace any decal that is damaged or missing.



**121-6817**

1. Cutting/dismemberment hazard of hand or foot, impeller and auger—keep bystanders away.

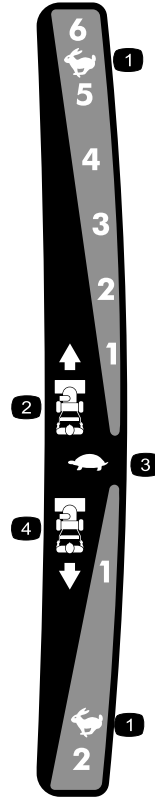

**121-6823**

1. Fast
2. Forward speeds
3. Slow
4. Reverse speeds

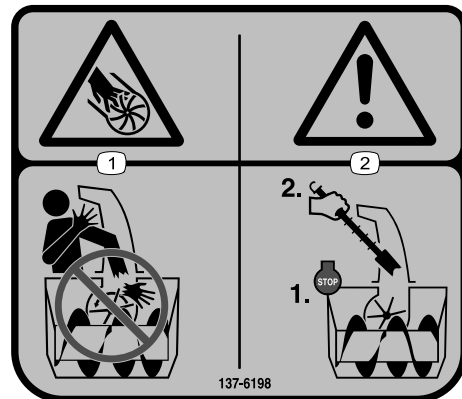

**137-6198**

1. Cutting/dismemberment hazard of the fingers or hand, impeller—do not place your hand in the chute.
2. Warning—shut off the motor before using the tool to clear the chute.



decal121-1240

### 121-1240

1. Traction drive—squeeze the lever to engage; release the lever to disengage.
2. Warning—read the *Operator's Manual*.
3. Cutting/dismemberment hazard of hand, impeller—do not place your hand in the chute; shut off the motor before leaving the operating position; use the tool to clear the chute.
4. Cutting/dismemberment hazard of hand, impeller—stay away from moving parts; keep all guards and shields in place; remove the key and read the *Operator's Manual* before performing maintenance.
5. Thrown object hazard—keep bystanders away.
6. Auger/impeller drive—squeeze the lever to engage; release the lever to disengage.



decal144-6028

### 144-6028

1. Do not dispose improperly
2. Read the *Operator's Manual*.
3. For indoor use
4. Double insulated



decal137-9496

### 137-9496

1. The battery pack is charging.
2. The battery pack is fully charged.
3. The battery pack is over or under the appropriate temperature range.
4. Battery pack charging fault



decal140-8492

**140-8492**

1. Keep away from open fire or flames.
2. Do not expose to rain.
3. Read the *Operator's Manual*.
4. Recycle the battery properly.
5. Contains lithium ions; do not dispose improperly.

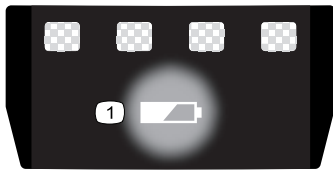

decal137-9461

**137-9461**

1. Battery charge status



# Setup

**Important:** The battery pack is not fully charged when you purchase it. Before using the machine for the first time, refer to [Charging the Battery Pack \(page 18\)](#).

**1**

## Mounting the Battery Charger (Optional)

Parts needed for this procedure:

2	Mounting hardware (not included)
---	----------------------------------

### Procedure

If desired, mount the battery charger securely on a wall using the wall-mount key holes on the back of the charger.

Mount it indoors (such as a garage or other dry place), near a power outlet, and out of the reach of children.

Refer to [Figure 3](#) for assistance in mounting the charger.

Slide the charger over the appropriately positioned hardware to secure the charger in place (hardware not included).

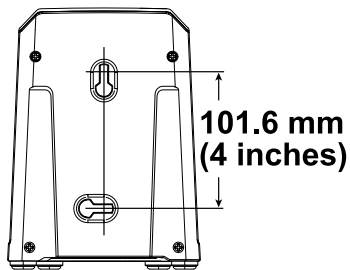

Figure 3

g290534

# 2

## Installing the Upper Handle

No Parts Required

### Procedure

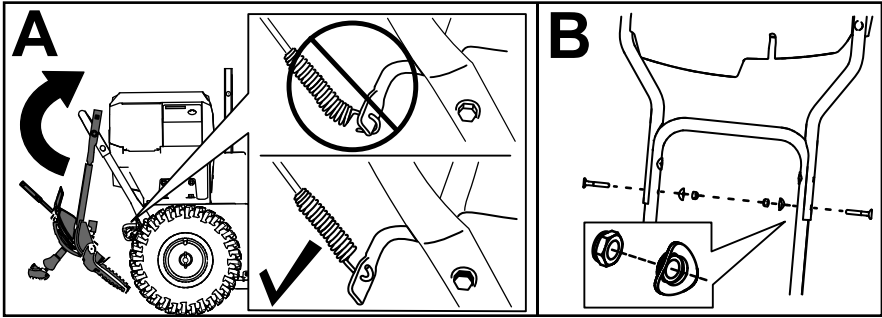
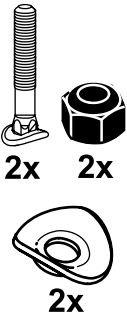

g344090

# 3

## Installing the Chute

No Parts Required

### Procedure

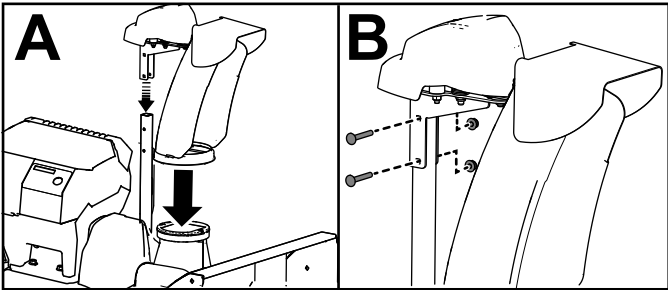
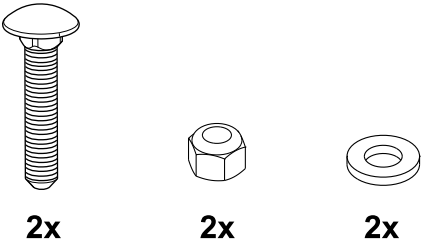

g344087

# 4

## Installing the Traction-Control Linkage

No Parts Required

### Procedure

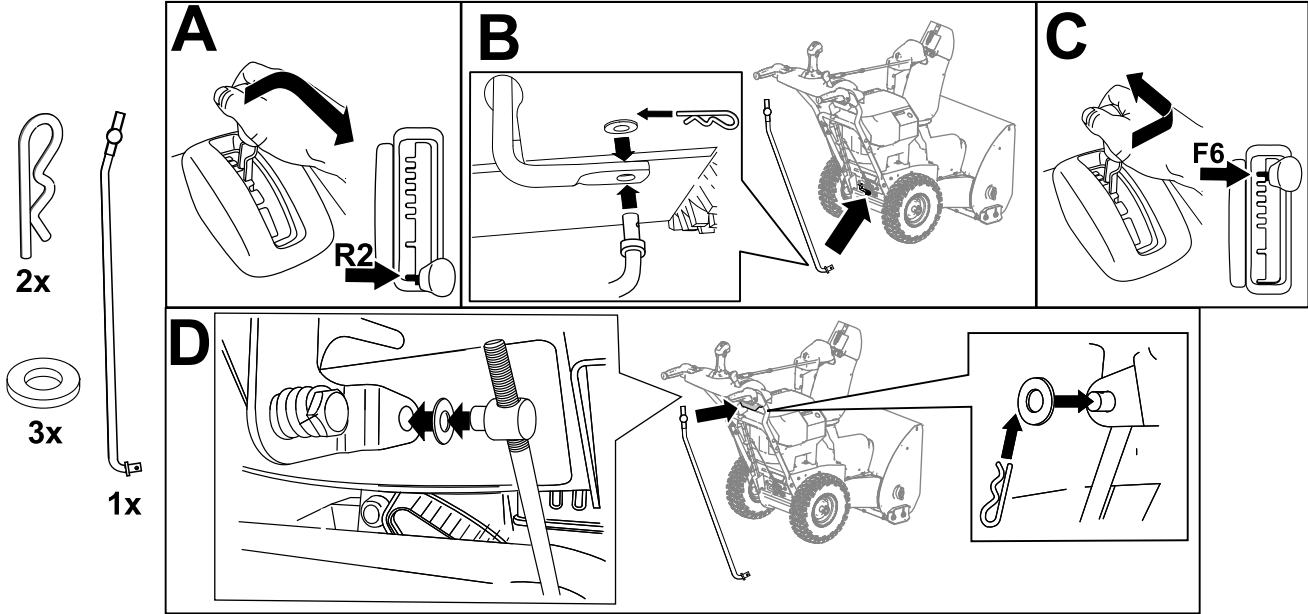

g344089

# 5

## Installing the Chute-Control Rod

No Parts Required

### Procedure

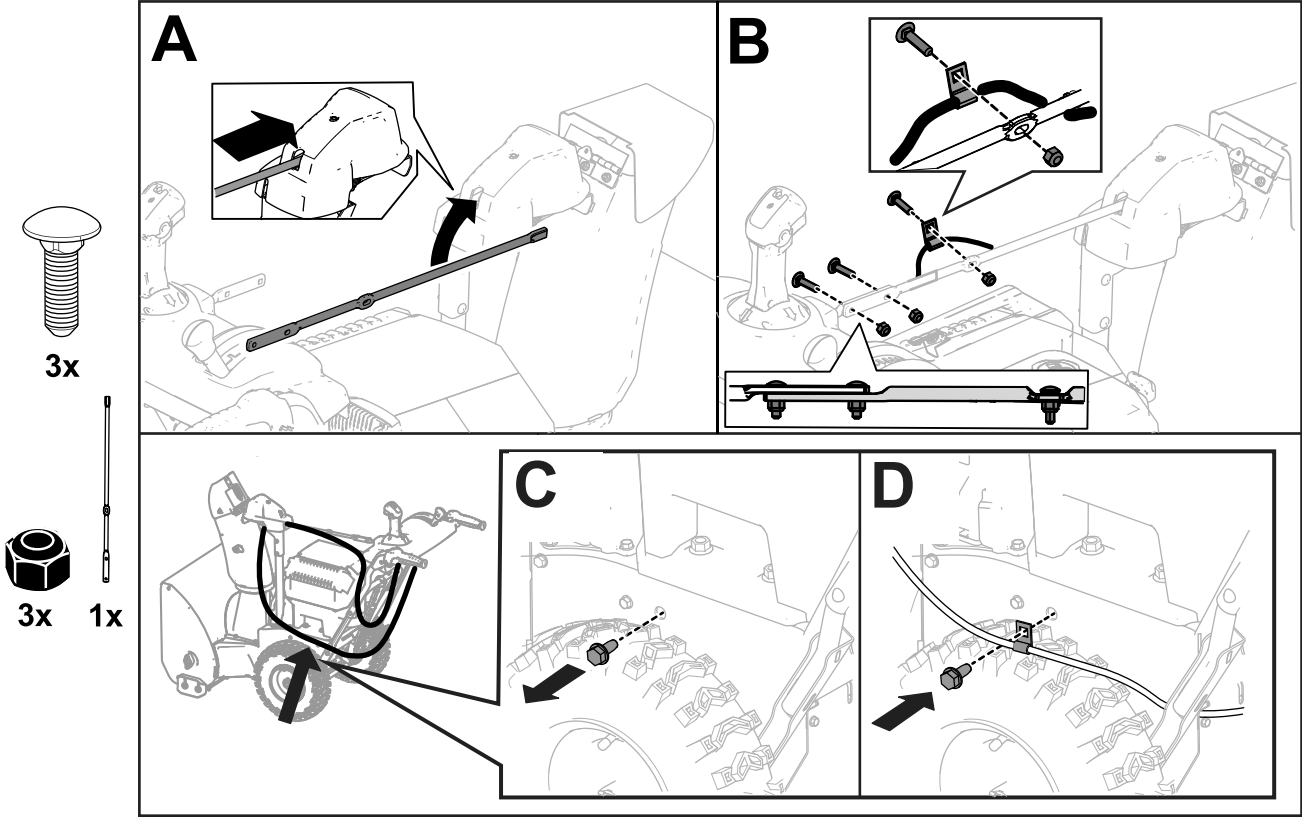

g344086

# 6

## Installing the Snow-Cleanout Tool

No Parts Required

### Procedure

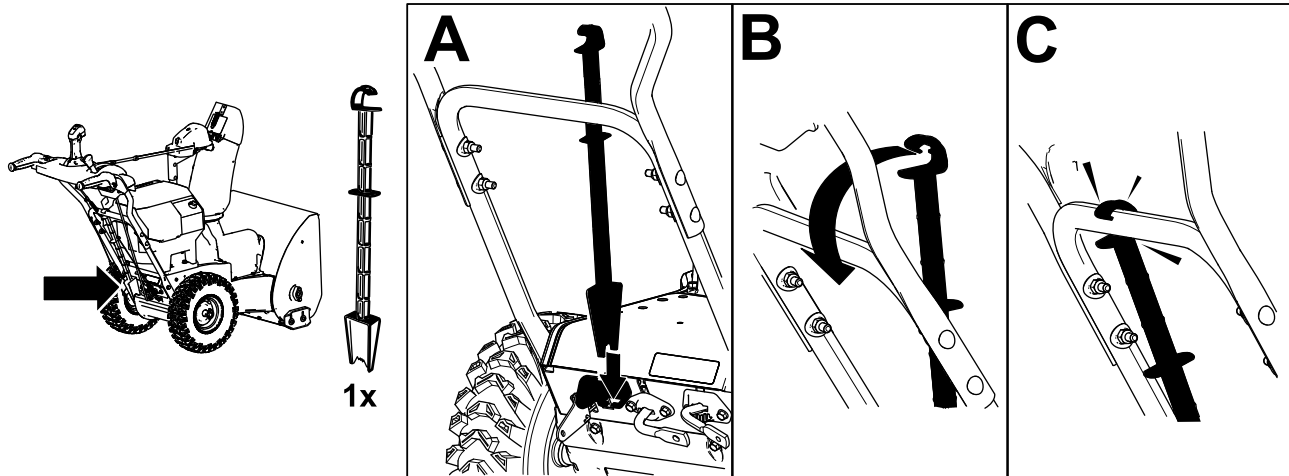

g344088

# 7

## Checking the Tire Pressure

No Parts Required

### Procedure

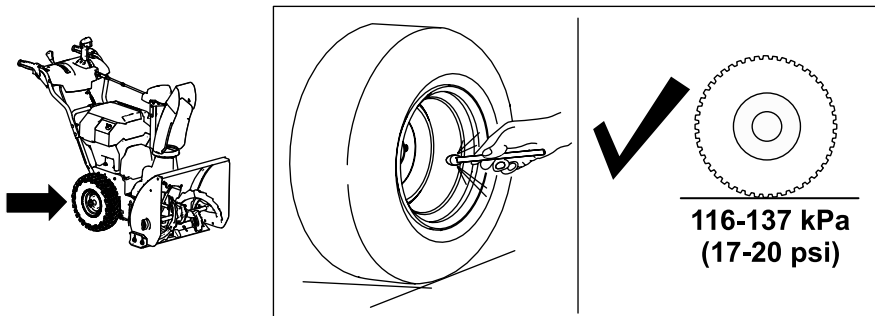

g344084

# 8

## Checking the Skids and Scraper

No Parts Required

### Procedure

Refer to [Checking and Adjusting the Skids and Scraper \(page 23\)](#).

# 9

## Checking the Operation of the Traction Drive

No Parts Required

### Procedure

#### ⚠ CAUTION

If the traction drive is not properly adjusted, the machine may move in the direction opposite of what you intended, causing injury and/or property damage.

Carefully check the traction drive and adjust it properly, if necessary.

1. Start the machine; refer to [Starting the Machine \(page 17\)](#).
2. Move the speed selector to Position R1; refer to [Operating the Speed Selector \(page 19\)](#).
3. Squeeze the left (traction) lever to the handgrip ([Figure 10](#)).

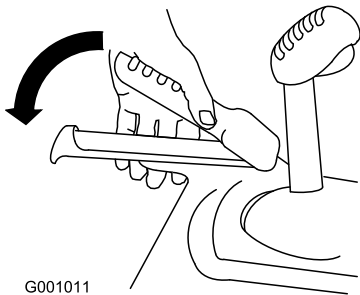

G001011

g001011

Figure 10

The machine should move rearward. If the machine does not move or moves forward, complete the following:

- A. Release the traction lever and shut off the machine; refer to [Shutting Off the Machine \(page 22\)](#).
  - B. Disconnect the trunnion from the speed-selector lever.
  - C. Turn the trunnion downward (clockwise) on the speed-control rod.
  - D. Connect the trunnion to the speed-selector lever.
4. Release the traction lever.
  5. Move the speed selector to Position 1; refer to [Operating the Speed Selector \(page 19\)](#).
  6. Squeeze the left (traction) lever to the handgrip ([Figure 10](#)).

The machine should move forward. If the machine does not move or moves rearward, complete the following:

- A. Release the traction lever and shut off the machine.
  - B. Disconnect the trunnion from the speed-selector lever.
  - C. Turn the trunnion upward (counterclockwise) on the speed-control rod.
  - D. Connect the trunnion to the speed-selector lever.
7. If you made any adjustments, repeat this procedure until no adjustments are required.

**Important:** If the machine moves when the traction lever is in the released position, check the traction cable; refer to [Checking and Adjusting the Traction Cable \(page 24\)](#) or take the machine to an Authorized Service Dealer for service.

# Product Overview

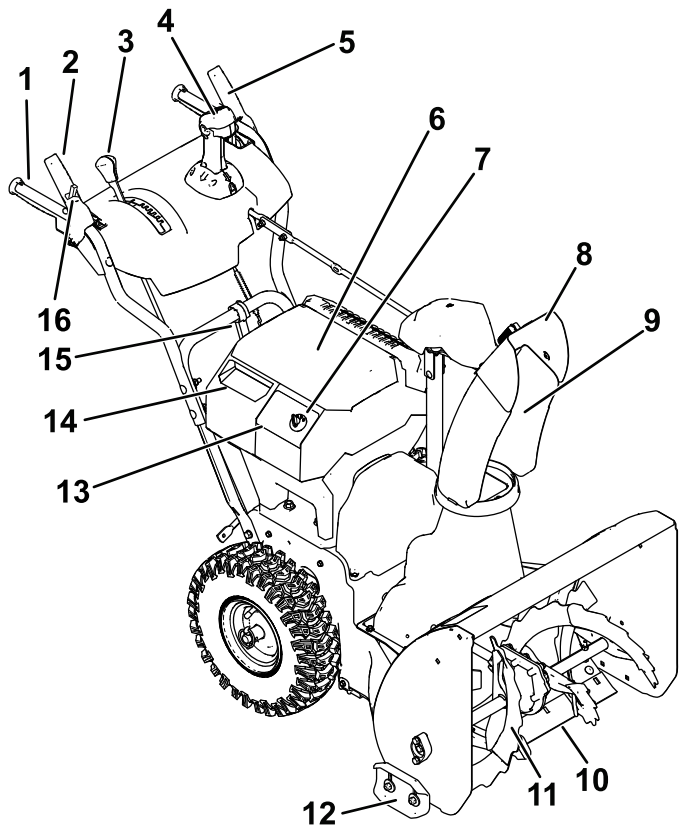

**Figure 11**

g411293

- |   |                                       |
|---|---------------------------------------|
| 1. Handgrip (2)                         | 9. Discharge chute                    |
| 2. Auger/impeller lever                 | 10. Scraper                           |
| 3. Speed-selector lever                 | 11. Auger                             |
| 4. Quick Stick® discharge-chute control | 12. Skid (2)                          |
| 5. Traction lever                       | 13. Control panel                     |
| 6. Main battery-compartment lid         | 14. Secondary battery-compartment lid |
| 7. Electric-start key                   | 15. Snow-cleanout tool                |
| 8. Chute deflector                      | 16. Lock switch                       |

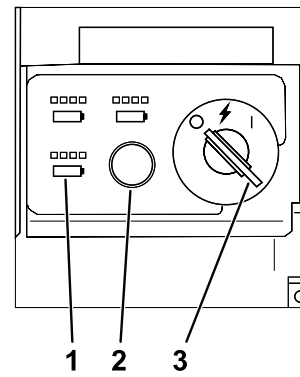

**Figure 12**

g347780

- |                          |                               |
|--------------------------|-------------------------------|
| 1. Battery charge lights | 3. Key switch in OFF position |
| 2. ECO button            |                               |

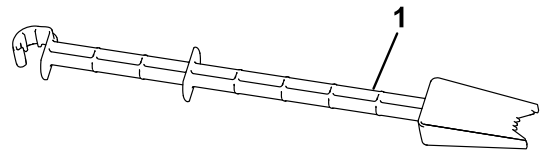

**Figure 13**

g344092

- |  |
|--|
| 1. Snow-cleanout tool (attached to the handle) |
|--|

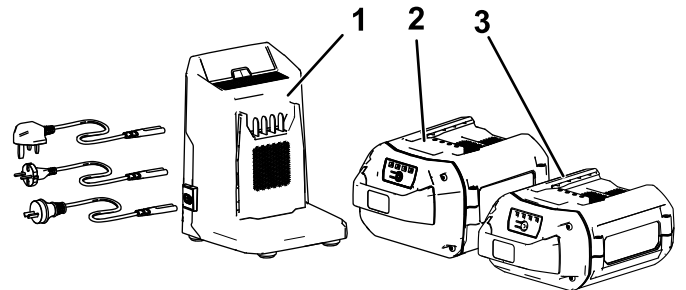

**Figure 14**

g342171

- |  |  |
|--|--|
| 1. Battery charger Model 81805 (included with Model 31875) | 3. Battery pack Model 81825 (not included) |
| 2. Battery pack Model 81875 (included with Model 31875)    |  |

# Specifications

Model	Weight	Length	Width	Height
31875	64 kg (141 lb)	142 cm (56 inches)	71 cm (28 inches)	117 cm (46 inches)

## Battery Pack

Model	81875
Battery pack capacity	7.5 Ah
	405 Wh
Battery manufacturer rating = 60V maximum and 54V nominal. Actual voltage varies with load.	

## Battery Charger

Model	81805
Type	60V MAX Lithium-Ion Battery Rapid Charger
Input	100 to 240V AC 50/60Hz Max 5.0A
Output	60V MAX DC 5.5A

## Appropriate Temperature Ranges

Charge/store the battery pack at	5°C (41°F) to 40°C (104°F)*
Use the battery pack at	-30°C (-22°F) to 49°C (120°F)*
Use the machine at	-30°C (-22°F) to 49°C (120°F)*

\*Charging time will increase if you do not charge the battery within this range.

Store the machine, battery pack, and battery charger in an enclosed clean, dry area.

## Attachments/Accessories

A selection of Toro approved attachments and accessories is available for use with the machine to enhance and expand its capabilities. Contact your Authorized Service Dealer or authorized Toro distributor or go to [www.Toro.com](http://www.Toro.com) for a list of all approved attachments and accessories.

To ensure optimum performance and continued safety certification of the machine, use only genuine Toro replacement parts and accessories. Replacement parts and accessories made by other manufacturers could be dangerous.

# Operation

**Note:** Determine the left and right sides of the machine from the normal operating position.

## Before Operation

### Installing the Battery Pack

1. Ensure that the vents on the battery packs are clear of any dust and debris.
2. Lift up the battery-compartment lid.
3. Line up the cavity in the battery pack with the tongue on the machine and slide the battery pack into the compartment until it lock into place (Figure 9).
4. Close the battery-compartment lid.
5. Repeat for the other 2 battery cavities (if needed).

**Note:** The combined amp hours of all the installed batteries must add up to 6.0 or greater, otherwise the machine can not start.

**Note:** If the battery-compartment lid does not close completely, the battery is not fully installed.

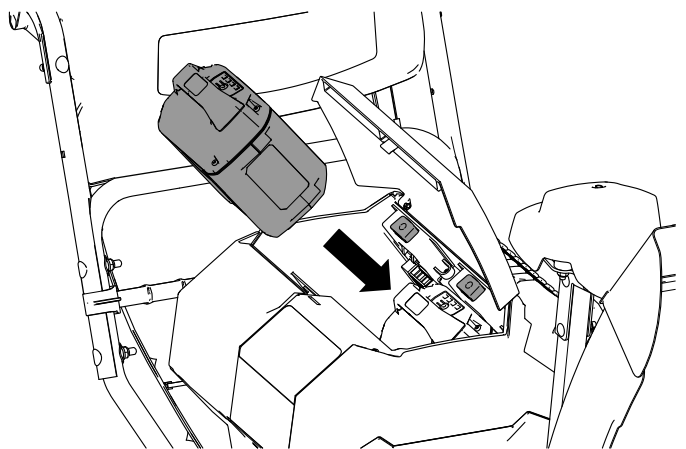

Figure 15

g348180



# Checking the State of Charge

You can view the exact state of charge of each installed battery; turn the key to the ACCESSORY position (Figure 16). The position of each set of lights corresponds to the related battery cavity. If the battery state of charge is too low and needs to be charged, or if there is no battery in the corresponding cavity, the battery presence light does not turn on.

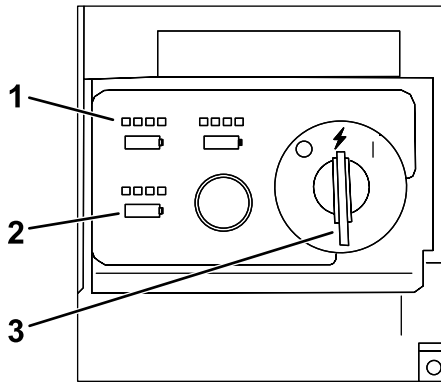

Figure 16

g348182

1. State-of-charge lights
2. Battery presence lights
3. Key switch in the ACCESSORY position

## During Operation

### Starting the Machine

**Note:** Use the battery pack only in temperatures that are within the appropriate range; refer to [Specifications \(page 16\)](#).

1. Ensure that the battery pack(s) are installed in the machine; refer to [Installing the Battery Pack \(page 16\)](#).
2. Insert the electric-start key into the control panel.
3. Turn the key to the ACCESSORY position.
4. Turn the key to the ON position to turn on the machine (Figure 17).

**Note:** If the key is turned from OFF position to the ON too quickly, the machine may not start; ensure that the key stops briefly in the middle ACCESSORY position.

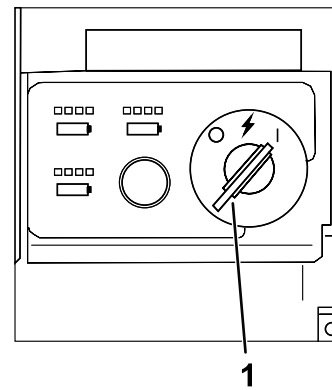

Figure 17

g347864

1. Key switch in ON position

**Note:** If the machine is turned on and left idling or operating without the auger engaged for an extended period, the motor shutoff timeout will engage, shutting off the machine. When the machine shuts off this way it beeps to indicate that the timeout was engaged.

### Activating ECO Mode

Using ECO mode may extend battery life by reducing rotor speed; use ECO mode whenever you are moving light snow, or moving snow a short distance. Activate ECO mode using the ECO button as shown in Figure 18.

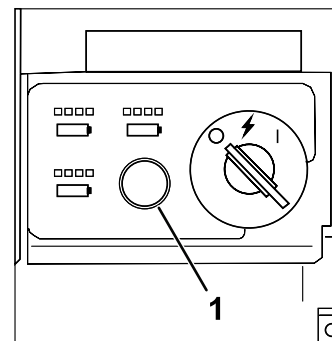

Figure 18

g347866

1. ECO mode button

# Charging the Battery Pack

**Important:** The battery pack is not fully charged when you purchase it. Before using the tool for the first time, place the battery pack in the charger and charge it until the LED display indicates the battery pack is fully charged. Read all safety precautions.

**Important:** Charge the battery pack only in temperatures that are within the appropriate range; refer to [Specifications \(page 16\)](#).

**Note:** At any time, press the battery-charge-indicator button on the battery pack to display the current charge (LED indicators).

1. Ensure that the vents on the battery and charger are clear of any dust and debris.

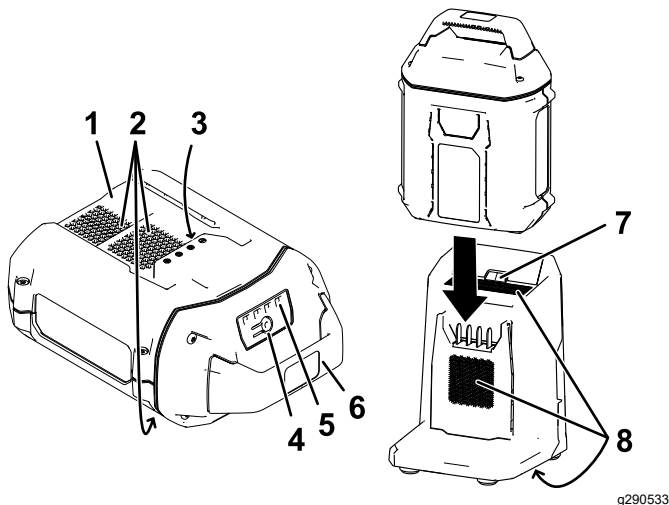

**Figure 19**

- |                                    |                                    |
|------------------------------------|------------------------------------|
| 1. Battery pack cavity             | 5. LED indicators (current charge) |
| 2. Battery pack venting areas      | 6. Handle                          |
| 3. Battery pack terminals          | 7. Charger LED indicator light     |
| 4. Battery-charge-indicator button | 8. Charger venting areas           |
2. Line up the cavity in the battery pack ([Figure 19](#)) with the tongue on the charger.
  3. Slide the battery pack into the charger until it is fully seated ([Figure 19](#)).

4. To remove the battery pack, slide the battery backward out of the charger.
5. Refer to the following table to interpret the LED indicator light on the battery charger.

Indicator light	Indicates
Off	No battery pack inserted
Green blinking	Battery pack is charging
Green	Battery pack is charged
Red	Battery pack and/or battery charger is over or under the appropriate temperature range
Red blinking	Battery pack charging fault*

\*Refer to [Troubleshooting \(page 28\)](#) for more information.

**Important:** The battery can be left on the charger for short periods between uses.

If the battery will not be used for longer periods, remove the battery from the charger; refer to [Storage \(page 27\)](#).

# Operating the Traction Drive

## ⚠ CAUTION

If the traction drive is not properly adjusted, the machine may move in the direction opposite of what you intended, causing injury and/or property damage.

Carefully check the traction drive and adjust it properly, if necessary; refer to [Checking and Adjusting the Traction Cable \(page 24\)](#) for more information.

**Important:** If the machine moves when the traction lever is in the released position, check the traction cable; refer to [Checking and Adjusting the Traction Cable \(page 24\)](#) or take the machine to an Authorized Service Dealer for service.

1. To engage the traction drive, squeeze the left (traction) lever to the handgrip ([Figure 20](#)).

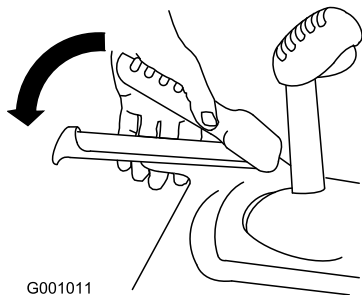

G001011

Figure 20

g001011

2. To stop the traction drive, release the traction lever.

# Operating the Speed Selector

The speed selector has 6 forward and 2 reverse gears. To change speeds, release the traction lever and shift the speed-selector lever to the desired position ([Figure 21](#)). The lever locks in a notch at each speed selection.

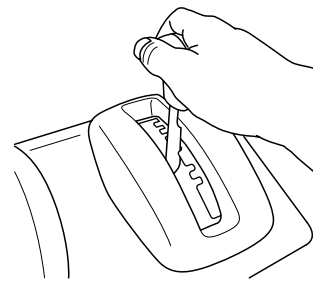

Figure 21

g322971

# Operating the Auger/Impeller Drive

1. To engage the auger/impeller drive, move back the lock switch on the lever, then squeeze the right (auger/impeller) lever to the handgrip ([Figure 22](#)).

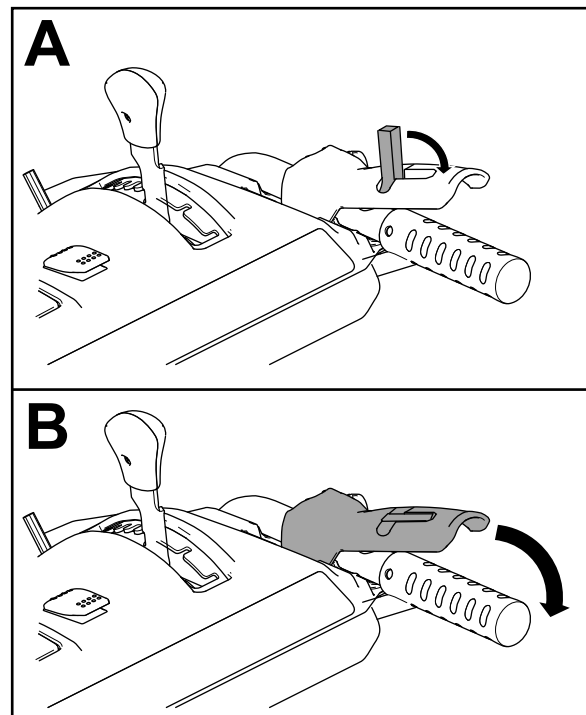

Figure 22

g360687

2. To stop the auger and impeller, release the right lever.

**Important:** When you engage both the auger/impeller lever and the traction lever, the traction lever locks the auger/impeller lever down, freeing your right hand. To release both levers, simply release the left (traction) lever.

3. If the auger and impeller continue to rotate when you release the auger/impeller lever, do not

operate the machine. Check the auger/impeller cable; refer to [Checking and Adjusting the Auger/Impeller Cable \(page 25\)](#) and adjust it if necessary. Otherwise, take the machine to an Authorized Service Dealer for service.

**⚠ WARNING**

If the auger and impeller continue to rotate when you release the auger/impeller lever, you could seriously injure yourself or others.

Do not operate the machine. Take it to an Authorized Service Dealer for service.

## Operating the Quick Stick®

Hold the blue trigger cap down to use the Quick Stick to move the discharge chute and the chute deflector. Release the trigger cap to lock the discharge chute and chute deflector into position ([Figure 23](#)).

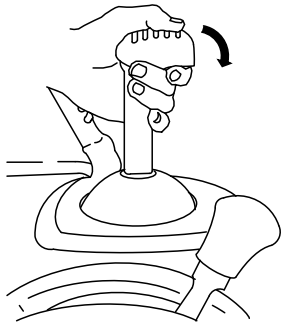

G001014

**Figure 23**

g001014

## Moving the Discharge Chute

Hold the blue trigger cap down and move the Quick Stick to the left to move the discharge chute to the left; move the Quick Stick to the right to move the discharge chute to the right ([Figure 24](#)).

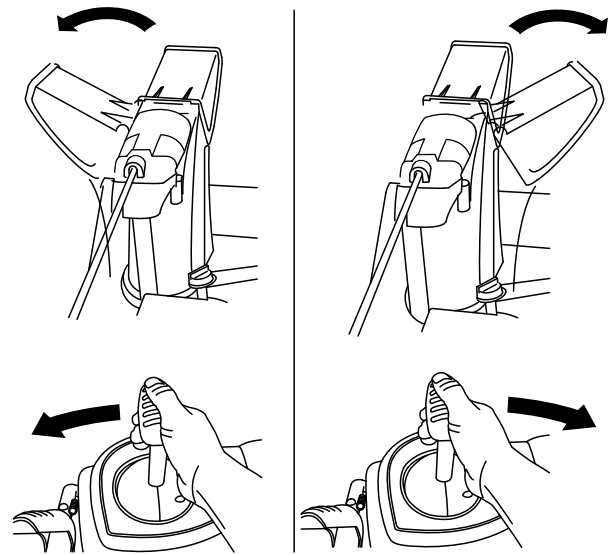

g018894

g018894

**Figure 24**

- If the chute does not turn as far to the left as it does to the right, ensure that the cable is routed to the inside of the handles. Refer to [2 Installing the Upper Handle \(page 9\)](#).
- If the chute does not move, or does not lock into place when you release the trigger cap, you must adjust the discharge-chute latch cable.

## Moving the Chute Deflector

Hold the blue trigger cap down and move the Quick Stick forward to lower the chute deflector; move it rearward to raise the chute deflector ([Figure 25](#)).

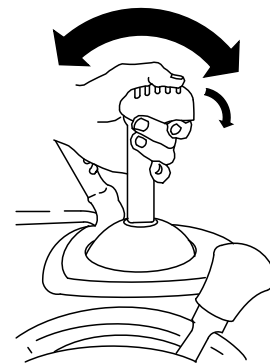

G001016

g001016

**Figure 25**

# Clearing a Clogged Discharge Chute

## ⚠ WARNING

If the auger/impeller is running but there is no snow coming out of the discharge chute, the discharge chute may be clogged.

Never use your hands to clear a clogged discharge chute. This could result in personal injury.

- To unclog the discharge chute, stay in the operating position and release the left (traction) lever. While running the auger/impeller, push down on the handles to raise the front of the machine a few centimeters (inches) off the pavement. Then lift the handles quickly to bump the front of the machine on the pavement. Repeat if necessary until a stream of snow comes out the discharge chute.
- If you cannot unclog the discharge chute by bumping the front of the machine, **shut off the machine, wait for all moving parts to stop, and use the snow-cleanout tool (Figure 13).**

**Important:** Unclogging the discharge chute by bumping the front of the machine on the pavement may cause the skids to move. Adjust the skids and tighten the skid bolts securely; refer to [Checking and Adjusting the Skids and Scraper \(page 23\)](#).

# Operating Tips

## ⚠ DANGER

When the machine is in operation, the impeller and auger rotate and can injure or amputate hands or feet.

- Before adjusting, cleaning, inspecting, troubleshooting, or repairing the machine, shut off the machine and wait for all moving parts to stop. Remove the key and the battery from the machine to prevent someone from accidentally starting the machine.
- Remove any obstructions from the discharge chute; refer to [Clearing a Clogged Discharge Chute \(page 21\)](#). Use the snow-cleanout tool ([Figure 13](#)), not your hands, to remove an obstruction from the discharge chute.
- Stay behind the handles and away from the discharge opening while operating the machine.
- Keep your face, hands, feet, and any other part of your body or clothing away from concealed, moving, or rotating parts.

## ⚠ WARNING

The impeller can throw stones, toys, and other foreign objects and cause serious personal injury to you or bystanders.

- Keep the area to be cleared free of all objects that the auger could pick up and throw.
- Keep all children and pets away from the area of operation.

For best results, consider the following:

- If the machine slows down under a load or the wheels slip, shift the machine into a lower gear; refer to [Operating the Speed Selector \(page 19\)](#).
- If the front of the machine rides up, shift the machine into a lower gear. If the front continues to ride up, lift up on the handles.
- Remove the snow as soon as possible after it falls.
- Push the machine forward, but allow it to work at its own pace.
- Overlap each swath to ensure complete snow removal.
- Discharge the snow downwind whenever possible.

# After Operation

## Shutting Off the Machine

1. Release the traction and auger/impeller levers.
2. Turn the key to the OFF position and remove it from the control panel (Figure 12).
3. Remove the battery pack(s); refer to [Removing the Battery Pack from the Machine](#) (page 22).

**Note:** Whenever you are not using the machine, remove the battery pack(s) and the key from the machine.

**Note:** If the machine is turned on and left idling or operating without the auger engaged for an extended period, the motor shutoff timeout will engage, shutting off the machine. When the machine shuts off this way it beeps to indicate that the timeout was engaged.

To restart the machine refer to [Starting the Machine](#) (page 17).

## Removing the Battery Pack from the Machine

1. Lift up the battery-compartment lid.
2. Press the battery pack-latch to release the battery pack and remove the battery pack (Figure 26).

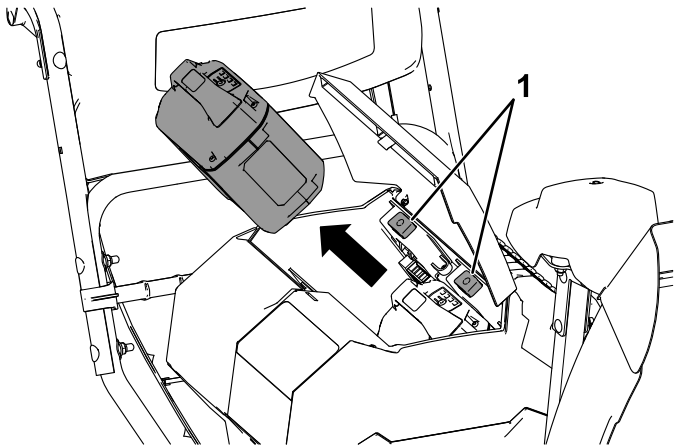

Figure 26

3. Close the battery-compartment lid.

## Preventing Freeze-up after Use

- In snowy and cold conditions, some controls and moving parts may freeze. **Do not use excessive force when trying to operate frozen controls.** If you have difficulty operating any control or part, start the machine and let it run for a few minutes.
- After using the machine, let the machine run for a few minutes to prevent moving parts from freezing. Engage the auger/impeller to clear any remaining snow from inside the housing. Rotate the Quick Stick to prevent it from freezing. Shut off the machine, wait for all moving parts to stop, remove the key and the battery, and remove all ice and snow from the machine.
- Clean off any snow and ice from the base of the chute.
- Rotate the discharge chute left and right to free it from any ice buildup.

# Maintenance

## Recommended Maintenance Schedule(s)

Maintenance Service Interval	Maintenance Procedure
After the first 2 hours	<ul style="list-style-type: none"><li>• Inspect the traction cable and adjust it if necessary.</li><li>• Inspect the auger/impeller cable and adjust it if necessary.</li></ul>
Yearly	<ul style="list-style-type: none"><li>• Check the skids and the scraper and adjust them if necessary.</li><li>• Inspect the traction cable and adjust or replace it if necessary.</li><li>• Inspect the auger/impeller cable and adjust or replace it if necessary.</li><li>• Check the auger-gearbox oil and add oil if necessary.</li><li>• Lubricate the hex shaft.</li></ul>
Yearly or before storage	<ul style="list-style-type: none"><li>• Check the air pressure in the tires and inflate them to 116 to 137 kPa (17 to 20 psi).</li><li>• Have an Authorized Service Dealer inspect and replace the traction-drive belt and/or the auger/impeller drive belt, if necessary.</li></ul>

## Preparing for Maintenance

1. Move the machine to a level surface.
2. Stop the machine, remove the electric-start key, wait for all movement to stop, and remove the battery pack from the machine before adjusting, servicing, cleaning, or storing the machine.

## Checking and Adjusting the Skids and Scraper

**Service Interval:** Yearly—Check the skids and the scraper and adjust them if necessary.

Check the skids and the scraper to ensure that the auger does not contact the paved or gravel surface. Adjust the skids and the scraper as needed to compensate for wear.

1. Check the tire pressure; refer to [7 Checking the Tire Pressure \(page 13\)](#).
2. Loosen the nuts that secure both skids to the auger sides until the skids slide up and down easily.

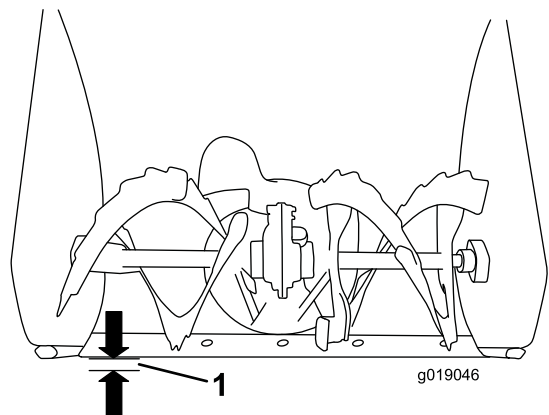

**Figure 27**

1. 3 mm (1/8 inch)

**Important:** The auger blades must be supported above the ground by the skids.

3. Ensure that the scraper is 3 mm (1/8 inch) above and parallel to a level surface.

**Note:** If the pavement is cracked, rough, or uneven, adjust the skids to raise the scraper. For gravel surfaces, adjust the skids further down to prevent the machine from picking up rocks.

4. Move the skids down until they are even with the ground.
5. Firmly tighten the nuts that secure both skids to the auger sides.

**Note:** To quickly adjust the skids if they loosen, support the scraper 3 mm (1/8 inch) off the pavement, then adjust the skids down to the pavement.

**Note:** If the skids become excessively worn, you can turn them over and set the unused side toward the pavement.

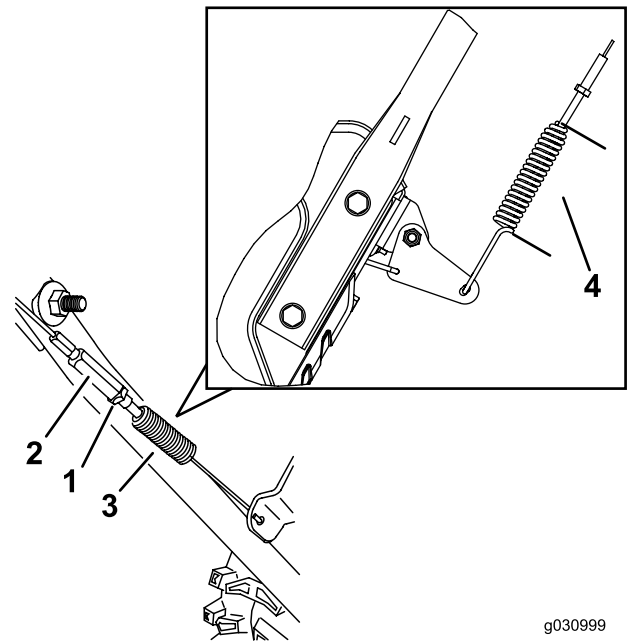

g030999

g030998

**Figure 29**

- |               |                           |
|---------------|---------------------------|
| 1. Jam nut    | 3. Spring                 |
| 2. Turnbuckle | 4. 5.5 cm (2–3/16 inches) |

## Checking and Adjusting the Traction Cable

**Service Interval:** After the first 2 hours—Inspect the traction cable and adjust it if necessary.

Yearly—Inspect the traction cable and adjust or replace it if necessary.

If the machine does not drive in the forward or reverse speeds or it drives when you release the traction lever, adjust the traction cable.

If the left (traction) cable is not properly adjusted, do the following steps:

1. Loosen the jam nut.
2. Engage the traction lever and hold it in place (Figure 28).

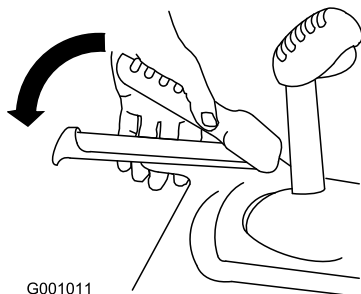

G001011

g001011

**Figure 28**

3. Loosen or tighten the turnbuckle to adjust the spring length to 5.5 cm (2–3/16 inches) as shown in Figure 29.



# Checking and Adjusting the Auger/Impeller Cable

**Service Interval:** After the first 2 hours—Inspect the auger/impeller cable and adjust it if necessary.

Yearly—Inspect the auger/impeller cable and adjust or replace it if necessary.

1. Loosen the jam nut ([Figure 31](#)).
2. Engage the auger/impeller lever and hold it in place ([Figure 30](#)).

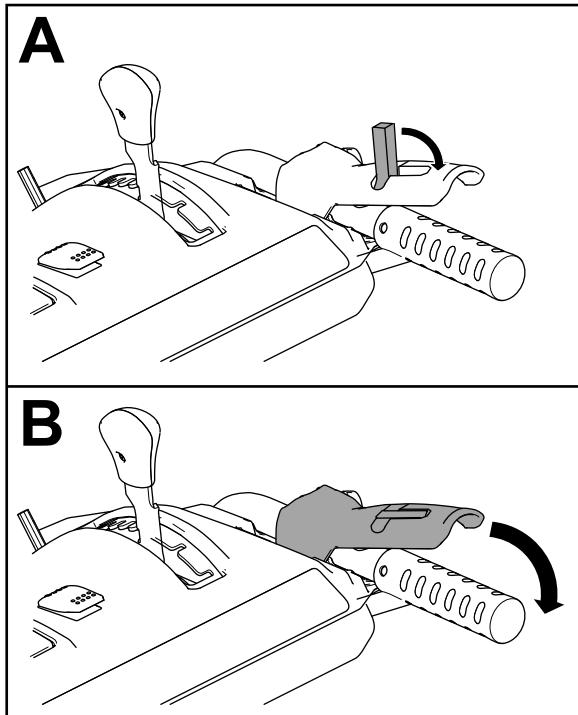

**Figure 30**

g360687

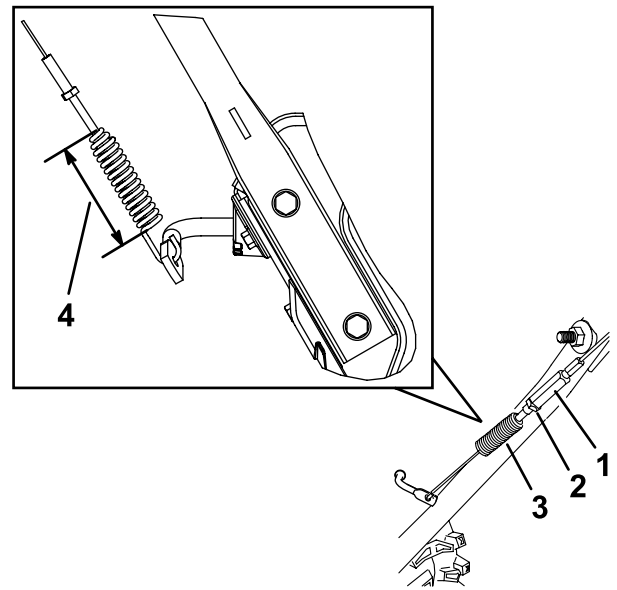

**Figure 31**

g371834

1. Turnbuckle
  2. Jam nut
  3. Spring
  4. 6.6 cm (2-3/5 inches) while the auger/impeller lever is held down.
- 
4. Tighten the jam nut ([Figure 31](#)), ensuring that there is slight tension on the cable.
  5. Turn on the machine and attempt to engage the auger/impeller drive without moving the lock switch back; if the auger rotates, loosen the turnbuckle so that the auger does not engage.
  6. If the auger/impeller cable is properly adjusted but a problem remains, contact an Authorized Service Dealer.

3. Loosen or tighten the turnbuckle to adjust the spring length to 6.6 cm (2-3/5 inches) as shown in [Figure 31](#).

# Checking the Auger-Gearbox-Oil Level

**Service Interval:** Yearly—Check the auger-gearbox oil and add oil if necessary.

1. Move the machine to a level surface.
2. Clean the area around the pipe plug (Figure 32).

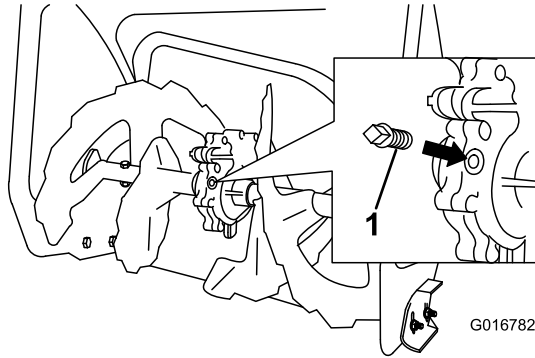

Figure 32

1. Pipe plug

3. Remove the pipe plug from the gearbox.
4. Check the oil level in the gearbox. The oil should be 9.5 mm (3/8 inch) below the filler opening.
5. If the oil level is low, add GL-5 or GL-6, SAE 80-90 EP gear oil lubricant to the gearbox until the oil level is 9.5 mm (3/8 inch) below the filler opening.

**Note:** Do not use synthetic oil.

6. Install the pipe plug in the gearbox.

# Lubricating the Hex Shaft

**Service Interval:** Yearly—Lubricate the hex shaft.

Lightly lubricate the hex shaft yearly with automotive engine oil (Figure 33).

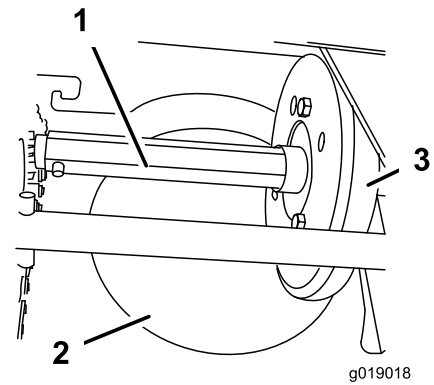

Figure 33

1. Hex shaft
2. Steel friction pulley
3. Rubber wheel

**Important:** Do not get oil on the rubber wheel or the steel friction pulley because the traction drive will slip (Figure 33).

1. Drain the fuel from the fuel tank.
2. Tip the machine forward onto its auger housing and block it so that it cannot fall.
3. Remove the back cover (Figure 34).

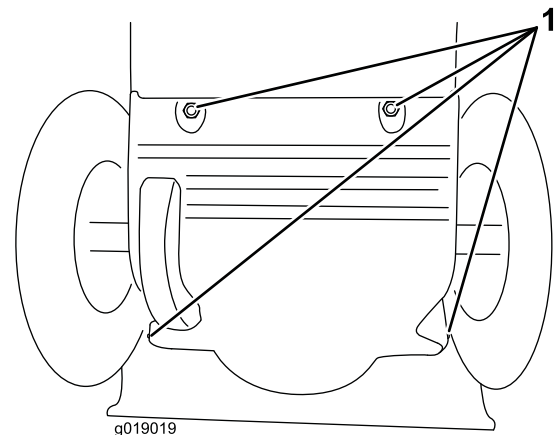

Figure 34

1. Screws
4. Move the speed-selector lever to Position R2.
5. Dip your finger in automotive engine oil and **lightly** lubricate the hex shaft.
6. Move the speed-selector lever to Position 6.
7. Lubricate the other end of the hex shaft.
8. Move the speed-selector lever forward and rearward a few times.
9. Install the back cover and return the machine to the operating position.

## Replacing the Drive Belts

If the auger/impeller drive belt or the traction-drive belt becomes worn, oil-soaked, or otherwise damaged, have an Authorized Service Dealer replace the belt.

## Storage

### Storing the Machine

**Important:** Store the machine, battery pack, and charger only in temperatures that are within the appropriate range; refer to [Specifications \(page 16\)](#).

**Important:** If you are storing the battery pack for the off-season, charge it until 2 or 3 LED indicators turn green on the battery. Do not store a fully charged or fully depleted battery. When you are ready to use the machine again, charge the battery pack until the left indicator light turns green on the charger or all 4 LED indicators turn green on the battery.

- Disconnect the product from the power supply (i.e., remove the plug from the power supply or the battery pack), remove the key, and check for damage after use.
- Clean all foreign material from the product.
- Do not store the tool with the battery pack installed.
- When not in use, store the machine, battery pack, key, and battery charger out of the reach of children.
- Keep the machine, battery pack, key, and battery charger away from corrosive agents, such as garden chemicals and de-icing salts.
- To reduce the risk of serious personal injury, do not store the battery pack outside or in vehicles.
- Touch up chipped surfaces with paint available from an Authorized Service Dealer. Sand affected areas before painting, and use a rust preventative to prevent the metal parts from rusting.
- Tighten all loose screws, bolts, and locknuts. Repair or replace any damaged parts.
- Store the machine, battery pack, key, and battery charger in an enclosed clean, dry area.

### Preparing the Battery Pack for Recycling

**Important:** Upon removal, cover the terminals of the battery pack with heavy-duty adhesive tape. Do not attempt to destroy or disassemble the battery pack or remove any of its components.

Contact your local municipality or your authorized Toro distributor for more information on how to responsibly recycle the battery.

# Troubleshooting

Problem	Possible Cause	Corrective Action
The machine does not run or does not run continuously.	<ol style="list-style-type: none"> <li>1. The motor shutoff timeout was reached because the auger was not engaged for an extended period of time.</li> <li>2. The key was turned from OFF to ON too quickly.</li> <li>3. The battery pack is low on charge.</li> <li>4. The battery pack is not fully seated.</li> <li>5. The battery pack is over or under the appropriate temperature range.</li> <li>6. The battery pack has exceeded high amperage limits.</li> <li>7. There is moisture on the leads of the battery pack.</li> <li>8. The battery pack is damaged.</li> <li>9. There is another electrical problem with the machine.</li> </ol>	<ol style="list-style-type: none"> <li>1. No issue, restart the machine. The machine beeps to indicate that the motor shutoff timeout was reached.</li> <li>2. Turn the key slower, ensure that the key stops briefly in the middle ACCESSORY position.</li> <li>3. Charge the battery pack.</li> <li>4. Ensure that the battery pack is inserted all the way into the housing.</li> <li>5. Move the battery pack to a place where it is dry and the temperature is between 5°C (41°F) and 40°C (104°F).</li> <li>6. Release the trigger, then press the trigger switch.</li> <li>7. Allow the battery pack to dry or wipe it dry.</li> <li>8. Replace the battery pack.</li> <li>9. Contact an Authorized Service Dealer.</li> </ol>
The machine does not reach full power.	<ol style="list-style-type: none"> <li>1. The battery pack charge capacity is too low.</li> <li>2. The air vents are blocked.</li> </ol>	<ol style="list-style-type: none"> <li>1. Remove the battery pack from the machine and fully charge the battery pack.</li> <li>2. Clean the air vents.</li> </ol>
The machine is producing a beeping sound.	<ol style="list-style-type: none"> <li>1. The motor shutoff timeout was reached because the auger was not engaged for an extended period of time.</li> <li>2. The battery pack is low on charge.</li> <li>3. The machine is overloaded.</li> <li>4. There is another electrical problem with the machine.</li> </ol>	<ol style="list-style-type: none"> <li>1. No issue, restart the machine. The machine beeps to indicate that the motor shutoff timeout was reached.</li> <li>2. Charge the battery pack.</li> <li>3. Walk at a slower pace while clearing snow or break up a large pile of snow before clearing it.</li> <li>4. Attempt the other troubleshooting actions, if the alarm still sounds, contact an Authorized Service Dealer.</li> </ol>
The machine runs, but the machine discharges snow poorly or not at all.	<ol style="list-style-type: none"> <li>1. The machine is moving too fast to clear the snow.</li> <li>2. You are trying to remove too much snow per swath.</li> <li>3. You are trying to remove extremely heavy or wet snow.</li> <li>4. The discharge chute is plugged.</li> <li>5. The auger/impeller drive belt is loose or is off the pulley.</li> <li>6. The auger/impeller drive belt is worn or broken.</li> </ol>	<ol style="list-style-type: none"> <li>1. Shift the machine into a lower gear.</li> <li>2. Reduce the amount of snow removed per swath.</li> <li>3. Do not overload the machine with extremely heavy or wet snow.</li> <li>4. Unclog the discharge chute.</li> <li>5. Install and/or adjust the auger/impeller drive belt; refer to <a href="http://www.Toro.com">www.Toro.com</a> for servicing information or take the machine to an Authorized Service Dealer.</li> <li>6. Replace the auger/impeller drive belt; refer to <a href="http://www.Toro.com">www.Toro.com</a> for servicing information or take the machine to an Authorized Service Dealer.</li> </ol>
The discharge chute either does not lock into place or does not move.	<ol style="list-style-type: none"> <li>1. The discharge-chute latch cable is not properly adjusted.</li> </ol>	<ol style="list-style-type: none"> <li>1. Adjust the discharge-chute latch cable.</li> </ol>

Problem	Possible Cause	Corrective Action
The machine does not properly clear the snow off the surface.	<ol style="list-style-type: none"> <li>1. The skids and/or scraper are not properly adjusted.</li> <li>2. The pressure in the tires is not equal.</li> </ol>	<ol style="list-style-type: none"> <li>1. Adjust the skids and/or the scraper.</li> <li>2. Check and adjust the pressure in 1 or both tires.</li> </ol>
The battery pack loses charge quickly.	<ol style="list-style-type: none"> <li>1. The battery pack is over or under the appropriate temperature range.</li> <li>2. The machine is overloaded.</li> </ol>	<ol style="list-style-type: none"> <li>1. Move the battery pack to a place where it is dry and the temperature is between 5°C (41°F) and 40°C (104°F).</li> <li>2. Push the machine with less force.</li> </ol>
The battery charger is not working.	<ol style="list-style-type: none"> <li>1. The battery charger is over or under the appropriate temperature range.</li> <li>2. The outlet that the battery charger is plugged into does not have power.</li> </ol>	<ol style="list-style-type: none"> <li>1. Unplug the battery charger and move it to a place where it is dry and the temperature is between 5°C (41°F) and 40°C (104°F).</li> <li>2. Contact your licensed electrician to repair the outlet.</li> </ol>
The LED indicator light on the battery charger is red.	<ol style="list-style-type: none"> <li>1. The battery charger and/or battery pack is over or under the appropriate temperature range.</li> </ol>	<ol style="list-style-type: none"> <li>1. Unplug the battery charger and move the battery charger and battery pack to a place where it is dry and the temperature is between 5°C (41°F) and 40°C (104°F).</li> </ol>
The LED indicator light on the battery charger is blinking red.	<ol style="list-style-type: none"> <li>1. There is an error in the communication between the battery pack and the charger.</li> <li>2. The battery pack is weak.</li> </ol>	<ol style="list-style-type: none"> <li>1. Remove the battery pack from the battery charger, unplug the battery charger from the outlet, and wait 10 seconds. Plug the battery charger into the outlet again and place the battery pack on the battery charger. If the LED indicator light on the battery charger is still blinking red, repeat this procedure again. If the LED indicator light on the battery charger is still blinking red after 2 attempts, properly dispose of the battery pack at a battery recycling facility.</li> <li>2. Contact your authorized service dealer if the battery is in warranty, or properly dispose of the battery pack at a battery recycling facility.</li> </ol>

**Notes:**

## EEA/UK Privacy Notice

### **Toro's Use of Your Personal Information**

The Toro Company ("Toro") respects your privacy. When you purchase our products, we may collect certain personal information about you, either directly from you or through your local Toro company or dealer. Toro uses this information to fulfil contractual obligations - such as to register your warranty, process your warranty claim or to contact you in the event of a product recall - and for legitimate business purposes - such as to gauge customer satisfaction, improve our products or provide you with product information which may be of interest. Toro may share your information with our subsidiaries, affiliates, dealers or other business partners in connection these activities. We may also disclose personal information when required by law or in connection with the sale, purchase or merger of a business. We will never sell your personal information to any other company for marketing purposes.

### **Retention of your Personal Information**

Toro will keep your personal information as long as it is relevant for the above purposes and in accordance with legal requirements. For more information about applicable retention periods please contact [legal@toro.com](mailto:legal@toro.com).

### **Toro's Commitment to Security**

Your personal information may be processed in the US or another country which may have less strict data protection laws than your country of residence. Whenever we transfer your information outside of your country of residence, we will take legally required steps to ensure that appropriate safeguards are in place to protect your information and to make sure it is treated securely.

### **Access and Correction**

You may have the right to correct or review your personal data, or object to or restrict the processing of your data. To do so, please contact us by email at [legal@toro.com](mailto:legal@toro.com). If you have concerns about the way in which Toro has handled your information, we encourage you to raise this directly with us. Please note that European residents have the right to complain to your Data Protection Authority.



**Count on it.**