



Count on it.

Parts Catalog

Power Broom

Model No. 38701—Serial No. 411700000 and Up



Ordering Replacement Parts

To order replacement parts, please supply the part number, the quantity, and the description of each part desired.

Understanding Reference Numbers

Each identified part in an illustration has a reference number. The reference number for a part also appears in the parts list, along with other information about the part.

This catalog uses two special reference number formats, one to indicate parts in a service assembly and another to indicate the quantity of a given part in an illustration.

Service Assembly Reference Numbers

Parts in service assemblies have reference numbers in the form a:b. The a represents the reference number of the entire service assembly and the b represents a sequential number unique to each part within the service assembly.

For example, a wheel assembly might be identified by reference number 6, the tire by 6:1, the valve by 6:2, and the wheel by 6:3. When you order the assembly identified by reference number 6, you receive all parts identified by reference numbers 6:1, 6:2, and 6:3. However, you may also order any part individually. Reference numbers of this type appear in illustration and in parts lists.

Reference Numbers Indicating Quantity

In an illustration, if a reference number indicates more than one part, the reference number has the form nX y. The n represents the quantity of the part, the X is the multiplication symbol, and the y represents the reference number.

For example, in an illustration, the reference number 2X 37 means that two of the parts identified by reference number 37 are indicated.

Contents

Main Frame and Belt Cover Assembly	4
Auger Drive Assembly	6
Broom and Deflector Assembly	8
Broom Frame Assembly	10
Broom Assembly	12
Engine Assembly	14
Handle Assembly	16
Control Assembly	18
Traction Drive Assembly	20
Attachments and Accessories	22

Main Frame and Belt Cover Assembly

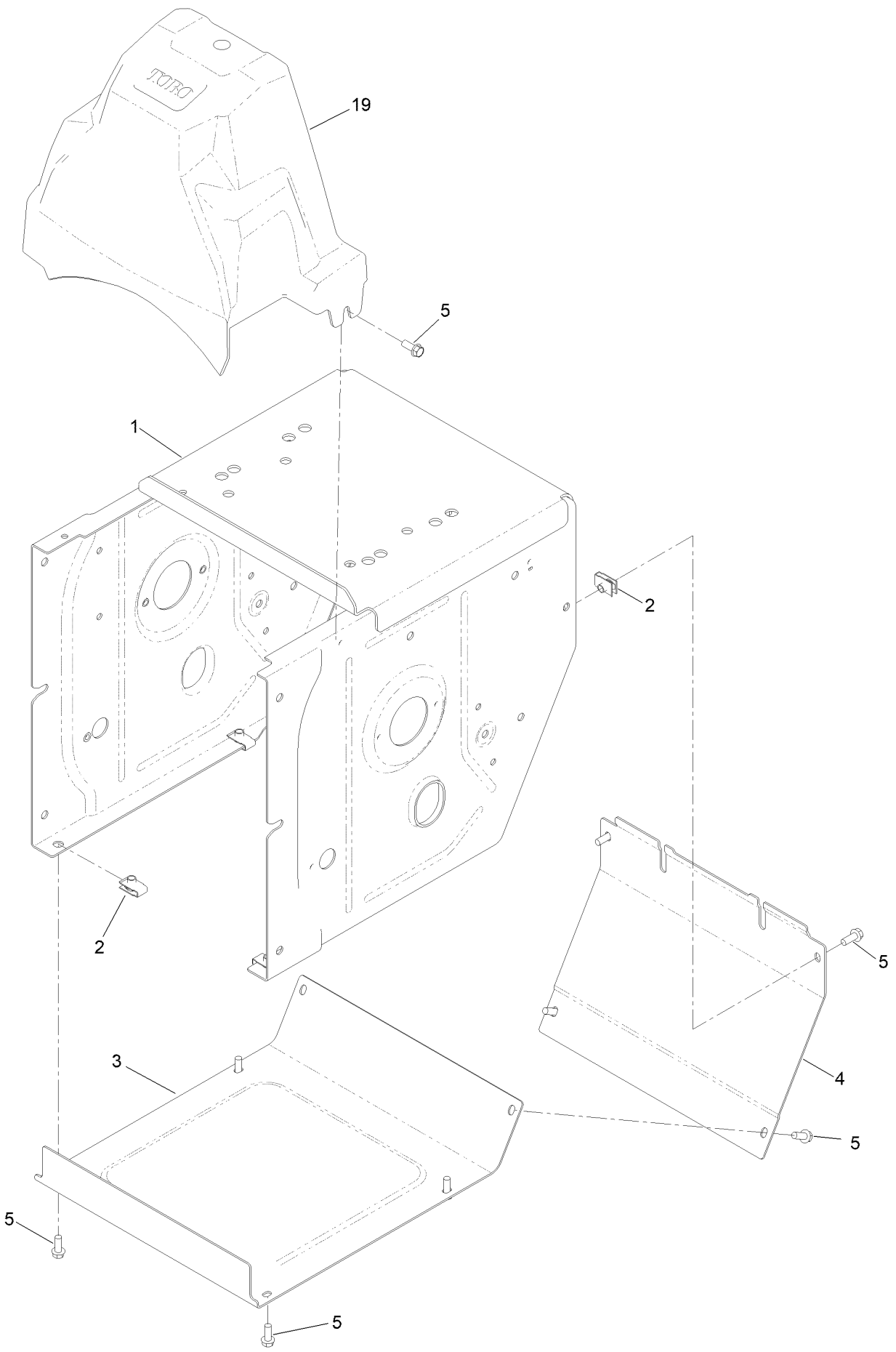

Main Frame and Belt Cover Assembly (continued)

<i>Ref.</i>	<i>Part Number</i>	<i>Qty.</i>	<i>Description</i>
1	136-6639-01	1	Frame-Traction
2	107069	8	Clip
3	136-6650-01	1	Cover-Bottom

<i>Ref.</i>	<i>Part Number</i>	<i>Qty.</i>	<i>Description</i>
4	136-6651-01	1	Cover-Rear
5	32144-85	10	Screw-HWH Thd Form
19	138-0731	1	Belt Cover, No Light

Auger Drive Assembly

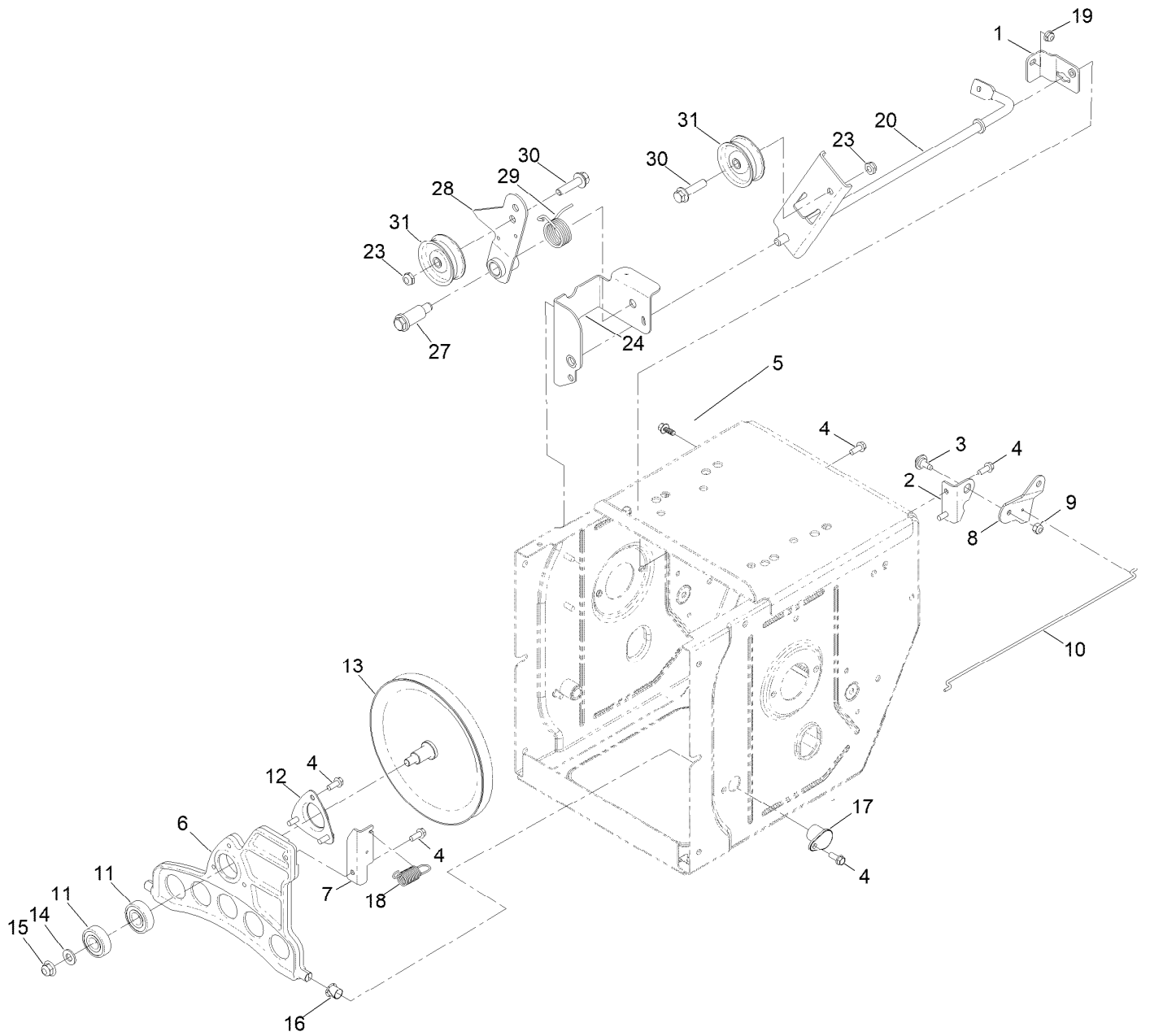

Auger Drive Assembly (continued)

<i>Ref.</i>	<i>Part Number</i>	<i>Qty.</i>	<i>Description</i>	<i>Ref.</i>	<i>Part Number</i>	<i>Qty.</i>	<i>Description</i>
1	136-8654-03	1	Bracket-Clutch, Impeller	15	119-4042	1	Nut-HF, NI
2	136-6654-03	1	Bracket- Bellcrank	16	256-257	2	Bushing-Nyliner
3	92-9698	1	Screw-Shoulder	17	120-7156	2	Bushing-Plate, Traction
4	32144-85	15	Screw-HWH Thd Form	18	137-6189	1	Spring-Extension
5	137-3111	1	Screw-HHF	19	137-3005	1	Nut-HF
6	136-6689	1	Plate-Friction, Wheel	20	145-0670	1	Arm-Clutch, Impeller
7	137-6156	1	Bracket-Plate, Traction	23	121-4600	2	Nut-Hex
8	137-6159-03	1	Bellcrank-Drive	24	136-8671-03	1	Bracket-Brake, Clutch
9	137-3094	1	Nut-Hex	27	136-7116	1	Bolt-Shoulder
10	137-6157	1	Link-Drive	28	136-7186	2	Arm-Idler, Traction
11	38-7820	2	Bearing-Ball	29	120-3060	1	Spring-Torsion
12	136-7124	1	Retainer-Bearing	30	139-2553	2	Screw-HHF
13	137-6154	1	Pulley-Traction	31	3-4244	2	Pulley-Idler
14	115-1166	1	Washer-Flat				

Broom and Deflector Assembly

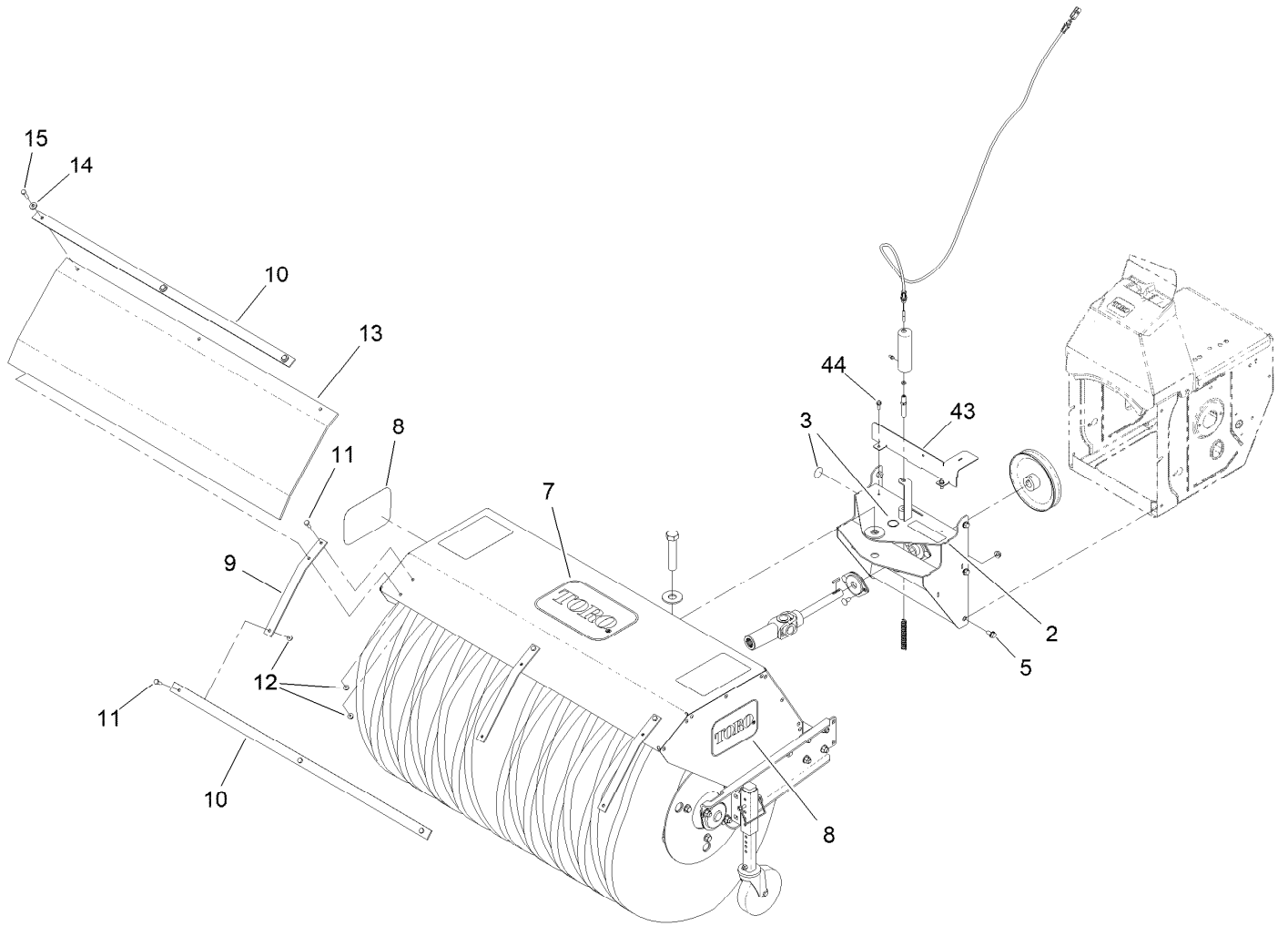

Broom and Deflector Assembly (continued)

<i>Ref.</i>	<i>Part Number</i>	<i>Qty.</i>	<i>Description</i>	<i>Ref.</i>	<i>Part Number</i>	<i>Qty.</i>	<i>Description</i>
2	112-9028	1	Decal-Cover, Missing	11	137-3042	6	Screw-HH
3	115-2903	2	Decal-Grease	12	104-7201	9	Nut-HF, NI
5	32144-14	6	Screw-HWHTF	13	116-8864	1	Deflector-Broom
7	66-6140	1	Decal	14	3256-2	3	Washer-Flat
8	142-3051	2	Decal-Z-Logo	15	120-4654	3	Screw-HHF
8	62-5550	2	Decal	43	139-9928-01	1	Plate-Cover
9	116-8869-03	3	Strap-Support, Deflector	44	32144-85	2	Screw-HWH Thd Form
10	116-8880-03	2	Strap-Support, Broom Deflector				

Broom Frame Assembly

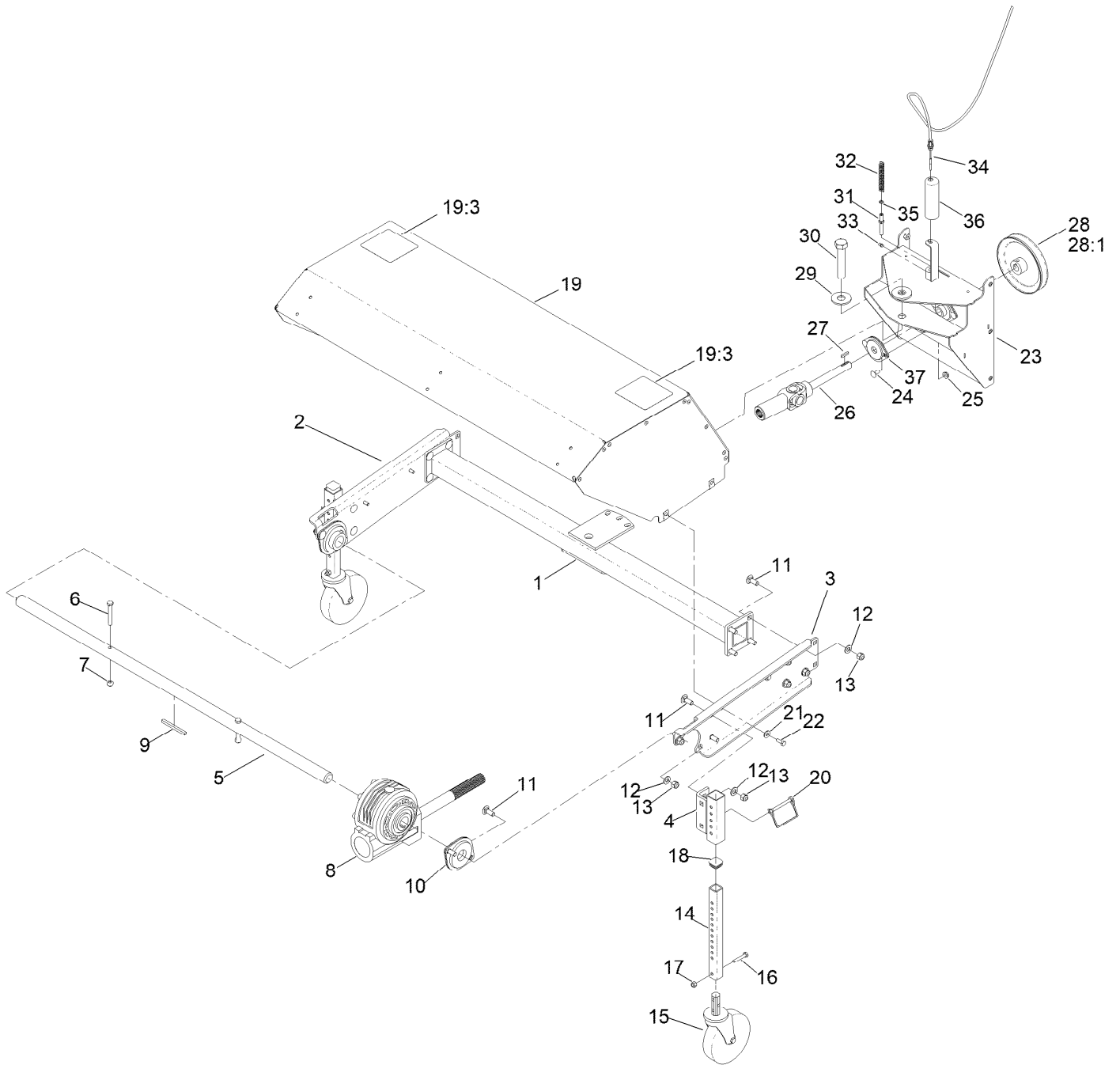

Broom Frame Assembly (continued)

<i>Ref.</i>	<i>Part Number</i>	<i>Qty.</i>	<i>Description</i>	<i>Ref.</i>	<i>Part Number</i>	<i>Qty.</i>	<i>Description</i>
1	116-8544	1	Frame	20	116-8224	2	Pin-Wire, Lock
2	116-8546	1	Arm-Right	21	120-9646	4	Washer-Flat
3	116-8545	1	Arm-Left	22	137-3042	4	Screw-HH
4	116-8543	2	Caster-Bracket	23	139-9942-01	1	Frame-Mounting [red]
5	116-8114	1	Shaft	24	3230-1	4	Bolt-CARR
6	120-9738	2	Screw-HH	25	32128-20	4	Nut-HF
7	119-4038	2	Nut-Hex	26	116-8104	1	Shaft-Drive
8	116-8115	1	Gearbox-Worm	27	116-8105	1	Key-Round End
9	83-2800	1	Key-Straight	28	116-7930	1	Pulley-Impeller
10	116-8116	2	Bearing-Flange	28:1	3246-18	2	Setscrew
11	139-2590	16	Screw-CARR	29	3256-8	1	Washer-Flat
12	115-1166	16	Washer-Flat	30	3216-7	1	Screw-HH
13	137-3087	16	Nut-Hex	31	116-8106	1	Pin-Swing
14	116-8223	2	Tube-Square, Height Adjust	32	116-8107	1	Spring-Compression
15	116-8117	2	Caster-Wheel	33	302-19	1	Fitting-Grease
16	137-3050	2	Screw-HH	34	116-7671	1	Cable-Angle, Broom
17	137-3088	2	Nut-Hex	35	3217-26	1	Nut-Hex
18	103-3202	2	Cap	36	116-8108	1	Cap
19	116-8123	1	Broom Hood ASM	37	116-8103	2	Bearing-Shaft
19:3	142-9656	2	Decal-Warning Fly Obj-Entangle				

Broom Assembly

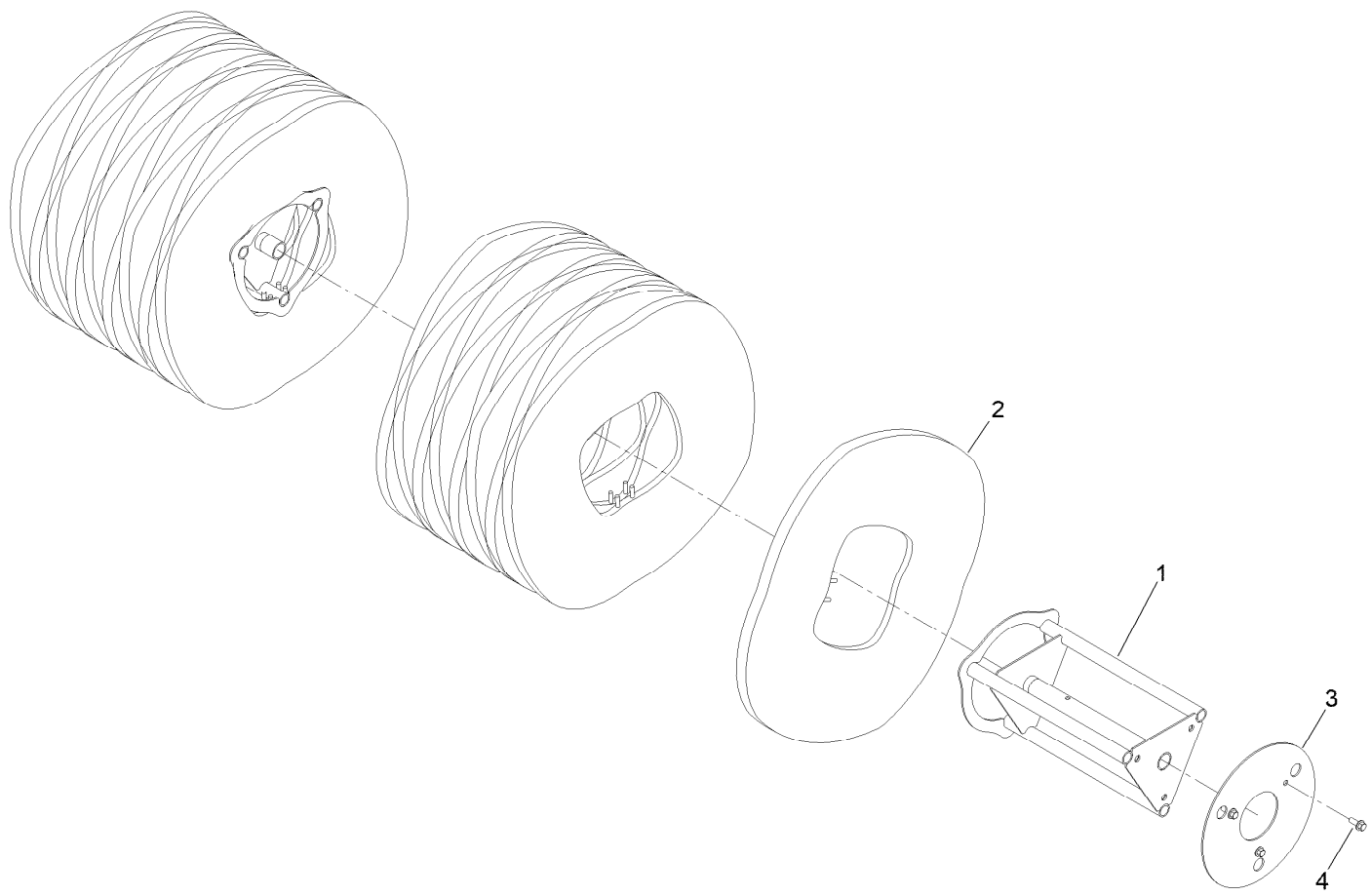

Broom Assembly (continued)

<i>Ref.</i>	<i>Part Number</i>	<i>Qty.</i>	<i>Description</i>	<i>Ref.</i>	<i>Part Number</i>	<i>Qty.</i>	<i>Description</i>
1	116-8119	2	Core-Broom	3	116-8121	2	Plate-End, Retainer
2	116-8120	18	Segment-Poly	4	139-2597	6	Screw-HHF

Engine Assembly

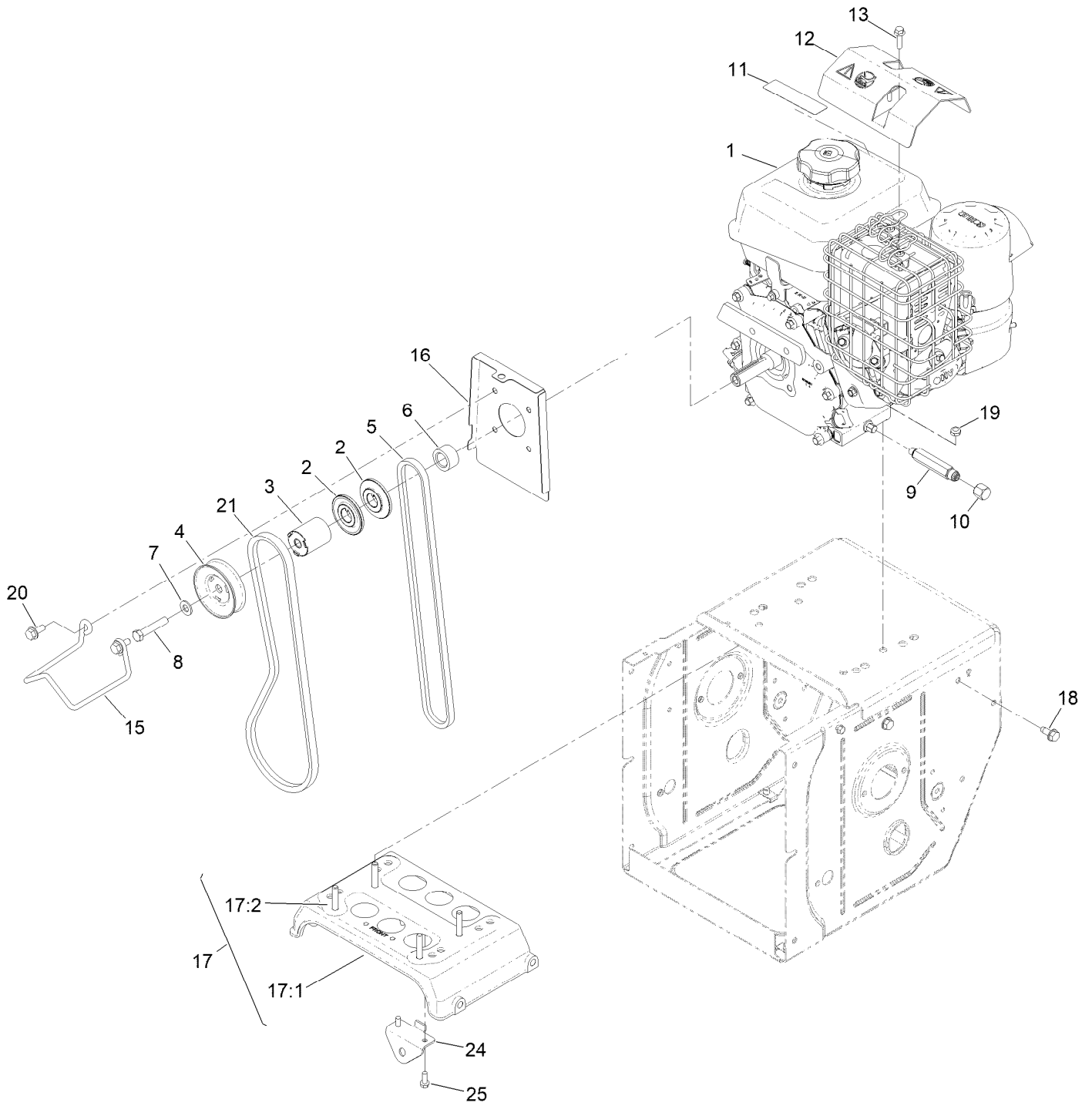

Engine Assembly (continued)

<i>Ref.</i>	<i>Part Number</i>	<i>Qty.</i>	<i>Description</i>	<i>Ref.</i>	<i>Part Number</i>	<i>Qty.</i>	<i>Description</i>
1		1	Engine-Kohler, Ch270 ●■	15	144-2816	1	Guide-Belt
2	144-1240	2	Sheave-Traction	16	140-7945-03	1	Cover-Crank
3	144-1241	1	Spacer-Pulley	17	144-1625	1	Engine Plate ASM (G250)
4	137-6179	1	Pulley-Impeller	17:1	144-1626	1	Plate-Engine
5	109-7299	1	Belt,3L P21 Drive	17:2	136-7178	4	Stud-Press 95/16-18 X 1.625)
6	144-1242	1	Spacer	18	32144-70	4	Screw-HWHTF
7	115-1166	1	Washer-Flat	19	137-3089	4	Nut-Hex
8	120-2302	1	Screw-HH	20	138-0690	2	Screw-HH
9	116-8721	1	Adapter	21	80-3590	1	V-Belt
10	01-201-4520	1	Cap	24	136-6644-03	1	Bracket-Control, Traction
11	133-8062	1	Decal-Arrestor, Spark	25	32144-85	2	Screw-HWH Thd Form
12	126-4178-03	1	Deflector-Debris, Muffler				
13	33103-025	1	Screw-HHF				

● Not serviced separately

■ Obtain parts from www.kohlerplus.com

Handle Assembly

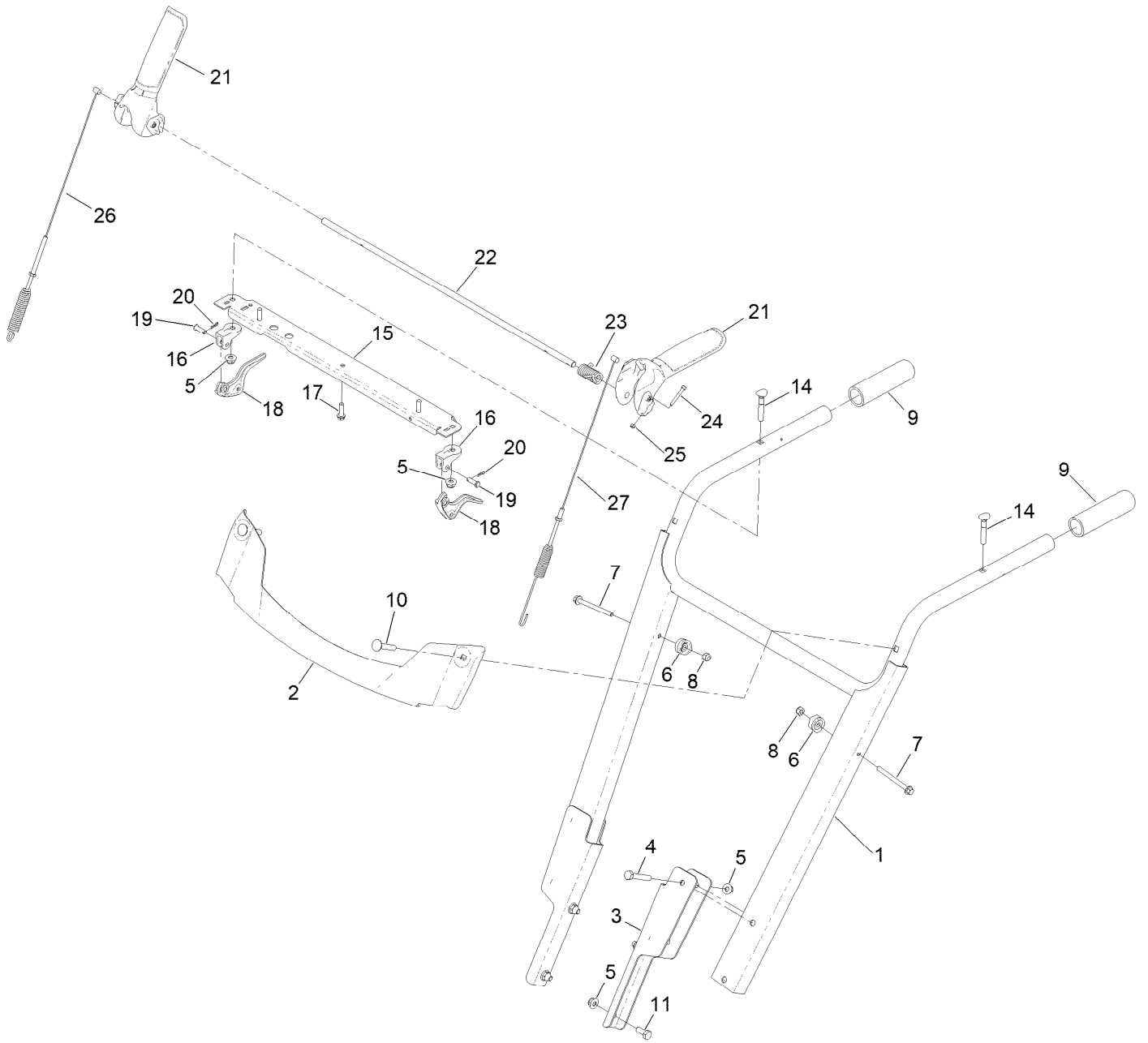

Handle Assembly (continued)

<i>Ref.</i>	<i>Part Number</i>	<i>Qty.</i>	<i>Description</i>	<i>Ref.</i>	<i>Part Number</i>	<i>Qty.</i>	<i>Description</i>
1	137-6224-03	1	HD Handle ASM	17	137-3099	3	Screw-Plastite, HWH
2	137-6233-01	1	Trim-Metal, HD	18	106-4505	2	Lever-Clutch
3	137-6221-03	2	Bracket-Handle, Lower	19	1-808265	2	Pin-Clevis
4	120-9686	4	Screw-HH	20	108-2992	2	Pin-Hair
5	138-8401	12	Nut-HF	21	137-6171	2	Lever-Control
6	106-4509	2	Clamp-Cable	22	144-1343	1	Rod-Lockout
7	138-3653	2	Screw-HHF	23	138-0678	1	Spring-Torsion, Handle Return
8	137-3094	2	Nut-Hex	24	145-0660	2	Screw-HSH,Spl
9	120-1333	2	Grip-Handle	25	131-8641	2	Nut-Lock
10	138-8402	2	Bolt-CARR	26	138-3661	1	Cable-Auger
11	137-3052	4	Screw-HH	27	138-0728	1	Cable-Traction
14	137-3107	2	Screw-Handle	99	130-8332	1	Adhesive-Loctite 608 ●
15	145-4075-01	1	Brace-Console				
16	105-9980	2	Mount-Lever, Clutch				

● Not illustrated

Control Assembly

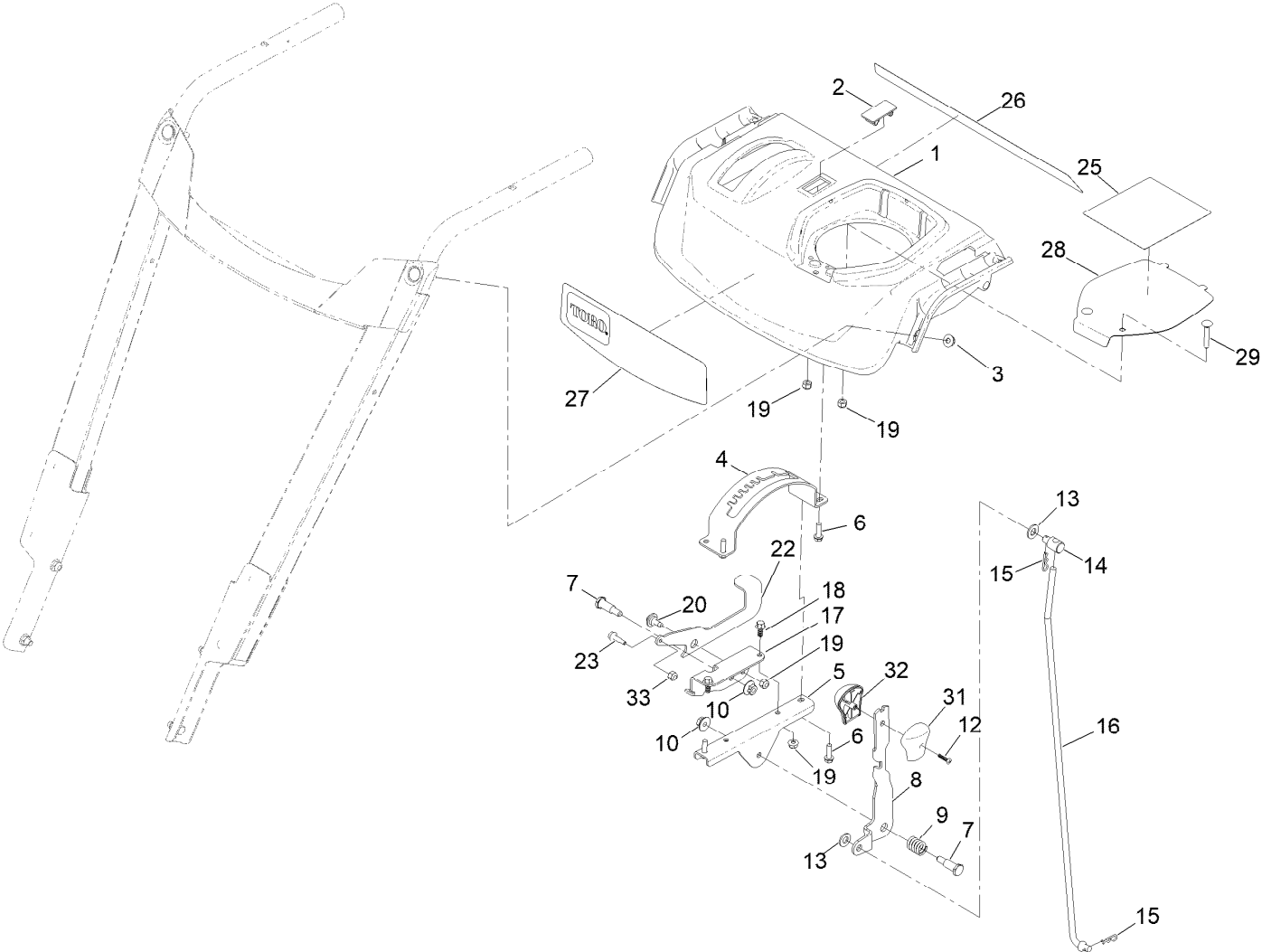

Control Assembly (continued)

<i>Ref.</i>	<i>Part Number</i>	<i>Qty.</i>	<i>Description</i>	<i>Ref.</i>	<i>Part Number</i>	<i>Qty.</i>	<i>Description</i>
1	144-1346	1	Panel-Control	17	139-9919-03	1	Bracket-Lever, Broom Angle
2	99-7420	1	Plug-Hole	18	137-3111	2	Screw-HHF
3	138-8401	7	Nut-HF	19	119-4040	5	Nut-HF, NI
4	137-6187-03	1	Gate-Shift	20	92-9698	1	Screw-Shoulder
5	137-6188-03	1	Bracket-Shift	22	139-9920-03	1	Lever-Broom Angle
6	137-3099	4	Screw-Plastite, HWH	23	139-1709	1	Screw-Shoulder
7	137-3103	2	Screw-Shoulder, HH	25	142-9546	1	Decal-Warning
8	137-6231-03	1	Selector-Speed	26	144-0316	1	Decal-Control Panel
9	136-7121	1	Spring-Compression	27	144-0315	1	Decal-Console
10	137-3038	2	Nut-HF	28	139-9927-03	1	Plate-Cover, CONT Pnl
12	94-4496	1	Screw-PPH	29	137-3011	2	Bolt-CARR
13	115-1166	2	Washer-Flat	31	105-9999	1	Knob-Shift, LH
14	136-7193	1	Trunnion-Rod	32	106-4423	1	Knob-Shift, RH
15	137-3083	2	Pin-Hair	33	138-0719	1	Nut-HF
16	137-6225	1	Rod-Shift				

Traction Drive Assembly (continued)

<i>Ref.</i>	<i>Part Number</i>	<i>Qty.</i>	<i>Description</i>	<i>Ref.</i>	<i>Part Number</i>	<i>Qty.</i>	<i>Description</i>
1	136-6668	1	LH Wheel And Tire ASM	25:2	108-2973	2	Bushing-Flange
2	136-6667	1	RH Wheel And Tire ASM	26	108-0015	4	Washer-Flat
3	125-1135	1	Shaft-Hex	27	107-8895	2	32T Sprocket ASM
4	108-7319	2	Retainer-Bearing	27:2	108-2973	2	Bushing-Flange
5	32144-85	6	Screw-HWH Thd Form	28	107-8885	6	Spring-Compression
6	32121-9	2	Pin-Roll, Slotted	29	107-8899	6	Pin-Dowel
7	137-6162	1	Shift Rod	30	107-8879	6	Pawl-Clutch
8	119-7684	1	Spacer-Plate, Shift	31	107-8889	4	Guide-Collar
9	121-6835	1	Bearing-Ball	32	136-6648-03	1	Brace-Shift, Collar
10	32144-86	1	Screw-HWHTF	33	138-3653	2	Screw-HHF
11	137-3091	4	Nut-Hex	34	119-4040	2	Nut-HF, NI
12	119-7630	1	Trunnion	35	107-8887	1	Collar-Shift, LH
13	119-1567	1	Wheel-Friction	36	107-8888	1	Collar-Shift, RH
14	137-6246	3	Screw-Shoulder	37	107-8891	2	Washer-Thrust
15	136-6640	2	Axle	38	108-0016	2	Chain-Roller
16	106-7259	1	Tube-Axle	39	107-8893	2	Spring-Extension
17	137-3051	1	Screw-HH	40	107-8880	6	Support-Pawl
18	137-3089	1	Nut-Hex	41	137-3010	12	Screw-BHCS
19	136-6641	2	Bushing-Axle	42	136-7318	2	Retainer-Pawl, Pin
20	138-0725	2	Washer-Thrust	43	107-8896	2	Cable-Clutch
21	136-6642	2	Gear-Axle	44	136-6647-03	1	Retainer-Rod, Shift
22	138-0720	2	Bolt-Shoulder, HSH	45	125-1134	2	Gear-Pinion, 8 Tooth
23	137-3093	2	Nut-Hex	46	36-4780	2	Washer-Plain
24	107-8883	1	Shaft-Intermediate	47	32144-14	2	Screw-HWHTF
25	107-8894	2	11T Gear ASM	48	138-3642	2	Pin-Klik

Attachments and Accessories

For 38701 Power Broom

Product Name	Model/Part
Dirt Deflector Kit.....	116-8229
Black Snow/Ice Wafers	116-8232
Yellow Turf Wafers	116-8233
Kit-Caster, Turf Broom	135-2311
Kit-Cab.....	139-1640
Tire Chain Kit, 16in Tires.....	38215

Notes:



Count on it.