



Z153

Z-Master[®] with 52" Side Discharge Mower

Model No. 74198—22000001 and Up

Parts Catalog

Ordering Replacement Parts

To order replacement parts, please supply: the part number, the quantity, and the description of each part desired.

Understanding Reference Numbers

Each identified part in an illustration has a reference number. The reference number for a part also appears in the parts list, along with other information about the part.

This catalog uses two special reference number formats, one to indicate parts in a service assembly and another to indicate the quantity of a given part in an illustration.

Service Assembly Reference Numbers

Parts in service assemblies have reference numbers in the form **a:b**. The **a** represents the reference number of the entire service assembly and the **b** represents a sequential number unique to each part within the service assembly.

For example, a wheel assembly might be identified by reference number **6**, the tire by **6:1**, the valve by **6:2**, and the wheel by **6:3**. When you order the assembly identified by reference number **6**, you receive all parts identified by reference numbers **6:1**, **6:2**, and **6:3**. However, you may also order any part individually.

Reference numbers of this type appear in illustrations and in part lists.

Reference Numbers Indicating Quantity

In an illustration, if a reference number indicates more than one part, the reference number has the form **nX y**. The **n** represents the quantity of the part, the **X** is the multiplication symbol, and the **y** represents the reference number.

For example, in an illustration, the reference number **2X 37** means that two of the parts identified by reference number **37** are indicated.

Contents

Description	Page	Description	Page
Front Frame Assembly	3	Valve/Camshaft Assembly	
Height of Cut Assembly	5	Kawasaki FH680V-CS10	20
Main Frame Assembly	6	Cooling-Equipment Assembly	
Fuel System Assembly	7	Kawasaki FH680V-CS10	21
Parking Brake System Assembly	8	Electric-Equipment Assembly	
Motion Control System Assembly	9	Kawasaki FH680V-CS10	22
Hydraulic System Assembly	10	Control-Equipment Assembly	
Pump, Idler and Belt Assembly	11	Kawasaki FH680V-CS10	23
Engine and Clutch Assembly	12	Carburetor Assembly	
Deck Assembly	13	Kawasaki FH680V-CS10	24
Deck Spindle Assembly	14	Lubrication-Equipment Assembly	
Idler, Pulley/Lift Strut, Chain Assembly	15	Kawasaki FH680V-CS10	25
Electrical System Assembly	16	Air Filter/Muffler Assembly	
Electrical Schematic	17	Kawasaki FH680V-CS10	26
Piston/Crankshaft Assembly		Fuel-Tank/Fuel Valve Assembly	
Kawasaki FH680V-CS10	18	Kawasaki FH680V-CS10	27
Cylinder/Crankcase Assembly		Starter/Decals Assembly	
Kawasaki FH680V-CS10	19	Kawasaki FH680V-CS10	28

Accessories

Description	Model / Part No.	Description	Model / Part No.
52" Deck Recycler Kit	59225	4 Post ROPS Kit	79470
52" Mulching Kit	59227	Hitch Kit	99-8924
52" Striping Kit	30121	Z-Stand Kit	105-1621
Seat-Suspension, High	99-8522	Steel Bagger	30107
Blade Assembly-Atomic 18	104-1301		

Part Description Abbreviations

Part descriptions in this catalog may include the following abbreviations.

Abbreviation	Meaning	Abbreviation	Meaning
AR	as required	HYD	hydraulic
ASM	assembly	INC	incorporated
CARR	carriage	LH	left hand
DEG	degrees	NI	nylon insert
FH	flat head	PPH	Phillips pan head
GA	gauge	PTH	Phillips truss head
HF	hex flange	PTO	power take off
HH	hex head	RH	right hand
HHF	hex head flange	SFH	slotted fillister head
HLH	hex lag head	SHH	slotted hex head
HJ	hex jam	SQH	square head
HOC	height-of-cut	SHWH	slotted hex washer head
HS	hex socket	SPH	slotted pan head
HSBH	hex socket button head	SRH	slotted round head
HSFH	hex socket flat head	STD	standard
HSH	hex socket head	TAP	self tapping
HWH	hex washer head	TTH	Torx truss head
HWHTF	hex washer head thread forming	WH	wing head

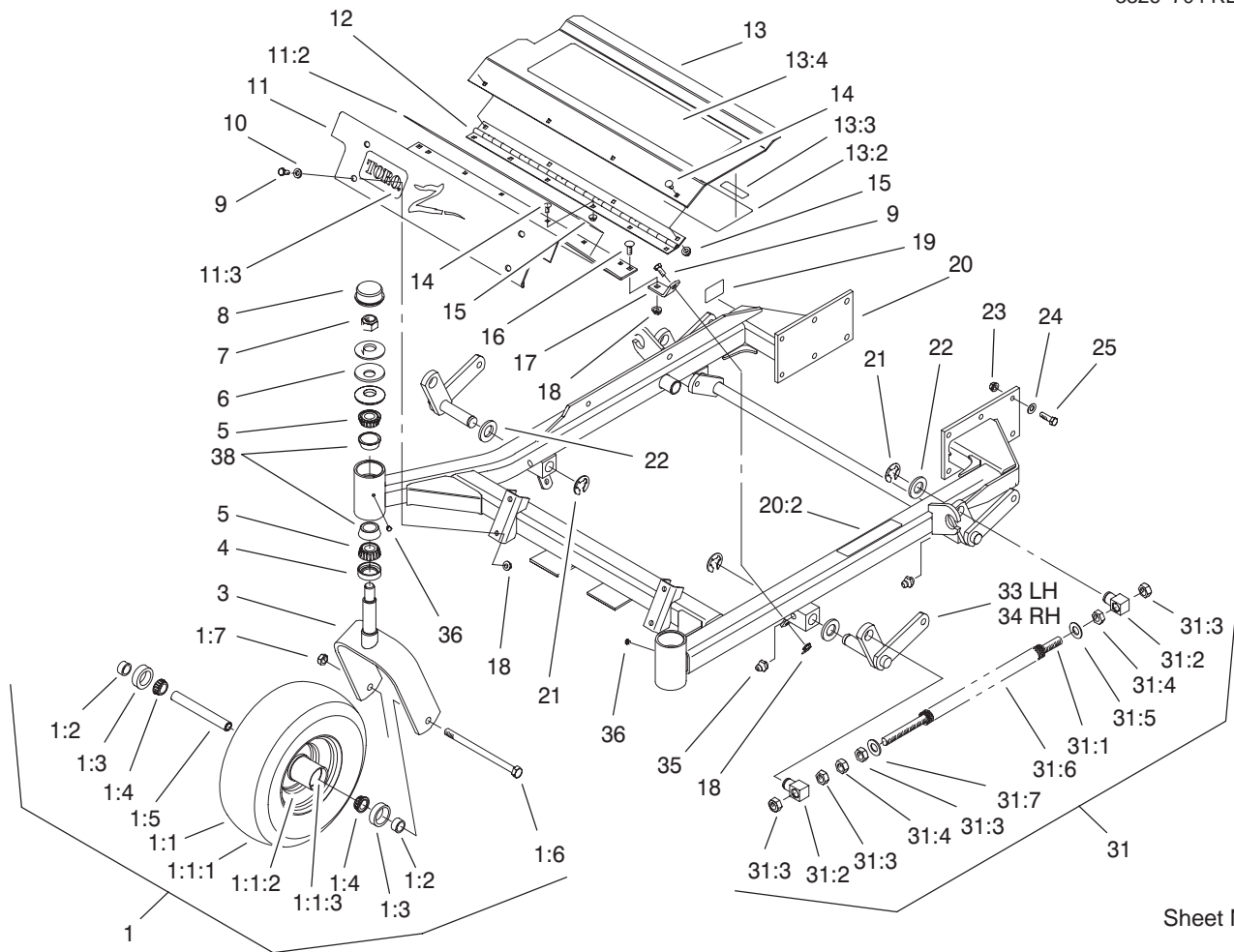

Sheet No.: 2

Front Frame Assembly

Ref. No.	Part No.	Qty.	Description
1	1-634662	2	Caster Wheel ASM
1:1	1-633582	1	Wheel & Tire ASM
1:1:1	1-633002	1	Tire
1:1:2	1-633583	1	Wheel
1:1:3	1-633584	2	Bearing-Cup
1:2	1-633581	2	Spacer-Bearing
1:3	1-633580	2	Seal-Bearing
1:4	1-633585	2	Bearing-Cone, Taper
1:5	1-633579	1	Spacer-Caster, Front
1:6	325-36	1	Screw-HH
1:7	3296-45	1	Nut-Lock, NI
3	1-632511-01	2	Caster
4	1-543511	2	Seal-Grease
5	254-94	4	Bearing-Cone, Taper
6	1-633508	6	Washer-Bellville
7	3296-51	2	Nut-Lock, NI
8	1-543513	2	Cap-Grease
9	322-3	6	Screw-HH
10	3256-23	4	Washer-Flat
11	99-3940	1	Floorpan-Front
11:2	1-633553	1	Pad-Antiskid
11:3	1-633737	1	Decal-Z-Master
12	1-653049	1	Hinge-Floorpan
13	99-3930	1	Footrest ASM
13:2	99-3924	1	Decal-Service
13:3	98-5954	1	Decal-Missing, Cover

Ref. No.	Part No.	Qty.	Description
13:4	1-633553	1	Pad-Antiskid
14	3229-10	10	Screw-CARR
15	32128-33	10	Nut-HF
16	3230-1	2	Screw-CARR
17	99-3870-01	2	Bracket-Floorpan
18	32128-20	8	Nut-HF
19	105-2625	1	Decal-Safety STD
20	99-3931	1	Front Frame ASM
20:2	1-633818	1	Decal-Warning
21	32151-103	6	Ring-Snap
22	3256-29	6	Washer-Flat
23	3290-357	12	Nut-HHF
24	98-5975	12	Washer-Belleville
25	323-7	12	Screw-HH
31	103-1987	2	ASM,Front Spring
31:1	1-653011	1	Rod-Lift, Deck
31:2	1-633441	2	Swivel-Deck Mount, Rear
31:3	3217-11	4	Nut-Hex
31:4	3218-6	2	Nut-Jam
31:5	1-805517	1	Washer
31:6	1-653009	1	Spring-Compression
31:7	3256-27	1	Washer-Flat
33	99-3871-01	1	LH Lift Arm ASM
34	99-3872-01	1	RH Lift Arm ASM
35	302-19	4	Fitting-Grease

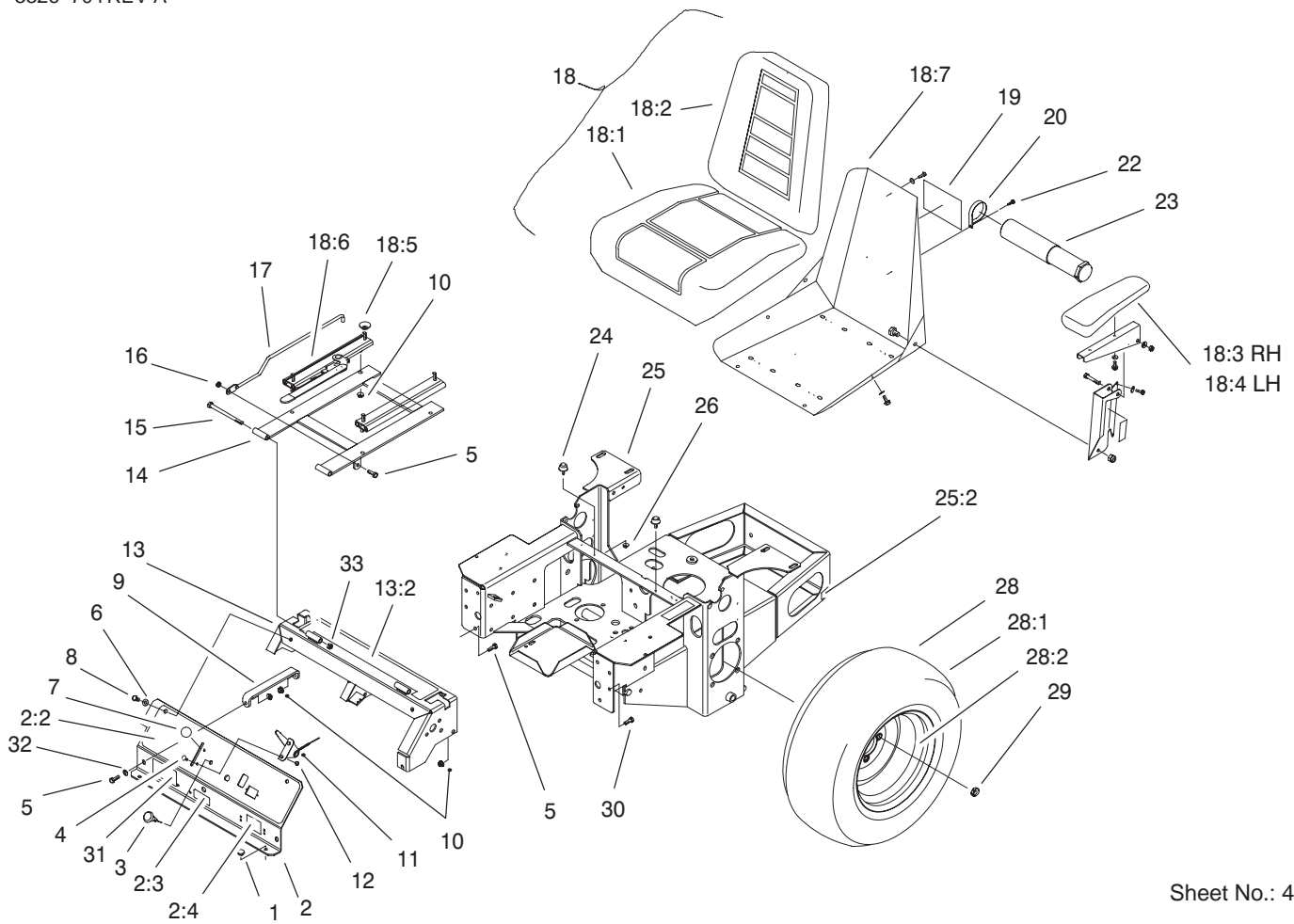

Sheet No.: 4

Main Frame Assembly

Ref. No.	Part No.	Qty.	Description
1	1-513658	2	Bumper-Catcher, Grass
2	99-3932	1	Control Panel ASM
2:2	99-3942	1	Decal-Panel, Control
2:3	103-0262	1	Decal-Valve, Fuel
2:4	98-4387	1	Decal-Protection, Ear
3	1-603336	1	Control-Choke
4	1-807513	2	Bolt-CARR
5	322-5	3	Screw-HH
6	3256-23	2	Washer-Flat
7	1-513592	1	Knob-Ball, Red
8	322-3	3	Screw-HH
9	1-653089-03	1	Bracket
10	32128-20	12	Nut-HF
11	1-633696	1	Cable-Throttle
12	3296-2	2	Nut-Lock
13	105-6123	1	Console ASM
13:2	103-1997	1	Decal-Top Console
14	1-632187-03	1	Frame-Seat
15	323-39	2	Screw-HH
16	3296-29	1	Nut-Lock, NI
17	103-1731	1	Rod, Seat Retainer
18	1-633705	1	Seat W/Tracks
18:1	103-0290	1	Cushion-Bottom, Seat
18:2	104-7754	1	Cushion-Back, Seat
18:3	1-633710	1	Cushion-Armrest, RH

Ref. No.	Part No.	Qty.	Description
18:4	1-633711	1	Cushion-Armrest, LH
18:5	1-543401	4	Spacer-Track
18:6	1-643255	1	Grip-Track, Seat
18:7	1-633859	1	Frame-Seat
19	99-4693	1	Decal-Toro
20	2412-120	2	R-Clamp
22	32104-76	2	Screw
23	74-0720	1	Tube-Manual
24	1-523420	2	Bumper
25	105-6121	1	Main Frame ASM
25:2	65-2690	2	Decal-Surface, Hot
26	3296-42	2	Nut-Lock, NI
28	1-653159	2	ASM, Wheel & Tire
28:1	1-653160	1	Tire
28:2	1-653161	1	Wheel
29	242-50	8	Nut-Lug
30	322-2	6	Screw-HH
31	100-3969	1	Decal-Z153
32	3256-3	2	Washer-Flat
33	3296-39	2	Nut-Lock, NI

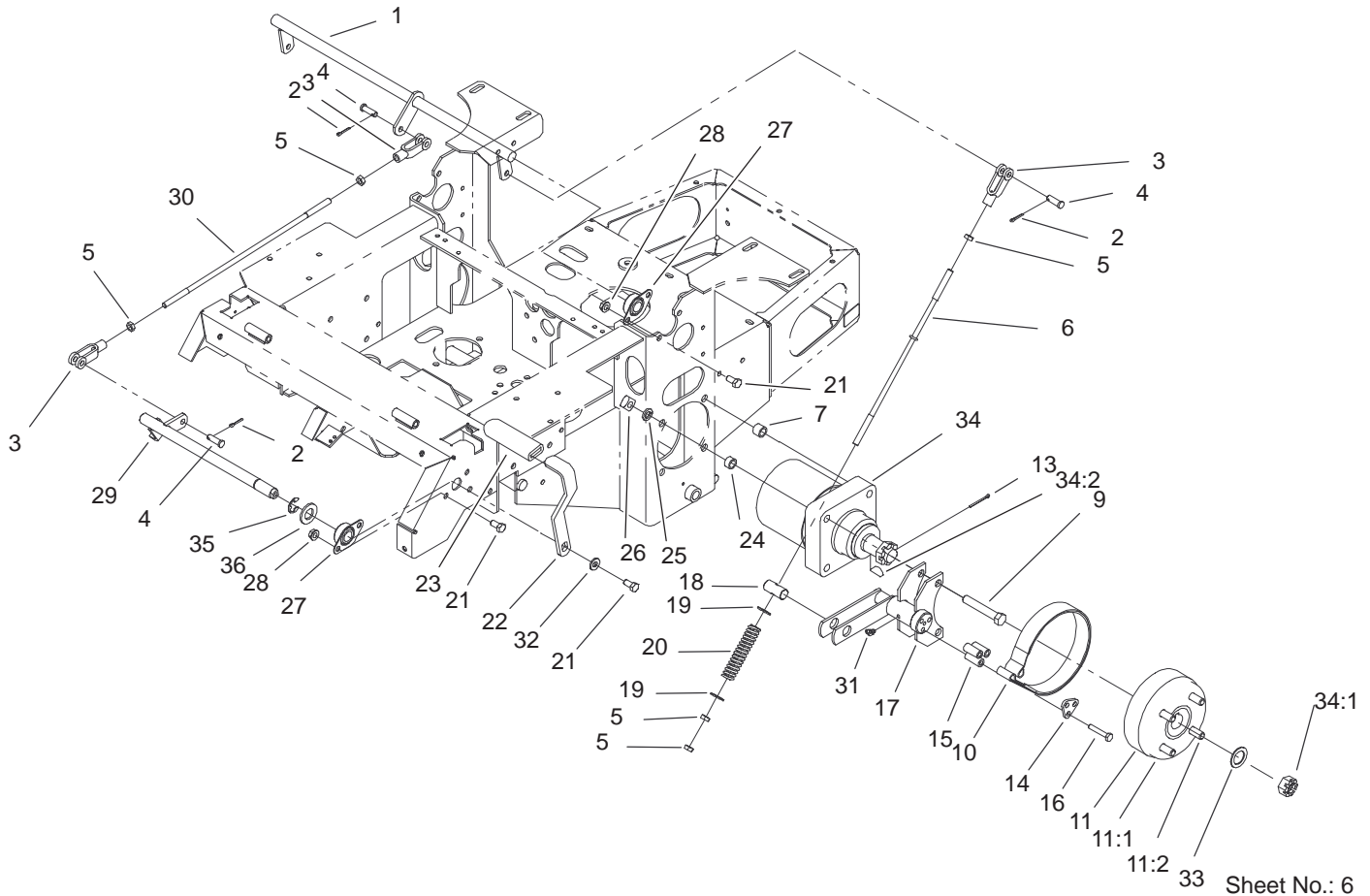

Sheet No.: 6

Parking Brake System Assembly

Ref. No.	Part No.	Qty.	Description
1	1-652073-03	1	Crank-Brake, Park
2	3272-10	4	Pin-Cotter
3	1-633131	4	Yoke-Linkage, Brake
4	1-808285	4	Pin-Clevis
5	3219-3	8	Nut-HH
6	103-0356	2	Rod-Brake
7	1-653068	4	Spacer-Wheel
9	325-13	8	Screw-HH
10	103-0355	2	Band-Brake
11	103-0590	2	Hub-Wheel W/Studs
11:1	103-0589	1	Hub-Wheel
11:2	1-633926	4	Stud-Wheel
13	1-806800	2	Pin-Cotter
14	103-0374	2	Retainer-Band, Brake
15	103-0384	6	Spacer
16	322-9	6	Screw-HH
17	103-0352-03	2	Bracket-Brake
18	1-633144	2	Pin-Trunion
19	3256-4	4	Washer-Flat
20	1-633454	2	Spring-Brake
21	323-4	9	Screw-HH
22	1-653074-03	1	Handle-Brake, Park
23	1-633268	1	Grip-Lever, Brake
24	1-653069	4	Spacer-Wheel
25	3253-7	8	Washer-Lock
26	103-0131	8	Nut-Square

Ref. No.	Part No.	Qty.	Description
27	1-633102	4	Bearing-Flange, Side
28	3290-357	8	Nut-HHF
29	1-652085	1	Shaft-Brake, Parking
30	1-653061	1	Linkage-Handle, Brake
31	1481	2	Fitting-Grease
32	98-5975	1	Washer-Belleville
33	1-523157	2	Washer-Spacer
34	1-523328	2	Motor-Wheel
34:1	1-809036	1	Nut-HH
34:2	3257-42	1	Key-Woodruff
*34:99	1-000099	1	Kit-Seal
*34:99	1-000139	1	Kit-Bearing
35	32151-48	1	E-Ring
36	3256-28	1	Washer-Flat

* Not illustrated

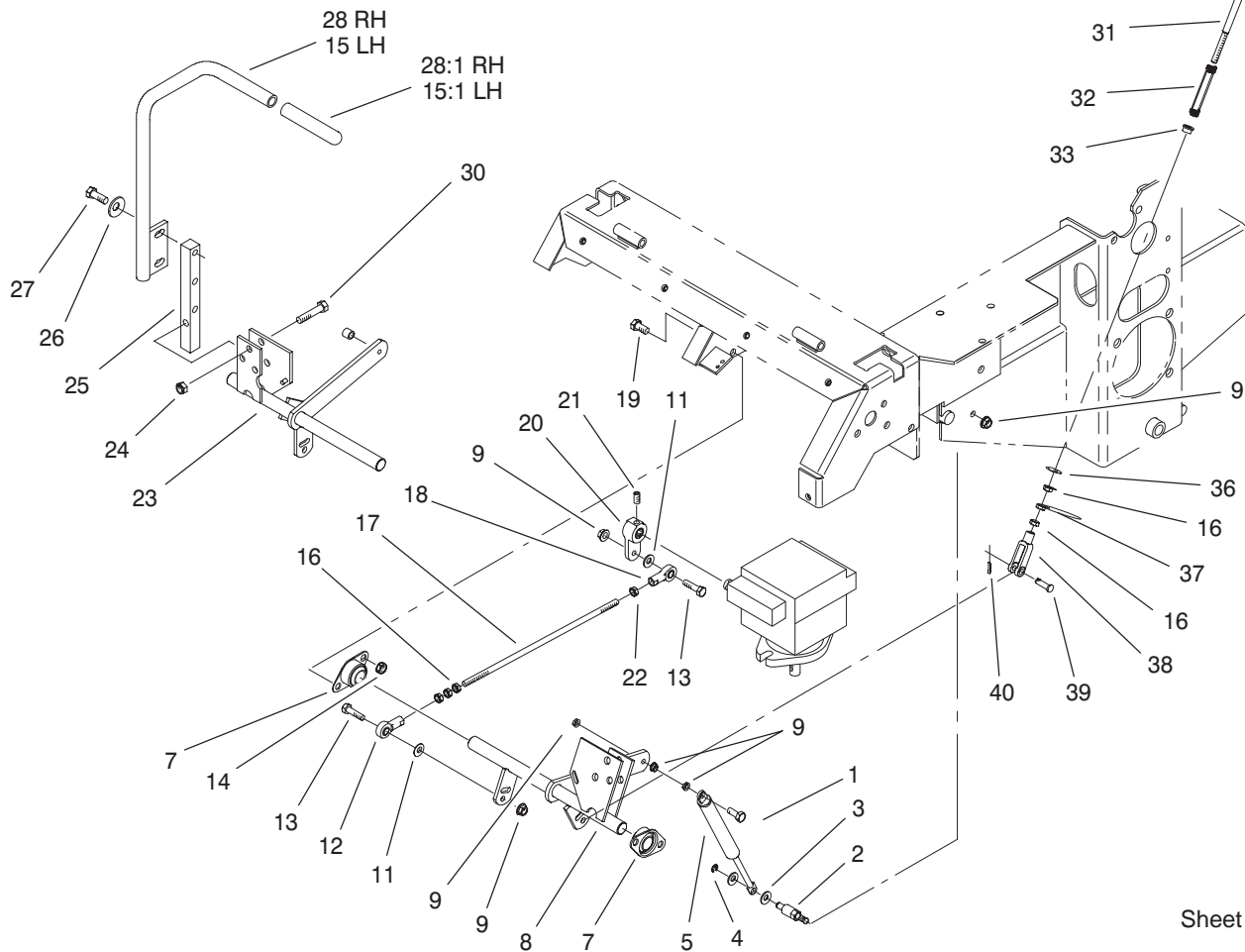

Sheet No.: 7

Motion Control System Assembly

Ref. No.	Part No.	Qty.	Description	Ref. No.	Part No.	Qty.	Description
1	1-403180	2	Screw-HH	26	98-5975	4	Washer-Belleville
2	1-653316	2	Pin-Dampner	27	323-6	4	Screw-HH
3	3256-23	4	Washer-Flat	28	103-0632	1	RH Lever ASM
4	32120-35	2	E-Ring	28:1	1-633257	1	Grip-Control, Motion
5	1-523027	2	Damper-Control	30	323-9	6	Screw-HH
7	1-633102	4	Bearing-Flange, Side	31	1-603737	2	Bolt-Return, Neutral
8	103-2199	1	LH Motion Control ASM	32	1-603807	2	Spring-Return, Neutral
9	32128-20	12	Nut-HF	33	1-603735	2	Bushing-Flanged
11	3256-3	4	Washer-Flat	36	3256-2	2	Washer-Flat
12	1-543017	2	Balljoint-RH	37	3220-2	2	Nut
13	322-6	4	Screw-HH	38	1-303105	2	Yoke-Adjustable
14	3290-357	8	Nut-HHF	39	1-808280	2	Pin-Clevis
15	103-0631	1	LH Lever ASM	40	3272-5	2	Pin-Cotter
15:1	1-633257	1	Grip-Control, Motion				
16	3219-2	10	Nut-Hex				
17	1-653046	2	Linkage-Pump/Lever				
18	1-633152	2	Balljoint-Thread, LH				
19	323-4	8	Screw-HH				
20	1-653092	2	Arm-Control, Pump				
21	1-803022	2	Screw				
22	1-804524	2	Nut				
23	103-2200	1	RH Motion Control ASM				
24	3296-39	6	Nut-Lock, NI				
25	103-0407	2	Arm-Shaft, Control				

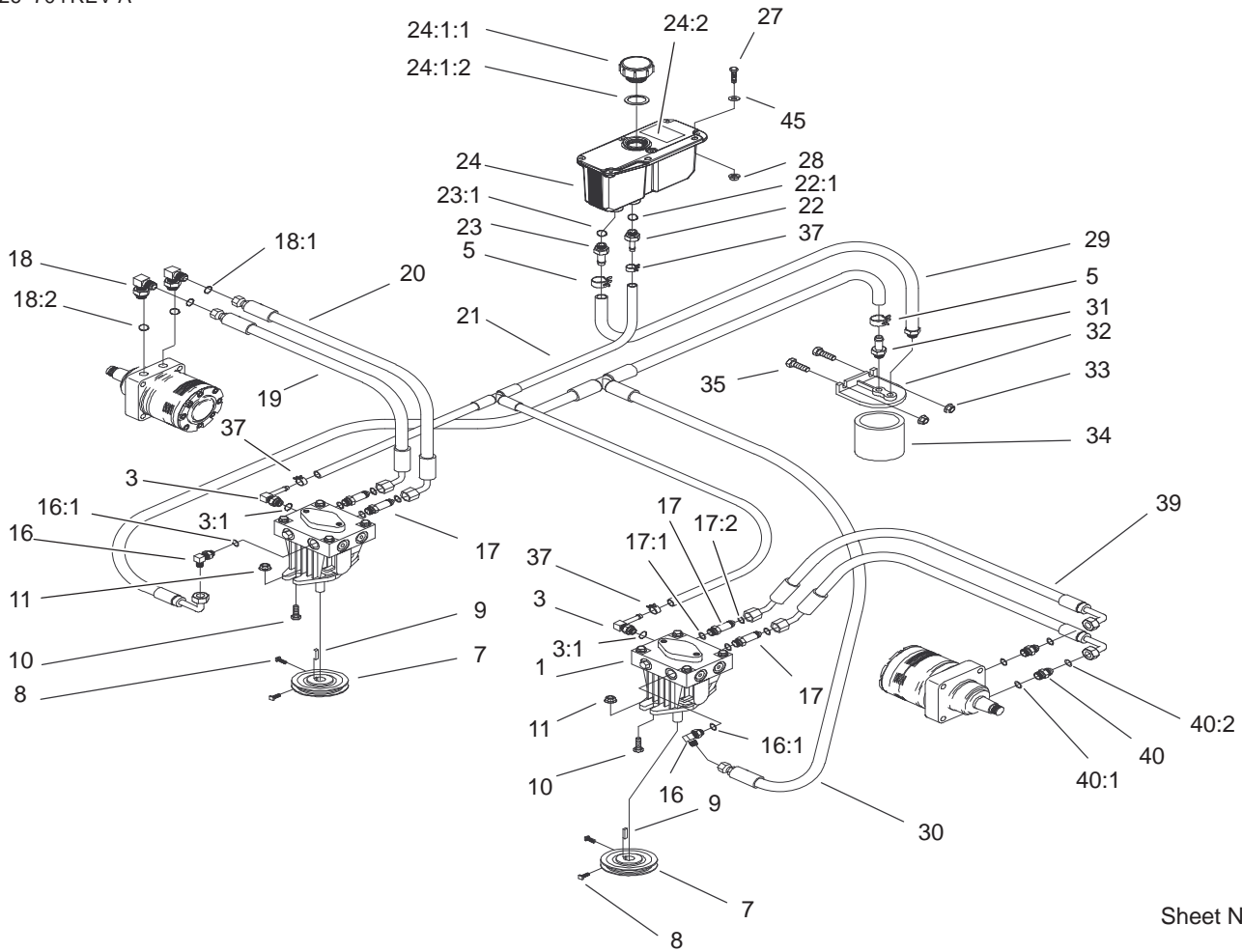

Sheet No.: 8

Hydraulic System Assembly

Ref. No.	Part No.	Qty.	Description
1	103-1942	2	Pump-Hydraulic
3	103-1799	2	Elbow-90°
3:1	237-42	1	O-Ring
5	103-1988	2	Clamp-Hose
7	1-413010	2	Sheave,4.25 W/Hub
8	1-803050	4	Screw-Set
9	1-807272	2	Key-Machine
10	323-7	4	Screw-HH
11	3290-357	4	Nut-HHF
16	103-1802	2	Elbow-90°
16:1	237-42	1	O-Ring
17	103-1940	4	Adapter,Straight
17:1	237-79	1	O-Ring
17:2	1-603992	1	O-Ring
18	1-633605	2	Fitting-Connector
18:1	1-603992	1	O-Ring
18:2	237-80	1	O-Ring
19	1-653186	1	Hose,Front
20	1-653187	1	Hose,RH Rear
21	103-1800	1	HYD Hose ASM
22	103-1801	1	Adapter-Straight
22:1	237-42	1	O-Ring
23	103-1912	1	Adapter,Straight
23:1	237-42	1	O-Ring
24	103-1947	1	HYD Reservoir ASM
☆24:1		1	HYD Reservoir ASM

Ref. No.	Part No.	Qty.	Description
24:1:1	103-1948	1	Cap-Tank, Hydraulic
24:1:2	103-1949	1	Gasket,Tank Cap
24:2	1-523552	1	Decal-Tank, Hydraulic
27	321-14	2	Screw-HH
28	32128-33	2	Nut-HF
29	103-1805	1	HYD Hose ASM
30	103-1803	1	HYD Hose ASM
31	103-1804	1	Adapter-Straight
32	1-603720	1	Head-Filter
33	32128-20	2	Nut-HF
34	1-633750	1	Filter-HYD
34	1-633752	1	Filter-HYD, Winter
35	322-5	2	Screw-HH
37	103-1716	3	Clamp-Hose
39	103-1680	2	Hose-LH
40	1-603991	2	Fitting-Straight
40:1	237-80	1	O-Ring
40:2	1-603992	1	O-Ring
45	3256-22	2	Washer-Flat

☆ Not serviced

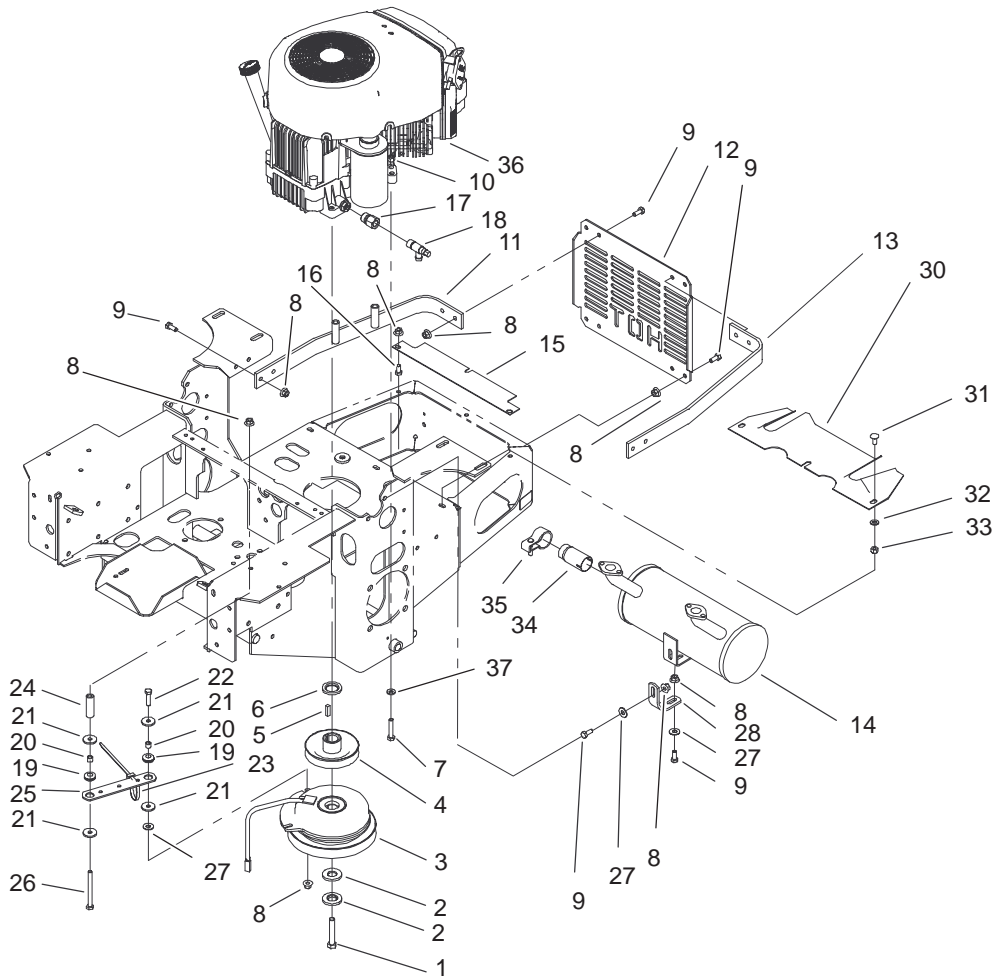

Sheet No.: 10

Engine and Clutch Assembly

Ref. No.	Part No.	Qty.	Description
1	3212-12	1	Screw-Cap, HH
2	1-603610	2	Washer-Spring
3	1-653048	1	Clutch-Stop
4	1-653035	1	Sheave W/Hub
5	1-807259	1	Key
6	103-2308	1	Spacer-Crankshaft
7	322-9	4	Screw-HH
8	32128-20	19	Nut-HF
9	322-3	14	Screw-HH
10	3296-29	4	Nut-Lock, NI
11	1-652146-03	1	Strap-Guard, Engine
12	1-653095-03	1	Shield-Engine
13	1-653093-03	1	Strap-Guard, Engine
14	103-1322	1	Muffler
15	103-1366-03	1	Deflector, Lower Frame
16	322-2	3	Screw-HH
17	103-1966	1	Adapter
18	103-1965	1	Valve-Drain, Oil
19	1-633630	2	Grommet-Brake
20	1-633545	2	Spacer-Grommet
21	1-613235	4	Washer
22	322-6	1	Screw-HH
23	1-303335	2	Tie-Plastic
24	1-523406	1	Bushing-Mount, Seat
25	1-633543-03	1	Strap-Clutch, Brake
26	322-22	1	Screw-HH

Ref. No.	Part No.	Qty.	Description
27	3256-3	3	Washer-Flat
28	1-653196	1	Bracket-Support, Muffler
30	1-653539-03	1	Shield, Heat
31	3230-1	3	Screw-CARR
32	3256-23	3	Washer-Flat
33	3296-29	3	Nut-Lock, NI
34	103-1513	1	Arrester-Spark
35	103-1514	1	Clamp-Muffler
☆36		1	Engine-Kawasaki, Fh680v-Cs10
37	1-303334	2	Washer-Spring

☆ Not serviced

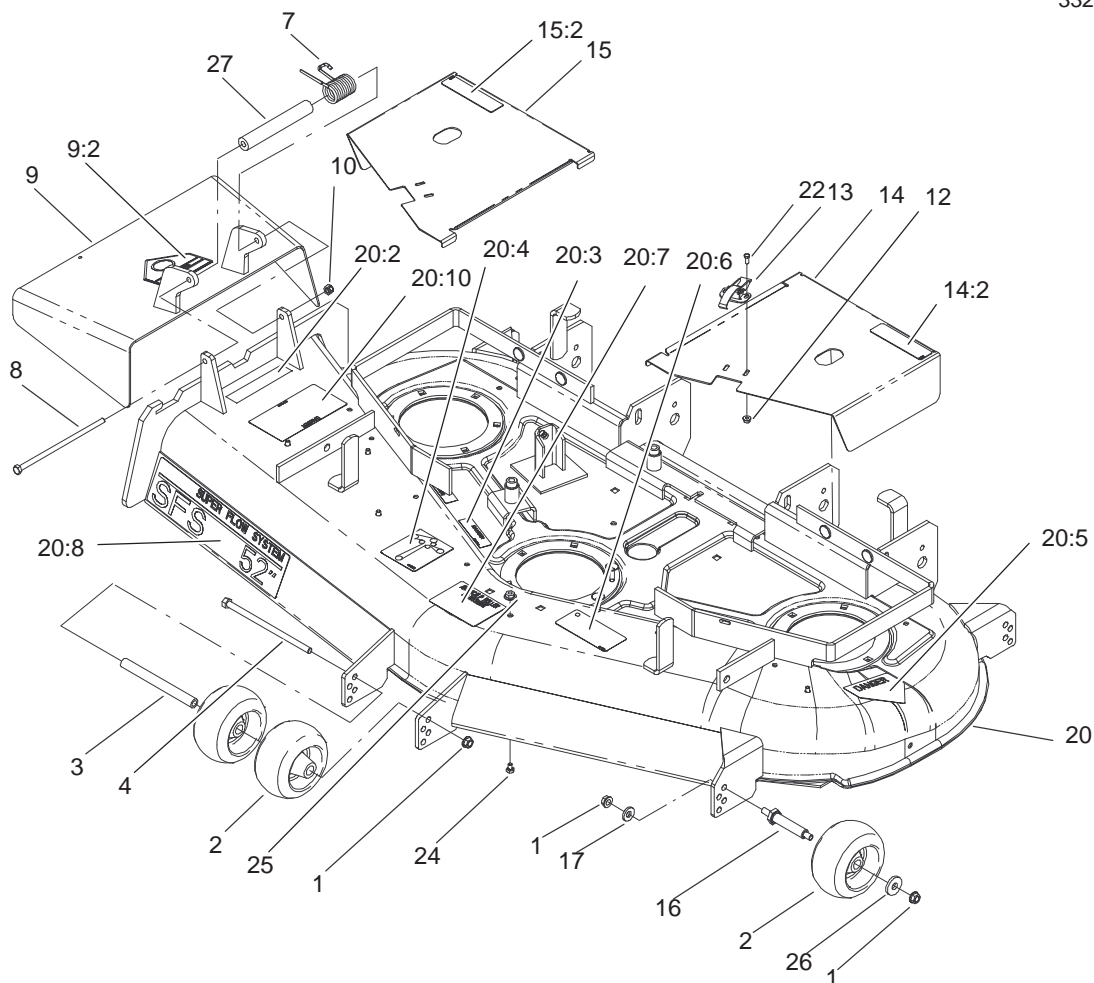

Sheet No.: 14

Deck Assembly

Ref. No.	Part No.	Qty.	Description	Ref. No.	Part No.	Qty.	Description
1	3290-357	9	Nut-HHF	20:8	98-5953	1	Decal-Sfs
2	68-2730	6	Wheel-Gage	20:10	66-1340	1	Decal-Danger
3	98-5967	1	Spacer-Wheel	22	3290-321	4	Screw-HWH
4	323-28	1	Screw-HH	24	321-1	6	Screw-HH
7	104-8554	1	Spring-Torsion	25	32128-33	6	Nut-HF
8	322-50	1	Screw-Cap	26	1-373034	4	Washer-Swivel
9	105-4623	1	Deflector ASM	27	104-8555	1	Spacer-Mounting, Deflector
9:2	54-9220	1	Decal-Danger				
10	3296-29	1	Nut-Lock, NI				
12	32128-17	4	Nut-Lock, Flange				
13	249-21	2	Clamp-Slotted				
14	99-3896	1	LH Cover ASM				
14:2	67-5360	1	Decal-Danger				
15	99-3895	1	RH Cover ASM				
15:2	67-5360	1	Decal-Danger				
16	99-2842	4	Spacer-Wheel				
17	98-5975	4	Washer-Belleville				
20	105-3611	1	Deck ASM W/ Decals				
20:2	104-8569	1	Decal-Warning, Deflector				
20:3	98-5954	3	Decal-Missing, Cover				
20:4	99-3943	1	Decal-Routing, Belt				
20:5	43-8480	1	Decal-Danger				
20:6	93-7818	1	Decal-Torque, Blade Bolt				
20:7	98-3798	1	Decal-Wheel, Gage				

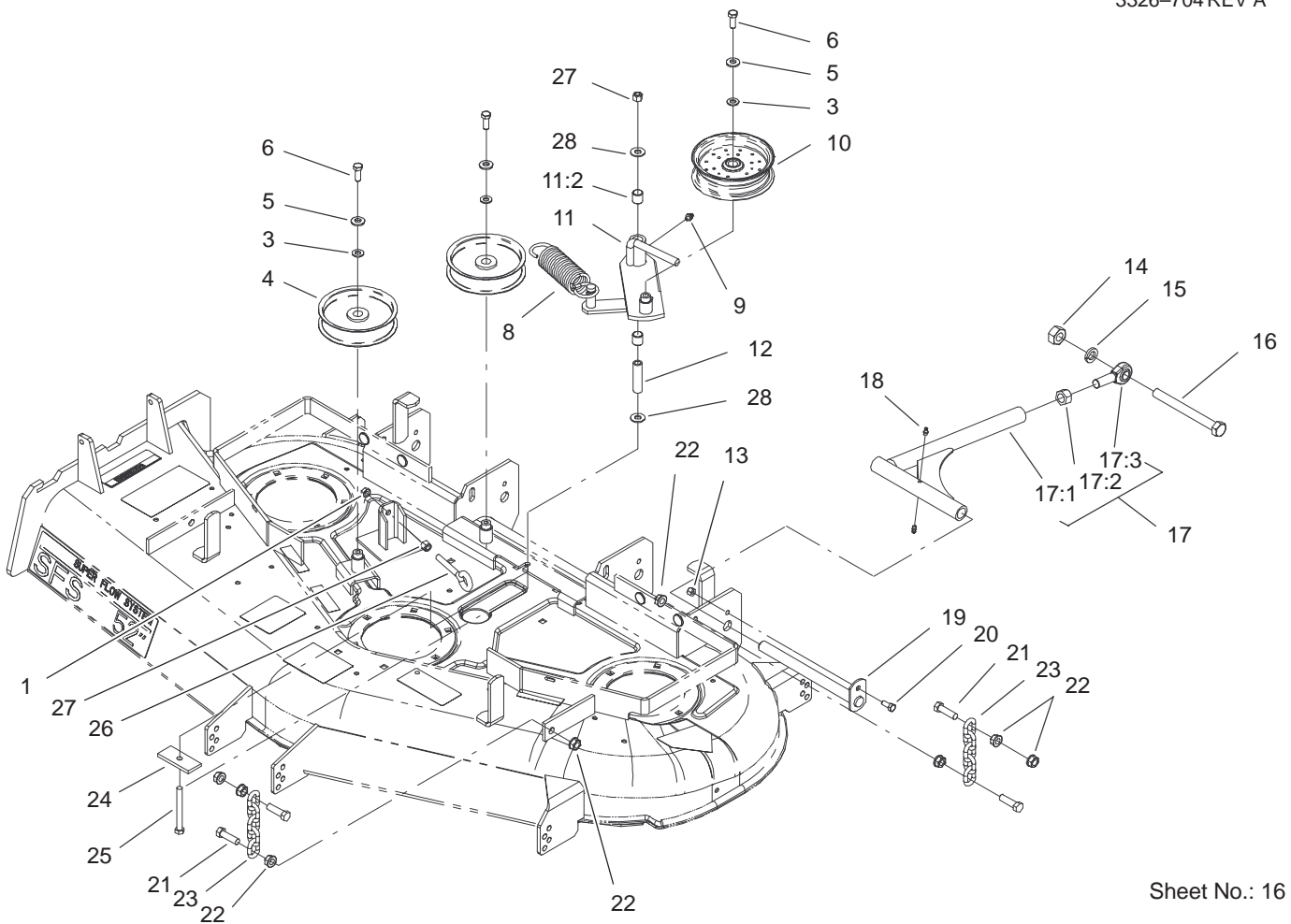

Sheet No.: 16

Idler, Pulley/Lift Strut, Chain Assembly

Ref. No.	Part No.	Qty.	Description
1	3217-7	1	Nut-Hex
3	3256-24	3	Washer-Flat
4	1-613098	2	Pulley-Idler
5	98-5975	3	Washer-Belleville
6	323-6	3	Screw-HH
8	1-633151	1	Spring-Extension
9	302-40	1	Fitting-Grease
10	1-413099	1	Pulley-Idler
11	99-3879	1	Idler Arm ASM
11:2	1-513034	2	Sleeve-Bearing
12	1-603384	1	Bushing-Pivot, Idler
13	3296-29	2	Nut-Lock, NI
14	3217-11	2	Nut-Hex
15	3253-8	2	Washer-Lock
16	1-800344	2	Screw
17	103-1081	2	Strut ASM
17:1	103-1072-01	1	Strut-Deck
17:2	3219-6	1	Nut-Hex
17:3	1-633029	1	Balljoint-Spherical
18	302-19	4	Fitting-Grease
19	1-632199-01	2	Pin-Strut, Deck
20	322-3	2	Screw-HH
21	324-6	8	Screw-HH
22	32128-37	16	Nut-HF
23	1-633447	4	Chain-Lift, Deck
24	99-3946-01	1	Plate-Retainer, Bolt

Ref. No.	Part No.	Qty.	Description
25	1-800805	1	Screw-HH
26	94-2547	1	Bolt-Eye
27	3296-39	2	Nut-Lock, NI
28	1-809107	2	Washer-Hardened

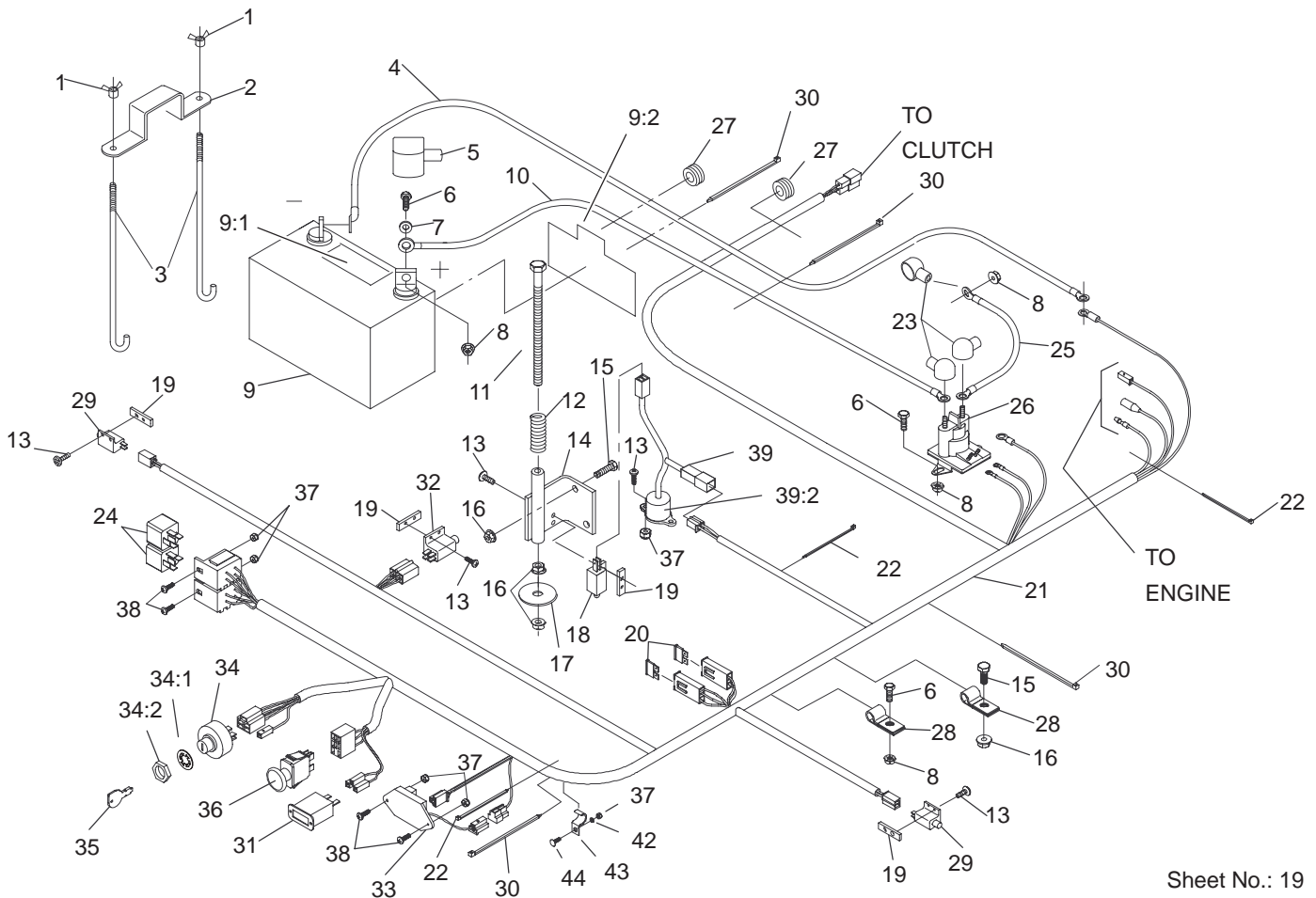

Sheet No.: 19

Electrical System Assembly

Ref. No.	Part No.	Qty.	Description
1	1-543792	2	Wingnut
2	1-633652-03	1	Strap-Holddown, Battery
3	1-633651	2	Bolt-Holddown
4	103-0705	1	Cable-Ground, Negative
5	1-543391	1	Insulator-Battery
6	321-4	5	Screw-HH
7	3256-2	2	Washer-Flat
8	32128-33	6	Nut-HF
9	105-1692	1	Battery - 230 Cca
9:1	104-4163	1	Decal-Battery
9:2	104-4164	1	Decal-Battery
10	103-0707	1	Cable-Battery, Pos.
11	1-800282	1	Screw-HH
12	1-523415	1	Spring-Switch, Seat
13	3290-500	10	Screw-PPH
14	1-652072-03	1	Bracket-Switch, Seat
15	322-3	3	Screw-HH
16	32128-20	5	Nut-HF
17	1-653036	1	Washer
18	1-513152	1	Switch-Closed, Normally
19	1-633181	4	Plate-Tapped
20	1-816001	2	Fuse-Type, Blade
21	103-0623	1	Harness-Wire

Ref. No.	Part No.	Qty.	Description
22	1-303287	3	Tie-Plastic
23	1-543393	3	Insulator-Solenoid
24	1-643275	2	Relay
25	1-633306	1	Wire-Starter
26	1-513075	1	Switch-Solenoid
27	1-543286	2	Grommet
28	1-633396	2	Clip-Loom
29	1-513051	2	Switch-Open, Normally
30	1-303335	4	Tie-Plastic
31	1-513374	1	Meter-Hour
32	1-633111	1	Switch
33	100-6186	1	Module-Delay, Seat
34	88-9830	1	Key Switch ASM
34:1	3254-5	1	Washer-Lock, Internal
34:2	218-461	1	Nut-HH
35	63-8360	2	Key-Ignition
36	1-633673	1	Switch-Delta
37	3296-2	7	Nut-Lock
38	1-807513	4	Bolt-CARR
39	1-644427	1	Tilt Switch ASM
39:2	1-643401	1	Decal-Switch, Mercury
42	3256-14	1	Washer-Flat
43	103-1193	1	Clip-Half, Loom
44	1-807533	1	Bolt-CARR

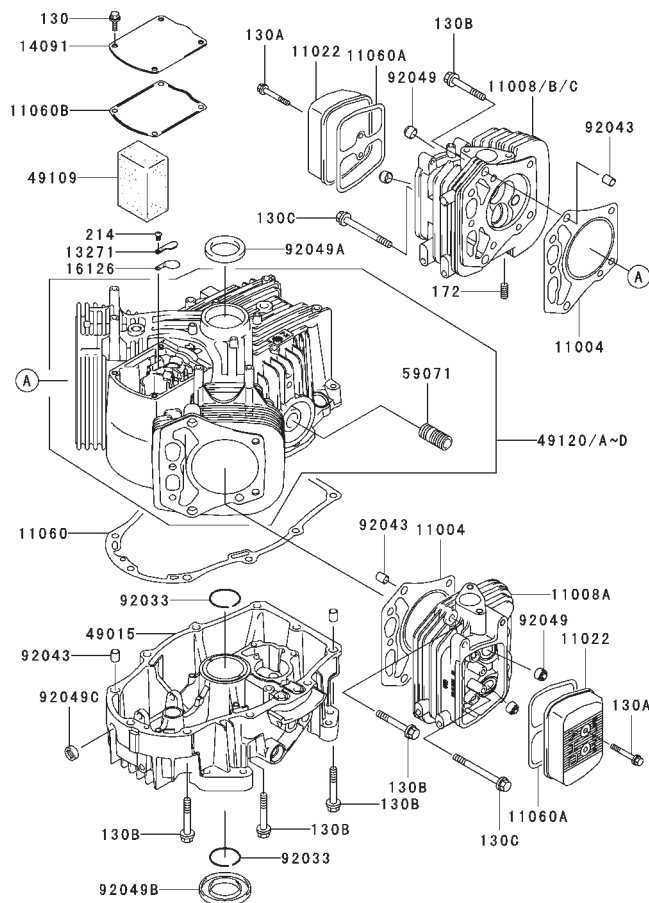

Cylinder/Crankcase Assembly Kawasaki FH680V-CS10

Ref. No.	Part No.	Qty.	Description	Ref. No.	Part No.	Qty.	Description
11004	11004-7004	2	Gasket-Head	130C	130T0875	2	Bolt-Flanged
11008B	11008-7007	1	Head-Comp-Cylinder No. 1	172	172G0818	4	Bolt-Stud
11008A	11008-7004	1	Head-Comp-Cylinder No. 2	214	214B0408	1	Screw-Pan
11022	11022-7002	2	Case-Rocker				
11060	11060-7012	1	Gasket, CrankCase Cover				
11060A	11060-7013	2	Gasket, Rocker Case				
11060B	11060-7014	1	Gasket, Breather				
13271	13271-7006	1	Plate				
14091	14091-7004	1	Cover				
16126	16126-7001	1	Valve				
49015	49015-6225	1	Cover-Crankcase				
49109	49109-7003	1	Element-Breather				
49120C	49120-6122	1	Crankcase-Comp				
59071	59071-2079	1	Joint				
92033	92033-7004	2	Ring-Snap				
92043	92043-7001	6	Pin				
92049	92049-7001	4	Seal-Oil				
92049A	92049-7002	1	Seal-Oil				
92049B	92049-7004	1	Seal-Oil				
92049C	92049-7005	1	Seal-Oil				
130	130B0612	4	Bolt-Flanged				
130A	130B0640	4	Bolt-Flanged				
130B	130T0850	18	Bolt-Flanged				

Obtain Parts from Kawasaki

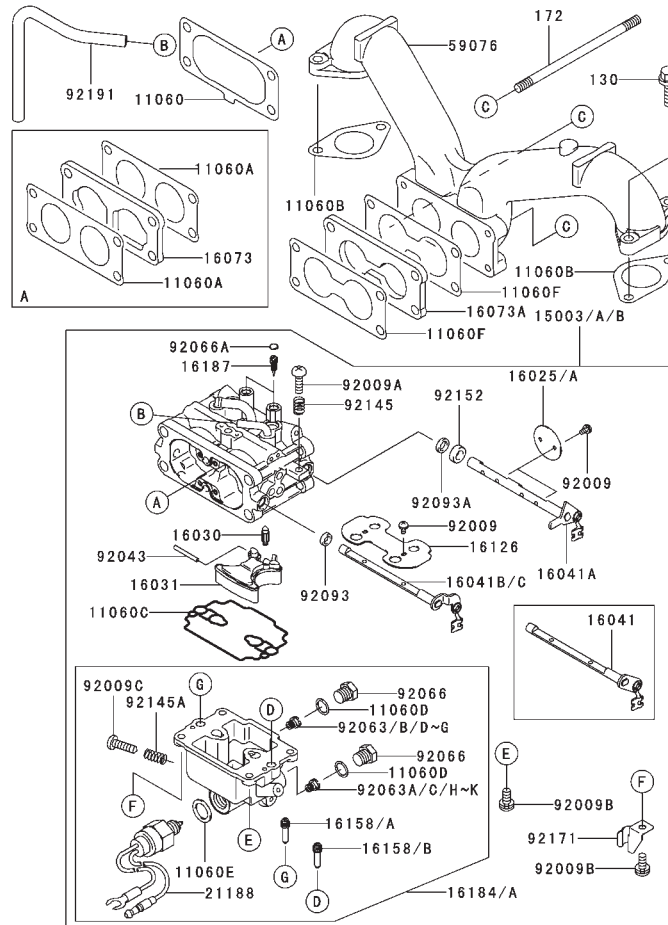

Carburetor Assembly Kawasaki FH680V-CS10

Ref. No.	Part No.	Qty.	Description
11060	11060-7009	1	Gasket, Air Filter
11060B	11060-7011	2	Gasket
11060C	11060-7018	1	Gasket, Float Chamber
11060D	11060-7019	2	Gasket, Main Plug
11060E	11060-7020	1	Gasket, Solenoid
11060F	11060-7024	2	Gasket-Carburetor
15003B	15003-7045	1	Carburetor-Assy
16025A	16025-7003	2	Valve-Throttle
16030	16030-7002	1	Valve-Float
16031	16031-7001	1	Float
16041B	16041-7007	1	Shaft-Carburetor, Choke
16041A	16041-7004	1	Shaft-Carburetor Throttle
16073A	16073-7005	1	Insulator
16126	16126-7004	1	Valve, Choke
16158A	16158-7006	2	Jet-Slow, #56
16158B	16158-7007	2	Jet-Slow, #56
16184A	16184-7006	1	Chamber-Assy-Float
16187	16187-7002	2	Needle-Jet
21188	21188-7001	1	Solenoid
59076	59076-7002	1	Manifold-Intake
92009	92009-7003	6	Screw
92009A	92009-7004	1	Screw
92009B	92009-7005	4	Screw
92009C	92009-7006	1	Screw, Drain

Ref. No.	Part No.	Qty.	Description
92043	92043-7004	1	Pin-Float
92063B	92063-7010	1	Jet-Main
92063C	92063-7011	1	Jet-Main
92063D	92063-7017	AR	Jet-Main, #133
92063F	92063-7018	1	Jet-Main, #130
92063H	92063-7019	AR	Jet-Main, #139
92063J	92063-7020	AR	Jet-Main, #134
92066	92066-7008	2	Plug, Main Jet
92066A	92066-7009	2	Plug, Extension
92093	92093-7001	1	Seal
92093A	92093-7002	1	Seal
92145	92145-7010	1	Spring
92145A	92145-7011	1	Spring
92152	92152-7001	1	Collar
92171	92171-7001	1	Clamp
92191	92191-7010	1	Tube
130	130B0620	4	Bolt-Flanged
172	172G0105	2	Bolt-Stud

Obtain Parts from Kawasaki

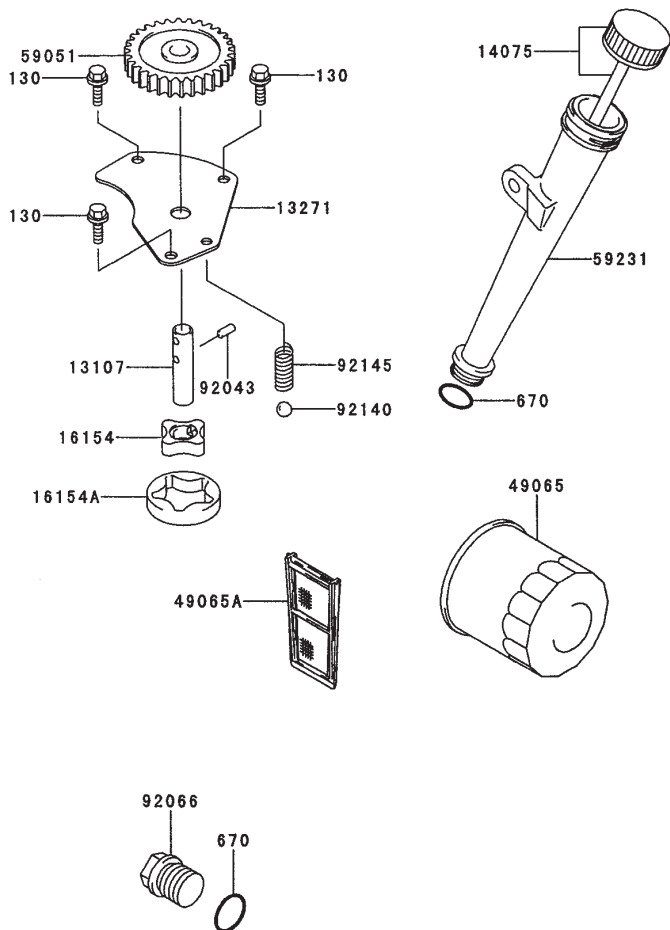

Lubrication-Equipment Assembly Kawasaki FH680V-CS10

Ref. No.	Part No.	Qty.	Description
13107	13107-7009	1	Shaft, Oil Pump
13271	13271-7005	1	Plate
14075	14075-7002	1	Cap-Assy
16154	16154-2053	1	Rotor-Pump, In
16154A	16154-2054	1	Rotor-Pump, Out
49065	49065-2078	1	Filter-Oil
49065A	49065-7003	1	Filter-Oil
59051	59051-7004	1	Gear-Spur
59231	59231-7002	1	Filler
92043	92043-7003	1	Pin
92066	92066-7003	1	Plug
92140	92140-7003	1	Ball
92145	92145-7002	1	Spring
130	130B0612	3	Bolt-Flanged
670	670D2016	3	O-Ring

Ref. No.	Part No.	Qty.	Description

Obtain Parts from Kawasaki

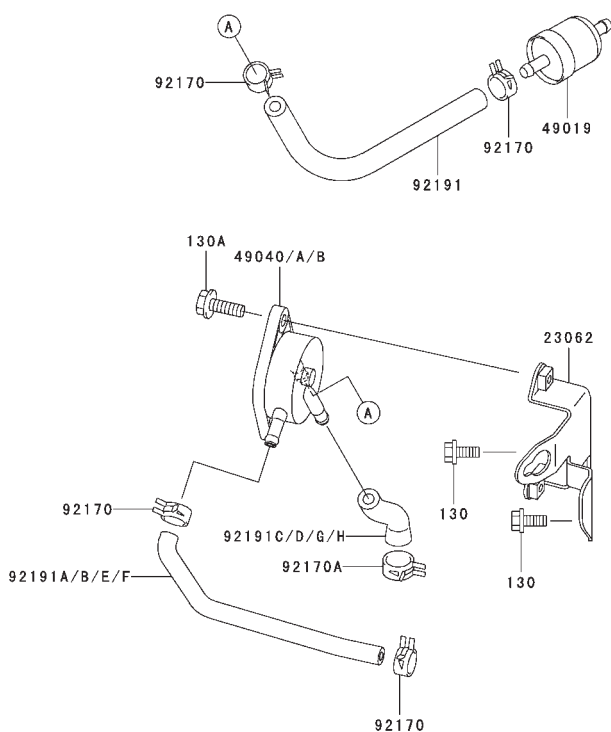

Fuel-Tank/Fuel Valve Assembly Kawasaki FH680V-CS10

Ref. No.	Part No.	Qty.	Description	Ref. No.	Part No.	Qty.	Description
23062	23062-7004-9H	1	Bracket-Comp				
49019	49019-7001	1	Filter-Fuel				
49040B	49040-2075	1	Pump-Fuel				
92170	92170-2088	4	Clamp				
92170A	92170-7003	1	Clamp				
92191	92191-7003	1	Tube				
92191B	92191-7005	1	Tube				
92191E	92191-7017	1	Tube				
92191G	92191-7019	1	Tube				
130	130B0616	2	Bolt-Flanged				
130A	130B0620	2	Bolt-Flanged				

Obtain Parts from Kawasaki

