



## **Mid-Size Mower**

### **ProLine T-Bar Gear 15hp with 44 in. Side Discharge Mower**

**Model No. 30318—Serial No. 230000001 and Up**

**Operator's Manual**



## Warning



### CALIFORNIA

#### Proposition 65 Warning

**The engine exhaust from this product contains chemicals known to the State of California to cause cancer, birth defects, or other reproductive harm.**

**Important** This engine is not equipped with a spark arrester muffler. It is a violation of California Public Resource Code Section 4442 to use or operate this engine on any forest-covered, brush-covered or grass-covered land. Other states or federal areas may have similar laws.

This spark ignition system complies with Canadian ICES-002.

Ce système d'allumage par étincelle de véhicule est conforme à la norme NMB-002 du Canada.

**The enclosed Engine Owner's Manual is supplied for information regarding The U.S. Environmental Protection Agency (EPA) and the California Emission Control Regulation of emission systems, maintenance and warranty.**

**Keep this engine Owner's Manual with your unit. Should this engine Owner's Manual become damaged or illegible, replace immediately. Replacements may be ordered through the engine manufacturer.**

# Contents

	Page
Introduction .....	3
Safety .....	3
Safe Operating Practices .....	3
Toro Mower Safety .....	4
Slope Chart .....	7
Safety and Instruction Decals .....	9
Gasoline and Oil .....	12
Recommended Gasoline .....	12
Using Stabilizer/Conditioner .....	12
Filling the Fuel Tank .....	12
Check Engine Oil Level .....	12
Set Up .....	13
Loose Parts .....	13
Installing the Handle Assembly .....	14
Installing the Shift Lever Plate and Fuel Tank ...	14
Adjusting the Shift Lever Plate .....	15
Installing the Control Rods .....	16

	Page
Installing the Hairpin Cotter Pins and Washers ...	17
Operation .....	18
Think Safety First .....	18
Controls .....	18
Using the Parking Brake .....	19
Starting and Stopping the Engine .....	19
Operating the Mower Blade Control (PTO) .....	19
The Safety Interlock System .....	20
Driving Forward or Backward .....	20
Using the Lower Control Bar Operation .....	21
Stopping the Machine .....	21
Transporting Machines .....	22
Side Discharge or Mulch Grass .....	22
Adjusting the Height-of-Cut .....	22
Adjusting the Gage Wheels .....	22
Adjusting the Handle Height .....	23
Using the Mid-Size Weight Kit .....	23
Maintenance .....	24
Recommended Maintenance Schedule .....	24
Servicing the Air Cleaner .....	25
Servicing the Engine Oil .....	26
Servicing the Spark Plug .....	27
Greasing and Lubrication .....	28
Cleaning the Cooling System .....	29
Checking the Tire Pressure .....	29
Servicing the Fuse .....	29
Servicing the Brakes .....	29
Adjusting the Electric Clutch .....	30
Servicing the Fuel Tank .....	31
Servicing the Fuel Filter .....	31
Servicing the Cutting Blades .....	32
Correcting the Mower Quality of Cut .....	33
Frame Set Up .....	34
Checking the Deck Front-to-Rear Pitch .....	35
Changing the Deck Front-to-Rear Pitch .....	35
Checking the Deck Side-to-Side Leveling .....	36
Changing the Side-to-Side Leveling .....	36
Matching Height of Cut .....	36
Replacing the Traction Drive Belt .....	37
Replacing the Transmission Belt .....	37
Replacing the Mower Belt .....	38
Replacing the PTO Drive Belt .....	38
Replacing the Caster Wheel Fork Bushings .....	39
Caster Wheel and Bearings Service .....	40
Replacing the Grass Deflector .....	40
Wiring Diagram .....	41
Cleaning and Storage .....	42
Troubleshooting .....	42
The Toro Total Coverage Guarantee .....	48

# Introduction

Read this manual carefully to learn how to operate and maintain your product properly. The information in this manual can help you and others avoid injury and product damage. Although Toro designs and produces safe products, you are responsible for operating the product properly and safely.

Whenever you need service, genuine Toro parts, or additional information, contact an Authorized Service Dealer or Toro Customer Service and have the model and serial numbers of your product ready. Figure 1 illustrates the location of the model and serial numbers on the product.

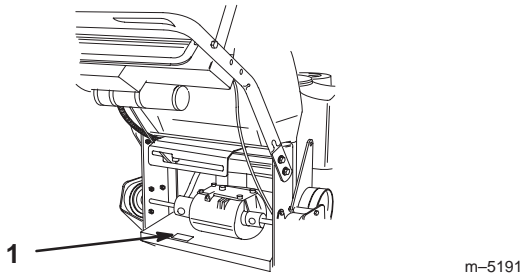

**Figure 1**

1. Location of the model and serial numbers

Write the product model and serial numbers in the space below:

<b>Model No.</b> _____
<b>Serial No.</b> _____

This manual identifies potential hazards and has special safety messages that help you and others avoid personal injury and even death. **Danger**, **Warning**, and **Caution** are signal words used to identify the level of hazard. However, regardless of the hazard, be extremely careful.

**Danger** signals an extreme hazard that *will* cause serious injury or death if you do not follow the recommended precautions.

**Warning** signals a hazard that *may* cause serious injury or death if you do not follow the recommended precautions.

**Caution** signals a hazard that may cause minor or moderate injury if you do not follow the recommended precautions.

This manual uses two other words to highlight information.

**Important** calls attention to special mechanical information and **Note:** emphasizes general information worthy of special attention.

# Safety

**Note:** The addition of attachments made by other manufacturers that do not meet American National Standards Institute certification will cause noncompliance of this machine.

**Improper use or maintenance by the operator or owner can result in injury. To reduce the potential for injury, comply with these safety instructions and always pay attention to the safety alert  symbol, which means CAUTION, WARNING, or DANGER—“personal safety instruction.” Failure to comply with the instruction may result in personal injury or death.**

## Safe Operating Practices

The following instructions are from ANSI standard B71.4—1999.

### Training

- Read the Operator’s Manual and other training material. If the operator(s) or mechanic(s) can not read English it is the owner’s responsibility to explain this material to them.
- Become familiar with the safe operation of the equipment, operator controls, and safety signs.
- All operators and mechanics should be trained. The owner is responsible for training the users.
- Never let children or untrained people operate or service the equipment. Local regulations may restrict the age of the operator.
- The owner/user can prevent and is responsible for accidents or injuries occurring to himself or herself, other people or property.

### Preparation

- Evaluate the terrain to determine what accessories and attachments are needed to properly and safely perform the job. Only use accessories and attachments approved by the manufacturer.
- Wear appropriate clothing including hard hat, safety glasses and hearing protection. Long hair, loose clothing or jewelry may get tangled in moving parts.
- Inspect the area where the equipment is to be used and remove all objects such as rocks, toys and wire which can be thrown by the machine.
- Use extra care when handling gasoline and other fuels. They are flammable and vapors are explosive.
  - Use only an approved container

- Never remove gas cap or add fuel with engine running. Allow engine to cool before refueling. Do not smoke.
- Never refuel or drain the machine indoors.
- Check that operator's presence controls, safety switches and shields are attached and functioning properly. Do not operate unless they are functioning properly.

## Operation

- Never run an engine in an enclosed area.
- Only operate in good light, keeping away from holes and hidden hazards.
- Be sure all drives are in neutral and parking brake is engaged before starting engine. Only start engine from the operator's position.
- Be sure of your footing while using this machine, especially when backing up. Walk, don't run. Never operate on wet grass. Reduced footing could cause slipping.
- Slow down and use extra care on hillsides. Be sure to travel side to side on hillsides. Turf conditions can affect the machine's stability. Use caution while operating near drop-offs.
- Slow down and use caution when making turns and when changing directions on slopes.
- Never raise deck with the blades running.
- Never operate with the PTO shield, or other guards not securely in place. Be sure all interlocks are attached, adjusted properly, and functioning properly.
- Never operate with the discharge deflector raised, removed or altered, unless using a grass catcher.
- Do not change the engine governor setting or overspeed the engine.
- Stop on level ground, disengage drives, engage parking brake (if provided), shut off engine before leaving the operator's position for any reason including emptying the catchers or unclogging the chute.
- Stop equipment and inspect blades after striking objects or if an abnormal vibration occurs. Make necessary repairs before resuming operations.
- Keep hands and feet away from the cutting unit.
- Look behind and down before backing up to be sure of a clear path.
- Keep pets and bystanders away.
- Slow down and use caution when making turns and crossing roads and sidewalks. Stop blades if not mowing.

- Be aware of the mower discharge direction and do not point it at anyone.
- Do not operate the mower under the influence of alcohol or drugs.
- Use care when loading or unloading the machine into or from a trailer or truck.
- Use care when approaching blind corners, shrubs, trees, or other objects that may obscure vision.

## Maintenance and storage

- Disengage drives, set parking brake, stop engine and remove key or disconnect spark plug wire. Wait for all movement to stop before adjusting, cleaning or repairing.
- Clean grass and debris from cutting unit, drives, mufflers, and engine to help prevent fires. Clean up oil or fuel spillage.
- Let engine cool before storing and do not store near flame.
- Shut off fuel while storing or transporting. Do not store fuel near flames or drain indoors.
- Park machine on level ground. Set parking brake. Never allow untrained personnel to service machine.
- Use jack stands to support components when required.
- Carefully release pressure from components with stored energy.
- Remove spark plug wire before making any repairs.
- Use care when checking blades. Wrap the blade(s) or wear gloves, and use caution when servicing them. Only replace blades. Never straighten or weld them.
- Keep hands and feet away from moving parts. If possible, do not make adjustments with the engine running.
- Keep all parts in good working condition and all hardware tightened. Replace all worn or damaged decals.

## Toro Mower Safety

The following list contains safety information specific to Toro products and other safety information you must know.

This product is capable of amputating hands and feet and throwing objects. Always follow all safety instructions to avoid serious injury or death.

This product is designed for cutting and recycling grass or, when equipped with a grass bagger, for catching cut grass. Any use for purposes other than these could prove dangerous to user and bystanders.

## General Operation

- Allow only responsible adults who are familiar with the instructions to operate the machine.
- Be sure the area is clear of other people before mowing. Stop the machine if anyone enters the area.
- Do not mow in reverse unless absolutely necessary. Always look down and behind before and while backing.
- Be aware of the mower discharge direction and do not point it at anyone. Do not operate the mower without either the entire grass catcher or the guard in place.
- Slow down before turning. Sharp turns on any terrain may cause loss of control.
- Turn off blades when not mowing.
- Keep hands, feet, hair and loose clothing away from attachment discharge area, underside of mower and any moving parts while engine is running.
- Stop the engine before removing the grass catcher or unclogging the chute.
- Mow only in daylight or good artificial light.
- Watch for traffic when operating near or crossing roadways.
- Do not touch equipment or attachment parts which may be hot from operation. Allow to cool before attempting to maintain, adjust or service.
- Use only Toro-approved attachments. Warranty may be voided if used with unapproved attachments.

## Slope Operation

Slopes and ramps are a major factor related to loss-of-control and accidents, which can result in severe injury or death. All slopes and ramps require extra caution. If you feel uneasy on a slope, do not mow it.

### DO

- Remove obstacles such as rocks, tree limbs, etc. from the mowing area. Watch for holes, ruts or bumps. Tall grass can hide obstacles.
- Watch for holes, ruts or bumps. Tall grass can hide obstacles.
- Use slow speed so that you will not have to stop while on the slope.
- Use extra care with grass catchers or other attachments. These can change the stability of the machine.
- Keep all movement on slopes slow and gradual. Do not make sudden changes in speed or direction.
- Avoid starting or stopping on a slope. If tires lose traction, disengage the blades.

- Check carefully for overhead clearances (i.e. branches, doorways, electrical wires) before driving under any objects and do not contact them.
- Mow slopes side to side.

### DO NOT

- Do not mow slopes greater than 15 degrees.
- Avoid turning on slopes. If you must turn, turn slowly and gradually downhill, if possible.
- Do not mow near drop-offs, ditches, or embankments. The machine could suddenly turn over if a wheel goes over the edge of a cliff or ditch, or if an edge caves in.
- Do not mow on wet grass. Reduced traction could cause sliding.
- Do not use a grass catcher on steep slopes. Heavy grass bags could cause loss of control of the machine.
- Do not mow up and down slopes.

## Service

- Never store the machine or fuel container inside where there is an open flame, such as near a water heater or furnace.
- Keep nuts and bolts tight, especially the blade attachment bolts. Keep equipment in good condition.
- Never tamper with safety devices. Check safety systems for proper operation before each use.
- Use only genuine replacement parts to ensure that original standards are maintained.
- Check brake operation frequently. Adjust and service as required.



# Slope Chart

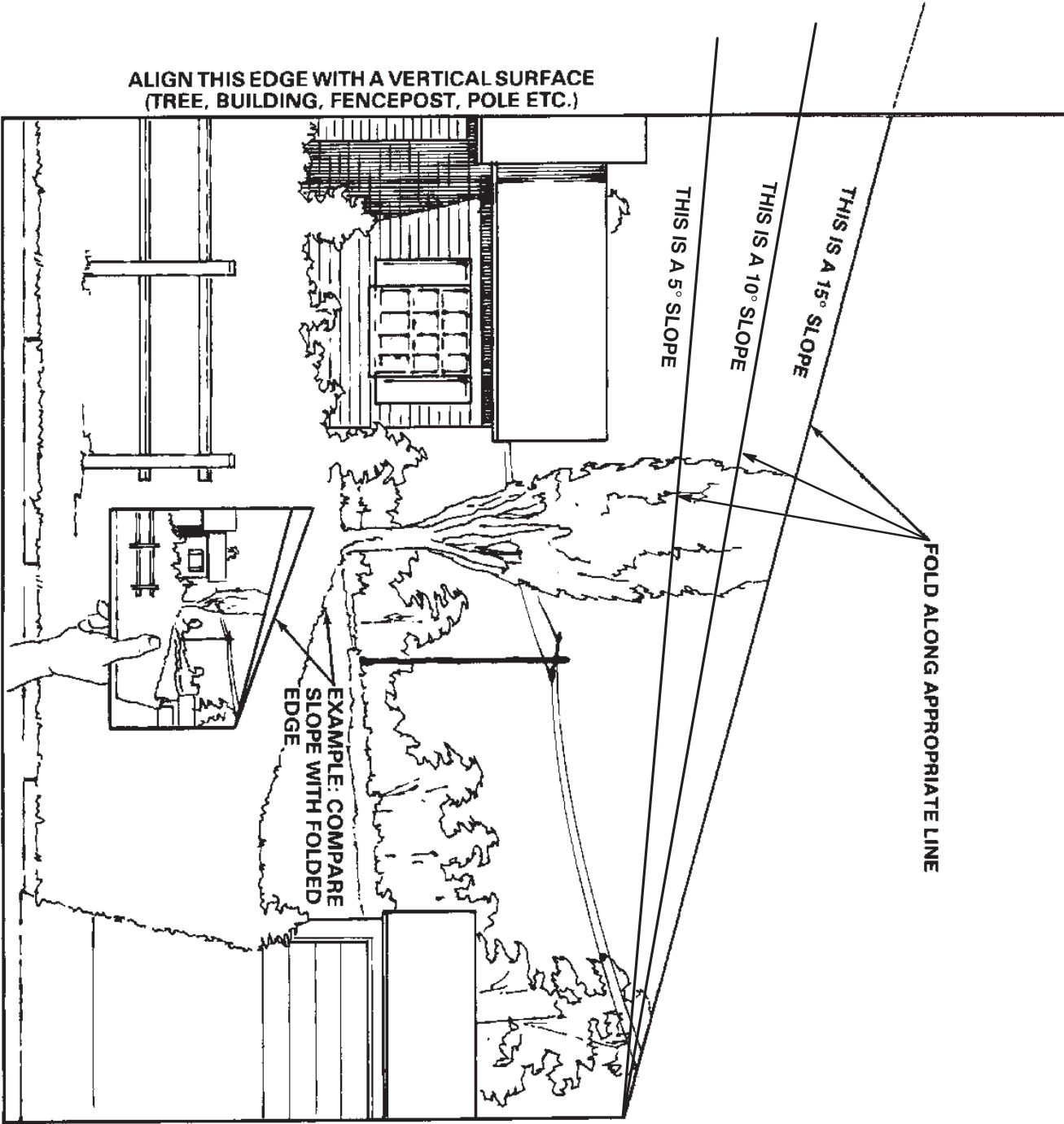



# Safety and Instruction Decals



Safety decals and instructions are easily visible to the operator and are located near any area of potential danger. Replace any decal that is damaged or lost.



43-8480

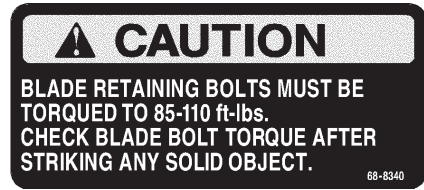

68-8340



82-2280



52-2010



82-2290



93-1122



66-1340



95-2814



67-5360



98-0776

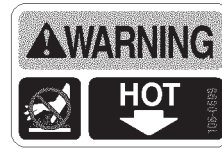

106-0699



98-4387

1. Warning—wear hearing protection.

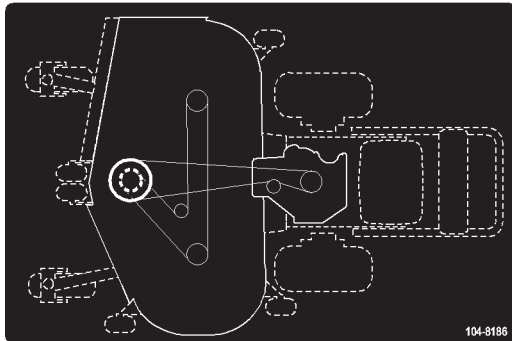

104-8186

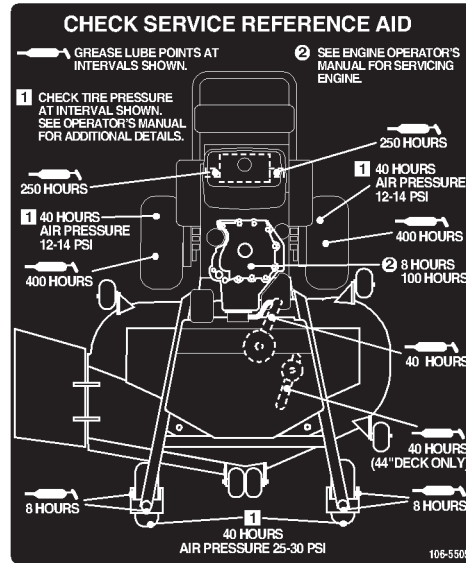

106-5505



104-8569

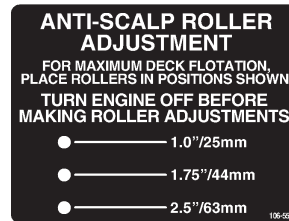

106-5532



105-0884

**HEIGHT OF CUT PINS ADJUSTMENT**

- POSITION ALL PINS IN SAME HEIGHT OF CUT HOLE
- TURN ENGINE OFF BEFORE ADJUSTING DECK CUTTING HEIGHT
- NOTE: HEIGHT IS BASED ON USING ONE FRONT SPACER AND ONE REAR SPACER ON ADJUSTMENT PINS
- ADD ONE ADDITIONAL SPACER TO INCREASE CUTTING HEIGHT 1/4 INCH
- NOTE: REFER TO OPERATOR'S MANUAL FOR ADDITIONAL HEIGHT OF CUT ADJUSTMENT.

106-0635

106-0635

USE REVERSE - TRACTION DRIVE BAR ONLY. DO NOT SHIFT UNDER LOAD. USE FORWARD - TRACTION DRIVE BAR ONLY

**R N 1 2 3 4 5**

106-5494

106-5494

CHOKE

FAST

SLOW

ENGINE SPEED

IGNITION

BLADE ENGAGEMENT

106-5499

PROLINE

TORO

106-5499

1. Engine—stop
2. Engine—start
3. Move the control bar to the handle, then pull the knob.

# Gasoline and Oil

## Recommended Gasoline

Use UNLEADED Regular Gasoline suitable for automotive use (85 pump octane minimum). Leaded regular gasoline may be used if unleaded regular is not available.

**Important** Never use methanol, gasoline containing methanol, or gasohol containing more than 10% ethanol because the fuel system could be damaged. Do not mix oil with gasoline.



### Danger



In certain conditions, gasoline is extremely flammable and highly explosive. A fire or explosion from gasoline can burn you and others and can damage property.

- Fill the fuel tank outdoors, in an open area, when the engine is cold. Wipe up any gasoline that spills.
- Never fill the fuel tank inside an enclosed trailer.
- Do not fill the fuel tank completely full. Add gasoline to the fuel tank until the level is 1/4 to 1/2 in. (6 to 13 mm) below the bottom of the filler neck. This empty space in the tank allows gasoline to expand.
- Never smoke when handling gasoline, and stay away from an open flame or where gasoline fumes may be ignited by a spark.
- Store gasoline in an approved container and keep it out of the reach of children. Never buy more than a 30-day supply of gasoline.
- Always place gasoline containers on the ground away from your vehicle before filling.
- Do not fill gasoline containers inside a vehicle or on a truck or trailer bed because interior carpets or plastic truck bed liners may insulate the container and slow the loss of any static charge.
- When practical, remove gas-powered equipment from the truck or trailer and refuel the equipment with its wheels on the ground.
- If this is not possible, then refuel such equipment on a truck or trailer from a portable container, rather than from a gasoline dispenser nozzle.
- If a gasoline dispenser nozzle must be used, keep the nozzle in contact with the rim of the fuel tank or container opening at all times until fueling is complete.



### Warning



Gasoline is harmful or fatal if swallowed. Long-term exposure to vapors can cause serious injury and illness.

- Avoid prolonged breathing of vapors.
- Keep face away from nozzle and gas tank or conditioner opening.
- Keep gas away from eyes and skin.

## Using Stabilizer/Conditioner

Use a fuel stabilizer/conditioner in the machine to provide the following benefits:

- Keeps gasoline fresh during storage of 90 days or less. For longer storage it is recommended that the fuel tank be drained.
- Cleans the engine while it runs
- Eliminates gum-like varnish buildup in the fuel system, which causes hard starting

**Important** Do not use fuel additives containing methanol or ethanol.

Add the correct amount of gas stabilizer/conditioner to the gas.

**Note:** A fuel stabilizer/conditioner is most effective when mixed with fresh gasoline. To minimize the chance of varnish deposits in the fuel system, use fuel stabilizer at all times.

## Filling the Fuel Tank

1. Shut the engine off and set the parking brake.
2. Clean around fuel tank cap and remove the cap. Add unleaded regular gasoline to fuel tank, until the level is 1/4 to 1/2 inch (6 to 13 mm) below the bottom of the filler neck. This space in the tank allows gasoline to expand. Do not fill the fuel tank completely full.
3. Install fuel tank cap securely. Wipe up any gasoline that may have spilled.

## Check Engine Oil Level

Before you start the engine and use the machine, check the oil level in the engine crankcase; refer to Checking Oil Level, page 26.

# Set Up

**Note:** Determine the left and right sides of the machine from the normal operating position.

## Loose Parts

**Note:** Use the chart below to verify all parts have been shipped.

Step	Description	Qty.	Use
<b>1</b>	Handle assembly	1	Installing the handle assembly
	Flanged bolt 3/8 x 1 inch	4	
	Flange nut 3/8 inch	4	
<b>2</b>	Fuel tank with studs installed	1	Installing shift lever plate and fuel tank
	Shift lever plate	1	
	Bolt, 5/16 x 7/8 inch	2	
	Lock washer, 5/16 inch	2	
	Washer, 5/16 inch	4	
	Spring	2	
	Hose clamp	1	
<b>3</b>	No parts needed		Adjusting the shift lever plate
<b>4</b>	Clevis pin	2	Installing the control rods
	Washer	2	
	Hairpin cotter pin	2	
<b>5</b>	Hairpin cotter pin	2	Installing the hairpin cotter pins and washers
<b>6</b>	Oil drain hose	1	Use for draining engine oil
<b>7</b>	Operator's Manual	1	Read before operating machine
	Engine Operator's Manual	1	Read before operating machine
	Parts Catalog	1	
	Registration card	1	Fill out and return to Toro

## Step

# 1

### Parts needed for this step:

- 1 Handle assembly
- 4 Flange bolts, 3/8 x 1 inch
- 4 Flange nuts, 3/8 inch

## Installing the Handle Assembly

1. Align handle with upper mounting holes in rear frame (Fig. 2).
2. Secure the handle at each upper mounting hole with a flange bolt (3/8 x 1 inch) and flange nut (Fig. 2).
3. Select the low position for the lower mounting hole (Fig. 2).
4. Secure the handle at each lower mounting hole with a flange bolt (3/8 x 1 inch) and flange nut (Fig. 2).

**Note:** The handle position can be adjusted to match the operator's height preference.

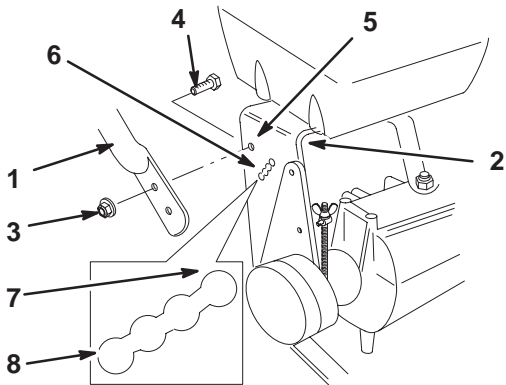

m-6403

**Figure 2**

- |                              |                         |
|------------------------------|-------------------------|
| 1. Upper handle              | 5. Upper mounting hole  |
| 2. Rear frame                | 6. Lower mounting holes |
| 3. Flange nut, 3/8 inch      | 7. Low position         |
| 4. Flange bolt, 3/8 x 1 inch | 8. High position        |

**Note:** Handle assembly must be installed before fuel tank is installed.

## Step

# 2

### Parts needed for this step:

- 1 Fuel tank with studs installed
- 1 Shift lever plate
- 2 Bolts, 5/16 x 7/8 inch
- 2 Lock washers, 5/16 inch
- 2 Flat washers, 5/16 inch
- 2 Springs
- 1 Hose clamp

## Installing the Shift Lever Plate and Fuel Tank

1. Remove the bolts and nuts holding the shift lever plate to the rear frame. Discard these nuts and bolts.
2. Slide the shift lever plate over the shift lever and under the bottom of the rear frame (Fig. 3).

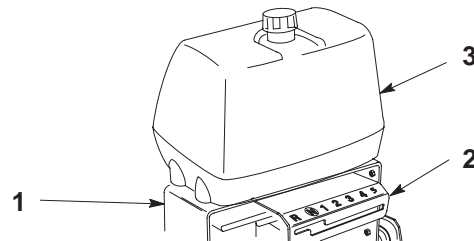

m-5221

**Figure 3**

- |                      |              |
|----------------------|--------------|
| 1. Rear frame        | 3. Fuel tank |
| 2. Shift lever plate |              |
3. Align fuel tank with the top of the rear frame (Fig. 3).
  4. Push the fuel line onto the fuel tank connection and secure it with the hose clamp that is on the fuel line (Fig. 5).

**Note:** To ease assembly of the fuel line to fuel tank connection, apply a light lubricant, such as WD 40, to the end of the fuel line.

**Note:** Make sure the fuel line and clamp are on as shown in Figure 4.

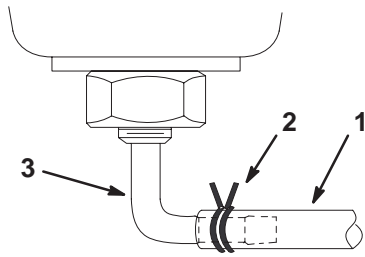

m-6504

**Figure 4**

- |              |                         |
|--------------|-------------------------|
| 1. Fuel line | 3. Fuel tank connection |
| 2. Clamp     |                         |

- Secure the right side of shift lever plate and fuel tank to the rear frame (Fig. 5) with 2 bolts (5/16 x 7/8 inch), lock washers (5/16 inch) and washers (5/16 inch) (Fig. 5).
- Secure the left side shift lever plate and fuel tank to the rear frame (Fig. 5) with washers (5/16 inch), springs and locknuts (5/16 inch) (Fig. 5).

**Note:** Tighten left side of shift lever plate until it is completely tight and then unscrew locknut one full turn. This will allow the spring to work.

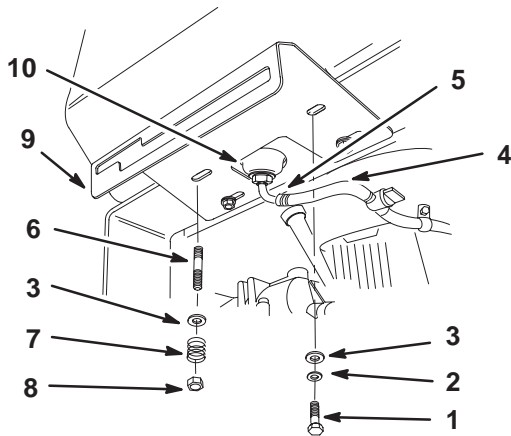

m-6465

**Figure 5**

- |                            |                          |
|----------------------------|--------------------------|
| 1. Bolt, 5/16 x 7/8 inch   | 6. Stud                  |
| 2. Lock washers, 5/16 inch | 7. Spring                |
| 3. Washer, 5/16 inch       | 8. Locknut               |
| 4. Fuel line               | 9. Shift lever plate     |
| 5. Hose clamp              | 10. Fuel tank connection |

Step

# 3

**No parts needed for this step.**

## Adjusting the Shift Lever Plate

- Shift lever to second gear and check alignment of lever in slot of shifter lever plate. The clearance between top and bottom of the shift lever should be equal (Fig. 7).
- If clearance is not correct, remove lever and bend it slightly to adjust (Fig. 6).

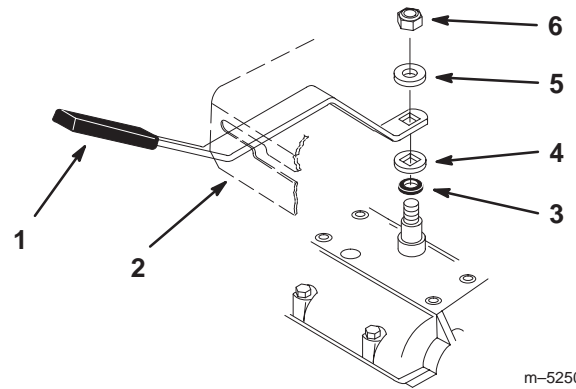

m-5250

**Figure 6**

- |                       |                       |
|-----------------------|-----------------------|
| 1. Shift lever        | 4. Square hole washer |
| 2. Shift lever plate  | 5. Spring washer      |
| 3. Rubber seal washer | 6. Locknut, 3/8 inch  |

**Note:** Do not bend lever while attached to transmission shaft or damage may occur.

- Shift lever to neutral and check alignment of lever in slot of shifter lever plate. The clearance on the sides of shift lever should be equal (Fig. 7).
- If clearance is not correct, loosen shift lever plate and adjust it side-to-side. Tighten the shift lever plate.

**Note:** Tighten the left side of the shift lever plate until it is completely tight and then unscrew the locknut one full turn. This will allow the spring to work.

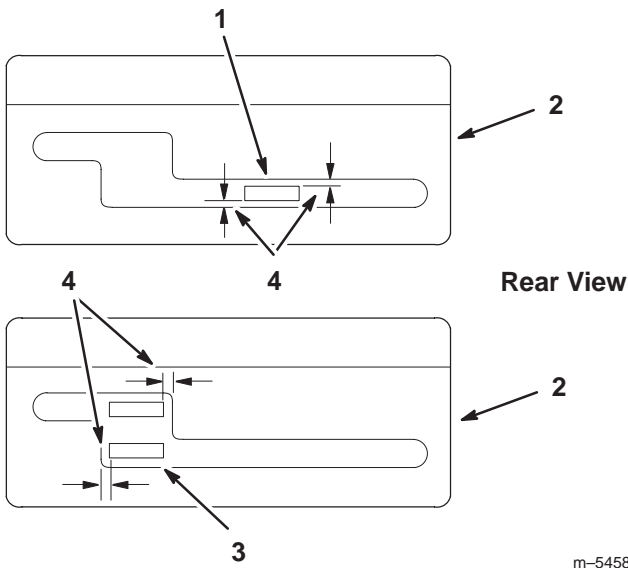

**Figure 7**

- |                          |                         |
|--------------------------|-------------------------|
| 1. Shift lever, 2nd gear | 3. Shift lever, neutral |
| 2. Shift lever plate     | 4. Equal distance       |



**Parts needed for this step:**

- 2 Clevis pins
- 2 Washers
- 2 Hairpin cotter pins

**Installing the Control Rods**

1. Make sure the rod fittings are equal distance onto each control rod. The rod fittings should be approximately 3-1/2 inch (89 mm) from the start of the threads (Fig. 8).
2. Slide clevis pins through rod fittings and mounting holes in idler brackets (from outside) (Fig. 8). Secure with washers and hairpin cotters (Fig. 8).

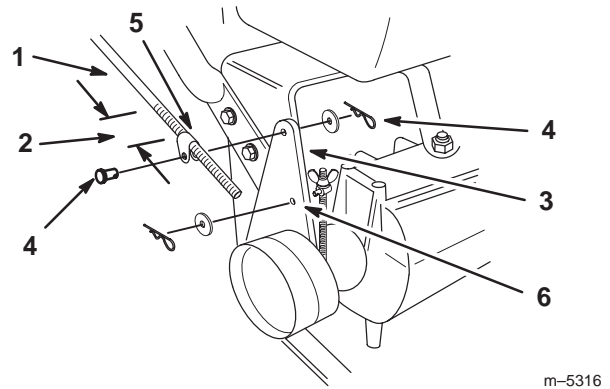

**Figure 8**

- |                            |  |
|----------------------------|--|
| 1. Control rod and fitting | 4. Clevis pin, washer and hairpin cotter |
| 2. 3-1/2inch (89 mm)       | 5. Rod fitting                           |
| 3. Idler bracket           | 6. Hole F                                |

3. Check the gap between upper control bar and fixed bar with wheel drive fully engaged. Gap should be approximately 1 to 1-1/4 inch (25-32 mm) (Fig. 9).

**Note:** The upper control bar and fixed bar must be parallel when in engaged, drive, relaxed and brake positions.

4. Check the operation. If adjustment is required, remove hairpin cotter, washer and clevis pin securing control rod fitting to idler bracket.
5. Thread fitting up or down on rod until proper position is attained and install the fitting into the idler bracket with clevis pin, washer and hairpin cotter.

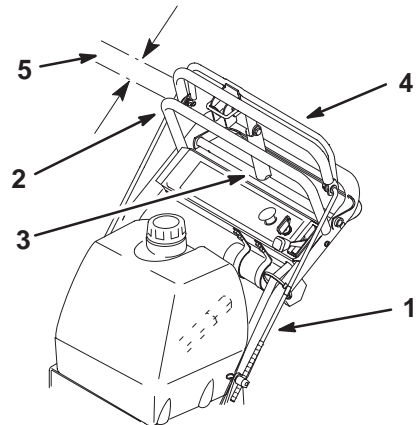
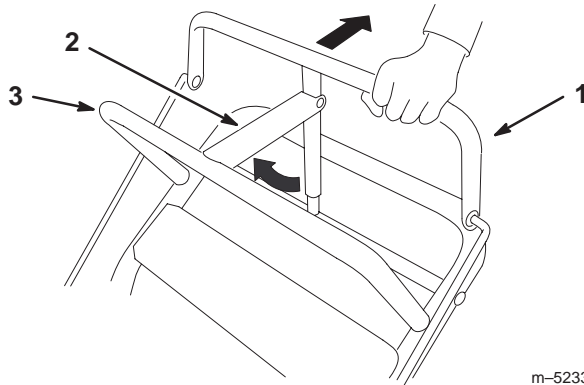

**Figure 9**

- |                        |                                  |
|------------------------|----------------------------------|
| 1. Control rod         | 5. 1 to 1-1/4 inch (25-32mm) gap |
| 2. Fixed control bar   | 6. Fitting                       |
| 3. Parking brake lever |                                  |
| 4. Upper control bar   |                                  |

6. Check the parking brake adjustment (Fig. 10). Refer to Checking the Brakes, page 30.

**Note:** Make sure brake rod is installed in front (F) mounting hole in idler bracket.



m-5233

**Figure 10**

1. Upper control bar
2. Parking brake lever
3. Fixed bar

## Step 5

### Parts needed for this step:

- 2 Hairpin cotter pins

### Installing the Hairpin Cotter Pins and Washers

Unused height-of-cut spacers may be stored on posts and retained by a hairpin cotter.

1. On the opposite side of the muffler, install unused washers and hairpin cotter pins into front and rear height-of-cut pins (Fig. 11).

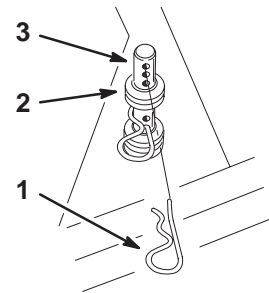

m-6505

**Figure 11**

1. Hairpin cotter
2. Unused spacers
3. Height-of-cut post



## Using the Parking Brake

Stop on level ground, disengage drives, engage parking brake, shut off engine and remove key. Always set the parking brake when you stop the machine or leave it unattended.

### Setting the Parking Brake

1. Pull the upper control bar (Fig. 14) rearward and hold it in this position.
2. Lift the parking brake lock (Fig. 14) up and gradually release the upper control bar. The brake lock should stay in the set (locked) position.

### Releasing the Parking Brake

1. Pull rearward on the upper control bar (Fig. 14). Lower the parking brake lock to the released position.
2. Gradually release the upper control bar.

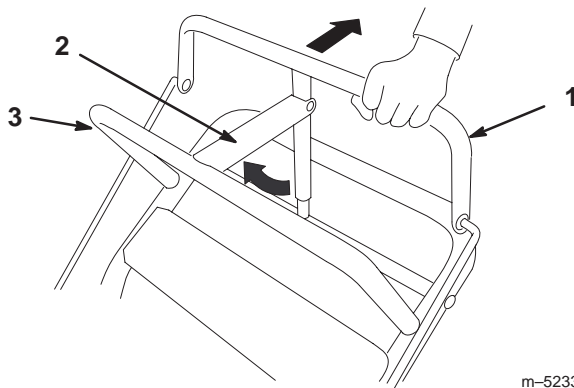

Figure 14

1. Upper control bar
2. Parking brake lever (set position)
3. Fixed bar

## Starting and Stopping the Engine

### Starting the Engine

1. Make sure spark plug wire(s) are installed on spark plug(s) and fuel valve is open.
2. Move the shift lever to neutral, set the parking brake and turn ignition key to run.
3. Move the throttle control to the choke position before starting a cold engine.

**Note:** A warm or hot engine usually does not require any choking. To start a warm engine, move throttle control to the **fast** position.

4. Grasp recoil starter handle firmly and pull out until positive engagement results; then pull handle vigorously to start engine and allow rope to recoil slowly.

**Important** Do not pull recoil rope to its limit or let go of the starter handle when rope is pulled out because rope may break or recoil assembly may be damaged.

### Stopping the Engine

1. Move the throttle lever to **slow** (Fig. 15).
2. Let engine idle for 30 to 60 seconds before turning the ignition key to **off**.
3. Turn the ignition key to **off** (Fig. 15).

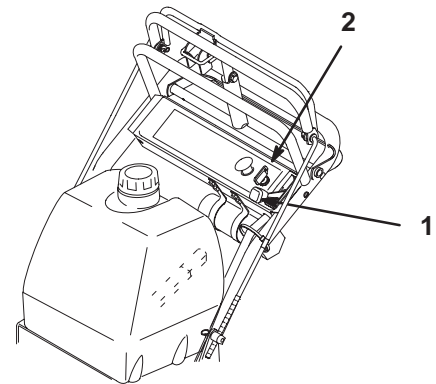

Figure 15

1. Throttle lever
2. Ignition key

4. Set the parking brake and remove key.
5. Pull wire off spark plug(s) to prevent possibility of accidental starting before storing machine.
6. Close fuel shut off valve before storing machine.

**Important** Make sure fuel shut off valve is closed before transporting or storing machine, as fuel leakage may occur.

## Operating the Mower Blade Control (PTO)

The blade control switch (PTO) in conjunction with the blade control bail engages and disengages power to the electric clutch and mower blades.

### Engaging the Mower Blades (PTO)

1. Release the upper control bar to stop the machine (Fig. 16).
2. To engage blade, squeeze blade control bail against upper control bar (Fig. 16).

3. Pull blade switch (PTO) up and release. Hold blade control bail against control bar while operating.
4. Repeat procedure to engage mower blades if blade control bail is released.

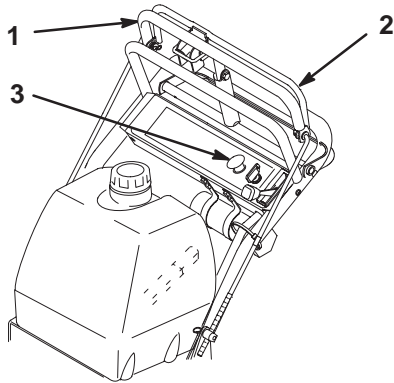

m-6443

**Figure 16**

- |                       |                               |
|-----------------------|-------------------------------|
| 1. Upper control bar  | 3. Blade control switch (PTO) |
| 2. Blade control bail |                               |

## Disengaging the Mower Blades (PTO)

1. Release blade control bail to disengage blades (Fig. 16).

## The Safety Interlock System

⚠
Caution
⚠

**If safety interlock switches are disconnected or damaged the machine could operate unexpectedly causing personal injury.**

- Do not tamper with the interlock switches.**
- Check the operation of the interlock switches daily and replace any damaged switches before operating the machine.**

### Understanding the Safety Interlock System

The safety interlock system is designed to prevent the mower blades from rotating unless:

- The control bail is depressed.
- The blade control switch (PTO) is pulled **on**.

The safety interlock system is designed to stop the mower blades if you release the blade control bail.

### Testing the Safety Interlock System

Test the safety interlock system before you use the machine each time.

**Note:** If the safety system does not operate as described below, have an Authorized Service Dealer repair the safety system immediately.

1. Set the parking brake and start the engine; refer to Starting and Stopping the Engine, page 19.
2. Squeeze the blade control bail against upper control bar. **The blades should not rotate.**
3. Then continue holding the blade control bail and pull up on the blade control switch and release. The clutch should engage and the mower blades begin rotating.
4. Release the blade control bail. **The blades should stop rotating.**
5. With the engine running, pull up the blade control switch (PTO) and release without holding the blade control bail. **The blades should not rotate.**

## Driving Forward or Backward

The throttle control regulates the engine speed as measured in rpm (revolutions per minute). Place the throttle control in the **fast** position for best mowing performance.

### Driving Forward

1. To go forward, move the shift lever to a forward gear (Fig. 17).
2. Release the parking brake; refer to Releasing the Parking Brake, page 19.
3. Slowly press on the upper control bar to move forward (Fig. 17).

To go straight, apply equal pressure to both ends of the upper control bar (Fig. 17).

To turn, release pressure on the upper control bar side in the direction you want to turn (Fig. 17).

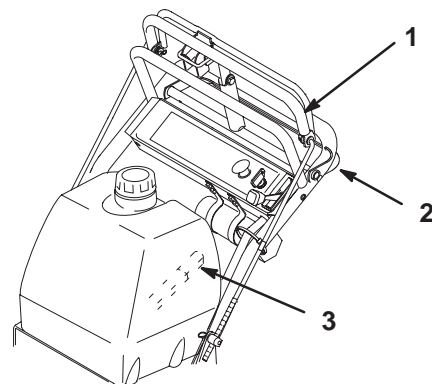

m-6443

**Figure 17**

- |                      |                |
|----------------------|----------------|
| 1. Upper control bar | 3. Shift lever |
| 2. Lower control bar |                |



## Driving Backward

1. To go backward, move the shift lever to reverse gear.
2. Release the parking brake; refer to Releasing the Parking Brake, page 19.
3. Slowly squeeze the lower control bar and handle together to move rearward (Fig. 17).

## Using the Lower Control Bar Operation

This procedure is for driving up a curb. This can be performed while driving forward or backward.

**Note:** Some curbs do not allow the rear drive tires to contact the curb. If this happens, drive the machine up the curb at an angle.

 **Warning** 

A blade can be bent or damaged when driving up a curb. Pieces of blade that may be thrown could seriously injure or kill you or bystanders.

- Do not run blades while driving up a curb forward or backward.

### Driving Forward Up a Curb

1. Disengage the mower blades.
2. Select first gear to drive the machine.
3. Drive machine until the castor wheels contact curb (Fig. 18).
4. Lift the front of the machine by pushing down on the handle (Fig. 18).
5. Drive machine until drive wheels contact curb (Fig. 18).
6. Lower the front of the machine (Fig. 18).

**Note:** Both drive wheels should contact the curb and caster wheels straight.

7. At the same time engage lower control bar and lift up on handle to drive over the curb (Fig. 17 and 18).

**Note:** Lifting up on handle will assist driving the machine up a curb and not spin the drive wheels.

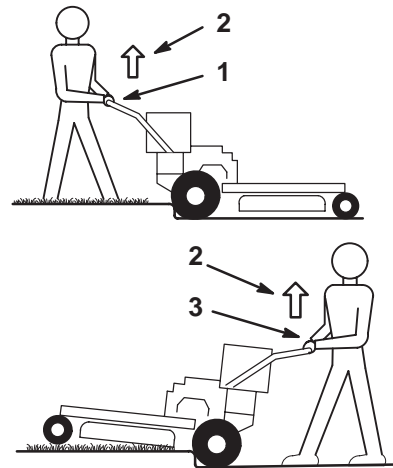

Figure 18

1. Lower Control Bar engaged and mower in reverse.
2. Pull up to assist machine
3. Lower Control Bar engaged and mower going forward.

m-4185

### Driving Backward Up a Curb

1. Disengage the mower blades.
2. Select reverse to drive machine.
3. Drive the machine until drive wheels contact curb (Fig. 18).



**Note:** Both drive wheels should contact the curb and caster wheels straight.

4. At the same time engage lower control bar and lift up on handle (Fig. 17 and 18).

**Note:** Lifting up on handle will assist driving the machine up a curb and not spin the drive wheels.

## Stopping the Machine

To stop the machine, pull back on the upper control bar, release the blade control bail (PTO), and turn the ignition key to **off**. Also set the parking brake if you leave the machine unattended; refer to Setting the Parking Brake, page 19. Remember to remove the key from the ignition switch.

 **Caution** 

Children or bystanders may be injured if they move or attempt to operate the machine while it is unattended.

Always remove the ignition key and set the parking brake when leaving the machine unattended, even if just for a few minutes.

## Transporting Machines

Use a heavy-duty trailer or truck to transport the machine. Ensure that the trailer or truck has all necessary lighting and marking as required by law. Please carefully read all the safety instructions. Knowing this information could help you, your family, pets or bystanders avoid injury.

To transport the machine:

- Stop engine, remove key, lock brake, shut-off fuel valve and block wheels.
- Securely fasten the machine to the trailer or truck with straps, chains, cable, or ropes.
- Secure a trailer to towing vehicle with safety chains.

## Side Discharge or Mulch Grass

This mower has a hinged grass deflector that disperses clippings to the side and down toward the turf.

! **Danger** !

**Without the grass deflector, discharge cover, or complete grass catcher assembly mounted in place, you and others are exposed to blade contact and thrown debris. Contact with rotating mower blade(s) and thrown debris will cause injury or death.**

- **Never remove the grass deflector from the mower because the grass deflector routes material down toward the turf. If the grass deflector is ever damaged, replace it immediately.**
- **Never put your hands or feet under the mower.**
- **Never try to clear discharge area or mower blades unless you release the bail and the power take off (PTO) is off. Rotate the ignition key to off. Also remove the key and pull the wire off the spark plug(s).**

## Adjusting the Height-of-Cut

The height-of-cut can be adjusted from 1 to 4-1/2 inch (25 to 114 mm) in 1/4 inch (6 mm) increments. Adjustment is done by relocating four hairpin cotter pins in different hole location and by adding or removing spacers.

**Note:** All height-of-cut pins need at least one spacer or damage can occur to bushing if none are used.

**Note:** All height-of-cut pins can use only two spacers maximum.

1. Select hole in height-of-cut post and number of spacers corresponding to the height-of-cut desired (Fig. 19).
2. Using lift handle, raise side of deck and remove hairpin cotter (Fig. 19).
3. Add or remove spacers if needed and then align holes and insert hairpin cotter (Fig. 19).

**Note:** Spare height-of-cut spacers may be stored on posts and retained by a hairpin cotter.

**Important** All four hairpin cotter pins must be in the same hole location and with the correct number of spacers for a level cut.

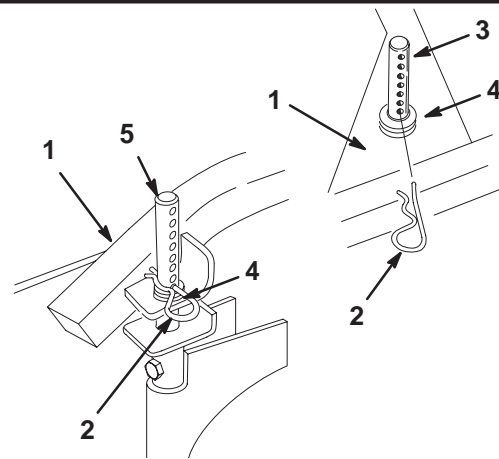
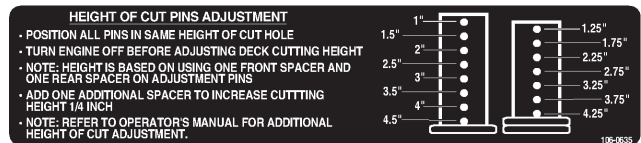

Figure 19

1. Carrier Frame
2. Hairpin Cotter
3. Front height-of-cut post
4. Spacers
5. Back height-of-cut post

## Adjusting the Gage Wheels

The gage wheels need to be adjusted in the proper hole location for each height-of-cut position. There needs to be 3/8 inch (10 mm) minimum clearance above the ground.

1. After adjusting height-of-cut, check the gage wheels so that there is a minimum of 3/8 inch (10 mm) clearance above the ground (Figures 20 and 21).
2. If adjustment is needed, remove the bolt, washer(s) and nut (Figures 20 and 21).
3. Select a hole position so the gage wheels are a minimum of 3/8 inch (10 mm) off the ground (Figures 20 and 21).
4. Install the bolt, washer(s) and nut (Figures 20 and 21).

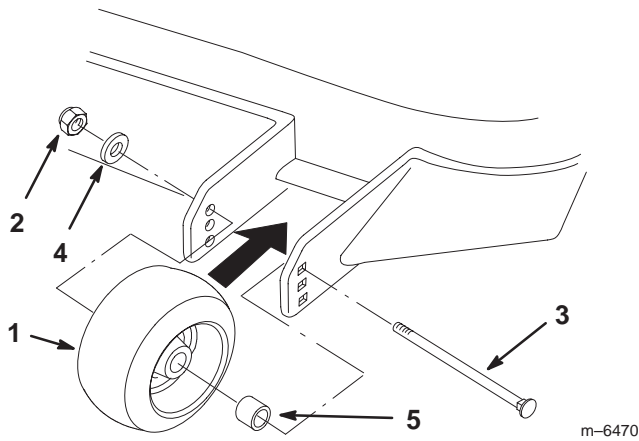

**Figure 20**

m-6470

- |               |           |
|---------------|-----------|
| 1. Gage wheel | 4. Washer |
| 2. Nut        | 5. Spacer |
| 3. Bolt       |           |

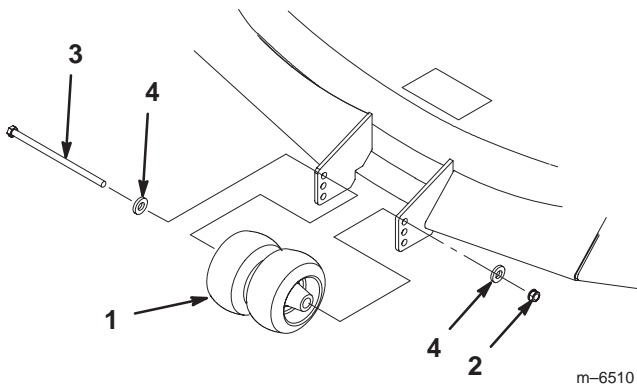

**Figure 21**

m-6510

- |                                     |           |
|-------------------------------------|-----------|
| 1. Center Gage Wheels and<br>Spacer | 3. Bolt   |
| 2. Nut                              | 4. Washer |

## Adjusting the Handle Height

The handle position can be adjusted to match the operator's height preference.

1. Remove hairpin cotter, washer and clevis pin securing control rod fitting to idler bracket (Fig. 22).
2. Loosen the upper flange bolts (3/8 x 1 inch) and flange nut securing handle to rear frame (Fig. 22).
3. Remove the lower flange bolts (3/8 x 1 inch) and flange nuts securing handle to rear frame (Fig. 22).
4. Pivot handle to desired operating position and install lower flange bolts (3/8 x 1 inch) and flange nuts into mounting holes. Tighten all flange bolts.

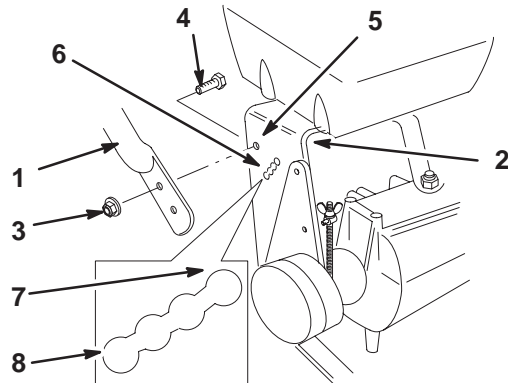

m-6403

**Figure 22**

- |                              |                         |
|------------------------------|-------------------------|
| 1. Upper handle              | 5. Upper mounting hole  |
| 2. Rear frame                | 6. Lower mounting holes |
| 3. Flange nut, 3/8 inch      | 7. Low position         |
| 4. Flange bolt, 3/8 x 1 inch | 8. High position        |

5. Thread rod fitting up or down on rod until proper position is attained and install into fitting to idler bracket with clevis pin, washer and hairpin cotter.
6. Check the parking brake adjustment (Fig. 10). Refer to Checking the Brakes, page 30.

## Using the Mid-Size Weight Kit

A weight kit is available for this machine. This kit is optional and can be obtained from an Authorized Service Dealer

- The weight kit mounted in the **front** position is **required** when a Tru-Trak<sup>®</sup> Sulky is installed.
- The weight kit mounted in the **back** position is **optional** when a Tru-Trak<sup>®</sup> Sulky is not installed.
- Installing this weight kit can improve performance on slopes without the Tru-Trak<sup>®</sup> Sulky.

# Maintenance



**Note:** Determine the left and right sides of the machine from the normal operating position.

## Recommended Maintenance Schedule

Maintenance Service Interval	Maintenance Procedure
Each Use	<ul style="list-style-type: none"> <li>• Oil—check level</li> <li>• Safety System—check</li> <li>• Brake—check</li> <li>• Engine—clean outside</li> <li>• Mower Housing—clean</li> </ul>
8 Hours	<ul style="list-style-type: none"> <li>• Mower Housing—clean</li> <li>• Caster Wheels—grease</li> <li>• Caster Pivot—grease</li> <li>• Cutting Blades—check</li> </ul>
25 Hours	<ul style="list-style-type: none"> <li>• Foam Air Cleaner—clean<sup>1</sup></li> <li>• Paper Air Cleaner—clean<sup>1</sup></li> </ul>
40 Hours	<ul style="list-style-type: none"> <li>• Tires—check pressure</li> <li>• PTO Belt Idler Arm—grease</li> </ul>
50 Hours	<ul style="list-style-type: none"> <li>• Belts—check</li> </ul>
100 Hours	<ul style="list-style-type: none"> <li>• Oil—change<sup>1</sup></li> <li>• Electric Clutch—adjust</li> <li>• Engine—clean outside</li> <li>• Paper Air Cleaner—replace</li> </ul>
200 Hours	<ul style="list-style-type: none"> <li>• Fuel Filter—replace</li> <li>• Oil Filter—change (200 hours or every other oil change)</li> <li>• Spark Plug(s)—check</li> </ul>
250 Hours	<ul style="list-style-type: none"> <li>• Transmission Couplings—grease<sup>1</sup></li> </ul>
400 Hours	<ul style="list-style-type: none"> <li>• Wheel Bearings—grease<sup>1</sup></li> </ul>
At storage	<ul style="list-style-type: none"> <li>• Chipped Surfaces—paint</li> <li>• Perform all maintenance procedures listed above before storage</li> </ul>

<sup>1</sup>More often in dusty, dirty conditions.

**Important** Refer to your engine operator's manual for additional maintenance procedures.

Caution

**If you leave the key in the ignition switch, someone could accidentally start the engine and seriously injure you or other bystanders.**

**Remove the key from the ignition and disconnect the spark plug wire from the spark plug(s) before you do any maintenance. Set the wire aside so that it does not accidentally contact the spark plug.**

# Servicing the Air Cleaner

## Service Interval/Specification

Foam Element: Clean and re-oil after every 25 operating hours.

Paper Element: Clean after every 25 operating hours.  
Replace after every 100 operating hours.

**Note:** Service the air cleaner more frequently if operating conditions are extremely dusty or sandy.

## Removing the Foam and Paper Elements

1. Disengage the power take off (PTO), set the parking brake, and turn the ignition key to off. Remove the key.
2. Clean around the air cleaner to prevent dirt from getting into the engine and causing damage. Unscrew the cover nut and remove the air cleaner cover (Fig. 23).
3. Remove the air cleaner assembly (Fig. 23).
4. Carefully slide the foam element off the paper element (Fig. 23).

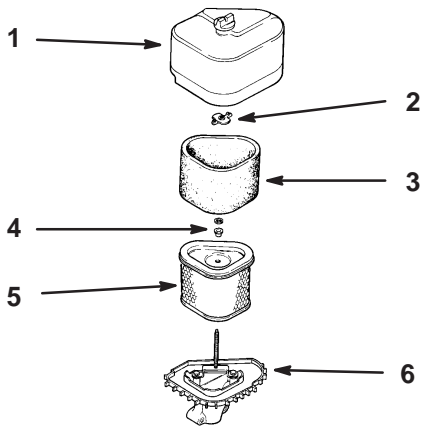

Figure 23

- |                  |                       |
|------------------|-----------------------|
| 1. Cover and nut | 4. Washer and grommet |
| 2. Wing nut      | 5. Paper element      |
| 3. Foam element  | 6. Air cleaner base   |

## Cleaning the Foam Elements

1. Wash the foam element in liquid soap and warm water. When the element is clean, rinse it thoroughly.
2. Dry the element by squeezing it in a clean cloth.
3. Put one or two ounces of oil on the element (Fig. 24). Squeeze the element to distribute the oil.

**Important** Replace the foam element if it is torn or worn.

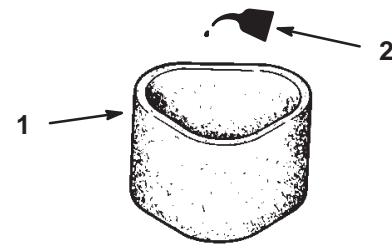

Figure 24

- |                 |        |
|-----------------|--------|
| 1. Foam element | 2. Oil |
|-----------------|--------|

## Cleaning the Paper Element

1. Lightly tap the element on a flat surface to remove dust and dirt (Fig. 25).
2. Inspect the element for tears, an oily film, and damage to the rubber seal.

**Important** Never clean the paper element with pressurized air or liquids, such as solvent, gas, or kerosene. Replace the paper element if it is damaged, defective, or cannot be cleaned thoroughly.

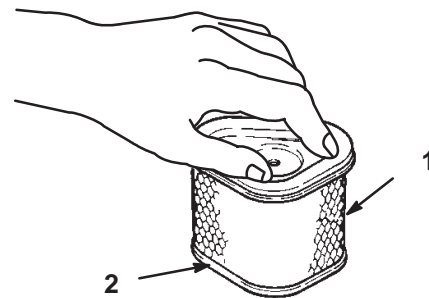

Figure 25

- |                  |                |
|------------------|----------------|
| 1. Paper element | 2. Rubber seal |
|------------------|----------------|

## Installing the Foam and Paper Elements

1. Installing the Foam and Paper Elements

**Important** To prevent engine damage, always operate the engine with the complete foam and paper air cleaner assembly installed.

1. Carefully slide the foam element onto the paper air cleaner element (Fig. 23).
2. Place the air cleaner assembly onto the air cleaner base (Fig. 23).
3. Install the air cleaner cover and secure with cover nuts (Fig. 23).

# Servicing the Engine Oil

## Service Interval/Specification

Change oil:

- After every 100 operating hours.

**Note:** Change oil more frequently when operating conditions are extremely dusty or sandy.

Oil Type: Detergent oil (API service SF, SG or SH)

Crankcase Capacity: w/filter, 64 oz. (1.9 l)

Viscosity: See table below

### USE THESE SAE VISCOSITY OILS

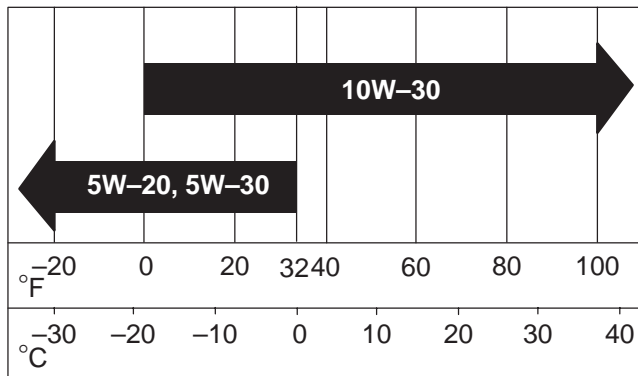

## Checking the Oil Level

1. Park the machine on a level surface, disengage the power take off (PTO), set the parking brake, and turn the ignition key to off. Remove the key.
2. Clean around the oil dipstick (Fig. 26) so dirt cannot fall into the filler hole and damage the engine.
3. Unscrew the oil dipstick and wipe the metal end clean (Fig. 26).
4. Slide the oil dipstick fully into the filler tube, do not thread onto tube (Fig. 26). Pull the dipstick out and look at the metal end. If oil level is low, slowly pour only enough oil into the filler tube to raise the level to the full mark.

**Important** Do not overfill the crankcase with oil because the engine may be damaged.

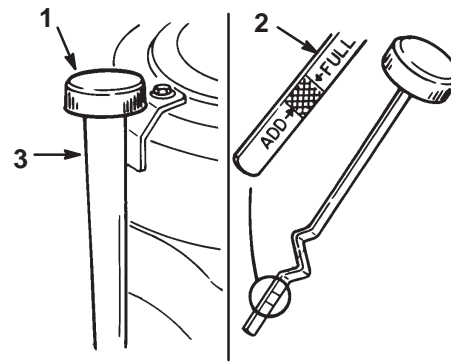

**Figure 26**

1. Oil dipstick
2. Metal end
3. Filler tube

## Changing the Oil

1. Start the engine and let it run five minutes. This warms the oil so it drains better.
2. Park the machine so that the drain side is slightly lower than the opposite side to assure the oil drains completely.
3. Disengage the power take off (PTO), set the parking brake, and turn the ignition key to off. Remove the key.
4. Slide the drain hose over the drain valve.
5. Place a pan below the drain hose. Rotate the drain valve to allow the oil to drain (Fig. 27).
6. When the oil has drained completely, close the oil drain valve and remove the drain hose (Fig. 27).

**Note:** Dispose of the used oil at a certified recycling center.

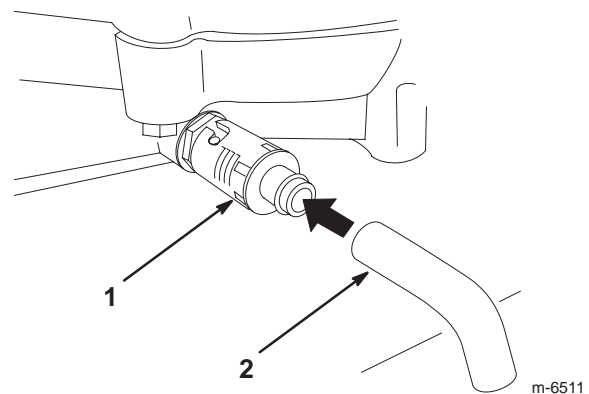

**Figure 27**

1. Oil drain valve
2. Oil drain hose

7. Slowly pour approximately 80% of the specified oil into the filler cap (Fig. 26). Refer to Servicing the Engine Oil, page 26.

8. Check the oil level; refer to Checking the Oil Level, page 26.
9. Slowly add additional oil to bring it to the full mark.

## Changing the Oil Filter

### Service Interval/Specification

Replace the oil filter every 200 hours or every other oil change.

**Note:** Change oil filter more frequently when operating conditions are extremely dusty or sandy.

1. Drain the oil from the engine; refer to Changing the Oil, page 26.
2. Remove the old filter and wipe the filter adapter (Fig. 28) gasket surface.
3. Apply a thin coat of new oil to the rubber gasket on the replacement filter (Fig. 28).

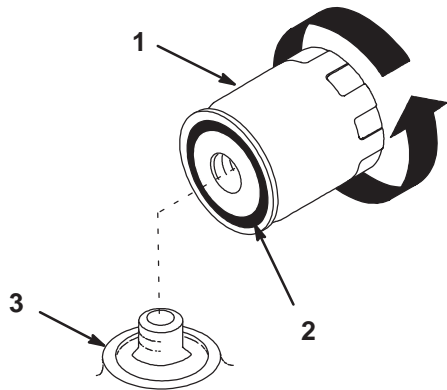

m-1256

**Figure 28**

1. Oil filter
2. Gasket
3. Adapter

4. Install the replacement oil filter to the filter adapter. Turn the oil filter clockwise until the rubber gasket contacts the filter adapter, then tighten the filter an additional 1/2 turn (Fig. 28).
5. Fill the crankcase with the proper type of new oil; refer to Changing the Oil, page 26.

## Servicing the Spark Plug

### Service Interval/Specification

Check the spark plug(s) after every 200 operating hours. Make sure the air gap between the center and side electrodes is correct before installing the spark plug. Use a spark plug wrench for removing and installing the spark plug(s) and a gapping tool/feeler gauge to check and adjust the air gap. Install a new spark plug(s) if necessary.

Type: Champion® RC12YC or Champion® Premium Gold 2071 (or equivalent)

Air Gap: 0.040 in. (1.02 mm)

### Removing the Spark Plug(s)

1. Disengage the power take off (PTO), set the parking brake, and turn the ignition key to off. Remove the key.
2. Pull the wire(s) off the spark plug(s) (Fig. 29). Now clean around the spark plug(s) to prevent dirt from falling into the engine and potentially causing damage.
3. Remove the spark plug(s) and metal washer.

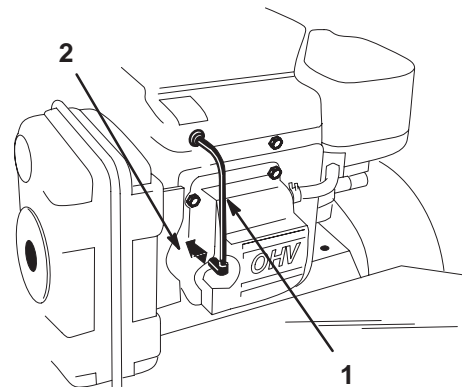

m-4757

**Figure 29**

1. Spark plug wire
2. Spark plug

### Checking the Spark Plug

1. Look at the center of the spark plug(s) (Fig. 30). If you see light brown or gray on the insulator, the engine is operating properly. A black coating on the insulator usually means the air cleaner is dirty.

**Important** Never clean the spark plug(s). Always replace the spark plug(s) when it has: a black coating, worn electrodes, an oily film, or cracks.

2. Check the gap between the center and side electrodes (Fig. 30). Bend the side electrode (Fig. 30) if the gap is not correct.

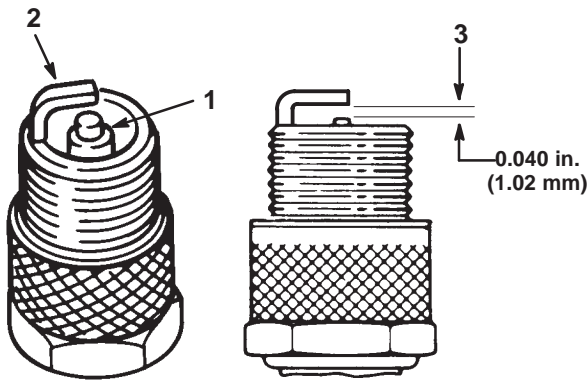

**Figure 30**

1. Center electrode insulator
2. Side electrode
3. Air gap (not to scale)

## Installing the Spark Plug(s)

1. Install the spark plug(s) and metal washer. Make sure the air gap is set correctly.
2. Tighten the spark plug(s) to 30 ft-lb (41 N.m).
3. Push the wire(s) onto the spark plug(s) (Fig. 29).

## Greasing and Lubrication

### Service Interval/Specification

Grease with No. 2 general purpose lithium base or molybdenum base grease.

### How to Grease

1. Disengage the PTO and set the parking brake.
2. Stop the engine, remove the key, and wait for all moving parts to stop before leaving the operating position.
3. Clean the grease fittings with a rag. Make sure to scrape any paint off the front of the fitting(s).
4. Connect a grease gun to the fitting. Pump grease into the fittings until grease begins to ooze out of the bearings.
5. Wipe up any excess grease.

### Lubricating the Caster and Wheel Bearings

1. Lubricate the front wheel bearings and front spindles until grease begins to ooze out of the bearings (Fig. 31).

2. Raise the rear of the machine and use jack stands to support the machine.
3. Remove the rear wheel and tire assembly.
4. Remove rear wheel grease cap. Lubricate the rear wheel bearing (Fig. 31).
5. Install the grease cap.
6. Install the rear wheel and tire assembly.

**Note:** Make sure the rear wheel grease caps are removed before lubricating rear wheels.

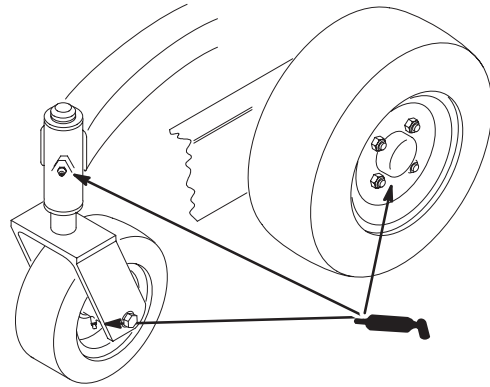
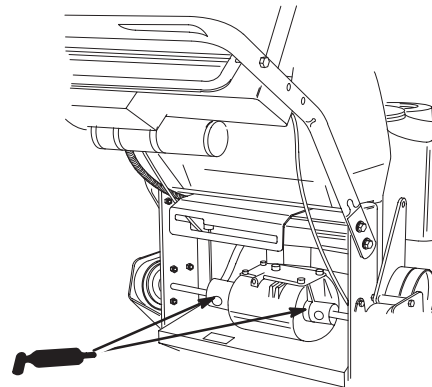

**Figure 31**

m-6367

## Lubricating the Transmission Couplers

1. Lubricate the transmission couplers located in the back of the machine (Fig. 32).



**Figure 32**

m-5191

## Greasing the PTO Drive Belt Idler and Deck Belt Idler

1. Stop the engine, set the parking brake, remove the key and disconnect the spark plug wire(s) from the spark plug(s).
2. Grease the idler pulley pivots (Fig. 33).

**Note:** You will have to remove the carrier covers to access the grease fitting for the deck.

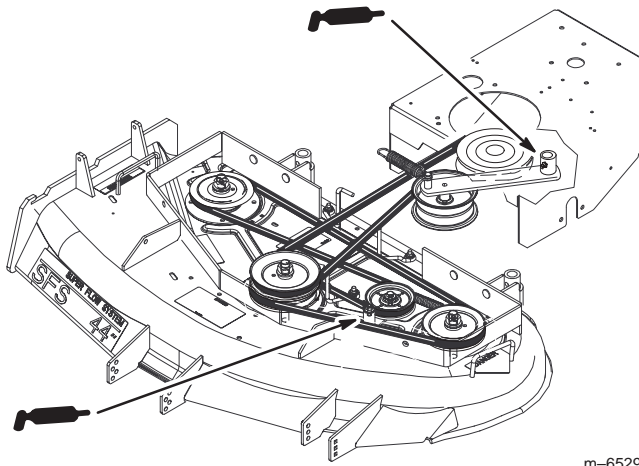

**Figure 33**

m-6529

## Cleaning the Cooling System

### Service Interval/Specification

Before each use, check and clean engine cooling system. Remove any build-up of grass, dirt or other debris from the cylinder and cylinder head cooling fins, air intake screen on flywheel end, and carburetor-governor levers and linkage. This will help insure adequate cooling and correct engine speed and will reduce the possibility of overheating and mechanical damage to the engine.

## Checking the Tire Pressure

### Service Interval/Specification

Maintain the air pressure in the front and rear tires as specified. Check the pressure at the valve stem after every 40 operating hours or monthly, whichever occurs first (Fig. 34). Check the tires when they are cold to get the most accurate pressure reading.

Rear Tire Pressure: 12–14 psi (83–97 kPa)

Caster Tire Pressure: 25–30 psi (172–207 kPa)

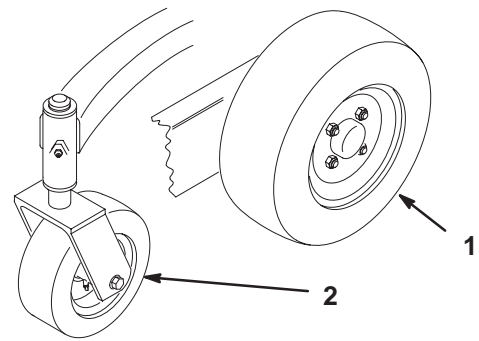

m-6367

**Figure 34**

1. Rear Tire
2. Caster tire

## Servicing the Fuse

### Service Interval/Specification

The electrical system is protected by a fuse. It requires no maintenance. If the fuse blows check component or circuit for malfunction or short. To replace fuse pull out on the fuse (Fig. 35) to remove or replace it.

Fuse: F1–7.5 amp, blade-type

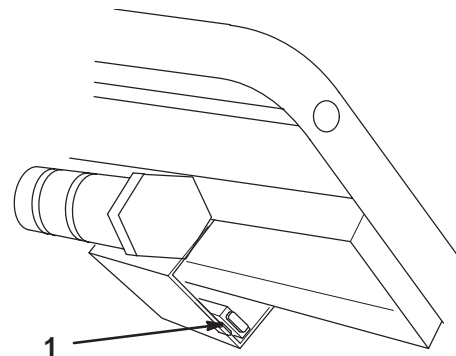

m-5206

**Figure 35**

1. Fuse 7.5 amp

## Servicing the Brakes

### Service Interval/Specification

Before each use, check brakes on both a level surface and slope.

Always set the parking brake when you stop the machine or leave it unattended. If the parking brake does not hold securely, an adjustment is required.

## Checking the Brakes

1. Park the machine on a level surface, disengage the PTO.
2. Stop the engine, remove the key, and wait for all moving parts to stop before leaving the operating position.
3. Apply the parking brake. The wheels must lock when you try to push the machine forward.
4. If the wheels do not lock, adjust the brakes. Refer to Adjusting the Brakes on page 30.
5. Release the brake and press upper control bar very lightly, approximately 1/2 inch (13 mm). The wheels should rotate freely, if not; refer to Adjusting the Brake, page 30.

## Adjusting the Brakes

The brake lever is on the upper control bar (Fig. 13). If the parking brake does not hold securely, an adjustment is required.

**Note:** For the initial adjustment, adjust the wing nut until it is 1-1/4 inches from the top of the rod (Fig. 36).

1. Park the machine on a level surface, disengage the PTO, and set the parking brake.
2. Stop the engine, remove the key, and wait for all moving parts to stop before leaving the operating position.
3. Check the brake before you adjust it; refer to Checking the Brakes, page 30.
4. Release the parking brake; refer to Releasing the Parking Brake, page 19.
5. To adjust the brake remove the hair pin cotter and washer from the brake lever and trunnion (Fig. 36).
6. Rotate the wing nut clockwise to increase the braking pressure.
7. Rotate the wing nut counterclockwise to decrease the braking pressure.
8. Install the trunnion into hole **F** (Fig. 36). Tighten the wing nut.
9. Secure trunnion to brake lever with washer and hair pin cotter (Fig. 36).
10. Check the brake operation again; refer to Checking the Brake, page 30.

**Important** With the parking brake released, the rear wheels must rotate freely when you push the mower. If brake action and free wheel rotation cannot be achieved contact your service dealer immediately.

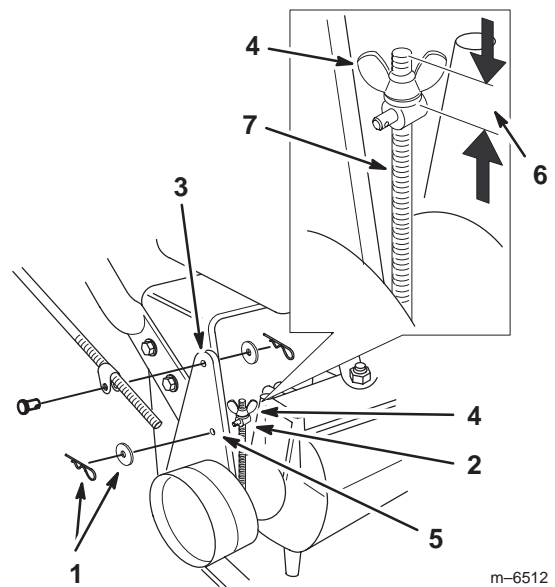

Figure 36

m-6512

- |                              |  |
|------------------------------|--|
| 1. Hairpin cotter and washer | 5. Hole <b>F</b>                             |
| 2. Trunnion                  | 6. Initial adjustment—<br>1-1/4 inch (32 mm) |
| 3. Brake lever               | 7. Rod                                       |
| 4. Wing nut                  |  |

## Adjusting the Electric Clutch

The clutch is adjustable to ensure proper engagement and proper braking. Check adjustment after every 100 hours of operation.

1. To adjust clutch, tighten or loosen lock nuts on flange studs (Fig. 37).
2. Check adjustment by inserting feeler gauge thru slots next to studs (Fig. 37).
3. The proper disengaged clearance between the clutch plates is 0.012–.018 inch (0.30-0.45 mm). It will be necessary to check this clearance at each of the three slots to ensure the plates are parallel to each other.

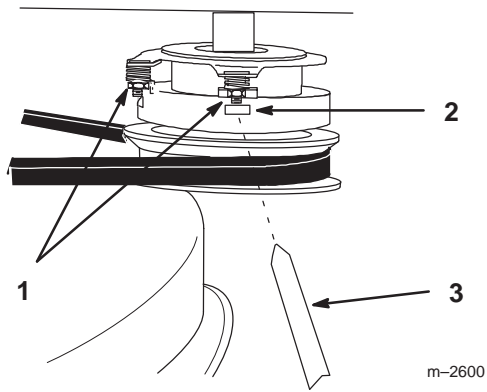

**Figure 37**

1. Adjusting nut  
2. Slot  
3. Feeler gauge

5. Install the fuel line onto the valve. Slide the hose clamp close to the valve to secure the fuel line.

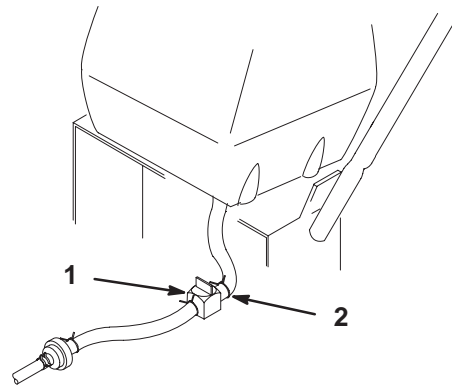

**Figure 38**

1. Fuel shut-off valve  
2. Clamp

## Servicing the Fuel Tank

! **Danger** !

**In certain conditions, gasoline is extremely flammable and highly explosive. A fire or explosion from gasoline can burn you and others and can damage property.**

- Drain gasoline from the fuel tank when the engine is cold. Do this outdoors in an open area. Wipe up any gasoline that spills.
- Never smoke when draining gasoline, and stay away from an open flame or where a spark may ignite the gasoline fumes.

### Draining the Fuel Tank

1. Park the machine on a level surface, to assure fuel tank drains completely. Then disengage the power take off (PTO), set the parking brake, and turn the ignition key to **off**. Remove the key.
2. Close fuel shut-off valve at fuel tank (Fig. 38).
3. Squeeze the ends of the hose clamp together and slide it up the fuel line away from valve (Fig. 38).
4. Pull the fuel line off the valve (Fig. 38). Open fuel shut-off valve and allow gasoline to drain into a gas can or drain pan.

**Note:** Now is the best time to install a new fuel filter because the fuel tank is empty. Refer to Replacing the Fuel Filter; page 31.

## Servicing the Fuel Filter

### Service Interval/Specification

Replace the fuel filter after every 200 operating hours or yearly, whichever occurs first.

### Replacing the Fuel Filter

Never install a dirty filter if it is removed from the fuel line.

**Note:** Note how the fuel filter is installed.

1. Disengage the PTO and set the parking brake.
2. Stop the engine, remove the key, and wait for all moving parts to stop before leaving the operating position.
3. Close fuel shut-off valve at fuel tank (Fig. 38).

**Note:** Remove fuel line from fuel valve that is closest to the engine.

4. Squeeze the ends of the hose clamps together and slide them away from the filter (Fig. 39).
5. Remove the filter from the fuel lines.
6. Install a new filter and move the hose clamps close to the filter.
7. Open fuel shut-off valve at fuel tank (Fig. 38).
8. Check for fuel leaks and repair if needed (Fig. 38).

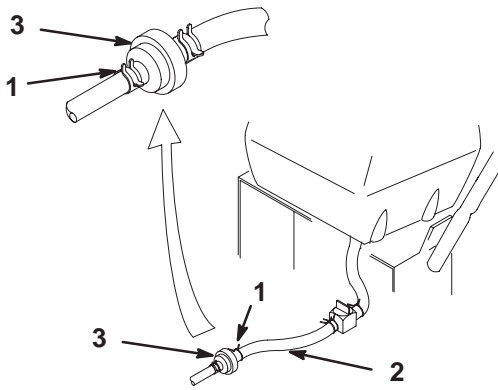

**Figure 39**

- 1. Hose clamp
- 2. Fuel line
- 3. Filter

m-5234

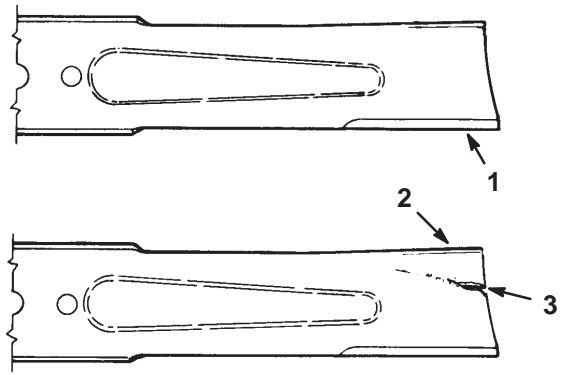

**Figure 40**

- 1. Cutting Edge
- 2. Curved Area
- 3. Wear/slot Forming

m-151

## Servicing the Cutting Blades

To ensure a superior quality of cut, keep the blades sharp. For convenient sharpening and replacement, you may want to keep extra blades on hand.

**Warning**

**A worn or damaged blade can break, and a piece of the blade could be thrown into the operator's or bystander's area, resulting in serious personal injury or death.**

- **Inspect the blade periodically for wear or damage.**
- **Replace a worn or damaged blade.**

### Before Inspecting or Servicing the Blades

Park the machine on a level surface, disengage the blade control (PTO) and set the parking brake. Turn the ignition key to **off**. Remove the key and disconnect the spark plug wire(s) from the spark plug(s).

### Inspecting the Blades

1. Inspect the cutting edges (Fig 40). If the edges are not sharp or have nicks, remove and sharpen the blades. Refer to Sharpening the Blades on page 33.
2. Inspect the blades, especially the curved area (Fig. 40). If you notice any damage, wear, or a slot forming in this area (item 3 in Fig. 40), immediately install a new blade.

### Checking for Bent Blades

1. Rotate the blades until the ends face forward and backward (Fig. 41). Measure from a level surface to the cutting edge, position A, of the blades (Fig. 42). Note this dimension.

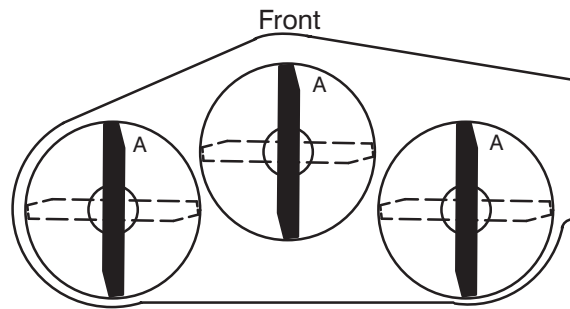

**Figure 41**

m-1078

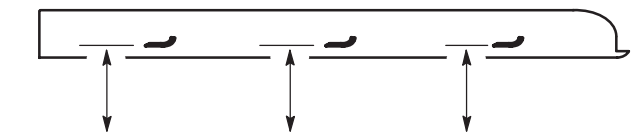

**MEASURE FROM  
CUTTING EDGE TO A  
LEVEL SURFACE**

**Figure 42**

m-2539

2. Rotate the opposite ends of the blades forward.
3. Measure from a level surface to the cutting edge of the blades at the same position as in step 1. The difference between the dimensions obtained in steps 1 and 2 must not exceed 1/8 inch (3 mm). If this dimension exceeds

1/8 inch (3 mm), the blade is bent and must be replaced. Refer to Removing the Blades, and Installing the Blades on page 33.

**Warning**

**A blade that is bent or damaged could break apart and could seriously injure or kill you or bystanders.**

- Always replace bent or damaged blade with a new blade.
- Never file or create sharp notches in the edges or surfaces of blade.

## Removing the Blades

Blades must be replaced if a solid object is hit, if the blade is out of balance or is bent. To ensure optimum performance and continued safety conformance of the machine, use genuine TORO replacement blades. Replacement blades made by other manufacturers may result in non-conformance with safety standards.

1. Hold the blade end using a rag or thickly-padded glove. Remove the blade bolt, washer, lock washer and blade from the spindle shaft (Fig. 43).

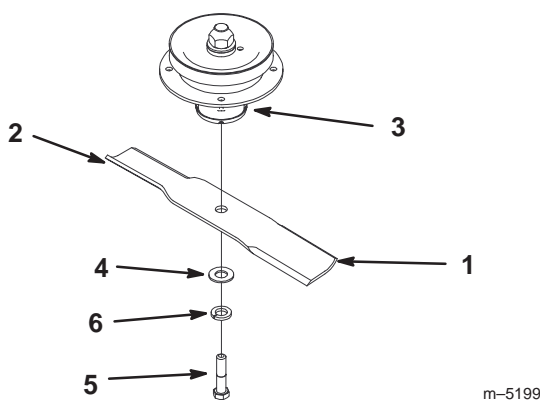
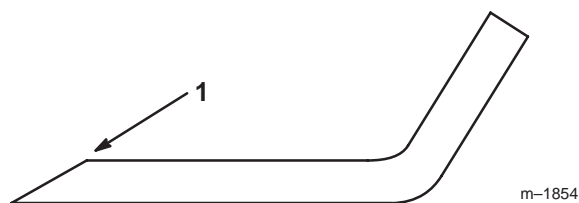

**Figure 43**

- |                       |                |
|-----------------------|----------------|
| 1. Sail Area of Blade | 4. Washer      |
| 2. Blade              | 5. Blade bolt  |
| 3. Blade spindle      | 6. Lock washer |

## Sharpening the Blades

1. Use a file to sharpen the cutting edge at both ends of the blade (Fig. 44). Maintain the original angle. The blade retains its balance if the same amount of material is removed from both cutting edges.



**Figure 44**

1. Sharpen at original angle

2. Check the balance of the blade by putting it on a blade balancer (Fig. 45). If the blade stays in a horizontal position, the blade is balanced and can be used. If the blade is not balanced, file some metal off the end of the sail area only (Fig. 43). Repeat this procedure until the blade is balanced.

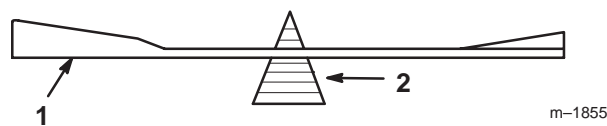

**Figure 45**

1. Blade
2. Balancer

## Installing the Blades

1. Install the blade onto the spindle shaft (Fig. 43).

**Important** The sail part of the blade must be pointing upward, toward the inside of the mower to ensure proper cutting (Fig. 43).

2. Install the lock washer and blade bolt (Fig. 43). Torque the blade bolt to 85–110 ft-lb (115–140 N•m).

## Correcting the Mower Quality of Cut

If one deck blade cuts lower than the other, correct as follows.

**Note:** Tire air pressure is critical in these procedures. Make sure all tires have correct pressure.

1. Disengage the PTO and set the parking brake.
2. Stop the engine, remove the key, and wait for all moving parts to stop before leaving the operating position. Disconnect the spark plug wire(s) from the spark plug(s).
3. Adjust the tire pressure in all tires to specifications on page 29.
4. Check that the blades and spindle shafts are not bent. Refer to Checking for Bent Blades on page 32.

- Set the height-of-cut to the 4 inch (101.6 mm) position. Refer to Adjusting the Height-Of-Cut in the Operation section.
- Perform steps in the following sections Frame Set Up, Checking Front-to-Rear Pitch and Checking Side-to-Side Leveling.

## Frame Set Up

### Checking Carrier Frame and Deck Alignment

- Disengage the PTO and set the parking brake.
- Stop the engine, remove the key, and wait for all moving parts to stop before leaving the operating position.
- Place a long straight edge on top of the engine deck as shown in figure 46.
- At the carrier frame cross tube, measure location **A** height (Fig. 46). This measurement must be 1-5/16 inch (33 mm), plus or minus a 1/4 inch (6 mm).
- If the height at location **A** is not correct, adjustment is needed.
- Loosen the carrier frame mounting bolts on both sides of the machine (Fig. 46).
- Align the carrier frame and engine deck to match 1-5/16 inch (33 mm), plus or minus a 1/4 inch (6 mm) at location **A** (Fig. 46).
- Tighten the carrier frame mounting bolts on both sides of the machine.

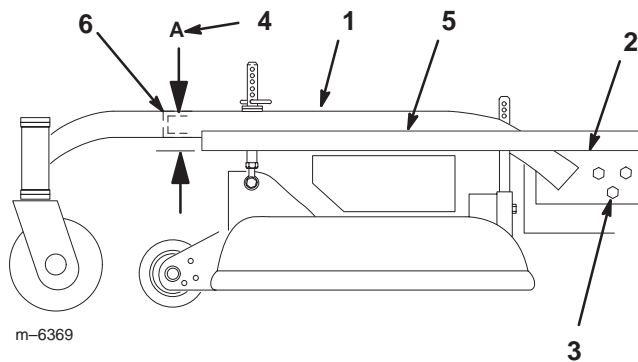
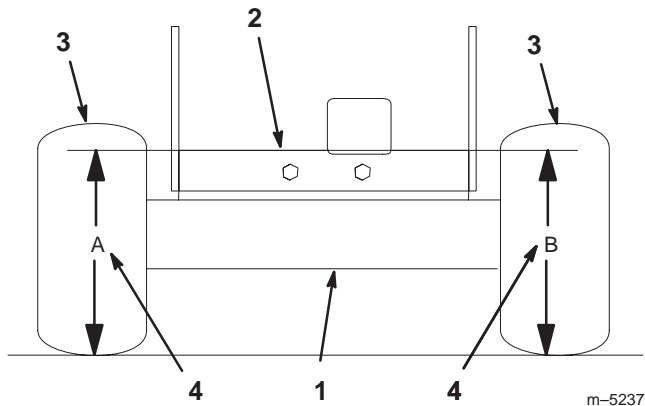

**Figure 46**

- |                                 |   |
|---------------------------------|---|
| 1. Carrier Frame                | 4. Location <b>A</b> , 1-5/16 inch (33 mm) ±1/4 inch (6 mm) |
| 2. Top of engine deck           | 5. Straight edge  |
| 3. Carrier frame mounting bolts | 6. Carrier frame cross tube                                 |

### Checking Engine Deck Height

- Disengage the PTO and set the parking brake.
- Stop the engine, remove the key, and wait for all moving parts to stop before leaving the operating position.
- Adjust the tire pressure in all tires to specifications on page 29.
- Measure engine deck height at location **A** (Fig. 47).
- Measure engine deck height at location **B** (Fig. 47).
- If the height at location **A** and **B** are not the same, change tire pressure slightly to make them the same.



**Figure 47**

- |                         |                                     |
|-------------------------|-------------------------------------|
| 1. Back view of machine | 4. Same height at locations A and B |
| 2. Top of engine deck   |                                     |
| 3. Tires                |                                     |

### Checking Carrier Frame Front-to-Rear Pitch

The carrier frame must have a pitch of a 1/4 inch (6 mm) over the length of 24 inches (61 cm) on the carrier frame (Fig. 48).

- Measure out 24 inches (61cm) on the carrier frame (Fig. 48).
- Measure carrier frame height at location **A** (Fig. 48).
- Measure carrier frame height at location **B** (Fig. 48).
- The height at location **A** must be a 1/4-3/8 inch (6 mm -10 mm) lower than location **B** (Fig. 48).
- If the carrier frame is not correct, move caster spacers to make it a 1/4-3/8 inch (6 -10 mm) pitch (Fig. 48). Move spacers from top or bottom to make the correct pitch.
- The tire pressure may also be adjusted slightly to make a 1/4 inch (6 mm) pitch.

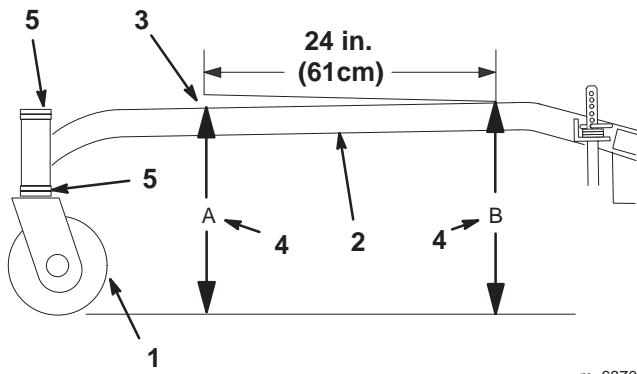

m-6370

**Figure 48**

- |  |                                |
|--|--------------------------------|
| 1. Caster Wheel  | 4. Height at locations A and B |
| 2. Carrier Frame   | 5. Caster spacers              |
| 3. 1/4–3/8 inch (6 mm–10 mm) pitch over 24 inch (61 cm) length |                                |

## Checking Carrier Frame Side-to-Side

1. Disengage the PTO and set the parking brake.
2. Stop the engine, remove the key, and wait for all moving parts to stop before leaving the operating position.
3. Adjust the tire pressure in all tires to specifications on page 29.
4. Measure carrier frame height at location **A** (Fig. 49).
5. Measure carrier frame height at location **B** (Fig. 49).
6. If the carrier frame height is not the same move spacers from top or bottom of caster wheel, to make it level. The tire pressure may also be adjusted slightly to make it level.

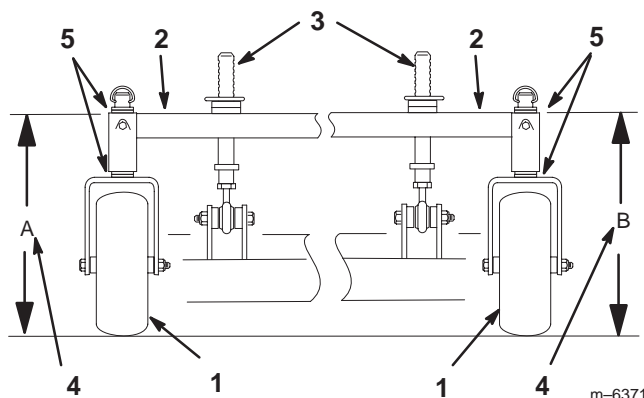

m-6371

**Figure 49**

- |                             |                                     |
|-----------------------------|-------------------------------------|
| 1. Caster Wheel             | 4. Same height at locations A and B |
| 2. Carrier Frame            | 5. Caster spacers                   |
| 3. Front height-of-cut pins |                                     |

## Checking the Deck Front-to-Rear Pitch

1. Check the tire pressure on both deck and traction unit.
2. Position one blade front-to-rear (Fig. 50). Measure at **C** and **D** locations (Fig. 50) from a level surface to the cutting edge of the blade tips (Fig. 51).
3. The mower blade should be **1/4 inch (6 mm) lower in front at C than in the rear at D**. Rotate blades and repeat for other blades. If it is not correct, proceed to Changing the Deck Front-to-Rear Pitch.

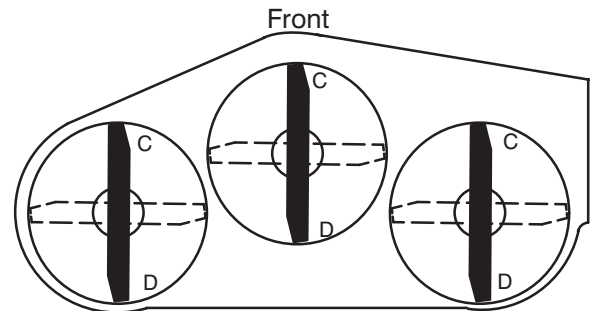

m-1078

**Figure 50**

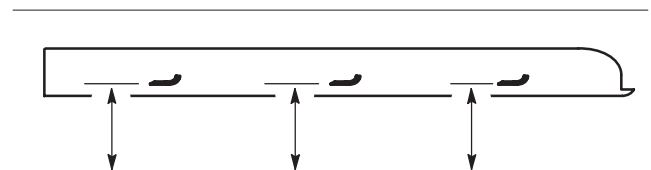

MEASURE FROM  
CUTTING EDGE TO A  
LEVEL SURFACE

m-2539

**Figure 51**

## Changing the Deck Front-to-Rear Pitch

Changing the front-to-rear pitch is done by adjusting the front height-of-cut posts.

### Changing the Deck Front-to-Rear Pitch by Adjusting Front Height-of-Cut Posts

1. To change the front-to-rear pitch, the front height-of-cut posts can be adjusted (Fig. 52).
2. To raise the front of the deck, loosen jam nut and rotate the front pin clockwise (Fig. 52).
3. To lower the front of the deck, loosen jam nut and rotate the front pin counter clockwise (Fig. 52).

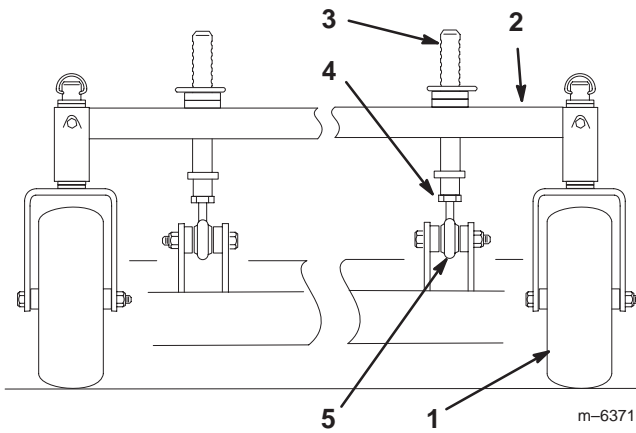

**Figure 52**

1. Caster Wheel
2. Carrier Frame
3. Front height-of-cut pins
4. Jam nut
5. Ball joint

4. Position the blades front-to-rear (Fig. 50). Measure at **C** and **D** locations (Fig. 50) from a level surface to the cutting edge of the blades (Fig. 51).
5. Check the side-to-side leveling of the cutting unit.

## Checking the Deck Side-to-Side Leveling

1. Check the tire pressure on both deck and traction unit.
2. Position the blades side-to-side (Fig. 53). Measure at **A** and **B** locations (Fig. 53) from a level surface to the cutting edge of blade tips (Fig. 54).
3. The difference between measurements **A** and **B** should be no more than 1/4 inch (6 mm).

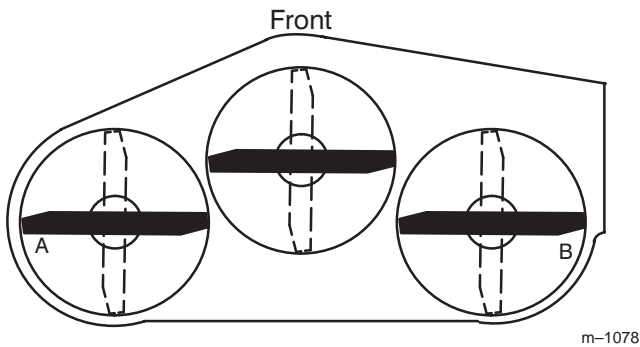

**Figure 53**

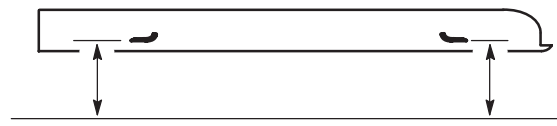

MEASURE FROM  
CUTTING EDGE TO  
A LEVEL SURFACE

m-2550

**Figure 54**

## Changing the Side-to-Side Leveling

Changing the side-to-side leveling is done by adjusting tire pressure.

### Changing the Side-to-Side Leveling with Tire Pressure

1. Change the tire pressure on both deck and traction unit. Do this to the corresponding side that needs adjustment.
2. Recheck the front-to-rear pitch and side to side leveling of the cutting unit.

## Matching Height of Cut

1. Check the tire pressure on both deck and traction unit.
2. Set the height-of-cut to the 4 inch (101.6 mm) position following the height-of-cut decal.
3. With the machine on level surface, position one blade front-to-rear (Fig. 55). Measure at **A** and from level surface to the cutting edge of the blade tips (Fig. 56).
4. The measurement should be 4 inch (101.6 mm).

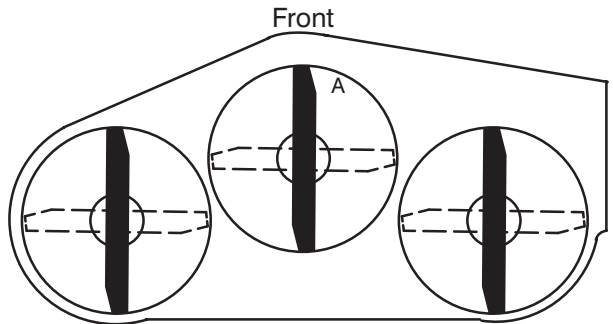

**Figure 55**

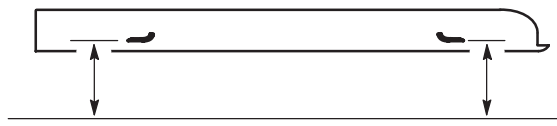

MEASURE FROM  
CUTTING EDGE TO  
A LEVEL SURFACE

m-2550

**Figure 56**

5. If it does not measure correctly, add air pressure in rear tires to raise height-of-cut
6. If it does not measure correctly, decrease air pressure in rear tires to lower height-of-cut.
7. Check carrier frame front-to-rear pitch.

## Replacing the Traction Drive Belt

### Service Interval/Specification

Check all belts after every 50 operating hours or monthly, whichever occurs first. Look for cracks, wear, and signs of overheating.

1. Remove the top capscrew securing idler support and idler bracket to rear frame (Fig. 57).
2. Loosen bottom two mounting screws enough to allow belt to pass between drive pulley and idler support (Fig. 57).
3. Raise the wheel off the ground, to allow the belt to be removed, and remove the belt.
4. Install a new belt.
5. Install the top capscrew securing the idler support and idler bracket to the rear frame (Fig. 57).
6. Tighten the bottom two mounting screws enough to allow the belt to pass between the drive pulley and idler support (Fig. 57).

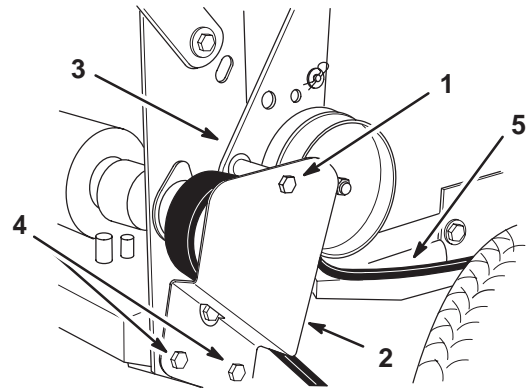

m-1722

**Figure 57**

- |                  |                        |
|------------------|------------------------|
| 1. Top capscrew  | 4. Bottom capscrew     |
| 2. Idler bracket | 5. Traction drive belt |
| 3. Idler support |                        |

## Replacing the Transmission Belt

1. Disengage the PTO and set the parking brake.
2. Stop the engine, remove the key, and wait for all moving parts to stop before leaving the operating position.
3. Remove PTO drive belt. Refer to Replacing the PTO Drive Belt on page 38.
4. Raise the front of the machine and hold with jack stands.
5. Disconnect clutch wire connector from wire harness.
6. Disconnect clutch retainer from the engine deck (Fig. 58).
7. Unhook tension spring from side of frame (Fig. 58).
8. Loosen pivot bolt enough to remove traction belt from the drive pulley and clutch.
9. Install new belt around clutch and drive pulley.
10. Torque pivot bolt to 35-40 ft-lb (47-54 N•m). Install tension spring between idler arm and frame bracket (Fig. 58).
11. Install clutch retainer to the engine deck (Fig. 58).
12. Connect clutch wire connector to wire harness.
13. Install PTO drive belt.

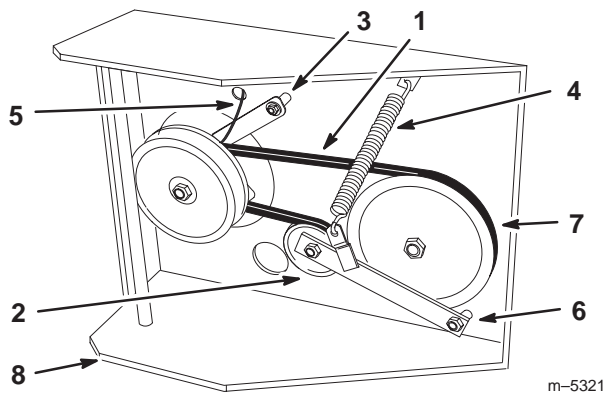

**Figure 58**

- |                      |                          |
|----------------------|--------------------------|
| 1. Transmission belt | 5. Clutch wire connector |
| 2. Idler pulley      | 6. Pivot bolt            |
| 3. Clutch retainer   | 7. Drive pulley          |
| 4. Tension spring    | 8. Engine deck           |

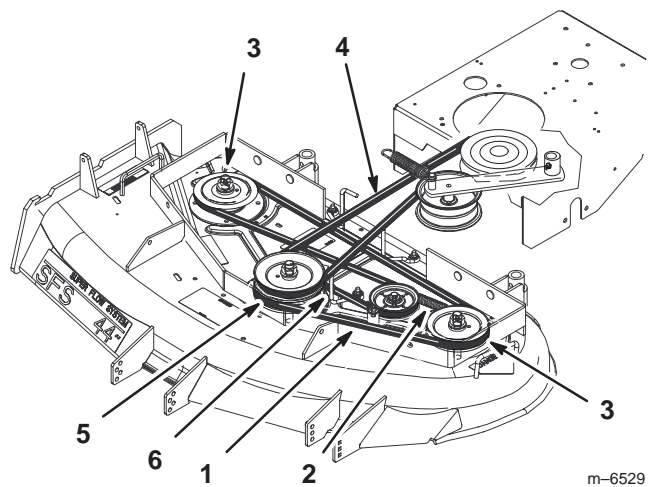

**Figure 59**

- |                     |                          |
|---------------------|--------------------------|
| 1. Deck belt        | 4. PTO drive Belt        |
| 2. Idler arm spring | 5. Center Spindle Pulley |
| 3. Outside pulley   | 6. Deck belt guide       |

## Replacing the Mower Belt

Squealing when the belt is rotating, blades slipping when cutting grass, frayed belt edges, burn marks and cracks are signs of a worn deck belt. Replace the deck belt if any of these conditions are evident.

1. Stop the engine, remove the key and disconnect the spark plug wire(s) from the spark plug(s).
2. Remove the knobs holding the carrier frame cover and remove the carrier frame cover.
3. Remove the knobs holding the belt covers to the cutting unit and remove the belt covers.
4. Remove the PTO drive belt. Refer to Replacing the PTO Drive Belt on page 38.
5. Disconnect the idler arm spring to relieve tension on the idler arm and idler pulley, then remove the worn deck belt (Fig. 59).
6. Install the new deck belt around the two outside spindle pulleys, the idler pulley, and in the lower groove of the center spindle pulley (Fig. 59).
7. Connect the idler arm spring (Fig. 59).
8. Reinstall the PTO drive belt. Refer to Replacing the PTO Drive Belt page 38.
9. Adjust deck belt guide an 1/8 inch (3 mm) from belt (Fig. 59).
10. Reinstall the deck covers onto the cutting unit, then reinstall and tighten the knobs.
11. Install the carrier frame cover onto the cutting unit, then install and tighten the hand knobs.

## Replacing the PTO Drive Belt

Squealing when the belt is rotating, blades slipping when cutting grass, frayed belt edges, burn marks and cracks are signs of a worn drive belt. Replace the drive belt if any of these conditions are evident.

1. Stop the engine, remove the key and disconnect the spark plug wire(s) from the spark plug(s).
2. Remove the knobs holding the carrier frame cover and remove the carrier frame cover.
3. Remove the knobs holding the belt covers to the top of the cutting unit and remove the belt covers.
4. Remove the idler spring from idler arm. Remove the drive belt from the PTO engagement pulley and the center spindle pulley (Fig. 60).
5. Remove the worn drive belt (Fig. 60).
6. Install the new drive belt onto the PTO engagement pulley and the top groove of the center spindle pulley (Fig. 60).
7. Install belt onto idler pulley and then install idler spring (Fig. 60).
8. Adjust PTO drive belt guides an 1/8 inch (3 mm) from belt (Fig. 60).
9. Install the belt covers onto the cutting unit, then install and tighten the knobs.
10. Install the carrier frame cover onto the cutting unit, then install and tighten the hand knobs.

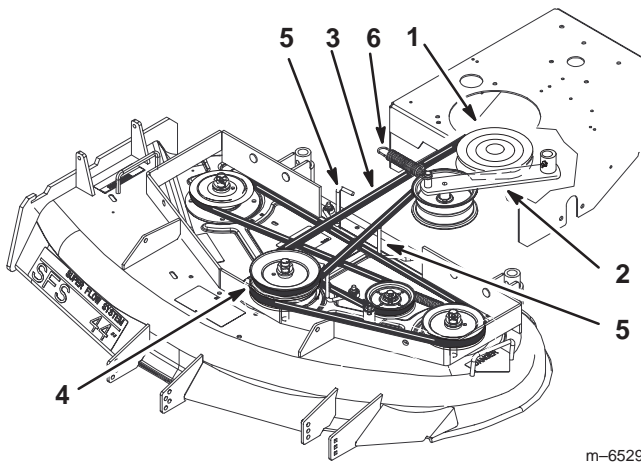

**Figure 60**

- |                          |                          |
|--------------------------|--------------------------|
| 1. PTO engagement pulley | 4. Center Spindle Pulley |
| 2. PTO drive belt idler  | 5. PTO Drive belt guide  |
| 3. PTO drive Belt        | 6. Idler Spring          |

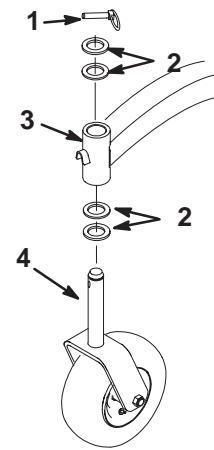

**Figure 61**

- |                                 |                                |
|---------------------------------|--------------------------------|
| 1. Locking Pin                  | 3. Carrier frame mounting tube |
| 2. Spacers (locate as required) | 4. Caster wheel fork           |

## Replacing the Caster Wheel Fork Bushings

The caster wheel forks are mounted in bushings pressed into the top and bottom of the carrier frame mounting tubes. To check the bushings, move the caster forks back and forth and side-to-side. If a caster fork is loose, the bushings are worn and must be replaced.

1. Raise the cutting unit so the caster wheels are off the floor, then block up the front of the mower with jack stands.
2. Remove the locking pin and spacer(s) from the top of the caster wheel fork (Fig. 61).
3. Pull the caster wheel fork out of the mounting tube, leaving the spacer(s) on the bottom of the fork. Remember the location of the spacers on each fork to ensure correct installation, and to maintain a level deck.

4. Insert a pin punch into the mounting tube and carefully drive out the bushings (Fig. 62). Clean the inside of the mounting tube.
5. Grease the inside and outside of the new bushings. Use a hammer and flat plate to carefully drive the bushings into the mounting tube.
6. Inspect the caster wheel fork for wear and replace if necessary (Fig. 61).
7. Slide the caster wheel fork through the bushings in the mounting tube. Replace the spacer(s) onto the fork and secure with the retaining ring (Fig 61).

**Important** The inside diameter of the bushings may collapse slightly when installed. If the caster wheel fork does not slide into the new bushings, ream both bushings to an inside diameter of 1.126 inch (29 mm).

8. Grease the fitting on the carrier frame mounting tube using No. 2 general purpose lithium base or molybdenum base grease.

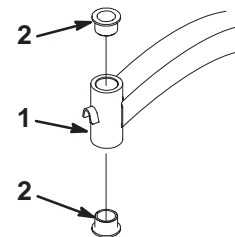

**Figure 62**

- |                  |            |
|------------------|------------|
| 1. Mounting Tube | 2. Bushing |
|------------------|------------|

## Caster Wheel and Bearings Service

The caster wheels rotate on a roller bearing supported by a spanner bushing. If the bearing is kept well lubricated, wear will be minimal. Failure to keep the bearing well lubricated will cause rapid wear. A wobbly caster wheel usually indicates a worn bearing.

1. Remove the locknut and wheel bolt holding the caster wheel to the caster fork (Fig. 63).
2. Remove one bushing, then pull the spanner bushing and roller bearing out of the wheel hub (Fig. 63).
3. Remove the other bushing from the wheel hub and clean any grease and dirt from the wheel hub (Fig. 63).
4. Inspect the roller bearing, bushings, spanner bushing and inside of the wheel hub for wear. Replace any defective or worn parts (Fig. 63).

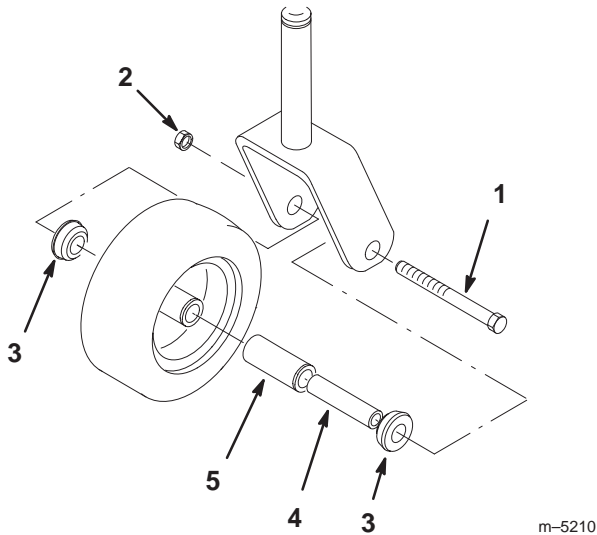

Figure 63

- |               |                    |
|---------------|--------------------|
| 1. Locknut    | 4. Spanner Bushing |
| 2. Wheel Bolt | 5. Roller Bearing  |
| 3. Bushing    |                    |

5. To assemble, place one bushing into the wheel hub. Grease the roller bearing and spanner bushing and slide them into the wheel hub. Place the second bushing into the wheel hub (Fig. 63).
6. Install the caster wheel into the caster fork and secure with the wheel bolt and locknut. Tighten the locknut until the spanner bushing bottoms against the inside of the caster forks (Fig. 63).
7. Grease the fitting on the caster wheel.

## Replacing the Grass Deflector



### Warning



**An uncovered discharge opening could allow the lawn mower to throw objects in the operator's or bystander's direction and result in serious injury. Also, contact with the blade could occur.**

**Never operate the lawn mower unless you install a cover plate, a mulch plate, or a grass chute and catcher.**

1. Remove the locknut, bolt, spring and spacer holding the deflector to the pivot brackets (Fig. 64). Remove damaged or worn grass deflector.
2. Place spacer and spring onto grass deflector. Place the L end of spring behind deck edge.

**Note:** Make sure the L end of spring is installed behind deck edge before installing the bolt as shown in figure 64.

3. Install bolt and nut. Place the J hook end of spring around grass deflector (Fig. 64).

**Important** The grass deflector must be able to lower down into position. Lift the deflector up to test that it lowers into the full down position.

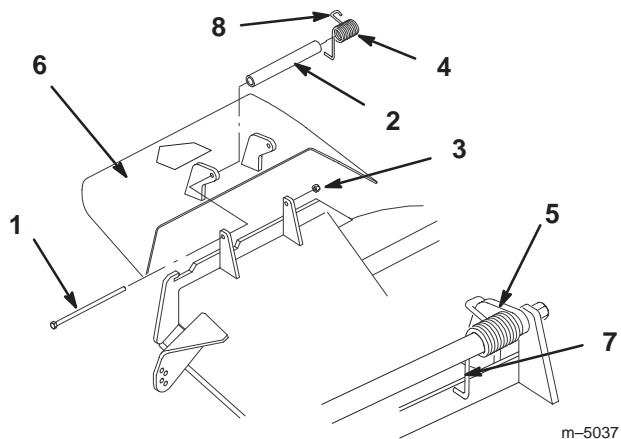
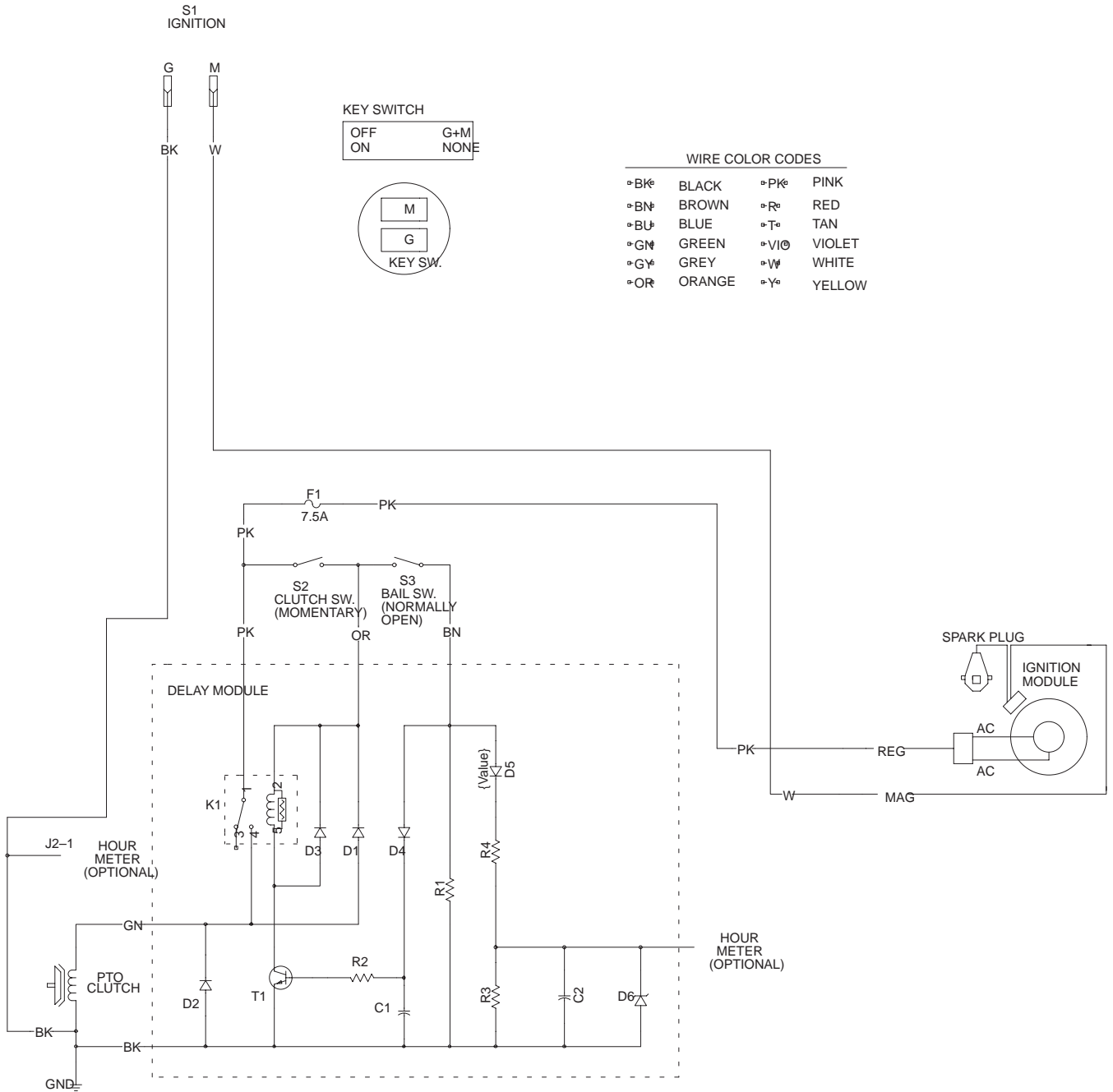

Figure 64

- |                     |   |
|---------------------|---|
| 1. Bolt             | 6. Grass Deflector  |
| 2. Spacer           | 7. L end of spring, place behind deck edge before installing bolt |
| 3. Locknut          | 8. J hook end of spring   |
| 4. Spring           |   |
| 5. Spring installed |   |

# Wiring Diagram



## Cleaning and Storage

1. Disengage the power take off (PTO), set the parking brake, and turn the ignition key to **off**. Remove the key.
2. Remove grass clippings, dirt, and grime from the external parts of the entire machine, especially the engine. Clean dirt and chaff from the outside of the engine's cylinder head fins and blower housing.

**Important** You can wash the machine with mild detergent and water. Do not pressure wash the machine. Avoid excessive use of water, especially near the shift lever plate, and engine.

3. Check the brake; refer to Brake Service, page 29.
4. Service the air cleaner; refer to Air Cleaner Service, page 25.
5. Grease the machine; refer to Greasing and Lubrication, page 28.
6. Change the crankcase oil; refer to Engine Oil Service, page 26.
7. Check the tire pressure; refer to Tire Pressure, page 29.
8. For long-term storage (more than 90 days) add stabilizer/conditioner additive to fuel in the tank.

- A. Run engine to distribute conditioned fuel through the fuel system (5 minutes).
- B. Stop engine, allow to cool and drain the fuel tank; refer to Fuel Tank, page 31, or operate engine until it stops.
- C. Restart engine and run until it stops. Repeat, on Choke until engine will not restart.
- D. Dispose of fuel properly. Recycle as per local codes.

**Note:** Do not store stabilizer/conditioned gasoline over 90 days.

9. Remove the spark plug(s) and check its condition; refer to Spark Plug Service, page 27. With the spark plug(s) removed from the engine, pour two tablespoons of engine oil into the spark plug hole. Now use the starter to crank the engine and distribute the oil inside the cylinder. Install the spark plug(s). Do not install the wire on the spark plug(s).
10. Check and tighten all bolts, nuts, and screws. Repair or replace any part that is damaged or defective.
11. Paint all scratched or bare metal surfaces. Paint is available from your Authorized Service Dealer.
12. Store the machine in a clean, dry garage or storage area. Remove the key from the ignition switch and keep it in a memorable place. Cover the machine to protect it and keep it clean.

## Troubleshooting

PROBLEM	POSSIBLE CAUSES	CORRECTIVE ACTION
Engine will not start, starts hard, or fails to keep running.	<ol style="list-style-type: none"> <li>1. Fuel tank is empty.</li> <li>2. Choke is not ON.</li> <li>3. Air cleaner is dirty.</li> <li>4. Spark plug wire is loose or disconnected.</li> <li>5. Spark plug is pitted, fouled, or gap is incorrect.</li> <li>6. Dirt in fuel filter.</li> <li>7. Dirt, water, or stale fuel is in fuel system.</li> <li>8. Shift lever plate out of adjustment.</li> </ol>	<ol style="list-style-type: none"> <li>1. Fill fuel tank with gasoline.</li> <li>2. Move throttle lever to choke position.</li> <li>3. Clean or replace air cleaner element.</li> <li>4. Install wire on spark plug.</li> <li>5. Install new, correctly gapped spark plug.</li> <li>6. Replace fuel filter.</li> <li>7. Contact Authorized Service Dealer.</li> <li>8. Adjust shift lever plate to match shift lever neutral position.</li> </ol>

<b>PROBLEM</b>	<b>POSSIBLE CAUSES</b>	<b>CORRECTIVE ACTION</b>
Engine loses power.	<ol style="list-style-type: none"> <li>1. Engine load is excessive.</li> <li>2. Air cleaner is dirty.</li> <li>3. Oil level in crankcase is low.</li> <li>4. Cooling fins and air passages under engine blower housing are plugged.</li> <li>5. Spark plug is pitted, fouled, or gap is incorrect.</li> <li>6. Vent hole in fuel cap is plugged.</li> <li>7. Dirt in fuel filter.</li> <li>8. Dirt, water, or stale fuel is in fuel system.</li> </ol>	<ol style="list-style-type: none"> <li>1. Reduce ground speed.</li> <li>2. Clean air cleaner element.</li> <li>3. Add oil to crankcase.</li> <li>4. Remove obstruction from cooling fins and air passages.</li> <li>5. Install new, correctly gapped spark plug.</li> <li>6. Clean or replace the fuel cap.</li> <li>7. Replace fuel filter.</li> <li>8. Contact Authorized Service Dealer.</li> </ol>
Engine overheats.	<ol style="list-style-type: none"> <li>1. Engine load is excessive.</li> <li>2. Oil level in crankcase is low.</li> <li>3. Cooling fins and air passages under engine blower housing are plugged.</li> </ol>	<ol style="list-style-type: none"> <li>1. Reduce ground speed.</li> <li>2. Add oil to crankcase.</li> <li>3. Remove obstruction from cooling fins and air passages.</li> </ol>
Machine does not drive.	<ol style="list-style-type: none"> <li>1. Shift lever is in NEUTRAL.</li> <li>2. Traction belt is worn, loose or broken.</li> <li>3. Traction belt is off pulley.</li> <li>4. Broken or missing idler spring.</li> </ol>	<ol style="list-style-type: none"> <li>1. Move shift lever to a drive gear position.</li> <li>2. Change Belt.</li> <li>3. Change Belt.</li> <li>4. Replace spring</li> </ol>
Abnormal vibration.	<ol style="list-style-type: none"> <li>1. Cutting blade(s) is/are bent or unbalanced.</li> <li>2. Blade mounting bolt is loose.</li> <li>3. Engine mounting bolts are loose.</li> <li>4. Loose engine pulley, idler pulley, or blade pulley.</li> <li>5. Engine pulley is damaged.</li> <li>6. Blade spindle bent.</li> </ol>	<ol style="list-style-type: none"> <li>1. Install new cutting blade(s).</li> <li>2. Tighten blade mounting bolt.</li> <li>3. Tighten engine mounting bolts.</li> <li>4. Tighten the appropriate pulley.</li> <li>5. Contact Authorized Service Dealer.</li> <li>6. Contact Authorized Service Dealer.</li> </ol>

PROBLEM	POSSIBLE CAUSES	CORRECTIVE ACTION
Uneven cutting height.	<ol style="list-style-type: none"> <li>1. Blade(s) not sharp.</li> <li>2. Cutting blade(s) is/are bent.</li> <li>3. Mower is not level.</li> <li>4. Underside of mower is dirty.</li> <li>5. Tire pressure is incorrect.</li> <li>6. Blade spindle bent.</li> </ol>	<ol style="list-style-type: none"> <li>1. Sharpen blade(s).</li> <li>2. Install new cutting blade(s).</li> <li>3. Level mower from side-to-side and front-to-rear.</li> <li>4. Clean the underside of the mower.</li> <li>5. Adjust tire pressure.</li> <li>6. Contact Authorized Service Dealer.</li> </ol>
Blades do not rotate.	<ol style="list-style-type: none"> <li>1. PTO Drive belt is worn, loose or broken.</li> <li>2. PTO Drive belt is off pulley.</li> <li>3. Deck belt is worn, loose or broken.</li> <li>4. Deck belt is off pulley.</li> <li>5. Broken or missing idler spring.</li> </ol>	<ol style="list-style-type: none"> <li>1. Install new drive belt.</li> <li>2. Install drive belt and check adjusting shafts and belt guides for correct position.</li> <li>3. Install new deck belt.</li> <li>4. Install deck pulley and check the idler pulley, idler arm and spring for correct position and function.</li> <li>5. Replace idler spring</li> </ol>









LCE

# The Toro Total Coverage Guarantee

## A Limited Warranty

### Conditions and Products Covered

The Toro Company and its affiliate, Toro Warranty Company, pursuant to an agreement between them, jointly promise to repair the listed Toro Products if defective in materials or workmanship. The following time periods apply from the date of purchase:

<u>Products</u>	<u>Warranty Period</u>
• All Products	1 year
• All Spindles	2 years parts and labor; third year, parts only
• Engines/Hydraulic Systems* on the following: Outfront and Mid-Mount Z's ProLine Mid-Size Mowers Groundsmaster® Riding Mowers Backpack Blowers	2 years
• Deck Shells (36"-72") on the following: ProLine Mid-Size Mowers Mid-Mount Z's	2 years
• Electric Clutch on 200 Series Mid-Mount Z's	2 years

This warranty includes the cost of parts and labor, but you must pay transportation costs.

This warranty applies to:

- Outfront and Mid-Mount Z's
- ProLine Mid-Size Mowers
- Groundsmaster Riding Mowers
- Turf Maintenance Equipment
- Debris Management Equipment

\* Some engines used on Toro LCE Products are warranted by the engine manufacturer.

### Instructions for Obtaining Warranty Service

If you think that your Toro Product contains a defect in materials or workmanship, follow this procedure:

1. Contact any Toro Authorized or Master Service Dealer to arrange service at their dealership. To locate a dealer convenient to you, access our website at [www.Toro.com](http://www.Toro.com). U.S. Customers may also call 800-348-2424.
2. Bring the product and your proof of purchase (sales receipt) to the Service Dealer.

If for any reason you are dissatisfied with the Service Dealer's analysis or with the assistance provided, contact us at:

LCB Customer Service Department  
Toro Warranty Company  
8111 Lyndale Avenue South  
Bloomington, MN 55420-1196  
888-577-7466 (U.S. customers)  
877-484-9255 (Canada customers)

### Countries Other than the United States or Canada

Customers who have purchased Toro products exported from the United States or Canada should contact their Toro Distributor (Dealer) to obtain guarantee policies for your country, province, or state. If for any reason you are dissatisfied with your Distributor's service or have difficulty obtaining guarantee information, contact the Toro importer. If all other remedies fail, you may contact us at Toro Warranty Company.

### Owner Responsibilities

You must maintain your Toro Product by following the maintenance procedures described in the operator's manual. Such routine maintenance, whether performed by a dealer or by you, is at your expense.

### Items and Conditions Not Covered

There is no other express warranty except for special emission system coverage on some products. This express warranty does not cover the following:

- Cost of regular maintenance service or parts, such as filters, fuel, lubricants, tune-up parts, blade sharpening, brake and clutch adjustments.
- Any product or part which has been altered or misused or required replacement or repair due to normal wear, accidents, or lack of proper maintenance.
- Repairs necessary due to improper fuel, contaminants in the fuel system, or failure to properly prepare the fuel system prior to any period of non-use over three months.
- Pickup and delivery charges.

All repairs covered by this warranty must be performed by an Authorized Toro Service Dealer using Toro approved replacement parts.

### General Conditions

Repair by an Authorized Toro Service Dealer is your sole remedy under this warranty.

Neither The Toro Company nor Toro Warranty Company is liable for indirect, incidental or consequential damages in connection with the use of the Toro Products covered by this warranty, including any cost or expense of providing substitute equipment or service during reasonable periods of malfunction or non-use pending completion of repairs under this warranty.

Some states do not allow exclusions of incidental or consequential damages, or limitations on how long an implied warranty lasts, so the above exclusions and limitations may not apply to you.

All implied warranties of merchantability (that the product is fit for ordinary use) and fitness for use (that the product is fit for a particular purpose) are limited to the duration of the express warranty.

This warranty gives you specific legal rights, and you may also have other rights which vary from state to state.