



## **Mid-Size Mower**

### **Proline Gear 14hp with 48" Side Discharge Mower**

**Model No. 30196—Serial No. 220000001 and Up**

**Operator's Manual**



## Warning



**The engine exhaust from this product contains chemicals known to the State of California to cause cancer, birth defects, or other reproductive harm.**

**Important** This engine is not equipped with a spark arrester muffler. It is a violation of California Public Resource Code Section 4442 to use or operate this engine on any forest-covered, brush-covered or grass-covered land. Other states or federal areas may have similar laws.

This spark ignition system complies with Canadian ICES-002.

Ce système d'allumage par étincelle de véhicule est conforme à la norme NMB-002 du Canada.

**The enclosed Engine Owner's Manual is supplied for information regarding The U.S. Environmental Protection Agency (EPA) and the California Emission Control Regulation of emission systems, maintenance and warranty.**

**Keep this engine Owner's Manual with your unit. Should this engine Owner's Manual become damaged or illegible, replace immediately. Replacements may be ordered through the engine manufacturer.**

# Contents

	Page
Introduction .....	2
Safety .....	3
Safe Operating Practices .....	3
Toro Mower Safety .....	4
Slope Chart .....	7
Safety and Instruction Decals .....	9
Gasoline and Oil .....	12
Recommended Gasoline .....	12
Using Stabilizer/Conditioner .....	12
Filling the Fuel Tank .....	12
Checking the Engine Oil Level .....	12
Setup .....	13
Loose Parts .....	13
Installing the Front Casters .....	14
Installing the Upper Handle and Wire Harness .....	14
Installing the Traction Control Rods .....	15
Connecting the Throttle Cable .....	15
Installing the Blade Control (PTO) Rod .....	16
Installing the Shift Lever .....	16
Mounting the Fuel Tank .....	16
Operation .....	17

	Page
Think Safety First .....	17
Controls .....	17
Operating the Parking Brake .....	18
Starting and Stopping the Engine .....	18
Operating the Blade Control (PTO) .....	19
The Safety Interlock System .....	19
Driving Forward or Backward .....	20
Operating the Lower Control Bar .....	20
Stopping the Machine .....	21
Using Side Discharge or Mulch Grass .....	21
Adjusting Height-of-Cut .....	21
Height-of-Cut Chart .....	23
Maintenance .....	24
Recommended Maintenance Schedule .....	24
Servicing the Air Cleaner .....	25
Servicing the Engine Oil .....	26
Servicing the Spark Plug .....	27
Servicing the Cutting Blades .....	28
Checking the Tire Pressure .....	29
Cleaning the Cooling System .....	30
Greasing and Lubrication .....	30
Servicing the Brakes .....	31
Servicing the Fuel Tank .....	31
Servicing the Fuel Filter .....	32
Replacing the Wheel Belt .....	32
Replacing the Traction Belt .....	33
Replacing the Mower Belt .....	33
Adjusting the Mower Belt Tension .....	34
Adjusting the Blade Brake .....	34
Adjusting the Grass/Mud Scraper .....	35
Replacing the Grass Deflector .....	35
Wiring Diagram .....	36
Cleaning and Storage .....	36
Troubleshooting .....	37
The Toro Total Coverage Guarantee .....	40

# Introduction

Read this manual carefully to learn how to operate and maintain your product properly. The information in this manual can help you and others avoid injury and product damage. Although Toro designs and produces safe products, you are responsible for operating the product properly and safely.

Whenever you need service, genuine Toro parts, or additional information, contact an Authorized Service Dealer or Toro Customer Service and have the model and serial numbers of your product ready. Figure 1 illustrates the location of the model and serial numbers on the product.

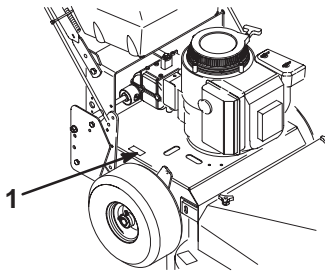

m-3775

**Figure 1**

1. Location of the model and serial numbers

Write the product model and serial numbers in the space below:

<p><b>Model No.</b> _____</p> <p><b>Serial No.</b> _____</p>
--

This manual identifies potential hazards and has special safety messages that help you and others avoid personal injury and even death. **Danger**, **Warning**, and **Caution** are signal words used to identify the level of hazard. However, regardless of the hazard, be extremely careful.

**Danger** signals an extreme hazard that *will* cause serious injury or death if you do not follow the recommended precautions.

**Warning** signals a hazard that *may* cause serious injury or death if you do not follow the recommended precautions.

**Caution** signals a hazard that may cause minor or moderate injury if you do not follow the recommended precautions.

This manual uses two other words to highlight information.

**Important** calls attention to special mechanical information and **Note**: emphasizes general information worthy of special attention.

## Safety

**This machine meets or exceeds the B71.4 1999 specifications of the American National Standards Institute, in effect at time of production.**

**Note:** The addition of attachments made by other manufacturers that do not meet American National Standards Institute certification will cause noncompliance of this machine.

**Improper use or maintenance by the operator or owner can result in injury. To reduce the potential for injury, comply with these safety instructions and always pay attention to the safety alert symbol, which means**

**CAUTION, WARNING, or DANGER—“personal safety instruction.” Failure to comply with the instruction may result in personal injury or death.**

## Safe Operating Practices

The following instructions are from ANSI standard B71.4—1999.

### Training

- Read the Operator’s Manual and other training material. If the operator(s) or mechanic(s) can not read English it is the owner’s responsibility to explain this material to them.
- Become familiar with the safe operation of the equipment, operator controls, and safety signs.
- All operators and mechanics should be trained. The owner is responsible for training the users.
- Never let children or untrained people operate or service the equipment. Local regulations may restrict the age of the operator.
- The owner/user can prevent and is responsible for accidents or injuries occurring to himself or herself, other people or property.

### Preparation

- Evaluate the terrain to determine what accessories and attachments are needed to properly and safely perform the job. Only use accessories and attachments approved by the manufacturer.
- Wear appropriate clothing including hard hat, safety glasses and ear protection. Long hair, loose clothing or jewelry may get tangled in moving parts.
- Inspect the area where the equipment is to be used and remove all objects such as rocks, toys and wire which can be thrown by the machine.
- Use extra care when handling gasoline and other fuels. They are flammable and vapors are explosive.
  - Use only an approved container
  - Never remove gas cap or add fuel with engine running. Allow engine to cool before refueling. Do not smoke.
  - Never refuel or drain the machine indoors.
- Check that operator’s presence controls, safety switches and shields are attached and functioning properly. Do not operate unless they are functioning properly.

## Operation

- Never run an engine in an enclosed area.
- Only operate in good light, keeping away from holes and hidden hazards.
- Be sure all drives are in neutral and parking brake is engaged before starting engine.
- Slow down and use extra care on hillsides. Be sure to travel side-to-side on hillsides. Turf conditions can affect the machine's stability. Use caution while operating near drop-offs.
- Slow down and use caution when making turns and when changing directions on slopes.
- Never raise deck with the blades running.
- Never operate with the PTO shield, or other guards not securely in place. Be sure all interlocks are attached, adjusted properly, and functioning properly.
- Never operate with the discharge deflector raised, removed or altered, unless using a grass catcher.
- Do not change the engine governor setting or overspeed the engine.
- Stop on level ground, disengage drives, engage parking brake (if provided), shut off engine before leaving the operator's position for any reason including emptying the catchers or unclogging the chute.
- Stop equipment and inspect blades after striking objects or if an abnormal vibration occurs. Make necessary repairs before resuming operations.
- Keep hands and feet away from the cutting unit.
- Look behind and down before backing up to be sure of a clear path.
- Keep pets and bystanders away.
- Slow down and use caution when making turns and crossing roads and sidewalks. Stop blades if not mowing.
- Be aware of the mower discharge direction and do not point it at anyone.
- Do not operate the mower under the influence of alcohol or drugs
- Use care when loading or unloading the machine into or from a trailer or truck
- Use care when approaching blind corners, shrubs, trees, or other objects that may obscure vision.
- Clean grass and debris from cutting unit, drives, mufflers, and engine to help prevent fires. Clean up oil or fuel spillage.
- Let engine cool before storing and do not store near flame.
- Shut off fuel while storing or transporting. Do not store fuel near flames or drain indoors.
- Park machine on level ground. Set parking brake. Never allow untrained personnel to service machine.
- Use jack stands to support components when required.
- Carefully release pressure from components with stored energy.
- Use care when checking blades. Wrap the blade(s) or wear gloves, and use caution when servicing them. Only replace blades. Never straighten or weld them.
- Keep hands and feet away from moving parts. If possible, do not make adjustments with the engine running.
- Keep all parts in good working condition and all hardware tightened. Replace all worn or damaged decals.

## Maintenance and storage

- Disengage drives, set parking brake, stop engine and disconnect spark plug wire. Wait for all movement to stop before adjusting, cleaning or repairing.

## Toro Mower Safety

The following list contains safety information specific to Toro products and other safety information you must know.

This product is capable of amputating hands and feet and throwing objects. Always follow all safety instructions to avoid serious injury or death.

This product is designed for cutting and recycling grass or, when equipped with a grass bagger, for catching cut grass. Any use for purposes other than these could prove dangerous to user and bystanders.

## General Operation

- Allow only responsible adults who are familiar with the instructions to operate the machine.
- Be sure the area is clear of other people before mowing. Stop the machine if anyone enters the area.
- Do not mow in reverse unless absolutely necessary. Always look down and behind before and while backing.
- Be aware of the mower discharge direction and do not point it at anyone. Do not operate the mower without either the entire grass catcher or the guard in place.
- Slow down before turning. Sharp turns on any terrain may cause loss of control.

- Turn off blades when not mowing.
- Keep hands, feet, hair and loose clothing away from attachment discharge area, underside of mower and any moving parts while engine is running.
- Stop the engine before removing the grass catcher or unclogging the chute.
- Mow only in daylight or good artificial light.
- Watch for traffic when operating near or crossing roadways.
- Do not touch equipment or attachment parts which may be hot from operation. Allow to cool before attempting to maintain, adjust or service.
- Use only Toro-approved attachments. Warranty may be voided if used with unapproved attachments.

## Slope Operation

All slopes and ramps require extra caution. If you feel uneasy on a slope, do not mow it.

### DO

- Remove obstacles such as rocks, tree limbs, etc. from the mowing area. Watch for holes, ruts or bumps. Tall grass can hide obstacles.
- Use slow speed so that you will not have to stop while on the slope.
- Use extra care with grass catchers or other attachments. These can change the stability of the machine.
- Keep all movement on slopes slow and gradual. Do not make sudden changes in speed or direction.
- Avoid starting or stopping on a slope. If tires lose traction, disengage the blades.
- Check carefully for overhead clearances (i.e. branches, doorways, electrical wires) before driving under any objects and do not contact them.
- Mow slopes side-to-side.

### DO NOT

- Do not mow slopes greater than 15 degrees.
- Avoid turning on slopes. If you must turn, turn slowly and gradually downhill, if possible.
- Do not mow near drop-offs, ditches, or embankments. The machine could suddenly turn over if a wheel goes over the edge of a cliff or ditch, or if an edge caves in.
- Do not mow on wet grass. Reduced traction could cause sliding.
- Do not use a grass catcher on steep slopes. Heavy grass bags could cause loss of control of the machine.
- Do not mow up and down slopes.

## Service

- Never store the machine or fuel container inside where there is an open flame, such as near a water heater or furnace.
- Keep nuts and bolts tight, especially the blade attachment bolts. Keep equipment in good condition.
- Never tamper with safety devices. Check safety systems for proper operation before each use.
- Use only genuine replacement parts to ensure that original standards are maintained.
- Check brake operation frequently. Adjust and service as required.



# Slope Chart





# Safety and Instruction Decals



Safety decals and instructions are easily visible to the operator and are located near any area of potential danger. Replace any decal that is damaged or lost.



82-2280



43-8480

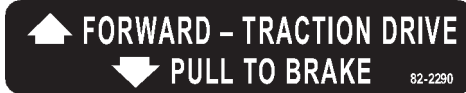

82-2290



54-9220



66-1340



67-5360

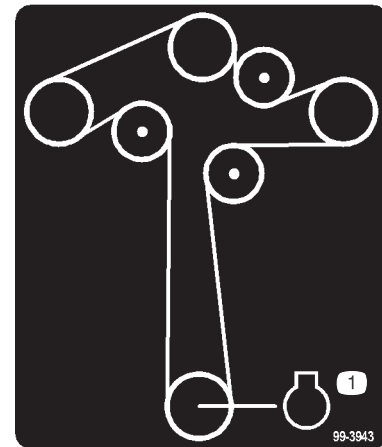

99-3943



63-8440

1. Hot surface

1. Engine



95-2814



98-4387

1. Warning—wear hearing protection.



95-5537

1. Read the *Operator's Manual* for instructions on operating the cutting blade
2. Push forward to engage
3. Pull back to disengage

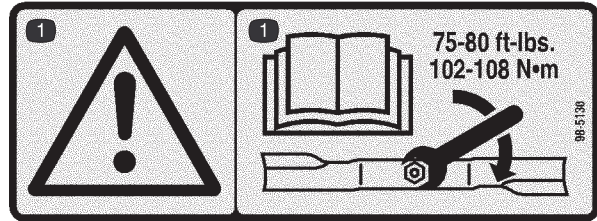

98-5130

1. Warning—read the *Operator's Manual* for instructions on torquing the blade bolt/nut to 75–80 ft.-lb.(102–106 N·m).



98-3256



98-0776



98-3266



95-5437

**ProLine**

**TORO**

# Gasoline and Oil

## Recommended Gasoline

Use UNLEADED Regular Gasoline suitable for automotive use (85 pump octane minimum). Leaded regular gasoline may be used if unleaded regular is not available.

**Important** Never use methanol, gasoline containing methanol, or gasohol containing more than 10% ethanol because the fuel system could be damaged. Do not mix oil with gasoline.



### Danger



In certain conditions, gasoline is extremely flammable and highly explosive. A fire or explosion from gasoline can burn you and others and can damage property.

- Fill the fuel tank outdoors, in an open area, when the engine is cold. Wipe up any gasoline that spills.
- Never fill the fuel tank inside an enclosed trailer.
- Do not fill the fuel tank completely full. Add gasoline to the fuel tank until the level is 1/4 to 1/2 in. (6 to 13 mm) below the bottom of the filler neck. This empty space in the tank allows gasoline to expand.
- Never smoke when handling gasoline, and stay away from an open flame or where gasoline fumes may be ignited by a spark.
- Store gasoline in an approved container and keep it out of the reach of children. Never buy more than a 30-day supply of gasoline.
- Always place gasoline containers on the ground away from your vehicle before filling.
- Do not fill gasoline containers inside a vehicle or on a truck or trailer bed because interior carpets or plastic truck bed liners may insulate the container and slow the loss of any static charge.
- When practical, remove gas-powered equipment from the truck or trailer and refuel the equipment with its wheels on the ground.
- If this is not possible, then refuel such equipment on a truck or trailer from a portable container, rather than from a gasoline dispenser nozzle.
- If a gasoline dispenser nozzle must be used, keep the nozzle in contact with the rim of the fuel tank or container opening at all times until fueling is complete.



### Warning



Gasoline is harmful or fatal if swallowed. Long-term exposure to vapors can cause serious injury and illness.

- Avoid prolonged breathing of vapors.
- Keep face away from nozzle and gas tank or conditioner opening.
- Keep gas away from eyes and skin.

## Using Stabilizer/Conditioner

Use a fuel stabilizer/conditioner in the machine to provide the following benefits:

- Keeps gasoline fresh during storage of 90 days or less. For longer storage it is recommended that the fuel tank be drained.
- Cleans the engine while it runs
- Eliminates gum-like varnish buildup in the fuel system, which causes hard starting

**Important** Do not use fuel additives containing methanol or ethanol.

Add the correct amount of gas stabilizer/conditioner to the gas.

**Note:** A fuel stabilizer/conditioner is most effective when mixed with fresh gasoline. To minimize the chance of varnish deposits in the fuel system, use fuel stabilizer at all times.

## Filling the Fuel Tank

1. Shut the engine off and set the parking brake.
2. Clean around the fuel tank cap and remove the cap. Add unleaded regular gasoline to both fuel tanks, until the level is 1/4 to 1/2 inch (6 mm to 13 mm) below the bottom of the filler neck. This space in the tank allows gasoline to expand. Do not fill the fuel tank completely full.
3. Install fuel tank cap securely. Wipe up any gasoline that may have spilled.

## Checking the Engine Oil Level

Before you start the engine and use the machine, check the oil level in the engine crankcase; refer to Checking the Engine Oil Level, page 27.

# Setup

**Note:** Determine the left and right sides of the machine from the normal operating position.

## Loose Parts

**Note:** Use the chart below to verify all parts have been shipped.

DESCRIPTION	QTY.	USE
Caster assemblies	2	Installing the front casters
Bolt, 3/8 x 3/4 in.	8	
Flange nut, 3/8 in.	8	
Upper handle	1	Installing the upper handle and wire harness
Bolt, 3/8 x 1 in.	4	
Locknut, 3/8 in.	4	
Plastic terminal	1	
Wire tie	1	
Rod fitting	2	Installing the traction control rods
Clevis pin	2	
Washer, 1/4 in.	2	
Hairpin cotter	4	
PTO rod	1	Installing the PTO rod
Hairpin cotter	2	
Shift lever	1	Installing the shift lever
Rubber seal	1	
Square hole washer	1	
Spring washer	1	
Locknut	1	
Fuel tank	1	Installing the fuel tank
Bolt, 5/16 x 7/8 in.	2	
Lock washer, 5/16 in.	2	
Washer, 5/16 in.	4	
Stud	2	
Spring	2	
Hose clamp	1	
Operator's Manual	1	Read before operating machine
Engine Operator's Manual	1	Fill out and return to Toro
Parts Catalog	1	
Registration card	1	

## Installing the Front Casters

1. Align casters with holes on top and front of mower and insert 8 bolts (3/8 x 3/4 in.) through mower. Secure with 8 flange nuts (3/8 in.) below mower (Fig. 2).

**Note:** Tighten lower bolts first to pull caster against front, then top bolts last.

2. Torque bolts to 30–35 ft. lb. (40–47 N•m).

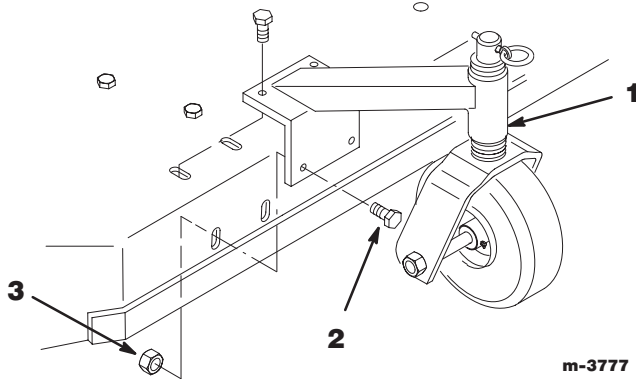
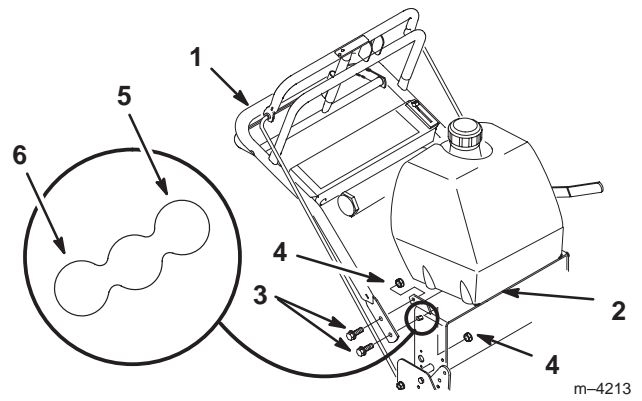

**Figure 2**

1. Front caster
2. Bolt, 3/8 x 3/4 in.
3. Flange nut, 3/8 in.

## Installing the Upper Handle and Wire Harness

1. Position handle outside frame and align upper handle mounting holes with desired mounting holes in rear frame. Select high, medium or low according to operators height (Fig. 3).
2. Secure each side with 2 bolts (3/8 x 1 in.) and 2 locknuts (3/8 in.) (Fig. 3).
3. Torque bolts to 25 ft. lbs. (34 N•m).



**Figure 3**

1. Upper handle
2. Rear frame
3. Bolt, 3/8 x 1 in.
4. Locknut, 3/8 in.
5. Low
6. High

4. Route wire harness inside of frame, along left handle and over throttle cable. Compress wire harness covering and press into lower and upper holes in rear of control panel (Fig. 4).
5. Thread harness up through rear tube of traction handle (Fig. 4).

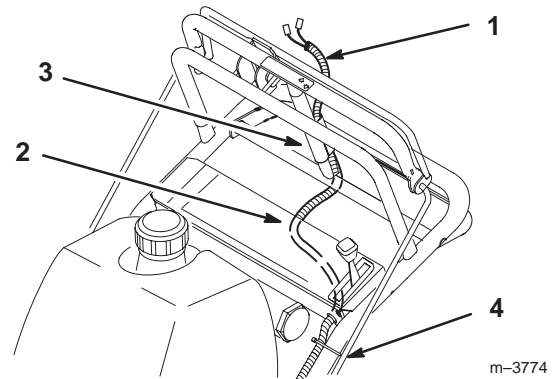

**Figure 4**

1. Wire harness
2. Control panel
3. Rear tube
4. Wire tie

6. Insert terminals into plastic plug until the clips snap into position (Fig. 5). If they do not snap, turn the plastic plug around and try again.
7. Push plug onto switch until it latches (Fig. 5).
8. Secure wire harness and throttle cable to left handle, away from PTO lever, with wire tie (Fig. 4).

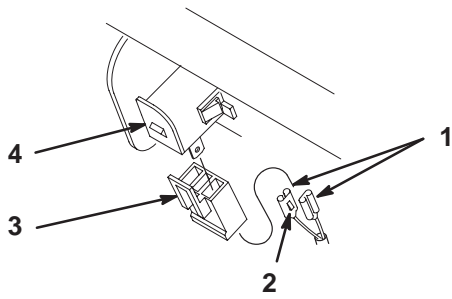

**Figure 5**

m-3782

- |             |                 |
|-------------|-----------------|
| 1. Terminal | 3. Plastic plug |
| 2. Clip     | 4. Switch       |

## Installing the Traction Control Rods

1. Thread trunnions equal distance onto each control rod. For a starting point, thread on approximately 2 in. (51 mm) (Fig. 6).
2. With trunnion rod up, slide clevis pins through rod fittings and mounting holes in idler brackets (from outside) (Fig. 6). Secure with washers (1/4 in.) and hairpin cotters (Fig. 6).

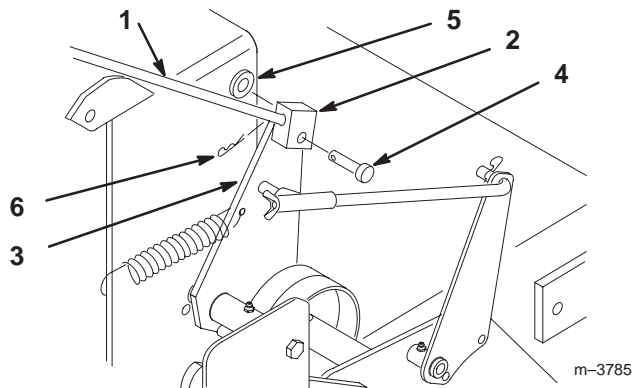

**Figure 6**

m-3785

- |                  |                    |
|------------------|--------------------|
| 1. Control rod   | 4. Clevis pin      |
| 2. Trunnion      | 5. Washer, 1/4 in. |
| 3. Idler bracket | 6. Hairpin cotter  |

3. Check the gap between upper control bar and fixed bar with wheel drive fully engaged. Gap should be approximately 1 to 1-1/4 in. (25–32 mm) (Fig. 7).

**Note:** The upper control bar and fixed bar must be parallel in the engaged, relaxed and brake positions.

4. Check operation. If adjustment is required, remove hairpin cotter securing rod to upper control bar. Thread rod in or out of trunion for proper position and install into upper control bar with hairpin cotter.

5. After adjusting control rods, check parking brake adjustment; refer to Servicing the Brake, page 30.

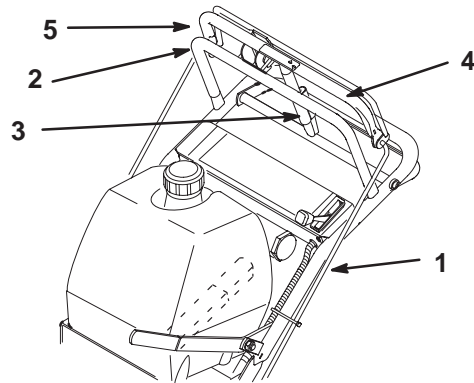

**Figure 7**

m-3770

- |                        |                                  |
|------------------------|----------------------------------|
| 1. Control rod         | 4. Upper control bar             |
| 2. Fixed control bar   | 5. 1 to 1-1/4 in. (25–32 mm) gap |
| 3. Parking brake lever |                                  |

## Connecting the Throttle Cable

1. Place throttle control lever in fast position.(Fig. 8).
2. Hook wire Z-bend into hole of speed control lever (Fig. 8).
3. Loosen cable clamp screw allowing cable installation, but do not tighten (Fig. 8).
4. Move control cable casing and wire until hole in speed control lever is aligned with hole in base plate. Insert a 1/4 in. (6 mm) diameter pin or bolt into aligned holes.
5. Pull throttle cable slightly to remove any slack and tighten cable clamp screw to lock adjustment in place.
6. Remove alignment pin and check control operation.

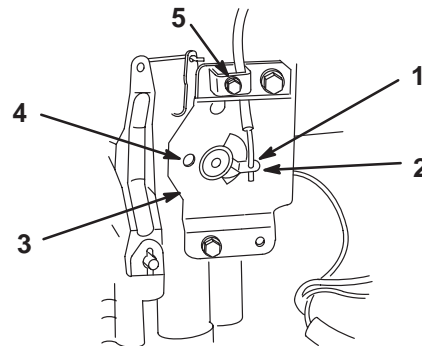

**Figure 8**

m-3787

- |                        |                                    |
|------------------------|------------------------------------|
| 1. Wire Z-bend         | 4. Alignment holes, 1/4 in. (6 mm) |
| 2. Speed control lever | 5. Cable clamp                     |
| 3. Base plate          |                                    |

## Installing the Blade Control (PTO) Rod

1. Rotate blade control lever (PTO) vertical away from left handle so rod drops down.
2. Remove hairpin cotters from bottom end of blade control rod (PTO) (Fig. 9).
3. Secure blade control (PTO) rod through hole in bellcrank with hairpin cotters (Fig. 9).

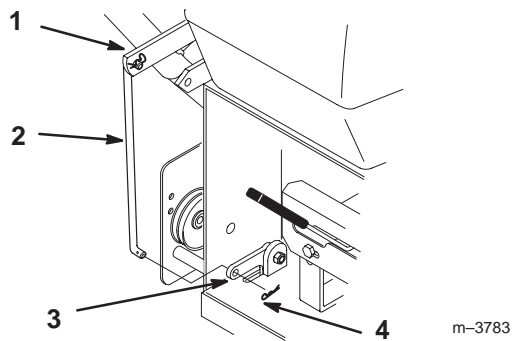

**Figure 9**

- |                        |                   |
|------------------------|-------------------|
| 1. Blade control lever | 3. Bellcrank      |
| 2. Blade control rod   | 4. Hairpin cotter |

## Installing the Shift Lever

1. Remove the locknut (3/8 in.) and spring disk washer from the stud on top of the transmission.

**Note:** Do not remove rubber seal washer and square hole washer from transmission shaft.

2. Slide shift lever through control panel and align mounting hole in lever with square on transmission shaft. Secure lever to transmission with previously removed spring washer and locknut (Fig. 10).
3. Replace the spring washer, dish down and locknut (Fig. 8).
4. Torque nut to 35 ft. lbs. (47 N•m).
5. Shift lever to second gear and check alignment of lever in slot of shifter plate. Clearance between top of lever and the top of the slot should be about equal to the clearance between bottom of the lever and the bottom of the slot.
6. If clearance is not correct, remove lever and bend it slightly to adjust.

**Note:** Do not bend lever while attached to transmission shaft or damage may occur.

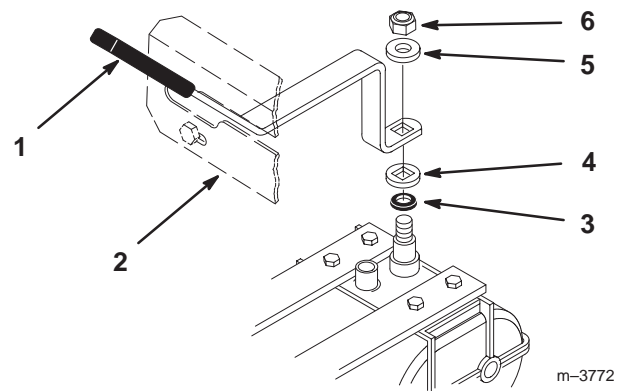

**Figure 10**

- |                       |                       |
|-----------------------|-----------------------|
| 1. Shift lever        | 4. Square hole washer |
| 2. Control panel      | 5. Spring washer      |
| 3. Rubber seal washer | 6. Locknut 3/8        |

## Mounting the Fuel Tank

1. Align fuel tank to top of rear frame and secure fuel tank right side with 2 bolts (5/16 x 7/8 in.), 2 lock washers (5/16 in.) and 2 washers (5/16 in.) (Fig. 11).
2. Secure fuel tank left side to frame with 2 studs (5/16 x 7/8 in.), 2 washers (5/16 in.) and 2 locknuts (5/16 in.) (Fig. 11).

**Note:** Tighten left side of control panel until it is completely tight and then unscrew locknut one full turn. This will allow the spring to work.

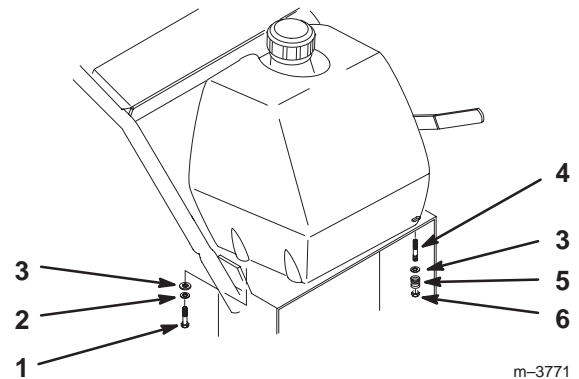

**Figure 11**

- |                          |            |
|--------------------------|------------|
| 1. Bolt, 5/8 x 7/8 in.   | 4. Stud    |
| 2. Lock washer, 5/16 in. | 5. Spring  |
| 3. Washer, 5/16 in.      | 6. Locknut |

3. Push fuel line onto fuel tank fitting and secure with hose clamp (Fig. 12).

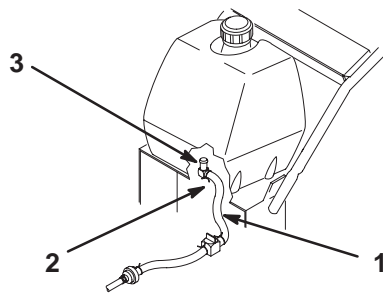

**Figure 12**

- 1. Fuel line
- 2. Hose clamp
- 3. Fuel fitting

m-3778

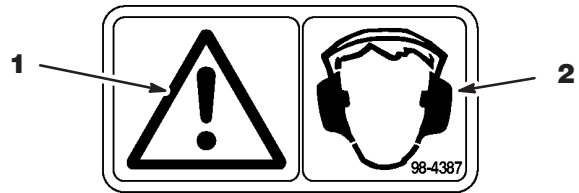

**Figure 13**

- 1. Caution
- 2. Wear hearing protection

## Operation

**Note:** Determine the left and right sides of the machine from the normal operating position.

### Think Safety First

Carefully read all the safety instructions and decals in the safety section. Knowing this information could help you, your family, pets or bystanders avoid injury.

The use of protective equipment for eyes, hearing, feet and head is recommended.

⚠
Caution
⚠

**This machine produces sound levels in excess of 85dBA at the operator's ear and can cause hearing loss through extended periods of exposure.**

**Wear hearing protection when operating this machine.**

## Controls

Become familiar with all the controls (Fig. 14) before you start the engine and operate the machine.

**Throttle Control** – The throttle control has Choke, Fast, Slow and Stop positions.

**Bail** – The bail, in conjunction with the PTO switch, allows the engine to be started with the PTO disengaged. With the bail compressed the blade control (PTO) can be engaged. Release the bail with the PTO engaged and the engine stops.

**Blade Control (PTO)** – The blade control lever (PTO) engages and disengages power to the mower blades. Move the PTO lever forward to engage the blades. Pull rearward to stop driving mower blades

**Gear Shift Lever** – Transmission has five forward speeds, neutral and reverse, and has an in-line shift pattern. Do not shift while unit is moving, as transmission damage may occur.

**Upper Control Bar** – Shift to desired gear and push forward on control bar to engage forward traction operation and pull back to brake. Pull right side of control bar to turn right and left side to turn left.

**Lower Control Bar** – Shift transmission to reverse and pull rearward on lower control bar to engage rearward traction operation.

**Parking Brake Lever** – Pull back on upper control bar and swing brake lever up against the upper handle to keep brake engaged.

**Recoil Starter** – Pull recoil starter handle to start engine.

**Fuel Shut-off Valve** – (In fuel line) Close fuel shut-off valve when transporting or storing mower.

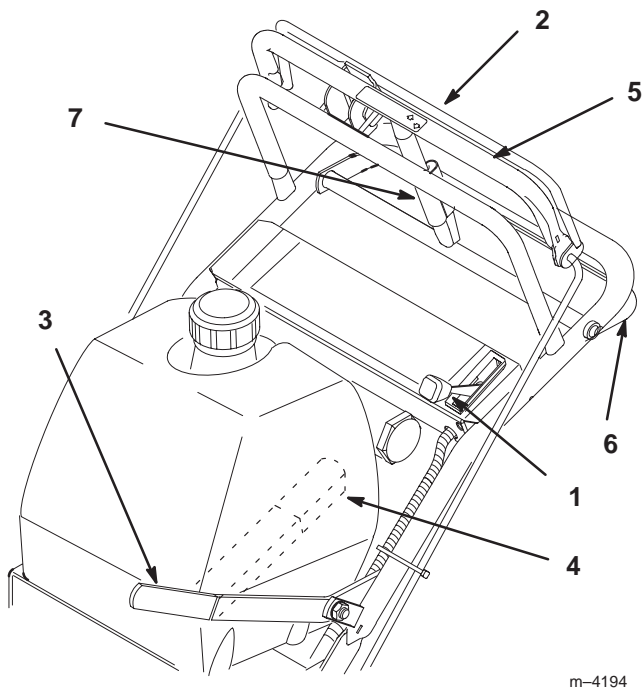

Figure 14

- |                        |                        |
|------------------------|------------------------|
| 1. Throttle control    | 5. Upper control bar   |
| 2. Bail                | 6. Lower control bar   |
| 3. Blade control (PTO) | 7. Parking brake lever |
| 4. Gear shift lever    |                        |

## Operating the Parking Brake

Always set the parking brake when you stop the machine or leave it unattended.

### Setting the Parking Brake

1. Pull the upper control bar rearward and hold it in this position (Fig. 15).
2. Lift the parking brake lock up and gradually release the upper control bar (Fig. 15). The brake lock should stay in the set (locked) position.

### Releasing the Parking Brake

1. Pull rearward on the upper control bar (Fig. 15). Lower the parking brake lock to the released position.

2. Gradually release the upper control bar.

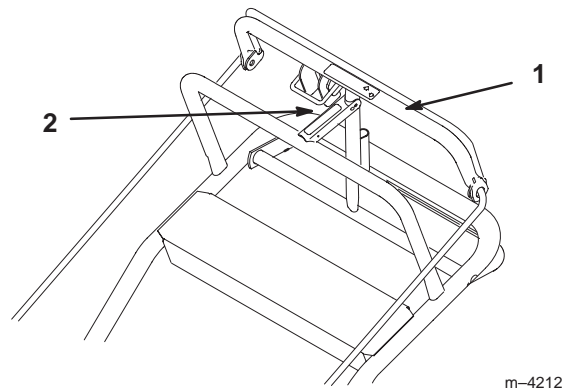

Figure 15

- |                      |                       |
|----------------------|-----------------------|
| 1. Upper control bar | 2. Parking brake lock |
|----------------------|-----------------------|

## Starting and Stopping the Engine

### Starting the Engine

1. Make sure spark plug wire(s) are installed on spark plug(s) and fuel valve is open.
2. Move the blade control to off, the shift lever to neutral and set the parking.
3. Move the throttle control to choke position before starting a cold engine.

**Note:** A warm or hot engine usually does not require any choking. To start a warm engine, move throttle control to fast position.

4. Grasp recoil starter handle firmly and pull out until positive engagement results; then pull handle vigorously to start engine. Allow rope to recoil slowly.

**Important** Do not pull recoil rope to its limit or let go of the starter handle when rope is pulled out because rope may break or recoil assembly may be damaged.

### Stopping the Engine

1. Move the throttle lever to slow (Fig. 16).

**Note:** If the engine has been working hard or is hot, let it idle for a minute before stopping. This helps cool the engine. In an emergency, the engine may be stopped by pulling the throttle all the way back, to stop.

2. To stop the engine pull the throttle all the way back, to stop (Fig. 16).

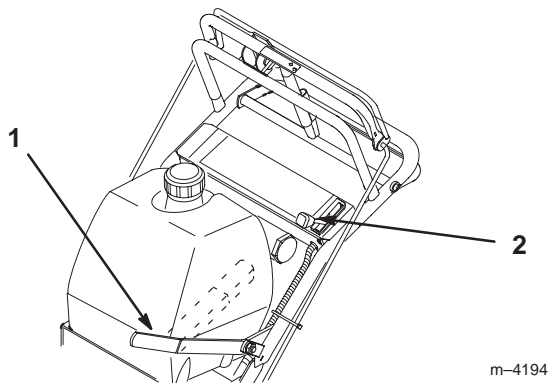

**Figure 16**

1. Blade control (PTO)      2. Throttle lever

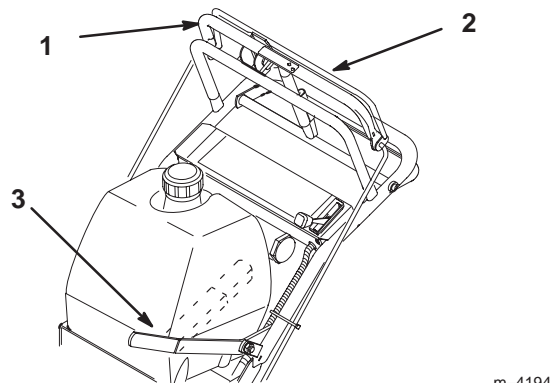

**Figure 17**

1. Upper control bar      3. Blade control (PTO)  
2. Bail

3. Set the parking brake.
4. Pull wire off spark plug(s) to prevent possibility of someone accidentally starting the machine while transporting or storing machine.
5. Close the fuel shut off valve before transporting or storing machine.

**Important** Make sure the fuel shut off valve is closed before transporting or storing machine, or fuel leakage may occur.

## Operating the Blade Control (PTO)

The blade control (PTO) lever engages and disengages power to the mower blades.

### Engaging the Mower Blades (PTO)

1. Pull on the upper control bar to stop the machine (Fig. 17).
2. Hold the bail against the upper control bar (Fig. 17).
3. To engage blade(s), push the blade control lever firmly forward, until it latches over-center (Fig. 17).

## Disengaging the Mower Blades (PTO)

1. To disengage the blade(s), pull blade control lever rearward, all the way (Fig. 17).

**Note:** It is necessary to fully and manually disengage mower.

## The Safety Interlock System

### Understanding the Safety Interlock System

	Caution	
<p><b>If safety interlock switches are disconnected or damaged the machine could operate unexpectedly causing personal injury.</b></p> <ul style="list-style-type: none"> <li><b>Do not tamper with the interlock switches.</b></li> <li><b>Check the operation of the interlock switches daily and replace any damaged switches before operating the machine.</b></li> </ul>		

The safety interlock system is designed to prevent the engine from starting if:

- The throttle lever is all the way back, to stop.
- The blade control lever (PTO) is engaged.

The safety interlock system is also designed to stop the engine if you released the bail with the PTO engaged or move the throttle all the way back, to stop.

## Testing the Safety Interlock System

Test the safety interlock system before you use the machine each time. If the safety system does not operate as described below, have an Authorized Service Dealer repair the safety system immediately.

1. Set the parking brake, disengage the PTO and place the throttle forward. Start the engine. With the engine running squeeze the bail against upper control bar and push the mower blade control lever forward. The mower blades begin rotating.
2. With the engine running, release the bail. The engine should stop.
3. Start the engine again.
4. With the engine running, move the throttle lever all the way back, to stop. The engine should stop.

## Driving Forward or Backward

The throttle control regulates the engine speed as measured in rpm (revolutions per minute). Place the throttle control in the fast position for best performance.

### Driving Forward

1. To go forward, move the shift lever to a forward gear.
2. Release the parking brake; refer to Releasing the Parking Brake, page 17.
3. Slowly press on the upper control bar to move forward (Fig. 18).

To go straight, apply equal pressure to both ends of the upper control bar (Fig. 18).

To turn, release pressure on the upper control bar side toward the direction you want to turn (Fig. 18).

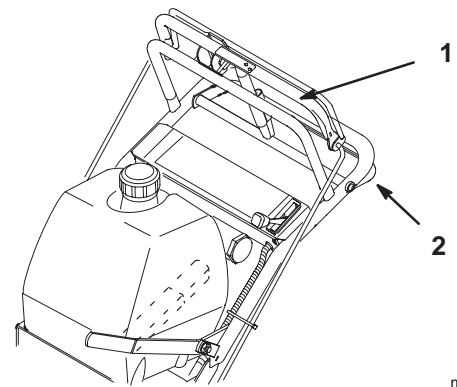

m-4194

**Figure 18**

1. Upper control bar
2. Lower control bar

### Driving Backward

1. To go backward, move the shift lever to a reverse gear.
2. Release the parking brake; refer to Releasing the Parking Brake, page 17.
3. Slowly squeeze on the lower control bar and handle together to move rearward (Fig. 18).

## Operating the Lower Control Bar

This procedure is for driving up a curb. This can be performed while driving forward or backward.

1. Disengage the mower blades.

⚠Warning⚠

**A blade can be bent or damaged when driving up a curb. Pieces of blade that may be thrown could seriously injure or kill you or bystanders.**

- **Do not run blades while driving up a curb forward or backward.**

2. Select first gear or reverse to drive machine.
3. Drive machine until drive wheels contact curb (Fig. 20).

**Note:** Both drive wheels should contact the curb and caster wheels straight.

4. At the same time engage lower control bar and lift up on handle (Fig. 19 and 20).

**Note:** Lifting up on handle will assist driving the machine up a curb and not spin the drive wheels.

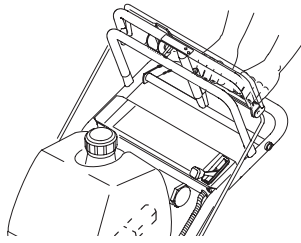

m-5704

**Figure 19**

1. Lower Control Bar (Engaged)
2. Handle

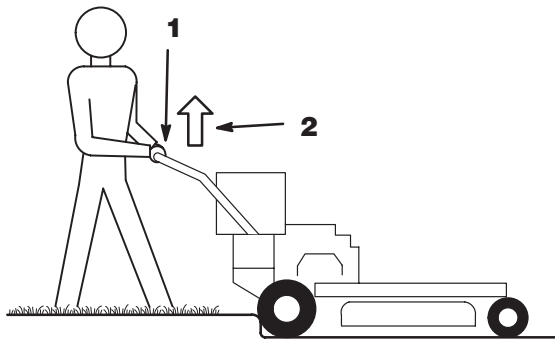

m-4185

**Figure 20**

1. Lower Control Bar engaged and mower in reverse.
2. Pull up to assist machine

## Stopping the Machine

To stop the machine apply the brakes, pull back on the upper control bar, release the bail and set the parking brake; refer to Setting the Parking Brake, page 17.



### Caution



**Children or bystanders may be injured if they move or attempt to operate the machine while it is unattended.**

**Always set the parking brake when leaving the machine unattended, even if just for a few minutes.**

## Using Side Discharge or Mulch Grass

This mower has a hinged grass deflector that disperses clippings to the side and down toward the turf.



### Danger



**Without the grass deflector, discharge cover, or complete grass catcher assembly mounted in place, you and others are exposed to blade contact and thrown debris. Contact with rotating mower blade(s) and thrown debris will cause injury or death.**

- **Never remove the grass deflector from the mower because the grass deflector routes material down toward the turf. If the grass deflector is ever damaged, replace it immediately.**
- **Never put your hands or feet under the mower.**
- **Never try to clear discharge area or mower blades unless you release the bail and the power take off (PTO) is off. Also pull the wire off the spark plug(s).**

## Adjusting Height-of-Cut

This machine has a 1 to 4-1/4 in. (26 to 108 mm) range for height-of-cut. This can be achieved by adjusting blade spacers, rear axle height and front caster spacers. Use the Height-of-Cut chart on page 22 to select the combination required

## Adjusting the Blade Height

Blades are adjusted by using the four, 1/4 in. (6 mm) spacers found on the blade spindle bolts. This allows a range, in 1/4 in. (6 mm) increments, of cutting height in any axle position. The same number of blade spacers must be used on all blades to achieve a level cut (two above and two below, one above and three below, etc.).

1. Stop engine and remove spark plug wire(s).
2. Hold blade bolt and remove nut. Slide bolt down, through spindle, and change spacers as required (Fig. 21).
3. Insert bolt, add extra spacer(s), and secure with thin washer and nut (Fig. 21).

- Torque blade bolt to 75–80 ft. lb. (101–108 N•m).

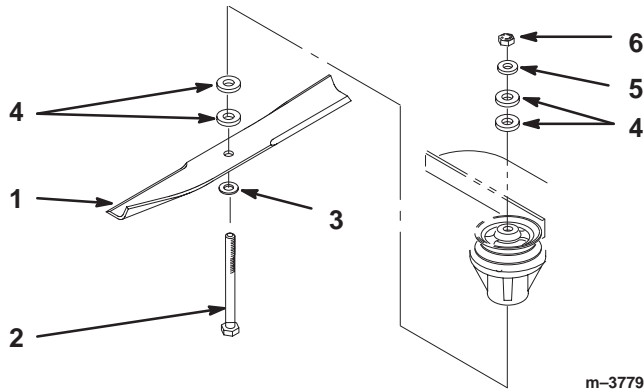

**Figure 21**

- |                |                |
|----------------|----------------|
| 1. Blade       | 4. Spacer      |
| 2. Blade bolt  | 5. Thin washer |
| 3. Cone washer | 6. Nut         |

## Adjusting the Axle Height

Desired height-of-cut range can be obtained by adjusting the rear axle and placing caster spacers above or below the caster arm (see chart).

- Stop engine and remove spark plug wire(s).
- Loosen but do not remove the 2 axle pivot bolts and the 2 axle adjustment bolts (Fig. 22).
- Place a jack under the rear center of the engine frame. Raise the back end of the engine frame up enough to remove front 2 axle adjustment bolts (Fig. 22).
- Raise or lower the engine frame with the jack, so that front 2 axle adjustment bolts can be installed in the desired hole location (Fig. 22). A tapered punch can be used to help align the holes.
- Tighten all 4 bolts and lower the unit.
- Adjust control rods and brake linkages as required. Refer to Servicing the Brake on page 30 and Installing the Traction Control Rod on page 14.

**Important** It will be necessary to adjust control rods and brake linkage when changing axle positions for proper traction and brake function.

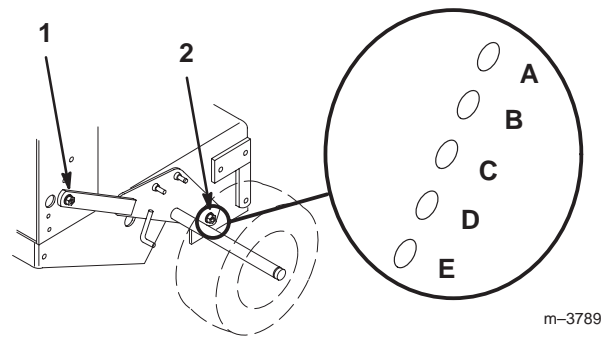
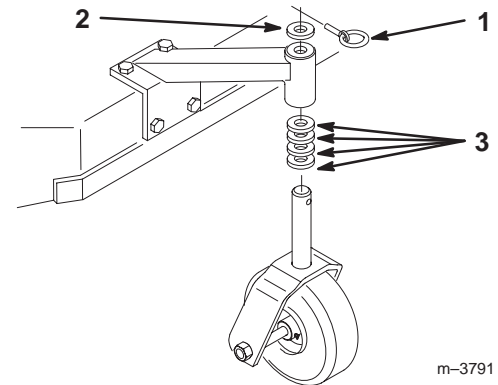

**Figure 22**

- Axle pivot bolt
- Axle adjustment bolt

## Adjusting the Caster Position

- Using the height-of-cut chart, adjust the caster spacers to match with the axle hole selected (Fig. 23).
- Remove clevis pin, slide caster from support and change spacers (Fig. 23).
- Install caster in support and insert clevis pin (Fig. 23).



**Figure 23**

- Clevis pin
- Spacer, 3/16 in. (5 mm)
- Spacer, 1/2 in. (13 mm)

## Height-of-Cut Chart

Axle Position	No. of Spacers Below Caster		Number of 1/4 in. Blade Spacers Below Spindle				
	1/2 in. (13mm)	3/16 in. (5 mm)	4	3	2	1	0
A	0	0	1 in. (26 mm)	1-1/4 in. (32 mm)	1-1/2 in. (38 mm)	1-3/4 in. (45 mm)	2 in. (45 mm)
A	0	1	1-1/8 in. (29 mm)	1-3/8 in. (35 mm)	1-5/8 in. (41 mm)	1-7/8 in. (48 mm)	2-1/8 in. (55 mm)
A	1	0	1-3/8 in. (35 mm)	1-5/8 in. (41 mm)	1-7/8 in. (48 mm)	2-1/8 in. (55 mm)	2-3/8 in. (55 mm)
B	0	1	1-3/8 in. (35 mm)	1-5/8 in. (41 mm)	1-7/8 in. (48 mm)	2-1/8 in. (55 mm)	2-3/8 in. (61 mm)
B	1	0	1-5/8 in. (41 mm)	1-7/8 in. (48 mm)	2-1/8 in. (55 mm)	2-3/8 in. (61 mm)	2-5/8 in. (67 mm)
B	1	1	1-3/4 in. (45 mm)	2 in. (52 mm)	2-1/4 in. (58 mm)	2-1/2 in. (64 mm)	2-3/4 in. (70 mm)
B	2	0	2 in. (45 mm)	2-1/4 in. (58 mm)	2-1/2 in. (64 mm)	2-3/4 in. (70 mm)	3 in. (76 mm)
C	1	1	1-7/8 in. (48 mm)	2-1/8 in. (55 mm)	2-3/8 in. (61 mm)	2-5/8 in. (67 mm)	2-7/8 in. (73 mm)
C	2	0	2-1/8 in. (55 mm)	2-3/8 in. (61 mm)	2-5/8 in. (67 mm)	2-7/8 in. (73 mm)	3-1/8 in. (79 mm)
C	2	1	2-1/4 in. (58 mm)	2-1/2 in. (64 mm)	2-3/4 in. (70 mm)	3 in. (76 mm)	3-1/4 in. (82 mm)
C	3	0	2-1/2 in. (64 mm)	2-3/4 in. (70 mm)	3 in. (76 mm)	3-1/4 in. (82 mm)	3-1/2 in. (89 mm)
D	2	1	2-3/8 in. (61 mm)	2-5/8 in. (67 mm)	2-7/8 in. (73 mm)	3-1/8 in. (79 mm)	3-3/8 in. (86 mm)
D	3	0	2-1/2 in. (64 mm)	2-3/4 in. (70 mm)	3 in. (76 mm)	3-1/4 in. (82 mm)	3-1/2 in. (89 mm)
D	3	1	2-3/4 in. (70 mm)	3 in. (76 mm)	3-1/4 in. (82 mm)	3-1/2 in. (89 mm)	3-3/4 in. (96 mm)
D	4	0	3 in. (76 mm)	3-1/4 in. (82 mm)	3-1/2 in. (89 mm)	3-3/4 in. (96 mm)	4 in. (102 mm)
E	3	1	2-7/8 in. (73 mm)	3-1/8 in. (79 mm)	3-3/8 in. (86 mm)	3-5/8 in. (92 mm)	3-7/8 in. (99 mm)
E	4	0	3-1/8 in. (79 mm)	3-3/8 in. (86 mm)	3-5/8 in. (92 mm)	3-7/8 in. (99 mm)	4-1/8 in. (105 mm)
E	4	1	3-1/4 in. (82 mm)	3-1/2 in. (89 mm)	3-3/4 in. (96 mm)	4 in. (102 mm)	4-1/4 in. (108 mm)

# Maintenance

**Note:** Determine the left and right sides of the machine from the normal operating position.

**Important** Refer to your engine operator’s manual for additional maintenance procedures.

## Recommended Maintenance Schedule

Maintenance Service Interval	Maintenance Procedure
Each Use	<ul style="list-style-type: none"> <li>• Engine Oil—check level</li> <li>• Safety System—check</li> <li>• Brake—check</li> <li>• Engine—clean cooling system</li> <li>• Idler Pivots—grease</li> </ul>
After first 8 Hours	<ul style="list-style-type: none"> <li>• Engine Oil—change</li> <li>• Mower Belt—check tension</li> </ul>
8 Hours	<ul style="list-style-type: none"> <li>• Cutting Blades—check</li> <li>• Mower Housing—clean</li> <li>• Caster Wheels—grease</li> <li>• Wheel Bearings—grease<sup>1</sup></li> </ul>
After first 25 Hours	<ul style="list-style-type: none"> <li>• Mower Belt—check tension</li> </ul>
25 Hours	<ul style="list-style-type: none"> <li>• Foam Air Cleaner—clean<sup>1</sup></li> <li>• Paper Air Cleaner—clean<sup>1</sup></li> </ul>
50 Hours	<ul style="list-style-type: none"> <li>• Belts—check for wear/cracks</li> <li>• Mower Belt—check tension</li> <li>• Mower Belt Idler Pivots—grease</li> <li>• Tires—check pressure</li> <li>• Engine Oil—change<sup>1</sup></li> </ul>
100 Hours	<ul style="list-style-type: none"> <li>• Engine—clean outside</li> <li>• Transmission Couplings—grease<sup>1</sup></li> <li>• Spark Plug(s)—check</li> <li>• Engine Oil Filter—change (100 hours or every other oil change)</li> </ul>
200 Hours	<ul style="list-style-type: none"> <li>• Fuel Filter—replace</li> </ul>
300 Hours	<ul style="list-style-type: none"> <li>• Paper Air Cleaner—replace<sup>1</sup></li> </ul>
At storage	<ul style="list-style-type: none"> <li>• Chipped Surfaces—paint</li> <li>• Perform all maintenance procedures listed above before storage</li> </ul>

<sup>1</sup>More often in dusty, dirty conditions.

**Important** Refer to your engine operator’s manual for additional maintenance procedures.



## Caution



Someone could accidentally start the engine and seriously injure you or other bystanders.

Disconnect the wire from the spark plug(s) before you do any maintenance. Set the wire aside so that it does not accidentally contact the spark plug.

## Servicing the Cutting Blades

To ensure a superior quality of cut, keep the blades sharp. For convenient sharpening and replacement, you may want to keep extra blades on hand.



## Warning



A worn or damaged blade can break, and a piece of the blade could be thrown into the operator's or bystander's area, resulting in serious personal injury or death.

- Inspect the blade periodically for wear or damage.
- Replace a worn or damaged blade.

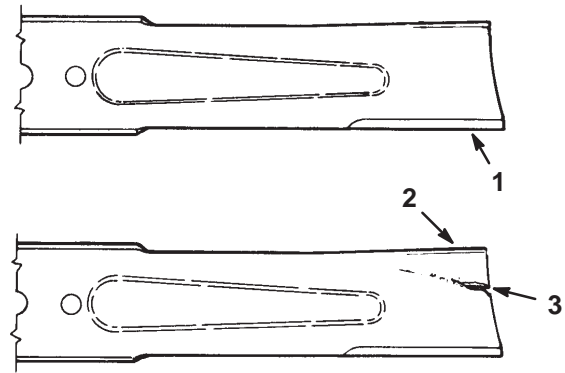

m-151

Figure 24

1. Cutting Edge
2. Curved Area
3. Wear/slot Forming

## Before Inspecting or Servicing the Blades

Park the machine on a level surface, disengage the blade control (PTO) and set the parking brake.

## Inspecting the Blades

1. Inspect the cutting edges (Fig 24). If the edges are not sharp or have nicks, remove and sharpen the blades. Refer to Sharpening the Blades on page 25.
2. Inspect the blades, especially the curved area (Fig. 24). If you notice any damage, wear, or a slot forming in this area (item 3 in Fig. 24), immediately install a new blade.

## Checking for Bent Blades

1. Rotate the blades until the ends face forward and backward (Fig. 25). Measure from a level surface to the cutting edge of the blades (Fig. 26). Note this dimension.

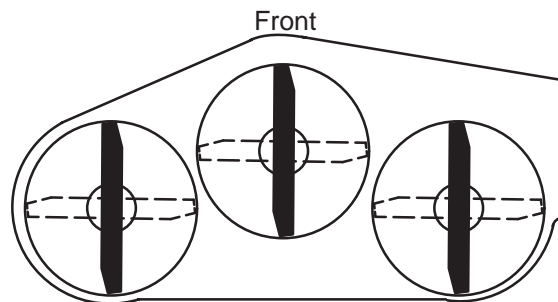

m-1078

Figure 25

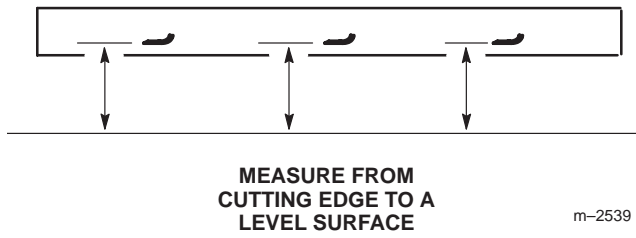

**Figure 26**

2. Rotate the opposite ends of the blades forward.
3. Measure from a level surface to the cutting edge of the blades at the same position as in step 1 above. The difference between the dimensions obtained in steps 1 and 2 must not exceed 1/8 in. (3 mm). If this dimension exceeds 1/8 in. (3 mm), the blade is bent and must be replaced. Refer to Removing the Blades, and Installing the Blades on page 26.

⚠
Warning
⚠

**A blade that is bent or damaged could break apart and could seriously injure or kill you or bystanders.**

- Always replace bent or damaged blade with a new blade.
- Never file or create sharp notches in the edges or surfaces of blade.

### Removing the Blades

Blades must be replaced if a solid object is hit, if the blade is out of balance or is bent. To ensure optimum performance and continued safety conformance of the machine, use genuine TORO replacement blades. Replacement blades made by other manufacturers may result in non-conformance with safety standards.

Hold the blade bolt with a wrench. Remove the nut, blade bolt, cone washer, blade, spacers and thin washer from the spindle (Fig. 27).

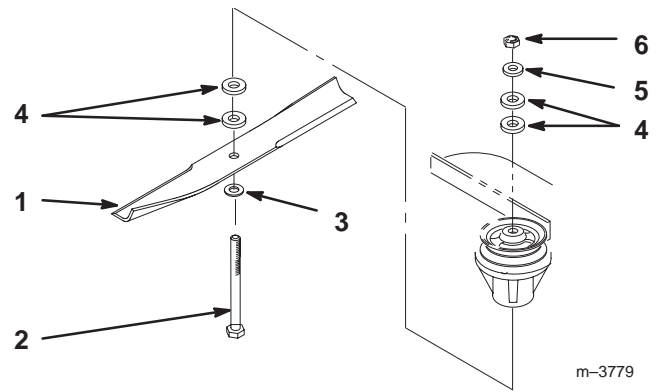
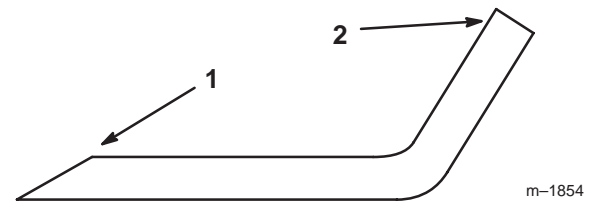

**Figure 27**

- |                |                |
|----------------|----------------|
| 1. Blade       | 4. Spacer      |
| 2. Blade bolt  | 5. Thin washer |
| 3. Cone washer | 6. Nut         |

### Sharpening the Blades

1. Use a file to sharpen the cutting edge at both ends of the blade (Fig. 28). Maintain the original angle. The blade retains its balance if the same amount of material is removed from both cutting edges.



**Figure 28**

- |                              |         |
|------------------------------|---------|
| 1. Sharpen at original angle | 2. Sail |
|------------------------------|---------|

2. Check the balance of the blade by putting it on a blade balancer (Fig. 29). If the blade stays in a horizontal position, the blade is balanced and can be used. If the blade is not balanced, file some metal off the end of the sail area only (Fig. 28). Repeat this procedure until the blade is balanced.

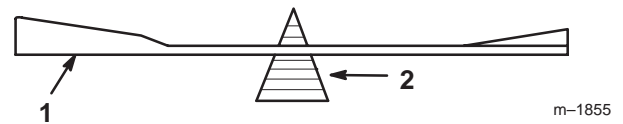

**Figure 29**

- |          |             |
|----------|-------------|
| 1. Blade | 2. Balancer |
|----------|-------------|

## Installing the Blades

1. Place the blade onto the bolt, over cone washer. Select proper number of spacer(s) for height-of-cut and slide bolt into spindle (Fig. 27).

**Important** The curved part of the blade must be pointing upward toward the inside of the mower to ensure proper cutting.

2. Install remaining spacer(s) and secure with thin washer and nut (Fig. 27).
3. Torque the blade bolt to 75–80 ft. lb. (101–108 N•m).

## Servicing the Air Cleaner

### Service Interval/Specification

Foam Element: Clean and re-oil after every 25 operating hours.

Paper Element: Clean every 25 operating hours. Replace after every 300 operating hours.

**Note:** Service the air cleaner more frequently (every few hours) if operating conditions are extremely dusty or sandy.

### Removing the Foam and Paper Elements

1. Disengage the power take off (PTO)<sup>b</sup> and set the parking brake.
2. Clean around the air cleaner to prevent dirt from getting into the engine and causing damage. Unscrew the cover nuts and remove the air cleaner cover (Fig. 30).
3. Remove the air cleaner assembly (Fig. 30).
4. Carefully slide the foam element off the paper element (Fig. 30).

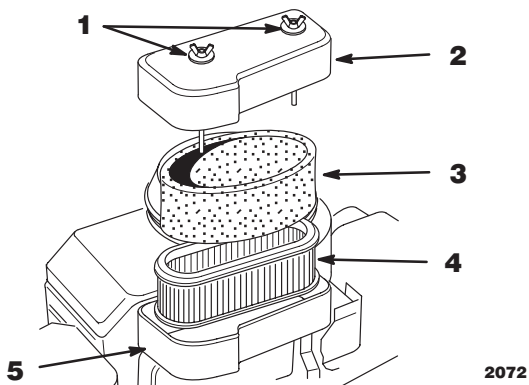

Figure 30

1. Cover nut
2. Air cleaner cover
3. Foam element
4. Paper element
5. Air cleaner base

## Cleaning the Foam Element

1. Wash the foam element in liquid soap and warm water. When the element is clean, rinse it thoroughly.
2. Dry the element by squeezing it in a clean cloth.
3. Put one or two ounces of oil on the element (Fig. 31). Squeeze the element to distribute the oil.

**Important** Replace the foam element if it is torn or worn.

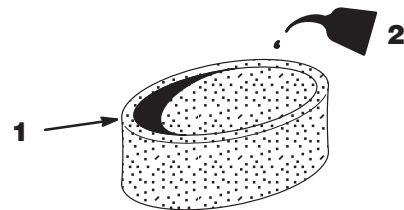

Figure 31

1. Foam element
2. Oil

## Cleaning the Paper Element

1. Lightly tap the element on a flat surface to remove dust and dirt (Fig. 32).
2. Inspect the element for tears, an oily film, and damage to the rubber seal.

**Important** Never clean the paper element with pressurized air or liquids, such as solvent, gas, or kerosene. Replace the paper element if it is damaged, defective, or cannot be cleaned thoroughly.

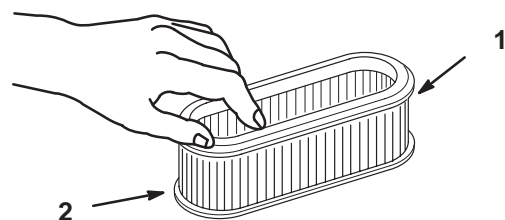

Figure 32

1. Paper element
2. Rubber seal

## Installing the Foam and Paper Elements

**Important** To prevent engine damage, always operate the engine with the complete foam and paper air cleaner assembly installed.

1. Carefully slide the foam element onto the paper air cleaner element (Fig. 30).
2. Place the air cleaner assembly onto the air cleaner base (Fig. 30).
3. Install the air cleaner cover and secure with cover nuts (Fig. 30).

## Servicing the Engine Oil

### Service Interval/Specification

Change oil:

- After the first 8 operating hours.
- After every 50 operating hours.

**Note:** Change oil more frequently when operating conditions are extremely dusty or sandy.

Oil Type: Detergent oil (API service SF, SE/CC, CD or SE)

Crankcase Capacity: with filter, 54 oz. (1.6 l)  
with out filter, 47 oz. (1.4 l)

Viscosity: See table below

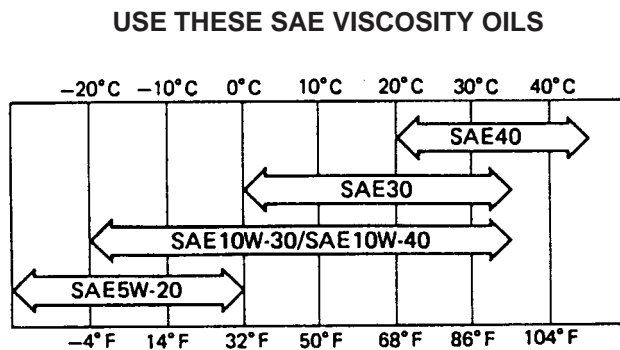

### Checking the Engine Oil Level

1. Park the machine on a level surface, disengage the power take off (PTO) and set the parking brake.
2. Clean around the oil dipstick (Fig. 33) so dirt cannot fall into the filler hole and damage the engine.
3. Unscrew the oil dipstick and wipe the metal end clean (Fig. 33).
4. Slide the oil dipstick fully into the filler tube, do not thread onto tube (Fig. 33). Pull the dipstick out and look at the metal end. If oil level is low, slowly pour only enough oil into the filler tube to raise the level to the full mark.

**Important** Do not overfill the crankcase with oil because the engine may be damaged.

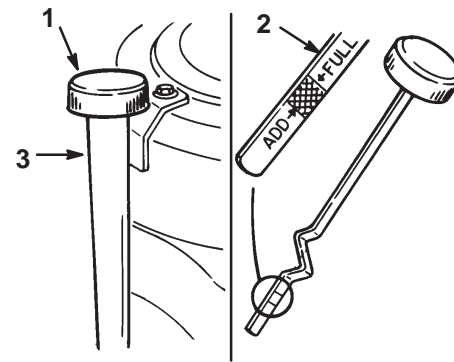

**Figure 33**

1. Oil dipstick
2. Metal end
3. Filler tube

### Changing the Oil

1. Start the engine and let it run five minutes. This warms the oil so it drains better.
2. Park the machine so that the drain side is slightly lower than the opposite side to assure the oil drains completely. Then disengage the power take off (PTO) and set the parking brake.
3. Place a pan below the oil drain. Remove the oil drain plug (Fig. 34).
4. When oil has drained completely, install the oil drain plug.

**Note:** Dispose of the used oil at a certified recycling center.

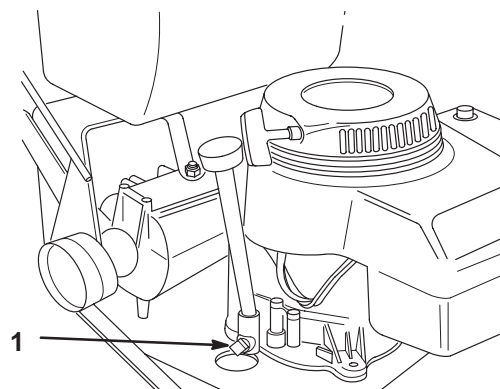

**Figure 34**

1. Oil drain plug

5. Slowly pour approximately 80% of the specified oil, on page 27, into the filler cap (Fig. 33). Now check the oil level; refer to Checking Oil Level, page 27. Slowly add additional oil to bring it to the full mark.

m-2068

## Changing the Oil Filter

### Service Interval/Specification

Replace the oil filter every 100 hours or every other oil change.

**Note:** Change oil filter more frequently when operating conditions are extremely dusty or sandy.

1. Drain the oil from the engine; refer to Changing/Draining Oil, page 27.
2. Remove the old filter and wipe the filter adapter (Fig. 35) gasket surface.
3. Apply a thin coat of new oil to the rubber gasket on the replacement filter (Fig. 35).

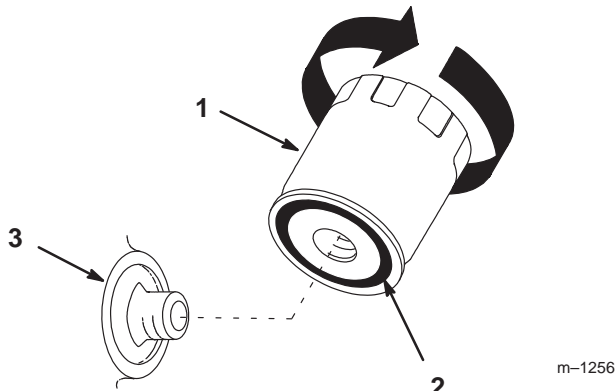

**Figure 35**

1. Oil filter
2. Gasket
3. Adapter

4. Install the replacement oil filter to the filter adapter. Turn the oil filter clockwise until the rubber gasket contacts the filter adapter, then tighten the filter an additional 3/4 turn (Fig. 35).
5. Fill the crankcase with the proper type of new oil; refer to Changing/Draining Oil, page 27.

## Servicing the Spark Plug

### Service Interval/Specification

Check the spark plug(s) after every 100 operating hours. Make sure the air gap between the center and side electrodes is correct before installing the spark plug. Use a spark plug wrench for removing and installing the spark plug(s) and a gapping tool/feeler gauge to check and adjust the air gap. Install a new spark plug(s) if necessary.

Type: NGK BMR-4A, Champion RCJ-8  
(or equivalent) Air Gap: 0.025 in. (0.65 mm)

## Removing the Spark Plug(s)

1. Disengage the power take off (PTO) and set the parking brake.
2. Pull the wire(s) off the spark plug(s) (Fig. 36). Now clean around the spark plug(s) to prevent dirt from falling into the engine and potentially causing damage.
3. Remove the spark plug(s) and metal washer.

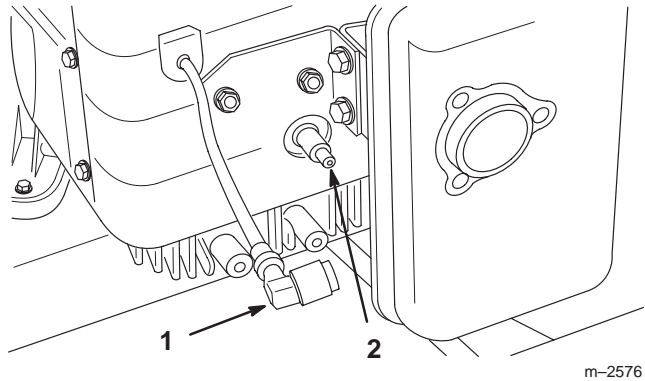

**Figure 36**

1. Spark plug wire
2. Spark plug

## Checking the Spark Plug

1. Look at the center of the spark plug(s) (Fig. 37). If you see light brown or gray on the insulator, the engine is operating properly. A black coating on the insulator usually means the air cleaner is dirty.

**Important** Never clean the spark plug(s). Always replace the spark plug(s) when it has: a black coating, worn electrodes, an oily film, or cracks.

2. Check the gap between the center and side electrodes (Fig. 37). Bend the side electrode (Fig. 37) if the gap is not correct.

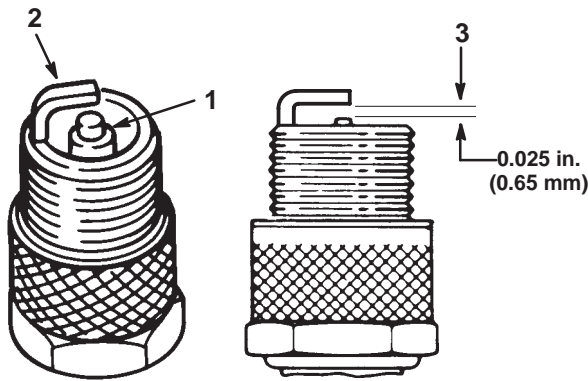

**Figure 37**

1. Center electrode insulator      3. Air gap (not to scale)  
 2. Side electrode

## Installing the Spark Plug(s)

1. Install the spark plug(s) and metal washer. Make sure the air gap is set correctly.
2. Tighten the spark plug(s) to 18 ft-lb (24 N.m).
3. Push the wire(s) onto the spark plug(s) (Fig. 36).

## Checking the Tire Pressure

### Service Interval/Specification

Maintain the air pressure in the front and rear tires as specified. Check the pressure at the valve stem after every 50 operating hours or monthly, whichever occurs first (Fig. 38). Check the tires when they are cold to get the most accurate pressure reading.

Pressure: 15 psi (103 kPa) rear tires  
 25–30 psi (172–207 kPa) caster tires

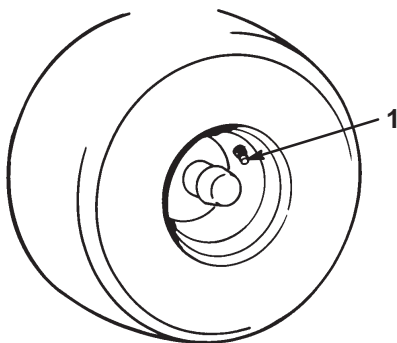

**Figure 38**

1. Valve stem

## Cleaning the Cooling System

### Service Interval/Specification

Before each use, check and clean engine cooling system. Remove any build-up of grass, dirt or other debris from the cylinder and cylinder head cooling fins, air intake screen on flywheel end, and carburetor-governor levers and linkage. This will help insure adequate cooling and correct engine speed and will reduce the possibility of overheating and mechanical damage to the engine.

## Greasing and Lubrication

### Service Interval/Specification

Grease the areas shown and at intervals in Where to Add Grease section below. Grease more frequently when operating conditions are extremely dusty or sandy.

Grease with No. 2 general purpose lithium base or molybdenum base grease.

### How to Grease

1. Disengage the blade control (PTO) and set the parking brake.
2. Clean the grease fittings with a rag. Make sure to scrape any paint off the front of the fitting(s).
3. Connect a grease gun to the fitting. Pump grease into the fittings until grease begins to ooze out of the bearings.
4. Wipe up any excess grease.

### Where to Add Grease

1. Lubricate the drive and caster wheel bearings and front spindles (Fig. 39). Lubricate every 8 hours.

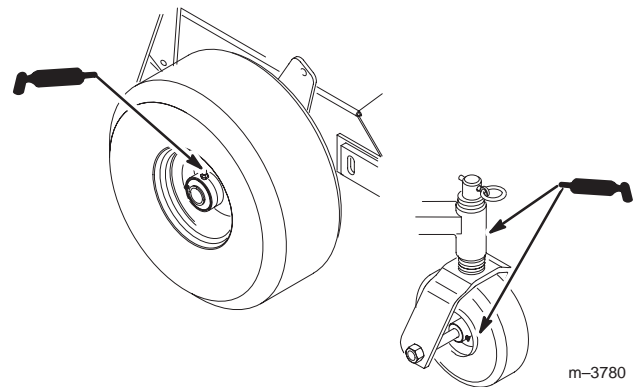

**Figure 39**

2. Lubricate the transmission couplers every 100 hours and idler arm pivots every 8 hours (Fig 40).

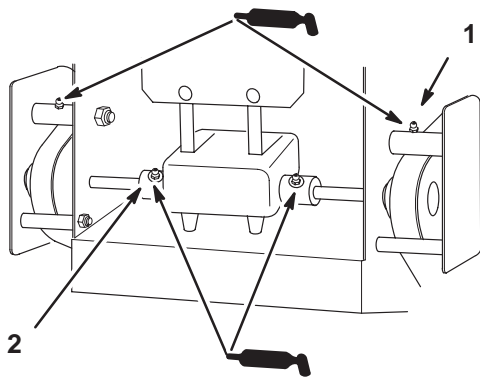

m-3797

**Figure 40**

1. Idler Arm Pivots                      2. Transmission Couplers

3. Lubricate the blade belt idler arm pivot. (Fig. 41).  
Lubricate every 50 hours.

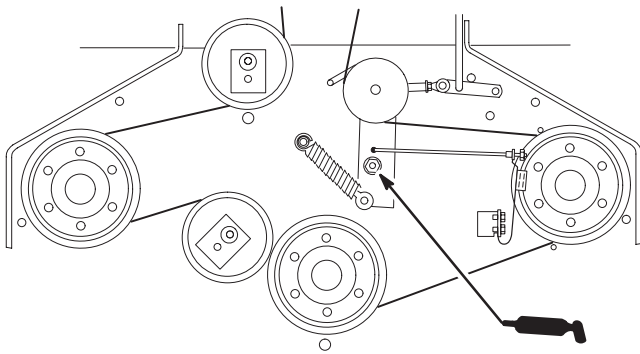

m-4731

**Figure 41**

2. Rear wheels must lock when you try to push the machine forward or backward. Adjustment is required if the wheels turn and do not lock; refer to Adjusting the Brake, page 30.
3. Release the brake and press upper control bar very lightly, approximately 1/2 in. (13 mm), wheels should rotate freely.
4. If both conditions are met, no adjustment is required.

## Adjusting the Brakes

The brake lever is on the upper control bar (Fig. 14). If the parking brake does not hold securely, an adjustment is required.

1. Check the brake before you adjust it; refer to Checking the Brake, page 30.
2. Release the parking brake; refer to Releasing the Parking Brake, page 17.
3. To adjust brake set the parking brake latch, and rotate the wing nuts on the brake rods (Fig. 42). Clockwise to tighten the brake and counterclockwise to loosen the brake.

**Note:** Control bar should be parallel with reference bar when properly adjusted.

4. Check the brake operation again; refer to Checking the Brake, page 30.

**Important** With the parking brake released, the rear wheels must rotate freely when you push the mower. If brake action and free wheel rotation cannot be achieved contact your service dealer immediately.

## Servicing the Brakes

### Service Interval/Specification

Before each use, check brakes for proper operation.

Always set the parking brake when you stop the machine or leave it unattended. If the parking brake does not hold securely, an adjustment is required.

### Checking the Brakes

1. Park the machine on a level surface, disengage the blade control (PTO) and set the parking brake.

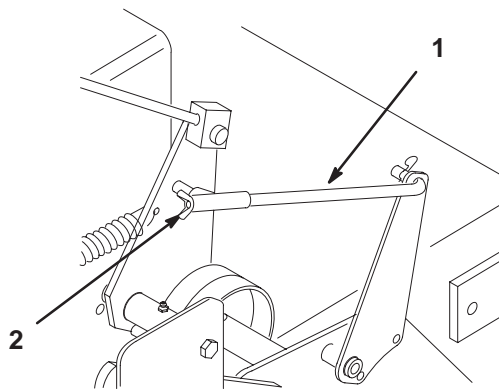

**Figure 42**

1. Brake rod
2. Wing nut

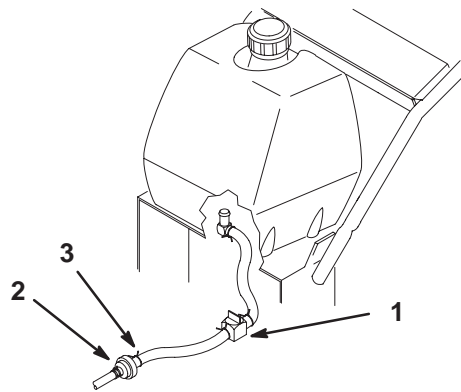

**Figure 43**

1. Fuel shut-off valve
2. Fuel filter
3. Clamp

## Servicing the Fuel Tank

### Draining The Fuel Tank

⚠
Danger
⚠

**In certain conditions, gasoline is extremely flammable and highly explosive. A fire or explosion from gasoline can burn you and others and can damage property.**

- **Drain gasoline from the fuel tank when the engine is cold. Do this outdoors in an open area. Wipe up any gasoline that spills.**
- **Never smoke when draining gasoline, and stay away from an open flame or where a spark may ignite the gasoline fumes.**

1. Park the machine on a level surface, to assure fuel tank drains completely. Then disengage the blade control (PTO) and set the parking brake.
2. Close the fuel shut-off valve in fuel line (Fig. 43).
3. Squeeze the ends of the hose clamp together and slide it up the fuel line away from fuel filter (Fig. 43).
4. Pull the fuel line off the fuel filter (Fig. 43). Open fuel shut-off valve and allow gasoline to drain into a gas can or drain pan.

**Note:** Now is the best time to install a new fuel filter because the fuel tank is empty. Refer to Replacing the Fuel Filter; page 31.

5. Install the fuel line onto the fuel filter. Slide the hose clamp close to the filter to secure the fuel line.

## Servicing the Fuel Filter

### Service Interval/Specification

Replace the fuel filter after every 200 operating hours or yearly, whichever occurs first.

### Replacing the Fuel Filter

Never install a dirty filter if it is removed from the fuel line.

1. Disengage the blade control (PTO) and set the parking brake. Stop engine.
2. Close fuel shut-off valve (Fig. 43).
3. Squeeze the ends of the hose clamps together and slide them away from the filter (Fig. 44).
4. Remove the filter from the fuel lines.
5. Install a new filter and move the hose clamps close to the filter.
6. Open the fuel shut-off valve at the fuel tank (Fig. 43).

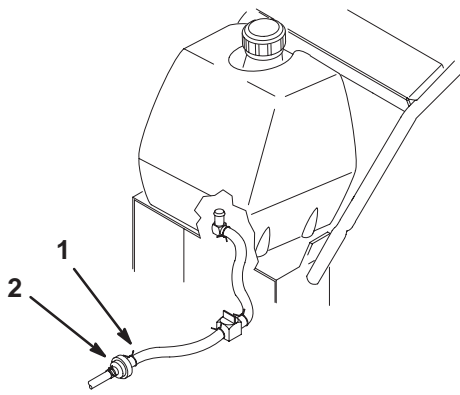

m-3778

**Figure 44**

1. Hose clamp
2. Filter

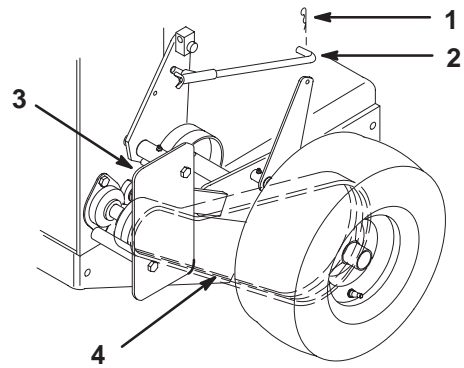

m-3793

**Figure 45**

1. Hairpin cotter
2. Brake rod
3. Shield
4. Drive belt

## Checking the Belts

### Service Interval/Specification

Check all belts after every 50 operating hours or monthly, whichever occurs first. Look for dirt, wear, cracks and signs of overheating.

## Replacing the Wheel Belt

1. Remove hairpin cotter securing brake rod to brake arm to relax belt idler tension (Fig. 45).
2. Remove bottom and loosen top bolts of shield to rotate for belt clearance (Fig. 45).
3. Lift belt past idler and off drive pulley (Fig. 45).
4. Raise wheel off ground enough to allow belt removal.

**Note:** Make sure that the mud and grass scraper is adjusted properly and centered in the pulley grooves (see page 34). The pointed part of the scraper should be centered and as deep in the pulley groove as possible, without rubbing at any point.

5. Replace the drive belt.
6. Secure shield with previously removed bolt and tighten bolts (Fig. 45).
7. Secure brake rod to brake arm with hairpin cotter (Fig. 45).

## Replacing the Traction Belt

1. Stop the engine, set the parking brake and remove the spark plug wire(s).
2. Raise the rear of the machine and hold with jack stands.
3. Remove mower belt (Fig. 47).
4. Loosen pivot bolt enough to slide idler pulley in slot and remove traction belt from the engine and drive pulleys.
5. Install new belt around engine and drive pulleys (Fig. 46).
6. Slide idler pulley in engine frame to tension traction belt (Fig. 46).
7. Install the mower belt (Fig. 47).
8. Check the belt guide under the engine frame for proper adjustment (Fig. 46). The distance between the belt guide and mower belt should be 1-3/8 in. (35mm). Adjust as necessary. The disengaged belt should not drag or fall off pulley when guides are properly adjusted.

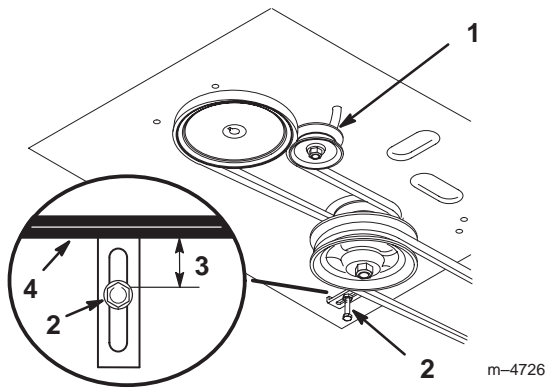

**Figure 46**

- |                  |                      |
|------------------|----------------------|
| 1. Idler in slot | 3. 1-3/8 in. (35 mm) |
| 2. Belt guide    | 4. Mower belt        |

## Replacing the Mower Belt

1. Disengage the power take off (PTO) and set the parking brake.
2. Remove the knobs and belt cover on mower.
3. Remove idler pulley and then remove worn belt (Fig. 47).
4. Install the new belt.
5. Install the idler pulley.
6. Engage PTO and check belt tension. See Adjusting Mower Belt Tension, page 33.

**Note:** Proper belt tension is 10–15 lbf. (44–67 N) with the belt deflected a 1/2 in. (13mm) halfway between pulleys (Fig. 47).

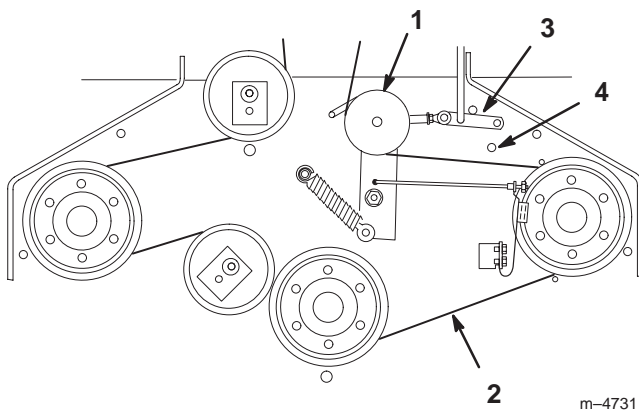

**Figure 47**

- |                                    |               |
|------------------------------------|---------------|
| 1. Idler pulley                    | 3. Assist arm |
| 2. 1/2 in. (13 mm) deflection here | 4. Front stop |

7. Engage PTO lever and check the clearance between the bellcrank and the transmission output shaft (Fig. 48). Space should be 1/16–1/8 in. (2mm–3mm).
8. Remove hairpin cotter and clevis pin from bellcrank. Rotate clevis clockwise on rod to increase or counterclockwise to decrease clearance (Fig. 48).

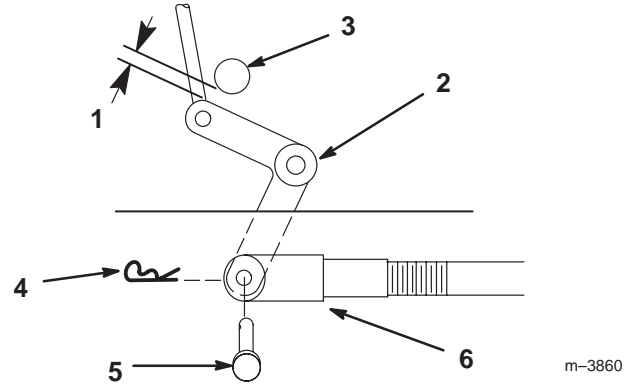

**Figure 48**

- |                              |                   |
|------------------------------|-------------------|
| 1. 1/16–1/8 in. (2mm–3mm)    | 4. Hairpin cotter |
| 2. Bellcrank                 | 5. Clevis pin     |
| 3. Transmission output shaft | 6. Clevis         |

9. Disengage the PTO. If the assist arm does not contact the front stop on the mower deck (Fig. 47), readjust the clevis to bring the bellcrank closer to the transmission output shaft (Fig. 48).
10. Check the belt guide under the engine frame for proper adjustment (Fig. 46). The distance between the belt guide and mower belt should be 1-3/8 in. (35mm). Adjust as necessary. The disengaged belt should not drag or fall off pulley when guides are properly adjusted.

## Adjusting the Mower Belt Tension

### Service Interval/Specification

Check belt tension after the first 8 and 25 hours of operation. Check the belt tension every 50 hours.

**Important** Belt must be tight enough to not slip during heavy loads while cutting grass. Over tensioning will reduce belt and spindle bearing life.

1. Disengage the power take off (PTO) and set the parking brake.
2. Loosen locknut on turnbuckle (Fig. 49).
3. Rotate turnbuckle toward rear of mower to increase tension on belt. Rotate turnbuckle toward front of mower to decrease tension on belt (Fig. 49).

**Note:** The eyebolt threads on both ends of the turnbuckle should be engaged a minimum of 5/16 in. (8mm).

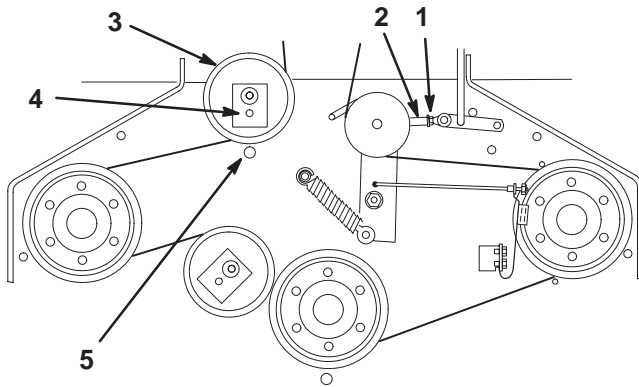

**Figure 49**

m-4731

- |                      |                                    |
|----------------------|------------------------------------|
| 1. Locknut           | 4. Front position for idler pulley |
| 2. Turnbuckle        | 5. Belt guide                      |
| 3. Rear idler pulley |                                    |

4. If the belt is still loose after making adjustments to the turnbuckle, reposition the rear idler pulley to the front hole. The belt guide next to the pulley must also be moved to the front hole (Fig. 49).

5. Readjust the turnbuckle.

## Adjusting the Blade Brake

1. Disengage the power take off (PTO) and set the parking brake.
2. If necessary, adjust the spring mounting bolts so that the blade brake pad rubs against the pulley edges (Fig. 50).
3. Adjust the nut at the end of the blade brake rod until there is 1/8–3/16 in. (3mm–5mm) between the nut and spacer (Fig. 50).
4. Engage the blades. Ensure the blade brake pad no longer contacts the pulley edges.

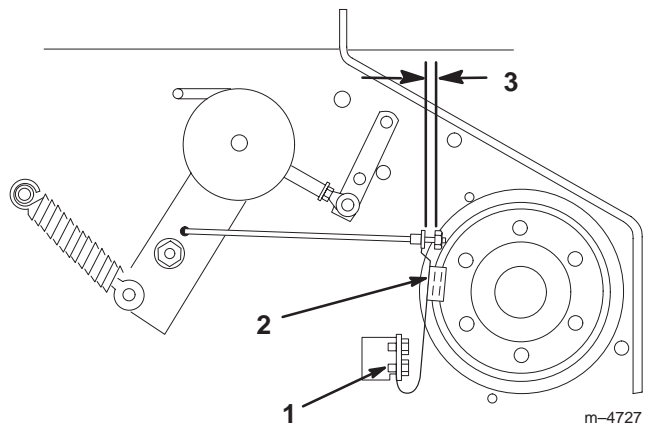

**Figure 50**

m-4727

- |                          |                           |
|--------------------------|---------------------------|
| 1. Spring mounting bolts | 3. 1/8–3/16 in. (3mm–5mm) |
| 2. Blade brake pad       |                           |

## Adjusting the Grass/Mud Scraper

1. Loosen the locknut holding scraper to the engine frame (Fig. 51).
2. Rotate scraper until they align with center of pulley grooves (Fig. 51).
3. Tighten the locknut (Fig. 51).

**Note:** The scraper must not contact the pulley on the sides or bottom of grooves. Re-adjust if necessary.

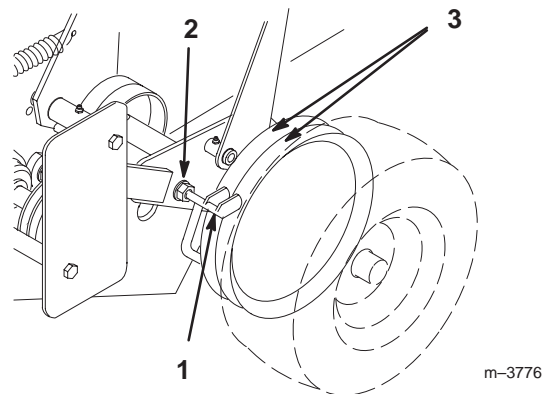

**Figure 51**

m-3776

- |            |           |
|------------|-----------|
| 1. Scraper | 3. Pulley |
| 2. Locknut |           |

# Replacing the Grass Deflector



## Warning



An uncovered discharge opening could allow the lawn mower to throw objects in the operator's or bystander's direction and result in serious injury. Also, contact with the blade could occur.

Never operate the lawn mower unless you install a cover plate, a mulch plate, or a grass chute and catcher.

1. Remove the locknut, bolt, spring and spacer holding deflector to the mounts (Fig. 52).
2. Straighten deflector mounts if they are bent (Fig. 52).
3. Install new deflector between mounts with spacer and spring. Hook the front end of the spring around the front deflector mount. Insert bolt through spacer and secure with locknut. Confirm there is downward spring force on deflector (Fig. 52).
4. Tighten the bolt and locknut until they lightly contact the pivot brackets (Fig. 52).

**Important** The grass deflector must be spring-loaded in the down position. Lift the deflector up to test that it snaps to the full down position.

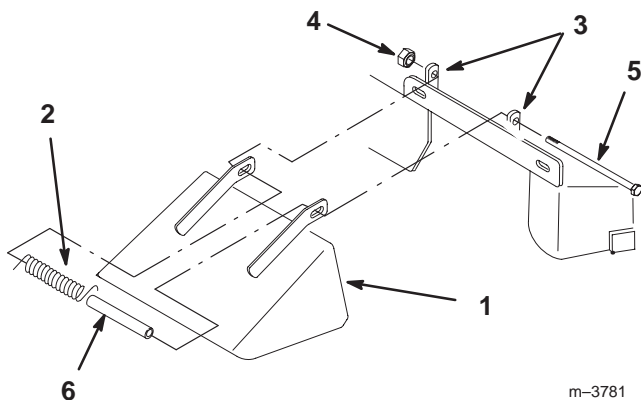

m-3781

**Figure 52**

- |                    |            |
|--------------------|------------|
| 1. Deflector       | 4. Spring  |
| 2. Bolt            | 5. Spacer  |
| 3. Deflector mount | 6. Locknut |

# Wiring Diagram

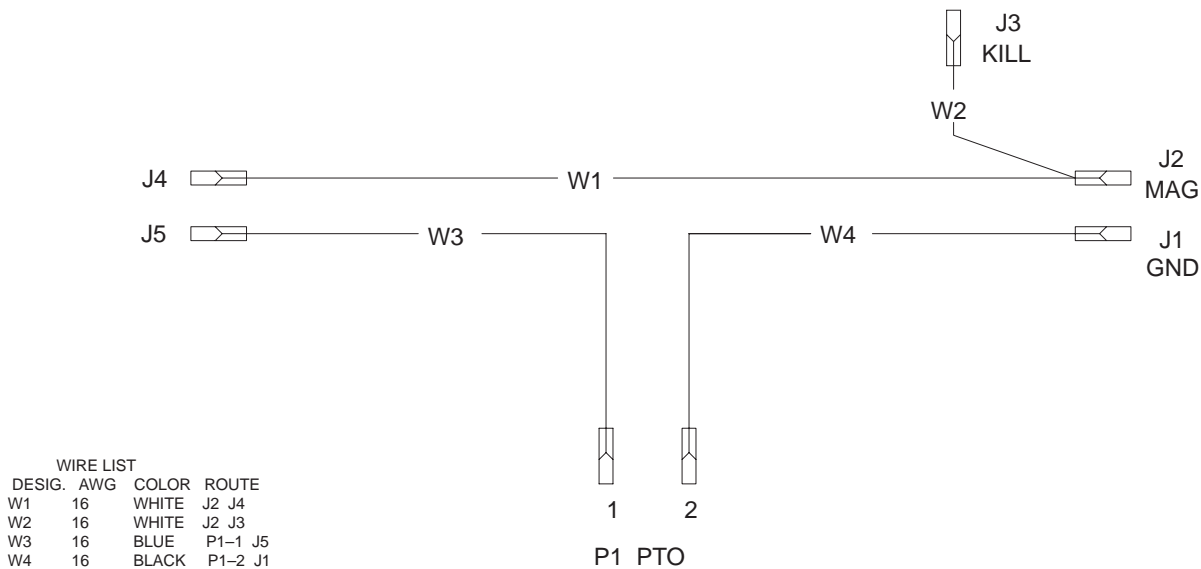

## Cleaning and Storage

1. Disengage the power take off (PTO) and set the parking brake.
2. Remove grass clippings, dirt, and grime from the external parts of the entire machine, especially the engine. Clean dirt and chaff from the outside of the engine's cylinder head fins and blower housing.

**Important** You can wash the machine with mild detergent and water. Do not pressure wash the machine. Avoid excessive use of water, especially near the control panel, and engine.

3. Check the brake; refer to Servicing the Brakes, page 30.
4. Service the air cleaner; refer to Servicing the Air Cleaner, page 26.
5. Grease the machine; refer to Greasing and Lubrication, page 29.
6. Change the crankcase oil; refer to Servicing the Engine Oil, page 27.
7. Check the tire pressure; refer to Checking the Tire Pressure, page 29.
8. For long-term storage (more than 90 days) add stabilizer/conditioner additive to fuel in the tank.

- A. Run engine to distribute conditioned fuel through the fuel system (5 minutes).
- B. Stop engine, allow to cool and drain the fuel tank; refer to Servicing the Fuel Tank, page 31, or operate engine until it stops.
- C. Restart engine and run until it stops. Repeat, on **choke** until engine will not restart.
- D. Dispose of fuel properly. Recycle as per local codes.

**Note:** Do not store stabilizer/conditioned gasoline over 90 days.

9. Remove the spark plug(s) and check its condition; refer to Servicing the Spark Plug, page 28. With the spark plug(s) removed from the engine, pour two tablespoons of engine oil into the spark plug hole. Now use the starter to crank the engine and distribute the oil inside the cylinder. Install the spark plug(s). Do not install the wire on the spark plug(s).
10. Check and tighten all bolts, nuts, and screws. Repair or replace any part that is damaged or defective.
11. Paint all scratched or bare metal surfaces. Paint is available from your Authorized Service Dealer.
12. Store the machine in a clean, dry garage or storage area. Cover the machine to protect it and keep it clean.

# Troubleshooting

Problem	Possible Causes	Corrective Action
Engine will not start, starts hard, or fails to keep running.	<ol style="list-style-type: none"> <li>1. Fuel tank is empty.</li> <li>2. Choke is not on.</li> <li>3. Air cleaner is dirty.</li> <li>4. Spark plug wire is loose or disconnected.</li> <li>5. Spark plug is pitted, fouled, or gap is incorrect.</li> <li>6. Dirt in fuel filter.</li> <li>7. Dirt, water, or stale fuel is in fuel system.</li> </ol>	<ol style="list-style-type: none"> <li>1. Fill fuel tank with gasoline.</li> <li>2. Move choke lever to on.</li> <li>3. Clean or replace air cleaner element.</li> <li>4. Install wire on spark plug.</li> <li>5. Install new, correctly gapped spark plug.</li> <li>6. Replace fuel filter.</li> <li>7. Contact Authorized Service Dealer.</li> </ol>
Engine loses power.	<ol style="list-style-type: none"> <li>1. Engine load is excessive.</li> <li>2. Air cleaner is dirty.</li> <li>3. Oil level in crankcase is low.</li> <li>4. Cooling fins and air passages under engine blower housing are plugged.</li> <li>5. Spark plug is pitted, fouled, or gap is incorrect.</li> <li>6. Vent hole in fuel cap is plugged.</li> <li>7. Dirt in fuel filter.</li> <li>8. Dirt, water, or stale fuel is in fuel system.</li> </ol>	<ol style="list-style-type: none"> <li>1. Reduce ground speed.</li> <li>2. Clean air cleaner element.</li> <li>3. Add oil to crankcase.</li> <li>4. Remove obstruction from cooling fins and air passages.</li> <li>5. Install new, correctly gapped spark plug.</li> <li>6. Clean or replace the fuel cap.</li> <li>7. Replace fuel filter.</li> <li>8. Contact Authorized Service Dealer.</li> </ol>
Engine overheats.	<ol style="list-style-type: none"> <li>1. Engine load is excessive.</li> <li>2. Oil level in crankcase is low.</li> <li>3. Cooling fins and air passages under engine blower housing are plugged.</li> </ol>	<ol style="list-style-type: none"> <li>1. Reduce ground speed.</li> <li>2. Add oil to crankcase.</li> <li>3. Remove obstruction from cooling fins and air passages.</li> </ol>
Machine does not drive.	<ol style="list-style-type: none"> <li>1. Shift lever is in neutral.</li> <li>2. Traction belt is worn, loose or broken.</li> <li>3. Traction belt is off pulley.</li> </ol>	<ol style="list-style-type: none"> <li>1. Move shift lever to a drive gear position.</li> <li>2. Change Belt.</li> <li>3. Change Belt.</li> </ol>

<b>Problem</b>	<b>Possible Causes</b>	<b>Corrective Action</b>
Abnormal vibration.	<ol style="list-style-type: none"> <li>1. Cutting blade(s) is/are bent or unbalanced.</li> <li>2. Blade mounting bolt is loose.</li> <li>3. Engine mounting bolts are loose.</li> <li>4. Loose engine pulley, idler pulley, or blade pulley.</li> <li>5. Engine pulley is damaged.</li> <li>6. Blade spindle bent.</li> </ol>	<ol style="list-style-type: none"> <li>1. Install new cutting blade(s).</li> <li>2. Tighten blade mounting bolt.</li> <li>3. Tighten engine mounting bolts.</li> <li>4. Tighten the appropriate pulley.</li> <li>5. Contact Authorized Service Dealer.</li> <li>6. Contact Authorized Service Dealer.</li> </ol>
Uneven cutting height.	<ol style="list-style-type: none"> <li>1. Blade(s) not sharp.</li> <li>2. Cutting blade(s) is/are bent.</li> <li>3. Mower is not level.</li> <li>4. Underside of mower is dirty.</li> <li>5. Tire pressure is incorrect.</li> <li>6. Blade spindle bent.</li> </ol>	<ol style="list-style-type: none"> <li>1. Sharpen blade(s).</li> <li>2. Install new cutting blade(s).</li> <li>3. Level mower from side-to-side and front-to-rear.</li> <li>4. Clean the underside of the mower.</li> <li>5. Adjust tire pressure.</li> <li>6. Contact Authorized Service Dealer.</li> </ol>
Blades do not rotate.	<ol style="list-style-type: none"> <li>1. Drive belt is worn, loose or broken.</li> <li>2. Drive belt is off pulley.</li> <li>3. Deck belt is worn, loose or broken.</li> <li>4. Deck belt is off pulley.</li> </ol>	<ol style="list-style-type: none"> <li>1. Check belt tension.</li> <li>2. Install drive belt and check adjusting shafts and belt guides for correct position.</li> <li>3. Install new deck belt.</li> <li>4. Install deck pulley and check the idler pulley, idler arm and spring for correct position and function.</li> </ol>
Blades do not stop when disengaged.	<ol style="list-style-type: none"> <li>1. Blade brake is not adjusted properly.</li> <li>2. Belt guide is not set properly.</li> </ol>	<ol style="list-style-type: none"> <li>1. Adjust blade brake.</li> <li>2. Adjust belt guide.</li> </ol>





LCE

# The Toro Total Coverage Guarantee

## A One-Year Limited Warranty

### Conditions and Products Covered

The Toro Company and its affiliate, Toro Warranty Company, pursuant to an agreement between them, jointly promise to repair any Toro Product used for commercial, institutional, or rental purposes if defective in materials or workmanship. The following time periods apply from the date of purchase:

<u>Products</u>	<u>Warranty Period</u>
• All Products	1 year
• All Spindles	2 years parts and labor; third year, parts only
• Engines/Hydraulic Systems* on the following: Outfront and Mid-Mount Z's ProLine Mid-Size Mowers Groundsmaster® Riding Mowers Backpack Blowers	2 years
• Deck Shells (36"–72") on the following: ProLine Mid-Size Mowers Mid-Mount Z's	2 years
• Electric Clutch on 200 Series Mid-Mount Z's	2 years

This warranty includes the cost of parts and labor, but you must pay transportation costs.

This warranty applies to:

- Outfront and Mid-Mount Z's
- ProLine Mid-Size Mowers
- Groundsmaster Riding Mowers
- Turf Maintenance Equipment
- Debris Management Equipment

\* Some engines used on Toro LCE Products are warranted by the engine manufacturer.

### Instructions for Obtaining Warranty Service

If you think that your Toro Product contains a defect in materials or workmanship, follow this procedure:

1. Contact any Toro Authorized or Master Service Dealer to arrange service at their dealership. To locate a dealer convenient to you, access our website at [www.Toro.com](http://www.Toro.com). U.S. Customers may also call 800-348-2424.
2. Bring the product and your proof of purchase (sales receipt) to the Service Dealer.

If for any reason you are dissatisfied with the Service Dealer's analysis or with the assistance provided, contact us at:

LCB Customer Service Department  
Toro Warranty Company  
8111 Lyndale Avenue South  
Bloomington, MN 55420-1196  
888-577-7466 (U.S. customers)  
877-484-9255 (Canada customers)

### Countries Other than the United States or Canada

Customers who have purchased Toro products exported from the United States or Canada should contact their Toro Distributor (Dealer) to obtain guarantee policies for your country, province, or state. If for any reason you are dissatisfied with your Distributor's service or have difficulty obtaining guarantee information, contact the Toro importer. If all other remedies fail, you may contact us at Toro Warranty Company.

### Owner Responsibilities

You must maintain your Toro Product by following the maintenance procedures described in the operator's manual. Such routine maintenance, whether performed by a dealer or by you, is at your expense.

### Items and Conditions Not Covered

There is no other express warranty except for special emission system coverage on some products. This express warranty does not cover the following:

- Cost of regular maintenance service or parts, such as filters, fuel, lubricants, tune-up parts, blade sharpening, brake and clutch adjustments.
- Any product or part which has been altered or misused or required replacement or repair due to normal wear, accidents, or lack of proper maintenance.
- Repairs necessary due to improper fuel, contaminants in the fuel system, or failure to properly prepare the fuel system prior to any period of non-use over three months.
- Pickup and delivery charges.

All repairs covered by this warranty must be performed by an Authorized Toro Service Dealer using Toro approved replacement parts.

### General Conditions

Repair by an Authorized Toro Service Dealer is your sole remedy under this warranty.

Neither The Toro Company nor Toro Warranty Company is liable for indirect, incidental or consequential damages in connection with the use of the Toro Products covered by this warranty, including any cost or expense of providing substitute equipment or service during reasonable periods of malfunction or non-use pending completion of repairs under this warranty.

Some states do not allow exclusions of incidental or consequential damages, or limitations on how long an implied warranty lasts, so the above exclusions and limitations may not apply to you.

All implied warranties of merchantability (that the product is fit for ordinary use) and fitness for use (that the product is fit for a particular purpose) are limited to the duration of the express warranty.

This warranty gives you specific legal rights, and you may also have other rights which vary from state to state.