



Mid-Size Traction Unit

Proline Gear 17hp

Model No. 30169—Serial No. 220000001 and Up

Operator's Manual



Warning



The engine exhaust from this product contains chemicals known to the State of California to cause cancer, birth defects, or other reproductive harm.

Important This engine is not equipped with a spark arrester muffler. It is a violation of California Public Resource Code Section 4442 to use or operate this engine on any forest-covered, brush-covered or grass-covered land. Other states or federal areas may have similar laws.

This spark ignition system complies with Canadian ICES-002.

Ce système d'allumage par étincelle de véhicule est conforme à la norme NMB-002 du Canada.

The enclosed Engine Owner's Manual is supplied for information regarding The U.S. Environmental Protection Agency (EPA) and the California Emission Control Regulation of emission systems, maintenance and warranty.

Keep this engine Owner's Manual with your unit. Should this engine Owner's Manual become damaged or illegible, replace immediately. Replacements may be ordered through the engine manufacturer.

Contents

	Page
Introduction	2
Safety	3
Safe Operating Practices	3
Toro Mower Safety	4
Slope Chart	7
Safety and Instruction Decals	9
Gasoline and Oil	11
Recommended Gasoline	11
Using Stabilizer/Conditioner	11
Filling the Fuel Tank	11
Check Engine Oil Level	11
Setup	12
Loose Parts	12
Installing the Shift Lever	12
Installing the Control Panel and Fuel Tank	13
Installing the Upper Handle	14

	Page
Connecting the Throttle Cable	14
Adjusting the Choke	15
Connecting the Wire Harness	15
Installing the Control Rods	15
Operation	16
Think Safety First	17
Controls	17
Operating the Parking Brake	17
Starting and Stopping the Engine	18
Operating the Mower Blade Control (PTO)	18
The Safety Interlock System	19
Driving Forward or Backward	19
Operating the Lower Control Bar	20
Stopping the Machine	20
Maintenance	21
Recommended Maintenance Schedule	21
Servicing the Air Cleaner	22
Servicing the Engine Oil	23
Servicing the Spark Plug	24
Greasing and Lubrication	25
Cleaning the Cooling System	25
Checking the Tire Pressure	26
Servicing the Brake	26
Servicing the Fuel Tank	26
Servicing the Fuel Filter	27
Replacing the Drive Belt	27
Replacing the Traction Belt	28
Adjusting the Electric Clutch	28
Wiring Diagram	29
Cleaning and Storage	29
Troubleshooting	30
The Toro Total Coverage Guarantee	32

Introduction

Read this manual carefully to learn how to operate and maintain your product properly. The information in this manual can help you and others avoid injury and product damage. Although Toro designs and produces safe products, you are responsible for operating the product properly and safely.

Whenever you need service, genuine Toro parts, or additional information, contact an Authorized Service Dealer or Toro Customer Service and have the model and serial numbers of your product ready. Figure 1 illustrates the location of the model and serial numbers on the product.

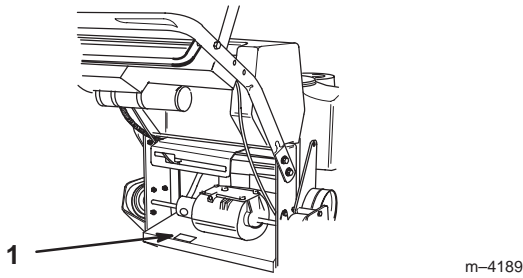

Figure 1

1. Location of the model and serial numbers

Write the product model and serial numbers in the space below:

<p>Model No. _____</p> <p>Serial No. _____</p>
--

This manual identifies potential hazards and has special safety messages that help you and others avoid personal injury and even death. **Danger**, **Warning**, and **Caution** are signal words used to identify the level of hazard. However, regardless of the hazard, be extremely careful.

Danger signals an extreme hazard that *will* cause serious injury or death if you do not follow the recommended precautions.

Warning signals a hazard that *may* cause serious injury or death if you do not follow the recommended precautions.

Caution signals a hazard that may cause minor or moderate injury if you do not follow the recommended precautions.

This manual uses two other words to highlight information. **Important** calls attention to special mechanical information and **Note**: emphasizes general information worthy of special attention.

Safety

This machine meets or exceeds the B71.4 1999 specifications of the American National Standards Institute, in effect at time of production.

Note: The addition of attachments made by other manufacturers that do not meet American National Standards Institute certification will cause noncompliance of this machine.

Improper use or maintenance by the operator or owner can result in injury. To reduce the potential for injury, comply with these safety instructions and always pay attention to the safety alert ⚠ symbol, which means

CAUTION, WARNING, or DANGER—“personal safety instruction.” Failure to comply with the instruction may result in personal injury or death.

Safe Operating Practices

The following instructions are from ANSI standard B71.4—1999.

Training

- Read the Operator’s Manual and other training material. If the operator(s) or mechanic(s) can not read English it is the owner’s responsibility to explain this material to them.
- Become familiar with the safe operation of the equipment, operator controls, and safety signs.
- All operators and mechanics should be trained. The owner is responsible for training the users.
- Never let children or untrained people operate or service the equipment. Local regulations may restrict the age of the operator.
- The owner/user can prevent and is responsible for accidents or injuries occurring to himself or herself, other people or property.

Preparation

- Evaluate the terrain to determine what accessories and attachments are needed to properly and safely perform the job. Only use accessories and attachments approved by the manufacturer.
- Wear appropriate clothing including hard hat, safety glasses and ear protection. Long hair, loose clothing or jewelry may get tangled in moving parts.
- Inspect the area where the equipment is to be used and remove all objects such as rocks, toys and wire which can be thrown by the machine.
- Use extra care when handling gasoline and other fuels. They are flammable and vapors are explosive.
 - Use only an approved container
 - Never remove gas cap or add fuel with engine running. Allow engine to cool before refueling. Do not smoke.
 - Never refuel or drain the machine indoors.
- Check that operator’s presence controls, safety switches and shields are attached and functioning properly. Do not operate unless they are functioning properly.

Operation

- Never run an engine in an enclosed area.
- Only operate in good light, keeping away from holes and hidden hazards.
- Be sure all drives are in neutral and parking brake is engaged before starting engine. Only start engine from the operator's position.
- Slow down and use extra care on hillsides. Be sure to travel side-to-side on hillsides. Turf conditions can affect the machine's stability. Use caution while operating near drop-offs.
- Slow down and use caution when making turns and when changing directions on slopes.
- Never raise deck with the blades running.
- Never operate with the PTO shield, or other guards not securely in place. Be sure all interlocks are attached, adjusted properly, and functioning properly.
- Never operate with the discharge deflector raised, removed or altered, unless using a grass catcher.
- Do not change the engine governor setting or overspeed the engine.
- Stop on level ground, disengage drives, engage parking brake (if provided), shut off engine before leaving the operator's position for any reason including emptying the catchers or unclogging the chute.
- Stop equipment and inspect blades after striking objects or if an abnormal vibration occurs. Make necessary repairs before resuming operations.
- Keep hands and feet away from the cutting unit.
- Look behind and down before backing up to be sure of a clear path.
- Keep pets and bystanders away.
- Slow down and use caution when making turns and crossing roads and sidewalks. Stop blades if not mowing.
- Be aware of the mower discharge direction and do not point it at anyone.
- Do not operate the mower under the influence of alcohol or drugs
- Use care when loading or unloading the machine into or from a trailer or truck
- Use care when approaching blind corners, shrubs, trees, or other objects that may obscure vision.

Maintenance and storage

- Disengage drives, set parking brake, stop engine and remove key or disconnect spark plug wire. Wait for all movement to stop before adjusting, cleaning or repairing.
- Clean grass and debris from cutting unit, drives, mufflers, and engine to help prevent fires. Clean up oil or fuel spillage.
- Let engine cool before storing and do not store near flame.
- Shut off fuel while storing or transporting. Do not store fuel near flames or drain indoors.
- Park machine on level ground. Set parking brake. Never allow untrained personnel to service machine.
- Use jack stands to support components when required.
- Carefully release pressure from components with stored energy.
- Disconnect battery or remove spark plug wire before making any repairs. Disconnect the negative terminal first and the positive last. Reconnect positive first and negative last.
- Use care when checking blades. Wrap the blade(s) or wear gloves, and use caution when servicing them. Only replace blades. Never straighten or weld them.
- Keep hands and feet away from moving parts. If possible, do not make adjustments with the engine running.
- Charge batteries in an open well ventilated area, away from spark and flames. Unplug charger before connecting or disconnecting from battery. Wear protective clothing and use insulated tools.
- Keep all parts in good working condition and all hardware tightened. Replace all worn or damaged decals.

Toro Mower Safety

The following list contains safety information specific to Toro products and other safety information you must know.

This product is capable of amputating hands and feet and throwing objects. Always follow all safety instructions to avoid serious injury or death.

This product is designed for cutting and recycling grass or, when equipped with a grass bagger, for catching cut grass. Any use for purposes other than these could prove dangerous to user and bystanders.

General Operation

- Allow only responsible adults who are familiar with the instructions to operate the machine.
- Be sure the area is clear of other people before mowing. Stop the machine if anyone enters the area.
- Do not mow in reverse unless absolutely necessary. Always look down and behind before and while backing.
- Be aware of the mower discharge direction and do not point it at anyone. Do not operate the mower without either the entire grass catcher or the guard in place.
- Slow down before turning. Sharp turns on any terrain may cause loss of control.
- Turn off blades when not mowing.
- Keep hands, feet, hair and loose clothing away from attachment discharge area, underside of mower and any moving parts while engine is running.
- Stop the engine before removing the grass catcher or unclogging the chute.
- Mow only in daylight or good artificial light.
- Watch for traffic when operating near or crossing roadways.
- Do not touch equipment or attachment parts which may be hot from operation. Allow to cool before attempting to maintain, adjust or service.
- Use only Toro-approved attachments. Warranty may be voided if used with unapproved attachments.

Slope Operation

Slopes and ramps are a major factor related to loss-of-control and accidents, which can result in severe injury or death. All slopes and ramps require extra caution. If you feel uneasy on a slope, do not mow it.

DO

- Remove obstacles such as rocks, tree limbs, etc. from the mowing area. Watch for holes, ruts or bumps. Tall grass can hide obstacles.
- Use slow speed so that you will not have to stop while on the slope.
- Use extra care with grass catchers or other attachments. These can change the stability of the machine.
- Keep all movement on slopes slow and gradual. Do not make sudden changes in speed or direction.
- Avoid starting or stopping on a slope. If tires lose traction, disengage the blades.

- Check carefully for overhead clearances (i.e. branches, doorways, electrical wires) before driving under any objects and do not contact them.
- Mow slopes side-to-side.

DO NOT

- Do not mow slopes greater than 15 degrees.
- Avoid turning on slopes. If you must turn, turn slowly and gradually downhill, if possible.
- Do not mow near drop-offs, ditches, or embankments. The machine could suddenly turn over if a wheel goes over the edge of a cliff or ditch, or if an edge caves in.
- Do not mow on wet grass. Reduced traction could cause sliding.
- Do not use a grass catcher on steep slopes. Heavy grass bags could cause loss of control of the machine.
- Do not mow up and down slopes.

Service

- Never store the machine or fuel container inside where there is an open flame, such as near a water heater or furnace.
- Keep nuts and bolts tight, especially the blade attachment bolts. Keep equipment in good condition.
- Never tamper with safety devices. Check safety systems for proper operation before each use.
- Use only genuine replacement parts to ensure that original standards are maintained.
- Check brake operation frequently. Adjust and service as required.
- Battery acid is poisonous and can cause burns. Avoid contact with skin, eyes and clothing. Protect your face, eyes and clothing when working with a battery.
- Battery gases can explode. Keep cigarettes, sparks and flames away from battery.
- Hydraulic fluid escaping under pressure can penetrate the skin and cause injury. Use cardboard or paper to find hydraulic leaks. Never use your hands.

Slope Chart



Safety and Instruction Decals



Safety decals and instructions are easily visible to the operator and are located near any area of potential danger. Replace any decal that is damaged or lost.



52-2010



82-2280



82-2290



63-8440

1. Hot surface



82-7750



95-2814



98-4387

1. Warning—wear hearing protection.

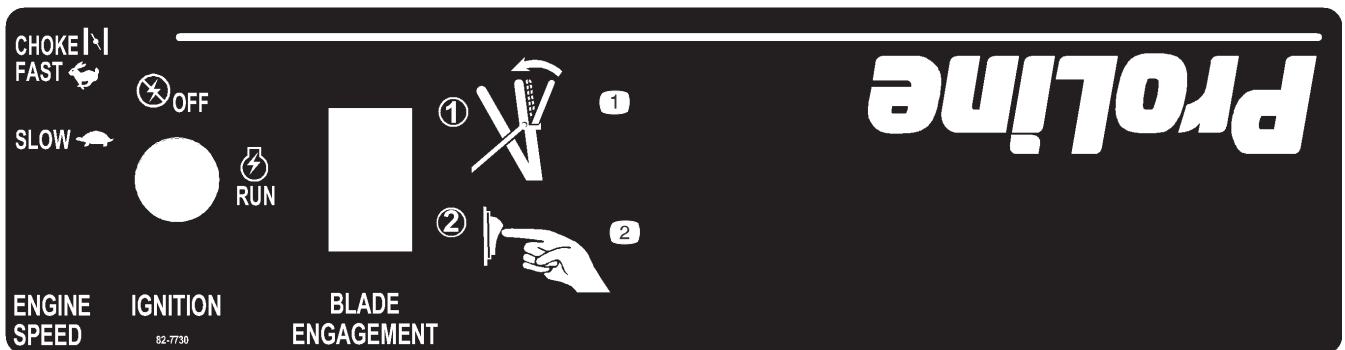

82-7730

1. Squeeze the blade control bail. 2. Press the switch.

⚠ DANGER AVOID SERIOUS INJURY or DEATH:

- DO NOT MOW WHEN CHILDREN OR OTHERS ARE AROUND.
- DO NOT ALLOW OPERATION OF THE MACHINE BY UNTRAINED PERSONNEL.
- KEEP SAFETY DEVICES (GUARDS, SHIELDS, ETC.) IN PLACE & WORKING.
- REMOVE OBJECTS THAT COULD BE THROWN BY THE BLADE.
- READ THE OPERATOR'S MANUAL. FOR REPLACEMENT MANUAL, SEND MODEL AND SERIAL NUMBER TO:
THE TORO CO., 8111 LYNDAL AVE. S., BLOOMINGTON, MN 55420-1196





105-0884

Gasoline and Oil

Recommended Gasoline



Use **Unleaded** Regular Gasoline suitable for automotive use (85 pump octane minimum). Leaded regular gasoline may be used if unleaded regular is not available.

Important Never use methanol, gasoline containing methanol, or gasohol containing more than 10% ethanol because the fuel system could be damaged. Do not mix oil with gasoline.

 **Danger** 

In certain conditions, gasoline is extremely flammable and highly explosive. A fire or explosion from gasoline can burn you and others and can damage property.

- **Fill the fuel tank outdoors, in an open area, when the engine is cold. Wipe up any gasoline that spills.**
- **Never fill the fuel tank inside an enclosed trailer.**
- **Do not fill the fuel tank completely full. Add gasoline to the fuel tank until the level is 1/4 to 1/2 in. (6 to 13 mm) below the bottom of the filler neck. This empty space in the tank allows gasoline to expand.**
- **Never smoke when handling gasoline, and stay away from an open flame or where gasoline fumes may be ignited by a spark.**
- **Store gasoline in an approved container and keep it out of the reach of children. Never buy more than a 30-day supply of gasoline.**
- **Always place gasoline containers on the ground away from your vehicle before filling.**
- **Do not fill gasoline containers inside a vehicle or on a truck or trailer bed because interior carpets or plastic truck bed liners may insulate the container and slow the loss of any static charge.**
- **When practical, remove gas-powered equipment from the truck or trailer and refuel the equipment with its wheels on the ground.**
- **If this is not possible, then refuel such equipment on a truck or trailer from a portable container, rather than from a gasoline dispenser nozzle.**
- **If a gasoline dispenser nozzle must be used, keep the nozzle in contact with the rim of the fuel tank or container opening at all times until fueling is complete.**

 **Warning** 

Gasoline is harmful or fatal if swallowed. Long-term exposure to vapors can cause serious injury and illness.

- **Avoid prolonged breathing of vapors.**
- **Keep face away from nozzle and gas tank or conditioner opening.**
- **Keep gas away from eyes and skin.**

Using Stabilizer/Conditioner

Use a fuel stabilizer/conditioner in the machine to provide the following benefits:

- Keeps gasoline fresh during storage of 90 days or less. For longer storage it is recommended that the fuel tank be drained.
- Cleans the engine while it runs
- Eliminates gum-like varnish buildup in the fuel system, which causes hard starting

Important Do not use fuel additives containing methanol or ethanol.

Add the correct amount of gas stabilizer/conditioner to the gas.

Note: A fuel stabilizer/conditioner is most effective when mixed with fresh gasoline. To minimize the chance of varnish deposits in the fuel system, use fuel stabilizer at all times.

Filling the Fuel Tank

1. Shut the engine off and set the parking brake.
2. Clean around fuel tank cap and remove the cap. Add unleaded regular gasoline to fuel tank, until the level is 1/4 to 1/2 inch (6 to 13 mm) below the bottom of the filler neck. This space in the tank allows gasoline to expand. Do not fill the fuel tank completely full.
3. Install fuel tank cap securely. Wipe up any gasoline that may have spilled.

Check Engine Oil Level

Before you start the engine and use the machine, check the oil level in the engine crankcase; refer to Checking the Engine Oil Level, page 23.

Setup

Note: Determine the left and right sides of the machine from the normal operating position.

Loose Parts

Note: Use the chart below to verify all parts have been shipped.

DESCRIPTION	QTY.	USE
Shift lever	1	Installing the shift lever
Shift lever mounting bracket	1	
Washer, 1/4 in.	1	
Bolt, 1/4 x 2 in.	1	
Fuel tank	1	Installing the control panel and fuel tank
Control panel	1	
Bolt, 5/16 x 7/8 in.	4	
Lock washer, 5/16 in.	4	
Washer, 5/16 in.	4	
Hose clamp	2	
Upper handle	1	Installing the upper handle
Flanged bolt, 3/8 x 1 in.	4	
Flange nut, 3/8 in.	4	
Screw self-tapping	1	Installing the wire harness
Star washer	1	
Wire tie	1	
Rod fitting	2	Installing the control rods
Clevis pin	2	
Washer, 1/4 in.	2	
Hairpin cotter	2	
Operator's Manual	1	Read before operating machine
Engine Operator's Manual	1	
Parts Catalog	1	
Registration card	1	Fill out and return to Toro

Installing the Shift Lever

1. Align mounting block with flats of shaft on top of transmission and slide onto shaft (Fig. 2).

2. Align mounting hole in lever with mounting block on transmission. Secure lever to transmission with 2 in. (51 mm) bolt and washer. Torque bolt to 115 in.-lb. (13 N.m).

Note: Do not remove rubber washer on transmission shaft.

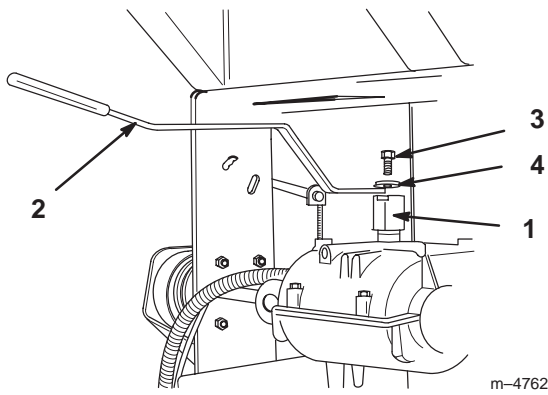

Figure 2

- | | |
|-------------------|----------------------|
| 1. Mounting block | 3. Bolt, 1/4 x 2 in. |
| 2. Shift lever | 4. Washer |

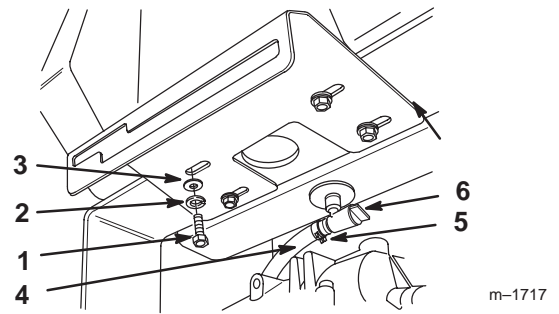

Figure 4

- | | |
|------------------------|-----------------|
| 1. Bolt, 5/8 x 7/8 in. | 4. Fuel line |
| 2. Lock washer | 5. Hose clamp |
| 3. Washer | 6. Fuel fitting |

Installing the Control Panel and Fuel Tank

- Slide control panel over shift lever and under bottom of rear frame (Fig. 3). Align fuel tank to top of rear frame (Fig. 3).

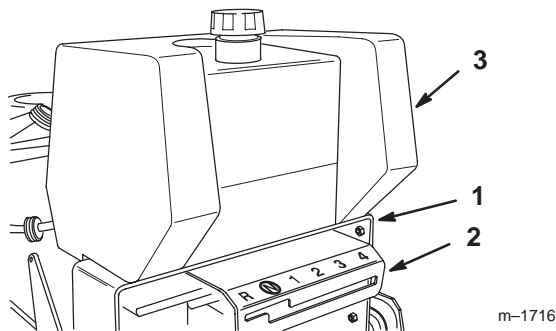

Figure 3

- | | |
|------------------|--------------|
| 1. Rear frame | 3. Fuel tank |
| 2. Control panel | |

- Secure control panel and fuel tank to rear frame with 4 bolts (5/16 x 7/8 in.), 4 lock washers (5/16 in.) and washers (Fig. 4).
- Slide hose clamp onto fuel line (Fig. 4). Push fuel line onto fuel tank fitting and secure with hose clamp (Fig. 4).

- Shift lever to second gear and check alignment of lever in shifter plate slot. The clearance between top and bottom of the shift lever should be equal (Fig. 5).

- If clearance is not correct, remove lever and bend it slightly to adjust (Fig. 2).

Note: Do not bend lever while attached to transmission shaft or damage may occur.

- Shift lever to neutral and check alignment of lever in slot of shifter plate. The clearance on the sides of shift lever should be equal (Fig. 5).

- If clearance is not correct, loosen control panel and adjust it side-to-side. Tighten the control panel.

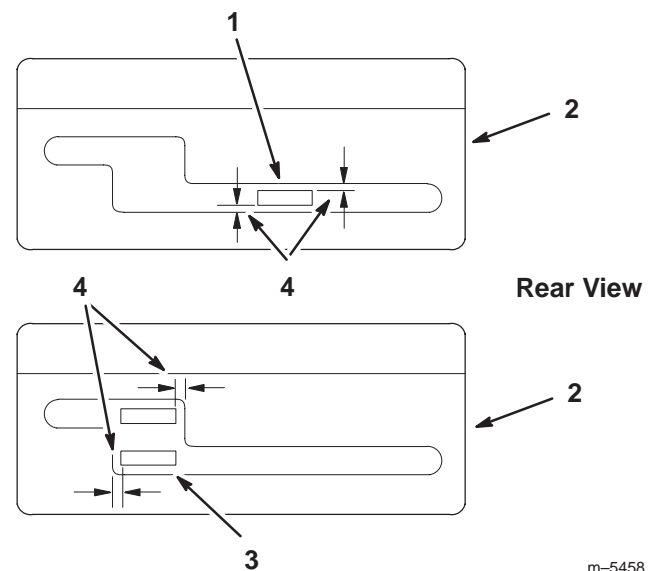

Figure 5

- | | |
|--------------------------------------|-------------------------|
| 1. Shift lever, 2 nd gear | 3. Shift lever, neutral |
| 2. Control panel | 4. Equal distance |

Installing the Upper Handle

1. Align upper handle with upper mounting holes in rear frame (Fig. 6).
2. Secure each upper mounting hole with a flange bolt (3/8 x 1 in.) and flange nut (Fig. 6). Torque bolts to 25 ft.-lb. (34 N•m).
3. Select high, medium or low position for the lower mounting hole (Fig. 6). This allows the upper handle to be adjusted to the user's height preference.
4. Secure each lower mounting hole with a flange bolt (3/8 x 1 in.) and flange nut (Fig. 6). Torque bolts to 25 ft.-lb. (34 N•m).

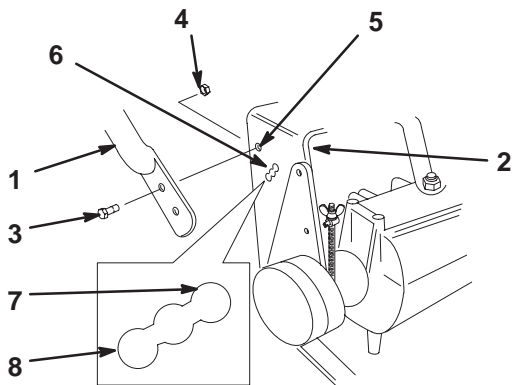

Figure 6

- | | |
|-----------------------------|-------------------------|
| 1. Upper handle | 5. Upper mounting hole |
| 2. Rear frame | 6. Lower mounting holes |
| 3. Flange bolt, 3/8 x 1 in. | 7. Low position |
| 4. Flange nut, 3/8 in. | 8. High position |

m-5317

Connecting the Throttle Cable

1. Route engine speed control cable around left side of engine.
2. Place throttle control in the fast position.
3. Hook wire Z-bend into speed control lever on engine (Fig. 7).
4. Loosen cable clamp bolt and insert cable, but do not tighten (Fig. 7).
5. Align the hole in the speed control lever with the hole in the base plate (Fig. 7) by moving the lever. Insert a 1/4 in. (6 mm) diameter pin or bolt through two holes.
6. Pull up the outer housing of the throttle cable until the inner wire has almost no slack, and tighten the cable clamp bolt (Fig. 7). Remove the 1/4 in. (6 mm) diameter pin or bolt.

Note: Make sure that the carburetor choke valve (Fig. 8) is closed completely when the throttle lever is moved to the choke position. If not, refer to Adjusting the Choke; page 15.

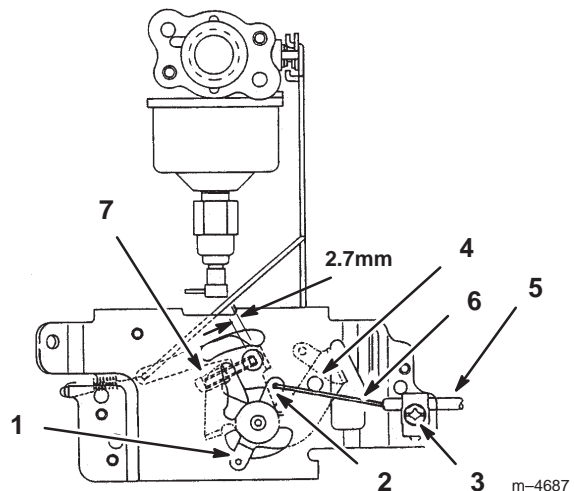
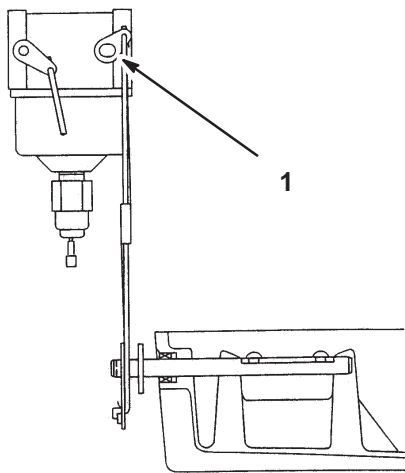

Figure 7

- | | |
|------------------------|---------------------------------|
| 1. Speed control lever | 5. Throttle cable outer housing |
| 2. Z-bend in wire | 6. Throttle cable inner wire |
| 3. Cable clamp bolt | 7. Choke setting screw |
| 4. Align holes | |

m-4687



m-4712

Figure 8

1. Carburetor choke valve

Adjusting the Choke

1. Place throttle control in the choke position.
2. Align the hole in the speed control lever with the hole in the base plate (Fig. 7) by moving the lever. Insert a 1/4 in. (6 mm) diameter pin or through two holes.
3. Turn the choke setting screw so that the clearance between the screw end and the tongue of the lever is .11 in. (2.7 mm) (Fig. 7). Remove the 1/4 in. (6 mm) diameter pin or bolt.

Note: Make sure that the choke valve turns from fully closed position to fully opened position when moving throttle control to fast position.

Connecting the Wire Harness

1. Route wire harness along inside of left handle bracket.
2. Plug clutch wire into connector (Fig. 9).
3. Secure the black ground wire to engine mount with a nut (5/16 in.) (Fig. 9).
4. Secure wire harness to upper handle with cable tie.

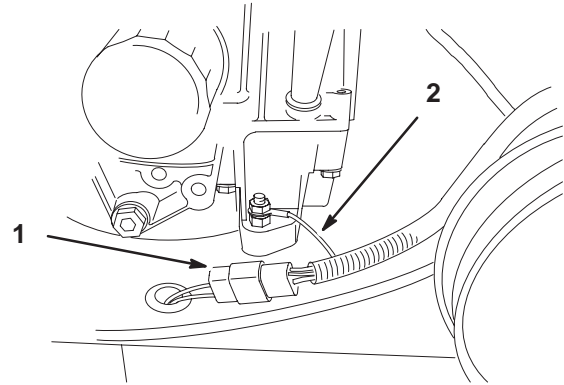

m-4713

Figure 9

1. Clutch wire connector
2. Ground wire

5. Route the other part of the wire harness around to the right side of the engine and secure with clamp and nut on engine base (Fig. 10).
6. Push the two wires together (Fig. 10).

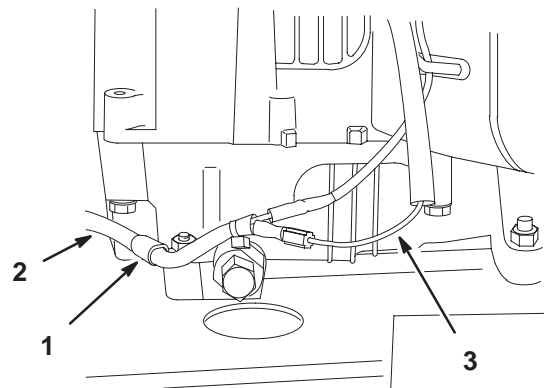

m-4688

Figure 10

1. Clamp and nut
2. Wire harness
3. Engine wire

Installing the Control Rods

1. Thread rod fittings equal distance onto each control rod. For a starting point thread on approximately 2 in. (51 mm) (Fig. 11).
2. Slide clevis pins through rod fittings and mounting holes in idler brackets (from outside) (Fig. 11). Secure with washers and hairpin cotters (Fig. 11).

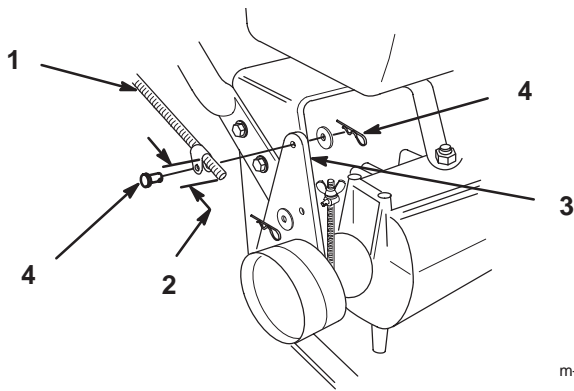

Figure 11

- | | |
|----------------------------|--|
| 1. Control rod and fitting | 4. Clevis pin, washer and hairpin cotter |
| 2. 2 in. (51 mm) | |
| 3. Idler bracket | |

3. Check the gap between upper control bar and fixed bar with wheel drive fully engaged. Gap should be approximately 1 to 1-1/4 in. (25–32 mm) (Fig. 12).

Note: The upper control bar and fixed bar must be parallel when in engaged, drive, relaxed and brake positions.

4. Check operation. If adjustment is required, remove hairpin cotter securing rod to upper control bar. Thread rod in or out of fitting for proper position and install into upper control bar with hairpin cotter.

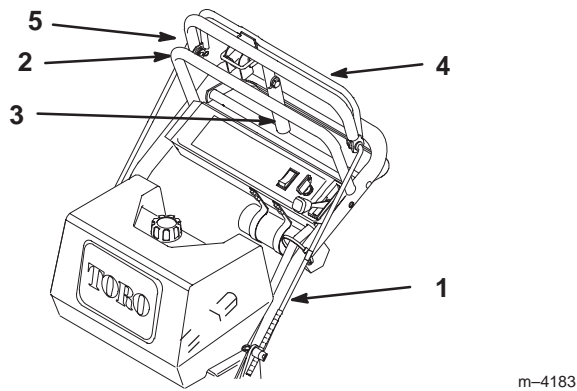

Figure 12

- | | |
|------------------------|------------------------------|
| 1. Control rod | 4. Upper control bar |
| 2. Fixed control bar | 5. 1 to 1-1/4 in. (25–32 mm) |
| 3. Parking brake lever | |

5. Check parking brake adjustment. Brake rods should be adjusted so parking brake lever is tight when swung into position against the fixed bar while pulling back on upper control bar (Fig. 13).

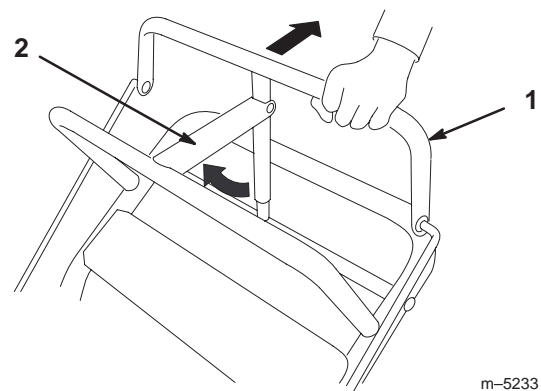

Figure 13

- | | |
|----------------------|------------------------|
| 1. Upper control bar | 2. Parking brake lever |
|----------------------|------------------------|

6. If brake adjustment is required, remove hairpin cotter and washer securing brake rod fitting to idler bracket (Fig. 14).

7. Adjust wing nut up or down on brake rod and secure fitting to idler bracket (Fig. 14). Check adjustment and readjust if necessary.

Note: Make sure brake rod is installed in front (F) mounting hole in idler bracket.

8. Repeat procedure on opposite side if adjustment is required to keep control bar and fixed bar.

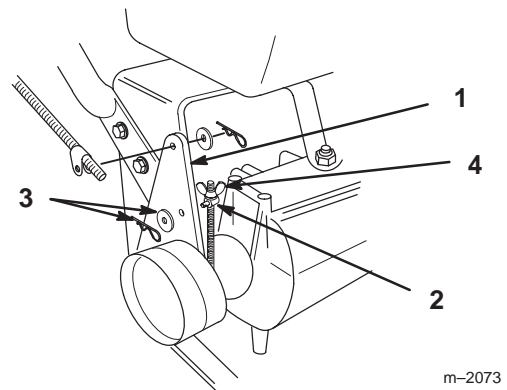

Figure 14

- | | |
|----------------------|------------------------------|
| 1. Idler bracket | 3. Hairpin cotter and washer |
| 2. Brake rod fitting | 4. Wing nut |

Operation

Note: Determine the left and right sides of the machine from the normal operating position.

2. Lift the parking brake lock (Fig. 17) up and gradually release the upper control bar. The brake lock should stay in the set (locked) position.

Releasing the Parking Brake

1. Pull rearward on the upper control bar (Fig. 17). Lower the parking brake lock to the released position.
2. Gradually release the upper control bar.

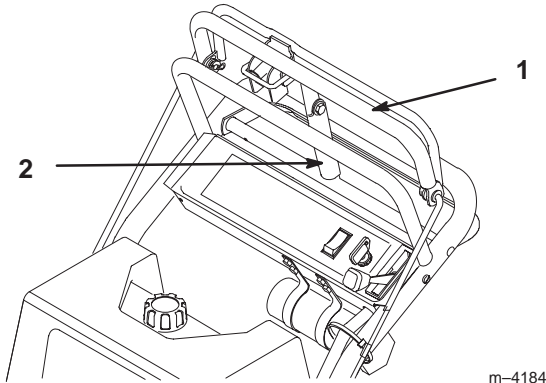

Figure 17

1. Upper control bar
2. Parking brake lock

Stopping the Engine

1. Move the throttle lever to slow (Fig. 18).

Note: If the engine has been working hard or is hot, let it idle for a minute before turning the ignition key off. This helps cool the engine before it is stopped. In an emergency, the engine may be stopped by turning the ignition key to off.

2. Turn the ignition key to off. (Fig. 18).

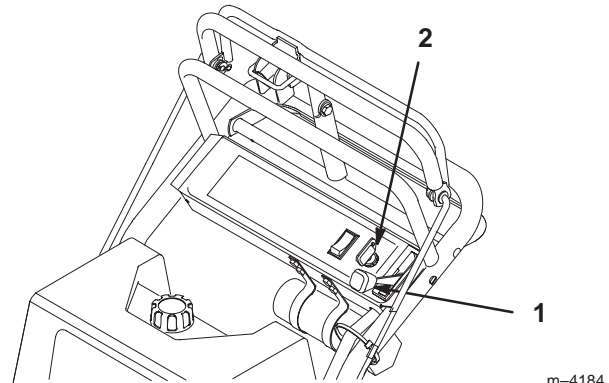

Figure 18

1. Throttle lever
2. Ignition key

Starting and Stopping the Engine

Starting the Engine

1. Make sure spark plug wire(s) are installed on spark plug(s) and fuel valve is open.
2. Move the shift lever to neutral, set the parking brake and turn ignition key to the run position.
3. Move the throttle control to the choke position before starting a cold engine.

Note: A warm or hot engine usually does not require any choking. To start a warm engine, move throttle control to the fast position.

4. Grasp recoil starter handle firmly and pull out until positive engagement results; then pull handle vigorously to start engine and allow rope to recoil slowly.

Important Do not pull recoil rope to its limit or let go of the starter handle when rope is pulled out because rope may break or recoil assembly may be damaged.

3. Set the parking brake.
4. Pull wire off spark plug(s) to prevent possibility of accidental starting before storing machine.
5. Close fuel shut off valve before storing machine.

Important Make sure fuel shut off valve is closed before transporting or storing machine, as fuel leakage may occur.

Operating the Mower Blade Control (PTO)

The blade control switch (PTO) in conjunction with the blade control bail engages and disengages power to the electric clutch and mower blades.

Engaging the Mower Blades (PTO)

1. Pull on the upper control bar to stop the machine (Fig. 19).
2. To engage blade, squeeze blade control bail against upper control bar
3. Press rocker switch forward to on and release. Hold blade control bail against control bar while operating.

- Repeat procedure to engage mower blades if blade control bail is released.

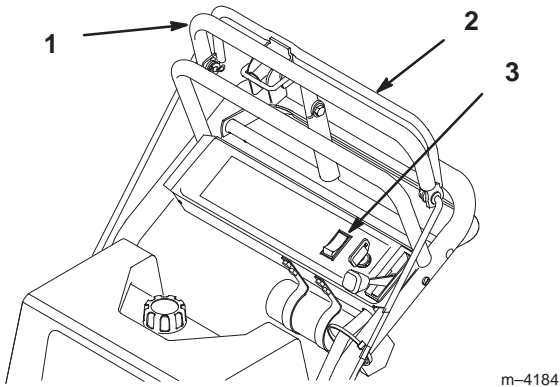

Figure 19

- | | |
|-----------------------|-------------------------------|
| 1. Upper control bar | 3. Blade control switch (PTO) |
| 2. Blade control bail | |

Disengaging the Mower Blades (PTO)

- Releasing blade control bail to disengage blades (PTO) (Fig. 19).

The Safety Interlock System

⚠
Caution
⚠

If safety interlock switches are disconnected or damaged the machine could operate unexpectedly causing personal injury.

- **Do not tamper with the interlock switches.**
- **Check the operation of the interlock switches daily and replace any damaged switches before operating the machine.**

Understanding the Safety Interlock System

The safety interlock system is designed to prevent the mower blades from rotating unless:

- The control bail is depressed.
- The blade control switch (PTO) is pressed on.

The safety interlock system is designed to stop the mower blades if you released the blade control bail.

Testing the Safety Interlock System

Test the safety interlock system before you use the machine each time. If the safety system does not operate as described below, have an Authorized Service Dealer repair the safety system immediately.

- Set the parking brake and start the engine :refer to Starting and Stopping the Engine, page 18
- Squeeze the blade control bail against upper control bar. The blades should not rotate.
- Then continue holding the blade control bail and press the rocker switch forward to on and release. The clutch should engage and the mower blades begin rotating.
- Release the blade control bail. The blades should stop rotating.
- Then push the blade control switch (PTO) to on without holding the blade control bail. The blades should not rotate.

Driving Forward or Backward

The throttle control regulates the engine speed as measured in rpm (revolutions per minute). Place the throttle control in the fast position for best performance.

Driving Forward

- To go forward, move the shift lever to a forward gear.
- Release the parking brake: refer to Releasing the Parking Brake, page 18.
- Slowly press on the upper control bar to move forward (Fig. 20).

To go straight, apply equal pressure to both ends of the upper control bar (Fig. 20).

To turn, release pressure on the upper control bar side away from the direction you want to turn (Fig. 20).

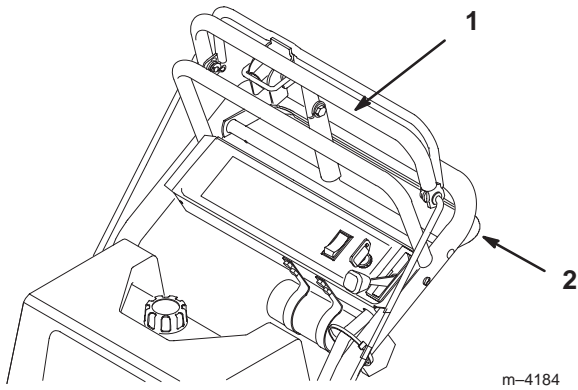

Figure 20

1. Upper control bar
2. Lower control bar

Driving Backward

1. To go backward, move the shift lever to reverse gear.
2. Release the parking brake; refer to Releasing the Parking Brake, page 18.
3. Slowly squeeze the lower control bar and handle together to move rearward (Fig. 20).

Operating the Lower Control Bar

This procedure is for driving up a curb. This can be performed while driving forward or backward.

1. Disengage the mower blades.

Warning

A blade can be bent or damaged when driving up a curb. Pieces of blade that may be thrown could seriously injure or kill you or bystanders.

- **Do not run blades while driving up a curb forward or backward.**

2. Select first gear or reverse to drive machine.
3. Drive machine until drive wheels contact curb (Fig. 22).

Note: Both drive wheels should contact the curb and caster wheels straight.

4. At the same time engage lower control bar and lift up on handle (Figures 21 and 22).

Note: Lifting up on handle will assist driving the machine up a curb and not spin the drive wheels.

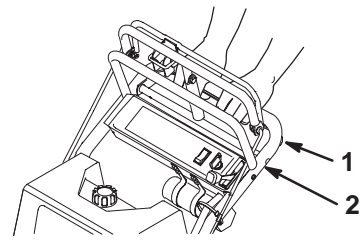

Figure 21

1. Lower Control Bar (Engaged)
1. Handle

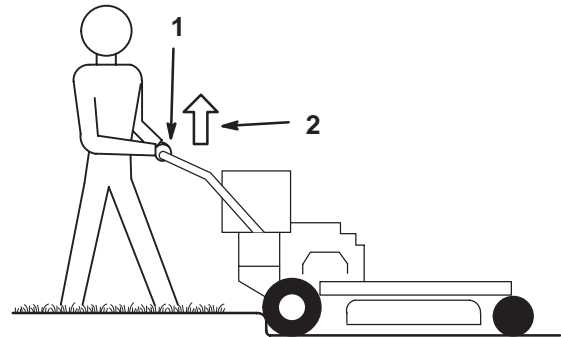

Figure 22

1. Lower Control Bar engaged and mower in reverse.
2. Pull up to assist machine in reverse.

Stopping the Machine

To stop the machine, pull back on the upper control bar, release the blade control bail (PTO), and turn the ignition key to off. Also set the parking brake if you leave the machine unattended; refer to Setting the Parking Brake, page 17. Remember to remove the key from the ignition switch.

Caution

Children or bystanders may be injured if they move or attempt to operate the tractor while it is unattended.

Always remove the ignition and set the parking brake when leaving the machine unattended, even if just for a few minutes.

Maintenance



Note: Determine the left and right sides of the machine from the normal operating position.

Recommended Maintenance Schedule

Maintenance Service Interval	Maintenance Procedure
Each Use	<ul style="list-style-type: none"> • Oil—check level • Safety system—check • Brake—check • Engine—clean outside
5 Hours	<ul style="list-style-type: none"> • Wheel bearings—grease¹
After First 8 Hours	<ul style="list-style-type: none"> • Oil—change
25 Hours	<ul style="list-style-type: none"> • Foam air cleaner—service¹
50 Hours	<ul style="list-style-type: none"> • Belts—check for wear/cracks • Tires—check pressure
100 Hours	<ul style="list-style-type: none"> • Oil—change¹ • Electric clutch—adjust • Engine—clean outside • Spark plug(s)—check • Paper air cleaner—clean¹
200 Hours	<ul style="list-style-type: none"> • Fuel filter—replace • Oil filter—change (200 hours or every other oil change) • Transmission couplings—grease¹
300 Hours	<ul style="list-style-type: none"> • Paper air cleaner—replace¹
At storage	<ul style="list-style-type: none"> • Chipped surfaces—paint • Perform all maintenance procedures listed above before storage

¹More often in dusty, dirty conditions.

Important Refer to your engine operator's manual for additional maintenance procedures.

 Caution 
<p>If you leave the key in the ignition switch, someone could accidentally start the engine and seriously injure you or other bystanders.</p> <p>Remove the key from the ignition and disconnect the wire from the spark plug(s) before you do any maintenance. Set the wire aside so that it does not accidentally contact the spark plug.</p>

Servicing the Air Cleaner

Service Interval/Specification

Foam Element: Clean and re-oil after every 25 operating hours.

Paper Element: Clean after every 100 operating hours.
Replace after every 300 operating hours or yearly, whichever ever occurs first.

Note: Service the air cleaner more frequently (every few hours) if operating conditions are extremely dusty or sandy.

Removing the Foam and Paper Elements

1. Disengage the power take off (PTO), set the parking brake, and turn the ignition key to off. Remove the key.
2. Clean around the air cleaner to prevent dirt from getting into the engine and causing damage. Pull out on retaining latches and remove the air cleaner cover (Fig. 23).
3. Unscrew nut and remove the air cleaner assembly (Fig. 23).
4. Carefully pull the foam element off the paper element (Fig. 23).

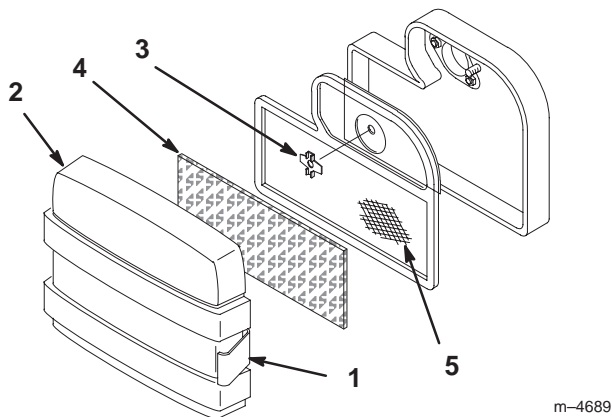

Figure 23

- | | |
|--------------------|------------------|
| 1. Retaining latch | 4. Foam element |
| 2. Cover | 5. Paper element |
| 3. Nut | |

Cleaning the Foam Element

1. Wash the foam element in liquid soap and warm water. When the element is clean, rinse it thoroughly.
2. Dry the element by squeezing it in a clean cloth.
3. Put one or two ounces of oil on the element (Fig. 24). Squeeze the element to distribute the oil.

Important Replace the foam element if it is torn or worn.

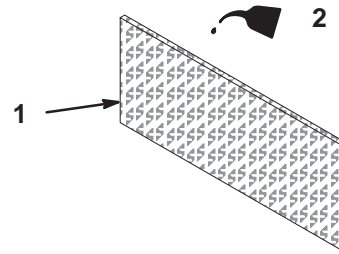

Figure 24

- | | |
|-----------------|--------|
| 1. Foam element | 2. Oil |
|-----------------|--------|

Cleaning the Paper Elements

1. Lightly tap the element on a flat surface to remove dust and dirt (Fig. 25).
2. Inspect the element for tears, an oily film, and damage to the rubber seal.

Important Never clean the paper element with pressurized air or liquids. Replace the paper element if it is damaged, defective, or cannot be cleaned thoroughly.

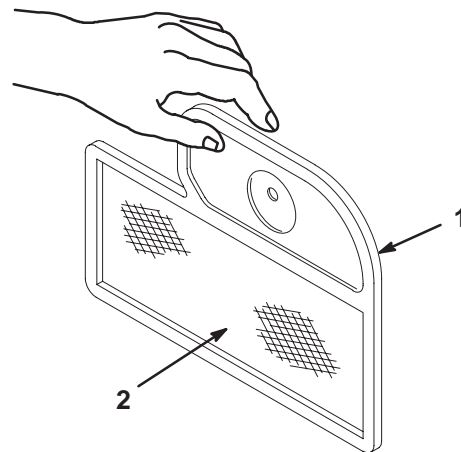

Figure 25

- | | |
|------------------|----------------|
| 1. Paper element | 2. Rubber seal |
|------------------|----------------|

Installing the Foam and Paper Elements

Important To prevent engine damage, always operate the engine with the complete foam and paper air cleaner assembly installed.

1. Carefully place the foam element onto the paper air cleaner element (Fig. 23).
2. Place the air cleaner assembly onto the air cleaner base (Fig. 23). Secure with nut.

3. Install the air cleaner cover and secure latches (Fig. 23).

Servicing the Engine Oil

Service Interval/Specification

Change oil:

- After the first 8 operating hours.
- After every 100 operating hours.

Note: Change oil more frequently when operating conditions are extremely dusty or sandy.

Oil Type: Detergent oil (API service SE, SF, SG or SH)

Crankcase Capacity: w/filter, 61 oz. (1.8 l)

Viscosity: See table below

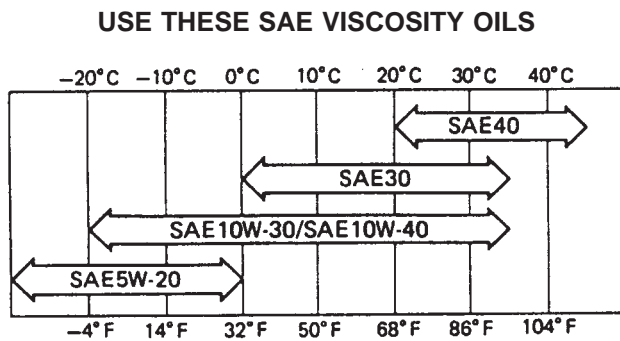

m-4292

Checking the Engine Oil Level

1. Park the machine on a level surface, disengage the power take off (PTO), set the parking brake, and turn the ignition key to off. Remove the key.
2. Clean around the oil dipstick (Fig. 26) so dirt cannot fall into the filler hole and damage the engine.
3. Unscrew the oil dipstick and wipe the metal end clean (Fig. 26).
4. Thread the oil dipstick fully onto the filler tube (Fig. 26). Pull the dipstick out and look at the metal end. If oil level is low, slowly pour only enough oil into the filler tube to raise the level to the full mark.

Important Do not overfill the crankcase with oil because the engine may be damaged.

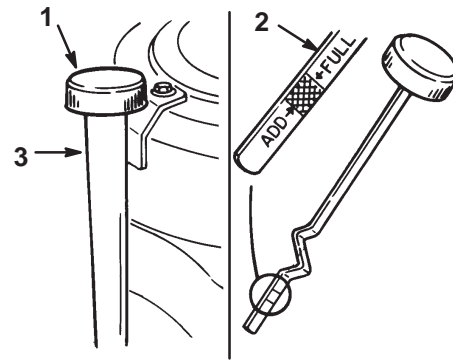

Figure 26

1. Oil dipstick
2. Metal end
3. Filler tube

Changing the Engine Oil

1. Start the engine and let it run five minutes. This warms the oil so it drains better.
2. Park the machine so that the drain side is slightly lower than the opposite side to assure the oil drains completely. Then disengage the power take off (PTO), set the parking brake, and turn the ignition key to off. Remove the key.
3. Place a pan below the oil drain. Remove the oil drain cap (Fig. 27).
4. When oil has drained completely, install the oil drain cap.

Note: Dispose of the used oil at a certified recycling center.

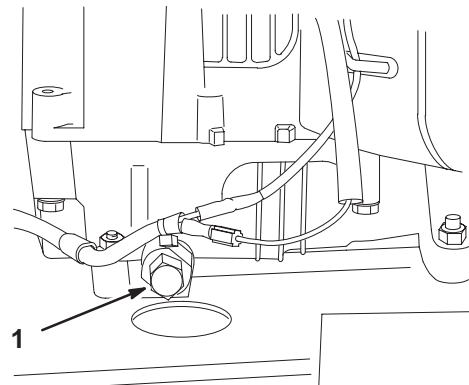

Figure 27

1. Oil drain cap

5. Slowly pour approximately 80% of the specified oil, on page 23, into the filler cap (Fig. 26). Now check the oil level; refer to Checking the Engine Oil Level, page 23. Slowly add additional oil to bring it to the full mark.

Change the Engine Oil Filter

Service Interval/Specification

Replace the oil filter every 200 hours or every other oil change.

Note: Change oil filter more frequently when operating conditions are extremely dusty or sandy.

1. Drain the oil from the engine; refer to Changing the Engine Oil, page 23.
2. Remove the old filter (Fig. NO TAG).
3. Apply a thin coat of new oil to the rubber gasket on the replacement filter (Fig. 28).
4. Install the replacement oil filter to the filter adapter. Turn the oil filter clockwise until the rubber gasket contacts the filter adapter, then tighten the filter an additional 3/4 turn (Fig. 28).

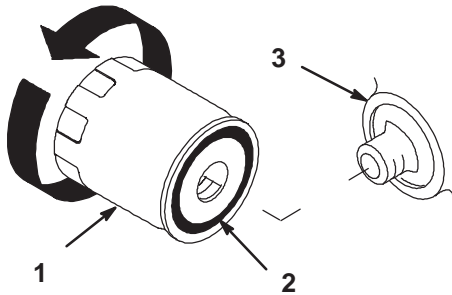

m-1256

Figure 28

1. Oil filter
2. Gasket
3. Adapter

5. Fill the crankcase with the proper type of new oil; refer to Changing the Engine Oil, page 23.

Servicing the Spark Plug

Service Interval/Specification

Check the spark plug(s) after every 100 operating hours. Make sure the air gap between the center and side electrodes is correct before installing the spark plug. Use a spark plug wrench for removing and installing the spark plug(s) and a gapping tool/feeler gauge to check and adjust the air gap. Install a new spark plug(s) if necessary.

Type: Champion RCJ8Y or equivalent

Air Gap: 0.040 in. (1.00 mm)

Removing the Spark Plug(s)

1. Disengage the power take off (PTO), set the parking brake, and turn the ignition key to off. Remove the key.
2. Pull the wire(s) off the spark plug(s) (Fig. 29). Now clean around the spark plug(s) to prevent dirt from falling into the engine and potentially causing damage.
3. Remove the spark plug(s).

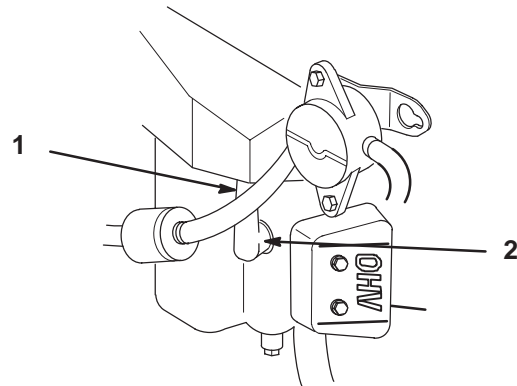

M-4294

Figure 29

1. Spark plug wire installed
2. Spark plug

Checking the Spark Plug

1. Look at the center of the spark plug(s) (Fig. 30). If you see light brown or gray on the insulator, the engine is operating properly. A black coating on the insulator usually means the air cleaner is dirty.

Important Never clean the spark plug(s). Always replace the spark plug(s) when it has: a black coating, worn electrodes, an oily film, or cracks.

2. Check the gap between the center and side electrodes (Fig. 30). Bend the side electrode if the gap is not correct (Fig. 30).

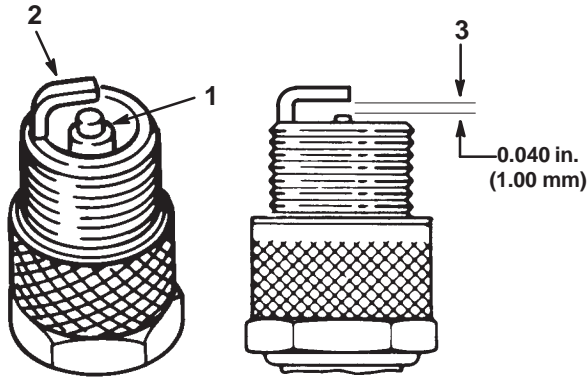

Figure 30

1. Center electrode insulator
2. Side electrode
3. Air gap (not to scale)

Installing the Spark Plug(s)

1. Install the spark plug(s). Make sure the air gap is set correctly.
2. Tighten the spark plug(s) to 11 ft.-lb. (15 N•m).
3. Push the wire(s) onto the spark plug(s) (Fig. 29).

Greasing and Lubrication

Service Interval/Specification

Grease the wheel bearings every 8 operating hours and the transmission couplers every 200 operating hours. Grease more frequently when operating conditions are extremely dusty or sandy.

Grease Type: General-purpose grease.

How to Grease

1. Disengage the power take off (PTO), set the parking brake, and turn the ignition key to off. Remove the key.

2. Clean the grease fittings with a rag. Make sure to scrape any paint off the front of the fitting(s).
3. Connect a grease gun to the fitting. Pump grease into the fittings until grease begins to ooze out of the bearings.
4. Wipe up any excess grease.

Where to Add Grease

1. Lubricate the wheel bearings and front spindles until grease begins to ooze out of the bearings (Fig. 31).

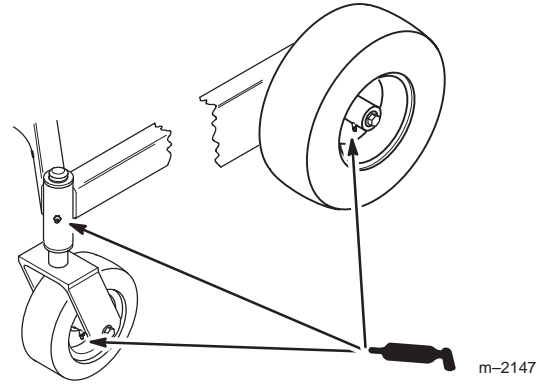

Figure 31

2. Lubricate the transmission couplers (Fig. 32).

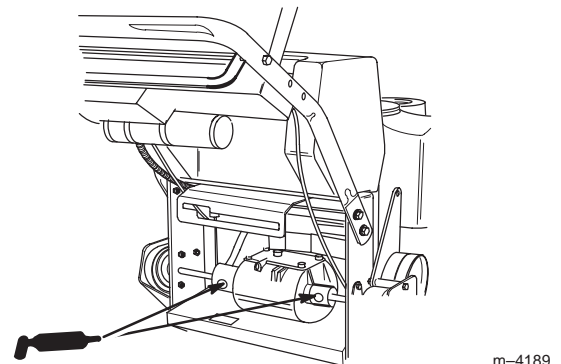

Figure 32

Cleaning the Cooling System

Service Interval/Specification

Before each use, check and clean engine cooling system. Remove any build-up of grass, dirt or other debris from the cylinder and cylinder head cooling fins, air intake screen on flywheel end, and carburetor-governor levers and linkage. This will help insure adequate cooling and correct engine speed and will reduce the possibility of overheating and mechanical damage to the engine.

Checking the Tire Pressure

Service Interval/Specification

Maintain the air pressure in the front and rear tires as specified. Check the pressure at the valve stem after every 50 operating hours or monthly, whichever occurs first (Fig. 33). Check the tires when they are cold to get the most accurate pressure reading.

Pressure: 15 psi (103 kPa) rear tires
25–30 psi (172–207 kPa) caster tires

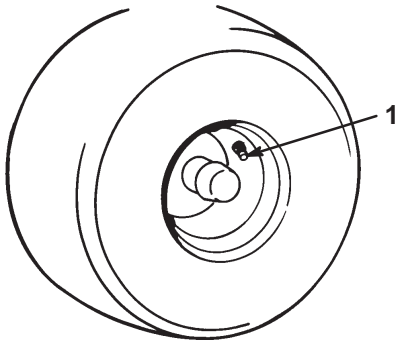

Figure 33
1. Valve stem

Servicing the Brake

Service Interval/Specification

Before each use, check brakes for proper operation.

Always set the parking brake when you stop the machine or leave it unattended. If the parking brake does not hold securely, an adjustment is required.

Checking the Brake

1. Park the machine on a level surface, disengage the power take off (PTO), set the parking brake, and turn the ignition key to off. Remove the key.
2. Rear wheels must lock when you try to push the machine forward. Adjustment is required if the wheels turn and do not lock; refer to Adjusting the Brake, page 26.
3. Release the brake and press upper control bar very lightly, approximately 1/2 in. (13 mm), wheels should rotate freely.
4. If both conditions are met no adjustment is required.

Adjusting the Brake

The brake lever is on the upper control bar (Fig. 16). If the parking brake does not hold securely, an adjustment is required.

1. Check the brake before you adjust it; refer to Checking the Brake, page 26.
2. Release the parking brake; refer to Releasing the Parking Brake, page 18.
3. To adjust the brake remove the cotter pin and washer from the brake lever (Fig. 34).
4. Rotate the trunnion so it smoothly slides into brake lever (Fig. 34). Tighten wing nut.
5. Secure trunnion to brake lever with washer and cotter pin (Fig. 34).
6. Check the brake operation again; refer to Checking the Brake, page 26.

Important With the parking brake released, the rear wheels must rotate freely when you push the mower. If brake action and free wheel rotation cannot be achieved contact your service dealer immediately.

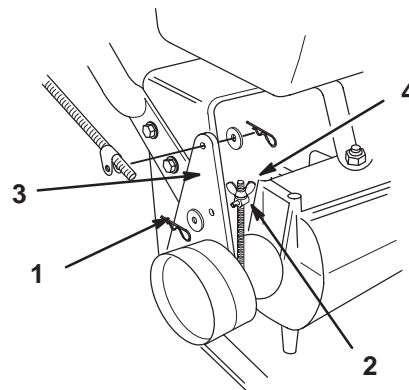

Figure 34

- | | |
|------------------------------|----------------|
| 1. Hairpin cotter and washer | 3. Brake lever |
| 2. Trunnion | 4. Wing nut |

m-2073

Servicing the Fuel Tank

Draining The Fuel Tank

! **Danger** !

In certain conditions, gasoline is extremely flammable and highly explosive. A fire or explosion from gasoline can burn you and others and can damage property.

- Drain gasoline from the fuel tank when the engine is cold. Do this outdoors in an open area. Wipe up any gasoline that spills.
- Never smoke when draining gasoline, and stay away from an open flame or where a spark may ignite the gasoline fumes.

1. Park the machine on a level surface, to assure fuel tank drains completely. Then disengage the power take off (PTO), set the parking brake, and turn the ignition key to off. Remove the key.
2. Close fuel shut-off valve at fuel tank (Fig. 35).
3. Squeeze the ends of the hose clamp together and slide it up the fuel line away from valve (Fig. 35).
4. Pull the fuel line off the valve (Fig. 35). Open fuel shut-off valve and allow gasoline to drain into a gas can or drain pan.

Note: Now is the best time to install a new fuel filter because the fuel tank is empty. Refer to Replacing the Fuel Filter; page 27.

5. Install the fuel line onto the valve. Slide the hose clamp close to the valve to secure the fuel line.

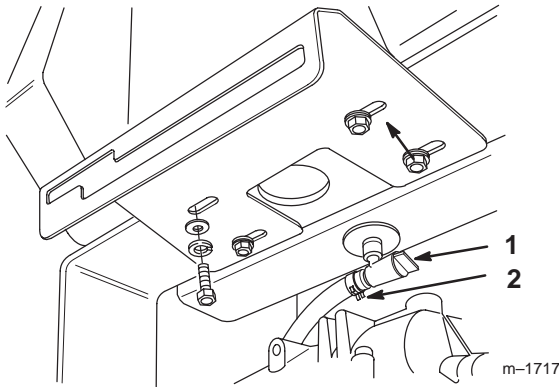

Figure 35

1. Fuel shut-off valve
2. Clamp

Servicing the Fuel Filter

Service Interval/Specification

Replace the fuel filter after every 200 operating hours or yearly, whichever occurs first.

Replacing the Fuel Filter

Never install a dirty filter if it is removed from the fuel line.

1. Disengage the power take off (PTO), set the parking brake, and turn the ignition key to off. Remove the key.
2. Close fuel shut-off valve at fuel tank (Fig. 35).
3. Squeeze the ends of the hose clamps together and slide them away from the filter (Fig. 36).

4. Remove the filter from the fuel lines.
5. Install a new filter and move the hose clamps close to the filter.
6. Open fuel shut-off valve at fuel tank (Fig. 35).

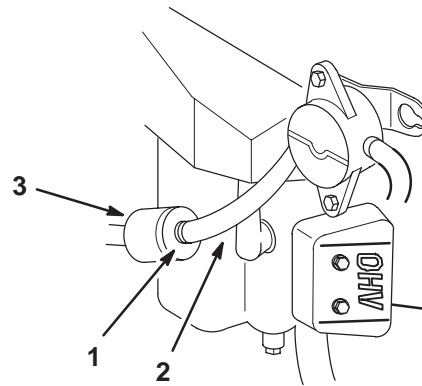

Figure 36

1. Hose clamp
2. Fuel line
3. Filter

Replacing the Drive Belt

Service Interval/Specification

Check all belts after every 50 operating hours or monthly, whichever occurs first. Look for dirt, wear, cracks and signs of overheating.

1. Remove top capscrew securing idler support and idler bracket to rear frame (Fig. 37).
2. Loosen bottom two mounting screws enough to allow belt to pass between drive pulley and idler support (Fig. 37).
3. Raise wheel off ground enough to allow belt removal.

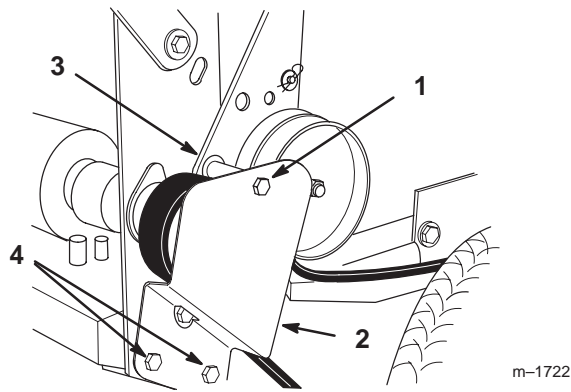

Figure 37

- | | |
|------------------|--------------------|
| 1. Top capscrew | 3. Idler support |
| 2. Idler bracket | 4. Bottom capscrew |

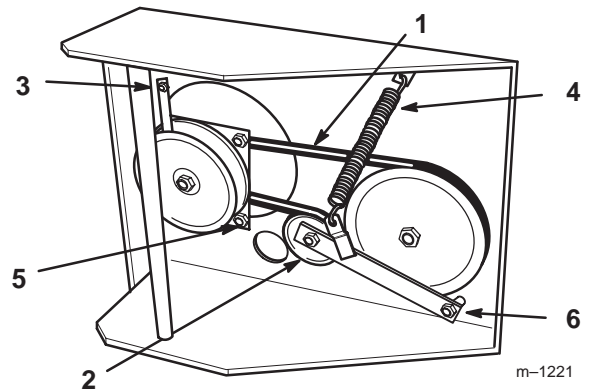

Figure 38

- | | |
|--------------------|-------------------|
| 1. Traction belt | 4. Tension spring |
| 2. Idler pulley | 5. Adjusting nut |
| 3. Clutch retainer | 6. Pivot bolt |

Replacing the Traction Belt

1. Raise the front of the machine and hold with jack stands.
2. Disconnect in-line wire connector from wire harness to electric clutch.
3. Remove mower drive belt; refer to mower Operator's Manual.
4. Remove left front engine mounting bolt securing clutch retainer to frame (Fig. 38). Unhook retainer from clutch and remove retainer.
5. Unhook tension spring from side of frame (Fig. 38).
6. Loosen pivot bolt enough to remove traction belt from the drive pulley and clutch.
7. Install new belt around clutch and drive pulley.
8. Torque pivot bolt to 35-40 ft.-lb. (47-54 N.m). Install tension spring between idler arm and frame bracket (Fig. 38).
9. Hook clutch retainer into clutch and secure to frame with engine mounting bolt. Torque engine mounting bolt to 170-220 in.-lb. (19-24 N.m).
10. Connect clutch in-line wire connector to wire harness.

Adjusting the Electric Clutch

The clutch is adjustable to ensure proper engagement and proper braking. Check adjustment after every 100 hours of operation.

1. To adjust clutch, tighten or loosen lock nuts on flange studs (Fig. 39).
2. Check adjustment by inserting feeler gauge thru slots next to studs (Fig. 39).
3. The proper disengaged clearance between the clutch plates is .012-.018 in. (0.30-0.45 mm). It will be necessary to check this clearance at each of the three slots to ensure the plates are parallel to each other.

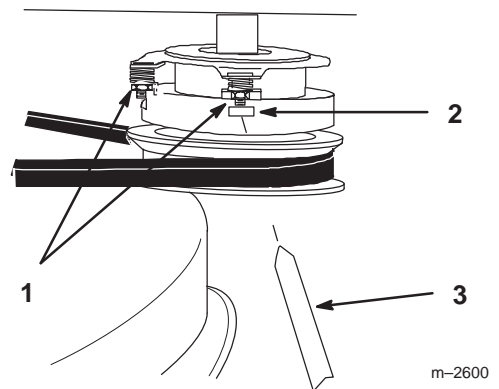
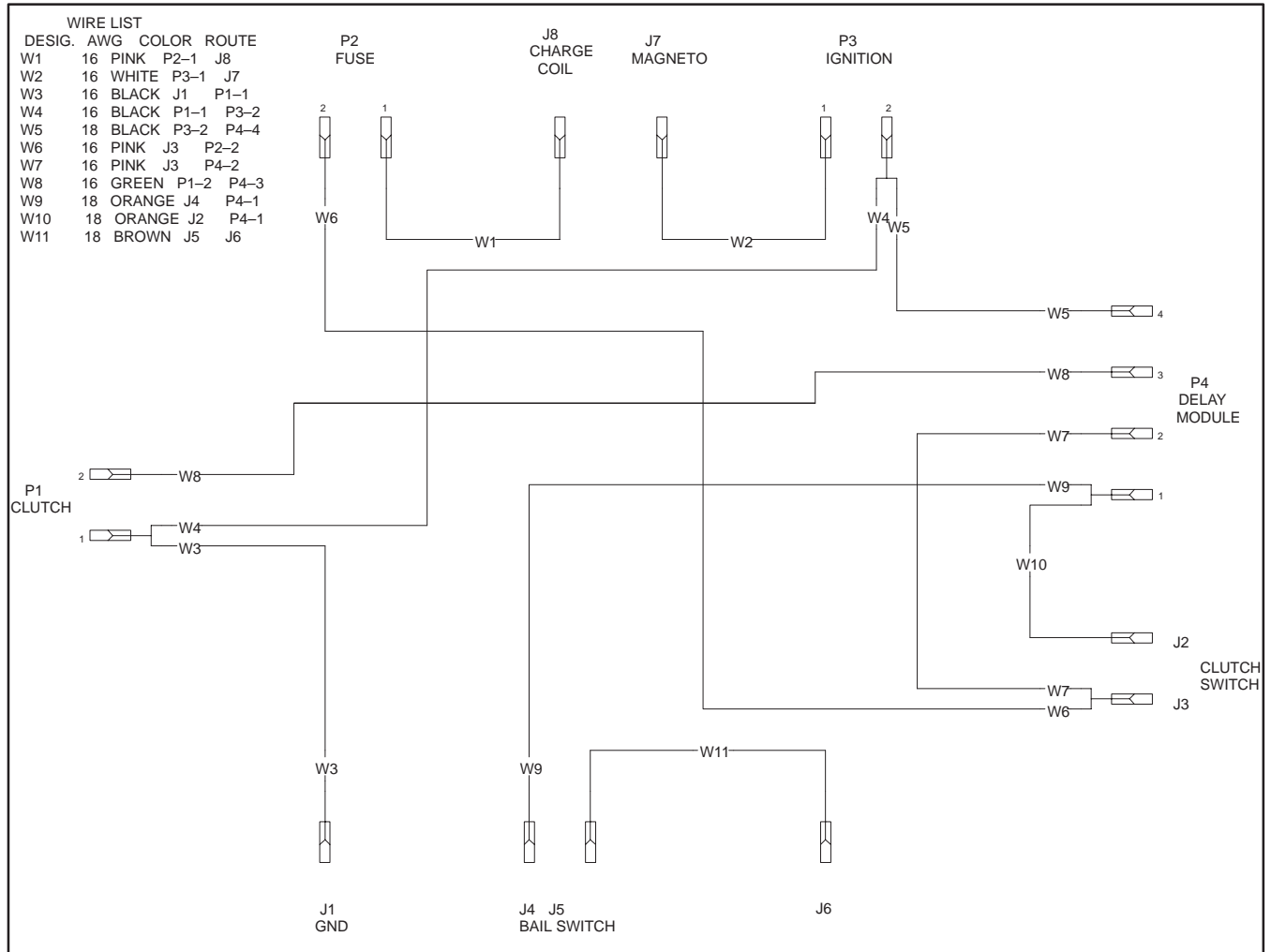

Figure 39

- | | |
|------------------|-----------------|
| 1. Adjusting nut | 3. Feeler gauge |
| 2. Slot | |

Wiring Diagram



Cleaning and Storage

1. Disengage the power take off (PTO), set the parking brake, and turn the ignition key to off. Remove the key.
 2. Remove grass clippings, dirt, and grime from the external parts of the entire machine, especially the engine. Clean dirt and chaff from the outside of the engine's cylinder head fins and blower housing.
- Important** You can wash the machine with mild detergent and water. Do not pressure wash the machine. Avoid excessive use of water, especially near the control panel, and engine.
3. Check the brake; refer to Servicing the Brake, page 26.
 4. Service the air cleaner; refer to Servicing the Air Cleaner, page 22.
 5. Grease the machine; refer to Greasing and Lubrication, page 25.

6. Change the crankcase oil; refer to Servicing the Engine Oil, page 23.
7. Check the tire pressure; refer to Checking the Tire Pressure, page 26.
8. For long-term storage (more than 90 days) add stabilizer/conditioner additive to fuel in the tank (1 oz. per gallon).
 - A. Run engine to distribute conditioned fuel through the fuel system (5 minutes).
 - B. Stop engine, allow to cool and drain the fuel tank; refer to Servicing the Fuel Tank, page 26, or operate engine until it stops.
 - C. Restart engine and run until it stops. Repeat, on choke until engine will not restart.
 - D. Dispose of fuel properly. Recycle as per local codes.

Note: Do not store stabilizer/conditioned gasoline over 90 days.

9. Remove the spark plug(s) and check its condition; refer to Servicing the Spark Plug, page 24. With the spark plug(s) removed from the engine, pour two tablespoons of engine oil into the spark plug hole. Now use the starter to crank the engine and distribute the oil inside the cylinder. Install the spark plug(s). Do not install the wire on the spark plug(s).
10. Check and tighten all bolts, nuts, and screws. Repair or replace any part that is damaged or defective.

11. Paint all scratched or bare metal surfaces. Paint is available from your Authorized Service Dealer.
12. Store the machine in a clean, dry garage or storage area. Remove the key from the ignition switch and keep it in a memorable place. Cover the machine to protect it and keep it clean.

Troubleshooting

PROBLEM	POSSIBLE CAUSES	CORRECTIVE ACTION
Engine will not start, starts hard, or fails to keep running.	<ol style="list-style-type: none"> 1. Fuel tank is empty. 2. Choke is not on. 3. Air cleaner is dirty. 4. Spark plug wire is loose or disconnected. 5. Spark plug is pitted, fouled, or gap is incorrect. 6. Dirt in fuel filter. 7. Dirt, water, or stale fuel is in fuel system. 	<ol style="list-style-type: none"> 1. Fill fuel tank with gasoline. 2. Move choke lever to the on position. 3. Clean or replace air cleaner element. 4. Install wire on spark plug. 5. Install new, correctly gapped spark plug. 6. Replace fuel filter. 7. Contact Authorized Service Dealer.
Engine loses power.	<ol style="list-style-type: none"> 1. Engine load is excessive. 2. Air cleaner is dirty. 3. Oil level in crankcase is low. 4. Cooling fins and air passages under engine blower housing are plugged. 5. Spark plug is pitted, fouled, or gap is incorrect. 6. Vent hole in fuel cap is plugged. 7. Dirt in fuel filter. 8. Dirt, water, or stale fuel is in fuel system. 	<ol style="list-style-type: none"> 1. Reduce ground speed. 2. Clean air cleaner element. 3. Add oil to crankcase. 4. Remove obstruction from cooling fins and air passages. 5. Install new, correctly gapped spark plug. 6. Clean or replace the fuel cap. 7. Replace fuel filter. 8. Contact Authorized Service Dealer.
Engine overheats.	<ol style="list-style-type: none"> 1. Engine load is excessive. 2. Oil level in crankcase is low. 3. Cooling fins and air passages under engine blower housing are plugged. 	<ol style="list-style-type: none"> 1. Reduce ground speed. 2. Add oil to crankcase. 3. Remove obstruction from cooling fins and air passages.

PROBLEM	POSSIBLE CAUSES	CORRECTIVE ACTION
Abnormal vibration.	<ol style="list-style-type: none"> 1. Engine mounting bolts are loose. 2. Loose engine pulley, idler pulley, or blade pulley. 3. Engine pulley is damaged. 	<ol style="list-style-type: none"> 1. Tighten engine mounting bolts. 2. Tighten the appropriate pulley. 3. Contact Authorized Service Dealer.
Machine does not drive.	<ol style="list-style-type: none"> 1. Shift lever is in neutral. 2. Traction belt is worn, loose or broken. 3. Traction belt is off pulley. 	<ol style="list-style-type: none"> 1. Move shift lever to a drive gear position. 2. Change Belt. 3. Change Belt.



LCE

The Toro Total Coverage Guarantee

A One-Year Limited Warranty

Conditions and Products Covered

The Toro Company and its affiliate, Toro Warranty Company, pursuant to an agreement between them, jointly promise to repair any Toro Product used for commercial, institutional, or rental purposes if defective in materials or workmanship. The following time periods apply from the date of purchase:

<u>Products</u>	<u>Warranty Period</u>
• All Products	1 year
• All Spindles	2 years parts and labor; third year, parts only
• Engines/Hydraulic Systems* on the following: Outfront and Mid-Mount Z's ProLine Mid-Size Mowers Groundsmaster® Riding Mowers Backpack Blowers	2 years
• Deck Shells (36"–72") on the following: ProLine Mid-Size Mowers Mid-Mount Z's	2 years
• Electric Clutch on 200 Series Mid-Mount Z's	2 years

This warranty includes the cost of parts and labor, but you must pay transportation costs.

This warranty applies to:

- Outfront and Mid-Mount Z's
- ProLine Mid-Size Mowers
- Groundsmaster Riding Mowers
- Turf Maintenance Equipment
- Debris Management Equipment

* Some engines used on Toro LCE Products are warranted by the engine manufacturer.

Instructions for Obtaining Warranty Service

If you think that your Toro Product contains a defect in materials or workmanship, follow this procedure:

1. Contact any Toro Authorized or Master Service Dealer to arrange service at their dealership. To locate a dealer convenient to you, access our website at www.Toro.com. U.S. Customers may also call 800-348-2424.
2. Bring the product and your proof of purchase (sales receipt) to the Service Dealer.

If for any reason you are dissatisfied with the Service Dealer's analysis or with the assistance provided, contact us at:

LCB Customer Service Department
Toro Warranty Company
8111 Lyndale Avenue South
Bloomington, MN 55420-1196
888-577-7466 (U.S. customers)
877-484-9255 (Canada customers)

Countries Other than the United States or Canada

Customers who have purchased Toro products exported from the United States or Canada should contact their Toro Distributor (Dealer) to obtain guarantee policies for your country, province, or state. If for any reason you are dissatisfied with your Distributor's service or have difficulty obtaining guarantee information, contact the Toro importer. If all other remedies fail, you may contact us at Toro Warranty Company.

Owner Responsibilities

You must maintain your Toro Product by following the maintenance procedures described in the operator's manual. Such routine maintenance, whether performed by a dealer or by you, is at your expense.

Items and Conditions Not Covered

There is no other express warranty except for special emission system coverage on some products. This express warranty does not cover the following:

- Cost of regular maintenance service or parts, such as filters, fuel, lubricants, tune-up parts, blade sharpening, brake and clutch adjustments.
- Any product or part which has been altered or misused or required replacement or repair due to normal wear, accidents, or lack of proper maintenance.
- Repairs necessary due to improper fuel, contaminants in the fuel system, or failure to properly prepare the fuel system prior to any period of non-use over three months.
- Pickup and delivery charges.

All repairs covered by this warranty must be performed by an Authorized Toro Service Dealer using Toro approved replacement parts.

General Conditions

Repair by an Authorized Toro Service Dealer is your sole remedy under this warranty.

Neither The Toro Company nor Toro Warranty Company is liable for indirect, incidental or consequential damages in connection with the use of the Toro Products covered by this warranty, including any cost or expense of providing substitute equipment or service during reasonable periods of malfunction or non-use pending completion of repairs under this warranty.

Some states do not allow exclusions of incidental or consequential damages, or limitations on how long an implied warranty lasts, so the above exclusions and limitations may not apply to you.

All implied warranties of merchantability (that the product is fit for ordinary use) and fitness for use (that the product is fit for a particular purpose) are limited to the duration of the express warranty.

This warranty gives you specific legal rights, and you may also have other rights which vary from state to state.