



Count on it.

Operator's Manual

**Reelmaster® 5, 7, and 11-Blade
Reel Mower**

Model No. 01005—Serial No. 403460001 and Up

Model No. 01007—Serial No. 403460001 and Up

Model No. 01011—Serial No. 403460001 and Up



Safety

This machine has been designed in accordance with EN ISO 5395 and ANSI B71.4–2017.

General Safety

This product is capable of amputating hands and feet. Always follow all safety instructions to avoid serious personal injury.

- Read and understand the contents of this *Operator's Manual* before starting the machine.
- Use your full attention while operating the machine. Do not engage in any activity that causes distractions; otherwise, injury or property damage may occur.
- Do not put your hands or feet near moving components of the machine.
- Do not operate the machine without all guards and other safety protective devices in place and functioning properly on the machine.
- Keep clear of any discharge opening.
- Keep bystanders and children out of the operating area. Never allow children to operate the machine.
- Before you leave the operator's position, do the following:
 - Park the machine on a level surface.
 - Lower the cutting unit(s).
 - Disengage the drives.
 - Engage the parking brake (if equipped).
 - Shut off the engine and remove the key (if equipped).
 - Wait for all movement to stop.

Improperly using or maintaining this machine can result in injury. To reduce the potential for injury, comply with these safety instructions and always pay attention to the safety-alert symbol▲, which means Caution, Warning, or Danger—personal safety instruction. Failure to comply with these instructions may result in personal injury or death.

Cutting Unit Safety

- The cutting unit is only a complete machine when installed on a traction unit. Read the traction unit *Operator's Manual* carefully for complete instructions on the safe use of the machine.
- Stop the machine, remove the key (if equipped), and wait for all movement to stop before inspecting the attachment after striking an object or if there is an abnormal vibration in the machine. Make all necessary repairs before resuming operation.

Cutting Unit Safety.....	3
Blade Safety.....	4
Safety and Instructional Decals.....	4
Setup.....	5
Removing the Cutting Unit from the Carton.....	5
Installing the Wheels.....	5
Product Overview.....	5
Specifications.....	5
Operation.....	6
Adjusting the Bedknife to the Reel for Light Contact.....	6
Adjusting the Bedknife to the Reel.....	6
Adjusting the Height of Cut.....	7
Operating Tips.....	8
Causes of Poor Quality of Cut.....	8
Maintenance.....	10
Lubrication.....	10
Checking the Gear Case Oil.....	10
Changing the Gear Case Lubricant.....	10
Checking the Wheel Hubs.....	10
Checking the Fasteners and Reel Bearings.....	11
Adjusting the Reel Bearings.....	11
Grinding the Cutting Unit.....	11
Lapping the Cutting Unit.....	12
Replacing the Bedknife.....	13
Adjusting the Reel, Roller, and Wheel Bearing.....	14
Servicing the Roller.....	14

- Keep all parts in good working condition and all hardware tightened. Replace all worn or damaged decals.
- Use only accessories, attachments, and replacement parts approved by Toro.

- Inspect the blade periodically for wear or damage.
- Use care when checking the blades. Wrap the blades or wear gloves, and use caution when servicing the blades. Only replace or sharpen the blades; never straighten or weld them.
- On multi-bladed machines, take care as rotating 1 blade can cause other blades to rotate.

Blade Safety

A worn or damaged blade can break, and a piece of the blade could be thrown toward you or bystanders, resulting in serious personal injury or death.

Safety and Instructional Decals



Safety decals and instructions are easily visible to the operator and are located near any area of potential danger. Replace any decal that is damaged or missing.

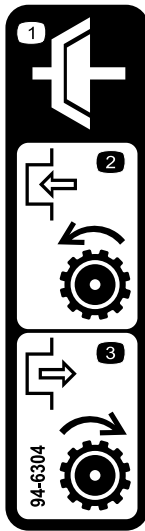

94-6304

decal94-6304

1. Clutch
2. Turn counterclockwise to engage.
3. Turn clockwise to disengage.

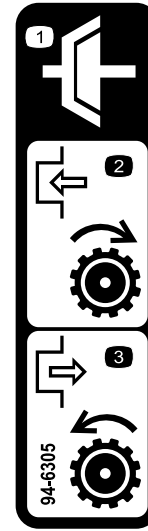

94-6305

decal94-6305

1. Clutch
2. Turn clockwise to engage.
3. Turn counterclockwise to disengage.

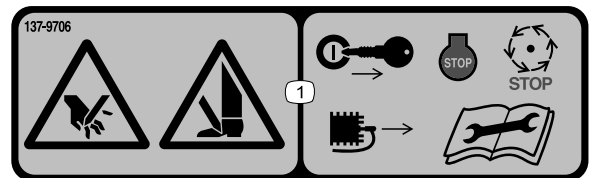

137-9706

decal137-9706

1. Cutting hazard of the hand or foot—shut off the engine, remove the key or disconnect the spark plug, wait for all moving parts to stop, and read the *Operator's Manual* before performing maintenance.

Setup

Media and Additional Parts

Description	Qty.	Use
Operator's Manual Parts Catalog (not included)—refer to the included postcard for information on obtaining the Parts Catalog	1 —	Review the material and save it in an appropriate place.

Note: Determine the left and right sides of the machine from the normal operating position.

Removing the Cutting Unit from the Carton

1. Slit the four corners of the carton so that the sides lie flat.
2. Remove the shipping caps from the wheel hubs.

Note: Keep the shipping caps. Install them on the wheel hubs to prevent grinding dust from entering wheel bearing whenever you grind the reel.

Installing the Wheels

1. Remove the shipping caps from the wheel hubs.
2. Install the drive wheels with cap screws and lock washers (Figure 3).

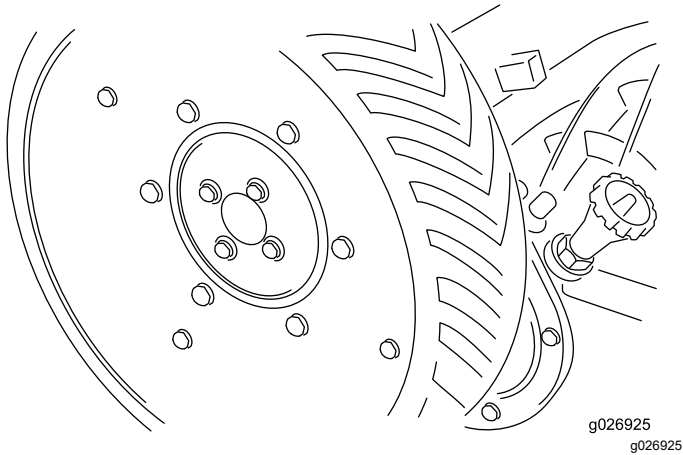

Figure 3

Product Overview

Specifications

Weight 11 Blade 7 Blade 5 Blade (All with 0.406 m (16 inch) semi-pneumatic tires, without draw bars)	114 kg (252 lb) 112 kg (248 lb) 110 kg (243 lb)
Width	1.054 m (41-1/2 inches) with iron wheels, 1.143 m (45 inches) with semi-pneumatic tires
Height	0.406 m (16 inches) or 0.457 m (18 inches) depending on tires

Operation

Note: Determine the left and right sides of the machine from the normal operating position.

Adjusting the Bedknife to the Reel for Light Contact

Important: After the cutting unit is set up and installed on the towing frame, the bedknife and reel must be adjusted for light contact. Adjust the bedknife to the reel while the cutting unit is sitting on the grass to be cut because the force of turf against underside of bedknife during actual operation must be duplicated to ensure the correct setting. To ensure sharp cutting edges, the bedknife and reel must have light contact.

1. Stand behind the cutting unit.
2. Disengage the reel throwout knobs (Figure 4). Carefully spin the reel backward to ensure free movement.
3. While spinning the reel backward, rotate the bedknife adjusting knob counterclockwise (Figure 4) until the bedknife does not touch the reel blades.

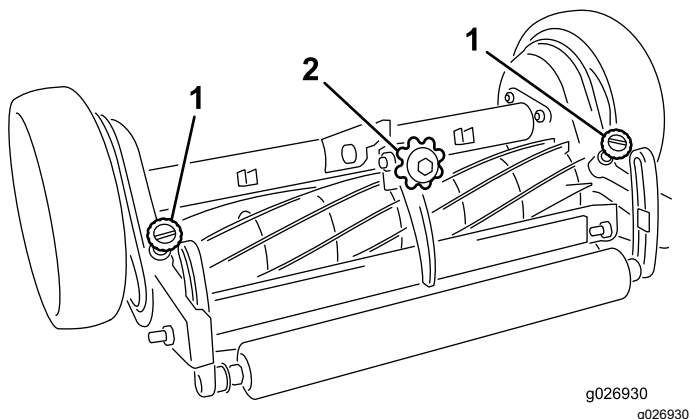

Figure 4

1. Throwout knobs
2. Bedknife adjusting knob

4. While spinning the reel backward, rotate the adjusting knob clockwise (Figure 4), one click at a time, until light contact of the bedknife and the reel is noticed or a whispering cutting sound is heard.

Note: The spring arm (clicker) may be adjusted for positive detent by loosening the capscrews securing the spring arm to the adjustment arm retainer, adjust until a solid clicking sound is achieved when the adjusting knob is turned, and retighten the capscrews.

5. Check the reel “carry over” by spinning the reel backward again. The reel should rotate one

to two complete revolutions. Less than one revolution indicates heavy contact, which means the bedknife and reel must be readjusted for light contact; refer to steps 1, 3, and 4.

6. At the beginning of the cutting day, when the reels are cold, engage the reel throwout knobs (Figure 4). Operate the cutting units for 15 to 20 minutes so that the bedknife and reel reach normal operating temperature; then stop the operation. Next, disengage the reel throwout knobs and spin the reel backward. A whispering sound, not clicking, should be emitted, and this assures the correct adjustment. If a whispering sound is not heard, the bedknife and reel must be readjusted; refer to steps 3–5. By contrast, when the reels are warm from being used, use only steps 1–5 to maintain light contact between the bedknife and the reel.

Important: Never adjust the bedknife to the reel for light contact if the cutting units are cold because the increase in temperature during operation could cause the metal to expand and result in heavy contact. Heavy contact causes uneven bedknife wear and poor quality of cut. However, light contact between the bedknife and the reel, which is desirable, minimizes the wear and keeps the cutting edges sharp. Adjust for light contact every four hours or sooner, even though quality of cut is acceptable. When cutting units are operated in sparse grass or the temperature of the air is high, the adjustment for light contact must be checked even more frequently to avoid heavy contact between the bedknife and reel. If cutting units are not operated for a short time, one hour after any use, check for light contact after resuming operation for 15 to 20 minutes; refer to steps 1–6.

Adjusting the Bedknife to the Reel

1. Position the cutting unit on a level surface. Remove any paint and grease from the bedknife and the reel cutting edges.
2. Make sure that the throwout knobs (Figure 5) are disengaged and the bedknife to reel contact is removed by turning the bedknife adjustment knob counterclockwise.
3. Insert a long strip of newspaper between the reel blade and the bedknife. While rotating the reel backward, turn the bedknife adjusting knob (Figure 5) clockwise, one click at a time, until the paper is pinched lightly, which results in the

paper being cut or a slight drag when the paper is pulled.

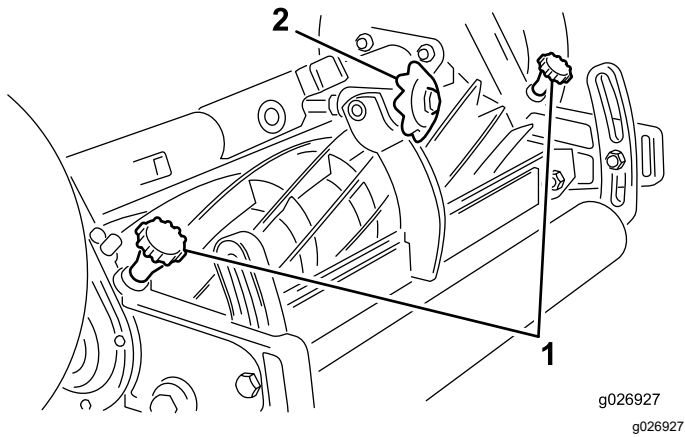

Figure 5

1. Throwout knobs
2. Bedknife adjusting knob

4. Continue to check for light contact across the full length of bedknife using paper. If light contact is not evident, the bedknife is not parallel to the reel.
5. Loosen the nut on the left bedbar pivot bolt enough to ease turning of eccentric bolt.
6. Parallel the bedknife to the reel by rotating the left bed-bar pivot bolt (Figure 6). The left pivot bolt has an offset thread which, when rotated, acts as a cam to raise or lower the bedbar. On the left hand pivot bolt there is an offset dot (Figure 6) which denotes the thread of the bolt. When the dot is in the up position (Figure 6) the left end of bedbar is raised. As the bolt is turned clockwise and the dot is lowered, so is the left end of the bedbar. The identification dot is to be positioned within the rear (180 degree) position when adjusting.

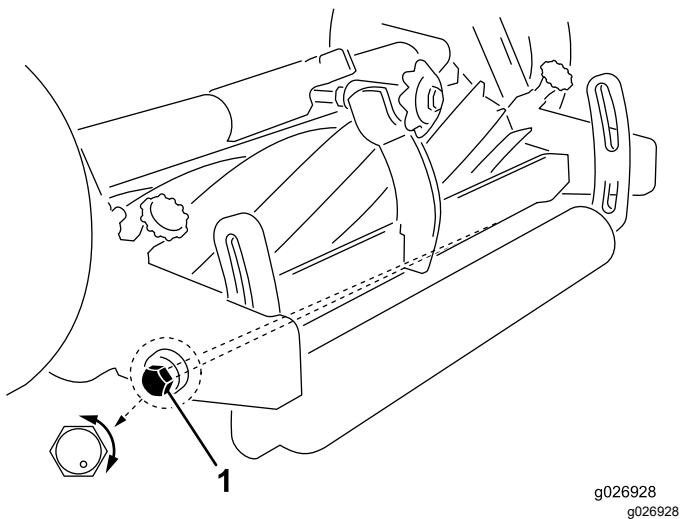

Figure 6

1. Bedbar pivot bolt

7. Rotate the left pivot bolt to raise or lower the bedbar.
8. Insert a long strip of newspaper between the reel blade and the bedknife. While rotating the reel backward, turn the bedknife adjusting knob clockwise, one click at a time, until the paper is pinched lightly, which results in the paper being cut or a slight drag when the paper is pulled.
9. When light contact is evident across the full length of bedknife, tighten the pivot bolt nut, while holding the bolt in position and check to make sure that the pivot bolt did not become misadjusted when tightened. Readjust as required.

Important: To make sure that the bedknife and the reel are not damaged while the cutting units are transported to or installed on the towing frame, rotate the bedknife adjusting knob counterclockwise until the bedknife does not touch the reel.

Adjusting the Height of Cut

The height of cut is adjustable in approximately 2.38 mm (3/32 inch) increments by raising or lowering rear roller.

1. Loosen the capscrews securing the adjusting nuts in the roller brackets (Figure 7).

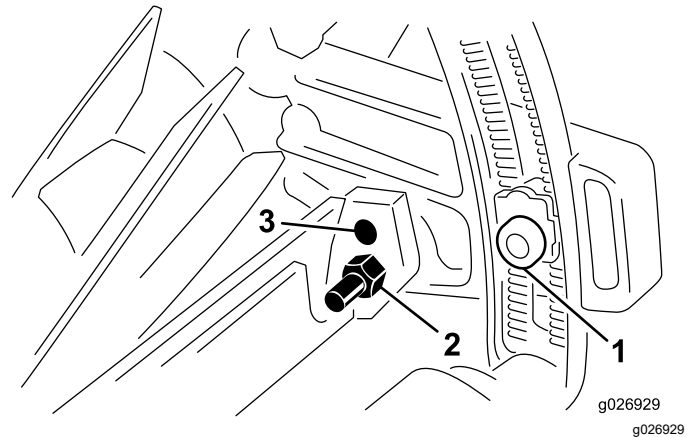

Figure 7

1. Bottom edge of adjusting nut
2. 11 blade mounting hole
3. 5 and 7 blade mounting hole

2. Position the roller adjusting nuts in the desired notches and tighten the capscrews. Make sure that the same number of notches show below the adjusting nuts.
3. If a higher height of cut is desired, every notch moved adds approximately 2.38 mm (3/32 inch) to the cutting height.

Note: These are bench settings. The cutting unit will cut at a different height in turf because of grass conditions and the weight of the cutting unit.

4. To make a finer adjustment to the cutting height or to adjust the roller, the adjusting nut may be moved 1/2 notch or 1.19 mm (3/64 inch) by using the following procedure:
 - A. Remove the capscrew and the adjusting nut securing the roller bracket to the gear case. Do not move the roller bracket.
 - B. Reposition the capscrew and the adjusting nut to the upper hole in the gear case.
 - C. Slide the roller bracket up or down 1/2 notch to position the adjusting nut into the correct notch and tighten the capscrew.

Operating Tips

- **Mowing Speed**—The cutting unit is designed to cut grass well at any ground speed between 1.6 and 9.66 km/h (1 and 6 mph) but for most turf conditions, ground speeds of 6.4 to 9.66 km/h (4 to 6 mph) produce the best quality of cut. Ground speed, however, must be reduced when turning because excessive speed will cause the outside cutting units to bounce and skip on the turf. Excessive heat, caused by the reel spinning too fast, can also damage the bedknife and the reel. Since the grass lubricates the bedknife and reel during operation, slow down when cutting sparse grass, extremely dry grass, or when trimming. Any lack or significant reduction of lubrication produces excessive heat buildup and, subsequently, heavy contact between the bedknife and the reel, which results in uneven bedknife wear and poor quality of cut. Therefore, reels must be disengaged and stopped before mowers are transported across parking lots, roads, or whenever the lubrication is minimal.
- **Height of Cut**—To determine the effective height of cut, the length of the grass to be cut must be checked. The height of cut should be set and the turf mowed frequently so that no more than 1/3 of the leaf is cut off. If the cutting unit is equipped with pneumatic tires, pressure must be maintained at 241.3 kpa (35 psi). Low tire pressure can cause bedknife to dip into the grass and scalp the turf. An uneven cut will likely result.
- **Operating Sound** —A cutting unit that is adjusted correctly gives off a whispering sound when operated. If there are buzzing, clicking, or metallic sounds, the cutting unit has probably been operated with heavy contact between the bedknife and the reel. The reel or bedknife could also have hit a foreign object. A noisy cutting unit must be

stopped, repaired, and adjusted or severe damage will result.

- **Mowing Pattern**—To prevent grass from lying down and improved appearance of the turf, alternate mowing directions if possible, each time an area is cut.

Causes of Poor Quality of Cut

1. **Bedknife/Reel Contact** (Figure 8) – There must be light contact between the bedknife and the reel to keep the cutting edges sharp and to produce an excellent quality of cut. By contrast, cutting units operated without light contact allow abrasive materials and grass to pass between the bedknife and the reel. This eroding action rounds off the bedknife and the reel cutting edges, which results in a poor quality of cut. If the cutting edges become round, the bedknife and the reel must be lapped. Excessive rounding off of the cutting edges may require that the bedknife and the reel be ground and lapped. Never compensate for round cutting edges by tightening the bedknife adjusting knob until there is heavy contact because the bedknife and the reel will wear unevenly and cause a rifling effect.

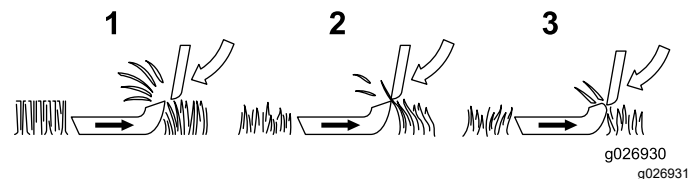

Figure 8

1. Sharp edges, light contact
2. No contact, edges get dulled
3. Contact adjustment, dull edges

Note: Rifling is the uneven or wavy condition that develops on the bedknife and the reel when there is heavy contact between these two parts (Figure 9). Streaks of uncut grass and an overall poor quality of cut are signs of rifling. Grinding the bedknife and reel is the only way to repair a rifled cutting unit.

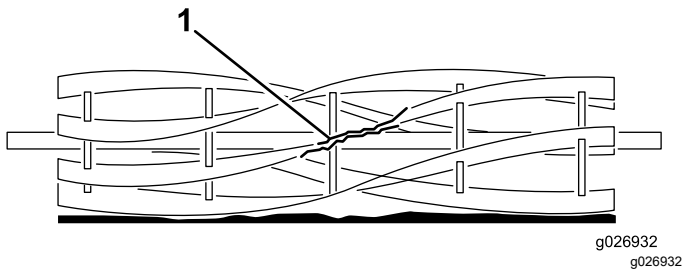

Figure 9

1. Nicked reel blades

2. **Noise** – A cutting unit that has sharp cutting edges and is adjusted with light contact will emit a desirable whispering sound when the reel is spinning. By contrast, buzzing, clicking, or metallic sounds during operation indicate that the cutting unit is probably being operated with heavy contact between the bedknife and the reel. Heavy contact causes uneven or wavy wear on the bedknife and reel cutting edges. Grinding is required to repair a damaged bedknife and reel. Although the bedknife and reel are adjusted correctly for light contact, notches will eventually develop at both ends of the bedknife. These notches must be rounded off or filed flush with cutting edge of bedknife to assure smooth operation.
3. **Loose Reel Bearings** – If reel bearings are suspected to be loose, check them immediately or extensive damage may result; refer to Reel Bearing Adjustment.
4. **Hitting a Foreign Object** – The bedknife and the reel cutting edges can be damaged if a foreign object is hit. The damage, if it is not too severe, can be repaired in the field. Start by filing down high spots on the bedknife and the reel (Figure 10). Use a ball peen hammer to straighten any reel blades that may be bent. Since the bedknife usually springs away from the reel upon impact, the bedknife must be adjusted; refer to Parallel the Bedknife to the Reel.

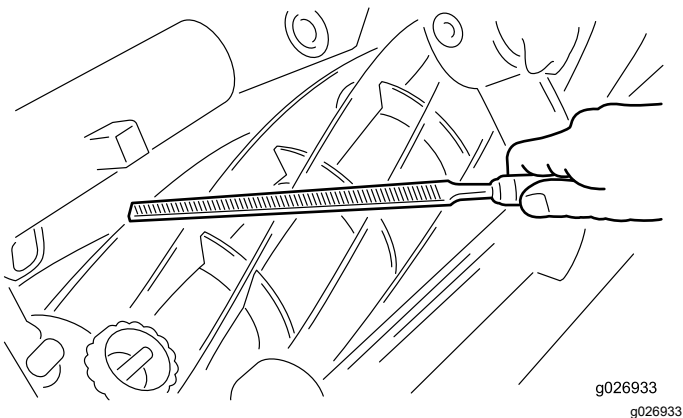

Figure 10

Maintenance

Lubrication

Greasing the Cutting Unit

Each cutting unit has 4 grease fittings (Figure 11) that must be lubricated every 8 hours of operation with heavy duty No. 2 wheel bearing grease.

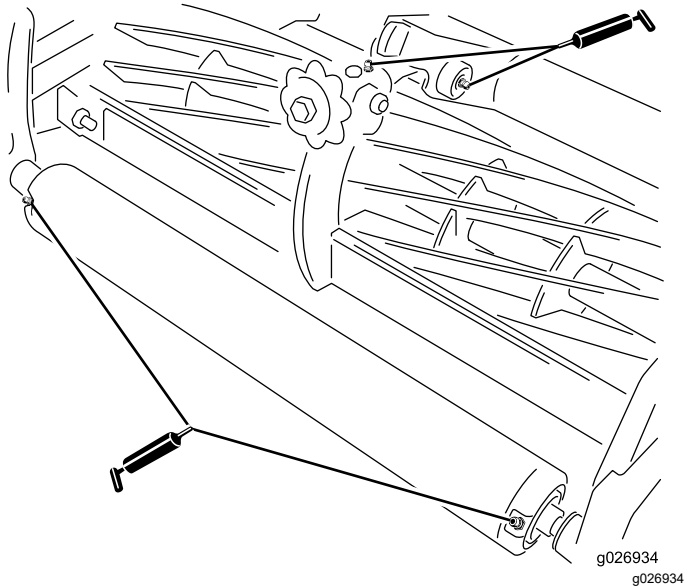

Figure 11

Note: Do not use high pressure hose to clean areas where there are seals or bearings because foreign matter will likely be forced into the bearing. The result will be rapid seal and bearing deterioration. Lubricating the cutting unit immediately after washing helps purge water out of bearings and increases bearing life.

1. Wipe each grease fitting with a clean rag.
2. Apply the grease. When you feel pressure while greasing the roller, the bearing cavity between the seals is full.

Important: Do not continue to grease because the inner bearing seal may get damaged.

3. Wipe away any excess grease.

Checking the Gear Case Oil

1. Position the cutting unit on a level surface.
2. Raise and block the back of the cutting unit until there is approximately 26 cm (10-1/4 inches) between the bottom of the gear case extending behind the roller bracket and the level surface (Figure 12).

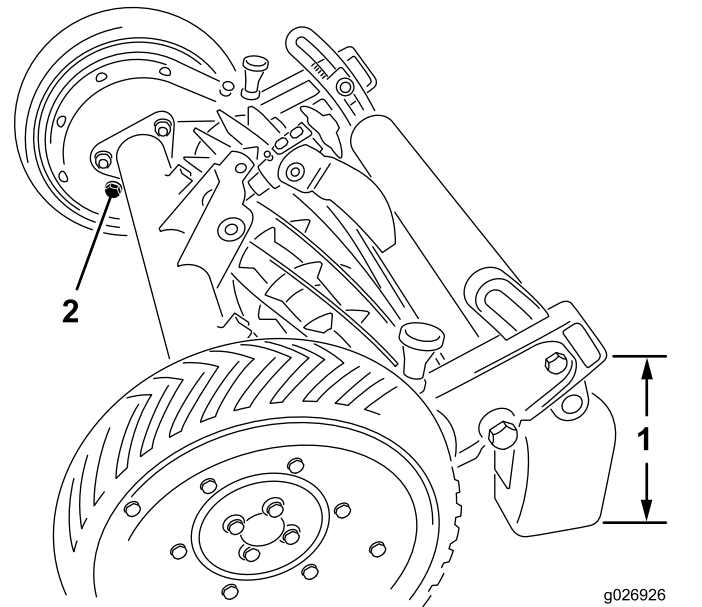

Figure 12

1. 26 cm (10-1/4 inches)
2. Filler plug

3. Remove the filler plug from inside of each gear case (Figure 12). Check the oil level in the gear case; it should be level with the bottom of the filler hole. If the oil is level with bottom of the hole, install the filler plug.

Important: Check for oil leaks caused by a worn or improperly installed O-ring or gasket, and loose side-plate bolts. Make all repairs before adding oil to the gear cases.

4. If the oil level is low, fill the gear case with 80W-90 gear lubricant to the point of overflowing and then install the filler plug.

Important: Do not overfill the gear case.

Changing the Gear Case Lubricant

Service Interval: Yearly

The gear cases have been fully lubricated at the factory. Once each season, drain and clean the right and left gear cases. When the gear cases are clean, add 80W-90 gear lubricant; refer to [Checking the Gear Case Oil](#) (page 10).

Checking the Wheel Hubs

1. Remove the wheels.
2. Rotate the wheel hub (Figure 13) to check the bearing adjustment. You should feel a slight drag when you rotate the hub. If drag is not evident, tighten the wheel hub nut (Figure 13) until you feel a slight drag when you rotate the hub.

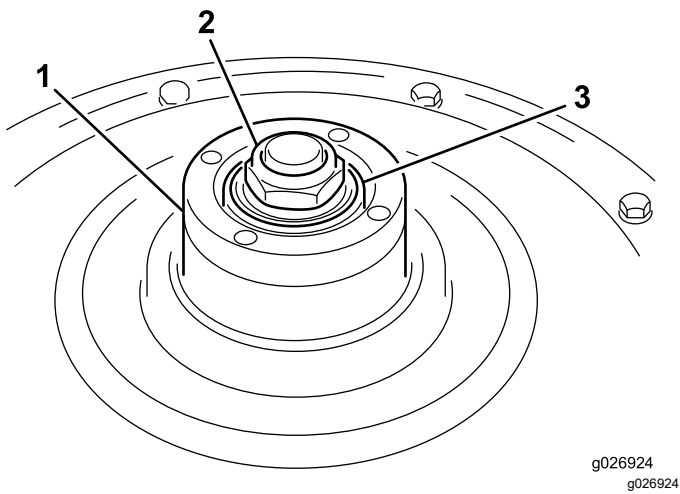

Figure 13

1. Wheel hub
2. Wheel hub nut
3. O-ring

Important: Do not over-tighten the wheel hub nut because the bearing will wear rapidly.

3. Check the O-ring to assure it is not damaged, and make sure that it is seated in the inside diameter of the wheel hub (Figure 13).

Important: An O-ring that is damaged or installed incorrectly will allow oil to leak out of the gear case. If enough oil leaks out, mechanical damage will likely result.

4. If pneumatic wheels are installed, set the tire pressure at 241.3 Kpa (35 psi).
5. Install the drive wheels with cap screws and lock washers (Figure 14).

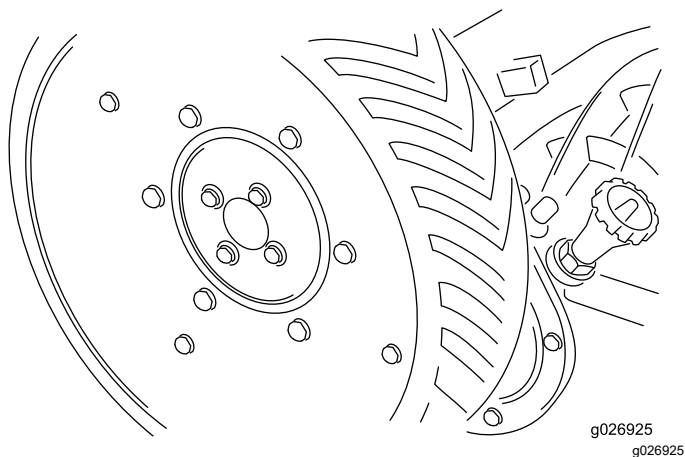

Figure 14

Checking the Fasteners and Reel Bearings

1. Rotate the center adjusting knob until the bedknife does not contact the reel. Try to spin the reel. If the reel does not spin, adjust the reel bearings; refer to Adjusting the Reel Bearing in the Maintenance Section. If the reel spins freely, proceed to the next step.
2. Try to move the reel back and forth. If the reel can be moved, adjust the reel bearings; refer to [Adjusting the Reel Bearings \(page 11\)](#).
3. Check and tighten all nuts, bolts, and screws to ensure that all parts are secure.

Adjusting the Reel Bearings

If end play is evident in the reel or if the cutting unit has been disassembled, an adjustment to the reel bearing may be necessary.

1. Remove the 4 screws securing the left wheel to the wheel hub and remove the wheel. Place the wheel under the gear case for support.
 2. Raise and block the back of the cutting unit until there is 0.178 to 0.203 m (7 to 8 inches) between the bottom of the gear case extending behind the roller bracket and the level surface.
 3. Remove the 3 cap screws securing the inspection cover to the gear case cover.
 4. In small increments, rotate the adjusting nut on the reel shaft, in the clockwise direction to remove all end play from the reel.
- Note:** Stop the reel from rotating.
5. When the end play is removed, rotate the nut an additional 1/4 turn to preload the bearing.
 6. Install the inspection cover and the wheel.

Grinding the Cutting Unit

Note: For detailed sharpening information, refer to the *Toro Manual for Sharpening Reel and Rotary Mowers*, Form No. 09168SL.

New and old bedknives should be ground attached to the bedbar; this ensures rigidity during grinding and ensures a true knife. Refer to [Figure 15](#) when grinding the knives and obtain as near as possible the relief angles indicated. In grinding, avoid hard contact between the knife and the grinding wheel. Hard contact causes excessive heat buildup, resulting in premature wearing of the grinding wheel and reduced life of the knife.

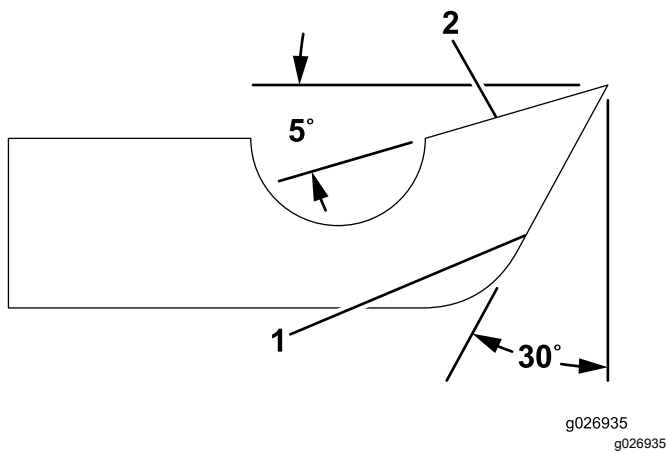

Figure 15

1. Front face
2. Cutting face

The land area and relief angle of the reel blade are pointed out in [Figure 16](#). The land area is the part of the reel blade that actually comes in contact with the bedknife and cuts the grass in a scissors action. The relief or back grind angle is ground into the reel blade to provide clearance or relief behind the contacting edges to reduce drag or friction. The recommended relief angle is 15 degrees.

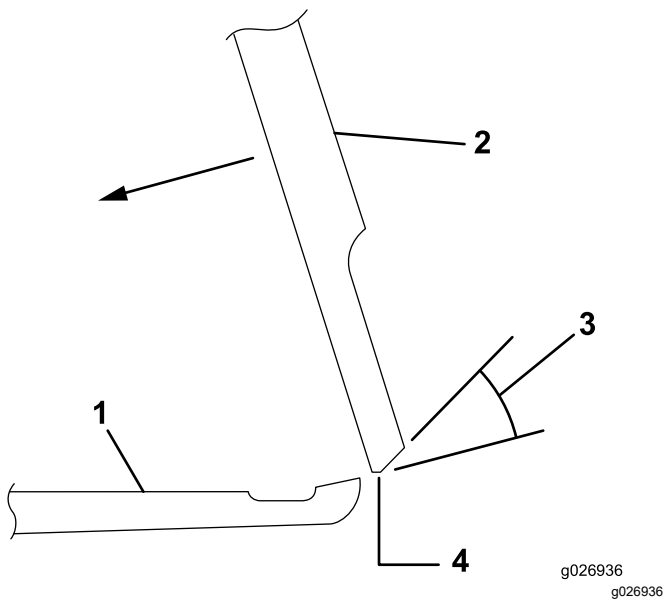

Figure 16

1. Bed knife
2. Reel blade
3. 15 to 20 degree relief angle
4. Land area established by lapping

Note: After a reel has run for an extended period of time the blade contact point or land area will keep getting wider and eventually will be the full blade width. This is normal and does not mean that the reel has to be reground to stay effective. A cutting unit can cut effectively with full width blades if the adjustment is checked frequently to maintain sharp cutting edges.

After the reel and bedknife have been ground, perform the following adjustments:

1. Set the height of cut.
2. Adjust the bedknife to the reel.

Note: As the reel blades continue to run against the bedknife a slight burr will appear on the front cutting edge surface the full length of the bedknife. If a file is occasionally run across the front edge to remove this burr, improved cutting can be obtained.

If the reel blade edges and the bedknife edge are slightly rounded and do not have severe nicks, lapping only with a lapping compound may restore the edges and match. Oftentimes a cutting unit is deemed by users to need grinding when the reel bearing adjustment, bedknife adjustment and/or lapping is all that is necessary.

Lapping the Cutting Unit

Prepare the cutting unit for lapping as follows:

1. Remove the right wheel.
2. Place the wheel under the gear case for support.
3. Remove the reel pinion cover ([Figure 17](#)).

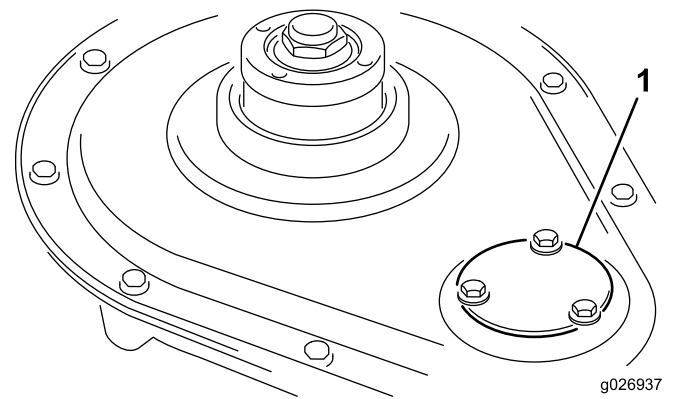

Figure 17

1. Reel pinion cover
4. Disengage the reel.
5. Connect the lapping machine coupler to the nut on the end of the reel shaft.

When lapping, use a good grade of commercial lapping compound. A medium grit should be for initial lapping and a fine grit for finishing. A solution of 1 part liquid detergent and 2 parts lapping compound is recommended. The liquid detergent greatly eases washing away the compound when finished. Water soluble oil may also be used as a compound carrier.

Note: The lapping solution must be kept in free flowing condition to get even distribution on the bedknife and reel.

The lapping procedure is as follows:

1. Adjust the bedknife to the reel so that light contact is evident.
2. Operate the lapping machine so that the reel turns in a reverse direction. Apply lapping solution continuously and maintain light bedknife-to-reel contact.
3. Stop the lapping machine periodically to check the cutting surfaces for sharpness. Continue lapping until the sharp cutting edges have been restored.

Note: If the cutting edges are severely rounded, both sharpening and lapping may be required.

4. Wash off all the lapping solution. Using paper, check for sharpness along the entire length of each reel blade. If the paper cannot be cut cleanly along the entire length of each reel blade, continued lapping is necessary.

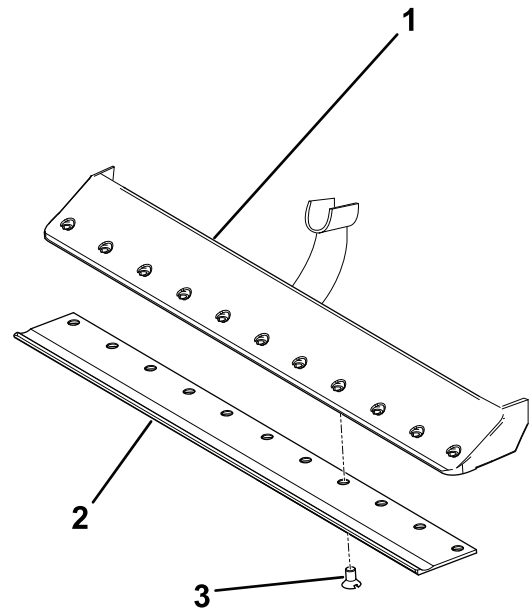

Figure 18

g282051

1. Bedbar
2. Bedknife
3. Screw

Replacing the Bedknife

1. To replace the bedknife, remove the 11 screws holding the knife to the bed bar.
2. Remove the rust, scale, and corrosion from the bedbar surface and apply a thin layer of oil to the bedbar surface.
3. Clean the screw threads.
4. Apply anti-seize compound to the screws and install the bedknife to the bedbar as follows (Figure 18):

- A. Torque the 2 outer screws to 1 N·m (10 in-lb); refer to Figure 19.
- B. Working from the center of the bedknife, torque the screws to 23 to 28 N·m (200 to 250 in-lb); refer to Figure 19.

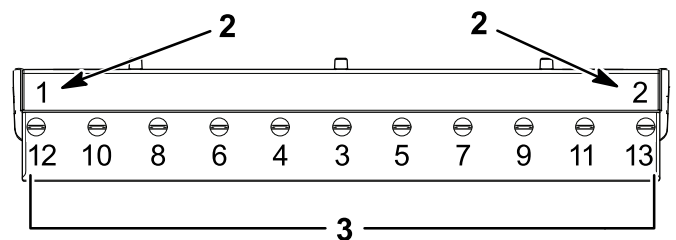
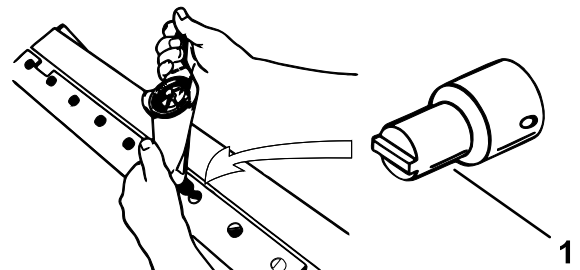

Figure 19

g282050

1. Bedknife screw tool
2. Install and torque these first to 1 N·m (10 in-lb).
3. Torque to 23 to 28 N·m (200 to 250 in-lb).

5. True the bedknife attached to the bedbar by grinding. Refer to the Toro Manual for Sharpening Reel and Rotary Mowers, Form No. 09168SL

6. After the bedknife has been ground and is true, adjust the reel, roller, and wheel bearing; refer to [Adjusting the Reel, Roller, and Wheel Bearing \(page 14\)](#).

Adjusting the Reel, Roller, and Wheel Bearing

After the initial 30 operating hours, check the reel bearing, roller bearing, and wheel bearing. Thereafter, check these parts every 200 to 250 operating hours. If necessary, adjust the reel bearing. If necessary, adjust the roller bearing. If necessary, adjust the wheel bearing.

Servicing the Roller

Disassembling the Roller

1. Remove the brackets and washers from each end of the roller and inspect the bushings.
2. Remove elastic stop nut.
Note: After the elastic stop nut has been removed, slide the sleeve off the roller shaft. Point the end of roller downward into a container, at the same time pulling the roller shaft out, allowing lubricant to drain from the roller.
3. If the roller shaft is to be replaced, remove the double jam nuts.
4. Remove the remaining sleeve and seals from both ends of the roller.
5. Remove the bearing cones from each end of the roller.
6. Remove the bearing cups with caution.
7. Remove the inner seals by using a seal remover.

Assembling the Roller

1. Lightly oil the lips of the inner seals. Install the inner seals on each end of the roller, making sure that the garter springs face inboard.
2. Replace the bearing cups and insert the bearing cones into the roller.
3. Lightly oil the lips of the outer seals. Install the outer seals on each end of the roller, making sure that the garter springs face inboard.
4. Slide 1 sleeve onto the roller shaft against the double jam nuts.
5. Wrap the threaded area of the roller shaft with cellophane tape to protect the seals, and

carefully slide the shaft through the right side of the roller. Slide the roller shaft into the roller until it penetrates the inner most oil seal on the right side.

6. Pour approximately 0.5 L (16 fl oz) of SAE 90 or 140 gear oil into the roller housing.
7. After the oil has been added, carefully push the roller shaft through the entire roller assembly. Remove the cellophane tape.
8. Install the sleeve onto the roller shaft and slide up against the bearing cone.
9. Install the elastic stop nut and secure it by holding the double jam nuts. Tighten the elastic stop nut.
Note: Tighten the elastic stop nut until all axial and radial motion has been removed from the roller shaft and bearings. Ensure that the roller rotates freely on the shaft.
10. Grease the bearings with heavy duty No. 2 wheel bearing grease.
11. Install the washers and install the left and right bracket and the bushing assemblies.

Important: After the cutting unit has been completely assembled, perform the following critical adjustments:

- A. Check the reel bearings and the fasteners.
- B. Set the height of cut.
- C. Adjust the bedknife to the reel.

Notes:

Notes:

Declaration of Incorporation

The Toro Company, 8111 Lyndale Ave. South, Bloomington, MN, USA declares that the following unit(s) conform(s) to the directives listed, when installed in accordance with the accompanying instructions onto certain Toro models as indicated on the relevant Declarations of Conformity.

Model No.	Serial No.	Product Description	Invoice Description	General Description	Directive
01005	403460001 and Up	Reelmaster 5-Blade Reel Mower	REELMASTER 5	Reelmaster 5-Blade Reel Mower	2006/42/EC
01007	403460001 and Up	Reelmaster 7-Blade Reel Mower	REELMASTER 7	Reelmaster 7-Blade Reel Mower	2006/42/EC
01011	403460001 and Up	Reelmaster 11-Blade Reel Mower	REELMASTER 11	Reelmaster 11-Blade Reel Mower	2006/42/EC

Relevant technical documentation has been compiled as required per Part B of Annex VII of 2006/42/EC.

We will undertake to transmit, in response to requests by national authorities, relevant information on this partly completed machinery. The method of transmission shall be electronic transmittal.

This machinery shall not be put into service until incorporated into approved Toro models as indicated on the associated Declaration of Conformity and in accordance with all instructions, whereby it can be declared in conformity with all relevant Directives.

Certified:



Tom Langworthy
Engineering Director
8111 Lyndale Ave. South
Bloomington, MN 55420, USA
September 22, 2022

Authorized Representative:

Marcel Dutrieux
Manager European Product Integrity
Toro Europe NV
Nijverheidsstraat 5
2260 Oevel
Belgium

UK Declaration of Incorporation

The Toro Company, 8111 Lyndale Ave. South, Bloomington, MN, USA declares that the following unit(s) conform(s) to the directives listed, when installed in accordance with the accompanying instructions onto certain Toro models as indicated on the relevant Declarations of Conformity.

Model No.	Serial No.	Product Description	Invoice Description	General Description	Directive
01005	403460001 and Up	Reelmaster 5-Blade Reel Mower	REELMASTER 5	Reelmaster 5-Blade Reel Mower	S.I. 2008 No. 1597
01007	403460001 and Up	Reelmaster 7-Blade Reel Mower	REELMASTER 7	Reelmaster 7-Blade Reel Mower	S.I. 2008 No. 1597
01011	403460001 and Up	Reelmaster 11-Blade Reel Mower	REELMASTER 11	Reelmaster 11-Blade Reel Mower	S.I. 2008 No. 1597

Relevant technical documentation has been compiled as required per Schedule 10 of S.I. 2008 No. 1597.

We will undertake to transmit, in response to requests by national authorities, relevant information on this partly completed machinery. The method of transmission shall be electronic transmittal.

This machinery shall not be put into service until incorporated into approved Toro models as indicated on the associated Declaration of Conformity and in accordance with all instructions, whereby it can be declared in conformity with all relevant Regulations.

This declaration has been issued under the sole responsibility of the manufacturer.
The object of the declaration is in conformity with relevant UK legislation.



Tom Langworthy
Engineering Director
8111 Lyndale Ave. South
Bloomington, MN 55420, USA
September 22, 2022

Authorized Representative:

Marcel Dutrieux
Manager European Product Integrity
Toro U.K. Limited
Spellbrook Lane West
Bishop's Stortford
CM23 4BU
United Kingdom

EEA/UK Privacy Notice

Toro's Use of Your Personal Information

The Toro Company ("Toro") respects your privacy. When you purchase our products, we may collect certain personal information about you, either directly from you or through your local Toro company or dealer. Toro uses this information to fulfil contractual obligations - such as to register your warranty, process your warranty claim or to contact you in the event of a product recall - and for legitimate business purposes - such as to gauge customer satisfaction, improve our products or provide you with product information which may be of interest. Toro may share your information with our subsidiaries, affiliates, dealers or other business partners in connection these activities. We may also disclose personal information when required by law or in connection with the sale, purchase or merger of a business. We will never sell your personal information to any other company for marketing purposes.

Retention of your Personal Information

Toro will keep your personal information as long as it is relevant for the above purposes and in accordance with legal requirements. For more information about applicable retention periods please contact legal@toro.com.

Toro's Commitment to Security

Your personal information may be processed in the US or another country which may have less strict data protection laws than your country of residence. Whenever we transfer your information outside of your country of residence, we will take legally required steps to ensure that appropriate safeguards are in place to protect your information and to make sure it is treated securely.

Access and Correction

You may have the right to correct or review your personal data, or object to or restrict the processing of your data. To do so, please contact us by email at legal@toro.com. If you have concerns about the way in which Toro has handled your information, we encourage you to raise this directly with us. Please note that European residents have the right to complain to your Data Protection Authority.



The Toro Warranty

Two-Year or 1,500 Hours Limited Warranty

Conditions and Products Covered

The Toro Company and its affiliate, Toro Warranty Company, pursuant to an agreement between them, jointly warrant your Toro Commercial product ("Product") to be free from defects in materials or workmanship for 2 years or 1,500 operational hours*, whichever occurs first. This warranty is applicable to all products with the exception of Aerators (refer to separate warranty statements for these products). Where a warrantable condition exists, we will repair the Product at no cost to you including diagnostics, labor, parts, and transportation. This warranty begins on the date the Product is delivered to the original retail purchaser.

* Product equipped with an hour meter.

Instructions for Obtaining Warranty Service

You are responsible for notifying the Commercial Products Distributor or Authorized Commercial Products Dealer from whom you purchased the Product as soon as you believe a warrantable condition exists. If you need help locating a Commercial Products Distributor or Authorized Dealer, or if you have questions regarding your warranty rights or responsibilities, you may contact us at:

Toro Commercial Products Service Department
Toro Warranty Company
8111 Lyndale Avenue South
Bloomington, MN 55420-1196
952-888-8801 or 800-952-2740
E-mail: commercial.warranty@toro.com

Owner Responsibilities

As the product owner, you are responsible for required maintenance and adjustments stated in your *Operator's Manual*. Repairs for product issues caused by failure to perform required maintenance and adjustments are not covered under this warranty.

Items and Conditions Not Covered

Not all product failures or malfunctions that occur during the warranty period are defects in materials or workmanship. This warranty does not cover the following:

- Product failures which result from the use of non-Toro replacement parts, or from installation and use of add-on, or modified non-Toro branded accessories and products.
- Product failures which result from failure to perform recommended maintenance and/or adjustments.
- Product failures which result from operating the Product in an abusive, negligent, or reckless manner.
- Parts consumed through use that are not defective. Examples of parts which are consumed, or used up, during normal Product operation include, but are not limited to, brake pads and linings, clutch linings, blades, reels, rollers and bearings (sealed or greasable), bed knives, spark plugs, castor wheels and bearings, tires, filters, belts, and certain sprayer components such as diaphragms, nozzles, and check valves.
- Failures caused by outside influence, including, but not limited to, weather, storage practices, contamination, use of unapproved fuels, coolants, lubricants, additives, fertilizers, water, or chemicals.
- Failure or performance issues due to the use of fuels (e.g. gasoline, diesel, or biodiesel) that do not conform to their respective industry standards.
- Normal noise, vibration, wear and tear, and deterioration. Normal "wear and tear" includes, but is not limited to, damage to seats due to wear or abrasion, worn painted surfaces, scratched decals or windows.

Countries Other than the United States or Canada

Customers who have purchased Toro products exported from the United States or Canada should contact their Toro Distributor (Dealer) to obtain guarantee policies for your country, province, or state. If for any reason you are dissatisfied with your Distributor's service or have difficulty obtaining guarantee information, contact your Authorized Toro Service Center.

Parts

Parts scheduled for replacement as required maintenance are warranted for the period of time up to the scheduled replacement time for that part. Parts replaced under this warranty are covered for the duration of the original product warranty and become the property of Toro. Toro will make the final decision whether to repair any existing part or assembly or replace it. Toro may use remanufactured parts for warranty repairs.

Deep Cycle and Lithium-Ion Battery Warranty

Deep cycle and Lithium-Ion batteries have a specified total number of kilowatt-hours they can deliver during their lifetime. Operating, recharging, and maintenance techniques can extend or reduce total battery life. As the batteries in this product are consumed, the amount of useful work between charging intervals will slowly decrease until the battery is completely worn out. Replacement of worn out batteries, due to normal consumption, is the responsibility of the product owner. Note: (Lithium-Ion battery only): Pro-rated after 2 years. Refer to the battery warranty for additional information.

Lifetime Crankshaft Warranty (ProStripe 02657 Model Only)

The ProStripe which is fitted with a genuine Toro Friction Disc and Crank-Safe Blade Brake Clutch (integrated Blade Brake Clutch (BBC) + Friction Disc assembly) as original equipment and used by the original purchaser in accordance with recommended operating and maintenance procedures, are covered by a Lifetime Warranty against engine crankshaft bending. Machines fitted with friction washers, Blade Brake Clutch (BBC) units and other such devices are not covered by the Lifetime Crankshaft Warranty.

Maintenance is at Owner's Expense

Engine tune-up, lubrication, cleaning and polishing, replacement of filters, coolant, and completing recommended maintenance are some of the normal services Toro products require that are at the owner's expense.

General Conditions

Repair by an Authorized Toro Distributor or Dealer is your sole remedy under this warranty.

Neither The Toro Company nor Toro Warranty Company is liable for indirect, incidental or consequential damages in connection with the use of the Toro Products covered by this warranty, including any cost or expense of providing substitute equipment or service during reasonable periods of malfunction or non-use pending completion of repairs under this warranty. Except for the Emissions warranty referenced below, if applicable, there is no other express warranty. All implied warranties of merchantability and fitness for use are limited to the duration of this express warranty.

Some states do not allow exclusions of incidental or consequential damages, or limitations on how long an implied warranty lasts, so the above exclusions and limitations may not apply to you. This warranty gives you specific legal rights, and you may also have other rights which vary from state to state.

Note Regarding Emissions Warranty

The Emissions Control System on your Product may be covered by a separate warranty meeting requirements established by the U.S. Environmental Protection Agency (EPA) and/or the California Air Resources Board (CARB). The hour limitations set forth above do not apply to the Emissions Control System Warranty. Refer to the Engine Emission Control Warranty Statement supplied with your product or contained in the engine manufacturer's documentation.