



170-DH

Lawn Tractor

Model No. 74570—220000001 and Up

Operator's Manual



Important The engine in this product is not equipped with a spark arrester muffler. In some areas it is a violation of the law to use or operate this engine on any forest-covered, brush-covered, or grass-covered land.

This spark ignition system complies with Canadian ICES-002.

Ce système d'allumage par étincelle de véhicule est conforme à la norme NMB-002 du Canada.

Contents

	Page
Introduction	2
Safety	3
Safe Operation Practices for Ride-on (riding) Rotary Lawnmower Machine	3
Safe Operating Practices	3
Toro Riding Mower Safety	5
Sound Pressure Level	5
Sound Power Level	5
Vibration Level	5
Slope Chart	7
Safety and Instruction Decals	9
Gasoline and Oil	11
Recommended Gasoline	11
Stabilizer/Conditioner	11
Filling the Fuel Tank	12
Checking the Engine Oil Level	12
Operation	12
Think Safety First	12
Controls	12
Parking Brake	12
Positioning the Seat	13
Headlights	13
Using the Blade Control (PTO)	13
Grass Collector Warning Light	13
Setting the Height of Cut	14
Discharge Baffle	14
Adjusting the Mower Gauge Wheels	14
Starting and Stopping the Engine	14
The Safety Interlock System	15
Testing the Safety System	16
Pushing the Machine by Hand	17
Driving Forward or Backward	17
Stopping the Machine	17
Emptying the Grass Collector	18
Towing Attachments	18
Tips for Mowing Grass	18

	Page
Maintenance	19
Recommended Maintenance Schedule	19
Engine Oil	20
Brake	22
Tire Pressure	22
Greasing and Lubrication	22
Fuse	24
Headlights	24
Battery	25
Spark Plug	26
Draining the Fuel Tank	27
Fuel Filter	27
Air Cleaner	28
Cutting Blade	29
Removing the Mower	30
Installing the Mower	31
Adjusting the Blade Drive Belt	31
Adjusting the Height Adjustment Cable Rod Assembly	31
Grass Collector	32
Cleaning and Storage	32
Troubleshooting	33

Introduction

Read this manual carefully to learn how to operate and maintain your product properly. The information in this manual can help you and others avoid injury and product damage. Although Toro designs and produces safe products, you are responsible for operating the product properly and safely.

Whenever you need service, genuine Toro parts, or additional information, contact an Authorized Service Dealer or Toro Customer Service and have the model and serial numbers of your product ready. Figure 1 illustrates the location of the model and serial numbers on the product.

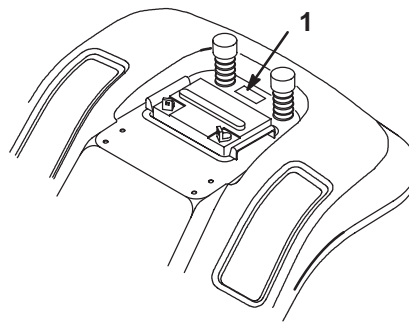

Figure 1

1. Location of the model and serial numbers

Write the product model and serial numbers in the space below:

Model No. _____
Serial No. _____

This manual identifies potential hazards and has special safety messages that help you and others avoid personal injury and even death. **Danger**, **Warning**, and **Caution** are signal words used to identify the level of hazard. However, regardless of the hazard, be extremely careful.

Danger signals an extreme hazard that *will* cause serious injury or death if you do not follow the recommended precautions.

Warning signals a hazard that *may* cause serious injury or death if you do not follow the recommended precautions.

Caution signals a hazard that may cause minor or moderate injury if you do not follow the recommended precautions.

This manual uses two other words to highlight information.

Important calls attention to special mechanical information and **Note**: emphasizes general information worthy of special attention.

Safety

Safe Operation Practices for Ride-on (riding) Rotary Lawnmower Machine

This machine meets or exceeds European Standards in effect at the time of production. However, improper use or maintenance by the operator or owner can result in injury. To reduce the potential for injury, comply with these safety instructions and always pay attention to the safety alert **▲** symbol, which means CAUTION, WARNING, or DANGER—“personal safety instruction.” Failure to comply with the instruction may result in personal injury or death.

Safe Operating Practices

The following instructions are from the CEN standard EN 836:1997.

This product is capable of amputating hands and feet and throwing objects. Always follow all safety instructions to avoid serious injury or death.

Training

- Read the instructions carefully. Be familiar with the controls and the proper use of the equipment.
- Never allow children or people unfamiliar with these instructions to use the lawnmower. Local regulations can restrict the age of the operator.
- Never mow while people, especially children, or pets are nearby.
- Keep in mind that the operator or user is responsible for accidents or hazards occurring to other people or their property.
- Do not carry passengers.
- All drivers should seek and obtain professional and practical instruction. Such instruction should emphasize:
 - the need for care and concentration when working with ride-on machines;
 - control of a ride-on machine sliding on a slope will not be regained by the application of the brake. The main reasons for loss of control are:
 - insufficient wheel grip;
 - being driven too fast;
 - inadequate braking;
 - the type of machine is unsuitable for its task;
 - lack of awareness of the effect of ground conditions, especially slopes;
 - incorrect hitching and load distribution.

Preparation

- While mowing, always wear substantial footwear and long trousers. Do not operate the equipment when barefoot or wearing open sandals.
- Thoroughly inspect the area where the equipment is to be used and remove all objects which may be thrown by the machine.
- WARNING – Fuel is highly flammable.
 - Store fuel in containers specifically designed for this purpose.
 - Refuel outdoors only and do not smoke while refuelling.
 - Add fuel before starting the engine. Never remove the cap of the fuel tank or add fuel while the engine is running or when the engine is hot.

- If fuel is spilled, do not attempt to start the engine but move the machine away from the area of spillage and avoid creating any source of ignition until fuel vapors have dissipated.
- Replace all fuel tanks and container caps securely.
- Replace faulty silencers.
- Before using, always visually inspect to see that the blades, blade bolts and cutter assembly are not worn or damaged. Replace worn or damaged blades and bolts in sets to preserve balance.
- On multi-bladed machines, take care as rotating one blade can cause other blades to rotate.

Operation

- Do not operate the engine in a confined space where dangerous carbon monoxide fumes can collect.
- Mow only in daylight or in good artificial light.
- Before attempting to start the engine, disengage all blade attachment clutches and shift into neutral.
- Do not use on slopes of more than
 - 5° when mowing on side hills;
 - 10° when mowing uphill;
 - 15° when mowing downhill.
- Remember there is no such thing as a “safe” slope. Travel on grass slopes requires particular care. To guard against overturning:
 - do not stop or start suddenly when going up or downhill;
 - engage clutch slowly, always keep machine in gear, especially when travelling downhill;
 - machine speeds should be kept low on slopes and during tight turns;
 - stay alert for humps and hollows and other hidden hazards;
 - never mow across the face of the slope, unless the lawnmower is designed for this purpose.
- Use care when pulling loads or using heavy equipment.
 - Use only approved drawbar hitch points.
 - Limit loads to those you can safely control.
 - Do not turn sharply. Use care when reversing.
 - Use counterweight(s) or wheel weights when suggested in the instruction handbook.
- Watch out for traffic when crossing or near roadways.
- Stop the blades rotating before crossing surfaces other than grass.
- When using any attachments, never direct discharge of material toward bystanders nor allow anyone near the machine while in operation.
- Never operate the machine with defective guards or without safety protective devices in place.
- Do not change the engine governor settings or overspeed the engine. Operating the engine at excessive speed can increase the hazard of personal injury.
- Before leaving the operator’s position:
 - disengage the power take-off and lower the attachments;
 - change into neutral and set the parking brake;
 - stop the engine and remove the key.
- Disengage drive to attachments, stop the engine, and disconnect the spark plug wire(s) or remove the ignition key
 - before clearing blockages or unclogging chute;
 - before checking, cleaning or working on the lawnmower;
 - after striking a foreign object. Inspect the lawnmower for damage and make repairs before restarting and operating the equipment;
 - if the machine starts to vibrate abnormally (check immediately).
- Disengage drive to attachments when transporting or not in use.
- Stop the engine and disengage drive to attachment
 - before refuelling;
 - before removing the grass catcher;
 - before making height adjustment unless adjustment can be made from the operator’s position.
- Reduce the throttle setting during engine run-out and, if the engine is provided with a shut-off valve, turn the fuel off at the conclusion of mowing.

Maintenance and Storage

- Keep all nuts, bolts and screws tight to be sure the equipment is in safe working condition.
- Never store the equipment with fuel in the tank inside a building where fumes can reach an open flame or spark.
- Allow the engine to cool before storing in any enclosure.

- To reduce the fire hazard, keep the engine, silencer, battery compartment and fuel storage area free of grass, leaves, or excessive grease.
- Check the grass catcher frequently for wear or deterioration.
- Replace worn or damaged parts for safety.
- If the fuel tank has to be drained, this should be done outdoors.
- On multi-bladed machines, take care as rotating one blade can cause other blades to rotate.
- When machine is to be parked, stored or left unattended, lower the cutting means unless a positive mechanical lock is used.

Toro Riding Mower Safety

The following list contains safety information specific to Toro products or other safety information that you must know that is not included in the CEN standard.

- Use only Toro-approved attachments. Warranty may be voided if used with unapproved attachments.

Sound Pressure Level

This unit has an equivalent continuous A-weighted sound pressure at the operator ear of: 79 dB(A), based on measurements of identical machines as directed by 98/37/EC.

Sound Power Level

This unit has a sound power level of: 100 Lwa, based on measurements of identical machines as directed by 2000/14/EC.

Vibration Level

This unit has a maximum hand-arm vibration level of 3.59 m/s² and whole body vibration level of 1.13 m/s², based on measurements of identical machines as directed by 98/37/EC.

Slope Chart

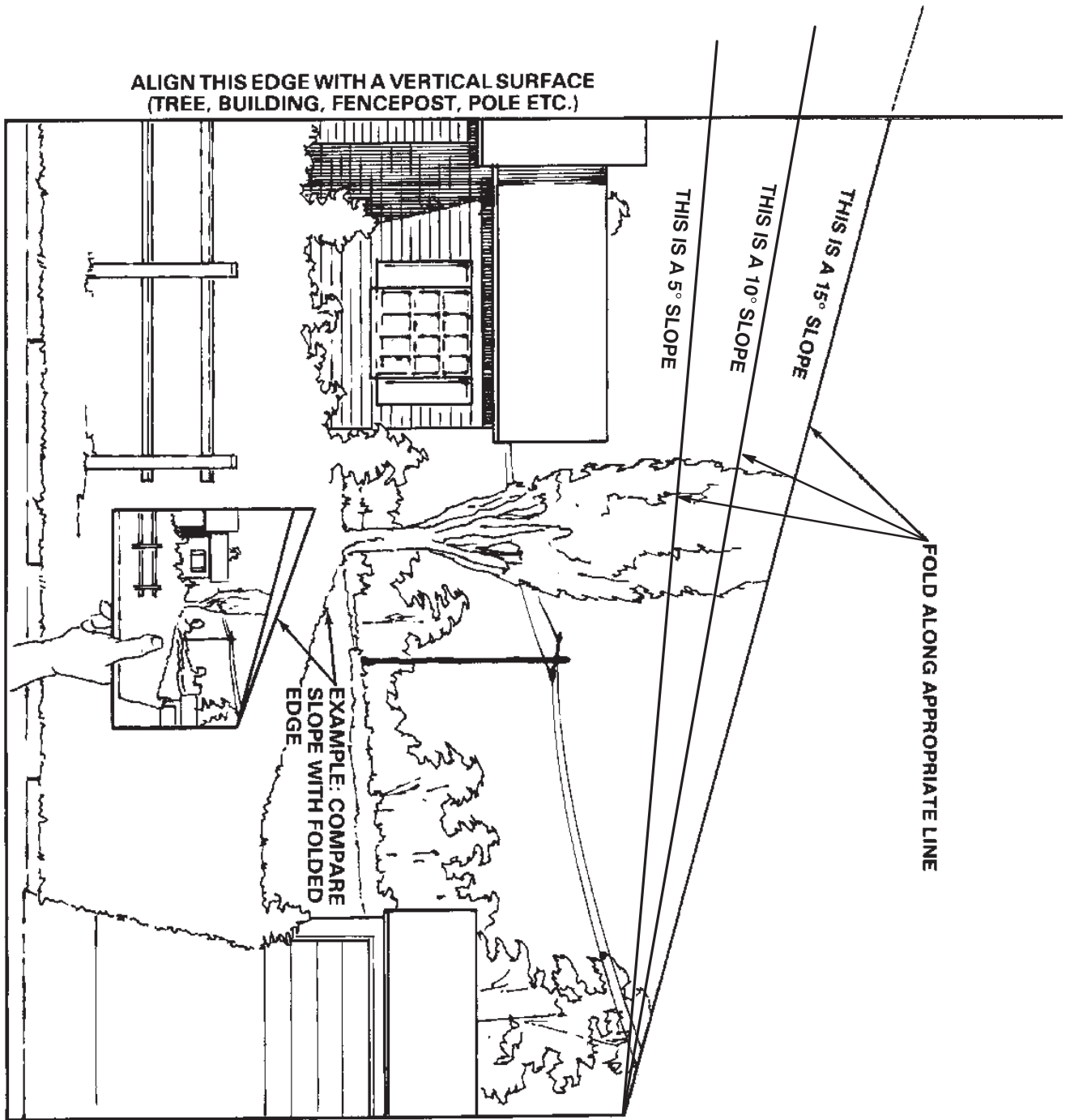

Safety and Instruction Decals



Safety decals and instructions are easily visible to the operator and are located near any area of potential danger. Replace any decal that is damaged or lost.



99-7824

1. Thrown object hazard—keep bystanders away.
2. Thrown object hazard from mower—keep the deflector in place.
3. Cutting/dismemberment hazard of hands or feet—stay away from rotating blades and moving parts.



93-7276

1. Explosive hazard—wear eye protection.
2. Caustic liquid hazard—if contact occurs, flush with water.
3. Fire or open flame hazard—no sparks, flame, or smoking.
4. Toxic risk—keep children away from the battery.



104-3237

1. Parking brake

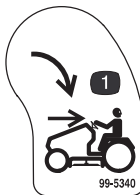

99-5340

1. Key Choice™ switch



104-3194

1. Crushing/dismemberment hazard—look back and down while backing up.
2. Parking brake
3. Full grass bag indicator
4. PTO (Power Take Off)

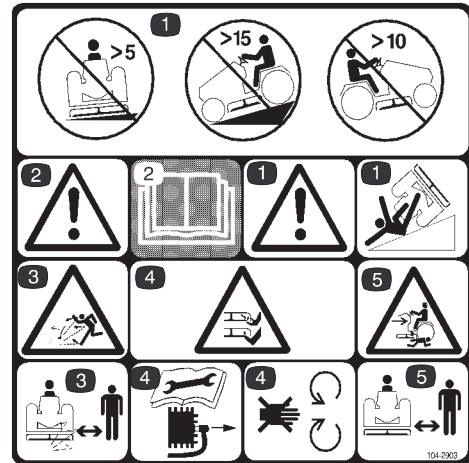

104-2903

1. Tipping hazard—do not go across slopes greater than 5 degrees, down slopes greater than 15 degrees, or up slopes greater than 10 degrees.
2. Danger—read the operator's manual.
3. Thrown object hazard—keep bystanders away.
4. Cutting/dismemberment hazard of hands or feet—stay away from rotating blades and moving parts. Pull the wire off of the spark plug before performing any maintenance.



104-3239

1. Heights of cut



104-3240

1. Decrease height of cut
2. Increase height of cut



104-3243

1. To drive the mower, push the lever in.
2. To push the mower, pull the lever out.

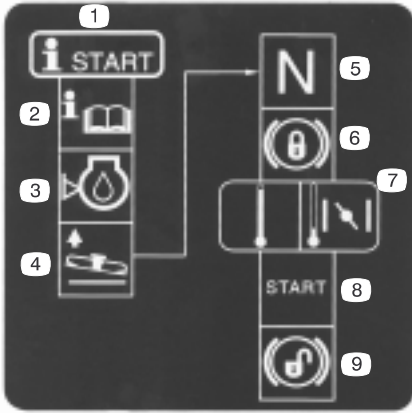

104-3238

1. Starting procedure
2. Read the operator's manual.
3. Check the engine oil level.
4. Raise the cutting unit.
5. Put the traction control pedal in neutral.
6. Set the parking brake.
7. If the engine is cold, move the throttle lever to Choke.
8. Turn the ignition key to start the engine.
9. Unlock the parking brake.

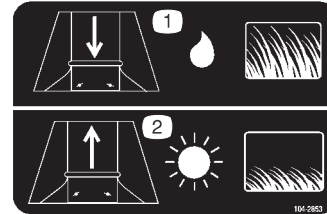

104-2853

1. Increase the discharge opening when mowing long, wet grass.
2. Decrease the discharge opening when mowing short, dry grass.



104-3241

1. Forward
2. Neutral
3. Variable speed from slow to fast
4. Reverse



104-3235

1. Pull up to engage.
2. Push in to disengage.
3. Power Take Off (PTO)



104-3236

- | | |
|-------------------------------------|------------------|
| 1. Choke | 4. Headlights on |
| 2. Variable speed from slow to fast | 5. Engine on |
| 3. Engine stop | 6. Engine start |

Gasoline and Oil

Recommended Gasoline

Use unleaded regular gasoline suitable for automotive use (85 pump octane minimum). Leaded regular gasoline may be used if unleaded regular is not available.

Important Never use methanol, gasoline containing methanol, or gasohol containing more than 10% ethanol because the fuel system could be damaged. Do not mix oil with gasoline.

⚠ ⚠ **Danger**

In certain conditions, gasoline is extremely flammable and highly explosive. A fire or explosion from gasoline can burn you and others and can damage property.

- Fill the fuel tank outdoors, in an open area, when the engine is cold. Wipe up any gasoline that spills.
- Do not fill the fuel tank completely full. Add gasoline to the fuel tank until the level is 1/4 to 1/2 in. (6 to 13 mm) below the bottom of the filler neck. This empty space in the tank allows gasoline to expand.
- Never smoke when handling gasoline, and stay away from an open flame or where gasoline fumes may be ignited by a spark.
- Store gasoline in an approved container and keep it out of the reach of children. Never buy more than a 30-day supply of gasoline.
- Always place gasoline containers on the ground away from your vehicle before filling.
- Do not fill gasoline containers inside a vehicle or on a truck or trailer bed because interior carpets or plastic truck bed liners may insulate the container and slow the loss of any static charge.
- When practical, remove gas-powered equipment from the truck or trailer and refuel the equipment with its wheels on the ground.
- If this is not possible, then refuel such equipment on a truck or trailer from a portable container, rather than from a gasoline dispenser nozzle.
- If a gasoline dispenser nozzle must be used, keep the nozzle in contact with the rim of the fuel tank or container opening at all times until fueling is complete.

Stabilizer/Conditioner

Using a stabilizer/conditioner in the machine:

- Keeps gasoline fresh during storage of 90 days or less. For longer storage it is recommended that the fuel tank be drained.
- Cleans the engine while it runs
- Eliminates gum-like varnish buildup in the fuel system, which causes hard starting

Important Never use fuel additives containing methanol or ethanol.

Add the correct amount of gas stabilizer/conditioner to the gas.

Note: A fuel stabilizer/conditioner is most effective when mixed with fresh gasoline. To minimize the chance of varnish deposits in the fuel system, use fuel stabilizer at all times.

Filling the Fuel Tank

1. Shut the engine off and set the parking brake. Allow the engine to cool for two minutes.
2. Clean around fuel tank cap and remove the cap. Add unleaded regular gasoline to the fuel tank, until the level is 6 to 13 mm (1/4 to 1/2 in.) below the bottom of the filler neck. This space in the tank allows the gasoline to expand. Do not fill the fuel tank completely full.
3. Install fuel tank cap securely. Wipe up any gasoline that may have spilled.

Checking the Engine Oil Level

Before you start the engine and use the machine, check the oil level in the engine crankcase; refer to Checking the Oil Level, page 20.

Operation

Note: Determine the left and right sides of the machine from the normal operating position.

Think Safety First

Please carefully read all of the safety instructions and decals in the safety section. Knowing this information could help you, your family, pets, or bystanders avoid injury.

Controls

Become familiar with all of the controls (Fig. 2) before you start the engine and operate the machine.

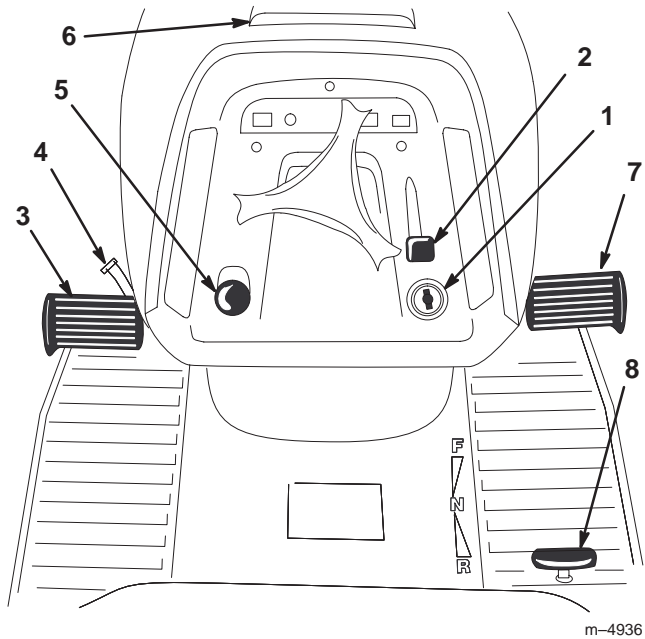

Figure 2

- | | |
|--------------------------|------------------------|
| 1. Ignition/light switch | 5. Blade control (PTO) |
| 2. Throttle/Choke lever | 6. Hood opening |
| 3. Brake pedal | 7. Forward speed pedal |
| 4. Parking brake lever | 8. Reverse speed pedal |

Parking Brake

Always set the parking brake when you stop the machine or leave it unattended.

Setting the Parking Brake

1. Push the brake pedal (Fig. 2) down and hold it in the depressed position.
2. Turn the parking brake lever (Fig. 2) counterclockwise and gradually take your foot off of the brake pedal. The brake pedal should stay in the depressed (locked) position.

Note: The parking brake light on the dash will turn on when the parking brake is engaged (Fig. 5).

Releasing the Parking Brake

1. Push down on the brake pedal (Fig. 2). The parking brake lever should release.
2. Gradually release the brake pedal.

Positioning the Seat

The seat can move forward and backward. Position the seat where you have the best control of the machine and are most comfortable.

1. Raise the seat and loosen the adjustment knobs (Fig. 3).
2. Move the seat to the desired position and tighten the adjustment knobs.

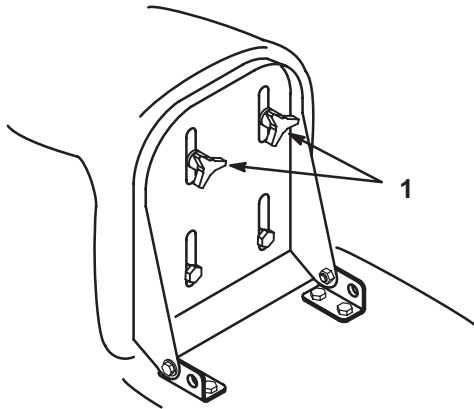

Figure 3

m-4841

1. Adjustment knobs

Headlights

The headlights are an integral function of the ignition switch. Turn the ignition key clockwise to the Lights position.

Using the Blade Control (PTO)

The blade control (PTO) engages and disengages power to the blade(s).

Engaging the Blade(s)

1. Depress the brake pedal to stop the machine.
2. Pull the blade control (PTO) out to Engaged (Fig. 4).

Note: The PTO light on the dash will turn on when the PTO is engaged (Fig. 5).

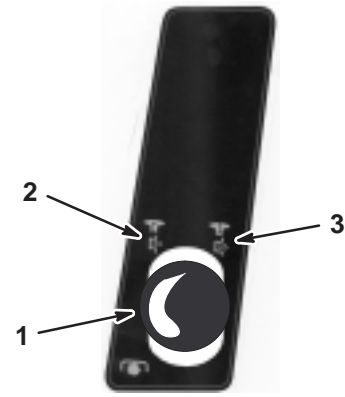

Figure 4

1. Blade control (PTO)
2. Engaged
3. Disengaged

Disengaging the Blade(s)

1. Depress the brake pedal to stop the machine.
2. Push the PTO in to Disengaged (Fig. 4).

Grass Collector Warning Light

When the grass collector is full and needs to be emptied, the warning light will come on (Fig. 5) and a buzzer will sound.

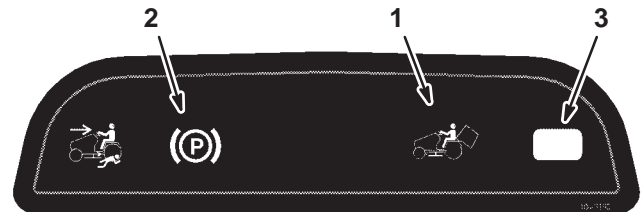

Figure 5

1. Grass collector warning light
2. Parking brake light
3. PTO light

Important To prevent the discharge tunnel from getting clogged, disengage the PTO when the warning light and buzzer are activated.

Setting the Height of Cut

The height-of-cut lever (deck lift) is used to raise and lower the mower to the desired cutting height.

The cutting height may be set in one of seven positions from approximately 25 to 102 mm (1 to 4 inches). Pull or push the height-of-cut lever (deck lift) and move it to the desired position (Fig. 6).

Important The height-of-cut lever must be in the highest position (7) when you are in transport mode (off of the lawn) to prevent damage to the cutting blades.

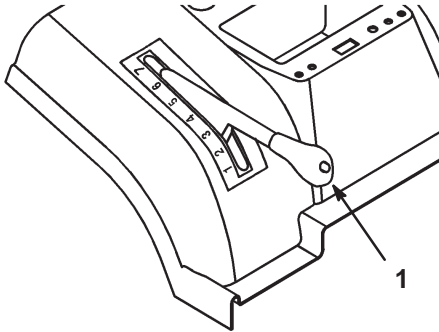

Figure 6

1. Height-of-cut lever (deck lift)

Discharge Baffle

The discharge baffle changes the size of the discharge opening to aid the bag fill indicator operation.

1. Remove the grass collector; refer to Removing the Grass Collector, page 32.
2. Loosen the 2 nuts on the mowing conditions plate and slide the plate up if you are mowing short, dry grass or down if you are mowing long, wet grass (Fig. 7). Tighten the nuts.
3. Install the grass collector; refer to Installing the Grass Collector, page 32.

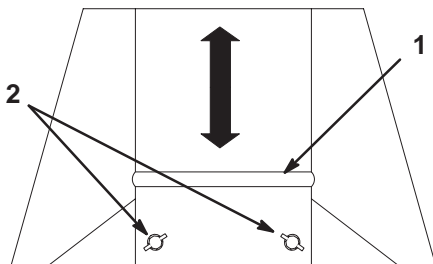

Figure 7

1. Plate
2. Nuts

Adjusting the Mower Gauge Wheels

The mower front gauge wheels are used to guide the mower over uneven ground. The mower wheels must always be in the bottom (lowest) hole in the wheel bracket (Fig. 8).

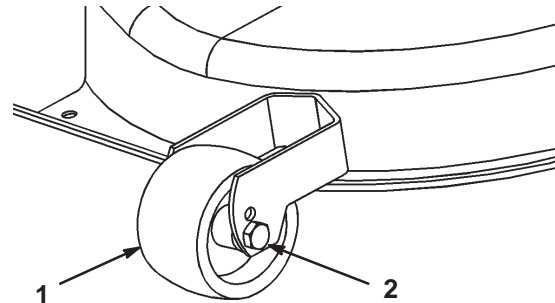

Figure 8

1. Wheel
2. Bottom hole

Starting and Stopping the Engine

Starting

1. Open the fuel shut-off valve (Fig. 9) located between the fuel tank and the engine. The handle should align with the fuel hose.

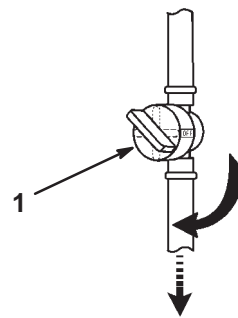

Figure 9

1. Fuel shut-off valve

2. Sit down on the seat.
3. Set the parking brake; refer to Setting the Parking Brake, page 12.

Note: The engine will not start unless you set the parking brake or fully depress the brake pedal.

4. Disengage the PTO (Fig. 10).

Note: The engine will not start if the PTO is engaged.

5. When starting a cold engine, move the throttle lever to the Choke position (Fig. 11).

Note: To start a warm engine, move the throttle lever to the Fast position.

- Turn the ignition key clockwise and hold it in the Start position (Fig. 11). When the engine starts, release the key.

Important If the engine does not start after 15 seconds of continuous cranking, turn the ignition key to Off and let the starter motor cool for two minutes; refer to Troubleshooting, page 33.

- After the engine starts, slowly move the throttle to Fast (Fig. 11).

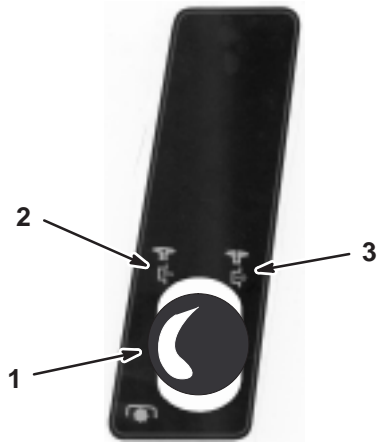

Figure 10

- | | |
|------------------------|---------------|
| 1. Blade control (PTO) | 3. Disengaged |
| 2. Engaged | |

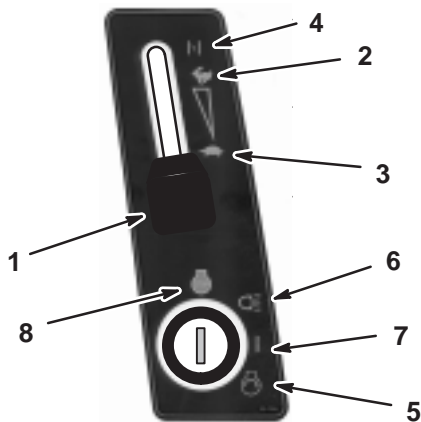

Figure 11

- | | |
|---------------------|-----------|
| 1. Throttle control | 5. Start |
| 2. Fast | 6. Lights |
| 3. Slow | 7. On |
| 4. Choke | 8. Off |

Stopping

- Move the throttle lever to Slow (Fig. 11).

Important To prevent backfiring and damage to the engine, do not move the throttle lever to Choke or Fast to stop the engine.

- Turn the ignition key to Off (Fig. 11).

Note: If the engine has been working hard or is hot, let it idle for a minute before turning the ignition key Off. This helps cool the engine before it is stopped. In an emergency, the engine may be stopped by turning the ignition key to Off.

The Safety Interlock System

⚠
Caution
⚠

If safety interlock switches are disconnected or damaged the machine could operate unexpectedly causing personal injury.

- Do not tamper with the interlock switches.
- Check the operation of the interlock switches daily and replace any damaged switches before operating the machine.
- Replace switches every two years regardless of whether they are operating properly or not.

Understanding the Safety Interlock System

The safety interlock system is designed to prevent the engine from starting unless:

- You are sitting on the seat.
- The brake pedal is depressed.
- The PTO is Disengaged.
- The traction control pedal is in Neutral.

The safety interlock system is designed to stop the engine if you rise from the seat and the traction control pedal is not in Neutral, the parking brake is not set, and/or the PTO is engaged.

The safety interlock system is designed to stop the mower deck if:

- You shift into reverse with the PTO engaged.
- You remove the bag or dump grass.

Setting the KeyChoice™ Switch to Operate in Reverse

An interlock feature on the tractor prevents the power take off (PTO) from operating when backing up. If you shift into reverse with the PTO engaged (i.e., with mower blades or other attachment running), the engine will stop. **Do not mow in reverse unless absolutely necessary.**

If you need to use the PTO while backing up, you can turn off this interlock feature using the KeyChoice switch located near the seat bracket (Fig. 12).

Danger

You could back over a child or bystander while the mower blade(s) or other attachment is engaged and cause serious injury or death.

- **Do not mow in reverse unless absolutely necessary.**
- **Do not insert the KeyChoice key unless it is absolutely necessary.**
- **Always look backward and down before backing up.**
- **Use the KeyChoice switch only if you are certain no children or other bystanders will enter the mowing area.**
- **Be very observant after deactivating the interlock because the sound of the engine may prevent you from noticing that a child or bystander has entered the work area.**
- **Always remove both the ignition and KeyChoice keys and put them in a safe place out of the reach of children or unauthorized users when leaving the unit unattended.**

1. Engage the PTO.
2. Insert the KeyChoice key into the switch (Fig. 12).

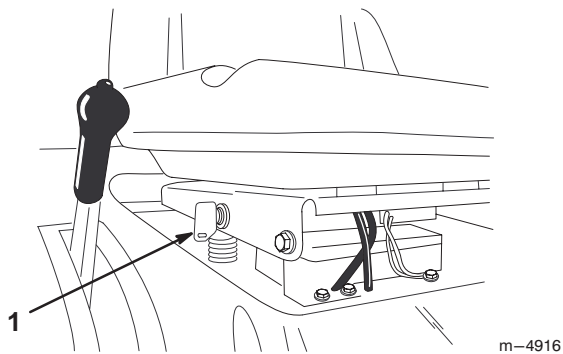

Figure 12

1. KeyChoice switch

3. Turn the KeyChoice key.

A red light on the front console (Fig. 13) turns on, indicating that the interlock is disabled.



Figure 13

1. Operating-in-reverse light

4. Shift into reverse and complete your task.
5. Stop the PTO to activate the interlock.
6. Remove the KeyChoice key and put it in a safe place out of reach of children.

Testing the Safety System

Test the safety system before you use the machine each time. If the safety system does not operate as described below, have an Authorized Service Dealer repair the safety system immediately. While sitting in the seat, perform the following checks.

1. Set the parking brake. Move the PTO to Engaged. Turn the ignition key to Start; the engine should not crank.
2. Move the PTO to Disengaged and release the parking brake. Turn the ignition key to Start; the engine should not crank.
3. Set the parking brake and move the PTO to Disengaged. Start the engine. While the engine is running, release the parking brake and rise slightly from the seat; the engine should stop.
4. Move the PTO to Disengaged and put the traction control pedal in Neutral. Start the engine. While the engine is running, move the PTO to Engaged and the traction control pedal to reverse. The mower deck should stop.
5. Move the PTO to Disengaged and put the traction control pedal in neutral. Start the engine. Move the PTO to Engaged and turn the KeyChoice key and release it. The operating-in-reverse warning light should illuminate. Move the PTO to Disengaged and the operating-in-reverse warning light should turn off.

Pushing the Machine by Hand

Important Always push the machine by hand. Never tow the machine because transaxle damage may occur.

To Push the Machine

1. Park the machine on a level surface, disengage the PTO, set the parking brake, stop the engine, and remove the ignition key.
2. Remove the grass collector; refer to Removing the Grass Collector, page 32.
3. Pull the drive control, located at the rear of the machine, out to the Push position and release the parking brake. This disengages the drive system and allows the wheels to turn freely (Fig. 14).

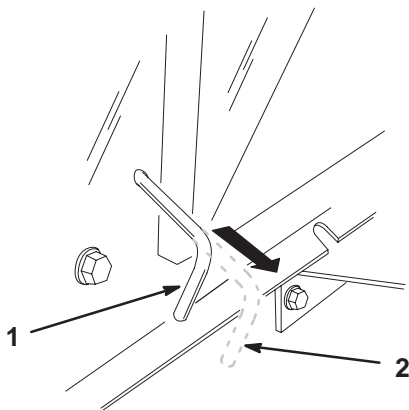

Figure 14

m-4933

1. Operate position
2. Push position

To Operate the Machine

1. Set the parking brake and push the drive control in to the Operate position. This engages the drive system (Fig. 14).

Note: The machine will not drive unless the drive control is in the Operate position.

2. Install the grass collector; refer to Installing the grass collector, page 32.

Driving Forward or Backward

The throttle control regulates the engine speed as measured in RPM (revolutions per minute). Place the throttle control in the Fast position for best performance.

To go forward, release the parking brake; refer to Releasing the Parking Brake, page 12. Place your foot on the traction control pedal and slowly press on the pedal to move

forward (Fig. 15). The farther you move the traction control pedal, the faster the machine will move forward. To slow down release the pressure on the traction control pedal.

To go backward, release the parking brake; refer to Releasing the Parking Brake, page 12. Place your foot on the reverse speed pedal and slowly press on the pedal to move backward (Fig. 15). The farther you move the reverse speed pedal, the faster the machine will move backward. To slow down release the pressure on the reverse speed pedal.

Important To avoid transmission damage, always release the parking brake before moving the traction control pedal or the reverse speed pedal.

Important To prevent damage to the mower, always put the mower in the highest cutting position when you drive the tractor off of the lawn.

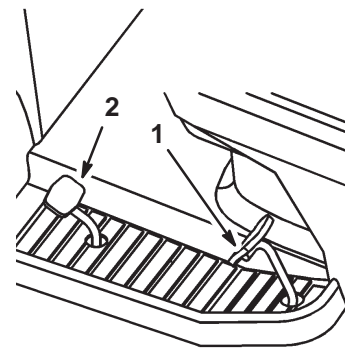

Figure 15

1. Traction control pedal
2. Reverse speed pedal

Stopping the Machine

To stop the machine, release the traction control pedal or reverse speed pedal, disengage the PTO, and turn the ignition key to Off to stop the engine. Also set the parking brake if you leave the machine unattended; refer to Setting the Parking Brake, page 12. Remember to remove the keys from the ignition and KeyChoice switches.



Caution



Children or bystanders may be injured if they move or attempt to operate the tractor while it is unattended.

Always remove the ignition and KeyChoice keys and set the parking brake when leaving the machine unattended, even if it is just for a few minutes.

Emptying the Grass Collector

When the collector warning light (Fig. 5) comes on and the buzzer sounds, the grass collector is full and must be emptied.

Important To prevent the discharge tunnel from getting clogged, the PTO must be disengaged when the warning light and buzzer are activated.

1. Disengage the PTO and move the throttle to Slow.
2. Pull out the telescoping dump lever and push it forward and down to empty the grass collector (Fig. 16).

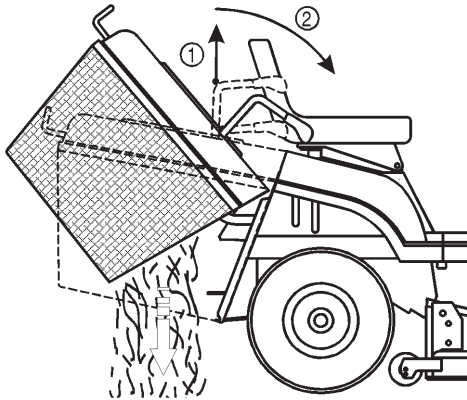

Figure 16

1. Pull up
2. Push forward and down

3. Slowly pull the dump lever upward to return the grass collector to the operating position.

Towing Attachments

The tractor is equipped for towing attachments with a maximum weight of 150 kg (331 lb.).

1. Remove the grass collector; refer to Removing the Grass Collector, page 32.
2. Install the attachment to the towing hitch located at the lower rear part of the tractor (Fig. 17).

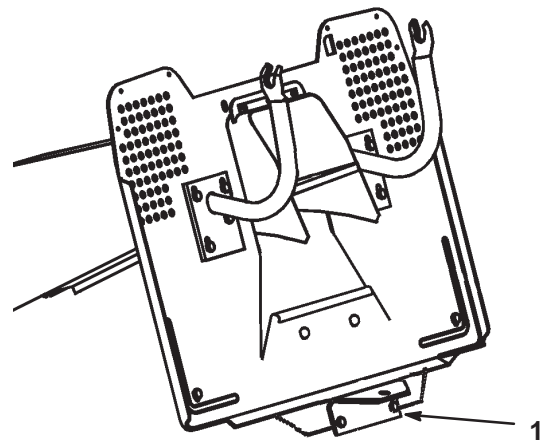

Figure 17

1. Towing hitch

Tips for Mowing Grass

Fast Throttle Setting

For best mowing and maximum air circulation, operate the engine at Fast. Air is required to thoroughly cut grass clippings, so do not set the height-of-cut too low or totally surround the mower by uncut grass. Always try to have one side of the mower free from uncut grass, which allows air to be drawn into the mower.

Cutting a Lawn for the First Time

Cut grass slightly longer than normal to ensure that the cutting height of the mower does not scalp any uneven ground. However, the cutting height used in the past is generally the best one to use. When cutting grass longer than 15 cm (6 in.) tall, you may want to cut the lawn twice to ensure an acceptable quality of cut.

Cut 1/3 of the Grass Blade

It is best to cut only about 1/3 of the grass blade. Cutting more than that is not recommended, unless grass is sparse or it is late fall when grass grows more slowly.

Mowing Direction

Alternate mowing direction to keep the grass standing straight. This also helps disperse clippings which enhances decomposition and fertilization.

Mow at Correct Intervals

Normally, mow every four days. But remember, grass grows at different rates at different times. So to maintain the same cutting height, which is a good practice, mow more often in early spring. As the grass growth rate slows in mid summer, mow less frequently. If you cannot mow for an extended period, first mow at a high cutting height; then mow again two days later at a lower height setting.

Avoid Cutting Too Low

If the cutting width of the mower is wider than the mower you previously used, raise the cutting height one notch to ensure uneven turf is not cut too short.

Long Grass

If the grass is ever allowed to grow slightly longer than normal, or if it contains a high degree of moisture, raise the cutting height higher than usual and cut the grass at this setting. Then cut the grass again using the lower, normal setting.

When Stopping

If the machine must be stopped while mowing, a clump of grass clippings may drop onto your lawn. To avoid this:

1. With the blade(s) Engaged, move onto a previously cut area.
2. To disperse the clippings evenly, raise the mower one or two height-of-cut settings while driving forward with the blade(s) Engaged.

Keep the Underside of the Mower Clean

Clean clippings and dirt from the underside of the mower after each use. If grass and dirt build up inside the mower, cutting quality will eventually become unsatisfactory.

Blade Maintenance

Maintain a sharp blade throughout the cutting season because a sharp blade cuts cleanly without tearing or shredding the grass blades. Tearing and shredding turns grass brown at the edges, which slows growth and increases the chance of disease. Every 30 days, check the cutter blade(s) for sharpness and file down any nicks.

Maintenance

Note: Determine the left and right sides of the machine from the normal operating position.

Recommended Maintenance Schedule

Maintenance Service Interval	Maintenance Procedure
After first use	<ul style="list-style-type: none">• Change the oil.
After first 20 hours	<ul style="list-style-type: none">• Check the blade drive belt adjustment.
Each use	<ul style="list-style-type: none">• Check the oil level.• Check the safety system.• Clean the mower housing.• Check the battery electrolyte level.• Check the tire pressure.• Check the cutting blade.• Check the brakes.
Every 25 hours	<ul style="list-style-type: none">• Grease the chassis.²• Service the foam air cleaner.²• Clean the outside of the engine.
Every 50 hours	<ul style="list-style-type: none">• Change the oil.¹• Adjust the blade drive belt.

Maintenance Service Interval	Maintenance Procedure
Every 100 hours	<ul style="list-style-type: none"> • Replace the oil filter. • Replace the paper air cleaner.² • Check the spark plug.
Before storage	<ul style="list-style-type: none"> • Perform all of the maintenance procedures listed above. • Check the belts for wear or cracks. • Drain the gasoline. • Paint chipped surfaces. • Charge the battery and disconnect the cables. • Replace the fuel filter.

¹Every 25 hours under heavy load or high ambient temperature

²More often in dusty, dirty conditions

Important Refer to your engine operator's manual for additional maintenance procedures.

! **Caution** !

If you leave the key in the ignition switch, someone could accidentally start the engine and seriously injure you or other bystanders.

Remove the key from the ignition and disconnect the wire from the spark plug before you do any maintenance. Set the wire aside so that it does not accidentally contact the spark plug.

Engine Oil

Service Interval/Specification

Change the oil:

- After the first 5 operating hours
- After every 50 operating hours

Note: Change the oil every 25 hours when operating the engine under heavy load or in high temperatures.

Oil Type: Detergent oil (API service SF, SG, or SH)

Crankcase Capacity: 1.9 liters (64 oz.)

Viscosity: See the table below

USE THESE SAE VISCOSITY OILS

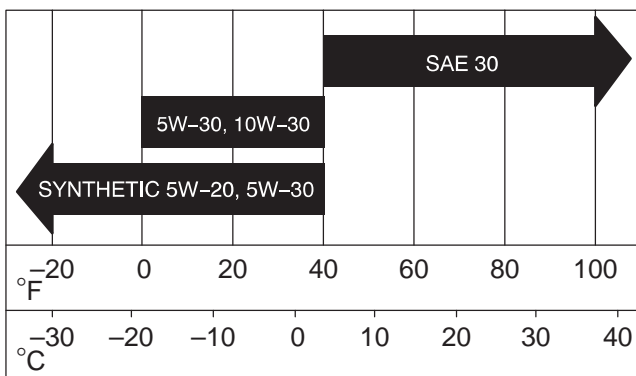

Checking the Oil Level

1. Park the machine on a level surface, disengage the PTO, set the parking brake, stop the engine, and remove the ignition key.
2. Open the hood.
3. Clean around the oil dipstick (Fig. 18) so dirt cannot fall into the filler hole and damage the engine.
4. Unscrew the oil dipstick and wipe the metal end clean (Fig. 18).
5. Screw the oil dipstick fully onto the filler tube (Fig. 18). Unscrew the dipstick again and look at the metal end. If the oil level is low, slowly pour only enough oil into the filler tube to raise the level to the Full mark. Tighten the dipstick.
6. Start and run the engine at idle for 30 seconds.
7. Shut the engine off and wait for 30 seconds. Check the oil level again and add oil if necessary.

Important Do not overfill the crankcase with oil because the engine may become damaged.

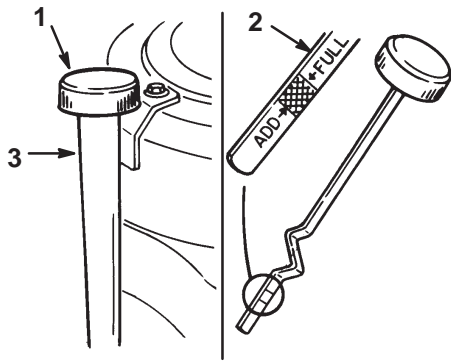

1868

Figure 18

1. Oil dipstick
2. Metal end
3. Filler tube

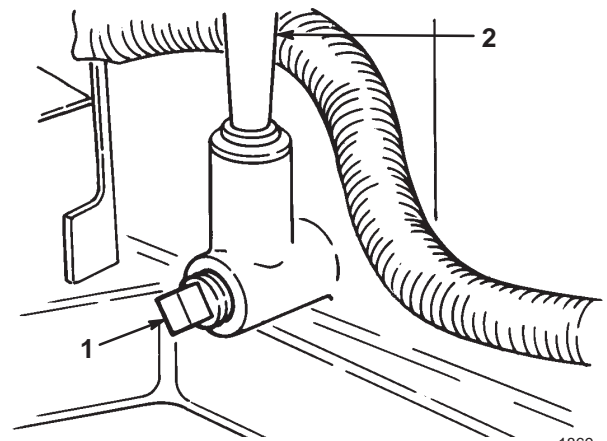

1869

Figure 19

1. Oil drain plug
2. Oil dipstick/fill tube

Changing and Draining the Oil

1. Start the engine and let it run five minutes. This warms the oil so that it drains better.
2. Park the machine so that the drain side is slightly lower than the opposite side to ensure that the oil drains completely. Then disengage the PTO, set the parking brake, stop the engine, and remove the ignition key.
3. Open the hood.
4. Place a pan below the oil dipstick/fill tube and remove the drain plug (Fig. 19).
5. When the oil has drained completely, install the drain plug.

Note: Dispose of the used oil at a certified recycling center.

6. Change the oil filter, if necessary; refer to Changing the Oil Filter, page 21.
7. Slowly pour approximately 80% of the specified amount of oil into the filler tube (Fig. 18). Check the oil level; refer to Checking the Oil Level, page 20. Slowly add additional oil to bring the level to the Full mark on the dipstick.

Changing the Oil Filter

Replace the oil filter every 100 hours or yearly, whichever occurs first.

1. Drain the oil from the engine; refer to Changing and Draining the Oil, page 21.
2. Remove the old filter and wipe the filter adapter (Fig. 20) gasket surface.
3. Apply a thin coat of new oil to the rubber gasket on the replacement filter (Fig. 20).

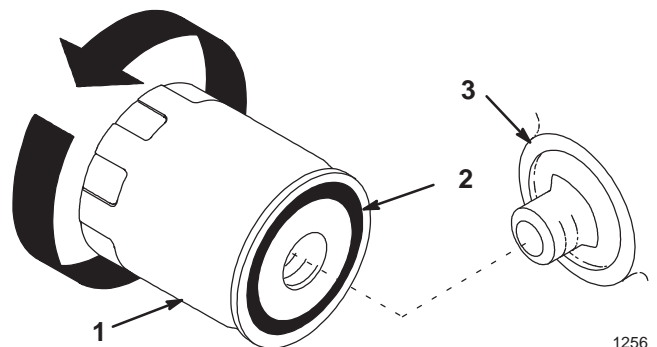

1256

Figure 20

1. Oil filter
2. Gasket
3. Adapter

4. Install the replacement oil filter to the filter adapter. Turn the oil filter clockwise until the rubber gasket contacts the filter adapter, then tighten the filter an additional 1/2 to 3/4 turn (Fig. 20).
5. Fill the crankcase with the proper type of new oil; refer to Checking the Oil Level, page 20.

Brake

The brake is on the right side of the rear axle, inside the rear tire (Fig. 21). If the tractor requires more than one meter to stop at high speed in the highest gear, then the brake must be adjusted.

Checking the Brake

1. Park the machine on a level surface, disengage the PTO, set the parking brake, stop the engine, and remove the ignition key.
2. Pull the drive control out to the Push position (Fig. 14).
3. If the rear wheels lock and skid when you push the tractor forward, no adjustment is required. An adjustment is required if the wheels turn and do not lock; refer to Adjusting the Brake, page 22.

Adjusting the Brake

1. Check the brake before you adjust it; refer to Checking the Brake, page 22.
2. Ensure the drive control is in the Operate position (Fig. 14) and the parking brake is on.
3. To adjust the brake, turn the brake adjusting nut clockwise until you can not push the tractor (Fig. 21).
4. Release the parking brake and ensure that the rear wheels rotate freely when you push the tractor. If they do not, turn the brake adjusting nut counterclockwise just until you can push the tractor.
5. Check the brake operation again; refer to Checking the Brake, page 22.

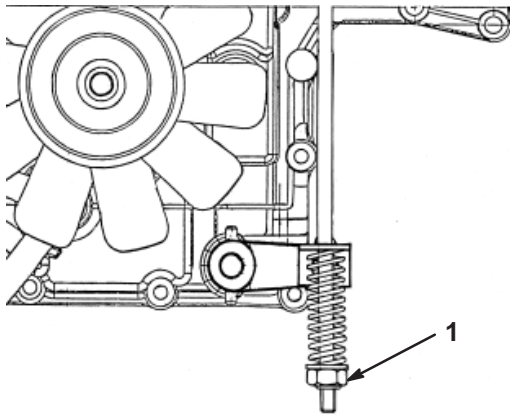
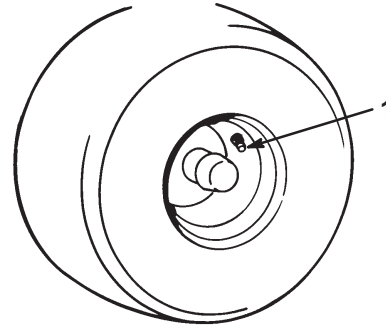

Figure 21

1. Brake adjusting nut

Tire Pressure

Maintain the air pressure in the front tires at 120 kPa and in the rear tires at 100 kPa. Check the pressure at the valve stem after every 25 operating hours or yearly, whichever occurs first (Fig. 22). Check the tires when they are cold to get the most accurate pressure reading.



1872

Figure 22

1. Valve stem

Greasing and Lubrication

Service Interval/Specification

Grease the machine after every 25 operating hours or once a year, whichever occurs first. Grease more frequently when operating conditions are extremely dusty or sandy.

Grease Type: General-purpose grease.

How to Grease

1. Disengage the PTO, set the parking brake, stop the engine, and remove the ignition key.
2. Clean the grease fittings with a rag. Make sure to scrape any paint off of the front of the fitting(s).
3. Connect a grease gun to the fitting. Pump grease into the fittings.
4. Wipe up any excess grease.

Where to Add Grease

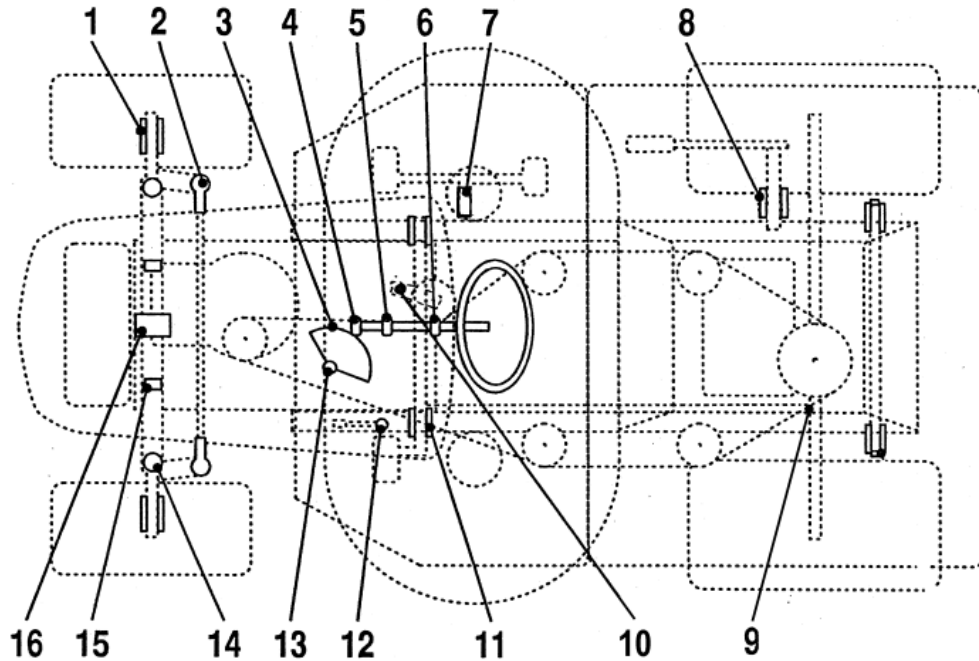

Figure 23

Lubrication List

Item	Name	Quantity	Interval (hours)	Lubricant
1	Front wheel—grease fitting	2	25	Grease
2	Steering ball joints	4	50	Oil
3	Steering sector gear	1	50	Grease
4	Steering pinion gear	1	25	Grease
5	Steering shaft bearing	1	50	Oil
6	Steering shaft bearing	1	50	Oil
7	Motion lever—grease fitting	1	50	Grease
8	Shaft hub for lifting the mower deck	1	50	Oil
9	Motion link ball joints	4	50	Oil
10	Brake pedal hub	2	50	Oil
11	Parking brake ring	1	50	Oil
12	Steering bearing	1	25	Grease
13	Left and Right Spindle—grease fitting	2	25	Grease
14	Mower deck hinged pin	6	When removed	Grease
15	Front axle pivot pin	2	When removed	Grease
16	Front axle pivot pin	2	25	Grease

Fuse

Service Interval/Specification

The electrical system is protected by fuses. They are located beneath the hood, near the fuel tank (Fig. 24). No maintenance is required, however, if a fuse blows check the circuit wiring for a short.

To replace a fuse, pull up to remove it from the socket. Push down to insert it.

- Main, battery—15 amp
- Headlights—10 amp
- Interlock, electric clutch—10 amp
- Full bag buzzer—5 amp

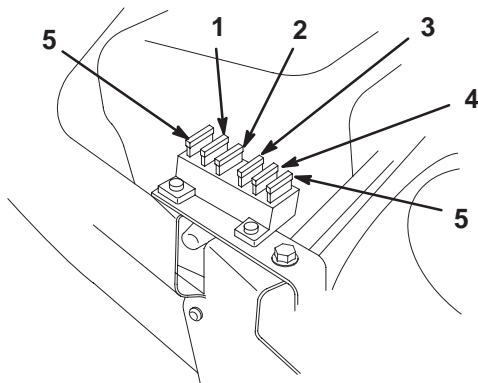

Figure 24

- | | |
|-------------------------------|--------------------|
| 1. Main, battery | 4. Full bag buzzer |
| 2. Headlights | 5. Extra fuse |
| 3. Interlock, electric clutch | |

m-4986

Headlights

Specification: Bulb # 1156, automotive type

Removing the Bulb

1. Disengage the PTO, set the parking brake, stop the engine, and remove the ignition key.
2. Open the hood. Pull the wire connectors off of both of the bulb holder terminals.
3. Rotate the bulb holder 1/4 turn counterclockwise and remove it from the reflector (Fig. 25).
4. Push and rotate the bulb counterclockwise until it stops (approximately 1/4 turn) and remove the bulb from the bulb holder (Fig. 26).

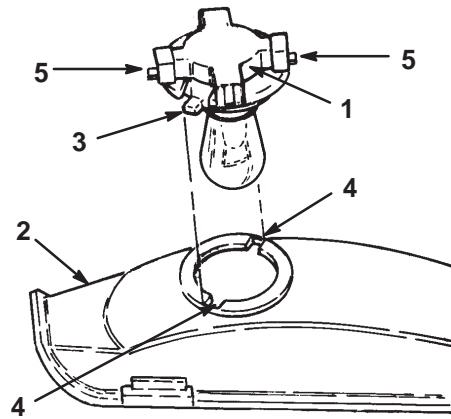

1874

Figure 25

- | | |
|----------------|--------------|
| 1. Bulb holder | 4. Slots |
| 2. Reflector | 5. Terminals |
| 3. Tabs | |

Installing the Bulb

1. The bulb has metal pins on the side of its base. Align the pins with the slots in the bulb holder and insert the base into the holder (Fig. 26). Push and rotate the bulb clockwise until it stops.

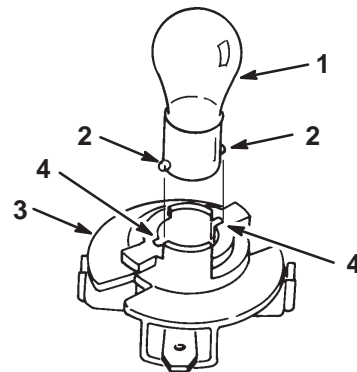

1875

Figure 26

- | | |
|---------------|----------------|
| 1. Bulb | 3. Bulb holder |
| 2. Metal pins | 4. Slots |
2. The bulb holder has two tabs (Fig. 25). Align the tabs with the slots in the reflector, insert the bulb holder into the reflector, and rotate it 1/4 turn clockwise until it stops.
 3. Push the wire connectors onto the terminals on the bulb holder.

Battery

Service Interval/Specification

Check the electrolyte level in the battery before each use. Always keep the battery clean and fully charged. Use a paper towel to clean the battery and battery box. If the battery terminals are corroded, clean them with a solution of four parts water and one part baking soda. Apply a light coating of grease to the battery terminals to prevent corrosion.

Voltage: 12 v, 190 Cold Cranking Amps

Removing the Battery

1. Disengage the PTO, set the parking brake, stop the engine, and remove the ignition key.
2. Tip the seat forward to see the battery.
3. Lift the rubber cover up off of the negative (black) cable. Disconnect the negative (black) ground cable from the battery post (Fig. 27).

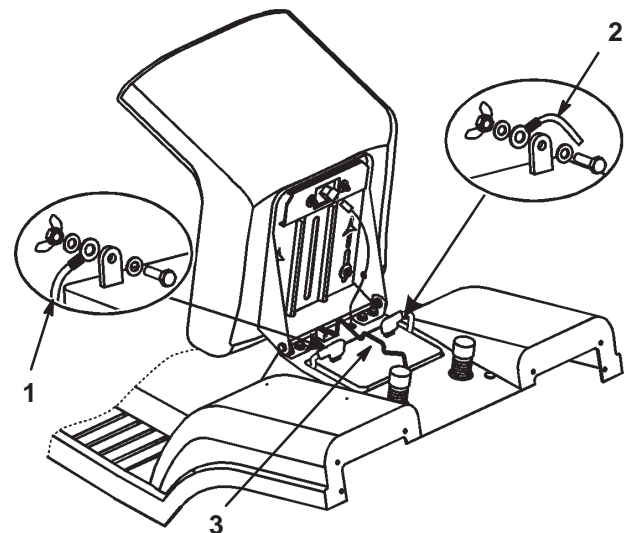

Figure 27

1. Negative cable (black)
2. Positive cable (red)
3. Hold-down rod

! **Warning** !

Battery terminals or metal tools could short against metal tractor components causing sparks. Sparks can cause the battery gasses to explode, resulting in personal injury.

- When removing or installing the battery, do not allow the battery terminals to touch any metal parts of the tractor.
- Do not allow metal tools to short between the battery terminals and metal parts of the tractor.

! **Warning** !

Incorrect battery cable routing could damage the tractor and cables causing sparks. Sparks can cause the battery gasses to explode, resulting in personal injury.

- Always *disconnect* the negative (black) battery cable before disconnecting the positive (red) cable.
- Always *connect* the positive (red) battery cable before connecting the negative (black) cable.

4. Lift the rubber cover up off of the positive (red) cable. Disconnect the positive (red) cable from the battery post (Fig. 27).
5. Remove the battery hold down rod (Fig. 27).
6. Remove the battery from the chassis.

Installing the Battery

1. Place the battery into the chassis with the battery posts toward the front of the tractor (Fig. 27).
2. Secure the battery in the chassis with the hold down rod (Fig. 27).
3. Using the bolt and wing nut, connect the positive (red) cable to the positive (+) battery post (Fig. 27). Slide the rubber cover over the battery post.
4. Using the bolt and wing nut, connect the negative (black) cable to the negative (-) battery post (Fig. 27). Slide the rubber cover over the battery post.

Checking the Electrolyte Level

1. Tip the seat forward to see the battery.
2. Remove the filler caps. If the electrolyte is not up to the lower part of the tube (Fig. 28), add the required amount of distilled water; refer to Adding Water to the Battery, page 26.

! **Danger** !

Battery electrolyte contains sulfuric acid which is a deadly poison and causes severe burns.

- Do not drink electrolyte and avoid contact with skin, eyes or clothing. Wear safety glasses to shield your eyes and rubber gloves to protect your hands.
- Fill the battery where clean water is always available for flushing the skin.

Adding Water to the Battery

The best time to add distilled water to the battery is just before you operate the machine. This lets the water mix thoroughly with the electrolyte solution.

1. Clean the top of the battery with a paper towel.
2. Remove the filler caps (Fig. 28).

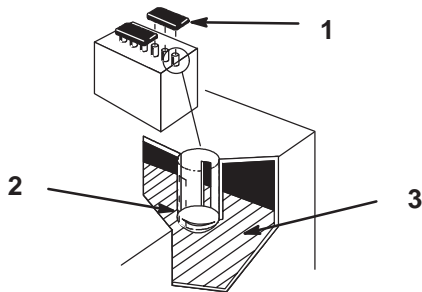

Figure 28

1. Filler caps
2. Lower part of tube
3. Plates

3. Slowly pour distilled water into each battery cell until the level is up to the lower part of the tube (Fig. 28).

Important Do not overfill the battery. Electrolyte (sulfuric acid) can cause severe corrosion and damage to the chassis.

4. Replace the filler caps.

Charging the Battery

Important Always keep the battery fully charged (1.260 specific gravity). This is especially important to prevent battery damage when the temperature is below 32°F (0°C).

1. Remove the battery from the chassis; refer to Removing the Battery, page 25.
2. Check the electrolyte level; refer to Checking the Electrolyte Level, page 25.
3. Remove the filler caps from the battery and connect a 2 amp battery charger to the battery posts. Charge the battery at a rate of 2 amperes or less for 4 hours (12 volts). Do not overcharge the battery. Install the filler caps after the battery is fully charged.



Warning



Charging the battery produces gasses that can explode.

Never smoke near the battery and keep sparks and flames away from battery.

4. Install the battery in the chassis; refer to Installing the Battery, page 25.

Spark Plug

Service Interval/Specification

Install a new spark plug(s) after every 100 operating hours. Make sure the air gap between the center and side electrodes is correct before installing the spark plug(s). Use a spark plug wrench for removing and installing the spark plug(s) and a gapping tool/feeler gauge to check and adjust the air gap.

Type: Champion RC12YC (or equivalent)

Air Gap: .76 mm (0.030 in.)

Removing the Spark Plug(s)

1. Disengage the PTO, set the parking brake, stop the engine, and remove the ignition key.
2. Open the hood.
3. Pull the wire(s) off of the spark plug(s) (Fig. 29). Clean around the spark plug(s) to prevent dirt from falling into the engine and potentially causing damage.
4. Remove the spark plug(s) and metal washer.

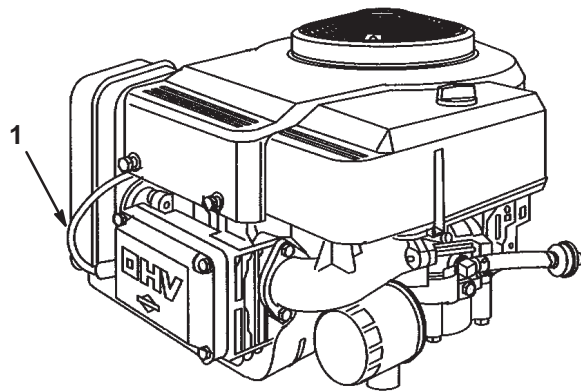

Figure 29

1. Spark plug wire

Checking the Spark Plug(s)

1. Look at the center of the spark plug(s) (Fig. 30). If you see light brown or gray on the insulator, the engine is operating properly. A black coating on the insulator usually means the air cleaner is dirty.

Important Never clean the spark plug(s). Always replace the spark plug(s) when it has a black coating, worn electrodes, an oily film, or cracks.

2. Check the gap between the center and side electrodes (Fig. 30). Bend the side electrode (Fig. 30) if the gap is not correct.

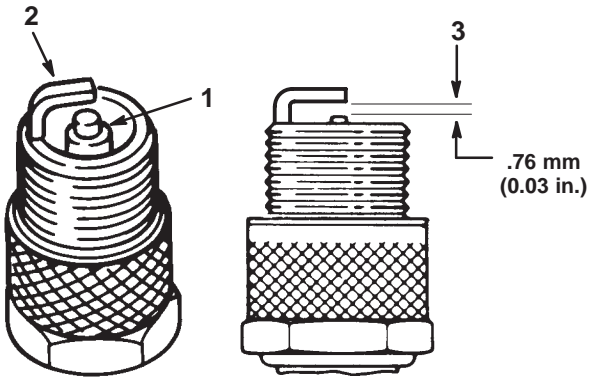

Figure 30

1. Center electrode insulator
2. Side electrode
3. Air gap (not to scale)

Installing the Spark Plug(s)

1. Install the spark plug(s) and metal washer. Make sure the air gap is set correctly.
2. Tighten the spark plug(s) to 15 ft.-lb. (20.4 N·m).
3. Push the wire(s) onto the spark plug(s) (Fig. 29).
4. Close the hood.

Draining the Fuel Tank

The fuel tank must be drained when the machine will not be used for more than 30 days.

⚠
Danger
⚠

In certain conditions, gasoline is extremely flammable and highly explosive. A fire or explosion from gasoline can burn you and others and can damage property.

- **Drain gasoline from the fuel tank when the engine is cold. Do this outdoors in an open area. Wipe up any gasoline that spills.**
- **Never smoke when draining gasoline, and stay away from an open flame or where a spark may ignite the gasoline fumes.**

1. Park the machine so that the left front side is slightly lower than the right side to ensure that the fuel drains completely. Disengage the PTO, set the parking brake, stop the engine, and remove the ignition key.
2. Open the hood.
3. Squeeze the ends of the hose clamp together and slide it up the fuel line toward the fuel tank (Fig. 31).
4. Pull the fuel line off of the filter (Fig. 31) and allow gasoline to drain into a gas can or drain pan.

Note: Now is the best time to install a new fuel filter because the fuel tank is empty.

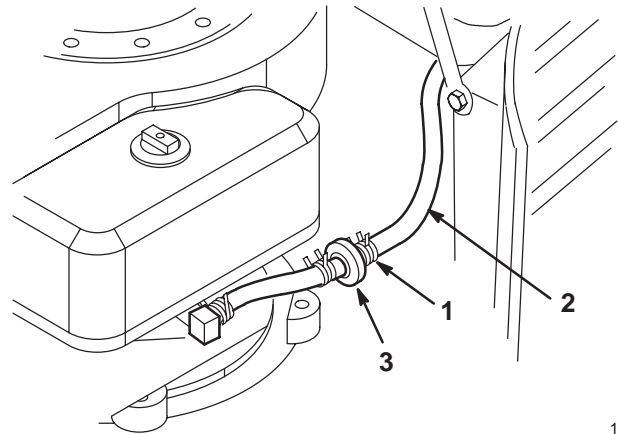

Figure 31

1. Hose clamp
2. Fuel line
3. Filter

5. Install the fuel line onto the filter. Slide the hose clamp close to the filter to secure the fuel line and filter.

Fuel Filter

Service Interval/Specification

Replace the fuel filter after every 100 operating hours or yearly, whichever occurs first.

Replacing the Fuel Filter

The best time to replace the fuel filter (Fig. 31) is when the fuel tank is empty. Never install a dirty filter if it is removed from the fuel line.

1. Disengage the PTO, set the parking brake, stop the engine, and remove the ignition key.
2. Turn the fuel shut-off valve off (Fig. 32).

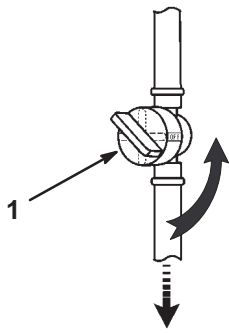

Figure 32

1. Fuel shut-off valve

3. Open the hood.
4. Squeeze the ends of the hose clamps together and slide them away from the filter (Fig. 31).
5. Remove the filter from the fuel lines.
6. Install a new filter and move the hose clamps close to the filter.
7. Close the hood.

Air Cleaner

Service Interval/Specification

Foam Element: Clean and oil after every 25 operating hours, or yearly, whichever occurs first.

Paper Element: Replace after every 100 operating hours or yearly, whichever occurs first.

Note: Service the air cleaner more frequently (every few hours) if operating conditions are extremely dusty or sandy.

Removing the Foam and Paper Elements

1. Disengage the PTO, set the parking brake, stop the engine, and remove the ignition key.
2. Open the hood.
3. Clean around the air cleaner to prevent dirt from getting into the engine and causing damage. Unscrew the knob and remove the air cleaner cover (Fig. 33).

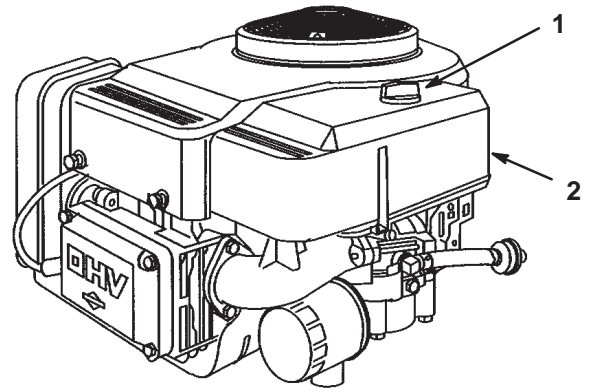
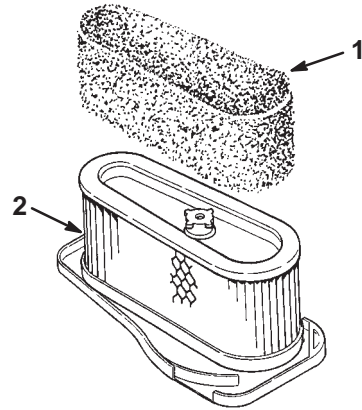

Figure 33

1. Knob
2. Air cleaner cover

4. Carefully slide the foam element off the paper element (Fig. 34).



1864

Figure 34

1. Foam element
2. Paper element

5. Unscrew the rubber nut and remove the paper element (Fig. 35).

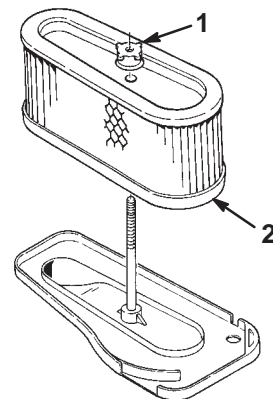

1865

Figure 35

1. Rubber nut
2. Paper element

Cleaning the Foam and Paper Elements

1. Foam Element

- Wash the foam element in liquid soap and warm water. When the element is clean, rinse it thoroughly.
- Dry the element by squeezing it in a clean cloth.
- Saturate the element in engine oil (Fig. 36). Squeeze the element in a clean, absorbent cloth to remove excess oil.

Important Replace the foam element if it is torn or worn.

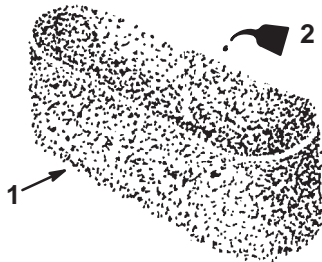

1866

Figure 36

1. Foam element 2. Oil

2. Paper Element

- Lightly tap the element on a flat surface to remove dust and dirt (Fig. 37).
- Inspect the element for tears, an oily film, and damage to the rubber seal.

Important Never clean the paper element with pressurized air or liquids, such as solvent, gas, or kerosene. Replace the paper element if it is damaged or cannot be cleaned thoroughly.

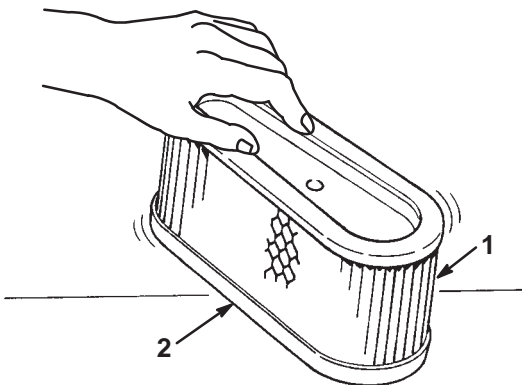

1867

Figure 37

1. Paper element 2. Rubber seal

Installing the Foam and Paper Elements

Important To prevent engine damage, always operate the engine with the complete foam and paper air cleaner assembly installed.

- Carefully slide the foam element onto the paper air cleaner element (Fig. 34).
- Slide the air cleaner assembly onto the long rod. Screw the rubber nut finger-tight against the air cleaner (Fig. 35).

Note: Make sure the rubber seal is flat against the air cleaner base.

- Install the air cleaner cover and knob (Fig. 33). Tighten the knob snugly.
- Close the hood.

Cutting Blade

To ensure a superior quality of cut, keep the blades sharp. For convenient sharpening and replacement, you may want to have extra blades.



Danger



A worn or damaged blade can break, and a piece of the blade could be thrown into the operator's or bystander's area, resulting in serious personal injury or death.

- Inspect the blade periodically for wear or damage.
- Replace a worn or damaged blade.

Inspecting the Blades

- Remove the mower; refer to Removing the Mower, page 30.
- Inspect the cutting edges (Fig. 38). If the edges are not sharp or have nicks, remove the blades and sharpen them; refer to Sharpening the Blade(s), page 30.
- Inspect the blades, especially the bent edges (Fig. 38). If you notice any wear or damage in this area, immediately install a new blade.
- If the shear pins are broken, replace them immediately (Fig. 38).

Important If the shear pins are broken, the mower belt may be damaged. Inspect the belt; refer to Adjusting the Blade Drive Belt, page 31.

Removing the Blade

1. Remove the mower; refer to Removing the Mower, page 30.
2. Carefully tip the mower over.
3. Remove the bolt, washer, and blade (Fig. 38). A block of wood may be wedged between the blade and the mower to lock the blade when you are removing the bolt.

Note: The right blade has a left-hand threaded bolt.

4. Inspect all parts. If a defect or damage is noticed, install new parts.

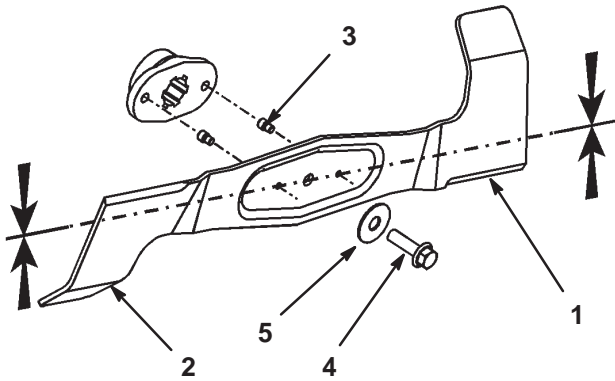

Figure 38

- | | |
|-----------------|-----------|
| 1. Cutting edge | 4. Bolt |
| 2. Bent edge | 5. Washer |
| 3. Shear pins | |

Sharpening the Blade(s)

1. Use a file to sharpen the cutting edge at both ends of the blade (Fig. 39). Maintain the original angle. The blade retains its balance if the same amount of material is removed from both cutting edges.

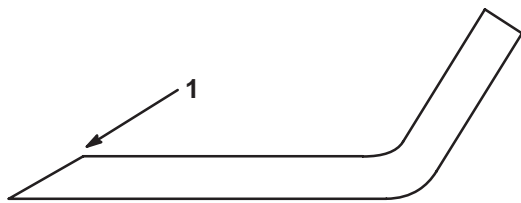

Figure 39

1. Sharpen at original angle
-
2. Check the balance of the blade by putting it on a blade balancer (Fig. 40). If the blade stays in a horizontal position, the blade is balanced and can be used. If the blade is not balanced, file some metal off of the back side of the blade. Repeat this procedure until the blade is balanced.

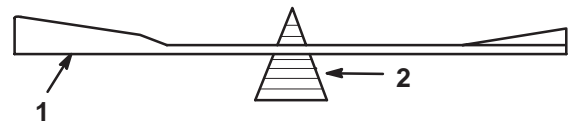

Figure 40

- | | |
|----------|-------------|
| 1. Blade | 2. Balancer |
|----------|-------------|

Installing the Blade(s)

1. Install the blade, washer, and blade bolt (Fig. 38).

Important The bent edges of the blade must be pointing toward the top of the mower to ensure proper cutting.

2. Position the blades 90 degrees to each other (Fig. 41).
3. Tighten the blade bolt to 50 N·m.

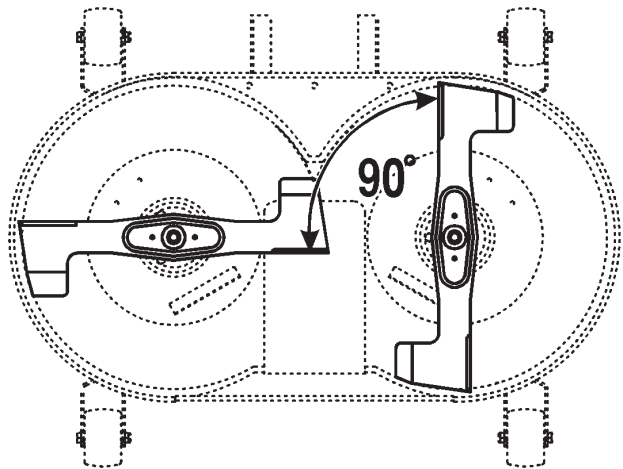

Figure 41

Removing the Mower

1. Park the machine on a level surface, disengage the PTO, set the parking brake, stop the engine, and remove the ignition key. Pull the wire off of the spark plug(s).
2. Move the height-of-cut lever to the lowest position.
3. Pull the idler arm assembly in and remove the V-belt from the pulley (Fig. 42).
4. Disconnect the spring from the engagement lever (Fig. 42).
5. Release the mower from the tunnel by lifting the tunnel off of the two welded pins and pulling the tunnel rearward approximately 10 cm. Secure the tunnel to prevent it from falling back down.

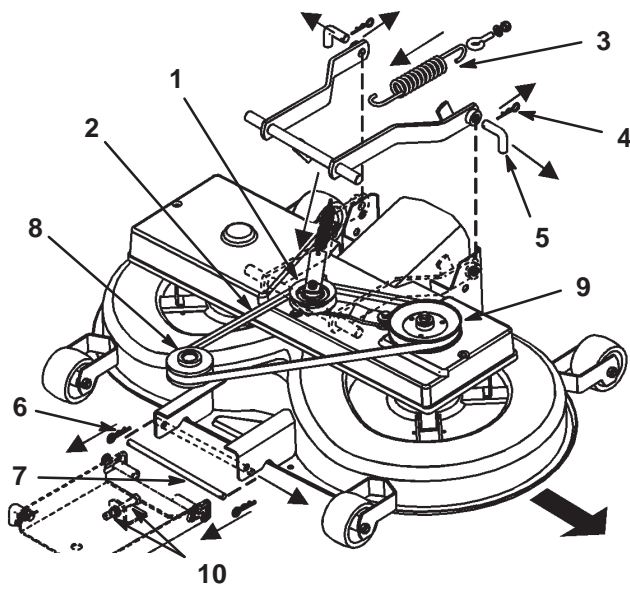

Figure 42

- | | |
|--|-------------------------------|
| 1. Idler pulley and idler arm assembly | 6. Front hairpin clips |
| 2. V-belt | 7. Front pin |
| 3. Engagement spring | 8. Engine pulley |
| 4. Rear hairpin clips | 9. V-belt pulley |
| 5. Rear pins | 10. Front suspension M12 nuts |

6. Remove the hairpin clips from the two rear pins and remove the pins (Fig. 42). A pliers may be needed to pull the second pin out.
7. Remove the hairpin clip from the front pin and remove the pin (Fig. 42).
8. Remove the V-belt from the engine pulley (Fig. 42).
9. Slide the mower out from beneath the tractor.

Installing the Mower

Reverse the procedure for Removing the Mower, page 30.

Adjusting the Blade Drive Belt

Adjust the blade drive belt after the first 20 operating hours and every 50 operating hours thereafter.

1. Remove the mower; refer to Removing the Mower, page 30.

Note: It is not possible to adjust the blade drive belt correctly without removing the mower.

2. Remove the V-belt pulley and idler arm assembly (Fig. 42).
3. Remove the belt cover.

4. Loosen the two hex nuts on the idler pulley (Fig. 43).
5. Adjust the M10 nut until the belt flexes 5 mm with 3 kp of force (Fig. 43).

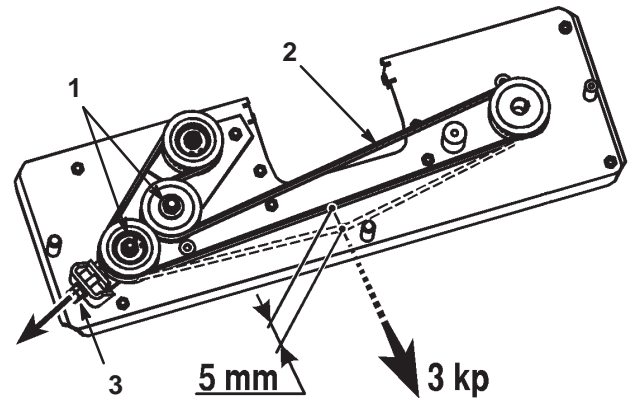

Figure 43

Top View

- | | |
|---------------|------------|
| 1. Hex nuts | 3. M10 nut |
| 2. Mower belt | |

6. Tighten the two hex nuts on the idler pulley.
7. Reinstall the mower; refer to Installing the Mower, page 31.

Adjusting the Height Adjustment Cable Rod Assembly

Check the front-to-rear blade slope every 100 hours, yearly, or any time you install the mower. Before you check the slope, set the air pressure in the front and rear tires to the recommended inflation; refer to Tire Pressure, page 22. If the front of the mower is not within a range of 3.5–10.5 mm (1/8–3/8 in.) lower than the rear of the mower, adjust the blade slope using the following instructions:

1. Park the machine on a level surface, disengage the PTO, set the parking brake, stop the engine, and remove the ignition key. Pull the wire off the spark plug(s).
2. Move the lower pin of the front adjustment suspension into the bottom position of the slotted holes by adjusting the 2 nuts (M12) on the front suspension (Fig. 42).
3. Move the height-of-cut lever to position 1. The front mower gauge wheels must rest on the ground.
4. Adjust the M8 locknut at the end of the height adjustment rod assembly until the rod is slightly taut (Fig. 44).

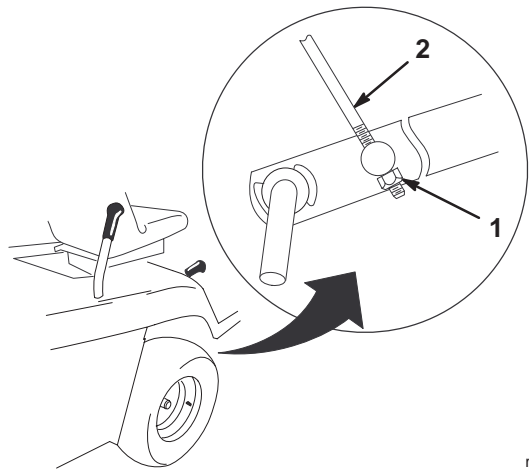

m-4935

Figure 44

1. M8 locknut
2. Height adjustment rod

Grass Collector

Removing the Grass Collector

1. Using two hands, tip the grass collector forward (Fig. 45).
2. Carefully slide the assembly rearward off of the support brackets.

Installing the Grass Collector

1. Lift the grass collector assembly with two hands.
2. Tip the collector forward approximately 40 degrees and slide it onto the two support brackets at the rear of the tractor (Fig. 45). Ensure that the arrow on the top of the grass collector aligns with the arrow on the tractor.

Note: The cutting unit will not function when the grass collector is not in place.

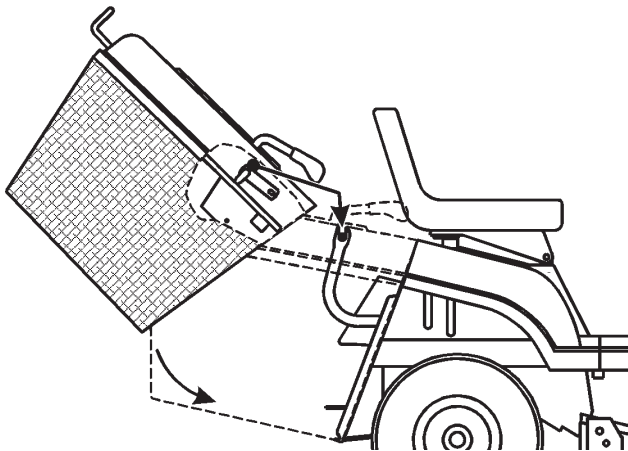

Figure 45

Cleaning the Grass Collector and Tunnel

If the holes on the grass collector bag become clogged with dirt and grass or if the full-bag sensor is dirty, the collector must be cleaned.

1. Disengage the PTO, set the parking brake, stop the engine, and remove the ignition key.
2. Remove the grass collector; refer to Removing the Grass Collector, page 32.
3. Clean the collector bag with pressurized water.
4. Wipe the area around the full-bag sensor.
5. Clean the inside of the tunnel all the way to the cutting unit.
6. Install the grass collector; refer to Installing the Grass Collector, page 32.

Note: Allow the bag to dry thoroughly before reinstalling.

Cleaning and Storage

1. Disengage the PTO, set the parking brake, stop the engine, and remove the key.
2. Remove the grass collector and clean it; refer to Grass Collector, page 32.
3. Remove grass clippings, dirt, and grime from the external parts of the entire machine, especially the engine. Clean dirt and chaff from the outside of the engine cylinder head fins and blower housing.

Important You can wash the machine with mild detergent and water. Do not use pressurized liquids to wash the machine. Pressurized liquids may damage the electrical system or wash away necessary grease at friction points. Avoid excessive use of water, especially near the control panel, lights, engine, and the battery.

4. Check the brake; refer to Brake, page 22.
5. Service the air cleaner; refer to Air Cleaner, page 28.
6. Grease the chassis; refer to Greasing and Lubrication, page 22.
7. Change the crankcase oil and filter; refer to Engine Oil, page 20.
8. Check the tire pressure; refer to Tire Pressure, page 22.
9. Prepare the machine for storage when non-use occurs over 30 days. Prepare machine for storage as follows.
 - A. Add a petroleum based stabilizer/conditioner to fuel in the tank. Follow the mixing instructions from stabilizer manufacturer. (1 oz. per gallon). **Do not use an alcohol based stabilizer (ethanol or methanol).**

Note: A fuel stabilizer/conditioner is most effective when mixed with fresh gasoline and used at all times.

- B. Run engine to distribute conditioned fuel through the fuel system (5 minutes).
- C. Stop the engine, allow it to cool, and drain the fuel tank; refer to Draining the Fuel Tank, page 27.
- D. Restart engine and run it until it stops.
- E. Choke or prime the engine.
- F. Start and run engine until it will not start again. Use the primer, if equipped on the machine, several times to ensure that no fuel remains in the primer system.
- G. Dispose of fuel properly. Recycle as per local codes.
- H. Close the fuel shut-off valve.

Important Do not store stabilizer/conditioned gasoline over 90 days.

- 10. Remove the spark plug(s) and check its condition; refer to Spark Plug, page 26. With the spark plug(s) removed from the engine, pour two tablespoons of engine oil into the spark plug hole. Use the electric starter to crank the

engine and distribute the oil inside the cylinder. Install the spark plug(s); refer to Spark Plug, page 26. Do not install the wire on the spark plug(s).

- 11. Disconnect the negative battery cable. Clean the battery and battery terminals. Check the electrolyte level and charge it fully; refer to Battery, page 25. Leave the negative battery cable disconnected from the battery during storage.

Important The battery must be fully charged to prevent it from freezing and being damaged at temperatures below 32°F (0°C). A fully charged battery can be stored one winter season without recharging.

- 12. Check and tighten all bolts, nuts, and screws. Repair or replace any part that is worn or damaged.
- 13. Paint all scratched or bare metal surfaces. Paint is available from your Authorized Service Dealer.
- 14. Store the machine in a clean, dry garage or storage area. Remove the ignition and KeyChoice keys from the mower and keep them in a memorable place. Cover the machine to protect it and keep it clean.

Troubleshooting

Problem	Possible Causes	Corrective Action
The starter does not crank.	<ul style="list-style-type: none"> 1. The blade control (PTO) is engaged. 2. The parking brake is not on. 3. The battery is dead. 4. The electrical connections are corroded or loose. 5. A fuse is blown. 6. A relay or switch is damaged. 	<ul style="list-style-type: none"> 1. Move the PTO to Disengaged. 2. Set the parking brake. 3. Charge the battery. 4. Check the electrical connections for good contact. 5. Replace the fuse. 6. Contact an Authorized Service Dealer.
The engine overheats.	<ul style="list-style-type: none"> 1. The engine load is excessive. 2. The oil level in the crankcase is low. 3. The cooling fins and air passages under the engine blower housing are plugged. 	<ul style="list-style-type: none"> 1. Reduce your ground speed. 2. Add oil to the crankcase. 3. Remove the obstruction from the cooling fins and air passages.
The machine does not drive.	<ul style="list-style-type: none"> 1. The drive control is in the Push position. 2. The traction belt is worn, loose, or broken. 3. The traction belt is off of the pulley. 	<ul style="list-style-type: none"> 1. Move the drive control to the Operate position. 2. Contact an Authorized Service Dealer. 3. Contact an Authorized Service Dealer.

Problem	Possible Causes	Corrective Action
The engine will not start, starts hard, or fails to keep running.	<ol style="list-style-type: none"> 1. The operator is not seated. 2. The fuel tank is empty. 3. The air cleaner is dirty. 4. The spark plug wire is loose or disconnected. 5. A spark plug is pitted, fouled, or the gap is incorrect. 6. The choke is not closing. 7. There is dirt in the fuel filter. 8. The idle speed is too low or the mixture is incorrect. 9. Dirt, water, or stale fuel is in the fuel system. 10. The fuel shut-off valve is closed. 	<ol style="list-style-type: none"> 1. Sit on the seat. 2. Fill the fuel tank with gasoline. 3. Clean or replace the air cleaner element. 4. Install the wire on the spark plug. 5. Install a new, correctly-gapped spark plug. 6. Adjust the throttle cable. 7. Replace the fuel filter. 8. Adjust the carburetor idle speed and idle mixture. 9. Contact an Authorized Service Dealer. 10. Open the fuel shut-off valve.
The engine loses power.	<ol style="list-style-type: none"> 1. The engine load is excessive. 2. The air cleaner is dirty. 3. The oil level in the crankcase is low. 4. The cooling fins and air passages under the engine blower housing are plugged. 5. The spark plug is pitted, fouled, or the gap is incorrect. 6. The vent hole in the fuel cap is plugged. 7. There is dirt in the fuel filter. 8. Dirt, water, or stale fuel is in the fuel system. 	<ol style="list-style-type: none"> 1. Reduce your ground speed. 2. Clean the air cleaner element. 3. Add oil to the crankcase. 4. Remove the obstruction from the cooling fins and air passages. 5. Install a new, correctly-gapped spark plug. 6. Clean or replace the fuel cap. 7. Replace the fuel filter. 8. Contact an Authorized Service Dealer.
There is abnormal vibration.	<ol style="list-style-type: none"> 1. The cutting blade(s) is bent or unbalanced. 2. The blade mounting screws are loose. 3. The engine mounting bolts are loose. 4. There is a loose engine pulley, idler pulley, or blade pulley. 5. The engine pulley is damaged. 6. The blade drive belt is damaged. 	<ol style="list-style-type: none"> 1. Install a new cutting blade(s). 2. Tighten the blade mounting screws. 3. Tighten the engine mounting bolts. 4. Tighten the appropriate pulley. 5. Contact an Authorized Service Dealer. 6. Install a new blade drive belt.

Problem	Possible Causes	Corrective Action
The blade(s) does not rotate.	<ol style="list-style-type: none"> 1. The blade drive belt is worn, loose, or broken. 2. The blade drive belt is off of the pulley. 3. The grass collector is not in place. 	<ol style="list-style-type: none"> 1. Install a new blade drive belt. 2. Install the blade drive belt and adjust it for the correct tension. 3. Install the grass collector.
The cutting height is uneven.	<ol style="list-style-type: none"> 1. The tire pressure is incorrect. 2. The mower is not level. 3. The underside of the mower is dirty. 4. The blade mounting screws are loose. 5. The blade drive belt tension is incorrect. 	<ol style="list-style-type: none"> 1. Set the tire pressure. 2. Adjust the height adjustment cable rod assembly. 3. Clean the underside of the mower. 4. Tighten the blade mounting screws. 5. Adjust the blade drive belt.

