



Count on it.

Operator's Manual

Flex-Force Power System™ 60V MAX String Trimmer

Model No. 51832—Serial No. 321000001 and Up

Model No. 51832T—Serial No. 321000001 and Up

Model No. 51836—Serial No. 321000001 and Up

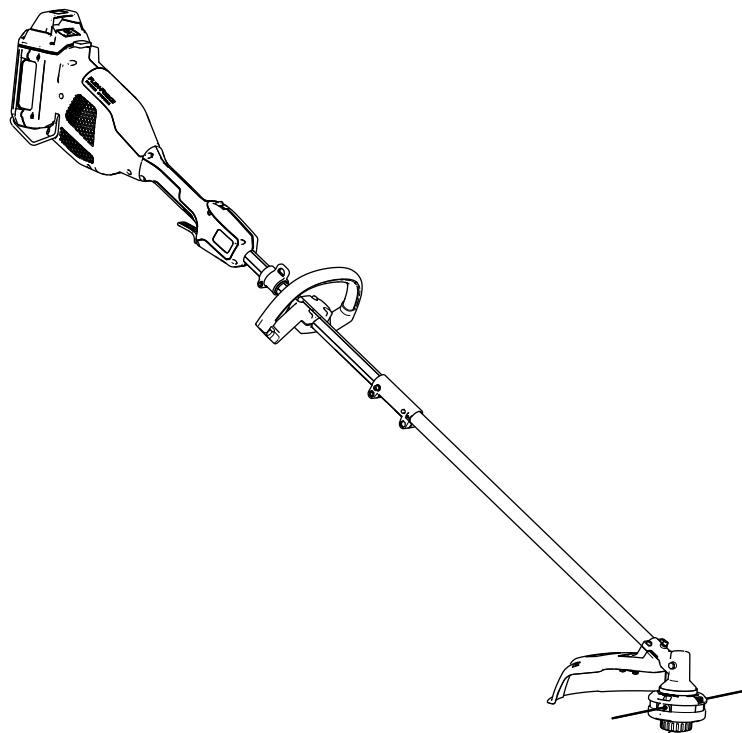



For assistance, please see www.Toro.com/support for instructional videos or contact 1-888-384-9939 before returning this product.

⚠ WARNING

**CALIFORNIA
Proposition 65 Warning**

The power cord on this product contains lead, a chemical known to the State of California to cause birth defects or other reproductive harm. Wash hands after handling.

Use of this product may cause exposure to chemicals known to the State of California to cause cancer, birth defects, or other reproductive harm.

Whenever you need service, genuine the manufacturer parts, or additional information, contact an Authorized Service Dealer or the manufacturer Customer Service and have the model and serial numbers of your product ready. Figure 1 identifies the location of the model and serial numbers on the product. Write the numbers in the space provided.

Important: With your mobile device, you can scan the QR code on the serial number decal (if equipped) to access warranty, parts, and other product information.

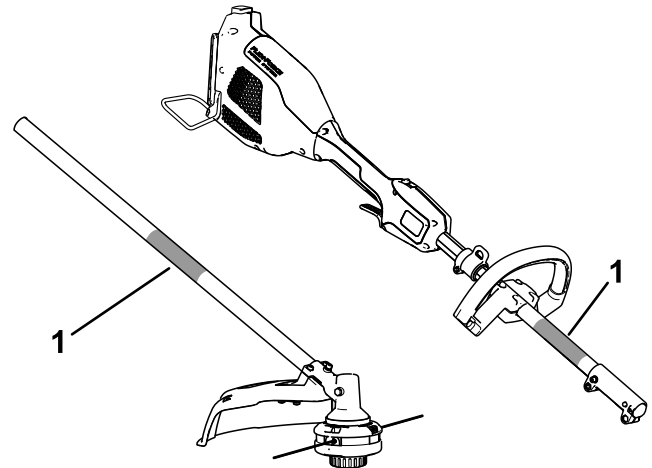

g372937

Figure 1

1. Model and serial number locations

Model No. _____

Serial No. _____

This manual identifies potential hazards and has safety messages identified by the safety-alert symbol (Figure 2), which signals a hazard that may cause serious injury or death if you do not follow the recommended precautions.



sa-black

Figure 2

Safety-alert symbol

This manual uses 2 words to highlight information. **Important** calls attention to special mechanical information and **Note** emphasizes general information worthy of special attention.

Introduction

This trimmer is intended to be used by residential homeowners to trim grass as needed outdoors. It is designed to use Toro Flex-Force lithium-ion battery pack Models 88620 (provided with Model 51832), 88625 (provided with Model 51836), 88640, 88650, 88660, or 88675. These battery packs are designed to be charged only by battery charger Models 88602 (provided with 51836), 88605, or 88610 (provided with 51832). Using this product for purposes other than its intended use could prove dangerous to you and bystanders.

Read this information carefully to learn how to operate and maintain your product properly and to avoid injury and product damage. You are responsible for operating the product properly and safely.

Visit www.Toro.com for product safety and operation training materials, accessory information, help finding a dealer, or to register your product.

Model 51832T does not include a battery or a charger.

Models 51832, 51832T, and 51836 include Model 51810T Power Head and the Model 88716 String Trimmer Attachment.

The Model 51810T Power Head is compatible with a variety of Toro-approved attachments that, when combined, comply with specific standards; see the following table for more detail.

Combination	Power Head Model	Attachment Model	Standard
String Trimmer	51810T	88716	Conforms to UL STD 82 Certified to CSA STD C22.2 No. 147
Edger	51810T	88710	Conforms to UL STD 82 Certified to CSA STD C22.2 No. 147
Pole Saw	51810T	88714	Conforms to UL STD 82 Certified to CSA STD C22.2 No. 147
Cultivator	51810T	88715	Conforms to UL STD 82 Certified to CSA STD C22.2 No. 147
Hedge Trimmer	51810T	88713	Conforms to UL STD 62841-4-2 Certified to CSA STD C22.2 62841-4-2

Safety

WARNING—When using electric gardening appliances, always read and follow basic safety warnings and instructions to reduce the risk of fire, electric shock, and personal injury, including the following:

In addition to these instructions, always read and follow the safety warnings and instructions included with your specific attachment before operating the power head.

IMPORTANT SAFETY INSTRUCTIONS

I. Training

1. The operator of the appliance is responsible for any accidents or hazards occurring to others or their property.
2. Do not allow children to use or play with the appliance, battery pack, or the battery charger; local regulations may restrict the age of the operator.
3. Do not allow children or untrained people to operate or service this device. Allow only people who are responsible, trained, familiar with the instructions, and physically capable to operate or service the device.
4. Before using the appliance, battery pack, and battery charger, read all the instructions and cautionary markings on these products.
5. Become familiar with the controls and proper use of the appliance, battery pack, and battery charger.

II. Preparation

1. Keep bystanders and children away from the operating area.
2. Use only the battery pack specified by Toro. Using other accessories and attachments may increase the risk of injury and fire.
3. Plugging the battery charger into an outlet that is not 120 V can cause a fire or electric shock. Do not plug the battery charger into an outlet other than 120 V. For a different style of connection, use an attachment plug adapter of the proper configuration for the power outlet if needed.
4. Do not use a damaged or modified battery pack or battery charger, which may exhibit unpredictable behavior that results in fire, explosion, or risk of injury.
5. If the supply cord to the battery charger is damaged, contact an Authorized Service Dealer to replace it.

6. Do not use non-rechargeable batteries.
7. Charge the battery pack with only the battery charger specified by Toro. A charger suitable for 1 type of battery pack may create a risk of fire when used with another battery pack.
8. Charge the battery pack in a well-ventilated area only.
9. Do not expose a battery pack or battery charger to fire or to temperatures higher than 100°C (212°F).
10. Follow all charging instructions and do not charge the battery pack outside of the temperature range specified in the instructions. Otherwise, you may damage the battery pack and increase the risk of fire.
11. Do not operate the appliance without all guards and other safety protective devices in place and functioning properly on the appliance.
12. Dress properly—Wear appropriate clothing, including eye protection; long pants; substantial, slip-resistant footwear; rubber gloves; and hearing protection. Tie back long hair and do not wear loose clothing or loose jewelry that can get caught in moving parts. Wear a dust mask in dusty operating conditions.
10. Do not force the appliance—Allow the appliance to do the job better and safer at the rate for which it was designed.
11. Do not overreach—Keep proper footing and balance at all times, especially on slopes. Walk, never run with the appliance.
12. Stay alert—Watch what you are doing and use common sense when operating the appliance. Do not use the appliance while ill, tired, or under the influence of alcohol or drugs.
13. Ensure that the ventilation openings are kept clear of debris.
14. Under abusive conditions, the battery pack may eject liquid; avoid contact. If you accidentally come into contact with the liquid, flush with water. If the liquid contacts your eyes, seek medical help. Liquid ejected from the battery pack may cause irritation or burns.
15. CAUTION—A mistreated battery pack may present a risk of fire or chemical burn. Do not disassemble the battery pack. Do not heat the battery pack above 68°C (154°F) or incinerate it. Replace the battery pack with a genuine Toro battery pack only; using another type of battery pack may cause a fire or explosion. Keep battery packs out of the reach of children and in the original packaging until you are ready to use them.

III. Operation

1. Do not operate the power head without an attachment installed.
2. Avoid dangerous environments—Do not use the appliance in rain or in damp or wet locations.
3. Use the proper appliance for your application—Using the appliance for purposes other than its intended use could prove dangerous to you and bystanders.
4. Prevent unintentional starting—Ensure that the switch is in the OFF position before connecting to the battery pack and handling the appliance. Do not carry the appliance with your finger on the switch or energize the appliance with the switch in the ON position.
5. Operate the appliance only in daylight or good artificial light.
6. Remove the battery pack from the appliance before adjusting it or changing accessories.
7. Keep your hands and feet away from the cutting area and all moving parts.
8. Stop the appliance, remove the battery pack from the appliance, and wait for all movement to stop before adjusting, servicing, cleaning, or storing the appliance.
9. Remove the battery pack from the appliance whenever you leave it unattended.

IV. Maintenance and Storage

1. Maintain the appliance with care—Keep it clean and in good repair for best performance and to reduce the risk of injury. Follow the instructions for lubricating and changing accessories. Keep handles dry, clean, and free from oil and grease.
2. When the battery pack is not in use, keep it away from metal objects such as paper clips, coins, keys, nails, and screws that can make a connection from 1 terminal to another. Shorting the battery terminals may cause burns or a fire.
3. Keep your hands and feet away from moving parts.
4. Stop the appliance, remove the battery pack from the appliance, and wait for all movement to stop before adjusting, servicing, cleaning, or storing the appliance.
5. Check the appliance for damaged parts—If there are damaged guards or other parts, determine whether it will operate properly. Check for misaligned and binding moving parts, broken parts, mounting, and any other condition that may affect its operation. Unless indicated in the instructions, have an Authorized Service Dealer repair or replace a damaged guard or part.

6. Do not replace the existing non-metallic cutting means on the appliance with a metallic cutting means.
7. Do not attempt to service or repair the appliance, battery pack, or battery charger except as indicated in the instructions. Have an Authorized Service Dealer perform service using identical replacement parts to ensure that the product is safely maintained.
8. Store an idle appliance indoors in a place that is dry, secure, and out of the reach of children.
9. Do not dispose of the battery in a fire. The cell may explode. Check with local codes for possible special disposal instructions.

SAVE THESE INSTRUCTIONS

Safety and Instructional Decals



Safety decals and instructions are easily visible to the operator and are located near any area of potential danger. Replace any decal that is damaged or missing.

WARNING TO REDUCE THE RISK OF INJURY, USER MUST READ INSTRUCTION MANUAL. To reduce risk of electric shock, do not expose unit to water or operate unit on wet ground. Risk of eye injury. Use safety glasses or similar eye protection. Always use two hands when operating the unit. To reduce risk of injury to persons, remove battery pack when not in use. See instruction manual for compatible TORO 60v devices and attachments.

WARNING Cancer and Reproductive Harm - www.P65Warnings.ca.gov. For more information, please visit www.tcoCAProp65.com

AVERTISSEMENT POUR RÉDUIRE LES RISQUES DE BLESSURE, L'UTILISATEUR DOIT LIRE ET COMPRENDRE LE MODE D'EMPLOI. Pour réduire les risques d'électrocution, évitez tout contact de la machine avec l'eau et ne l'utilisez pas sur sol mouillé. Risque de blessure oculaire. Utilisez des lunettes de sécurité ou autre protection oculaire semblable. Toujours tenir la machine à deux mains pour l'utiliser. Pour réduire les risques de blessures corporelles, retirez la batterie quand vous ne l'utilisez pas. Voir le manuel d'instructions pour les appareils et accessoires TORO 60v compatibles.

AVERTISSEMENT Cancer et Troubles de l'appareil reproducteur - www.P65Warnings.ca.gov. Pour plus d'informations, veuillez visiter www.tcoCAProp65.com

decal145-3141

145-3141

Model 88620

THE TORO COMPANY
8111 Lyndale Avenue South
Bloomington, MN 55420-1196 USA **TORO**

RECHARGEABLE LITHIUM ION BATTERY PACK/
BATTERIE RECHARGEABLE AU LITHIUM-ION /
BATERIA DE ION-LITIO RECARGABLE
60 V MAX* DC 2.0 Ah, 108 Wh

See instruction manual for compatible TORO 60v devices and attachments. *60VDC MAXIMUM / 54VDC NOMINAL
Voir le manuel d'instructions pour les appareils et accessoires TORO 60v compatibles. *60 VDC MAXIMUM / 54 VDC NOMINALE
Consulte el manual de instrucciones para ver los dispositivos y accesorios TORO 60v compatibles. *60 VDC MÁXIMA / 54 VDC NOMINAL

PATENT: www.ttcopats.com
Country of Origin: China

Conforms to / Conforme à la norme / Cumples la norma UL STD 62133
Certified to / Certifié / Homologada según CSA STD C22.2 #62133

1

2 3 4

Model: **88620** • 151NR19/66

Serial Number: **3180000000** Date Code: **MM YY**

decal140-8475

140-8475

1. Read the *Operator's Manual*.
2. Call2Recycle® battery recycling program
3. Keep away from open fire or flames.
4. Do not expose to rain.

Model 88625

THE TORO COMPANY
8111 Lyndale Avenue South
Bloomington, MN 55420-1196 USA **TORO**

RECHARGEABLE LITHIUM ION BATTERY PACK/
BATTERIE RECHARGEABLE AU LITHIUM-ION /
BATERIA DE ION-LITIO RECARGABLE
60 V MAX* DC 2.5 Ah, 135 Wh

See instruction manual for compatible TORO 60v devices and attachments. *60VDC MAXIMUM / 54VDC NOMINAL
Voir le manuel d'instructions pour les appareils et accessoires TORO 60v compatibles. *60 VDC MAXIMUM / 54 VDC NOMINALE
Consulte el manual de instrucciones para ver los dispositivos y accesorios TORO 60v compatibles. *60 VDC MÁXIMA / 54 VDC NOMINAL

PATENT: www.ttcopats.com
Country of Origin: China

Conforms to / Conforme à la norme / Cumples la norma UL STD 62133
Certified to / Certifié / Homologada según CSA STD C22.2 #62133

1

2 3 4

Model: **88625** • 151NR19/66

Serial Number: **3180000000** Date Code: **MM YY**

decal137-9454

137-9454

1. Read the *Operator's Manual*.
2. Call2Recycle® battery recycling program
3. Keep away from open fire or flames.
4. Do not expose to rain.

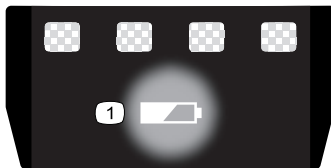

decal137-9461

137-9461

1. Battery charge status

LITHIUM-ION BATTERY CHARGER
CHARGEUR DE BATTERIE LITHIUM-ION
CARGADOR DE BATERIA DE ION-LITIO
Input: 120V AC ~ 60Hz 2A / Output: 60V DC 1A MAX
Backfeed Protection / Protection contre le retour d'énergie
Protección frente a retroalimentación

THE TORO COMPANY
8111 Lyndale Avenue South
Bloomington, MN 55420-1196 USA **TORO**

Country of Origin: China

PATENT: www.ttcopats.com Model: **88610**

Serial Number: **31800000** Date Code: **MM YY**

decal144-3098

144-3098

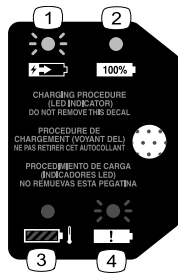

decal144-3094

144-3094

1. The battery pack is charging.
2. The battery pack is fully charged.
3. The battery pack is over or under the appropriate temperature range.
4. Battery pack charging fault



decal139-5210

139-5210

1. Warning—read the *Operator's Manual*; stay away from moving parts; keep all guards in place; wear eye protection; do not operate in wet conditions.

WARNING TO REDUCE THE RISK OF INJURY, USER MUST READ INSTRUCTION MANUAL. To reduce risk of electric shock, do not expose unit to water or operate unit on wet ground. Risk of eye injury. Use safety glasses or similar eye protection. To reduce the risk of injury to persons, do not operate without guards in place. Use safety glasses or similar eye protection. To reduce the risk of injury to persons, remove battery pack when not in use. For use with TORO FlexForce battery model: 88620. For use with TORO FlexForce charger model: 88610. See instruction manual for additional TORO FlexForce battery and charger options.

WARNING Cancer and Reproductive Harm - www.P65Warnings.ca.gov. For more information, please visit www.tcoCAProp65.com

AVERTISSEMENT POUR RÉDUIRE LES RISQUES DE BLESSURE, L'UTILISATEUR DOIT LIRE ET COMPRENDRE LE MODE D'EMPLOI. Pour réduire les risques d'électrocution, évitez tout contact de la machine avec l'eau et ne l'utilisez pas sur sol mouillé. Risque de blessure oculaire. Utilisez des lunettes de sécurité ou autre protection oculaire semblable. Pour réduire les risques de blessures corporelles, n'utilisez pas la machine si les dispositifs de protection ne sont pas en place. Pour réduire les risques de blessures corporelles, retirez la batterie quand vous ne l'utilisez pas. À utiliser avec la batterie TORO FlexForce modèle : 88620. À utiliser avec le chargeur TORO FlexForce modèle : 88610. Voir manuel d'utilisation pour des options supplémentaires.

AVERTISSEMENT Cancer et Troubles de l'appareil reproducteur - www.P65Warnings.ca.gov. Pour plus d'informations, veuillez visiter www.tcoCAProp65.com

decal144-3088

144-3088

CAUTION TO REDUCE THE RISK OF INJURY, USER MUST READ AND UNDERSTAND INSTRUCTION MANUAL. Charge only TORO 60V Li-Ion rechargeable battery. Other types of batteries may burst causing personal injury and damage. DANGER: Risk of electric shock. Do not expose to liquid, vapor, or rain. Do not interconnect output terminal. For indoor use only.

ATTENTION POUR RÉDUIRE LES RISQUES DE BLESSURE, L'UTILISATEUR DOIT LIRE ET COMPRENDRE LE MODE D'EMPLOI. Utiliser uniquement pour les batteries rechargeables type TORO 60V Li-Ion. D'autres types de batteries pourraient exploser et causer des blessures ou des dommages. DANGER: Risque de décharge électrique. Ne pas exposer à des liquides, à la vapeur ou à la pluie. Ne pas interconnecter la borne de sortie. Pour usage intérieur uniquement.

PRECAUCIÓN PARA REDUCIR EL RIESGO DE LESIONES, EL USUARIO DEBE LEER Y COMPRENDER EL MANUAL DE INSTRUCCIONES. Cargue únicamente baterías recargables de ion-litio TORO de 60 V. Otros tipos de batería pueden explotar y causar lesiones personales y daños materiales. PELIGRO: Riesgo de descarga eléctrica. No exponer a líquidos, vapor o lluvia. No interconectar un terminal de salida. Para uso en espacios interiores únicamente.

Conforms to / Conforme à la norme / Conforme à la norme UL STD 1012 / Conforme à la norme UL STD 1012 / Conforme à la norme UL STD 1012 / Other than Class 2 Battery Charger / Autre que Chargeur de batterie Classe 2 / Cargador de baterías distinto al de Clase 2

800797

decal144-3096

144-3096

LITHIUM-ION BATTERY CHARGER
CHARGEUR DE BATTERIE LITHIUM-ION
CARGADOR DE BATERÍA DE ION-LITIO
Input: 120V AC ~ 60Hz 2A / Output: 60V DC 2A MAX
Backfeed Protection / Protection contre le retour d'énergie / Protección frente a reenergización

CAUTION TO REDUCE THE RISK OF INJURY, USER MUST READ AND UNDERSTAND INSTRUCTION MANUAL. Charge only TORO 60V Li-Ion rechargeable battery. Other types of batteries may burst causing personal injury and damage. DANGER: Risk of electric shock. Do not expose to liquid, vapor, or rain. Do not interconnect output terminal. For indoor use only.

ATTENTION POUR RÉDUIRE LES RISQUES DE BLESSURE, L'UTILISATEUR DOIT LIRE ET COMPRENDRE LE MODE D'EMPLOI. Utiliser uniquement pour les batteries rechargeables type TORO 60V Li-Ion. D'autres types de batteries pourraient exploser et causer des blessures ou des dommages. DANGER: Risque de décharge électrique. Ne pas exposer à des liquides, à la vapeur ou à la pluie. Ne pas interconnecter la borne de sortie. Pour usage intérieur uniquement.

PRECAUCIÓN PARA REDUCIR EL RIESGO DE LESIONES, EL USUARIO DEBE LEER Y COMPRENDER EL MANUAL DE INSTRUCCIONES. Cargue únicamente baterías recargables de ion-litio TORO de 60 V. Otros tipos de batería pueden explotar y causar lesiones personales y daños materiales. PELIGRO: Riesgo de descarga eléctrica. No exponer a líquidos, vapor o lluvia. No interconectar un terminal de salida. Para uso en espacios interiores únicamente.

Model / Modèle / Modelo: 88602

THE TORO COMPANY
8111 Lyndale Avenue South
Bloomington, MN 55420-1196 USA

Country of Origin: China PATENT: www.tcopatents.com

Conforms to / Conforme à la norme / Conforme à la norme UL STD 1012 / Conforme à la norme UL STD 1012 / Conforme à la norme UL STD 1012 / Other than Class 2 Battery Charger / Autre que Chargeur de batterie Classe 2 / Cargador de baterías distinto al de Clase 2

800797

decal137-9462

137-9462

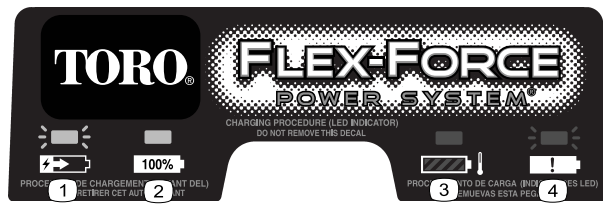

decal137-9463

137-9463

1. The battery pack is charging.
 2. The battery pack is fully charged.
 3. The battery pack is over or under the appropriate temperature range.
 4. Battery pack charging fault
-

Setup

1

Installing the Battery Guard Rod

Parts needed for this procedure:

1	Battery guard rod
---	-------------------

Procedure

1. Align the arms of the guard rod with the guide on the power head.
2. Lightly pull the arms of the guard rod so that they fit around the power head, and fit the rod ends into the mounting holes.

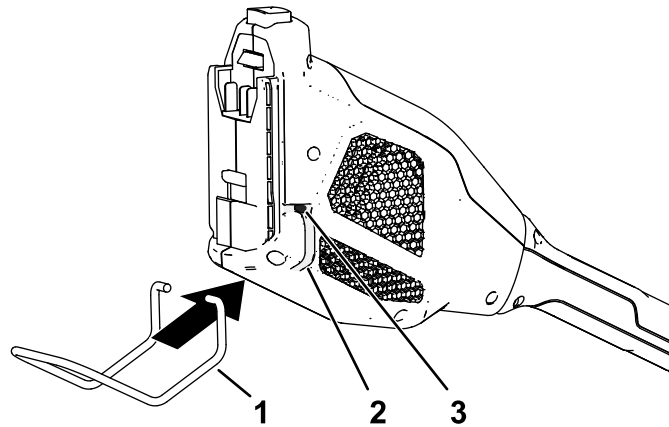

Figure 3

1. Battery guard rod
2. Rod guide

3. Mounting hole

g385364

2

Installing the Attachment

No Parts Required

Procedure

1. Install the square shaft of the string trimmer attachment into the square shaft of the power head (A of Figure 4).
2. Align the locking button on the lower shaft with the slotted hole on the upper shaft and slide the 2 shafts together (B and C of Figure 4).

Note: The locking button clicks into the slotted hole when the shafts are secured (C of Figure 4).

3. Using the screw-handle, tighten the screw on the shaft connector until it is secure (D of Figure 4).

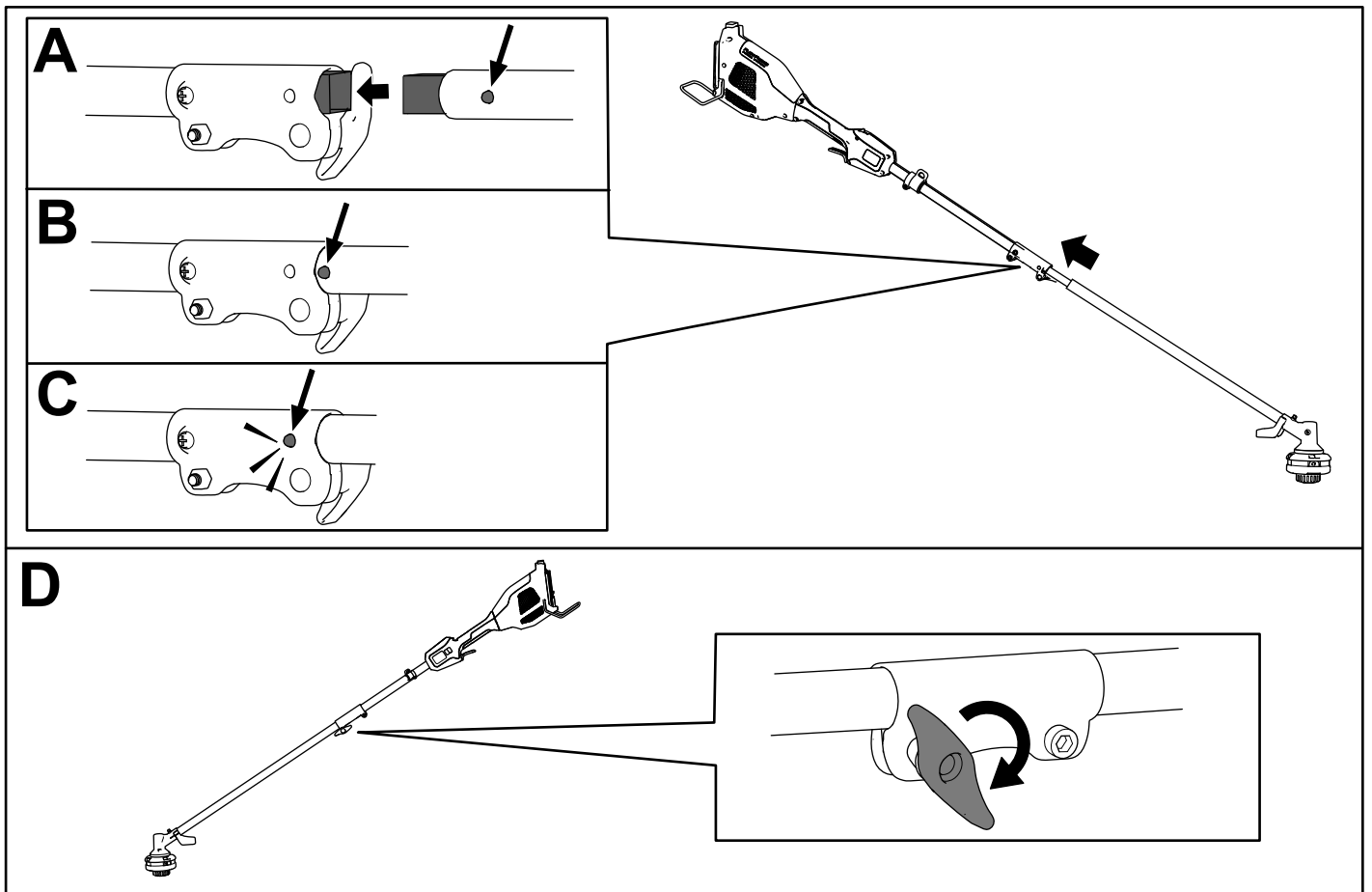

Figure 4

g357440

3

Installing the Auxiliary Handle

Parts needed for this procedure:

1	Auxiliary handle assembly
---	---------------------------

Procedure

1. Separate the auxiliary handle from the handle plate by removing the 4 socket head screws using the provided Allen wrench (A of [Figure 5](#)).
2. Line up the auxiliary handle with auxiliary handle plate on the trimmer handle (B of [Figure 5](#)).
3. Secure the auxiliary handle to the handle plate with the 4 socket head screws previously removed (C of [Figure 5](#)).

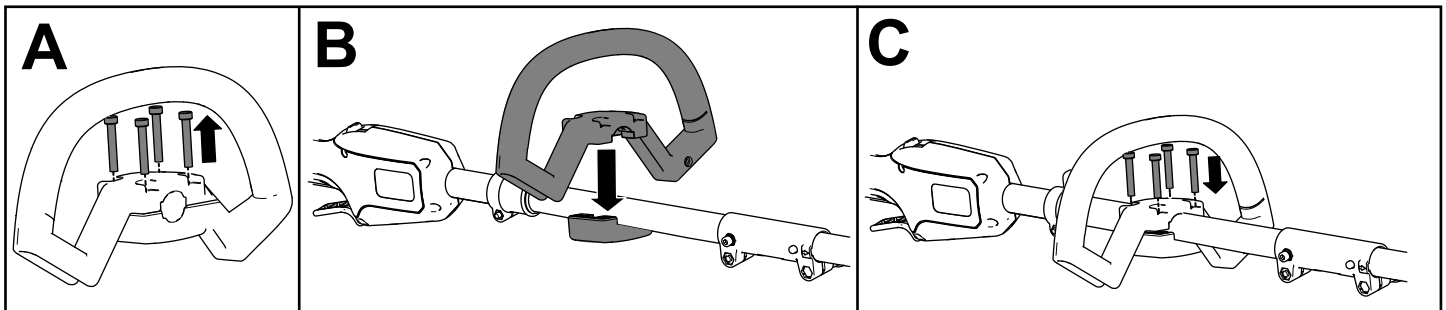

Figure 5

g357443

4

Installing the Guard

Parts needed for this procedure:

1	Guard
4	Washer
4	Bolt

Procedure

1. Align the trimmer guard beneath the guard mount as shown in [Figure 6](#).

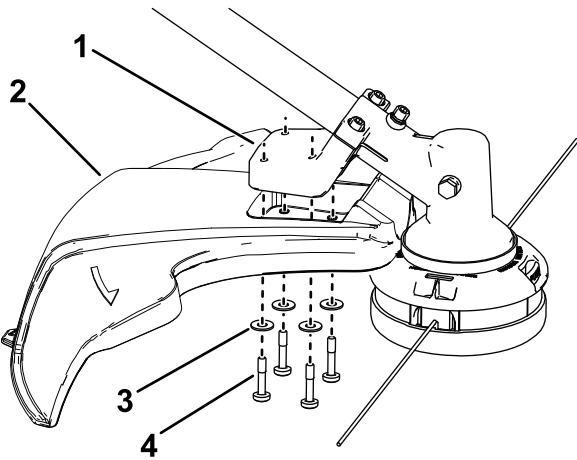

Figure 6

g333216

- 1. Guard mount
- 2. Trimmer guard
- 3. Washer
- 4. Bolt

2. Secure the guard to the trimmer using the 4 washers and 4 bolts as shown in [Figure 6](#).

Product Overview

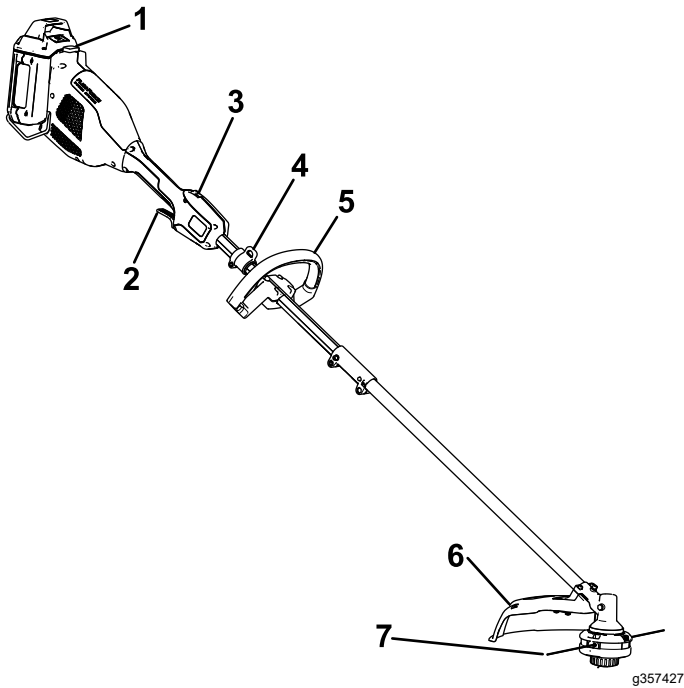

Figure 7

- 1. Battery latch
- 2. Run trigger
- 3. Lockout button
- 4. Harness/strap collar (harness/strap sold separately)
- 5. Auxiliary handle
- 6. Guard
- 7. String

Specifications

Model	51832/T and 51836
Charger Type	88610 (included with 51832), 88602 (included with 51836), or 88605
Battery Type	88620 (included with 51832), 88625 (included with 51836), 88640, 88650, 88660, or 88675

Appropriate Temperature Ranges

Charge/store the battery pack at	5°C (41°F) to 40°C (104°F)*
Use the battery pack at	-30°C (-22°F) to 49°C (120°F)
Use the trimmer at	0°C (32°F) to 49°C (120°F)
Store the trimmer at	0°C (32°F) to 49°C (120°F)*

*Charging time will increase if you do not charge the battery within this range.

Store the tool, battery pack, and battery charger in an enclosed clean, dry area.

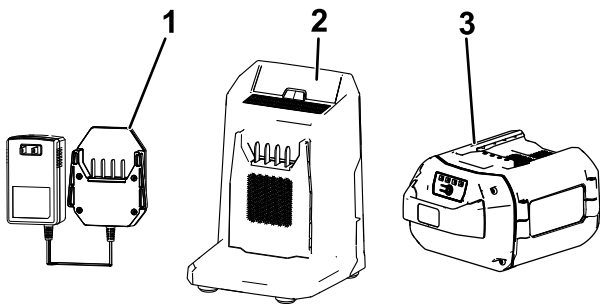

Figure 8

- 1. Battery charger Model 88610 (included with Model 51832)
- 2. Battery charger Model 88602 (included with Model 51836)
- 3. Battery pack

Operation

Starting the Trimmer

1. Make sure that the vents on the trimmer are clear of any dust and debris.
2. Align the cavity in the battery pack with the tongue on the handle housing (Figure 9).

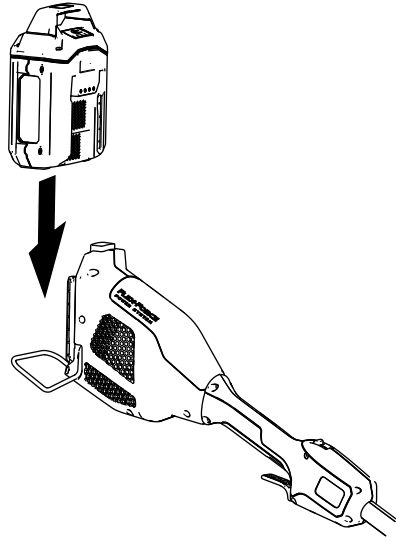

Figure 9

g357444

3. Push the battery pack into the handle until the battery locks into the latch.
4. To start the trimmer, press the lockout button, then squeeze the run trigger (Figure 10).

Note: Slide the variable-speed switch to change the speed of the trimmer.

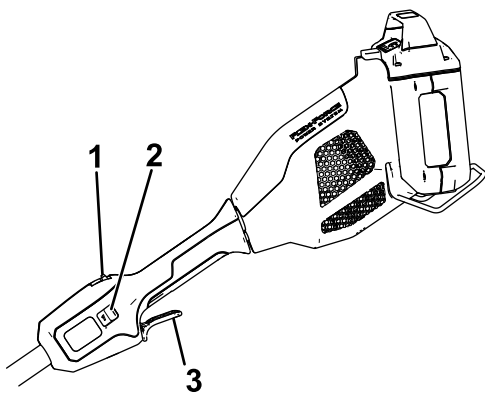

Figure 10

g357456

1. Lockout button
2. Variable-speed switch
3. Run trigger

Shutting Off the Trimmer

To shut off the trimmer, release the trigger.

Whenever you are not using the trimmer or are transporting the trimmer to or from the work area, remove the battery pack.

Removing the Battery Pack from the Trimmer

Press the battery latch on the machine to release the battery pack and slide the battery pack out of the machine (Figure 11).

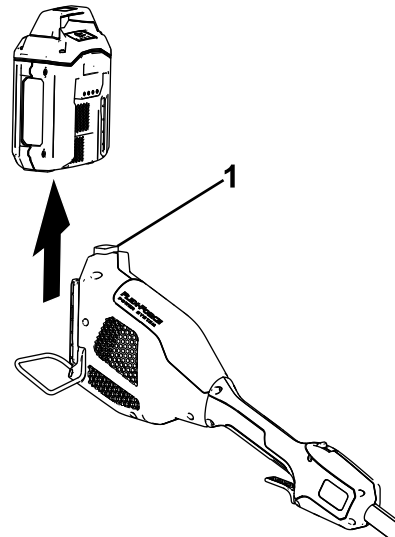

Figure 11

g357457

1. Battery latch

Charging the Battery Pack

Important: The battery pack is not fully charged when you purchase it. Before using the tool for the first time, place the battery pack in the charger and charge it until the LED display indicates the battery pack is fully charged. Read all safety precautions.

Important: Charge the battery pack only in temperatures that are within the appropriate range; refer to [Specifications \(page 13\)](#).

Note: At any time, press the battery-charge-indicator button on the battery pack to display the current charge (LED indicators).

1. Ensure that the vents on the battery and charger are clear of any dust and debris.
2. Line up the cavity in the battery pack ([Figure 12](#)) with the tongue on the charger.
3. Slide the battery pack into the charger until it is fully seated ([Figure 12](#)).
4. To remove the battery pack, slide the battery backward out of the charger.
5. Refer to the following table to interpret the LED indicator light on the battery charger.

Indicator light	Indicates
Off	No battery pack inserted
Green blinking	Battery pack is charging
Green	Battery pack is charged
Red	Battery pack and/or battery charger is over or under the appropriate temperature range
Red blinking	Battery pack charging fault*

*Refer to [Troubleshooting \(page 20\)](#) for more information.

Important: The battery can be left on the charger for short periods between uses.

If the battery will not be used for longer periods, remove the battery from the charger; refer to [Storage \(page 19\)](#).

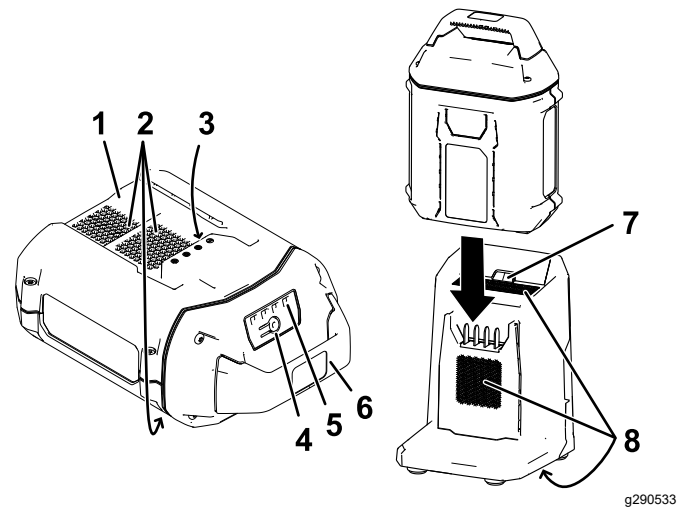

g290533

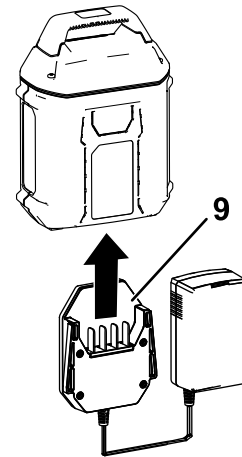

g331152

Figure 12

- | | |
|------------------------------------|--------------------------------|
| 1. Battery pack cavity | 6. Handle |
| 2. Battery pack venting areas | 7. Charger LED indicator light |
| 3. Battery pack terminals | 8. Charger venting areas |
| 4. Battery-charge-indicator button | 9. Adapter charger |
| 5. LED indicators (current charge) | |

Advancing the Line Using the Bump Feed

1. Run the trimmer at full throttle.
2. Tap the bump button on the ground to advance the line. The line advances each time the bump button is tapped. Do not hold the bump button on the ground.

Note: The line trimming cut-off blade on the grass deflector cuts the line to the correct length.

Note: If the line is worn too short, you may not be able to advance the line by tapping it on the ground. If so, release the trigger and refer to [Advancing the Line Manually \(page 16\)](#).

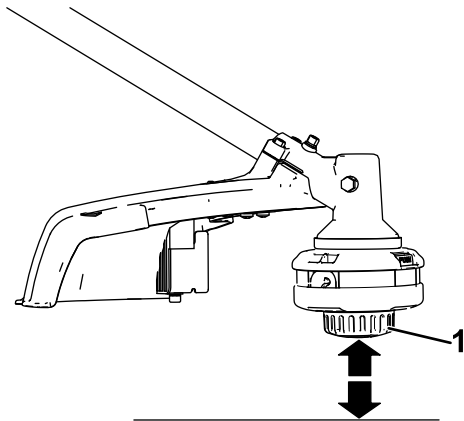

g331007

Figure 13

1. Bump button

Advancing the Line Manually

Remove the battery pack from the trimmer, then push the bump button at the base of the spool retainer while pulling on the trimmer line to manually advance the line.

Adjusting the Cutting Swath

The trimmer comes from the factory with a cutting swath of 33 cm (13 inches) as shown in A of Figure 14. Refer to the following instructions to adjust the swath to 38.1 cm (15 inches) as shown in D of Figure 14.

1. Remove the swath blade from the bottom of the guard by removing the 2 screws holding it in place (B of Figure 14) and rotate the swath blade 180°.
2. Once the swath blade is rotated, install it onto the guard using the 2 screws previously removed (C of Figure 14).

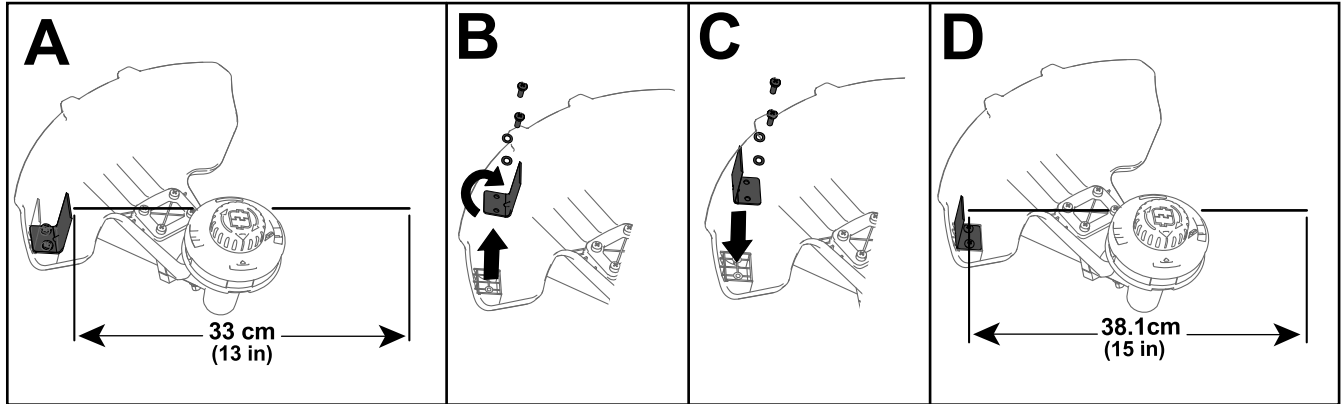

Figure 14

g339778

Operating Tips

- Keep the trimmer tilted toward the area being cut; this is the best cutting area.
- The string trimmer cuts when you move it from right to left. This prevents the trimmer from throwing debris at you.
- Use the tip of the string to do the cutting; do not force the string head into uncut grass.
- Wire and picket fences can cause the string to wear rapidly and even break. Stone and brick walls, curbs, and wood can also cause the string to wear rapidly.
- Avoid trees and shrubs. The string can easily damage tree bark, wood moldings, siding, and fence posts.

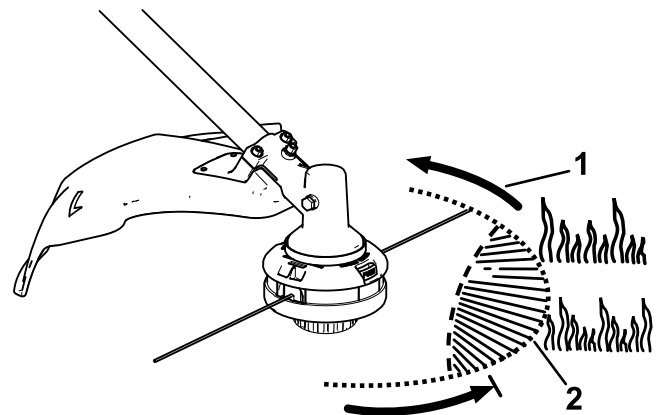

Figure 15

g330996

1. Direction of rotation
2. String path

Maintenance

After each use of the trimmer, complete the following:

1. Remove the battery from the trimmer.
2. Wipe the trimmer clean with a damp cloth. Do not hose the trimmer down or submerge it in water.

⚠ CAUTION

The line cutoff blade on the deflector is sharp and can cut you.

Do not use your hands to clean the deflector shield and blade.

3. Wipe or scrape clean the cutting head area any time there is an accumulation of debris.
4. Check and tighten all fasteners. If any part is damaged or lost, repair or replace it.
5. Brush debris away from air intake vents and exhaust on motor housing to prevent the motor from overheating.

Replacing the String

Important: Use only 2.4 mm (0.095 inch) twisted monofilament string (Part No. 88202)

1. Remove the battery pack and clean any debris from the trimmer head.
2. Remove any old string on the spool by repetitively pressing the bump button while pulling the line out equally from both sides of the trimmer.
3. Cut a piece of 2.4 mm (0.095 inch) string to approximately 3.9 m (13.0 ft).

Important: Do not use any other gauge or type of string, and do not exceed 3.9 m (13.0 ft) of string, as this could damage the trimmer.

4. Press and turn the knob on the string head until arrow on the knob aligns with arrow on the string head (Figure 16).
5. Insert 1 end of the line at an angle into the LINE IN eyelet and push the line through the string head track until it comes out through the eyelet on the other side. Pull the line through the string head until the line outside the string is evenly divided on each side.

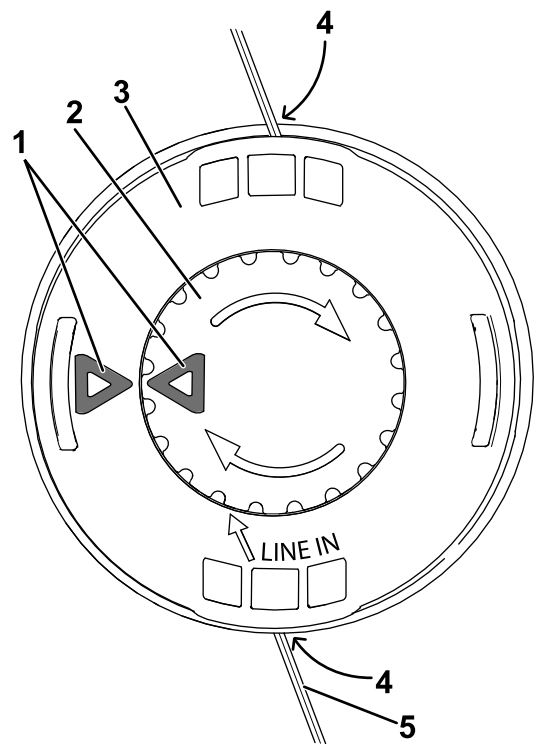

g330983

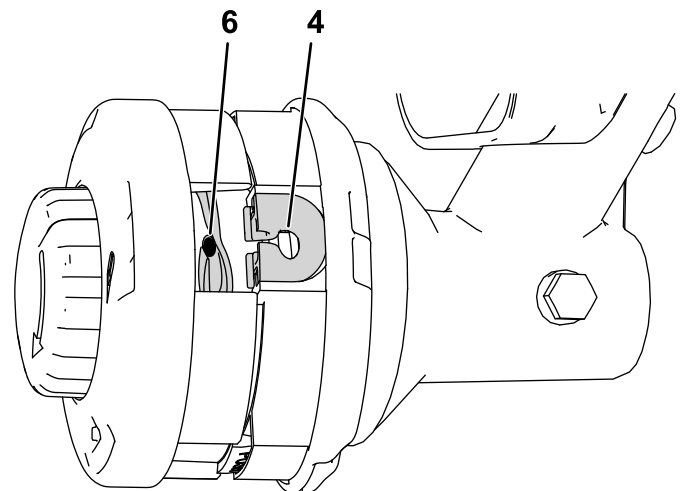

g330985

Figure 16

Disassembled view shown for clarity

- | | |
|----------------|-----------|
| 1. Arrows | 4. Eyelet |
| 2. Knob | 5. String |
| 3. String head | 6. Track |

Important: Do not disassemble the trimmer head.

6. Hold the string head in place with one hand. With your other hand, rotate the bump knob in the direction shown by the arrows (clockwise).
7. Wind the line, leaving about 130 mm (5 inches) extending beyond the eyelet on each side.

Storage

Important: Store the tool, battery pack, and charger only in temperatures that are within the appropriate range; refer to [Specifications \(page 13\)](#).

Important: If you are storing the battery pack for the off-season, remove the battery pack from the tool and charge the battery pack until 2 or 3 LED indicators turn green on the battery. Do not store a fully charged or fully depleted battery. When you are ready to use the tool again, charge the battery pack until the left indicator light turns green on the charger or all 4 LED indicators turn green on the battery.

- Disconnect the product from the power supply (i.e., remove the plug from the power supply or the battery pack) and check for damage after use.
- Do not store the tool with the battery pack installed.
- Clean all foreign material from the product.
- When not in use, store the tool, battery pack, and battery charger out of the reach of children.
- Keep the tool, battery pack, and battery charger away from corrosive agents, such as garden chemicals and de-icing salts.
- To reduce the risk of serious personal injury, do not store the battery pack outside or in vehicles.
- Store the tool, battery pack, and battery charger in an enclosed clean, dry area.

Preparing the Battery Pack for Recycling

Important: Upon removal, cover the terminals of the battery pack with heavy-duty adhesive tape. Do not attempt to destroy or disassemble the battery pack or remove any of its components.



Lithium-ion battery packs labeled with the Call2Recycle seal can be recycled at any participating retailer or battery recycling facility in the Call2Recycle program (US and Canada only). To locate a participating retailer or facility closest to you, please call 1-800-822-8837 or visit www.call2recycle.org. If you cannot locate a participating retailer or facility nearby, or if your rechargeable battery is not labeled with the Call2Recycle seal, please contact your local municipality for more information on how to responsibly recycle the battery. If you are located outside of the US and Canada, please contact your authorized Toro distributor.

Troubleshooting

Perform only the steps described in these instructions. All further inspection, maintenance, and repair work must be performed by an authorized service center or a similarly qualified specialist if you cannot solve the problem yourself.

Problem	Possible Cause	Corrective Action
The tool does not start.	<ol style="list-style-type: none"> 1. The battery is not fully installed in the tool. 2. The battery pack is not charged. 3. The battery pack is damaged. 4. There is another electrical problem with the tool. 	<ol style="list-style-type: none"> 1. Remove and then replace the battery into the tool, making sure that it is fully installed and latched. 2. Remove the battery pack from the tool and charge it. 3. Replace the battery pack. 4. Contact an Authorized Service Dealer.
The tool does not reach full power.	<ol style="list-style-type: none"> 1. The battery pack charge capacity is too low. 2. The air vents are blocked. 	<ol style="list-style-type: none"> 1. Remove the battery pack from the tool and fully charge the battery pack. 2. Clean the air vents.
The tool is producing excessive vibration or noise.	<ol style="list-style-type: none"> 1. There is debris on the drum area on the trimmer. 2. The spool is not properly wound. 	<ol style="list-style-type: none"> 1. Clean any debris off of the drum area. 2. Advance the line using the trigger switch and/or remove the line on the spool and wind the spool again.
The battery pack loses charge quickly.	<ol style="list-style-type: none"> 1. The battery pack is over or under the appropriate temperature range. 	<ol style="list-style-type: none"> 1. Move the battery pack to a place where it is dry and the temperature is between 5°C (41°F) and 40°C (104°F).
The battery charger is not working.	<ol style="list-style-type: none"> 1. The battery charger is over or under the appropriate temperature range. 2. The outlet that the battery charger is plugged into does not have power. 	<ol style="list-style-type: none"> 1. Unplug the battery charger and move it to a place where it is dry and the temperature is between 5°C (41°F) and 40°C (104°F). 2. Contact your licensed electrician to repair the outlet.
The LED indicator light on the battery charger is red.	<ol style="list-style-type: none"> 1. The battery charger and/or battery pack is over or under the appropriate temperature range. 	<ol style="list-style-type: none"> 1. Unplug the battery charger and move the battery charger and battery pack to a place where it is dry and the temperature is between 5°C (41°F) and 40°C (104°F).
The LED indicator light on the battery charger is blinking red.	<ol style="list-style-type: none"> 1. There is an error in the communication between the battery pack and the charger. 2. The battery pack is weak. 	<ol style="list-style-type: none"> 1. Remove the battery pack from the battery charger, unplug the battery charger from the outlet, and wait 10 seconds. Plug the battery charger into the outlet again and place the battery pack on the battery charger. If the LED indicator light on the battery charger is still blinking red, repeat this procedure again. If the LED indicator light on the battery charger is still blinking red after 2 attempts, properly dispose of the battery pack at a battery recycling facility. 2. Properly dispose of the battery pack at a battery recycling facility.
The tool does not run or run continuously.	<ol style="list-style-type: none"> 1. There is moisture on the leads of the battery pack. 2. The battery is not fully installed into the tool. 	<ol style="list-style-type: none"> 1. Allow the battery pack to dry or wipe it dry. 2. Remove and then replace the battery into the tool making sure that it is fully installed and latched.

Notes:

Notes:

California Proposition 65 Warning Information

What is this warning?

You may see a product for sale that has a warning label like the following:



WARNING: Cancer and Reproductive Harm—www.p65Warnings.ca.gov.

What is Prop 65?

Prop 65 applies to any company operating in California, selling products in California, or manufacturing products that may be sold in or brought into California. It mandates that the Governor of California maintain and publish a list of chemicals known to cause cancer, birth defects, and/or other reproductive harm. The list, which is updated annually, includes hundreds of chemicals found in many everyday items. The purpose of Prop 65 is to inform the public about exposure to these chemicals.

Prop 65 does not ban the sale of products containing these chemicals but instead requires warnings on any product, product packaging, or literature with the product. Moreover, a Prop 65 warning does not mean that a product is in violation of any product safety standards or requirements. In fact, the California government has clarified that a Prop 65 warning "is not the same as a regulatory decision that a product is 'safe' or 'unsafe.'" Many of these chemicals have been used in everyday products for years without documented harm. For more information, go to <https://oag.ca.gov/prop65/faqs-view-all>.

A Prop 65 warning means that a company has either (1) evaluated the exposure and has concluded that it exceeds the "no significant risk level"; or (2) has chosen to provide a warning based on its understanding about the presence of a listed chemical without attempting to evaluate the exposure.

Does this law apply everywhere?

Prop 65 warnings are required under California law only. These warnings are seen throughout California in a wide range of settings, including but not limited to restaurants, grocery stores, hotels, schools, and hospitals, and on a wide variety of products. Additionally, some online and mail order retailers provide Prop 65 warnings on their websites or in catalogs.

How do the California warnings compare to federal limits?

Prop 65 standards are often more stringent than federal and international standards. There are various substances that require a Prop 65 warning at levels that are far lower than federal action limits. For example, the Prop 65 standard for warnings for lead is 0.5 µg/day, which is well below the federal and international standards.

Why don't all similar products carry the warning?

- Products sold in California require Prop 65 labelling while similar products sold elsewhere do not.
- A company involved in a Prop 65 lawsuit reaching a settlement may be required to use Prop 65 warnings for its products, but other companies making similar products may have no such requirement.
- The enforcement of Prop 65 is inconsistent.
- Companies may elect not to provide warnings because they conclude that they are not required to do so under Prop 65; a lack of warnings for a product does not mean that the product is free of listed chemicals at similar levels.

Why does the manufacturer include this warning?

the manufacturer has chosen to provide consumers with as much information as possible so that they can make informed decisions about the products they buy and use. the manufacturer provides warnings in certain cases based on its knowledge of the presence of one or more listed chemicals without evaluating the level of exposure, as not all the listed chemicals provide exposure limit requirements. While the exposure from the manufacturer products may be negligible or well within the "no significant risk" range, out of an abundance of caution, the manufacturer has elected to provide the Prop 65 warnings. Moreover, if the manufacturer does not provide these warnings, it could be sued by the State of California or by private parties seeking to enforce Prop 65 and subject to substantial penalties.



Count on it.